



Cisco ATA 186 and Cisco ATA 188 Analog Telephone Adaptor Administrator's Guide for H.323 (version 3.0)

Corporate Headquarters

Cisco Systems, Inc.
170 West Tasman Drive
San Jose, CA 95134-1706
USA
<http://www.cisco.com>
Tel: 408 526-4000
800 553-NETS (6387)
Fax: 408 526-4100

Customer Order Number: OL-4804-01



THE SPECIFICATIONS AND INFORMATION REGARDING THE PRODUCTS IN THIS MANUAL ARE SUBJECT TO CHANGE WITHOUT NOTICE. ALL STATEMENTS, INFORMATION, AND RECOMMENDATIONS IN THIS MANUAL ARE BELIEVED TO BE ACCURATE BUT ARE PRESENTED WITHOUT WARRANTY OF ANY KIND, EXPRESS OR IMPLIED. USERS MUST TAKE FULL RESPONSIBILITY FOR THEIR APPLICATION OF ANY PRODUCTS.

THE SOFTWARE LICENSE AND LIMITED WARRANTY FOR THE ACCOMPANYING PRODUCT ARE SET FORTH IN THE INFORMATION PACKET THAT SHIPPED WITH THE PRODUCT AND ARE INCORPORATED HEREIN BY THIS REFERENCE. IF YOU ARE UNABLE TO LOCATE THE SOFTWARE LICENSE OR LIMITED WARRANTY, CONTACT YOUR CISCO REPRESENTATIVE FOR A COPY.

The following information is for FCC compliance of Class A devices: This equipment has been tested and found to comply with the limits for a Class A digital device, pursuant to part 15 of the FCC rules. These limits are designed to provide reasonable protection against harmful interference when the equipment is operated in a commercial environment. This equipment generates, uses, and can radiate radio-frequency energy and, if not installed and used in accordance with the instruction manual, may cause harmful interference to radio communications. Operation of this equipment in a residential area is likely to cause harmful interference, in which case users will be required to correct the interference at their own expense.

The following information is for FCC compliance of Class B devices: The equipment described in this manual generates and may radiate radio-frequency energy. If it is not installed in accordance with Cisco's installation instructions, it may cause interference with radio and television reception. This equipment has been tested and found to comply with the limits for a Class B digital device in accordance with the specifications in part 15 of the FCC rules. These specifications are designed to provide reasonable protection against such interference in a residential installation. However, there is no guarantee that interference will not occur in a particular installation.

Modifying the equipment without Cisco's written authorization may result in the equipment no longer complying with FCC requirements for Class A or Class B digital devices. In that event, your right to use the equipment may be limited by FCC regulations, and you may be required to correct any interference to radio or television communications at your own expense.

You can determine whether your equipment is causing interference by turning it off. If the interference stops, it was probably caused by the Cisco equipment or one of its peripheral devices. If the equipment causes interference to radio or television reception, try to correct the interference by using one or more of the following measures:

- Turn the television or radio antenna until the interference stops.
- Move the equipment to one side or the other of the television or radio.
- Move the equipment farther away from the television or radio.
- Plug the equipment into an outlet that is on a different circuit from the television or radio. (That is, make certain the equipment and the television or radio are on circuits controlled by different circuit breakers or fuses.)

Modifications to this product not authorized by Cisco Systems, Inc. could void the FCC approval and negate your authority to operate the product.

NOTWITHSTANDING ANY OTHER WARRANTY HEREIN, ALL DOCUMENT FILES AND SOFTWARE OF THESE SUPPLIERS ARE PROVIDED "AS IS" WITH ALL FAULTS. CISCO AND THE ABOVE-NAMED SUPPLIERS DISCLAIM ALL WARRANTIES, EXPRESSED OR IMPLIED, INCLUDING, WITHOUT LIMITATION, THOSE OF MERCHANTABILITY, FITNESS FOR A PARTICULAR PURPOSE AND NONINFRINGEMENT OR ARISING FROM A COURSE OF DEALING, USAGE, OR TRADE PRACTICE.

IN NO EVENT SHALL CISCO OR ITS SUPPLIERS BE LIABLE FOR ANY INDIRECT, SPECIAL, CONSEQUENTIAL, OR INCIDENTAL DAMAGES, INCLUDING, WITHOUT LIMITATION, LOST PROFITS OR LOSS OR DAMAGE TO DATA ARISING OUT OF THE USE OR INABILITY TO USE THIS MANUAL, EVEN IF CISCO OR ITS SUPPLIERS HAVE BEEN ADVISED OF THE POSSIBILITY OF SUCH DAMAGES.

CCIP, CCSP, the Cisco Arrow logo, the Cisco *Powered* Network mark, Cisco Unity, Follow Me Browsing, FormShare, and StackWise are trademarks of Cisco Systems, Inc.; Changing the Way We Work, Live, Play, and Learn, and iQuick Study are service marks of Cisco Systems, Inc.; and Aironet, ASIST, BPX, Catalyst, CCDA, CCDP, CCIE, CCNA, CCNP, Cisco, the Cisco Certified Internetwork Expert logo, Cisco IOS, the Cisco IOS logo, Cisco Press, Cisco Systems, Cisco Systems Capital, the Cisco Systems logo, Empowering the Internet Generation, Enterprise/Solver, EtherChannel, EtherSwitch, Fast Step, GigaStack, Internet Quotient, IOS, IP/TV, iQ Expertise, the iQ logo, iQ Net Readiness Scorecard, LightStream, MGX, MICA, the Networkers logo, Networking Academy, Network Registrar, *Packet*, PIX, Post-Routing, Pre-Routing, RateMUX, Registrar, ScriptShare, SlideCast, SMARTnet, StrataView Plus, Stratm, SwitchProbe, TeleRouter, The Fastest Way to Increase Your Internet Quotient, TransPath, and VCO are registered trademarks of Cisco Systems, Inc. and/or its affiliates in the U.S. and certain other countries.

All other trademarks mentioned in this document or Web site are the property of their respective owners. The use of the word partner does not imply a partnership relationship between Cisco and any other company. (0304R)

Cisco ATA 186 and Cisco ATA 188 Analog Telephone Adaptor Administrator's Guide for H.323 (version 3.0)

Copyright © 2003, Cisco Systems, Inc.

All rights reserved.



Preface xi

- Overview **xi**
- Audience **xi**
- Organization **xii**
- Conventions **xii**
- Related Documentation **xvi**
- Obtaining Documentation **xvi**
 - World Wide Web **xvi**
 - Documentation CD-ROM **xvii**
 - Ordering Documentation **xvii**
 - Documentation Feedback **xvii**
- Obtaining Technical Assistance **xvii**
 - Cisco.com **xviii**
 - Technical Assistance Center **xviii**
 - Cisco TAC Web Site **xviii**
 - Cisco TAC Escalation Center **xix**

CHAPTER 1

Cisco Analog Telephone Adaptor Overview 1-1

- H.323 Overview **1-2**
 - H.323 Terminals **1-3**
 - H.323 Gateways **1-3**
 - H.323 Gatekeepers **1-4**
 - H.323 MCUs **1-4**
 - H.323 Proxy Server **1-4**
- Hardware Overview **1-5**
- Software Features **1-7**
 - Voice Codecs Supported **1-7**
 - Additional Supported Signaling Protocols **1-7**
 - Other Supported Protocols **1-7**
 - Cisco ATA H.323 Services **1-8**
 - Fax Services **1-9**
 - Supplementary Services **1-9**
- Installation and Configuration Overview **1-9**

CHAPTER 2

Installing the Cisco ATA 2-1

- Safety Recommendations 2-1
- What the Cisco ATA Package Includes 2-2
- What You Need 2-2
- Installation Procedure 2-3
- Power-Down Procedure 2-5

CHAPTER 3

Configuring the Cisco ATA for H.323 3-1

- Default Boot Load Behavior 3-2
- Specifying a Preconfigured VLAN ID or Disabling VLAN IP Encapsulation 3-3
- Steps Needed to Configure the Cisco ATA 3-5
 - Basic Configuration Steps in a TFTP Server Environment 3-5
 - Basic Configuration Steps in a Non-TFTP Server Environment 3-7
- Configuring the Cisco ATA Using a TFTP Server 3-8
 - Setting Up the TFTP Server with Cisco ATA Software 3-8
 - Configurable Features and Related Parameters 3-8
 - Creating Unique and Common Cisco ATA Configuration Files 3-9
 - Using atapname.exe Tool to Obtain MAC Address 3-11
 - Using Encryption With the cfgfmt Tool 3-12
 - Examples of Upgrading to Stronger Encryption Key 3-15
 - atadefault.cfg Configuration File 3-17
 - Configuring the Cisco ATA to Obtain its Configuration File from the TFTP Server 3-18
 - Using a DHCP Server 3-18
 - Without Using a DHCP Server 3-20
- Voice Configuration Menu 3-20
 - Using the Voice Configuration Menu 3-21
 - Entering Alphanumeric Values 3-22
 - Resetting the Cisco ATA to Factory Default Values 3-23
- Cisco ATA Web Configuration Page 3-23
- Refreshing or Resetting the Cisco ATA 3-25
 - Procedure to Refresh the Cisco ATA 3-26
 - Procedure to Reset the Cisco ATA 3-26
- Obtaining Cisco ATA Configuration File After Failed Attempt 3-26
- Upgrading the H.323 Signaling Image 3-26

CHAPTER 4

Basic and Additional H.323 Services 4-1

- Important Basic H.323 Services 4-1
- Required Parameters 4-1

Setting Up User IDs for the Cisco ATA	4-3
Using the Cisco ATA with an H.323 Gatekeeper	4-3
Choosing Cisco ATA Registration Mode with an H.323 Gatekeeper	4-3
Setting Up Gatekeeper Time-To-Live Value	4-4
Setting Up an Alternate H.323 Gatekeeper	4-4
Establishing Authentication with Cisco H.323 Gatekeeper	4-5
Using the Cisco ATA Without an H.323 Gatekeeper	4-6
Using the Cisco ATA With an H.323 Gateway but Without an H.323 Gatekeeper	4-6
Using Multiple Cisco ATAs Without an H.323 Gatekeeper	4-6
Setting the Audio Codecs	4-7
Additional H.323 Services	4-7
Configurable Reboot of Cisco ATA	4-8
Configuring Audio Packet Settings	4-8
Configuring Billable Features	4-8
Configuring the Call Waiting Permanent Default Setting	4-9
Configuring the Cisco ATA Refresh Interval	4-9
Configuring Hook Flash Timing	4-9
Configuring the Mixing of Call Waiting Tone and Audio	4-9
Configuring Network Ringback Tone	4-10
Configuring Reverse Audio Cut-Through Behavior	4-10
Configuring Supplementary Service Behavior and Parameters	4-10
Debugging Diagnostics	4-10
Hardware Information Display	4-10
Network Timing	4-11
Polarity Settings	4-11
Progress Tones	4-11
Selecting DTMF and Hookflash Transmission Methods	4-11
Selecting H.323 Connection and H.245 Transmission Methods	4-12
Setting Dial Plans	4-12
Complete Reference Table of all Cisco ATA H.323 Services	4-12

CHAPTER 5**Parameters and Defaults 5-1**

Configuration Text File Template	5-2
User Interface (UI) Security Parameter	5-3
UIPassword	5-3
Parameters for Configuration Method and Encryption	5-4
UseTFTP	5-4
TftpURL	5-5
CfgInterval	5-6

EncryptKey	5-6
EncryptKeyEx	5-7
Network Configuration Parameters	5-8
DHCP	5-8
StaticIp	5-9
StaticRoute	5-9
StaticNetMask	5-10
NTPIP	5-10
AltNTPIP	5-11
DNS1IP	5-11
DNS2IP	5-12
VLANSetting	5-12
H.323 Parameters	5-13
GkOrProxy	5-13
GkId	5-14
GkTimeToLive	5-14
AltGk	5-14
AltGkTimeOut	5-15
UID0	5-16
PWD0	5-16
UID1	5-17
PWD1	5-18
LoginID0	5-18
LoginID1	5-19
UseLoginID	5-19
AuthMethod	5-20
Gateway	5-20
Audio Configuration Parameters	5-21
MediaPort	5-21
RxCodec	5-22
TxCodec	5-22
LBRCCodec	5-23
AudioMode	5-24
NumTxFrames	5-25
TOS	5-26
Operational Parameters	5-26
CallFeatures	5-27
PaidFeatures	5-28
CallCmd	5-29

FeatureTimer	5-30
FeatureTimer2	5-31
SigTimer	5-31
ConnectMode	5-32
OpFlags	5-34
TimeZone	5-36
Telephone Configuration Parameters	5-37
CallerIdMethod	5-38
Polarity	5-39
FXSInputLevel	5-40
FXSOutputLevel	5-40
Tone Configuration Parameters	5-41
Tone Parameter Syntax—Basic Format	5-41
Tone Parameter Syntax—Extended Formats	5-43
Extended Format A	5-43
Extended Format B	5-44
Recommended Values	5-48
Specific Tone Parameter Information	5-48
DialTone	5-48
BusyTone	5-49
ReorderTone	5-49
RingbackTone	5-50
CallWaitTone	5-50
AlertTone	5-51
RingOnOffTime	5-51
Dial Plan Parameters	5-52
DialPlan	5-52
Dial Plan Commands	5-53
Dial Plan Rules	5-54
Dial Plan Examples	5-58
DialPlanEx	5-60
IPDialPlan	5-60
Diagnostic Parameters	5-60
NPrintf	5-61
SyslogIP	5-61
SyslogCtrl	5-62
CFGID—Version Parameter for Cisco ATA Configuration File	5-63

CHAPTER 6

Call Commands 6-1

- Call Command Structure **6-1**
- Syntax **6-2**
 - Context-Identifiers **6-3**
 - Input Sequence Identifiers **6-4**
 - Action Identifiers **6-4**
- Call Command Example **6-5**
- Call Command Behavior **6-7**

CHAPTER 7

Configuring and Debugging Fax Services 7-1

- Using Fax Pass-through Mode **7-1**
 - Configuring the Cisco ATA for Fax Pass-through mode **7-2**
 - AudioMode **7-2**
 - ConnectMode **7-3**
 - Configuring Cisco IOS Gateways to Enable Fax Pass-through **7-3**
 - Enable Fax Pass-through Mode **7-4**
 - Disable Fax Relay Feature **7-5**
- Using FAX Mode **7-6**
 - Configuring the Cisco ATA for Fax Mode **7-6**
 - Configuring the Cisco ATA for Fax Mode on a Per-Call Basis **7-7**
 - Configuring the Cisco IOS Gateway for Fax Mode **7-7**
- Debugging the Cisco ATA 186/188 Fax Services **7-7**
 - Common Problems When Using IOS Gateways **7-7**
 - Using prserv for Diagnosing Fax Problems **7-9**
 - prserv Overview **7-9**
 - Analyzing prserv Output for Fax Sessions **7-10**
 - Using rtpcatch for Diagnosing Fax Problems **7-12**
 - rtpcatch Overview **7-12**
 - Example of rtpcatch **7-14**
 - Analyzing rtpcatch Output for Fax Sessions **7-16**
 - Using rtpcatch to Analyze Common Causes of Failure **7-18**
 - rtpcatch Limitations **7-20**

CHAPTER 8

Upgrading the Cisco ATA Signaling Image 8-1

- Upgrading the Signaling Image from a TFTP Server **8-1**
- Upgrading the Signaling Image Manually **8-2**
 - Preliminary Steps **8-3**
 - Running the Executable File **8-3**

Upgrade Requirements	8-3
Syntax	8-4
Upgrade Procedure and Verification	8-4
Confirming a Successful Signaling Image Upgrade	8-5
Using a Web Browser	8-5
Using the Voice Configuration Menu	8-6

CHAPTER 9**Troubleshooting 9-1**

General Troubleshooting Tips	9-1
Symptoms and Actions	9-2
Installation and Upgrade Issues	9-3
Debugging	9-4
Using System Diagnostics	9-5
Local Tone Playout Reporting	9-9
Obtaining Network Status Prior to Getting IP Connectivity	9-10
Obtaining Network Status After Getting IP Connectivity	9-11
DHCP Status HTML Page	9-12
Real-Time Transport Protocol (RTP) Statistics Reporting	9-12
Frequently Asked Questions	9-13
Contacting TAC	9-15

APPENDIX A**Using H.323 Supplementary Services A-1**

Changing Call Commands	A-1
Cancelling a Supplementary Service	A-1
Common Supplementary Services	A-1
Caller ID	A-2
Call-Waiting Caller ID	A-2
Making a Conference Call in the United States	A-2
Making a Conference Call in Sweden	A-3
Call Waiting in the United States	A-3
Call Waiting in Sweden	A-3
Calling Line Identification Presentation	A-3
About Calling Line Identification Restriction	A-4
Calling Line Identification Restriction in the United States	A-4
Calling Line Identification Restriction in Sweden	A-4

APPENDIX B

Voice Menu Codes B-1

APPENDIX C

Cisco ATA Specifications C-1

- Physical Specifications **C-1**
- Electrical Specifications **C-2**
- Environmental Specifications **C-2**
- Physical Interfaces **C-2**
- Ringing Characteristics **C-3**
- Software Specifications **C-3**

APPENDIX D

H.323 Signaling D-1

- Supported H.323 Messages **D-1**
- H.323 Signaling Scenarios **D-2**
 - H.323 Endpoint-to-Gatekeeper Registration **D-2**
 - H.323 Endpoint-to-Endpoint Call Setup with a Common Gatekeeper **D-5**
 - H.323 Call Setup from H.323 Network to Circuit Switched Network **D-14**

APPENDIX E

Recommended Cisco ATA Tone Parameter Values by Country E-1

GLOSSARY

INDEX



Preface

This preface includes the following sections:

- Overview, page xi
- Audience, page xi
- Organization, page xii
- Conventions, page xii
- Related Documentation, page xvi
- Obtaining Documentation, page xvi
- Obtaining Technical Assistance, page xvii

Overview

The *Cisco ATA 186 and Cisco ATA 188 Analog Telephone Adaptor Administrator's Guide (H.323)* provides the information you need to install, configure and manage the Cisco ATA 186 and Cisco ATA 188 on an H.323 network.



Note

The term *Cisco ATA* is used throughout this manual to refer to both the Cisco ATA 186 and the Cisco ATA 188, unless differences between the Cisco ATA 186 and Cisco ATA 188 are explicitly stated.

Audience

This guide is intended for service providers and network administrators who administer Voice over IP (VoIP) services using the Cisco ATA. Most of the tasks described in this guide are not intended for end users of the Cisco ATA. Many of these tasks impact the ability of the Cisco ATA to function on the network, and require an understanding of IP networking and telephony concepts.

Organization

Table 1 provides an overview of the organization of this guide.

Table 1 Cisco ATA 186 and Cisco ATA 188 Analog Telephone Adaptor Administrator's Guide (H.323) Organization

Chapter	Description
Chapter 1, "Cisco Analog Telephone Adaptor Overview"	Provides descriptions of hardware and software features of the Cisco ATA Analog Telephone Adaptor along with a brief overview of the H.323 protocol.
Chapter 2, "Installing the Cisco ATA"	Provides information about installing the Cisco ATA.
Chapter 3, "Configuring the Cisco ATA for H.323"	Provides information about configuring the Cisco ATA and the various methods for configuration.
Chapter 4, "Basic and Additional H.323 Services"	Provides information about H.323 services that the Cisco ATA supports.
Chapter 5, "Parameters and Defaults"	Provides information on all parameters and defaults that you can use to configure the Cisco ATA.
Chapter 6, "Call Commands"	Provides the Cisco ATA call commands for H.323.
Chapter 7, "Configuring and Debugging Fax Services"	Provides instructions for configuring both ports of the Cisco ATA to support fax transmission.
Chapter 8, "Upgrading the Cisco ATA Signaling Image"	Provides instructions for remotely upgrading Cisco ATA software.
Chapter 9, "Troubleshooting"	Provides basic testing and troubleshooting procedures for the Cisco ATA.
Appendix A, "Using H.323 Supplementary Services"	Provides end-user information about pre-call and mid-call services.
Appendix B, "Voice Menu Codes"	Provides a quick-reference list of the voice configuration menu options for the Cisco ATA.
Appendix C, "Cisco ATA Specifications"	Provides physical specifications for the Cisco ATA.
Appendix D, "H.323 Signaling"	Provides Cisco ATA call flows for H.323 scenarios.
Appendix E, "Recommended Cisco ATA Tone Parameter Values by Country"	Provides tone parameters for various countries.
Glossary	Provides definitions of commonly used terms.
Index	Provides reference information.

Conventions

This document uses the following conventions:

- Alternative keywords are grouped in braces and separated by vertical bars (for example, {x | y | z}).
- Arguments for which you supply values are in *italic* font.
- Commands and keywords are in **boldface** font.
- Elements in square brackets ([]) are optional.
- Information you must enter is in **boldface screen** font.

- Optional alternative keywords are grouped in brackets and separated by vertical bars (for example, [x | y | z]).
- Terminal sessions and information the system displays are in `screen` font.

**Note**

Means *reader take note*. Notes contain helpful suggestions or references to material not covered in the publication.

**Timesaver**

Means *the described action saves time*. You can save time by performing the action described in the paragraph.

**Tip**

Means *the following information will help you solve a problem*. The tips information might not be troubleshooting or even an action, but could be useful information, similar to a Timesaver.

**Caution**

Means *reader be careful*. In this situation, you might do something that could result in equipment damage or loss of data.

**Warning****IMPORTANT SAFETY INSTRUCTIONS**

This warning symbol means danger. You are in a situation that could cause bodily injury. Before you work on any equipment, be aware of the hazards involved with electrical circuitry and be familiar with standard practices for preventing accidents. Use the statement number provided at the end of each warning to locate its translation in the translated safety warnings that accompanied this device. Statement 1071

SAVE THESE INSTRUCTIONS**Waarschuwing****BELANGRIJKE VEILIGHEIDSINSTRUCTIES**

Dit waarschuwingssymbool betekent gevaar. U verkeert in een situatie die lichamelijk letsel kan veroorzaken. Voordat u aan enige apparatuur gaat werken, dient u zich bewust te zijn van de bij elektrische schakelingen betrokken risico's en dient u op de hoogte te zijn van de standaard praktijken om ongelukken te voorkomen. Gebruik het nummer van de verklaring onderaan de waarschuwing als u een vertaling van de waarschuwing die bij het apparaat wordt geleverd, wilt raadplegen.

BEWAAR DEZE INSTRUCTIES

Varoitus TÄRKEITÄ TURVALLISUUSOHJEITA

Tämä varoitusmerkki merkitsee vaaraa. Tilanne voi aiheuttaa ruumiillisia vammoja. Ennen kuin käsittelet laitteistoa, huomioi sähköpiirien käsittelemiseen liittyvät riskit ja tutustu onnettomuuksien yleisiin ehkäisytapoihin. Turvallisuusvaroitusten käännökset löytyvät laitteen mukana toimitettujen käännettyjen turvallisuusvaroitusten joukosta varoitusten lopussa näkyvien lausuntonumeroiden avulla.

SÄILYTÄ NÄMÄ OHJEET**Attention IMPORTANTES INFORMATIONS DE SÉCURITÉ**

Ce symbole d'avertissement indique un danger. Vous vous trouvez dans une situation pouvant entraîner des blessures ou des dommages corporels. Avant de travailler sur un équipement, soyez conscient des dangers liés aux circuits électriques et familiarisez-vous avec les procédures couramment utilisées pour éviter les accidents. Pour prendre connaissance des traductions des avertissements figurant dans les consignes de sécurité traduites qui accompagnent cet appareil, référez-vous au numéro de l'instruction situé à la fin de chaque avertissement.

CONSERVEZ CES INFORMATIONS**Warnung WICHTIGE SICHERHEITSHINWEISE**

Dieses Warnsymbol bedeutet Gefahr. Sie befinden sich in einer Situation, die zu Verletzungen führen kann. Machen Sie sich vor der Arbeit mit Geräten mit den Gefahren elektrischer Schaltungen und den üblichen Verfahren zur Vorbeugung vor Unfällen vertraut. Suchen Sie mit der am Ende jeder Warnung angegebenen Anweisungsnummer nach der jeweiligen Übersetzung in den übersetzten Sicherheitshinweisen, die zusammen mit diesem Gerät ausgeliefert wurden.

BEWAHREN SIE DIESE HINWEISE GUT AUF.**Avvertenza IMPORTANTI ISTRUZIONI SULLA SICUREZZA**

Questo simbolo di avvertenza indica un pericolo. La situazione potrebbe causare infortuni alle persone. Prima di intervenire su qualsiasi apparecchiatura, occorre essere al corrente dei pericoli relativi ai circuiti elettrici e conoscere le procedure standard per la prevenzione di incidenti. Utilizzare il numero di istruzione presente alla fine di ciascuna avvertenza per individuare le traduzioni delle avvertenze riportate in questo documento.

CONSERVARE QUESTE ISTRUZIONI**Advarsel VIKTIGE SIKKERHETSINSTRUKSJONER**

Dette advarselssymbolet betyr fare. Du er i en situasjon som kan føre til skade på person. Før du begynner å arbeide med noe av utstyret, må du være oppmerksom på farene forbundet med elektriske kretser, og kjenne til standardprosedyrer for å forhindre ulykker. Bruk nummeret i slutten av hver advarsel for å finne oversettelsen i de oversatte sikkerhetsadvarslene som fulgte med denne enheten.

TA VARE PÅ DISSE INSTRUKSJONENE

Aviso INSTRUÇÕES IMPORTANTES DE SEGURANÇA

Este símbolo de aviso significa perigo. Você está em uma situação que poderá ser causadora de lesões corporais. Antes de iniciar a utilização de qualquer equipamento, tenha conhecimento dos perigos envolvidos no manuseio de circuitos elétricos e familiarize-se com as práticas habituais de prevenção de acidentes. Utilize o número da instrução fornecido ao final de cada aviso para localizar sua tradução nos avisos de segurança traduzidos que acompanham este dispositivo.

GUARDE ESTAS INSTRUÇÕES**¡Advertencia! INSTRUCCIONES IMPORTANTES DE SEGURIDAD**

Este símbolo de aviso indica peligro. Existe riesgo para su integridad física. Antes de manipular cualquier equipo, considere los riesgos de la corriente eléctrica y familiarícese con los procedimientos estándar de prevención de accidentes. Al final de cada advertencia encontrará el número que le ayudará a encontrar el texto traducido en el apartado de traducciones que acompaña a este dispositivo.

GUARDE ESTAS INSTRUCCIONES**Varning! VIKTIGA SÄKERHETSANVISNINGAR**

Denna varningssignal signalerar fara. Du befinner dig i en situation som kan leda till personskada. Innan du utför arbete på någon utrustning måste du vara medveten om farorna med elkretsar och känna till vanliga förfaranden för att förebygga olyckor. Använd det nummer som finns i slutet av varje varning för att hitta dess översättning i de översatta säkerhetsvarningar som medföljer denna anordning.

SPARA DESSA ANVISNINGAR**Figyelem FONTOS BIZTONSÁGI ELOÍRÁSOK**

Ez a figyelmeztető jel veszélyre utal. Sérülésveszélyt rejtő helyzetben van. Mielőtt bármely berendezésen munkát végezte, legyen figyelemmel az elektromos áramkörök okozta kockázatokra, és ismerkedjen meg a szokásos balesetvédelmi eljárásokkal. A kiadványban szereplő figyelmeztetések fordítása a készülékhez mellékelt biztonsági figyelmeztetések között található; a fordítás az egyes figyelmeztetések végén látható szám alapján kereshető meg.

ORIZZE MEG EZEKET AZ UTASÍTÁSOKAT!**Предупреждение ВАЖНЫЕ ИНСТРУКЦИИ ПО СОБЛЮДЕНИЮ ТЕХНИКИ БЕЗОПАСНОСТИ**

Этот символ предупреждения обозначает опасность. То есть имеет место ситуация, в которой следует опасаться телесных повреждений. Перед эксплуатацией оборудования выясните, каким опасностям может подвергаться пользователь при использовании электрических цепей, и ознакомьтесь с правилами техники безопасности для предотвращения возможных несчастных случаев. Воспользуйтесь номером заявления, приведенным в конце каждого предупреждения, чтобы найти его переведенный вариант в переводе предупреждений по безопасности, прилагаемом к данному устройству.

СОХРАНИТЕ ЭТИ ИНСТРУКЦИИ

警告 重要的安全性说明

此警告符号代表危险。您正处于可能受到严重伤害的工作环境中。在您使用设备开始工作之前，必须充分意识到触电的危险，并熟练掌握防止事故发生的标准工作程序。请根据每项警告结尾提供的声明号码来找到此设备的安全性警告说明的翻译文本。

请保存这些安全性说明

警告 安全上の重要な注意事項

「危険」の意味です。人身事故を予防するための注意事項が記述されています。装置の取り扱い作業を行うときは、電気回路の危険性に注意し、一般的な事故防止策に留意してください。警告の各国語版は、各注意事項の番号を基に、装置に付属の「Translated Safety Warnings」を参照してください。

これらの注意事項を保管しておいてください。

Related Documentation

- RFC971 (*A Survey of Data Representation Standards*)
- RFC768 (*User Datagram Protocol*)
- RFC2198 (*RTP Payload for Redundant Audio Data*)
- RFC2833 (*RTP Payload for DTMF Digits, Telephony Phones and Telephony Signals*)
- *Read Me First - ATA Boot Load Information*
- *Cisco ATA 186 and Cisco 188 Analog Telephone Adaptor At a Glance*
- *Regulatory Compliance and Safety Information for the Cisco ATA 186 and Cisco 188*
- *Cisco ATA Release Notes*

Obtaining Documentation

These sections explain how to obtain documentation from Cisco Systems.

World Wide Web

You can access the most current Cisco documentation on the World Wide Web at this URL:

<http://www.cisco.com>

Translated documentation is available at this URL:

http://www.cisco.com/public/countries_languages.shtml

Documentation CD-ROM

Cisco documentation and additional literature are available in a Cisco Documentation CD-ROM package, which is shipped with your product. The Documentation CD-ROM is updated monthly and may be more current than printed documentation. The CD-ROM package is available as a single unit or through an annual subscription.

Ordering Documentation

You can order Cisco documentation in these ways:

- Registered Cisco.com users (Cisco direct customers) can order Cisco product documentation from the Networking Products MarketPlace:
http://www.cisco.com/cgi-bin/order/order_root.pl
- Registered Cisco.com users can order the Documentation CD-ROM through the online Subscription Store:
<http://www.cisco.com/go/subscription>
- Nonregistered Cisco.com users can order documentation through a local account representative by calling Cisco Systems Corporate Headquarters (California, U.S.A.) at 408 526-7208 or, elsewhere in North America, by calling 800 553-NETS (6387).

Documentation Feedback

You can submit comments electronically on Cisco.com. In the Cisco Documentation home page, click the **Fax** or **Email** option in the “Leave Feedback” section at the bottom of the page.

You can e-mail your comments to bug-doc@cisco.com.

You can submit your comments by mail by using the response card behind the front cover of your document or by writing to the following address:

Cisco Systems
Attn: Document Resource Connection
170 West Tasman Drive
San Jose, CA 95134-9883

We appreciate your comments.

Obtaining Technical Assistance

Cisco provides Cisco.com as a starting point for all technical assistance. Customers and partners can obtain online documentation, troubleshooting tips, and sample configurations from online tools by using the Cisco Technical Assistance Center (TAC) Web Site. Cisco.com registered users have complete access to the technical support resources on the Cisco TAC Web Site.

Cisco.com

Cisco.com is the foundation of a suite of interactive, networked services that provides immediate, open access to Cisco information, networking solutions, services, programs, and resources at any time, from anywhere in the world.

Cisco.com is a highly integrated Internet application and a powerful, easy-to-use tool that provides a broad range of features and services to help you with these tasks:

- Streamline business processes and improve productivity
- Resolve technical issues with online support
- Download and test software packages
- Order Cisco learning materials and merchandise
- Register for online skill assessment, training, and certification programs

If you want to obtain customized information and service, you can self-register on Cisco.com. To access Cisco.com, go to this URL:

<http://www.cisco.com>

Technical Assistance Center

The Cisco Technical Assistance Center (TAC) is available to all customers who need technical assistance with a Cisco product, technology, or solution. Two levels of support are available: the Cisco TAC Web Site and the Cisco TAC Escalation Center.

Cisco TAC inquiries are categorized according to the urgency of the issue:

- Priority level 4 (P4)—You need information or assistance concerning Cisco product capabilities, product installation, or basic product configuration.
- Priority level 3 (P3)—Your network performance is degraded. Network functionality is noticeably impaired, but most business operations continue.
- Priority level 2 (P2)—Your production network is severely degraded, affecting significant aspects of business operations. No workaround is available.
- Priority level 1 (P1)—Your production network is down, and a critical impact to business operations will occur if service is not restored quickly. No workaround is available.

The Cisco TAC resource that you choose is based on the priority of the problem and the conditions of service contracts, when applicable.

Cisco TAC Web Site

You can use the Cisco TAC Web Site to resolve P3 and P4 issues yourself, saving both cost and time. The site provides around-the-clock access to online tools, knowledge bases, and software. To access the Cisco TAC Web Site, go to this URL:

<http://www.cisco.com/tac>

All customers, partners, and resellers who have a valid Cisco service contract have complete access to the technical support resources on the Cisco TAC Web Site. The Cisco TAC Web Site requires a Cisco.com login ID and password. If you have a valid service contract but do not have a login ID or password, go to this URL to register:

<http://www.cisco.com/register/>

If you are a Cisco.com registered user, and you cannot resolve your technical issues by using the Cisco TAC Web Site, you can open a case online by using the TAC Case Open tool at this URL:

<http://www.cisco.com/tac/caseopen>

If you have Internet access, we recommend that you open P3 and P4 cases through the Cisco TAC Web Site.

Cisco TAC Escalation Center

The Cisco TAC Escalation Center addresses priority level 1 or priority level 2 issues. These classifications are assigned when severe network degradation significantly impacts business operations. When you contact the TAC Escalation Center with a P1 or P2 problem, a Cisco TAC engineer automatically opens a case.

To obtain a directory of toll-free Cisco TAC telephone numbers for your country, go to this URL:

<http://www.cisco.com/warp/public/687/Directory/DirTAC.shtml>

Before calling, please check with your network operations center to determine the level of Cisco support services to which your company is entitled: for example, SMARTnet, SMARTnet Onsite, or Network Supported Accounts (NSA). When you call the center, please have available your service agreement number and your product serial number.



Cisco Analog Telephone Adaptor Overview

This section describes the hardware and software features of the Cisco Analog Telephone Adaptor (Cisco ATA) and includes a brief overview of the H.323 protocol.

The Cisco ATA analog telephone adaptors are handset-to-Ethernet adaptors that allow regular analog telephones to operate on IP-based telephony networks. Cisco ATAs support two voice ports, each with an independent telephone number. The Cisco ATA 188 also has an RJ-45 10/100BASE-T data port.

This section covers the following topics:

- H.323 Overview, page 1-2
- Hardware Overview, page 1-5
- Software Features, page 1-7
- Installation and Configuration Overview, page 1-9

Figure 1-1 Cisco ATA Analog Telephone Adaptor

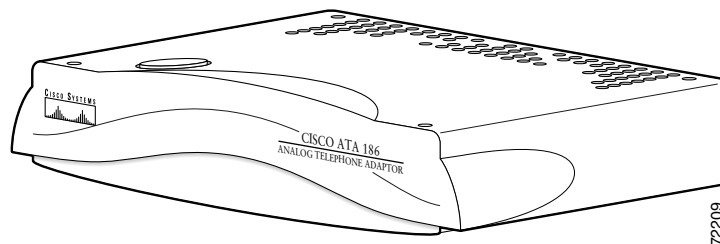

The Cisco ATA, which operates with Cisco voice-packet gateways, makes use of broadband pipes that are deployed through a digital subscriber line (DSL), fixed wireless-cable modem, and other Ethernet connections.



Note

The term *Cisco ATA* refers to both the Cisco ATA 186 and the Cisco ATA 188, unless otherwise stated.

Figure 1-2 Cisco ATA 186 as Endpoint in an H.323 Network

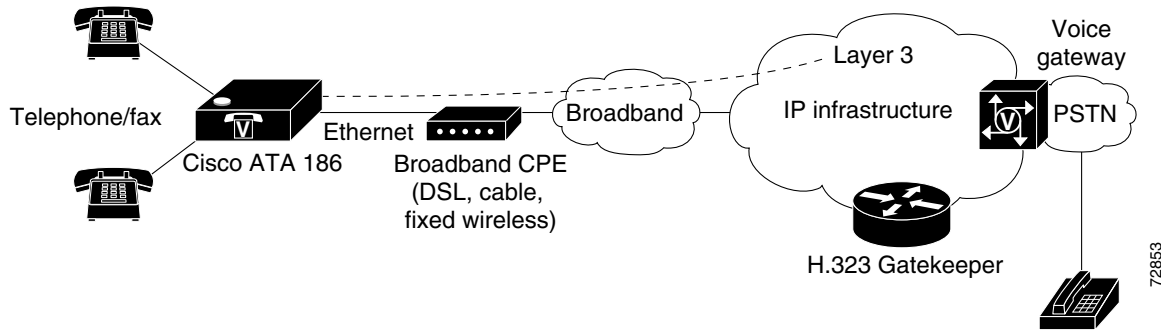

72853

Figure 1-3 Cisco ATA 188 as Endpoint in an H.323 Network

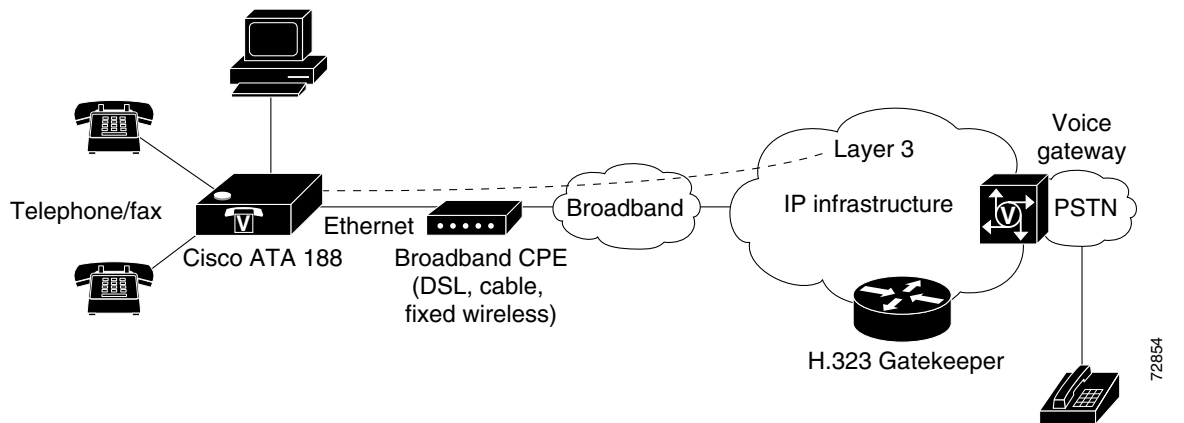

72854

H.323 Overview

H.323 is the International Telecommunication Union (ITU) standard for transmitting voice, video, and data across an IP network. Like other VoIP protocols, the H.323 standard is designed to address the functions of signaling and session management from within a packet telephony network. Signaling allows call information to be carried across network boundaries. Session management provides the ability to control the attributes of an end-to-end call. The H.323 standard includes support for call signaling and control, multimedia transport and control, and bandwidth control for both point-to-point and point-to-multipoint conferences.

The H.323 standard includes the following protocols:

- Call signaling using the H.225 protocol
- Media control using the H.245 protocol
- G.711, G.722, G.723, G.728, and G.729 audio codecs
- H.261 and H.263 video codecs
- Data sharing using the T.120 protocol
- Real-time transport protocol (RTP) and RTP Control Protocol (RTCP) for media transport

Components that the H.323 standard employs include a system of interconnected voice terminals, gateways, gatekeepers, multipoint control units (MCUs), and proxy servers. Voice terminals provide point-to-point and point-to-multipoint conference capability for audio, video, and data. Voice gateways interconnect the packetized IP network to the PSTN or ISDN network. Gatekeepers provide admission control and address translation services for H.323 voice terminals and gateways. MCUs enable two or more gateways to engage in point-to-point or point-to-multipoint audio or video conferences.

This section contains descriptions of the following H.323 components:

- H.323 Terminals, page 1-3
- H.323 Gateways, page 1-3
- H.323 Gatekeepers, page 1-4
- H.323 MCUs, page 1-4
- H.323 Proxy Server, page 1-4

Figure 1-4 H.323 Architecture

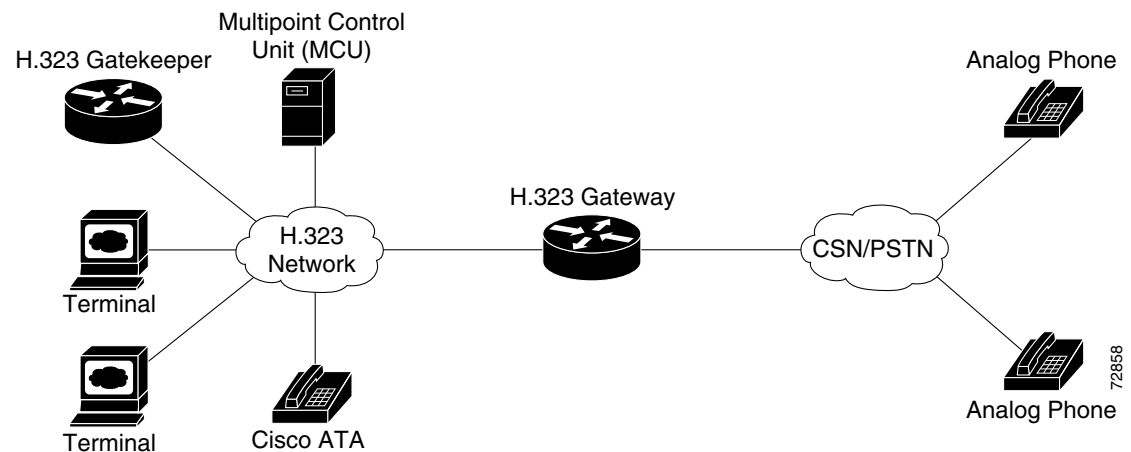

H.323 Terminals

Voice terminals in an H.323 network must feature system control units, media transmission capabilities, audio codecs, and network interfaces suitable for transmitting and receiving packetized data.

H.323 Gateways

H.323 gateways feature a mixture of characteristics of both standard Switched Circuit Network (SCN) access points and H.323 access points. Gateways perform the translation of audio, video, and data transmission formats as well as interacting with communications systems and various protocols. A primary responsibility of an H.323 gateway is the call setup and teardown necessary to complete a call to and from a packetized IP network and a standard switched network.



Note

Gateways are necessary in an H.323 system to connect calls over a packetized IP network to a switched circuit network such as the PSTN.

H.323 Gatekeepers

Gatekeepers are primarily responsible for pre-call and call-level control services for H.323 gateways. Gatekeepers are an optional component in an H.323 system. However, if present, gatekeepers *must* perform the following call setup and management services:

- Address translation for IP addresses originating from H.323 aliases (for example, address_pool@cisco.com, for example) or E.164 addresses (for example, standard telephone numbers)
- Admissions control for authorizing or rejecting access to H.323
- Bandwidth control for gateway bandwidth requirements
- Zone management for registered voice terminals, gateways and MCUs

When used in an H.323 system, gatekeepers can also (but are not required to) provide the following functionality:

- Call control signaling using the gatekeeper Routed Call Signaling model
- Call authorization to restrict access to certain voice terminals or gateways, or to restrict access based on time-of-day criteria
- Bandwidth management for the H.323 system that will enable the gateway to restrict access when requested bandwidth is unavailable
- Call management including maintaining a list of active calls to indicate available and unavailable voice terminals and gateways

H.323 MCUs

MCUs are endpoints in an H.323 network that support point-to-multipoint conferences and consist of a multipoint controller and at least one multipoint processor responsible for receiving voice, video, and data streams. These streams are distributed to access points participating in a point-to-multipoint conference.

H.323 Proxy Server

An H.323 proxy server is a proxy specifically designed for the H.323 protocol and examines packets between two communicating applications. Proxies can determine the destination of a call and perform call-connection steps, if necessary.

H.323 proxies perform the following key functions:

- Allow voice terminals that do not support Resource Reservation Protocol (RSVP) to connect to the proxy through remote access or local area networks with relatively reliable quality of service (QoS). Pairs of proxies can then be employed to develop tunnels across the IP network.
- Support routing of H.323 traffic that is separate from ordinary data traffic by using application-specific routing (ASR).
- Enable H.323 to be deployed in networks that use private address space.
- Ensure network security by configuring the proxy server to allow only H.323 traffic over the network.

Hardware Overview

The Cisco ATA 186 and Cisco ATA 188 are compact, easy-to-install devices. Figure 1-5 shows the rear panel of the Cisco ATA 186. Figure 1-6 shows the rear panel of the Cisco ATA 188.

Figure 1-5 Cisco ATA 186—Rear View

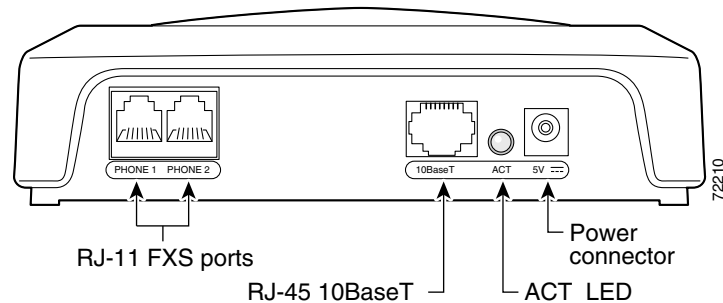
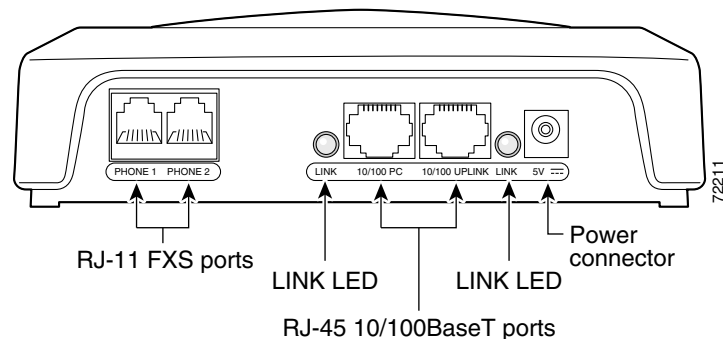

Figure 1-6 Cisco ATA 188—Rear View



The unit provides the following connectors and indicators:

- 5V power connector.
- Two RJ-11 FXS (Foreign Exchange Station) ports—The Cisco ATA supports two independent RJ-11 telephone ports that can connect to any standard analog telephone device. Each port supports either voice calls or fax sessions, and both ports can be used simultaneously.



Note

The Cisco ATA186-I1 and Cisco ATA188-I1 provide 600-ohm resistive impedance. The Cisco ATA 186-I2 and Cisco ATA188-I2 provide 270 ohm + 750 ohm // 150-nF complex impedance. The impedance option is requested when you place your order and should match your specific application. If you are not sure of the applicable configuration, check your country or regional telephone impedance requirements.

- Ethernet ports
 - The Cisco ATA 186 has one RJ-45 10BASE-T uplink Ethernet port to connect the Cisco ATA 186 to a 10/100BASE-T hub or another Ethernet device.
 - The Cisco ATA 188 has two Ethernet ports: an RJ-45 10/100BASE-T uplink port to connect the Cisco ATA 188 to a 10/100BASE-T hub or another Ethernet device and an RJ-45 10/100BASE-T data port to connect an Ethernet-capable device, such as a computer, to the network.

**Note**

The Cisco ATA 188 performs auto-negotiation for duplexity and speed and is capable of 10/100 Mbps, full-duplex operation. The Cisco ATA 186 is fixed at 10 Mbps, half-duplex operation.

- The Cisco ATA 188 RJ-45 LED shows network link and activity. The LED blinks twice when the Cisco ATA is first powered on, then turns off if there is no link or activity. The LED blinks to show network activity and is solid when there is a link.
- The Cisco ATA 186 RJ-45 LED is solid when the Cisco ATA is powered on and blinks to show network activity.
- Function button—The function button is located on the top panel of the unit (see Figure 1-7).

Figure 1-7 Function Button

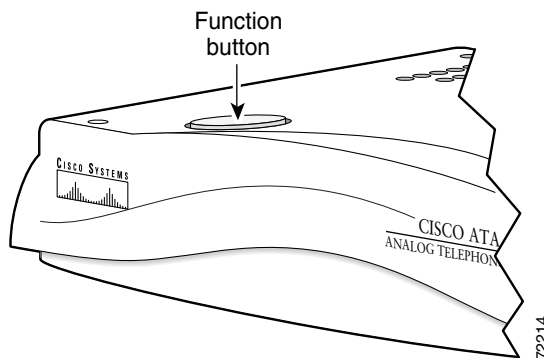

The function button lights when you pick up the handset of a telephone attached to the Cisco ATA. The button blinks quickly when the Cisco ATA is upgrading its configuration.

**Note**

If the function button blinks slowly, the Cisco ATA cannot find the DHCP server. Check your Ethernet connections and make sure the DHCP server is available.

Pressing the function button allows you to access to the voice configuration menu. For additional information about the voice configuration menu, see the “Voice Configuration Menu” section on page 3-20.

**Caution**

Never press the function button during an upgrade process. Doing so may interfere with the process.

Software Features

The Cisco ATA supports the following protocols, services and methods:

- Voice Codecs Supported, page 1-7
- Additional Supported Signaling Protocols, page 1-7
- Other Supported Protocols, page 1-7
- Cisco ATA H.323 Services, page 1-8
- Fax Services, page 1-9
- Supplementary Services, page 1-9

Voice Codecs Supported

The Cisco ATA supports the following voice codecs (check your other network devices for the codecs they support):

- G.711 μ -law
- G.711A-law
- G.723.1
- G.729
- G.729A
- G.729B
- G.729AB

Additional Supported Signaling Protocols

In addition to H.323, the Cisco ATA supports the following signaling protocols:

- Session Initiation Protocol (SIP)
- Skinny Client Control Protocol (SCCP)
- Media Gateway Control Protocol (MGCP)

If you wish to perform a cross-protocol upgrade from H.323 to another signaling image, see the “Upgrading the Signaling Image from a TFTP Server” section on page 8-1.

Other Supported Protocols

Other protocols that the Cisco ATA supports include the following:

- 802.1Q VLAN tagging
- Cisco Discovery Protocol (CDP)
- Domain Name System (DNS)
- Dynamic Host Configuration Protocol (DHCP)
- Internet Control Message Protocol (ICMP)

- Internet Protocol (IP)
- Real-Time Transport Protocol (RTP)
- Transmission Control Protocol (TCP)
- Trivial File Transfer Protocol (TFTP)
- User Datagram Protocol (UDP)

Cisco ATA H.323 Services

For a list of required H.323 parameters as well as descriptions of all supported Cisco ATA H.323 services and cross references to the parameters for configuring these services, see Chapter 4, “Basic and Additional H.323 Services.”

These services include the following features:

- Supports direct IP dialing to and from a Cisco ATA without using an H.323 gatekeeper
- Supports direct IP dialing in addition to proxy-routed calls to and from either phone
- Uses the same configurable MediaPort to transmit and receive RTP audio
- Uses UDP only for H.323 RAS message transmission
- Uses a TCP connection for H.225/Q.931 signaling (such as call setup, call proceeding, alerting, and call connect)
- IP address assignment—DHCP-provided or statically configured
- Cisco ATA configuration by means of a TFTP server, web browser, or voice configuration menu.
- VLAN configuration
- Cisco Discovery Protocol (CDP)
- Low-bit-rate codec selection
- User authentication
- Configurable tones (dial tone, busy tone, alert tone, reorder tone, call waiting tone)
- Dial plans
- User-configurable, call-waiting, permanent default setting
- Silence suppression and comfort noise generation for G.711, G.723.1 (G.723.1 Annex A), and G.729 (G.729 Annex B)
- Caller ID format
- Ring cadence format
- Hook-flash detection timing configuration
- Type of Service (ToS) configuration for audio and signaling ethernet packets
- Hotline and warmline support (private line automatic ringdown)
- Debugging and diagnostic tools

Fax Services

The Cisco ATA supports two modes of fax services, in which fax signals are transmitted using the G.711 codec:

- Fax pass-through mode—Receiver-side Called Station Identification (CED) tone detection with automatic G.711A-law or G.711 μ -law switching.
- Fax mode—The Cisco ATA is configured as a G.711-only device.

How you set Cisco ATA fax parameters depends on what network gateways are being used. You may need to modify the default fax parameter values (see Chapter 7, “Configuring and Debugging Fax Services”).



Note

Success of fax transmission depends on network conditions and fax modem response to these conditions. The network must have reasonably low network jitter, network delay, and packet loss rate.

Supplementary Services

H.323 supplementary services are services that you can use to enhance your telephone service. For information on how to enable and subscribe to these services, see the “CallFeatures” section on page 5-27 and the “PaidFeatures” section on page 5-28.

For information on how to use these services, see Appendix A, “Using H.323 Supplementary Services.”

The following list contains the H.323 supplementary services that the Cisco ATA supports:

- Caller ID
- Calling line ID presentation/rejection (CLIP/CLIR)
- Call waiting
- Call waiting Caller ID
- Three-way calling

Installation and Configuration Overview

Table 1-1 provides the basic steps required to install and configure the Cisco ATA to make it operational.

Table 1-1 Overview of the Steps Required to Install and Configure the Cisco ATA and Make it Operational

Action	Reference
1. Plan the network and Cisco ATA configuration.	
2. Install the Ethernet connection.	
3. Install and configure the other network devices.	
4. Install the Cisco ATA but do not power up the Cisco ATA yet.	What the Cisco ATA Package Includes, page 2-2
5. Download the desired Cisco ATA release software zip file from the Cisco web site, then configure the Cisco ATA.	Chapter 3, “Configuring the Cisco ATA for H.323”

Action	Reference
6. Power up the Cisco ATA.	
7. Periodically, you can upgrade the Cisco ATA to a new signaling image by using the TFTP server-upgrade method or the manual-upgrade method.	Chapter 8, “Upgrading the Cisco ATA Signaling Image”



Installing the Cisco ATA

This section provides instructions for installing the Cisco ATA 186 and Cisco ATA 188. Before you perform the installation, be sure you have met the following prerequisites:

- Planned the network and Cisco ATA configuration.
- Installed the Ethernet connection.
- Installed and configured the other network devices.

This section contains the following topics:

- Safety Recommendations, page 2-1
- What the Cisco ATA Package Includes, page 2-2
- What You Need, page 2-2
- Installation Procedure, page 2-3
- Power-Down Procedure, page 2-5



Note

The term *Cisco ATA* is used throughout this manual to refer to both the Cisco ATA 186 and the Cisco ATA 188, unless differences between the Cisco ATA 186 and Cisco ATA 188 are explicitly stated.

Safety Recommendations

To ensure general safety, follow these guidelines:

- Do not get this product wet or pour liquids into this device.
- Do not open or disassemble this product.
- Do not perform any action that creates a potential hazard to people or makes the equipment unsafe.
- Use only the power supply that comes with the Cisco ATA.



Warning

Ultimate disposal of this product should be handled according to all national laws and regulations.



Warning

Read the installation instructions before you connect the system to its power source.

**Warning**

The plug-socket combination must be accessible at all times because it serves as the main disconnecting device.

**Warning**

Do not work on the system or connect or disconnect cables during periods of lightning activity.

**Warning**

This equipment contains a ring signal generator (ringer), which is a source of hazardous voltage. Do not touch the RJ-11 (phone) port wires (conductors), the conductors of a cable connected to the RJ-11 port, or the associated circuit-board when the ringer is active. The ringer is activated by an incoming call.

For translated warnings, see the *Regulatory Compliance and Safety Information for the Cisco ATA 186 and Cisco ATA 188* manual.

What the Cisco ATA Package Includes

The Cisco ATA package contains the following items:

- Cisco ATA 186 or Cisco ATA 188 Analog Telephone Adaptor
- *Read Me First - ATA Boot Load Information*
- *Cisco ATA 186 and Cisco ATA 188 Analog Telephone Adaptor at a Glance*
- Regulatory Compliance and Safety Information for the Cisco ATA 186 and Cisco ATA 188
- 5V power adaptor
- Power cord

**Note**

The Cisco ATA is intended for use only with the 5V DC power adaptor that comes with the unit.

What You Need

You also need the following items:

- Category-3 10BASE-T or 100BASE-T or better Ethernet cable. One cable is needed for each Ethernet connection.

A Category-3 Ethernet cable supports 10BASE-T for up to 100 meters without quality degradation, and a Category-3 Ethernet cable supports 100BASE-T for up to 10 meters without quality degradation.

For uplink connections, use a crossover Ethernet cable to connect the Cisco ATA to another Ethernet device (such as a router or PC) without using a hub. Otherwise, use straight-through Ethernet cables for both uplink and data port connections.

- Access to an IP network
- One or two analog Touch-Tone telephones or fax machines, or one of each

Installation Procedure

After the equipment is in place, see Figure 2-1 (for Cisco ATA 186) or Figure 2-2 (for Cisco ATA 188) and follow the next procedure to install the Cisco ATA.

Figure 2-1 Cisco ATA 186 Rear Panel Connections

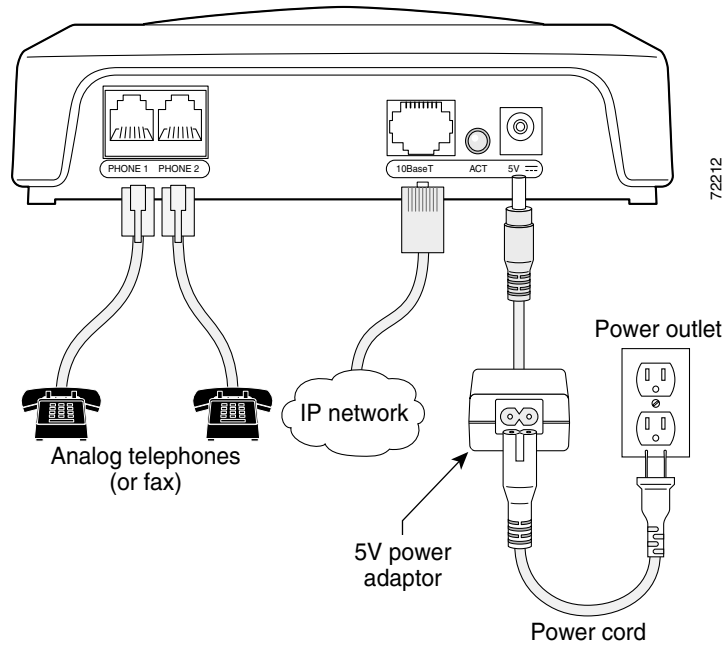
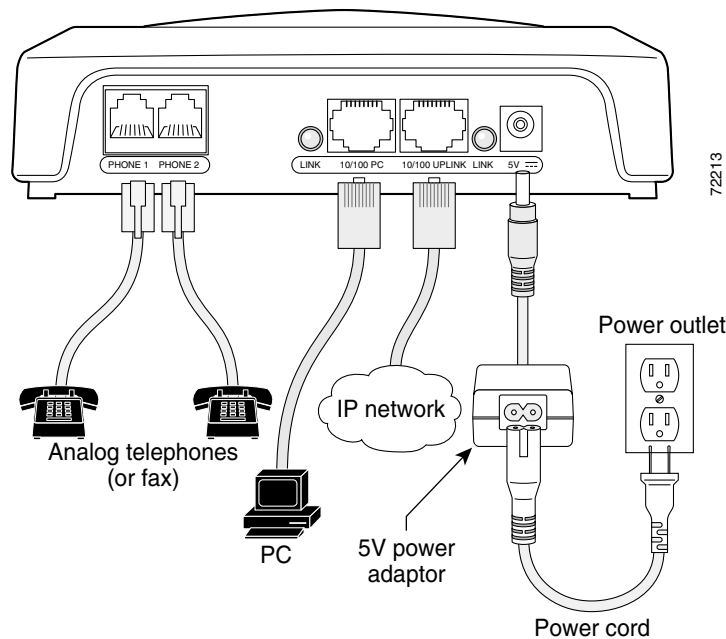

Figure 2-2 Cisco ATA 188 Rear Panel Connections



Procedure

Step 1 Place the Cisco ATA near an electrical power outlet.

Step 2 Connect one end of a telephone line cord to the **Phone 1** input on the rear panel of the Cisco ATA. Connect the other end to an analog telephone set.

If you are connecting a telephone set that was previously connected to an active telephone line, unplug the telephone line cord from the wall jack and plug it into the **Phone 1** input.



Warning

To reduce the risk of fire, use only No. 26 AWG or larger telecommunication line cord.



Caution

Do not connect the **Phone** input ports to a telephone wall jack. To avoid damaging the Cisco ATA or telephone wiring in the building, do not connect the Cisco ATA to the telecommunications network. Connect the **Phone** port to a telephone only, never to a telephone wall jack.



Note

The telephone must be switched to tone setting (not pulse) for the Cisco ATA to operate properly.

Step 3 (Optional) Connect the telephone line cord of a second telephone to the **Phone 2** input port.

If you are connecting only one telephone to the Cisco ATA, you must use the **Phone 1** input port.

Step 4 Connect an Ethernet cable to the uplink RJ-45 connector on the Cisco ATA. For the Cisco ATA 186, this is the 10BASE-T connector; for the Cisco ATA 188, this is the 10/100UPLINK connector.

Use a crossover Ethernet cable to connect the Cisco ATA to another Ethernet device (such as a router or PC) without using a hub. Otherwise, use a straight-through Ethernet cable.

Step 5 (Cisco ATA 188 only—optional) Connect a straight-through Ethernet cable from your PC to the 10/100 PC RJ-45 connector on the Cisco ATA.

Step 6 Connect the socket end of the power cord to the Cisco-supplied 5V DC power adaptor.

Step 7 Insert the power adaptor cable into the power connector on the Cisco ATA.



Caution

Use only the Cisco-supplied power adaptor.



Warning

This product relies on the building's installation for short-circuit (overcurrent) protection. Ensure that a fuse or circuit breaker no larger than 120 VAC, 15A U.S. (240VAC, 10A international) is used on the phase conductors (all current-carrying conductors).

Step 8 Connect the plug end of the 5V DC power adaptor cord into an electrical power outlet.

When the Cisco ATA is properly connected and powered up, the green activity LED flashes to indicate network activity. This LED is labeled **ACT** on the rear panel of the Cisco ATA 186 and is labeled **LINK** on the rear panel of the Cisco ATA 188.



Caution

Do not cover or block the air vents on either the top or the bottom surface of the Cisco ATA. Overheating can cause permanent damage to the unit.

For more information about LEDs and the function button, see the “Hardware Overview” section on page 1-5.

Power-Down Procedure

**Caution**

If you need to power down Cisco ATA 186 or Cisco 188 at any time, use the following power-down procedure to prevent damage to the unit.

Procedure

-
- Step 1** Unplug the RJ45 Ethernet cable
- Step 2** Wait for 20 seconds.
- Step 3** Unplug the power cable.
-

**Warning**

This equipment contains a ring signal generator (ringer), which is a source of hazardous voltage. Do not touch the RJ-11 (phone) port wires (conductors), the conductors of a cable connected to the RJ-11 port, or the associated circuit-board when the ringer is active. The ringer is activated by an incoming call.



Configuring the Cisco ATA for H.323

This section describes how to configure the Cisco ATA to operate with the H.323 signaling image and how the Cisco ATA obtains the latest signaling image.

You can configure the Cisco ATA for use with H.323 with any of the following methods:

- By using a TFTP server—This is the Cisco-recommended method for deploying a large number of Cisco ATAs. This method allows you to set up a unique Cisco ATA configuration file or a configuration file that is common to all Cisco ATAs. The Cisco ATA can automatically download its latest configuration file from the TFTP server when the Cisco ATA powers up, is refreshed or reset, or when the specified TFTP query interval expires.
- By using manual configuration:
 - Voice configuration menu—This is the method you must use if the process of establishing IP connectivity for the Cisco ATA requires changing the default network configuration settings. These settings are CDP, VLAN, and DHCP. You also can use the voice configuration menu to review all IP connectivity settings. The voice configuration menu can also be used when Web access is not available.
 - Web-based configuration—This method is convenient if you plan to deploy a small number of Cisco ATAs in your network. To use this method, the Cisco ATA must first obtain IP connectivity, either through the use of a DHCP server or by using the voice configuration menu to statically configure IP addresses.

This section contains the following topics:

- Default Boot Load Behavior, page 3-2—This section describes the process that the Cisco ATA follows by default when it boots up. It is very important to understand this process because, if your network environment is not set up to follow this default behavior, you need to make the applicable configuration changes. For example, by default, the Cisco ATA attempts to contact a DHCP server for the necessary IP addresses to achieve network connectivity. However, if your network does not use a DHCP server, you must manually configure various IP settings as described in this section.
- Specifying a Preconfigured VLAN ID or Disabling VLAN IP Encapsulation, page 3-3—This section includes a table of the parameters you can configure for VLAN and CDP settings.
- Steps Needed to Configure the Cisco ATA, page 3-5—This section provides tables that summarize the general configuration steps you must follow to configure the Cisco ATA.
- Configuring the Cisco ATA Using a TFTP Server, page 3-8—This section describes procedures for configuring the Cisco ATA by using a TFTP server, which is the recommended configuration method for the deployment of a large number of Cisco ATAs.
- Voice Configuration Menu, page 3-20—This section includes information on how to obtain basic network connectivity for the Cisco ATA and how to perform a factory reset if necessary.

- Cisco ATA Web Configuration Page, page 3-23—This section shows the Cisco ATA Web configuration page and contains a procedure for how to configure Cisco ATA parameters using this interface.
- Refreshing or Resetting the Cisco ATA, page 3-25—This section gives the procedure (via the Web configuration page) for refreshing or resetting the Cisco ATA so that your most recent configuration changes take effect immediately.
- Obtaining Cisco ATA Configuration File After Failed Attempt, page 3-26—This section gives the formula for how soon the Cisco ATA attempts to fetch its configuration file from the TFTP server after a failed attempt.
- Upgrading the H.323 Signaling Image, page 3-26—This section provides references to the various means of upgrading your Cisco ATA signaling image.

**Note**

The term *Cisco ATA* is used throughout this manual to refer to both the Cisco ATA 186 and the Cisco ATA 188, unless differences between the Cisco ATA 186 and Cisco ATA 188 are explicitly stated.

Default Boot Load Behavior

Before configuring the Cisco ATA, you need to know how the default Cisco ATA boot load process works. Once you understand this process, you will be able to configure the Cisco ATA by following the instructions provided in this section and in the sections that follow.

All Cisco ATAs are shipped with a bootload signaling-protocol image. However, because this image is not a fully functional signaling image, the image must be upgraded. The image is designed to be automatically upgraded by a properly configured TFTP server. To configure the Cisco ATA to automatically upgrade to the latest signaling image, see the “Upgrading the Signaling Image from a TFTP Server” section on page 8-1.

In addition, the Cisco ATA obtains its configuration file during the bootload process.

The following list summarizes the default Cisco ATA behavior during its boot-up process:

1. The Cisco ATA uses the Cisco Discovery Protocol (CDP) to discover which VLAN to enter. If the Cisco ATA receives a VLAN ID response from the network switch, the Cisco ATA enters that VLAN and adds 802.1Q VLAN tags to its IP packets. If the Cisco ATA does not receive a response with a VLAN ID from the network switch, then the Cisco ATA assumes it is not operating in a VLAN environment and does not perform VLAN tagging on its packets.

**Note**

If your network environment is not set up to handle this default behavior, make the necessary configuration changes by referring to the “Specifying a Preconfigured VLAN ID or Disabling VLAN IP Encapsulation” section on page 3-3.

2. The Cisco ATA contacts the DHCP server to request its own IP address.

**Note**

If your network environment does not contain a DHCP server, you need to statically configure various IP addresses so that the Cisco ATA can obtain network connectivity. For a list of parameters that you must configure to obtain network connectivity, see Table 3-6 on page 3-21. For instructions on how to use the voice configuration menu, which you must use to perform this configuration, see the “Voice Configuration Menu” section on page 3-20.

3. Also from the DHCP server, the Cisco ATA requests the IP address of the TFTP server.
4. The Cisco ATA contacts the TFTP server and downloads the Cisco ATA release software that contains the correct signaling image for the Cisco ATA to function properly.



Note If you are not using a TFTP server, you need to manually upgrade the Cisco ATA to the correct signaling image. For information on this procedure, see the “Upgrading the Signaling Image Manually” section on page 8-2.

5. The Cisco ATA looks for a Cisco ATA-specific configuration file (designated by the MAC address of the Cisco ATA and named `ata<macaddress>` with a possible file extension) on the TFTP server and downloads this file if it exists. For information about configuration file names, see the “Configuration Files that the ckgmt Tool Creates” section on page 3-13.
6. If the Cisco ATA does not find an `ata<macaddress>` configuration file, it looks for an `atadefault.cfg` configuration file and downloads this file if it exists. This file can contain default values for the Cisco ATA to use.



Note When the Cisco ATA is downloading its DHCP configuration, the function button on the top panel blinks.

Specifying a Preconfigured VLAN ID or Disabling VLAN IP Encapsulation

If you want the Cisco ATA to use a preconfigured VLAN ID instead of using the Cisco Discovery Protocol to locate a VLAN, or if you want to disable VLAN IP encapsulation, refer to Table 3-1 for a reference to the parameters and bits you may need to configure. Use the voice configuration menu to configure these parameters. (See the “Voice Configuration Menu” section on page 3-20 for instructions on using this menu.) Also, refer to Table 3-2 for a matrix that indicates which VLAN-related parameters and bits to configure depending on your network environment.



Note Bits are numbered from right to left, starting with bit 0.

Table 3-1 Parameters and Bits for Preconfiguring a VLAN ID

Parameter and Bits	Reference
OpFlags: <ul style="list-style-type: none"> • Bit 4—Enable the use of user-specified voice VLAN ID. • Bit 5—Disable VLAN encapsulation • Bit 6—Disable CDP discovery. 	OpFlags, page 5-34
VLANSetting: <ul style="list-style-type: none"> • Bits 0-2—Specify VLAN CoS bit value (802.1P priority) for TCP packets. • Bits 3-5—Specify VLAN CoS bit value (802.1P priority) for Voice IP packets • Bits 18-29—User-specified 802.1Q VLAN ID 	VLANSetting, page 5-12

Table 3-2 VLAN-Related Features and Corresponding Configuration Parameters

Feature	OpFlags Bit 4	OpFlags Bit 5	OpFlags Bit 6	VLANSetting Bits 18-29
Static VLAN	1	0	1	VLAN ID
CDP-acquired VLAN	0	0	0	N/A
No VLAN	N/A	1	N/A	N/A
No CDP	N/A	N/A	1	N/A
No CDP and no VLAN	0	1	1	N/A

N/A indicates that the variable is not applicable to the feature and the setting of this variable does not affect the feature.

Example

The following procedure shows you how to configure the OpFlags and VLANSetting parameters to allow the Cisco ATA to use a user-specified VLAN ID. In this example, the voice VLAN ID is 115 (in decimal format).

- Step 1** Set bits 4-6 of the OpFlags parameter to 1, 0, and 1, respectively. This setting translates to the following bitmap:

```
xxxx xxxx xxxx xxxx xxxx xxxx x101 xxxx
```

The remaining bits of the OpFlags parameter, using all default values, make up the following bitmap representation:

```
0000 0000 0000 0000 0000 0000 0xxx 0010
```

Therefore, the resulting value of the OpFlags parameter becomes the following bitmap representation:

```
0000 0000 0000 0000 0000 0000 0101 0010
```

In hexadecimal format, this value is 0x00000052.

Step 2 Set bits 18-29 of the VLANSetting parameter to voice VLAN ID 115. This setting translates to the following bitmap

```
xx00 0001 1100 11xx xxxx xxxx xxxx
```

where 000001110011 is the binary representation of the decimal value 115.

The remaining bits of the VLANSetting parameter, using all default values, make up the following representation:

```
00xx xxxx xxxx xx00 0000 0000 0010 1011
```

Therefore, the resulting value of the VLANSetting parameter becomes the following bitmap representation:

```
0000 0001 1100 1100 0000 0000 0010 1011
```

In hexadecimal format, this value is 0x01cc002b.



Note

If you are using the voice configuration menu to set the parameters, you must convert hexadecimal values to decimal values. For example, the OpFlags setting of 0x00000052 is equivalent to 82 in decimal format, and the VLANSetting of 0x01cc002b is equivalent to 30146603 in decimal format.

Steps Needed to Configure the Cisco ATA

This section contains the following topics:

- Basic Configuration Steps in a TFTP Server Environment, page 3-5
- Basic Configuration Steps in a Non-TFTP Server Environment, page 3-7

Basic Configuration Steps in a TFTP Server Environment

Table 3-3 shows the basic steps for configuring the Cisco ATA and making it operational in a typical H.323 environment, which includes a TFTP server.

Table 3-3 Basic Steps to Configure the Cisco ATA in a TFTP Environment

Action	Reference
1. Download the desired Cisco ATA release software zip file from the Cisco web site and store it on the TFTP server.	Setting Up the TFTP Server with Cisco ATA Software, page 3-8
2. Follow these basic steps to create a unique Cisco ATA configuration file, which actually entails creating two files: <ul style="list-style-type: none"> a. Create a Cisco ATA configuration text file that contains parameters that are common to all Cisco ATAs in your network. b. Create a unique Cisco ATA configuration text file that contains parameters that are specific to a Cisco ATA. <p>Make sure to use an include command in the unique configuration file to pull in values from the common configuration file.</p> c. Convert the unique configuration file to binary format. d. Place the unique binary configuration file on the TFTP server. 	Creating Unique and Common Cisco ATA Configuration Files, page 3-9
3. Optionally, create a default configuration file called atadefault.cfg, which the Cisco ATA will download from the TFTP server only if the unique Cisco ATA file called ata<macaddress> (with a possible file extension) does not exist on the TFTP server. For information about possible configuration file names, see the “Configuration Files that the cfgfmt Tool Creates” section on page 3-13.	atadefault.cfg Configuration File, page 3-17
4. Configure the upgradecode parameter so that the Cisco ATA will obtain the correct signaling image from the TFTP server when the Cisco ATA powers up.	Upgrading the Signaling Image from a TFTP Server, page 8-1
5. Configure the desired interval for the Cisco ATA to contact the TFTP server to check for a configuration-file update or an upgrade of the signaling image file.	Configuring the Cisco ATA Refresh Interval, page 4-9
6. Configure the method with which the Cisco ATA will locate the TFTP server at boot up time.	Configuring the Cisco ATA to Obtain its Configuration File from the TFTP Server, page 3-18
7. Power up the Cisco ATA.	
8. If you make configuration changes to the Cisco ATA or upgrade the signaling image on the TFTP server, you can refresh the Cisco ATA so that these changes take effect immediately. Otherwise, these changes will take effect when the specified interval (CfgInterval parameter value) for the TFTP query expires.	Refreshing or Resetting the Cisco ATA, page 3-25

Basic Configuration Steps in a Non-TFTP Server Environment

Table 3-4 shows the basic steps for configuring the Cisco ATA without using the TFTP server method.

Table 3-4 Basic Steps to Configure the Cisco ATA Without Using the TFTP Server Method

Action	Reference
<ol style="list-style-type: none"> 1. Download the desired Cisco ATA release software zip file from the Cisco web site: <ol style="list-style-type: none"> a. If you are a registered CCO user, go to the following URL: http://www.cisco.com/cgi-bin/tablebuild.pl/ata186 b. Download the zip file that contains the software for the applicable release and signaling image you are using. The contents of each file are described next to the file name. c. Extract the files to the desired location on your PC. <p> Note The file that contains the protocol signaling image has an extension of .zup.</p>	
<ol style="list-style-type: none"> 2. Manually upgrade the Cisco ATA to the correct signaling image. 	Upgrading the Signaling Image Manually, page 8-2
<ol style="list-style-type: none"> 3. Configure the Cisco ATA by using either one of the manual-configuration methods. 	<ul style="list-style-type: none"> • Voice Configuration Menu, page 3-20 • Cisco ATA Web Configuration Page, page 3-23
<ol style="list-style-type: none"> 4. Power up the Cisco ATA. 	

Configuring the Cisco ATA Using a TFTP Server

The TFTP method of configuration is useful when you have many Cisco ATA because you can use a TFTP server for remote, batch configuration of Cisco ATAs. A TFTP server can host one unique configuration file for each Cisco ATA.

This section contains the following topics:

- Setting Up the TFTP Server with Cisco ATA Software, page 3-8
- Configurable Features and Related Parameters, page 3-8
- Creating Unique and Common Cisco ATA Configuration Files, page 3-9
- atadefault.cfg Configuration File, page 3-17
- Configuring the Cisco ATA to Obtain its Configuration File from the TFTP Server, page 3-18

Setting Up the TFTP Server with Cisco ATA Software

This section provides the procedure for the Cisco ATA administrator to obtain the correct Cisco ATA software and set up the TFTP server with this software.

Procedure

-
- Step 1** If you are a registered CCO user, go to the following URL:
<http://www.cisco.com/cgi-bin/tablebuild.pl/ata186>
- Step 2** Download the zip file that contains the software for the applicable release and signaling image you are using. The contents of each file are described next to the file name. Save the zip file onto a floppy disc.



Note The file that contains the protocol signaling image has an extension of .zup.

- Step 3** Extract the signaling files onto the TFTP server. This should be the same TFTP server that will contain the binary Cisco ATA configuration file that you create (either `ata<macaddress>` with a possible file extension or `atadefault.cfg`). For information about possible configuration file names, see the “Configuration Files that the cgmfmt Tool Creates” section on page 3-13.
-

Configurable Features and Related Parameters

Table 4-1 on page 4-2 contains a list of all required H.323 parameters. These parameters must be properly configured for the Cisco ATA to work.

For descriptions of important Cisco ATA H.323 services that you can configure, and references to their configuration parameters, see the “Important Basic H.323 Services” section on page 4-1 and the “Additional H.323 Services” section on page 4-7.

Table 4-4 on page 4-12 lists, in alphabetical order, various features that you can configure for the Cisco ATA. Table 4-4 on page 4-12 also includes links to the related parameter that allows you to configure each of these features. Each link takes you to a detailed description of the parameter that includes its default values.

For an example of how to configure parameters for the TFTP Server configuration method, see the “Creating Unique and Common Cisco ATA Configuration Files” section on page 3-9.

Creating Unique and Common Cisco ATA Configuration Files

If you have many Cisco ATAs to configure, a good approach is to create two configuration files:

- One file that will contain only parameter values unique to a specific Cisco ATA.
- One file for parameters that will be configured with values common to a group of Cisco ATAs. If this file is updated, all Cisco ATA devices in this common group can obtain the new configuration data in a batch-mode environment.

The following procedure demonstrates the steps needed to create these configuration files.

**Note**

The parameters used in this section help illustrate the process of creating a unique Cisco ATA configuration file, and do not include all required H.323 parameters in the examples. See Chapter 4, “Basic and Additional H.323 Services,” for complete listings and descriptions of required parameters and additional configurable features. Also, refer back to Table 3-3 on page 3-6 for all main configuration steps.

Procedure

Step 1 Use the `h323_example.txt` file as a template for creating a text file of values that are common to one group of Cisco ATAs. The `h323_example.txt` file is included in the software-release zip file and contains all default values. This file is shown without its annotations in the “Configuration Text File Template” section on page 5-2.

Copy the `h323_example.txt` file and save it with a meaningful name, such as `common.txt`.

Step 2 Configure all common parameters by editing the text file as desired. For example, you might configure the following parameters:

```
UseTftp:1
DHCP:1
TftpURL:10.10.10.1
```

The settings in this example indicate that a group of Cisco ATAs is using the TFTP server with an IP address of 10.10.10.1 to obtain their configuration files. These Cisco ATAs will use a DHCP server to obtain their own IP addresses but not to obtain the TFTP server IP address (because the `TftpURL` parameter has a configured value).

Step 3 Save your changes.

- Step 4** Use the `h323_example.txt` file again, this time as a template for creating a text file of values that are specific to one Cisco ATA. For example, you might configure the following parameters:

```
UserID:8530709
GkorProxy:192.168.1.1
```

Save this file of Cisco ATA-specific parameters as:

```
ata<macaddress>.txt
```

where *macaddress* is the non-dotted hexadecimal version of the MAC address of the Cisco ATA you are configuring. This non-dotted hexadecimal MAC address is labeled on the bottom of most Cisco ATAs next to the word “MAC.” The file name must be exactly 15 characters long. (However, if this filename is supplied by the DHCP server, the name can be as long as 31 characters and can be any name with printable ASCII characters.)

If necessary, you can obtain the non-dotted hexadecimal MAC address by using the `atapname.exe` command. For information on using the `atapname.exe` command, see the “Using `atapname.exe` Tool to Obtain MAC Address” section on page 3-11. That section includes an example of a dotted decimal MAC address and its corresponding non-dotted hexadecimal address.



Note The `ata<macaddress>.txt` file should contain only those parameters whose values are different from the file of common parameters. Parameter values in the `ata<macaddress>` configuration file will overwrite any manually configured values (values configured through the web or voice configuration menu) when the Cisco ATA powers up or refreshes.

- Step 5** On the top line of the `ata<macaddress>.txt` file, add an **include** command to include the name of the common-parameters file, and save the file.

```
include:common.txt
UserID:8530709
GkorProxy:192.168.1.1
```

- Step 6** Run the `cfgfmt.exe` tool, which is bundled with the Cisco ATA software, on the `ata<macaddress>.txt` text file to generate the binary configuration file. If you wish to encrypt the binary file, see the “Using Encryption With the `cfgfmt` Tool” section on page 3-12.

The syntax of the `cfgfmt` program follows:

Syntax

```
cfgfmt [Encryption options] -h323 -tptag.dat input-text-file output-binary-file
```

- Encryption options are described in the “Using Encryption With the `cfgfmt` Tool” section on page 3-12.
- `h323` (for H.323) is the protocol you are using, which you must specify so that the `cfgfmt` tool will include only the applicable protocol in the converted output binary file.
- The `ptag.dat` file, provided with the Cisco ATA software version you are running, is used by `cfgfmt.exe` to format a text input representation of the parameter/value pairs to its output binary representation. Be sure this file resides in the same directory from which you are running the `cfgfmt` program.
- `input-text-file` is the input text file representation of the Cisco ATA configuration file.
- `output-binary-file` is the final output binary file that Cisco ATA uses as the TFTP configuration file.

Example

```
cfgfmt -h323 -tptag.dat ata0a141e28323c.txt ata0a141e28323c
```

This example is based on a Cisco ATA MAC address of 10.20.30.40.50.60, which converts to the two-digit, lower-case hexadecimal representation of each integer as 0a141e28323c.

When you convert the ata<macaddress>.txt file to a binary file, the binary file will merge the two text files to form one Cisco ATA-specific binary configuration file for your Cisco ATA.

If the same parameter is configured with different values in these two files, the value in the ata<macaddress>.txt file takes precedence over the value in the common.txt file.

- Step 7** Store all binary configuration file(s) in the TFTP server root directory. For information about possible configuration file names, see the “Configuration Files that the cfgfmt Tool Creates” section on page 3-13.

When the Cisco ATA powers up, it will retrieve its configuration file(s) from the TFTP server.

- Step 8** If you want to make configuration changes after boot up, repeat the process of creating or editing the text files containing the desired parameters, then converting the ata<macaddress>.txt text file to the binary file(s) and storing the binary file(s) on the TFTP server. For the configuration changes to take effect immediately, refresh the Cisco ATA. (See the “Refreshing or Resetting the Cisco ATA” section on page 3-25.)

After being refreshed, the Cisco ATA will download the updated ata<macaddress> configuration file(s).



Note If you do not perform a refresh procedure, the Cisco ATA will update its configuration the next time it contacts the TFTP server, which is based on the configured value of the CfgInterval parameter.

Using ataname.exe Tool to Obtain MAC Address

This bundled tool is useful for converting the dotted decimal version of the Cisco ATA MAC address (available on the Cisco ATA Web configuration page or from the voice configuration menu code **24#**) to its default Cisco ATA profile name. This name has the following format:

```
ataxxxxxxxxxxxx
```

where each *xx* is the two-digit, lower-case hexadecimal representation of each integer in the dotted, decimal version of the Cisco ATA MAC address. This is the name you use for the unique Cisco ATA binary configuration file.

The following command and output show an example of this command.

Command Example

```
atapname.exe 10.20.30.40.50.60
```

Command Output

```
ata0a141e28323c
```



Note

The same functionality is available from the voice configuration menu (voice menu code **84#**), which will announce the Cisco ATA profile name.

Using Encryption With the *cfgfmt* Tool

The `EncryptKey` or `EncryptKeyEx` parameter can be used to encrypt binary files that are transferred over TFTP. You can change encryption keys for each Cisco ATA so that only one specific Cisco ATA can decode the information.

Cisco strongly recommends using the `EncryptKeyEx` parameter for encryption because this parameter provides a stronger encryption than the `EncryptKey` parameter that was used in Cisco ATA software releases prior to release 2.16.

You must use version 2.3 of the *cfgfmt* configuration-file generation tool to use the new `EncryptKeyEx` parameter. This tool comes bundled with Cisco ATA software version 3.0. To verify that you have version 2.3 of the *cfgfmt* tool type the following command:

```
cfgfmt
```

The version number of the *cfgfmt* tool will be returned.

You can configure the `EncryptKeyEx` parameter by using the Cisco ATA Web configuration page or by using the TFTP configuration method. (For more information, see the “`EncryptKeyEx`” section on page 5-7.)

You can configure the `EncryptKey` parameter by using the Cisco ATA Web configuration page, the voice configuration menu, or by using the TFTP configuration method. (For more information, see the “`EncryptKey`” section on page 5-6.)

By default, the Cisco ATA-specific `ata<macaddress>` configuration file(s) are not encrypted. If encryption is required, however, you must manually configure the `EncryptKeyEx` or `EncryptKey` parameter before you boot up the Cisco ATA so that the TFTP method is secure. The Cisco ATA uses the RC4 cipher algorithm for encryption.



Note

Because the factory-fresh ATA cannot accept encrypted configuration files, the first unencrypted file, if intercepted, can easily be read. (You would still have to know the data structure format in order to decode the binary information from the unencrypted file.) Therefore, the new encryption key in the unencrypted file can be compromised.



Note

For security reasons, Cisco recommends that you set the `UIPassword` parameter (if desired) in the configuration file and not by using one of the manual configuration methods.

This section contains the following topics:

- Configuration Files that the cfgfmt Tool Creates, page 3-13
- cfgfmt Tool Syntax and Examples, page 3-14

Configuration Files that the cfgfmt Tool Creates

The number of output binary configuration files that the Cisco ATA produces is dependent on two factors:

- Which encryption key parameter is used—EncryptKey or EncryptKeyEx
- The total size of the binary output

Table 3-5 shows the names of the binary files that can be generated. One, two or four files can be generated.



Note

<macaddress> in Table 3-5 is the MAC address of the Cisco ATA.



Note

If you are creating an *atadefault* configuration file, the generated binary file name will be *atadefault.cfg.x* if you encrypt the text file with the EncryptKeyEx parameter; the binary file name will be *atadefault.cfg* if you do not use the EncryptKeyEx parameter to encrypt the text file. For information on creating an *atadefault* configuration file, see the “atadefault.cfg Configuration File” section on page 3-17.

Table 3-5 Configuration Files that the Cisco ATA May Generate

Value of EncryptKeyEx Parameter	Total Binary Output Size Less Than or Equal to 2,000 Bytes	Total Binary Output Size Greater Than 2,000 Bytes
0	ata<macaddress>	ata<macaddress> ata<macaddress>.ex
Non-zero	ata<macaddress> ata<macaddress>.x	ata<macaddress> ata<macaddress>.ex ata<macaddress>.x ata<macaddress>.xex



Note

Place all generated binary configuration files onto the TFTP server.

cfgfmt Tool Syntax and Examples

The syntax of the `cfgfmt` tool follows:

Syntax

```
cfgfmt [options] input output
```

Syntax Definitions—Options

- `-eRc4Passwd`—This option directs the Cisco ATA to use `Rc4Passwd` as the key (up to eight hexadecimal characters) to encrypt or decrypt the input text file. However, if the Cisco ATA `EncryptKey` parameter in the input text file is not 0, then the value of that parameter is used to encrypt the output binary file, and `Rc4Passwd` is ignored. The `-e` portion of this option means that the Cisco ATA will use the *weaker* encryption method.
- `-E`—This option directs the Cisco ATA to *not* use the value of the `EncryptKey` parameter, as set in the input text file, to encrypt the output binary configuration file.
- `-xRc4Passwd`—This option directs the Cisco ATA to use `Rc4Passwd`, which must be a hexadecimal string of as many as 64 characters, as the key to encrypt or decrypt the input text file. However, if the Cisco ATA `EncryptKeyEx` parameter in the input text file is not 0, then the value of that parameter is used to encrypt the output binary file, and `Rc4Passwd` is ignored. The `-x` portion of this option means that the Cisco ATA will use the *stronger* encryption method.
- `-X`—This option directs the Cisco ATA to *not* use the value of the `EncryptKeyEx` parameter, as set in the input text file, to encrypt the output binary configuration file.
- `-tPtag.dat`—This file, provided with the Cisco ATA software version you are running, is used by the `cfgfmt` tool to format a text input representation of the parameter/value pairs to its output binary representation. Be sure this file resides in the same directory from which you are running the `cfgfmt` program.
- `-sip`—Specify this tag if you are using the SIP protocol so that the `cfgfmt` tool will include only the SIP protocol parameters in the converted output binary file.
- `-h323`—Specify this tag if you are using the H.323 protocol so that the `cfgfmt` tool will include only the H.323 protocol parameters in the converted output binary file.
- `-mgcp`—Specify this tag if you are using the MGCP protocol so that the `cfgfmt` tool will include only the MGCP protocol parameters in the converted output binary file.
- `-sccp`—Specify this tag if you are using the SCCP protocol so that the `cfgfmt` tool will include only the SCCP protocol parameters in the converted output binary file.
- `-g`—This tag omits sensitive parameters in an `ata<macaddress>` file that was created with a version of the `cfgfmt` tool prior to version 2.3.

Some parameters, specified in the `ptag.dat` file used by the `cfgfmt` tool, are marked as sensitive information (these parameters could include `UIPassword`, `UID`, `PWD0`). These parameters are not included in the output binary file if the `-g switch` is specified in the `cfgfmt` syntax.

Syntax Definitions—Required Parameters

- `Input`—This is the input text file representation of the Cisco ATA configuration file.
- `Output`—This is the final output binary file that Cisco ATA uses as the TFTP configuration file.

Syntax examples

The `cfgfmt.exe` syntax affects how the `EncryptKeyEx` or `EncryptKey` parameters are used, as shown in the following examples. In these examples, `input-text-file` is the `ata<macaddress>.txt` file that you will convert to binary to create the `ata<macaddress>` configuration file(s) for the Cisco ATA; `output-binary-file` is that binary `ata<macaddress>` file, and `Secret` is the encryption key.

- `cfgfmt -h323 -tptag.dat input-text-file output-binary-file`

If `input-text-file` sets the Cisco ATA `EncryptKey` parameter to 0, then `output-binary-file` is not encrypted. If the `input-text-file` sets `EncryptKey` to a non-zero value, then `output-binary-file` is encrypted with that value.

- `cfgfmt -X -h323 -tptag.dat input-text-file output-binary-file`

This is an example of how you might perform encryption on a first-time Cisco ATA.

The `-X` (uppercase) option means that any value specified for the Cisco ATA `EncryptKeyEx` parameter in `input-text-file` is ignored. However, because `Secret` is not specified in this example, `output-binary-file` is not encrypted. Nevertheless, the `EncryptKeyEx` parameter and its value, if specified in `input-text-file`, will be included in `output-binary-file` for possible encryption at a later time. The next time the Cisco ATA fetches the configuration file from the TFTP server, the file will be encrypted with `Secret`.

- `cfgfmt -X -xSecret -h323 -tptag.dat input-text-file output-binary-file`

This is an example of changing the encryption key from one key to another key.

The `-X` (uppercase) option means that any value specified for the Cisco ATA `EncryptKeyEx` parameter in `input-text-file` is ignored and the `output-binary-file` is encrypted with the `Secret` key. However, the `EncryptKeyEx` parameter and its value, if specified in `input-text-file`, will be included in `output-binary-file`.

Examples of Upgrading to Stronger Encryption Key

This section contains two examples of how you would upgrade your Cisco ATA configuration to use the stronger encryption method if the current Cisco ATA firmware version was a version earlier than version 2.16.2. Versions earlier than 2.16.2 do not support the stronger `EncryptKeyEx` parameter.

Example 1

In this example, the Cisco ATA has not yet been deployed, but its firmware version is earlier than 2.16.2. Therefore, the Cisco ATA will upgrade to to firmware version 3.0 to use the `EncryptKeyEx` parameter as its encryption key.

The Cisco ATA in this example has a MAC address of 102030405060.

Perform the following steps:

Procedure

-
- Step 1** Create a file called `ata102030405060.txt` by using the applicable `example.txt` file provided with the Cisco ATA software. (For example, for H.323, the `example.txt` file is called `h323_example.txt`.)
 - Step 2** Modify the `ata102030405060.txt` file with desired parameter values. The value of the `EncryptKey` parameter should be 0.

- Step 3** Set the value of the `EncryptKeyEx` parameter to the chosen encryption key with which you want the output binary file to be encrypted. In the `EncryptKeyEx` parameter specified in the configuration file, you can also restrict the `EncryptKeyEx` value to apply only to the Cisco ATA with a particular MAC address. For example, if the chosen key value is `231e2a7f10bd7fe`, you can specify `EncryptKeyEx` as:

```
EncryptKeyEx:231e2a7f10bd7fe/102030405060
```

This means that only the Cisco ATA with the MAC address `102030405060` will be allowed to apply this `EncryptKeyEx` value to its internal configuration.

- Step 4** Update the `upgradecode` parameter to instruct the Cisco ATA to upgrade to firmware version 3.0 by means of TFTP configuration. The `upgradecode` parameter is described in Chapter 8, “Upgrading the Cisco ATA Signaling Image.”

- Step 5** Run the `cfgfmt` tool as follows:

```
cfgfmt -g ata102030405060.txt ata102030405060
```

This will generate the following two binary configuration files:

- `ata102030405060`
- `ata102030405060.x`

`ata102030405060` is unencrypted.

`ata102030405060.x` is encrypted with `EncryptKeyEx` value.

- Step 6** Place these two files on the TFTP server that the Cisco ATA will contact for its configuration files.

When the Cisco ATA powers up, it will obtain its IP address from the DHCP server. If the DHCP server specifies the TFTP server address, the Cisco ATA will contact the TFTP server obtained from DHCP because the Cisco ATA is not preconfigured with a TFTP server address. The boot process is as follows:

- a. The Cisco ATA downloads the configuration file `ata102030405060` from the TFTP server.
- b. The Cisco ATA applies parameter values in the file `ata102030405060` to its internal configuration while ignoring the `EncryptKeyEx` parameter (because the older version of the Cisco ATA does not yet recognize the `EncryptKeyEx` parameter).
- c. The Cisco ATA upgrades to the 3.0 firmware load.
- d. The Cisco ATA reboots.
- e. The Cisco ATA again downloads the configuration file `ata102030405060`.
- f. The Cisco ATA applies the value of the `EncryptKeyEx` parameter to its internal configuration.
- g. The Cisco ATA reboots.
- h. The Cisco ATA `EncryptKeyEx` value is in effect, so from this point forward the Cisco ATA will download the `ata102030405060.x` file at each reboot and each time the value configured in the `CfgInterval` parameter expires.



Note

Although `EncryptKeyEx` is encrypted in the `ata<macaddress>` file, and the `ata<macaddress>` file does not contain other sensitive information, Cisco recommends that for absolute security you pre-configure the Cisco ATA as described in this example for a private network. Alternatively, you should remove `ata<macaddress>` once `EncryptKeyEx` takes effect.

Example 2

In this example, a new Cisco ATA has already been deployed (with the *EncryptKey* value set) with a firmware version earlier than 2.16.2. The Cisco ATA needs to be upgraded to version 2.16.2 firmware or greater to use *EncryptKeyEx* parameter to encrypt its configuration file.

In this scenario, you would follow the same procedure as in Example 1, except that you would need to set the *EncryptKey* value to the previously configured *EncryptKey* value. The difference is that the *ata<macaddress>* file is now encrypted with *EncryptKey* because the Cisco ATA expects the *ata<macaddress>* file to be encrypted with *EncryptKey*. The Cisco ATA can then begin using the *ata<macaddress>.x* file that is encrypted with the *EncryptKeyEx* parameter.

atadefault.cfg Configuration File

You can create a configuration file, called *atadefault.cfg*, that is common to all Cisco ATAs. This configuration file is applied to a Cisco ATA only if a unique configuration file (such as *ata<macaddress>*) does not exist for the Cisco ATA on the TFTP server during the Cisco ATA power-up procedure.

You can use the *atadefault.cfg* file to provide limited functionality for when you first install the Cisco ATA. For example, if your service provider provides the ethernet connection and VoIP telephony service, you may need to call customer service to activate the service. If the *atadefault.cfg* file is configured to provide a direct connection to the customer service center, you can simply pick up the telephone and wait to be connected without using your regular phone.

The following procedure illustrates how to create the Cisco ATA default configuration file, convert it to the required binary format that the Cisco ATA can read, and store it on the TFTP server so that the Cisco ATA will download it during the boot-up process:

Procedure

-
- Step 1** Make a copy of the *h323_example.txt* file and rename it *atadefault.txt*.
 - Step 2** Make the desired configuration changes by editing the *atadefault.txt* file, then save the file.
 - Step 3** Convert the *atadefault.txt* file to a binary file by running the *cfgfmt.exe* tool, which is bundled with the Cisco ATA software.



Note If you wish to encrypt the binary file for security reasons, see the “Using Encryption With the *cfgfmt* Tool” section on page 3-12. If you encrypt the file using the *EncryptKeyEx* parameter, the resulting binary file will be called *atadefault.cfg.x*; if not encrypted with the *EncryptKeyEx* parameter the resulting binary file name will be *atadefault.cfg*.

- Step 4** Store the binary *atadefault.cfg* (or *atadefault.cfg.x*) configuration file in the TFTP server root directory. During the boot-up process, the Cisco ATA will download this file as its configuration file unless it first finds a Cisco ATA-specific configuration file named for the MAC address of the Cisco ATA.
-

Configuring the Cisco ATA to Obtain its Configuration File from the TFTP Server

This section describes three methods for how the Cisco ATA contacts the TFTP server to obtain its configuration file:

- Using a DHCP Server, page 3-18
 - The Cisco ATA contacts the DHCP server, which provides the IP address of the TFTP server
 - The Cisco ATA uses the DHCP server but the DHCP server does not know about the TFTP server
- Without Using a DHCP Server, page 3-20

Using a DHCP Server

When using a DHCP server, configuration settings vary depending on whether or not the DHCP server is under the control of the Cisco ATA system administrator or the service provider. The simplest configuration is when the DHCP server is under the control of the Cisco ATA administrator, in which case the DHCP server provides the IP address of the TFTP server. Depending on who controls the DHCP server, follow the applicable configuration procedure:

- Procedure if DHCP Server is Under Control of Cisco ATA Administrator, page 3-18
- Procedure if DHCP Server is not Under Control of Cisco ATA Administrator, page 3-19

This section also includes the topic:

- Other DHCP Options You Can Set, page 3-19



Note

If no DHCP server is found and the Cisco ATA is programmed to find one, the function button continues to blink.

Procedure if DHCP Server is Under Control of Cisco ATA Administrator

Procedure

Step 1 On the DHCP server, set one of the following two options:

- DHCP option 150 (TFTP server IP address)
- Standard DHCP option 66 (TFTP server name)

If you use DHCP option 150, the Cisco ATA will ignore DHCP option 66. However, if you use DHCP option 66, you must turn off DHCP option 150 or set its value to 0.



Note

You can turn off the DHCP option 150 request by using the Cisco ATA OpFlags parameter (see the “OpFlags” section on page 5-34).

Step 2 Make sure to use default values for the following Cisco ATA parameters:

- TftpURL=0
- UseTftp=1
- DHCP=1

This completes the parameter settings and DHCP options you need to configure for this procedure. The Cisco ATA will contact the DHCP server for the IP address of the TFTP server that contains the Cisco ATA configuration file.

Procedure if DHCP Server is not Under Control of Cisco ATA Administrator

This is the procedure to use if the DHCP server is not under the control of the Cisco ATA administrator, which means that the URL of the TFTP server must be manually configured.

Procedure

- Step 1** Using the voice configuration menu, set the parameter TftpURL to the IP address or URL of the TFTP server. For more information on setting the TftpURL parameter, see the “TftpURL” section on page 5-5. For information about using the Cisco ATA voice configuration menu, see the “Voice Configuration Menu” section on page 3-20.



Note If you are not using a DHCP server to provide the TFTP server location, you *must* manually configure the TftpURL. You can do this by using the voice configuration menu without first obtaining network connectivity for the Cisco ATA. If you want to configure this value using the Web configuration page, you first must obtain network connectivity by using the voice configuration menu to statically configure IP address information (see the “Voice Configuration Menu” section on page 3-20).

- Step 2** Use the default value of 1 for the Cisco ATA parameter DHCP.

- Step 3** Use the default value of 1 for the Cisco ATA parameter UseTftp.

This completes the parameter settings you need to configure for this procedure. The Cisco ATA will contact the manually configured TFTP server that contains the Cisco ATA configuration file.

Other DHCP Options You Can Set

The following parameters can also be configured with DHCP:

- Boot file name of DHCP header—The ata<macaddress> binary Cisco ATA configuration file, which can have a maximum of 31 characters and can be any name with printable ASCII characters
- Client PC address
- DHCP option 1—Client Subnet Mask
- DHCP option 3—Routers on the client’s subnet
- DHCP option 6—One or two Domain Name servers
- DHCP option 42—One or two Network Time Protocol servers



Note DHCP options 43 and 60 are set by the Cisco ATA. Option 43 specifies the protocol and option 60 identifies the vendor class of the Cisco ATA box.

Without Using a DHCP Server

Use the following procedure if you are not using a DHCP server in your environment but are still using a TFTP server to obtain the Cisco ATA configuration file:

Procedure

-
- Step 1** Set the DHCP parameter to 0.
- Step 2** Set the UseTFTP parameter to 1.
- Step 3** Set the Cisco ATA parameter TftpURL to the IP address or URL of the TFTP server. For more information on setting the TftpURL parameter, see the “TftpURL” section on page 5-5.



Note If you are not using a DHCP server to provide the TFTP server location, you must manually enter the TftpUrl using either the voice configuration menu or the Web configuration page.

- Step 4** If you have already done so, statically configure the following parameters using the voice configuration menu (see the “Voice Configuration Menu” section on page 3-20). These are the parameters you need to configure for the Cisco ATA to obtain network connectivity:

- StaticIP
- StaticRoute
- StaticNetMask

Other parameters that are normally supplied by DHCP may be provided statically by configuring their values. These parameters are:

- DNS1IP
- DNS2IP
- NTPIP
- AltNTPIP
- Domain

This completes the parameter settings you need to configure in order for the Cisco ATA to contact the TFTP server (without using DHCP) that will contain the configuration file for the Cisco ATA.

Voice Configuration Menu

The main reasons to use the voice configuration menu are to establish IP connectivity for the Cisco ATA if a DHCP server is not being used in your network environment, and to reset the Cisco ATA to its factory values if necessary. You can also use the voice configuration menu if you need to configure a small number of parameters or if the web interface and TFTP configuration are not available.

**Note**

Do not use the voice configuration menu to attempt to change any values that you configured by means of the TFTP configuration file method. Whenever the Cisco ATA refreshes, it downloads its `ata<macaddress>` configuration file or `atadefault.cfg` default configuration file from the TFTP server, and the values in either of these files will overwrite the values of any corresponding parameters configured with the voice configuration menu.

See Chapter 5, “Parameters and Defaults,” for a complete list of parameters and their definitions. Also see Table 4-4 on page 4-12 for an alphabetical listing of configurable features and references to their corresponding parameters.

This section contains the following topics:

- Using the Voice Configuration Menu, page 3-21
- Entering Alphanumeric Values, page 3-22
- Resetting the Cisco ATA to Factory Default Values, page 3-23

Using the Voice Configuration Menu

To manually configure the Cisco ATA by using the voice configuration menu and the telephone keypad, perform the following steps:

Procedure

- Step 1** Connect an analog touch-tone phone to the port labeled **Phone 1** on the back of the Cisco ATA.
- Step 2** Lift the handset and press the function button located on the top of the Cisco ATA. You should receive the initial voice configuration menu voice prompt.
- Step 3** Using the telephone keypad, enter the voice menu code for the parameter that you want to configure or the command that you want to execute, then press #. For a list of voice menu codes, see Appendix B, “Voice Menu Codes.”

Table 3-6 lists the menu options that you need to configure basic IP connectivity for the Cisco ATA, after which you can use the Cisco ATA web configuration page to configure additional parameters.



Note If you are using the voice configuration menu to statically configure the Cisco ATA IP address, you must disable DHCP by setting its value to 0.

Table 3-6 Parameters that Provide Basic IP Connectivity for the Cisco ATA

Voice Menu Number	Features
1	StaticIP—IP address of the Cisco ATA.
2	StaticRoute—Default gateway for the Cisco ATA to use.
10	StaticNetMask—Subnet mask of the Cisco ATA.
20	DHCP—Set value to 0 to disable the use of a DHCP server; set value to 1 to enable DHCP.
21	Review the IP address of the Cisco ATA.

Table 3-6 Parameters that Provide Basic IP Connectivity for the Cisco ATA (continued)

Voice Menu Number	Features
22	Review the default router for the Cisco ATA to use.
23	Review subnet mask of the Cisco ATA.

Step 4 Follow the voice prompts and enter the appropriate values, then press the # key.



Note Use the * key to indicate a delimiter (dot). For example, to enter an IP address of 192.168.3.1, you would enter 192*168*3*1 on your telephone keypad.



Note When entering values for a field that contains a hexadecimal value, you must convert the hexadecimal value to a decimal value in order to enter it into the voice configuration menu system. For example, to enter the hexadecimal value 0x6A, you would enter the number 106 on the telephone keypad.

The voice configuration menu repeats the value you entered, then prompts you to press one of the following keys:

- 1=Change your entered value
- 2=Review your entered value
- 3=Save your entered value
- 4=Review the current saved value

Step 5 Cisco strongly recommends that you set a password. Use the voice menu code 7387277 (SETPASS) to configure a password through the voice configuration menu, after which you are prompted for the password whenever you attempt to change a parameter value.

Step 6 After completing the configuration through the voice configuration menu, press the # key to exit.

Step 7 Hang up the telephone. The Cisco ATA configuration refreshes. The function button fast-blinks when the refresh completes.

Entering Alphanumeric Values

Some voice configuration menu options require you to enter alphanumeric characters. Alphanumeric entry differs from numeric entry because you must press # after each character selected.

If you need to enter an alphanumeric value, the voice prompt tells you to enter an alphanumeric value; otherwise, enter a numeric value (0 to 9).

Table 3-7 lists the keys on a telephone keypad and their respective alphanumeric characters.

Using Table 3-7 as a guide, enter the appropriate number key on the telephone keypad as many times as needed to select the number, letter, or symbol required. For example, to enter 58sQ, you would enter:

5 # 8 # 7 7 7 7 7 # 7 7 7 7 7 7 # #

Table 3-7 Alphanumeric Characters

Key	Alphanumeric Characters
1	1 ./_ \ @ *space return + - ! , ? ~ ^ # = \$ % ' " < > [] ; : { } () &
2	2 a b c A B C
3	3 d e f D E F
4	4 g h i G H I
5	5 j k l J K L
6	6 m n o M N O
7	7 p q r s P Q R S
8	8 t u v T U V
9	9 w x y z W X Y Z
0	0

Resetting the Cisco ATA to Factory Default Values

It is possible that you may, under some circumstances, want to reset the Cisco ATA to its factory default values. For example, this is the only way to recover a forgotten password without contacting your Cisco representative.

To perform a factory reset, you must use the voice configuration menu and follow these steps:

Procedure

-
- Step 1** Press the function button on the Cisco ATA.
 - Step 2** Press the digits **322873738 (FACTRESET)** then press **#** on your telephone keypad.
 - Step 3** Press ***** on your telephone keypad to confirm that you want to reset the Cisco ATA, then hang up the phone.
-

Cisco ATA Web Configuration Page

You can use the Cisco ATA web configuration page in a non-TFTP configuration environment, or in a TFTP configuration environment as a read-only record of individual customer parameters.

You can display the most recent Cisco ATA configuration file from the TFTP server by opening your web browser and typing the following:

http://<ipaddress>/refresh

where *ipaddress* is the IP address of the Cisco ATA.

Figure 3-1 shows an example of the Cisco ATA web configuration page, which displays all configurable parameters.

**Note**

Do not use the web configuration page to attempt to change any values that you configured by means of the TFTP configuration file method. Whenever the Cisco ATA refreshes, it downloads its `ata<macaddress>` configuration file(s) or `atadefault.cfg` default configuration file from the TFTP server, and the values in either of these files will overwrite the values of any corresponding parameters configured with the web configuration method.

Figure 3-1 Cisco ATA Web Configuration Page

UIPassword:	*	UseTftp:	0
TftpURL:	0	CfgInterval:	3600
EncryptKey:	*	EncryptKeyEx:	00000000000000000000
Dhcp:	1	StaticIP:	0.0.0.0
StaticRoute:	0.0.0.0	StaticNetMask:	255.255.255.0
UID0:	0	PWD0:	*
UID1:	0	PWD1:	*
GkOrProxy:	0	Gateway:	0
UseLoginID:	0	LoginID0:	0
LoginID1:	0	AltGk:	0
AltGkTimeOut:	0	GkTimeToLive:	300
GkId:	.	MediaPort:	16384
LBRCodec:	0	AudioMode:	0x00150015
RxCodec:	1	TxCodec:	1
NumTxFrames:	2	CallFeatures:	0xfffff
PaidFeatures:	0xfffff	CallerIdMethod:	0x00019e60
FeatureTimer:	0x00000000	FeatureTimer2:	0x0000001e
Polarity:	0x00000000	ConnectMode:	0x00060400
AutMethod:	0x00000000	TimeZone:	17
NTPIP:	0.0.0.0	AltNTPIP:	0.0.0.0
DNS1IP:	0.0.0.0	DNS2IP:	0.0.0.0
TOS:	0x000068b8	SigTimer:	0x01418564
OpFlags:	0x00000002	VLANSetting:	0x0000002b
FXSInputLevel:	-1	FXSOutputLevel:	-4
NPrintf:	192.168.3.105.9300	TraceFlags:	0x00000001
SyslogIP:	0.0.0.0.514	SyslogCtrl:	0x00000000
RingOnOffTime:	2,4,25	IPDialPlan:	1
DialPlan:	*St4- #St4- 911 1>#t8.r9t2-	DialPlanEx:	0
DialTone:	2,31538,30831,1380,1740,	BusyTone:	2,30467,28959,1191,1513,
ReorderTone:	2,30467,28959,1191,1513,	RingBackTone:	2,30831,30467,1943,2111,
CallWaitTone:	1,30831,0,5493,0.0,2400,2	AlertTone:	1,30467,0,5970,0.0,480,48
CallCmd:	At:AH,BS,NA,CS,NA,Dt,E	CFGID:	0x00000000

70667

You can access the web configuration page from any graphics-capable browser, such as Microsoft Internet Explorer or Netscape. This provides easy initial access to the Cisco ATA configuration within the administrator's private network.

Follow these steps to set parameters using the web configuration page:

Procedure

Step 1 Make sure that your PC and the Cisco ATA are already networked and visible to each another.

Step 2 Open your web browser.

Step 3 Enter the URL for your configuration page. The default URL for the web server is:

http://IP Address/dev

For example, the configuration page for a Cisco ATA with the IP address 192.168.3.225 is:

http://192.168.3.225/dev

Step 4 Select the values for the items that you want to configure. See Chapter 5, "Parameters and Defaults," for a complete list of parameters and their definitions. Also see Table 4-4 on page 4-12 for an alphabetical listing of configurable features and references to their corresponding parameters.



Note

Cisco strongly recommends that you set a password. Use the UIPassword parameter to configure a password, after which you are prompted for the password whenever you attempt to change a parameter value. Configuration parameters cannot be accessed through the voice configuration menu if the password contains one or more letters and can be changed only by using the web interface or the TFTP configuration method.

Step 5 Click **apply** to save your changes.

The Cisco ATA automatically refreshes its configuration.

Step 6 Close your web browser.

Refreshing or Resetting the Cisco ATA

Whenever you make configuration changes to your Cisco ATA configuration file, you can refresh or reset the Cisco ATA for these configuration changes to immediately take effect. If you do not refresh or reset the Cisco ATA, the configuration changes will take effect the next time the Cisco ATA contacts the TFTP server, which occurs based on the configured value of the CfgInterval parameter.



Note

A refresh procedure will update the Cisco ATA configuration file. A reset procedure will also update the Cisco ATA configuration file, and will additionally power-down and power-up the Cisco ATA. A reset should not be necessary if your only goal is to update the configuration file.

Procedure to Refresh the Cisco ATA

To refresh the Cisco ATA, enter the following command from your web browser:

```
http://<ipaddress>/refresh
```

where *ipaddress* is the IP address of the Cisco ATA that you are refreshing.

Procedure to Reset the Cisco ATA

To reset the Cisco ATA, enter the following command from your web browser:

```
http://<ipaddress>/reset
```

where *ipaddress* is the IP address of the Cisco ATA that you are resetting.

Obtaining Cisco ATA Configuration File After Failed Attempt

The Cisco ATA uses the following formula for determining how soon to contact the TFTP server for the Cisco ATA configuration file after a failed attempt at getting the file. The result of the formula is called the *random back-off amount*.

```
random back-off amount = CfgInterval + random(min(1800, CfgInterval))
```

where

- *CfgInterval* is the value of the CfgInterval configuration parameter (in seconds). For more information about this parameter, see the “CfgInterval” section on page 5-6.
- random(x) function yields a value between 0 and x-1.
- min(x,y) function yields the smaller value of x and y.

Upgrading the H.323 Signaling Image

For instructions on how to upgrade the Cisco ATA to the most recent H.323 signaling image, refer to the following list:

- To use the recommended TFTP method of upgrading the Cisco ATA, see the “Upgrading the Signaling Image from a TFTP Server” section on page 8-1.
- In the rare instance that you are not using the TFTP server to configure the Cisco ATA and to obtain software upgrades, you must manually upgrade to the latest signaling image immediately after the Cisco ATA boots up. In this case, see the “Upgrading the Signaling Image Manually” section on page 8-2.



Basic and Additional H.323 Services

This section provides information about key basic and additional H.323 services that the Cisco ATA supports:

- Important Basic H.323 Services, page 4-1—This section includes a list of parameters that you must configure in order for the Cisco ATA to function in an H.323 environment.
- Additional H.323 Services, page 4-7—This section contains information about additional, commonly used H.323 features, with references to the parameters for configuring these services.
- Complete Reference Table of all Cisco ATA H.323 Services, page 4-12—This section contains a complete listing of Cisco ATA services supported for H.323, and includes cross references to the parameters for configuring these services.



Note

The term *Cisco ATA* refers to both the Cisco ATA 186 and the Cisco ATA 188, unless otherwise stated.

Important Basic H.323 Services

This section provides descriptions and cross references for configuring required H.323 parameters and also for configuring important H.323 services:

- Required Parameters, page 4-1
- Setting Up User IDs for the Cisco ATA, page 4-3
- Using the Cisco ATA with an H.323 Gatekeeper, page 4-3
- Using the Cisco ATA Without an H.323 Gatekeeper, page 4-6
- Setting the Audio Codecs, page 4-7

Required Parameters

You need to supply values for the required H.323 parameters shown in Table 4-1. The Parameter column provides the name of the parameter and a cross reference which provides a more-detailed description of the parameter.



Note

See *Chapter 5, “Parameters and Defaults,”* for information about additional Cisco ATA parameters.

Table 4-1 Required H.323 Parameters and Defaults

Parameter	Value Type	Description	Voice Menu Access Code	Default
UID0, page 5-16	Alphanumeric string	User ID for the Phone 1 port.	3	0
UID1, page 5-17	Alphanumeric string	User ID for Phone 2 port.	13	0
PWD0, page 5-16	Alphanumeric string	Password for the Phone 1 port.	4	0
PWD1, page 5-18	Alphanumeric string	Password for the Phone 2 port.	14	0
LoginID0, page 5-18	Alphanumeric string	Login ID for the Phone 1 port. If this value is 0, the UID0 parameter is used for authentication.	46	0
LoginID1, page 5-19	Alphanumeric string	Login ID for the Phone 2 port. If this value is 0, the UID1 parameter is used for authentication.	47	0
GkOrProxy, page 5-13	Alphanumeric string	IP address of the H.323 gatekeeper.	5	0
UseLoginID, page 5-19	Boolean	Enables the Cisco ATA to use its H.323 ID for authenticated login.	93	0
AltGk, page 5-14	Alphanumeric string	IP address of the statically defined alternate gatekeeper.	6	0
AltGkTimeOut, page 5-15	Integer	The timeout value, in seconds, for an alternate gatekeeper. The allowed range is 30 to 4294967295 seconds.	251	0
GkTimeToLive, page 5-14	Integer	The “time to live” value that is used when the Cisco ATA registers with the H.323 gatekeeper. The registration is valid until the configured time expires.	250	0
GkId, page 5-14	Alphanumeric string	Identifier for the primary H.323 gatekeeper.	91	.

Setting Up User IDs for the Cisco ATA

Each Cisco ATA can support two FXS ports. You can assign a user ID, which is usually an E.164 phone number, to each port. Use the Cisco ATA parameter `UID0` to configure an ID for the **Phone 1** port, and use the `UID1` parameter for the user ID of the **Phone 2** port.

Related Configuration Parameters

- `UID0`, page 5-16
- `UID1`, page 5-17

Using the Cisco ATA with an H.323 Gatekeeper

The Cisco ATA can function with an H.323 gatekeeper to enable Cisco ATA registration, admission, and use of directory services on an H.323 network. To use the Cisco ATA with a primary H.323 gatekeeper, you need to configure the `GkOrProxy` parameter with the IP address assigned to the primary H.323 gatekeeper. Optionally, you can specify the primary gatekeeper identifier using the `GkId` parameter if this identifier is required for the Cisco ATA to successfully register with the H.323 network.

This section contains the following topics:

- Choosing Cisco ATA Registration Mode with an H.323 Gatekeeper, page 4-3
- Setting Up Gatekeeper Time-To-Live Value, page 4-4
- Setting Up an Alternate H.323 Gatekeeper, page 4-4
- Establishing Authentication with Cisco H.323 Gatekeeper, page 4-5

Related Configuration Parameters

- `GkOrProxy`, page 5-13
- `GkId`, page 5-14

Choosing Cisco ATA Registration Mode with an H.323 Gatekeeper

The Cisco ATA can register with an H.323 gatekeeper in one of two modes:

- Single registration—Both Cisco ATA FXS ports register at the same time with the H.323 gatekeeper. This reduces gatekeeper registration traffic by 50 percent when both ports are enabled.
- Dual registration—Each FXS port registers separately with the H.323 gatekeeper.

To configure single-mode registration, you need to set the `UseLoginID` parameter to **1**, and then configure the `LoginID1` and `LoginID2` parameters with identical values. The `LoginID1` and `LoginID2` parameters are used for the H.323 ID, whereas the `UID0` and `UID1` parameter values are used as E.164 phone numbers.

If LoginID1 and LoginID2 are not used or are not set to identical values, the Cisco ATA uses dual-registration mode.

Related Parameters

- LoginID0, page 5-18
- LoginID1, page 5-19
- UID0, page 5-16
- UID1, page 5-17

Setting Up Gatekeeper Time-To-Live Value

You can specify the valid duration of the H.323 gatekeeper registration, in seconds, by using the GkTimeToLive parameter.

Related Configuration Parameter

GkTimeToLive, page 5-14

Setting Up an Alternate H.323 Gatekeeper

To provide redundancy in systems that use an H.323 gatekeeper, the Cisco ATA allows you to either statically configure an alternate H.323 gatekeeper or dynamically assign an H.323 gatekeeper.

To enable the static alternate gatekeeper feature, you need to configure the AltGk parameter with the IP address assigned to the alternate H.323 gatekeeper. To enable the Cisco ATA to perform full gatekeeper registration when it switches to a statically configured alternate H.323 gatekeeper, configure Bit 3 of the ConnectMode parameter to the value of **1**.

To enable the dynamic alternate gatekeeper feature, you need to configure the primary H.323 gatekeeper so that the list of alternate gatekeepers is included in the H.225 RAS messages that the H.323 gatekeeper sends to the Cisco ATA. The Cisco ATA can accept as many as four dynamic alternate gatekeepers configured in the H.225 RAS messages. (The Cisco ATA supports the alternate gatekeeper list in GCF/GRJ, ACF/ARJ, RCF/RRJ, and DRJ RAS messages.)

Dynamic alternate gatekeepers and static alternate gatekeepers can co-exist. When the Cisco ATA receives an alternate gatekeeper list in an H.225 RAS message, the static alternate gatekeeper is merged with the dynamic alternate gatekeepers. The static alternate gatekeeper is kept and given the lowest priority.

You can configure the AltGkTimeout parameter to specify the number of seconds the Cisco ATA should wait before it automatically switches back to the primary H.323 gatekeeper after being moved to an alternate gatekeeper. By default, the switch-back procedure is disabled (the AltGkTimeout parameter value is set to 0).

Related Configuration Parameters

- AltGk, page 5-14
- AltGkTimeOut, page 5-15
- ConnectMode, page 5-32

Establishing Authentication with Cisco H.323 Gatekeeper

You can configure the Cisco ATA to establish authentication with a Cisco H.323 Gatekeeper. The Cisco ATA supports two authentication methods:

- Cisco registration level-security
- Cisco admission-level security (per-call basis)

To configure either authentication method, use the following procedure:

Procedure

-
- Step 1** Set the UseLoginID parameter to **1**. This setting indicates that the LoginID0 and LoginID1 fields will be used for Cisco ATA H.323 registration.
 - Step 2** Set the UID0 and UID1 parameters to the E.164 phone numbers that are assigned to the FXS ports on the Cisco ATA.
 - Step 3** Set the LoginID0 and LoginID1 parameters to the H.323 ID. The H.323 ID is used when the Cisco ATA registers with the H.323 gatekeeper. This ID is also used as the account ID for the RADIUS server.
 - Step 4** Set the PWD0 and PWD1 parameters to the passwords for the **Phone 1** and **Phone 2** FXS ports (the passwords in the RADIUS server), respectively.
 - Step 5** Set the NTPIP and AltNTPIP parameters to the IP addresses of the NTP servers in your network.
 - Step 6** Select the authentication method using the AutMethod parameter (**0** indicates no authentication; **1** indicates the Cisco registration level security method; **2** indicates the Cisco admission level security method).



Note The authentication methods are Cisco Proprietary H.235 implementations, which use the Cisco access/clear token structure rather than the VocalTec crypto token structure.

Related Configuration Parameters

- UseLoginID, page 5-19
- AutMethod, page 5-20
- LoginID0, page 5-18
- LoginID1, page 5-19
- UID0, page 5-16
- UID1, page 5-17
- PWD0, page 5-16
- PWD1, page 5-18
- NTPIP, page 5-10
- AltNTPIP, page 5-11

Using the Cisco ATA Without an H.323 Gatekeeper

You can use the Cisco ATA without using an H.323 gatekeeper, as this section describes with the following topics:

- Using the Cisco ATA With an H.323 Gateway but Without an H.323 Gatekeeper, page 4-6
- Using Multiple Cisco ATAs Without an H.323 Gatekeeper, page 4-6

Using the Cisco ATA With an H.323 Gateway but Without an H.323 Gatekeeper

You can use a Cisco ATA with an H.323 network that does not contain an H.323 gatekeeper. In this scenario, all calls initiated from the Cisco ATA are directed to a specified H.323 gateway. To specify this H.323 gateway, you configure its IP address using the Gateway parameter, and you disable the H.323 gatekeeper feature by setting the GkorProxy parameter to 0.



Note

For all calls sent from the H.323 gateway to the Cisco ATA, the E.164 number assigned to each of the Cisco ATA FXS ports must be included in the H.225 Setup message, either in the DestinationAddress field or the Q.931 CalledPartyNumber field. The Cisco ATA will reject the call if it cannot find its E.164 number in the H.255 Setup message.

Related Configuration Parameters

- Gateway, page 5-20
- GkOrProxy, page 5-13

Using Multiple Cisco ATAs Without an H.323 Gatekeeper

You can make calls from one Cisco ATA to another Cisco ATA in an H.323 network that does not contain an H.323 gatekeeper.

For one Cisco ATA to access a specific FXS port on another Cisco ATA, you use an IP dialing procedure. The Cisco ATA originating the call must have the following information about the destination Cisco ATA:

- E.164 phone number of the destination FXS port
- IP address of the destination Cisco ATA

To enable the IP dialing procedure, you need to set the IPDialPlan parameter to **1** to instruct the Cisco ATA to look for the destination IP address in the dialed digits.

Example

Cisco ATA X is going to initiate a call to Cisco ATA Y (with the following pertinent information):

- IP address of Cisco ATA Y—192.168.2.112.
- E.164 phone number for the **Phone 1** port of Cisco ATA Y—1:5556666
- E.164 phone number for the **Phone 2** port of Cisco ATA Y—2:5558888

To call the **Phone 1** port on Cisco ATA *Y*, you would dial **5556666**192*168*2*112#**.

To call the **Phone 2** port on Cisco ATA *Y*, you would dial **5558888**192*168*2*112#**.

Related Configuration Parameters

- IPDialPlan, page 5-60
- DialPlan, page 5-52

Setting the Audio Codecs

You can configure the following codec-related settings:

- Low-bit-rate codec—When operating with a low-bit-rate codec, the Cisco ATA can support either two G.723.1 connections or one G.729 connection. You must statically configure the selection of G.723.1 or G.729 by using the LBRCodec parameter.

When G.723.1 is the low-bit-rate codec, each FXS port is allocated one G.723.1 connection. When G.729 is used, only one FXS port can use G.729. The G.729 resource is allocated in a dynamic manner. When a call begins, the FXS port requests and takes an available G.729 resource. The Cisco ATA releases this resource when the call is completed.

Use Bit 1 of the AudioMode parameter to disable and enable the use of the low-bit-rate codec.

Related Configuration Parameters

- LBRCodec, page 5-23
- AudioMode, page 5-24
- Voice codec—You can configure the preferred voice codec for transmitting and receiving voice data by using the TxCodec and RxCodec parameters, respectively. Cisco recommends that you configure the same voice codec for TxCodec and RxCodec.

Related Configuration Parameters

- TxCodec, page 5-22
- RxCodec, page 5-22
- Silence suppression—You can configure silence suppression for G.711/G.723.1/G.729 by using the ConnectMode parameter (Bit 0 for the **Phone 1** port and Bit 16 for the **Phone 2** port).

Related Configuration Parameter

ConnectMode, page 5-32

Additional H.323 Services

This section describes additional H.323 services and, where applicable, provides configuration information and cross references to the parameters for configuring these services, described in alphabetical order:

- Configurable Reboot of Cisco ATA, page 4-8
- Configuring Audio Packet Settings, page 4-8
- Configuring Billable Features, page 4-8
- Configuring the Call Waiting Permanent Default Setting, page 4-9
- Configuring the Cisco ATA Refresh Interval, page 4-9

- Configuring Hook Flash Timing, page 4-9
- Configuring the Mixing of Call Waiting Tone and Audio, page 4-9
- Configuring Network Ringback Tone, page 4-10
- Configuring Reverse Audio Cut-Through Behavior, page 4-10
- Configuring Supplementary Service Behavior and Parameters, page 4-10
- Debugging Diagnostics, page 4-10
- Hardware Information Display, page 4-10
- Network Timing, page 4-11
- Polarity Settings, page 4-11
- Progress Tones, page 4-11
- Selecting DTMF and Hookflash Transmission Methods, page 4-11
- Selecting H.323 Connection and H.245 Transmission Methods, page 4-12
- Setting Dial Plans, page 4-12

Configurable Reboot of Cisco ATA

The Cisco ATA continuously monitors its Ethernet connection to the switch or hub. If this connection is broken, the Cisco ATA starts an internal timer that runs until a configurable timeout period expires. Once the timeout value is reached, the Cisco ATA automatically reboots. This timeout value is configured by using the FeatureTimer2 configuration parameter. For more information, see the “FeatureTimer2” section on page 5-31.

Configuring Audio Packet Settings

Table 4-2 lists configurable audio-packet settings and their related configuration parameters.

Table 4-2 Audio Packet Settings and Related Parameters

Feature	Related Parameter
Base port for receiving RTP packets	MediaPort, page 5-21
Class of Service (CoS) bit specification for signaling IP packets	VLANSetting, page 5-12
RTP-packet size	NumTxFrames, page 5-25
Type of Service (ToS) bit specification for audio and signaling IP packets	TOS, page 5-26

Configuring Billable Features

You can customize specific features on a subscription basis by changing the values of specific bits in several different parameters. Table 4-3 contains a list of billable features and their related parameters:

Table 4-3 Billable Features and Related Parameters

Feature	Related Parameters
Call Conferencing	PaidFeatures, page 5-28, CallFeatures, page 5-27
Call Waiting	PaidFeatures, page 5-28, CallFeatures, page 5-27, SigTimer, page 5-31
Caller ID	PaidFeatures, page 5-28, CallFeatures, page 5-27, CallerIdMethod, page 5-38
Polarity	Polarity, page 5-39

**Note**

CallWaitCallerID is an obsolete parameter. Do not use it.

Configuring the Call Waiting Permanent Default Setting

This feature allows you to specify the default call-waiting setting for every call on a permanent basis by means of the service activation and deactivation codes.

Related Parameter

ConnectMode, page 5-32—Bit 23

Configuring the Cisco ATA Refresh Interval

When the value specified in the CfgInterval parameter is reached, the Cisco ATA attempts to refresh its configuration file from the TFTP server. Set the CfgInterval parameter to an interval value (in seconds) for refreshing the Cisco ATA configuration file. Cisco recommends that the interval be semi-random to prevent many simultaneous contacts with the TFTP server. For more information, see the “CfgInterval” section on page 5-6.

When the Cisco ATA contacts the TFTP server, it also checks to see if an upgrade signaling image has been placed on the TFTP server. If such an image exists, the Cisco ATA will download this image.

Configuring Hook Flash Timing

This feature provides the ability to adjust the hook-flash timing to meet local requirements.

Related Parameter

SigTimer, page 5-31—Bits 26 and 27 are for configuring the minimum on-hook time required for a hook flash event, and bits 28 through 31 are for configuring maximum on-hook time.

Configuring the Mixing of Call Waiting Tone and Audio

This feature allows the call-waiting tone to be mixed with the audio in an active call. This mixing causes the call-waiting tone to sound without a pause in the audio.

Related Parameter

ConnectMode, page 5-32

Configuring Network Ringback Tone

You can configure the Cisco ATA to send a ringback tone to a caller by using bit 19 of the ConnectMode parameter.

Related Configuration Parameter

ConnectMode, page 5-32

Configuring Reverse Audio Cut-Through Behavior

You can configure the reverse audio cut-through behavior of the Cisco ATA by using Bit 5 of the ConnectMode parameter.

Related Configuration Parameter

ConnectMode, page 5-32

Configuring Supplementary Service Behavior and Parameters

Service providers can offer many supplementary services, which can be activated, configured, or deactivated in more than one way.

The behavior and activation/deactivation of call supplementary services can be different from one country to another. You can use the CallCmd parameter to define the behavior and the activation/deactivation access code for the supplementary services that the Cisco ATA supports.

Related Configuration Parameter

CallCmd, page 5-29

Debugging Diagnostics

You can use the following parameter to troubleshoot operation issues:

- NPrintf, page 5-61—Use this parameter to specify the IP address and port where debug information is sent.

Hardware Information Display

Cisco ATA hardware information is displayed in the lower-left corner of the Cisco ATA Web configuration page.

Network Timing

You can fine-tune your network timing with the following parameters:

- TimeZone, page 5-36—Use for time-stamping incoming calls (offset from Greenwich Mean Time) with local time.
- NTPIP, page 5-10—Use for configuring the IP address of the Network Time Protocol server. NTP is a protocol built on top of TCP that ensures accurate local time-keeping with reference to radio and atomic clocks located on the Internet.
- AltNTPIP, page 5-11—Use to configure an alternate NTP server IP address.
- ConnectMode, page 5-32—Used to control the connection mode of the H.323 protocol.

Polarity Settings

You can control line polarity of the Cisco ATA FXS ports when a call is connected or disconnected by configuring the Polarity bitmap parameter (see the “Polarity” section on page 5-39).

Progress Tones

Values for the following parameters (all defined in the “Tone Configuration Parameters” section on page 5-41) must be determined based on the country in which the Cisco ATA is located:

- DialTone
- BusyTone
- ReorderTone
- RingBackTone
- CallWaitTone
- AlertTone

Selecting DTMF and Hookflash Transmission Methods

The Cisco ATA is designed to use H.245 messages to relay DTMF and hookflash events. Both the H.245 alphanumeric IE method and the H.245 signal IE method are supported for transporting DTMF events. The H.245 signal IE method has higher precedence if the far end also supports this method.

Use bits 4-5 (**Phone 1** port) and 20-21 (**Phone 2** port) of the AudioMode parameter to configure the DTMF transmission method.

Use bit 6-7 (**Phone 1** port) and 22-23 (**Phone 2** port) of the AudioMode parameter to configure the hookflash transmission method.

Related Configuration Parameter

AudioMode, page 5-24

Selecting H.323 Connection and H.245 Transmission Methods

You can configure the H.323 connection method and the H.245 transmission method. Use Bit 0 of the ConnectMode parameter to select either the slow-start procedure or the fast-start procedure for the H.323 connection. Use Bit 1 of the ConnectMode parameter to select either a separate H.245 connection or H.245 tunneling for H.245-message transmission.

Related Configuration Parameter

ConnectMode, page 5-32—Bits 0 and 1

Setting Dial Plans

You can set specific dial plan rules and timeout values. Many of these values are determined on a country-by-country basis.

Related Parameter

DialPlan, page 5-52

Complete Reference Table of all Cisco ATA H.323 Services

Table 4-4 is a reference table that lists all configurable features for the Cisco ATA (using H.323), and includes links to the detailed descriptions of the parameters used for configuring these features.

Table 4-4 Configurable Features and Related Parameters

Configurable Features	Related Parameters
Audio Media Features <ul style="list-style-type: none"> • Low bit-rate codec selection (G.723.1, G.729) • Silence suppression • RTP media port • Preferred audio codec for transmitting and receiving voice data • RTP packet size 	Audio Media Parameters <ul style="list-style-type: none"> • LBRCCodec, page 5-23 • AudioMode, page 5-24 • MediaPort, page 5-21 • TxCodec, page 5-22, RxCodec, page 5-22 • NumTxFrames, page 5-25
Audio cut-through configuration	ConnectMode, page 5-32
Caller ID format	CallerIdMethod, page 5-38
DTMF and hookflash transmission methods	AudioMode, page 5-24
Debug and Diagnosis	NPrintf, page 5-61
Dial plans	DialPlan, page 5-52
Fax Services Features <ul style="list-style-type: none"> • Fax services mode selection • Named Signaling Event (NSE) payload type for fax pass-through 	Fax Services Parameters <ul style="list-style-type: none"> • AudioMode, page 5-24, ConnectMode, page 5-32 • ConnectMode, page 5-32

Table 4-4 Configurable Features and Related Parameters (continued)

Configurable Features	Related Parameters
H.323 connection method and H.245 transmission method	ConnectMode, page 5-32
H.323 endpoint configuration: <ul style="list-style-type: none"> E.164 phone number configuration H.323 gatekeeper configuration Authentication Gateway configuration IP dialing configuration 	H.323 endpoint parameters: <ul style="list-style-type: none"> UID0, page 5-16, UID1, page 5-17 GkOrProxy, page 5-13, GkId, page 5-14, GkTimeToLive, page 5-14, AltGk, page 5-14, AltGkTimeOut, page 5-15, ConnectMode, page 5-32 AuthMethod, page 5-20, UseLoginID, page 5-19, LoginID0, page 5-18, LoginID1, page 5-19, UID0, page 5-16, UID1, page 5-17, PWD0, page 5-16, PWD1, page 5-18, NTPIP, page 5-10, AltNTPIP, page 5-11 Gateway, page 5-20, GkOrProxy, page 5-13 IPDialPlan, page 5-60, DialPlan, page 5-52
Hook-flash detection timing configuration	SigTimer, page 5-31
Warmline/hotline support (PLAR feature)	'H' Rule to Support Hot/Warm Line, page 5-54
Network ringback tone feature	ConnectMode, page 5-32
Network-related features: <ul style="list-style-type: none"> Cisco Discovery Protocol (CDP)—on/off DHCP configuration DNS configuration Static IP configuration VLAN configuration 	Network-related Parameters: <ul style="list-style-type: none"> OpFlags, page 5-34 DHCP, page 5-8, OpFlags, page 5-34 DNS1IP, page 5-11, DNS2IP, page 5-12 StaticIp, page 5-9, StaticRoute, page 5-9, StaticNetMask, page 5-10 OpFlags, page 5-34, VLANSetting, page 5-12
Network timing configuration	TimeZone, page 5-36, NTPIP, page 5-10, AltNTPIP, page 5-11

Table 4-4 Configurable Features and Related Parameters (continued)

Configurable Features	Related Parameters
User Interface and TFTP Features: <ul style="list-style-type: none"> • User interface password • TFTP Configuration • TFTP Encryption key • TFTP image upgrade • TFTP configuration file retrieval interval • HTTP refresh/reset access—disable/enable • Web configuration—enable/disable 	User Interface and TFTP Parameters: <ul style="list-style-type: none"> • UIPassword, page 5-3 • UseTFTP, page 5-4, TftpURL, page 5-5, OpFlags, page 5-34 • EncryptKey, page 5-6, EncryptKeyEx, page 5-7 • upgradecode (see the “Upgrading the Signaling Image from a TFTP Server” section on page 8-1) • CfgInterval, page 5-6 • OpFlags, page 5-34 • OpFlags, page 5-34
Packet Precedence Features: <ul style="list-style-type: none"> • Type of Service (ToS) configuration • 802.1P Class of Service (Cos) Bit configuration 	Packet Precedence Parameters: <ul style="list-style-type: none"> • TOS, page 5-26 • VLANSetting, page 5-12
Polarity settings for FXS ports	Polarity, page 5-39
Ring-cadence format	RingOnOffTime, page 5-51
Supplementary services configuration	CallCmd, page 5-29, CallFeatures, page 5-27, PaidFeatures, page 5-28
Tone format: BusyTone, CallWaitTone, ConfirmTone, DialTone, ReorderTone, and Ring-BackTone parameters	Tone Configuration Parameters, page 5-41, SigTimer, page 5-31



Parameters and Defaults

This section provides information on the parameters and defaults that you can use to create your own Cisco ATA configuration file. This section also includes the voice configuration menu code for each parameter that has such a code.

Parameters are divided into categories based on their functionality. The following categories of parameters are covered in this section:

- User Interface (UI) Security Parameter, page 5-3
- Parameters for Configuration Method and Encryption, page 5-4
- Network Configuration Parameters, page 5-8
- H.323 Parameters, page 5-13
- Audio Configuration Parameters, page 5-21
- Operational Parameters, page 5-26
- Telephone Configuration Parameters, page 5-37
- Tone Configuration Parameters, page 5-41
- Dial Plan Parameters, page 5-52
- Diagnostic Parameters, page 5-60
- CFGID—Version Parameter for Cisco ATA Configuration File, page 5-63

The following list contains general configuration information:

- Your configuration file must begin with **#txt**.
- The Cisco ATA uses the following parameter types:
 - Alphanumeric string
 - Array of short integers
 - Boolean (1 or 0)
 - Bitmap value—unsigned hexadecimal integer (for specifying bits in a 32-bit integer)



Note Bits are numbered from right to left, starting with bit 0.



Note A tool called bitaid.exe is bundled with your Cisco ATA software. You can use this tool to help you configure values of Cisco ATA bitmap parameters. The tool prompts you for the necessary information.

- Extended IP address—IP address followed by port number (for example, 192.168.2.170.9001)
- IP address (e.g. 192.168.2.170)
- Integer (32-bit integer)
- Numeric digit string



Note The term *Cisco ATA* is used throughout this manual to refer to both the Cisco ATA 186 and the Cisco ATA 188, unless differences between the Cisco ATA 186 and Cisco ATA 188 are explicitly stated.



Note This section contains recommended values for the United States and other countries as configuration examples for certain parameters. For detailed recommendations of tone-parameter values by country, see Appendix E, “Recommended Cisco ATA Tone Parameter Values by Country.”

Configuration Text File Template

This is a listing of the h323_example.txt text file, without its annotations, that comes bundled with the Cisco ATA software.

You can make a copy of this file and use it as a template for creating your own default configuration file or Cisco ATA-specific configuration file. For instructions on how to create these configuration files, see the “Creating Unique and Common Cisco ATA Configuration Files” section on page 3-9.

The h323_example.txt file contains all the Cisco ATA default values. The sections that follow this listing describe all the parameters in this file.

```
#txt
UIPassword:0
UseTftp:1
TftpURL:0
cfgInterval:3600
EncryptKey:0
EncryptKeyEx:0
upgradecode:0,0x301,0x0400,0x0200,0.0.0.0,69,0,none
upgradelang:0,0x301,0x0400,0x0200,0.0.0.0,69,0,none
Dhcp:1
StaticIp:0
StaticRoute:0
StaticNetMask:0
NTPIP:0.0.0.0
AltNTPIP:0.0.0.0
DNS1IP:0.0.0.0
DNS2IP:0.0.0.0
VLANSetting:0x0000002b
GkOrProxy:0
GkId:.
GkTimeToLive:0
AltGk:0
```

```

AltGkTimeOut:0
UID0:0
UID1:0
UseLoginID:0
LoginID0:0
LoginID1:0
PWD0:0
PWD1:0
AutMethod:0x00000000
GateWay:0
MediaPort:16384
RxCodec:1
TxCodec:1
LBRCCodec:0
AudioMode:0x00150015
NumTxFrames:2
TOS:0x0000A8B8
CallFeatures:0xffffffff
PaidFeatures:0xffffffff
CallCmd:Af;AH;BS;NA;CS;NA;Df;EB;Ff;EP;Kf;EFh;HH;Jf;AFh;HQ;I*67;gA*82;fA#90v#;OI;H#72v#;
bA#74v#;cA#75v#;dA#73;eA*67;gA*82;fA*70;iA*69;DA*99;xA;Uh;GQ;
FeatureTimer:0x00000000
FeatureTimer2:0x0000001e
SigTimer:0x01418564
ConnectMode:0x00060400
OpFlags:0x00000002
TimeZone:17
CallerIdMethod:0x00019e60
Polarity: 0
FXSInputLevel:-1
FXSOutputLevel:-4
DialTone:2,31538,30831,1380,1740,1,0,0,1000
BusyTone:2,30467,28959,1191,1513,0,4000,4000,0
ReorderTone:2,30467,28959,1191,1513,0,2000,2000,0
RingBackTone:2,30831,30467,1943,2111,0,16000,32000,0
CallWaitTone:1,30831,0,5493,0,0,2400,2400,4800
AlertTone:1,30467,0,5970,0,0,480,480,1920
RingOnOffTime:2,4,25
DialPlan:*St4-|#St4-|911|1>#t8.r9t2-|0>#t811.rat4-|^1t4>#.-
IPDialPlan: 1
NPrintf:0
TraceFlags:0x00000000
SyslogIP:0.0.0.0.514
SyslogCtrl:0x00000000

```

The sections that follow describe these parameters.

User Interface (UI) Security Parameter

This section contains only one parameter—UIPassword.

UIPassword

Description

This parameter controls access to web page or voice configuration menu interface. To set a password, enter a value other than zero. To have the user prompted for this password when attempting to perform a factory reset or upgrade using the voice configuration menu, see the “OpFlags” section on page 5-34.

To clear a password, change the value to 0.

You cannot recover a forgotten password unless you reset the entire configuration of the Cisco ATA (see the “Resetting the Cisco ATA to Factory Default Values” section on page 3-23).

**Note**

When UIPassword contains letters, you cannot enter the password from the telephone keypad.

Value Type

Alphanumeric string

Range

Maximum nine characters

Default

0

Voice Configuration Menu Access Code

7387277

Related Parameter

OpFlags, page 5-34—Bit 7

Parameters for Configuration Method and Encryption

This section describes parameters for instructing the Cisco ATA about how to locate its TFTP server and how to encrypt its configuration file:

- UseTFTP, page 5-4
- TftpURL, page 5-5
- CfgInterval, page 5-6
- EncryptKey, page 5-6
- EncryptKeyEx, page 5-7

UseTFTP

Settings

1—Use the TFTP server for Cisco ATA configuration.

0—Do not use the TFTP server for Cisco ATA configuration.

Value Type

Boolean

Range

0 or 1

Default

1

Voice Configuration Menu Access Code

305

Related Parameters

- TftpURL, page 5-5
- EncryptKey, page 5-6
- EncryptKeyEx, page 5-7
- OpFlags, page 5-34—bits 0 and 3
- CfgInterval, page 5-6

TftpURL

Description

Use this parameter to specify the IP address or URL of the TFTP server. This string is needed if the DHCP server does not provide the TFTP server IP address. When the TftpURL parameter is set to a non-zero value, this parameter has priority over the TFTP server IP address supplied by the DHCP server.

Optionally, you can include the path prefix to the TFTP file to download.

For example, if the TFTP server IP address is 192.168.2.170 or www.cisco.com, and the path to download the TFTP file is in /ata186, you can specify the URL as 192.168.2.170/ata186 or www.cisco.com/ata186.

**Note**

From the voice configuration menu, you can only enter the IP address; from the web server, you can enter the actual URL.

Value Type

Alphanumeric string

Range

Maximum number of characters: 31

Default

0

Voice Configuration Menu Access Code

905

Related Parameters

- UseTFTP, page 5-4
- CfgInterval, page 5-6

CfgInterval

Description

Use this parameter to specify the number of seconds between each configuration update. The Cisco ATA will also upgrade its signaling image if it detects that the TFTP server contains an upgraded image.

For example, when using TFTP for configuration, the Cisco ATA contacts TFTP each time the interval expires to get its configuration file.

You can set CfgInterval to a random value to achieve random contact intervals from the Cisco ATA to the TFTP server.

Value Type

Decimal

Range

60 to 4294967295

Default

3600

Voice Configuration Menu Access Code

80002

Related Parameters

- UseTFTP, page 5-4
- TftpURL, page 5-5

EncryptKey

Description

This parameter specifies the encryption key that is used to encrypt the Cisco ATA configuration file on the TFTP server.

The cfgfmt tool, which is used to create a Cisco ATA binary configuration file (see the “Using Encryption With the cfgfmt Tool” section on page 3-12), automatically encrypts the binary file when the EncryptKey parameter has a value other than 0. The cfgfmt tool uses the rc4 encryption algorithm.

If this parameter value is set to 0, the Cisco ATA configuration file on the TFTP server is not encrypted.



Note

Cisco recommends using the stronger Cisco ATA encryption method, which requires the use of the EncryptKeyEx parameter. For more information, see the “EncryptKeyEx” section on page 5-7.

For examples on how to upgrade from the EncryptKey parameter to the stronger encryption method that uses the EncryptKeyEx parameter, see the “Examples of Upgrading to Stronger Encryption Key” section on page 3-15.

Value Type

Hexadecimal string

Range

Maximum number of characters: 8

Default

0

Voice Configuration Menu Access Code

320

Related Parameters

- UseTFTP, page 5-4
- TftpURL, page 5-5
- EncryptKeyEx, page 5-7

EncryptKeyEx

Description

This parameter specifies an encryption key that is stronger than the key specified with the EncryptKey parameter. This stronger key is used to encrypt the Cisco ATA configuration file on the TFTP server.

**Note**

Cisco recommends using the EncryptKeyEx parameter instead of the EncryptKey parameter for the strongest possible encryption of the Cisco ATA configuration file.

When the EncryptKeyEx parameter is set to a non-zero value, the Cisco ATA uses this value as the encryption key and ignores any value that has been set for the EncryptKey parameter. The cfgfmt tool, which is used to create a Cisco ATA binary configuration file (see the “Using Encryption With the cfgfmt Tool” section on page 3-12), automatically encrypts the binary file using the stronger rc4 encryption algorithm.

When EncryptKeyEx is used for encryption, the Cisco ATA searches for the configuration file with the format `ata<macaddress>.x` on the TFTP server.

If the value of the EncryptKeyEx parameter is 0, then the Cisco ATA uses the value of the EncryptKey parameter for encryption.

**Note**

The cfgfmt tool (version 2.3) program generate an `ata<macaddress>.x` file in addition to an `ata<macaddress>` file if the EncryptKeyEx parameter is specified. You should place both such configuration files on the TFTP server.

For examples on how to upgrade from the EncryptKey parameter to the stronger encryption method that uses the EncryptKeyEx parameter, see the “Examples of Upgrading to Stronger Encryption Key” section on page 3-15.

Value Type

Hexadecimal string of the form:

Rc4PasswdInHex/macInHex_12

- rc4KeyInHex_n is a hexadecimal string of one to 64 characters.
- /macInHex_12 is the optional extension consisting of a forward slash (/) followed by the six-byte MAC address of the Cisco ATA to which the configuration file will be downloaded.

Range

Maximum number of characters: 64

Default

0

Voice Configuration Menu Access Code

Not applicable for this parameter.

Related Parameters

- UseTFTP, page 5-4
- TftpURL, page 5-5
- EncryptKey, page 5-6

Network Configuration Parameters

This section includes the parameters for enabling or disabling the use of a DHCP server to obtain IP address information, and parameters that you need to statically configure if you disable DHCP:

- DHCP, page 5-8
- StaticIp, page 5-9
- StaticRoute, page 5-9
- StaticNetMask, page 5-10
- NTPIP, page 5-10
- AltNTPIP, page 5-11
- DNS1IP, page 5-11
- DNS2IP, page 5-12
- VLANSetting, page 5-12

DHCP

Description

A DHCP server can be used to automatically set the Cisco ATA IP address, the network route IP address, the subnet mask, DNS, NTP, TFTP, and other parameters.

- 1—Enable DHCP
- 0—Disable DHCP

Value Type

Boolean

Range

0 or 1

Default

1

Voice Configuration Menu Access Code

20

Related Parameters

- StaticIp, page 5-9
- StaticRoute, page 5-9
- StaticNetMask, page 5-10
- OpFlags, page 5-34—Bits 3 and 11

StaticIp

Description

Use this parameter to statically assign the Cisco ATA IP address if the DHCP parameter is set to 0.

Value Type

IP address

Default

0.0.0.0

Voice Configuration Menu Access Code

1

Related Parameters

- DHCP, page 5-8
- StaticRoute, page 5-9
- StaticNetMask, page 5-10

StaticRoute

Description

Use this parameter to statically assign the Cisco ATA route if the DHCP parameter is set to 0.

Value Type

IP address

Default

0.0.0.0

Voice Configuration Menu Access Code

2

Related Parameters

- DHCP, page 5-8
- StaticIp, page 5-9
- StaticNetMask, page 5-10

StaticNetMask

Description

Use this parameter to statically assign the Cisco ATA subnet mask if the DHCP parameter is set to 0

Value Type

IP address

Default

255.255.255.0

Voice Configuration Menu Access Code

10

Related Parameters

- DHCP, page 5-8
- StaticIp, page 5-9
- StaticRoute, page 5-9

NTPIP

Description

This parameter is the NTP IP address, required if DHCP server does not provide one.

The Cisco ATA requires an NTP Server from which to obtain Coordinated Universal Time (UTC) to time-stamp incoming calls (H.323 and SIP) to drive an external Caller-ID device.

DHCP may also supply a NTP server. If NTPIP is specified, it overwrites the value supplied by DHCP. NTPIP is ignored if its value is 0 or 0.0.0.0.

The user *must not* specify a port parameter. The Cisco ATA uses the default NTP port only.

Value Type

IP address

Default

0.0.0.0

Voice Configuration Menu Access Code

141

Related Parameters

- AltNTPIP, page 5-11
- TimeZone, page 5-36

AltNTPIP

Description

This parameter is the alternate NTP IP address, if you want redundancy. You can set this parameter to 0 or point to the same NTPIP if only one NTP server exists.

Value Type

IP address

Default

0.0.0.0

Voice Configuration Menu Access Code

142

Related Parameters

- NTPIP, page 5-10
- TimeZone, page 5-36

DNS1IP

Description

This parameter is for setting the primary domain name server (DNS) IP address, if the DHCP server does not provide one. If DHCP provides DNS1IP (and if it is non-zero), this parameter overwrites the DHCP-supplied value. You *cannot* specify a port parameter. The Cisco ATA uses the default DNS port only.

Value Type

IP address

Default

0.0.0.0

Voice Configuration Menu Access Code

916

DNS2IP

Description

This parameter is for setting the secondary domain name server (DNS) IP address, if the DHCP server does not provide one. If DHCP provides DNS2IP (if it is non-zero), this parameter overwrites the DHCP-supplied value. You cannot specify a port parameter. The Cisco ATA uses the default DNS port only.

Value Type

IP address

Default

0.0.0.0

Voice Configuration Menu Access Code

917

VLANSetting

Description

This parameter is for firmware version 2.15 and above.

Bitmap definitions are as follows for the VLANSetting parameter:

- Bits 0-2—Specify VLAN Class of Service (CoS) bit value (802.1P priority) for signaling IP packets.
- Bits 3-5—Specify VLAN CoS bit value (802.1P priority) for voice IP packets.
- Bits 6-17—Reserved.
- Bits 18-29—User-specified 802.1Q VLAN ID.
- Bits 30-31—Reserved.

Value Type

Bitmap

Default

0x0000002b

Voice Configuration Menu Access Code

324

Related Parameter

OpFlags, page 5-34

H.323 Parameters

This sections describes the following parameters, which include H.323 Gatekeeper configuration parameters:

- GkOrProxy, page 5-13
- GkId, page 5-14
- GkTimeToLive, page 5-14
- AltGk, page 5-14
- AltGkTimeOut, page 5-15
- UID0, page 5-16
- PWD0, page 5-16
- UID1, page 5-17
- PWD1, page 5-18
- LoginID0, page 5-18
- LoginID1, page 5-19
- UseLoginID, page 5-19
- AutMethod, page 5-20
- Gateway, page 5-20

GkOrProxy

Description

This parameter is the IP address of the primary H.323 gatekeeper.

Value Type

Alphanumeric string

Range

Maximum number of characters: 31

Default

0—Disables gatekeeper-routed calls.

Voice Configuration Menu Access Code

5

Related Parameters

- AltGk, page 5-14
- AltGkTimeOut, page 5-15
- GkTimeToLive, page 5-14
- GkId, page 5-14

GkId

Description

This parameter is the identifier for the primary H.323 gatekeeper.

Value Type

Alphanumeric string

Default

. (not specified)

Range

Maximum 31 characters

Voice Configuration Menu Access Code

91

GkTimeToLive

Description

This parameter specifies the “time to live” value that is used when the Cisco ATA registers with the H.323 gatekeeper. The registration is valid until the configured time expires.

Value Type

Integer

Default

0

Range

30 to 4294967295 seconds

Voice Configuration Menu Access Code

250

AltGk

Description

You have the option of using this parameter to statically specify the IP address of an alternate H.323 gatekeeper.

Value Type

Alphanumeric string

Range

Maximum number of characters: 31

Default

0

Voice Configuration Menu Access Code

6

Related Parameter

AltGkTimeOut, page 5-15

AltGkTimeOut

Description

You can use this parameter to specify the timeout in seconds before the Cisco ATA fails back to the primary gatekeeper from the backup gatekeeper. When the Cisco ATA switches to a different H.323 gatekeeper, the setting of Bit 3 of the ConnectMode parameter (see the “ConnectMode” section on page 5-32) determines whether the Cisco ATA re-registers with the H.323 gatekeeper.

Value Type

Integer

Default

0—The Cisco ATA continues to use the backup gatekeeper until it fails before attempting to fail back to the primary gatekeeper.

Range

30 to 4294967295 seconds

Voice Configuration Menu Access Code

251

Related Parameters

- AltGk, page 5-14
- ConnectMode, page 5-32—Bit 3

UID0

Description

This parameter is the User ID (E.164 phone number) for the **Phone 1** port. If the value is set to zero, the port will be disabled and no dial tone will sound.

Value Type

Alphanumeric string

Range

Maximum number of characters: 31

Default

0

Voice Configuration Menu Access Code

3

Related Parameters

- UID1, page 5-17
- PWD0, page 5-16
- PWD1, page 5-18
- UseLoginID, page 5-19
- LoginID0, page 5-18
- LoginID1, page 5-19

PWD0

Description

This parameter is the password for the **Phone 1** port.

Value Type

Alphanumeric string

Range

Maximum number of characters: 31

Default

0

Voice Configuration Menu Access Code

4

Related Parameters

- UID0, page 5-16
- UID1, page 5-17
- PWD1, page 5-18
- UseLoginID, page 5-19
- LoginID0, page 5-18
- LoginID1, page 5-19
- AutMethod, page 5-20

UID1

Description

This parameter is the User ID (E.164 phone number) for the **Phone 2** port. If the value is set to zero, the port will be disabled and no dial tone will sound.

Value Type

Alphanumeric string

Range

Maximum number of characters: 31

Default

0

Voice Configuration Menu Access Code

13

Related Parameters

- UID0, page 5-16
- PWD0, page 5-16
- PWD1, page 5-18
- UseLoginID, page 5-19
- LoginID0, page 5-18
- LoginID1, page 5-19

PWD1

Description

This parameter is the password for the **Phone 2** port.

Value Type

Alphanumeric string

Range

Maximum number of characters: 31

Default

0

Voice Configuration Menu Access Code

14

Related Parameters

- UID0, page 5-16
- UID1, page 5-17
- PWD0, page 5-16
- UseLoginID, page 5-19
- LoginID0, page 5-18
- LoginID1, page 5-19
- AutMethod, page 5-20

LoginID0

Description

This parameter is the H.323 login ID for the **Phone 1** port of the Cisco ATA.

This value is used for registration and authentication if the UseLoginID parameter is set to 1.

If the LoginID0 and LoginID1 parameter values are identical, only one gatekeeper registration is performed for both ports, in which case the LoginID0 value is used as the H.323 ID, and the UID0 and UID1 parameter values are used for the two E.164 phone numbers.

Value Type

Alphanumeric string

Range

Maximum number of characters: 51

Default

0

Voice Configuration Menu Access Code

46

Related Parameters

- LoginID1, page 5-19
- PWD0, page 5-16
- PWD1, page 5-18
- UseLoginID, page 5-19
- AutMethod, page 5-20

LoginID1

Description

This parameter is the H.323 login ID for the **Phone 2** port of the Cisco ATA.

This value is used for registration and authentication if the UseLoginID parameter is set to 1.

If the LoginID0 and LoginID1 parameter values are identical, only one gatekeeper registration is performed for both ports, in which case the LoginID0 value is used as the H.323 ID, and the UID0 and UID1 parameter values are used for the two E.164 phone numbers.

Value Type

Alphanumeric string

Range

Maximum number of characters: 51

Default

0

Voice Configuration Menu Access Code

47

Related Parameters

- LoginID0, page 5-18
- PWD0, page 5-16
- PWD1, page 5-18
- UseLoginID, page 5-19
- AutMethod, page 5-20

UseLoginID

Description

0—Use UID0 and UID1 as the authentication ID.

1—Use LoginID0 and LoginID1 as the authentication ID.

Value Type

Boolean

Range

0 or 1

Default

0

Voice Configuration Menu Access Code

93

AutMethod

Description

Use this parameter to select the desired authentication method, with the following possible values:

- 0—Do not use authentication (default)
- 1—Use Cisco registration-level security
- 2—Use Cisco administration-level security on a per-call basis

Value Type

Bitmap

Default

0x00000000

Voice Configuration Menu Access Code

92

Related Parameters

- LoginID0, page 5-18
- LoginID1, page 5-19
- PWD0, page 5-16
- PWD1, page 5-18
- NTPIP, page 5-10
- AltNTPIP, page 5-11

Gateway

Description

Use this parameter to specify the H.323 gateway IP address if the network does not contain an H.323 gatekeeper. In this scenario, all calls originating from the Cisco ATA will be directed to the gateway specified in this parameter.

Value Type

Alphanumeric string

Range

Maximum number of characters: 31

Default

0

Voice Configuration Menu Access Code

11

Audio Configuration Parameters

This section describes the following audio parameters, which allow you to configure such items as codecs and silence suppression:

- MediaPort, page 5-21
- RxCodec, page 5-22
- TxCodec, page 5-22
- LBRCodec, page 5-23
- AudioMode, page 5-24
- NumTxFrames, page 5-25
- TOS, page 5-26

MediaPort

Description

Use this parameter to specify the base port where the Cisco ATA transmits and receives RTP media. This parameter *must* be an even number. Each connection uses the next available even-numbered port for RTP.

Value Type

Integer

Range

1 to 65535

Default

16384

Voice Configuration Menu Access Code

202

Related Parameters

- TOS, page 5-26
- VLANSetting, page 5-12

RxCodec

Description

Use this parameter to specify receiving-audio codec preference. The following values are valid:

- 0—G.723 (can be selected only if LBRCodec is set to 0)
- 1—G.711A-law
- 2—G.711 μ -law
- 3—G.729A (can be selected only if LBRCodec is set to 3)

Value Type

Integer

Range

0-3

Default

2

Voice Configuration Menu Access Code

36

Related Parameters

- LBRCodec, page 5-23
- NumTxFrames, page 5-25
- TxCodec, page 5-22
- AudioMode, page 5-24

TxCodec

Description

Use this parameter to specify the transmitting-audio codec preference. The following values are valid:

- 0—G.723 (can be selected only if LBRCodec is set to 0)
- 1—G.711A-law
- 2—G.711 μ -law
- 3—G.729A (can be selected only if LBRCodec is set to 3)

Value Type

Integer

Range

0-3

Default

2

Voice Configuration Menu Access Code

37

Related Parameters

- LBRCodec, page 5-23
- NumTxFrames, page 5-25
- RxCodec, page 5-22
- AudioMode, page 5-24

LBRCodec

Description

This parameter allows you to specify which low-bit-rate codecs are available. The Cisco ATA is capable of supporting two G.723.1 connections or one G.729 connection. When G.723.1 is selected as the low-bit-rate codec, each FXS port is allocated with one G.723.1 connection. When G.729 is selected, only one FXS port is capable of operating with the G.729 codec. The allocation of the G.729 resource to the FXS port is dynamic. The G.729 resource, if available, is allocated to an FXS port when a call is initiated or received; the resource is released when a call is completed.

The following values are valid:

- 0—Select G.723.1 as the low-bit-rate codec.
- 3—Select either G.729 as the low-bit-rate codec.

Value Type

Integer

Range

0 or 3

Default

0

Voice Configuration Menu Access Code

300

Related Parameters

- AudioMode, page 5-24—Bits 1 and 17
- TxCodec, page 5-22
- RxCodec, page 5-22
- NumTxFrames, page 5-25

AudioMode

Description

This parameter represents the audio operating mode. The lower 16 bits are for the **Phone 1** port, and the upper 16 bits are for the **Phone 2** port. Table 5-1 on page 5-24 provides definitions for each bit.

Value Type

Bitmap

Default

0x00150015

Voice Configuration Menu Access Code

312

Related Parameters

- LBRCodec, page 5-23
- ConnectMode, page 5-32
- RxCodec, page 5-22

Table 5-1 AudioMode Parameter Bit Definitions

Bit Number	Definition
0 and 16	0/1—Disable/enable silence suppression for all audio codecs. Silence suppression is enabled by default.
1 and 17	0—Enable selected low-bit-rate codec in addition to G.711. This setting is the default. 1—Enable G.711 only.
2 and 18	0/1—Disable/enable fax CED tone detection. This feature is enabled by default.
3 and 19	Reserved.
4-5 and 20-21	DTMF Transmission Method: <ul style="list-style-type: none"> • 0—Always in-band. • 1—By negotiation. • 2—Always out-of-band. • 3—Reserved.
6-7 and 22-23	Hookflash Transmission Method: <ul style="list-style-type: none"> • 0—Disable sending OOB hookflash message. • 1—By negotiation (H.245 message). • 2—Always out-of-band (H.245 message). • 3—Use Q931 message to send user keypad information for DTMF or hookflash transmission.
8-15 and 23-31	Reserved.

NumTxFrames

Description

Use this parameter to select the number of frames per packet that the Cisco ATA transmits:

- The frame size for each G.729 data packet is 10 ms.
- The frame size for each G.723 data packet is 30 ms.

**Note**

The frame size for G.711 is fixed at 20 ms per packet and is not configurable.

Examples

- To obtain 60 ms of G.723 audio, set the parameter value to 2.
- To obtain 120 ms of G.723 audio, set the parameter value to 4.

**Note**

Cisco recommends using the default value of 2.

Value Type

Integer

Range

1-6

Default

2

Voice Configuration Menu Access Code

35

Related Parameters

- LBRCodec, page 5-23
- RxCodec, page 5-22
- TxCodec, page 5-22

TOS

Description

This parameter allows you to configure Type of Service (ToS) bits by specifying the precedence and delay of audio and signaling IP packets, as follows:

- Bits 0-7—These bits are for the ToS value for voice data packets.
Range: 0-255
Default: 184
- Bits 8-15—These bits are for the ToS value for signaling-data packets
Range: 0-255
Default: 168
- Bits 16-31—Reserved.

Value Type

Bitmap

Default

0x0000A8B8

Voice Configuration Menu Access Code

255



Note

This parameter is called UDPTOS in previous Cisco ATA releases. If you are performing a Cisco ATA upgrade, the previous value of the UDPTOS parameter is carried forward to the TOS parameter.

Operational Parameters

This section describes the following parameters, which allow you to configure such items as call features and various timeout values:

- CallFeatures, page 5-27
- PaidFeatures, page 5-28
- CallCmd, page 5-29
- FeatureTimer, page 5-30
- FeatureTimer2, page 5-31
- SigTimer, page 5-31
- ConnectMode, page 5-32
- OpFlags, page 5-34
- TimeZone, page 5-36

CallFeatures

Description

Disable/enable CallFeatures by setting each corresponding bit to 0 or 1.

The lower 16 bits are for the **Phone 1** port, and the upper 16 bits are for the **Phone 2** port. Table 5-2 provides definitions of each bit.



Note

The subscribed features that can be permanently disabled by the user are CLIP_CLIR, call waiting and Fax mode. A subscribed service enable/disabled by the user can be disabled/enabled dynamically on a per-call basis.

Value Type

Bitmap

Default

0xffffffff

Voice Configuration Menu Access Code

314

Related Parameters

- PaidFeatures, page 5-28
- CallCmd, page 5-29
- CallerIdMethod, page 5-38

Table 5-2 CallFeatures Parameter Bit Definitions

Bit Number	Definition
0 and 16	Not used for H.323.
1 and 17	Not used for H.323.
2 and 18	Not used for H.323.
3 and 19	Caller Line Identification Restriction (CLIR)—0; Caller Line Identification Presentation (CLIP)—1
4 and 20	Call waiting
5 and 21	Three-way calling
6 and 22	Not used for H.323.
7 and 23	Not used for H.323.
8 and 24	Caller ID. This service enables the Cisco ATA 186 to generate a Caller ID signal to drive a Caller ID display device attached to the FXS line.
9 and 25	Not used for H.323.
10 and 26	Not used for H.323.
11 and 27	Call Waiting Caller ID. This is available only if the Method bit in CallerIdMethod is set to Bellcore (FSK).

Table 5-2 *CallFeatures Parameter Bit Definitions (continued)*

Bit Number	Definition
12-14 and 28-30	Reserved.
15 and 31	Fax mode. This service allows the user to set the Cisco ATA to Fax mode on a per-call basis. For Fax mode, use the following settings: <ul style="list-style-type: none"> • G711 codec only • No silence suppression • No FAX tone detection

PaidFeatures

Description

Unsubscribe/subscribe to CallFeatures by setting each corresponding bit to either 0 or 1. The lower 16 bits are for the **Phone 1** port, and the upper 16 bits are for the **Phone 2** port. Table 5-3 provides definitions of each bit.

Value Type

Bitmap

Default

0xffffffff

Voice Configuration Menu Access Code

315

Related Parameters

- CallFeatures, page 5-27
- CallCmd, page 5-29
- CallerIdMethod, page 5-38
- SigTimer, page 5-31

Table 5-3 *PaidFeatures Parameter Bit Definitions*

Bit Number	Definition
0 and 16	Not used for H.323.
1 and 17	Not used for H.323.
2 and 18	Not used for H.323.
3 and 19	Caller Line Identification Restriction (CLIR)—0; Caller Line Identification Presentation (CLIP)—1
4 and 20	Call waiting
5 and 21	Three-way calling

Table 5-3 PaidFeatures Parameter Bit Definitions (continued)

Bit Number	Definition
6 and 22	Not used for H.323.
7 and 23	Not used for H.323.
8 and 24	Caller ID. This service enables the Cisco ATA 186 to generate a Caller ID signal to drive a Caller ID display device attached to the FXS line.
9 and 25	Not used for H.323.
10 and 26	Not used for H.323.
11 and 27	Call Waiting Caller ID.
12-14 and 28-30	Reserved.
15 and 31	Fax mode. This service allows the user to set the Cisco ATA to Fax mode on a per-call basis. For Fax mode, use the following settings: <ul style="list-style-type: none"> • G711 codec only • No silence suppression • No FAX tone detection

CallCmd

Description

Command table that controls call commands such as turning on/off caller ID.

For detailed information on the CallCmd parameter, see Chapter 6, “Call Commands.”

Value Type

Alphanumeric string

Range

Maximum of 248 characters

Default

U.S. Call Command Default

Af;AH;BS;NA;CS;NA;Df;EB;Ff;EP;Kf;EFh;HH;Jf;AFh;HQ;I*67;gA*82;fA#90v#;OI;H#72v#;bA#74v#;cA#75v#;dA#73;eA*67;gA*82;fA*70;iA*69;DA*99;xA;Uh;GQ;

Voice Configuration Menu Access Code

930

Related Parameters

- CallFeatures, page 5-27
- PaidFeatures, page 5-28
- CallerIdMethod, page 5-38
- SigTimer, page 5-31

FeatureTimer

Description

This parameter provides configurable timing values for various telephone features, as described below:

- Bits 1-15—Reserved.
- Bits 16-18—Configurable call waiting ring timeout. When a call arrives for a Cisco ATA port that is in use and has call-waiting enabled, the Cisco ATA plays a call-waiting tone. If the incoming call is not answered within a specified period of time, the Cisco ATA can reject the call by returning a "486 Busy" response to the remote user agent.

You can configure FeatureTimer parameter bits 16-18 to specify the ringing period for incoming call-waiting calls.

This feature can be disabled by either using the default value 0 or by setting bits 16-18 to a value greater than the standard timeout for an incoming call as specified in SigTimer parameter bits 14-19. When this feature is disabled, a "480 Temporarily Not Available" response is returned to the remote user agent when the standard ring times out.

- Range: 0 - 7
 - Factor: 10-second increments
 - Values: 0 to 70 seconds
 - Default: 0 (never timeout)
- Bits 19-31—Reserved.

Value Type

Bitmap

Default

0x00000000

Voice Configuration Menu Access Code

317

FeatureTimer2

Description

This parameter provides configurable timing values for various Cisco ATA features, as described below:

- Bits 0-7—Maximum time that the Ethernet connection can be disconnected before the Cisco ATA automatically reboots.
 - Range: 0 - 255
 - Factor: one-second increments
 - Values: 0 - 255 seconds
 - Default: 30 (equals 30 seconds)

**Note**

To disable this feature, set the value of bits 0-7 to 0.

Value Type

Bitmap

Default

0x0000001e

Voice Configuration Menu Access Code

361

SigTimer

Description

This parameter controls various timeout values. Table 5-4 on page 5-32 contains bit definitions of this parameter.

Value Type

Bitmap

Default

0x01418564

Voice Configuration Menu Access Code

318

Table 5-4 SigTimer Parameter Bit Definitions

Bit Number	Definition
0-7	Call waiting period—The period between each burst of call-waiting tone. Range: 0 to 255 in 0.1 seconds Default: 100 (0x64=100 seconds)
8-13	Reorder delay—The delay in playing the reorder (fast busy) tone after the far-end caller hangs up. Range: 0 to 62 in seconds Default—5 (seconds) 63—Never play the reorder tone.
14-19	Ring timeout—When a call is not answered, this is the amount of time after which Cisco ATA rejects the incoming call. Range—0 to 63 in 10 seconds Default—6 (60 seconds) 0—Never times out
20-25	Not used by H.323.
26-27	Minimum hook flash time—The minimum on-hook time required for hook flash event. Range: 0 to 3 Default: 0 (60 ms) Other possible values: 1=100 ms, 2=200 ms, 3=300 ms.
28-31	Maximum hook flash time—The maximum on-hook time allowed for hook flash event. Range: 0 to 15 Default: 0 (1000 ms) Other possible values: 1=100 ms, 2=200 ms, 3=300 ms, 4=400 ms, 5=500 ms, 6=600 ms, 7=700 ms, 8=800 ms, 9=900 ms, 10=1000 ms, 11=1100 ms, 12=1200 ms, 13=1300 ms, 14=1400 ms, 15=1500 ms.

ConnectMode

Description

This parameter is a 32-bit bitmap used to control the connection mode of the selected call signaling protocol. Table 5-5 on page 5-33 provides bit definitions for this parameter.

Value Type

Bitmap

Default

0x00060400

Voice Configuration Menu Access Code

311

Table 5-5 ConnectMode Parameter Bit Definitions

Bit Number	Definition
0	0—Use slow-start procedure (for H.225/Q.931 and H.245). 1—Use fast-start procedure (for H.225/Q.931). Default: 0
1	0/1—Disable/enable h245 tunneling. Default: 0
2	0—Use the dynamic payload type 126/127 as the RTP payload type (fax pass-through mode) for G.711 μ -law/G.711 A-law. 1—Use the standard payload type 0/8 as the RTP payload type (fax pass-through mode) for G.711 μ -law/G.711 A-law. Default: 0
3	0—Do not perform full gatekeeper registration when the Cisco ATA switches to an alternate H.323 gatekeeper. 1—Perform full gatekeeper registration when the Cisco ATA switches to an alternate H.323 gatekeeper. Default: 0
4	0—Denotes a non-Cisco CallManager environment. 1—Enable the Cisco ATA to operate in a Cisco CallManager environment. Default: 0
5	0/1—Enable/disable two-way cut-through of voice path before the Cisco ATA receives the CONNECT message. Default: 0
6	0/1—Disable/enable using the Progress Indicator to determine if ringback is supplied by the far end with RTP. Default: 0
7	0/1—Disable/enable fax pass-through redundancy. Default: 0
8-12	Specifies the fax pass-through NSE payload type. The value is the offset to the NSE payload base number of 96. The valid range is 0-23; the default is 4. For example, if the offset is 4, the NSE payload type is 100.
13	0—Use G.711 μ -law for fax pass-through codec. 1—Use G.711A-law for fax pass-through codec. Default: 0
14-15	0—Use fax pass-through. 1—Use codec negotiation in sending fax. 2—Reserved. 3—Reserved. Default: 0

Table 5-5 ConnectMode Parameter Bit Definitions (continued)

Bit Number	Definition
16	0/1—Disable check-bearer capability in the received Q.931 Setup message. If this setting is enabled, the Cisco ATA returns the value 65 as the release-complete cause if the Information Transfer Capability (ITC) is “unrestricted digital information” or “restricted digital information.” The Cisco ATA returns the value 100 as the release-complete cause if the ITC is “unrestricted digital information with tones/announcements” or “video.” Default: 0
17—18	Not used for H.323.
19	0—Disable sending ringback tone to the caller. 1—Enable sending ringback tone to the caller. Default: 0
20-22	Not used by H.323.
23	0/1—Disable/enable user-configurable setting for call-waiting default. If this value is 0 (default), the end user cannot configure the permanent default call-waiting setting for every call. Instead, the service provider's default call-waiting setting is used for every call. If this value is 1, the end-user can configure the permanent default call-waiting setting for every call, thus overriding the value set by the service provider. Default: 0
24	0/1—Disable/enable the mixing of audio and call waiting tone during a call. Default: 0
25 to 31	Reserved.

OpFlags

Description

This parameter enables/disables various operational features.
See Table 5-6 on page 5-35 for bit definitions of this parameter.

Value Type

Bitmap

Default

0x2

Voice Configuration Menu Access Code

323

Related Parameters

- TftpURL, page 5-5
- DHCP, page 5-8
- VLANSetting, page 5-12

Table 5-6 OpFlags Parameter Operational Features to Turn On or Off

Bit Number	Definition
0	<p>If Bit 0 = 0, the TFTP configuration filename supplied by the DHCP server overwrites the default filename for each Cisco ATA.</p> <p>If Bit 0 = 1, the default Cisco ATA filename is always used.</p> <p>Default: 0</p>
1	<p>If Bit 1 = 0, the Cisco ATA probes the static network router during the power-up process.</p> <p>If Bit 1 = 1, static network router probing is disabled.</p> <p>Default: 1</p>
2	Reserved.
3	<p>If Bit 3=1, the Cisco ATA does not request DHCP option 150 in the DHCP discovery message; some DHCP server do not respond if option 150 is requested.</p> <p>Default: 0</p>
4	<p>If Bit 4 = 1, the Cisco ATA use the VLAN ID specified in the VLANSetting parameter for VLAN IP encapsulation (see the “VLANSetting” section on page 5-12).</p> <p>Default: 0</p>
5	<p>If Bit 5=1, the Cisco ATA does not use VLAN IP encapsulation.</p> <p>Default: 0</p>
6	<p>If Bit 6=1, the Cisco ATA does not perform CDP discovery.</p> <p>Default: 0</p>
7	<p>If Bit 7=1, the Cisco ATA does not allow web configuration. Once the web server is disabled, you must configure the Cisco ATA with the TFTP or voice configuration menu methods.</p> <p>Examples</p> <ol style="list-style-type: none"> 1. If the existing OpFlags value is 0x2, select menu option 323 from the voice configuration menu and enter the value 130 (0x82). This disables web configuration. If you later attempt to access the Cisco ATA web configuration page, the following error messages will be displayed. <ul style="list-style-type: none"> - Netscape: The document contained no data. Try again later, or contact the server's administrator. - Internet Explorer: The page cannot be displayed. 2. If the existing OpFlags value is 0x82, select menu option 323 from the voice configuration menu and enter the value 2 (0x2). This disables web configuration. <p>Default: 0</p>
8	<p>If Bit 8=1, the Cisco ATA does not allow HTTP refresh access with the http://ip/refresh command.</p> <p>Default: 0</p>
9	<p>If Bit 9=1, the Cisco ATA does not allow HTTP reset access with the http://ip/reset command.</p> <p>Default: 0</p>
10	Reserved.

Table 5-6 OpFlags Parameter Operational Features to Turn On or Off (continued)

Bit Number	Definition
11	<p>If Bit 11=0, the Cisco ATA requests the device hostname from the DHCP server.</p> <p>If Bit 11=1, the Cisco ATA uses the device hostname that is specified in DHCP option 12.</p> <p>Default: 0</p>
12	Reserved.
13	<p>DNS Servers For Name Resolution</p> <p>If Bit 13=0 (default), use statically configured DNS IP addresses, if available, for name resolution. If statically configured DNS servers are not available, use DHCP-provided DNS IP addresses for name resolution.</p> <p>If Bit 13=1, use both statically configured DNS IP addresses and as many as two DHCP-provided DNS IP addresses. Therefore, the Cisco ATA can query as many as four DNS IP addresses in one DNS query.</p> <p>For more information about statically configured DNS IP addresses, see the “DNS1IP” section on page 5-11 section and the “DNS2IP” section on page 5-12 section.</p> <p>Default: 0</p>
14	<p>DNS Servers For Name Resolution 2</p> <p>If Bit 14=0 (default), use statically configured DNS IP addresses (DNS1IP and DNS2IP), if available, for name resolution; otherwise, use DHCP-provided DNS IP addresses.</p> <p>If Bit 14=1, use both statically configured (DNS1IP and DNS2IP) and DHCP-provided DNS IP addresses (maximum of two) for name resolution.</p> <p> Note This configuration bit gives precedence to statically provided DNS IP addresses over DHCP-provided DNS IP addresses. This bit also overrides the value of OpFlags parameter bit 13.</p>
15	<p>Disable UDP Checksum Generation</p> <p>If Bit 13=0, generate UDP checksum in outgoing UDP packets.</p> <p>If Bit 13=1, disable generation of of UDP checksum in outgoing UDP packets.</p> <p>Default: 0</p>
16-27	Reserved.
28-31	To configure the Cisco ATA to prompt the user for the UIPassword when the user attempts to perform a factory reset or upgrade using the voice configuration menu, configure bits 28 to 31 with the value of 6. Any other value for these bits means that the Cisco ATA will not prompt the user for the UIPassword in these cases.

TimeZone

Description

This parameter is the timezone offset (in hours) from Greenwich Mean Time (GMT) for time-stamping incoming calls with local time (to use for Caller ID display, for example). See the “Additional Description” heading later in the description of this parameter for selecting time offsets for timezones that have 30-minute-factor or 45-minute-factor offset from GMT.

Local time is generated by the following formula:

- Local Time=GMT + TimeZone, if TimeZone <= 12
- Local Time=GMT + TimeZone - 25, if TimeZone > 12

Value Type

Integer

Range

0-24

Default

17

Voice Configuration Menu Access Code

302

Additional Description

Use the following list to select Timezone offset (in minutes) from GMT for the following cities and countries that have 30-minute-factor and 45-minute-factor time zone offsets. These values are integers and can range from -720 through -60, and from 60 through 780.

- Tehran—210 = GMT + 3:30
- Kabul— 270 = GMT + 4:30
- Calcutta, Chennai, Mumbai, and New Delhi—330 = GMT + 5:30
- Kathmandu—345 = GMT + 5:45
- Rangoon—390 = GMT + 6:30
- Darwin and Adelaide—570 = GMT + 9:30
- Newfoundland— -210 = GMT - 3:30

**Note**

Negative timezone values must be configured through the Cisco ATA Web configuration page and cannot be configured with the voice configuration menu.

Related Parameters

- NTPIP, page 5-10
- AltNTPIP, page 5-11

Telephone Configuration Parameters

This section includes the following parameters, which allow you to configure items such as generating caller ID format and controlling line polarity:

- CallerIdMethod, page 5-38
- Polarity, page 5-39
- FXSInputLevel, page 5-40
- FXSOutputLevel, page 5-40

CallerIdMethod

Description

This 32-bit parameter specifies the signal format to use for both FXS ports for generating Caller ID format. Possible values are:

- Bits 0-1 (method)—0=Bellcore (FSK), 1=DTMF, 2=ETSI, and 3 is reserved.

If *method*=0 (default), set the following bits:

- Bit 2—Reserved.
- Bit 3 to 8—Maximum number of digits in phone number (valid values are 1 to 20; default is 12)
- Bit 9 to 14—Maximum number of characters in name (valid values are 1 to 20; default is 15)
- Bit 15—If this bit is enabled (it is by default), send special character **O** (out of area) to CID device if the phone number is unknown.
- Bit 16—If this bit is enabled (it is by default), send special character **P** (private) to CID device if the phone number is restricted.
- Bits 17 to 27—Reserved.

If *method*=1, set the following bits:

- Bit 2—Reserved.
- Bits 3-6—Start digit for known numbers (valid values are **12** for “A,” **13** for “B,” **14** for “C,” and **15** for “D.”)
- Bits 7-10—End digit for known numbers (valid values are **11** for “#,” **12** for “A,” **13** for “B,” **14** for “C,” and **15** for “D.”)
- Bits 11—Polarity reversal before and after Caller ID signal (value of 0/1 disables/enables polarity reversal)
- Bits 12-16—Maximum number of digits in phone number (valid values are 1 to 20; default is 15)
- Bits 17 to 19—Start digit for unknown or restricted numbers (valid values are **4** for “A,” **5** for “B,” **6** for “C,” and **7** for “D.”)
- Bits 20 to 22—End digit for unknown or restricted numbers (valid values are **3** for “#,” **4** for “A,” **5** for “B,” **6** for “C,” and **7** for “D.”)
- Bits 23 to 24—Code to send to the CID device if the number is unknown (valid values are **0** for “00,” **1** for “0000000000,” and **2** for “2.” **3** is reserved and should not be used.
- Bits 25 to 26—Code to send to the CID device if the number is restricted (valid values are **0** for “10,” and **1** for “1.” **2** and **3** are reserved and should not be used.
- Bits 27 to 31—Reserved.

If *method*=2, set the following bits:

- Bit 2—Set to 0 to have the Cisco ATA transmit data prior to ringing by using the Ring-Pulse Alerting Signal (RP-AS); set to 1 to have the Cisco ATA transmit data after the first ring.
- Bits 3-8—Maximum number of digits in a phone number (valid values are 1 to 20; default is 12).
- Bits 9-14—Maximum number of characters in a name (valid values are 1 to 20; default is 15).
- Bit 15—If this bit is enabled (it is enabled by default), send special character **O** (out of area) to CID device if telephone number is unknown.

- Bit 16—If this bit is enabled (it is enabled by default), send special character **P** (private) to CID device if telephone number is restricted.
- Bits 17-27 are reserved.

Examples

The following examples are recommended values for the CallerID Method parameter:

- USA = 0x00019e60
- Sweden = 0x006aff79 or 0x006aff61
- Denmark = 0x0000fde1 or 0x033efde1
- Germany = 0x00019e62
- Austria = 0x00019e66

Value Type

Bitmap

Default

0x00019e60

Voice Configuration Menu Access Code

316

Polarity

Description

You can control line polarity of the Cisco ATA FXS ports when a call is connected or disconnected by configuring the Polarity bitmap parameter as follows:

- Bit 0: CALLER_CONNECT_POLARITY. Polarity to use when the Cisco ATA is the caller and the call is connected.
 - 0 =Use forward polarity (Default)
 - 1 =Use reverse polarity
- Bit 1: CALLER_DISCONNECT_POLARITY. Polarity to use when the Cisco ATA is the caller and the call is disconnected.
 - 0 =Use forward polarity (Default)
 - 1 =Use reverse polarity
- Bit 2: CALLEE_CONNECT_POLARITY. Polarity to use when the Cisco ATA is the callee and the call is connected.
 - 0 =Use forward polarity (Default)
 - 1 =Use reverse polarity

- Bit 3: CALLEE_DISCONNECT_POLARITY. Polarity to use when the Cisco ATA is the callee and the call is disconnected.
 - 0 =Use forward polarity (Default)
 - 1 =Use reverse polarity



Note Bits 4-31 are reserved.

Value Type

Bitmap

Default

0x00000000

Voice Configuration Menu Access Code

304

FXSInputLevel

Description

Use this parameter to specify the input level control (analog-to-digital path) of the Cisco ATA FXS ports.

Value Type

Integer

Range

-9 to 2 dB

Default

-1

Voice Configuration Menu Access Code

370

Related Parameter

FXSOutputLevel, page 5-40

FXSOutputLevel

Description

Use this parameter to specify the output level control (digital-to-analog path) of the Cisco ATA FXS ports.

Value Type

Integer

Range

-9 to 2 dB

Default

-4

Voice Configuration Menu Access Code

371

Related Parameter

FXSInputLevel, page 5-40

Tone Configuration Parameters

The Cisco ATA supports the following tone parameters:

- DialTone
- BusyTone
- ReorderTone
- RingBackTone
- CallWaitTone
- AlertTone

The Cisco ATA supports two types of tone-parameter syntax—basic format and extended format. Basic format is used in most countries; use the extended format only if the country in which the Cisco ATA is used requires this format.

This section covers all the call-progress tones that the Cisco ATA supports, and contains the following topics:

- Tone Parameter Syntax—Basic Format, page 5-41
- Tone Parameter Syntax—Extended Formats, page 5-43
- Recommended Values, page 5-48
- Specific Tone Parameter Information, page 5-48

This section also covers the following parameter, which is for configuring phone-ringing characteristics:

- RingOnOffTime, page 5-51

**Note**

For detailed recommendations of tone-parameter values by country, see Appendix E, “Recommended Cisco ATA Tone Parameter Values by Country.”

Tone Parameter Syntax—Basic Format

Each tone is specified by nine integers, as follows:

parametername: NumOfFreqs, Tfreq1, Tfreq2, Tamp1, Tamp2, Steady, OnTime, OffTime, TotalToneTime

- *parametername* is the name of the tone.

- *NumOfFreqs* is the number of frequency components (0, 1 or 2).
- *Tfreq1* and *Tfreq2* are the transformed frequencies of the first and second frequencies, respectively. Their values are calculated with the following formula:

$$32767 * \cos(2 * \pi * F / 8000)$$

where *F* is the desired frequency in Hz. Set this value to **0** if the frequency does not exist.

The range of each value is -32768 to 32767 .

For negative values, use the 16-bit 2's complement value. For example, enter **-1** as 65535 or as $0xffff$.

- *Tamp1* and *Tamp2* are the transformed amplitudes of the first and second frequencies, respectively. Their values are calculated with the following formulas:

$$32767 * A * \sin(2 * \pi * F / 8000)$$

$$A \text{ (amplitude factor)} = 0.5 * 10^{((k+10-(n-1)*3)/20)}$$

where *F* is the desired frequency in Hz, *k* is the desired volume in *dBm*, and *n* is the number of frequencies. The ^ symbol means *to the order of*.

- *Steady* controls whether the tone is constant or intermittent. A value of **1** indicates a steady tone and causes the Cisco ATA to ignore the on-time and off-time parameters. A value of **0** indicates an on/off tone pattern and causes the Cisco ATA to use the on-time and off-time parameters.
- *OnTime* controls the length of time the tone is played in milliseconds (ms).
Specify each value as a number of samples with a sampling rate of 8 kHz. The range of each value is 0 to $0xffff$. For example, for a length of 0.3 seconds, set the value to 2400.
- *OffTime* controls the length of time between audible tones in milliseconds (ms).
Specify each value as a number of samples with a sampling rate of 8 kHz. The range of each value is 0 to $0xffff$. For example, for a length of 0.3 seconds, set the value to 2400.
- *TotalToneTime* controls the length of time the tone is played. If this value is set to 0, the tone will play until another call event stops the tone. For *DialTone*, *DialTone2*, *BusyTone*, *ReorderTone*, and *RingBackTone*, the configurable value is the number of 10 ms (100 = 1 second) units.
For the remaining tones, the configurable value is the number of samples with a sampling rate of 8 kHz.

Note

All tones are persistent (until the Cisco ATA changes state) except for the call-waiting tone and the confirm tone. The call-waiting tone, however, repeats automatically once every 10 seconds while the call-waiting condition exists.

Tone Parameter Syntax—Extended Formats

Two types of extended format exist for the Cisco ATA tone parameters:

- Extended Format A, page 5-43—This format can be used for the following tone parameters:
 - DialTone
 - BusyTone
 - RingbackTone
 - CallWaitTone
 - AlertTone
- Extended Format B, page 5-44—This format can be used only for the ReorderTone parameter.

Extended Format A

Each tone is specified by 11 integers, as follows:

parametername:NumOfFreqs, Tfreq1, Tamp1, Tfreq2, Tamp2, NumOfOnOffPairs, OnTime1, OffTime1, OnTime2, OffTime2, TotalToneTime

- *parametername* is the name of the tone.
- *NumOfFreqs* = 100 + the number of frequencies in the tone. (Therefore, *NumOfFreqs* = 101 for one frequency, and 102 for two frequencies.)
- *Tfreq1* and *Tfreq2* are the transformed frequencies of the first and second frequencies, respectively. Their values are calculated with the following formula:

$$32767 * \cos(2 * \pi * F / 8000)$$

where *F* is the desired frequency in Hz. Set this value to 0 if the frequency does not exist.

The range of each value is -32768 to 32767.

For negative values, use the 16-bit 2's complement value. For example, enter -1 as 65535 or as 0xffff.

- *Tamp1* and *Tamp2* are the transformed amplitudes of the first and second frequencies, respectively. Their values are calculated with the following formula:

$$32767 * A * \sin(2 * \pi * F / 8000)$$

$$A \text{ (amplitude factor)} = 0.5 * 10^{((k+10-(n-1)*3)/20)}$$

where *F* is the desired frequency in Hz, *k* is the desired volume in *dBm*, and *n* is the number of frequencies. The ^ symbol means *to the order of*.

- *NumOfOnOffPairs* is the number of on-off pairs in the cadence of the tone. Valid values are 0, 1 and 2. Use 0 if the tone is steady.
- *OnTime1* and *OnTime2* values are the lengths of time the tone is played for the first and second on-off pairs of a cadence, respectively. (See Figure 5-1 for a graphical representation.)

Specify each value as a number of samples with a sampling rate of 8 kHz. The range of each value is 0 to 0xffff. For example, for a length of 0.3 seconds, set the value to 2400.

- *OffTime1* and *OffTime2* values are the lengths of time that silence is played for the first and second on-off pairs of a cadence, respectively. (See Figure 5-1 for a graphical representation.)

Specify each value as a number of samples with a sampling rate of 8 kHz. The range of each value is 0 to 0xffff. For example, for a length of 0.3 seconds, set the value to 2400.

Figure 5-1 Cadence With Two On-Off Pairs

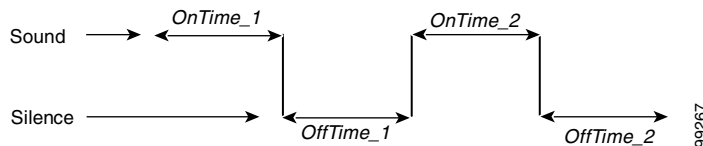

- *TotalToneTime* controls the length of time the tone is played. If this value is set to 0, the tone will play until another call event stops the tone. For *DialTone*, *DialTone2*, *BusyTone*, *ReorderTone*, and *RingBackTone*, the configurable value is the number of 10 ms (100 = 1 second) units.

For the remaining tones, the configurable value is the number of samples with a sampling rate of 8 kHz.



Note

All tones are persistent (until the Cisco ATA changes state) except for the call-waiting tone and the confirm tone. The call-waiting tone, however, repeats automatically once every 10 seconds while the call-waiting condition exists.

Extended Format B

The *ReorderTone* parameter specifies the tone that the Cisco ATA plays when the called number is not available or the external circuit is busy. This tones can consist of:

- Up to three frequencies played simultaneously and a cadence of up to three on-off pairs. The first on-off pair can repeat multiple times before the second on-off pair plays.
For example, a 400 Hz frequency plays four times for 0.75 second followed by 0.1 second of silence after each play and then plays one time for 0.75 second followed by 0.4 second of silence. This pattern can be set to repeat until another call event stops the pattern.
- Up to three frequencies played sequentially with a cadence of up to three on-off pairs
For example, the frequencies 900 Hz, 1400 Hz, and 1800 Hz play sequentially for 0.33 seconds each with no silence after the first and second frequencies but one second of silence after the third frequency.

The syntax of the *ReorderTone* parameter is specified by 17 integers, as follows:

```
ReorderTone: Sequential, NumOfFreqs, TFreq1, TAMP1, TFreq2,
TAMP2, TFreq3, TAMP3, NumOfOnOffPairs, OnTime1, OffTime1,
OnTime2, OffTime2, OnTime3, OffTime3, NumOfRepeats, TotalToneTime
```

where:

- *Sequential* specifies whether multiple frequencies in a tone play simultaneously (100) or sequentially (101). Set to 100 for a tone with one frequency. If *Sequential* is 101, the number of frequencies (*NumOfFreqs*) has to be the same value as the number of on-off pairs in a cadence (*NumOfOnOffPairs*).
- *NumOfFreqs* is the number of frequencies in the tone (1, 2, or 3). The frequencies can play simultaneously or sequentially, depending on the *Sequential* setting.

- $TFreq1$, $TFreq2$, and $TFreq3$ are the transformed frequencies of the first, second, and third frequencies, respectively. Calculate each value with the following formula:

$$32767 * \cos(2 * \pi * F/8000)$$

where F is the desired frequency in Hz. Set this value to 0 if the frequency does not exist.

The range of each value is -32768 to 32767.

For negative values, use the 16-bit 2's complement value. For example, enter -1 as 65535 or as 0xffff.
- $Tamp1$, $Tamp2$ and $Tamp3$ are the transformed amplitudes of the first, second and third frequencies, respectively. Their values are calculated with the following formula:

$$32767 * A * \sin(2 * \pi * F/8000)$$

A (amplitude factor) = $0.5 * 10^{((k+10-(n-1)*3)/20)}$

where F is the desired frequency in Hz, k is the desired volume in dBm, and n is the number of frequencies (If *Sequential* is set to 101, n is equal to 1). The ^ symbol means *to the order of*.
- $NumOfOnOffPairs$ is the number of on-off pairs in the cadences of the tone (0, 1, 2, or 3). For a steady tone, use 0.

If this value is 0, the $OnTime1$, $OnTime2$, $OnTime3$, $OffTime1$, $OffTime2$, and $OffTime3$ values must also be 0.
- $OnTime1$, $OnTime2$, and $OnTime3$ are the lengths of time that the first, second, and third on-off pairs of a cadence play a sound, respectively. (See Figure 5-2 for a graphical representation.)

Specify each value as a number of samples with the sampling rate of 8 kHz. The range of each value is 0 to 0xffff.

For example, for a length of 0.3 seconds, set a value to 2400.
- $OffTime1$, $OffTime2$, and $OffTime3$ are the lengths of silence after the sound of the first, second, and third on-off pairs of a cadence, respectively.

Specify each value as a number of samples with the sampling rate of 8 kHz. The range of each value is 0 to 0xffff.

For example, for a length of 0.3 seconds, set a value to 2400. (See Figure 5-2 for a graphical representation.)

Figure 5-2 Cadence with Three On-Off Pairs

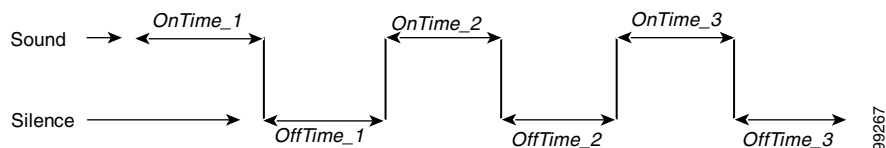

- $NumOfRepeats$ is the number of times that the first on-off pair of the cadence (specified by $OnTime1$, $OffTime1$) repeats before the second on-off pair (specified by $OnTime2$, $OffTime2$) plays.

For example, if $NumOfRepeats$ is 2, the first on-off pair will play three times (it will play once and then repeat two times), then the second on-off pair will play.
- $TotalToneTime$ is the total length of time that the tone plays. If this value is 0, the tone will play until another call event stops the tone.

This value is in 10 ms units (100 ms = 1 second).

Two examples of Extended Format B, both using the Reorder tone, follow.

ReorderTone Parameter Example1

Assume that you want a reorder tone in which:

- The frequencies 900 Hz, 1400 Hz, and 1800 Hz play sequentially.
- Each frequency plays once for 0.33 seconds.
- There is no silence after the first and the second frequencies.
- There is 1 second of silence after the third frequency (before the first frequency starts again)
- The volume of each frequency is –19 dBm.
- The tone plays until another call event stops the tone.

For this reorder tone, make the following setting. See Table 5-7 for a detailed explanation.

```
ReorderTone:101,3,24917,3405,14876,4671,5126,5178,3,2640,0,2640,0,
2640,8000,0,0
```

Table 5-7 Reorder Tone Parameter Example 1 Explanation

Component	Setting	Explanation
Sequential	101	Frequencies play sequentially
NumOfFreqs	3	Three frequencies in the tone
TFreq1	24917	First frequency is 900 Hz
TAmp1	3405	First frequency volume is –19 dBm
TFreq2	14876	Second frequency is 1400 Hz
TAmp2	4671	Second frequency volume is –19 dBm
TFreq3	5126	Third frequency is 1800 Hz
TAmp3	5178	Third frequency volume is –19 dBm
NumOfOnOffPairs	3	Three on-off pairs in the cadence of the tone
OnTime1	2640	Sound in first on-off pair plays for 0.33 seconds
OffTime	0	No silence after the first sound (the second sound plays immediately)
OnTime2	2640	Sound in second on-off pair plays for 0.33 seconds
OffTime2	0	No silence after the second sound (the third sound plays immediately)
OnTime3	2640	Sound in third on-off pair plays for 0.33 seconds
OffTime3	8000	1 second of silence after the sound in the third on-off pair (before the pattern repeats, beginning with the first on-off pair)

Table 5-7 Reorder Tone Parameter Example 1 Explanation (continued)

Component	Setting	Explanation
NumOfRepeats	0	First on-off pair of the cadence plays once (does not repeat), then the second on-off pair plays
TotalToneTime	0	Tone plays continuously (set of three on-off pairs of the cadence repeat continuously) until another call event stops the tone

ReorderTone Parameter Example 2

Assume that you want a reorder tone in which:

- The only frequency is 400 Hz.
- The frequency plays six times, each time for 0.1 second followed by 0.9 second of silence.
- The frequency then plays once for 0.3 second followed by 0.7 second of silence.
- The volume of the frequency is -19 dBm.
- The tone plays until another call event stops the tone.

For this reorder tone, make the following setting. See Table 5-8 for a detailed explanation.

```
ReorderTone:100,1,31164,1620,0,0,0,0,2,800,7200,2400,5600,0,0,5,0
```

Table 5-8 Reorder Tone Parameter Example 2 Explanation

Component	Setting	Explanation
Sequential	100	Required setting for a tone with one frequency
NumOfFreqs	1	One frequency in the tone
TFreq1	31164	First frequency is 400 Hz
TAmp1	1620	First frequency volume is -19 dBm
TFreq2	0	No second frequency
TAmp2	0	No second frequency
TFreq3	0	No third frequency
TAmp3	0	No third frequency
NumOfOnOffPairs	2	Two on-off pairs in the cadence of the tone
OnTime1	800	Sound in first on-off pair plays for 0.1 second
OffTime1	7200	Sound in first on-off pair is followed by 0.9 second of silence
OnTime2	2400	Sound in second on-off pair plays for 0.3 seconds
OffTime2	5600	Sound in second on-off pair is followed by 0.7 second of silence
OnTime3	0	No third on-off pair in the cadence
OffTime3	0	No third on-off pair in the cadence

Table 5-8 Reorder Tone Parameter Example 2 Explanation (continued)

Component	Setting	Explanation
NumOfRepeats	5	First on-off pair of the cadence plays six times (plays once and then repeats five times), then the second on-off pair plays
TotalToneTime	0	Tone plays continuously (set of two on-off pairs of the cadence repeat continuously) until another call event stops the tone

Recommended Values

The following settings are recommended for the US:

- DialTone = "2,31538,30831,1380,1740,1,0,0,1000" (approximately -17 dBm)
- BusyTone = "2,30467,28959,1191,1513,0,4000,4000,0" (approximately -21 dBm)
- ReorderTone = "2,30467,28959,1191,1513,0,2000,2000,0" (approximately -21 dBm)
- RingBackTone = "2,30831,30467,1943,2111,0,16000,32000,0" (approximately -16 dBm)
- CallWaitTone = "1,30831,0,5493,0,0,2400,2400,4800" (approximately -10 dBm)
- AlertTone = "1,30467,0,5970,0,0,480,480,1920"



Note

For detailed recommendations of tone-parameter values by country, see Appendix E, "Recommended Cisco ATA Tone Parameter Values by Country."

Specific Tone Parameter Information

Brief descriptions, and lists of default values and the voice configuration menu code for each Cisco ATA tone parameter, appear in the following sections:

- DialTone, page 5-48
- BusyTone, page 5-49
- ReorderTone, page 5-49
- RingbackTone, page 5-50
- CallWaitTone, page 5-50
- AlertTone, page 5-51

DialTone

Description

The Cisco ATA plays the dial tone when it is ready to accept the first digit of a remote address to make an outgoing call.

Default values (using the Basic format)

- NumOfFreqs—2

- Tfreq1—31538
- Tfreq2—30831
- Tamp1—1380
- Tamp2—1740
- Steady—1
- OnTime—0
- OffTime—0
- TotalToneTime—1000

Voice Configuration Menu Access Code

920

BusyTone

Description

The Cisco ATA plays the busy tone when the callee is busy.

Default values (using the Basic format)

- NumOfFreqs—2
- Treq1—30467
- Tfreq2—28959
- Tamp1—1191
- Tamp2—1513
- Steady—0
- OnTime—4000
- OffTime—4000
- TotalToneTime—0

Voice Configuration Menu Access Code

921

ReorderTone

Description

The Cisco ATA plays the reorder tone (also known as congestion tone) if the outgoing call failed for reasons other than busy. This is a fast-busy tone.

Default values (using the Basic format)

- NumOfFreqs—2
- Treq1—30467
- Treq2—28959
- Tamp1—1191

- Tamp2—1513
- Steady—0
- OnTime—2000
- OffTime—2000
- TotalToneTime—0

Voice Configuration Menu Access Code

922

RingbackTone

Description

The Cisco ATA plays the ring-back tone when the callee is being alerted by the called device.

Default values (using the Basic format)

- NumOfFreqs—2
- Tfreq1—30831
- Tfreq2—30467
- Tamp1—1943
- Tamp2—2111
- Steady—0
- OnTime—16000
- OffTime—32000
- TotalToneTime—0

Voice Configuration Menu Access Code

923

CallWaitTone

Description

The Cisco ATA plays the call-waiting tone when an incoming call arrives while the user is connected to another party.

Default values (using the Basic format)

- NumOfFreqs—1
- Tfreq1—30831
- Tfreq2—0
- Tamp1—5493
- Tamp2—0
- Steady—0
- OnTime—2400

- OffTime—2400
- TotalToneTime—4800

Voice Configuration Menu Access Code

924

AlertTone

Description

The Cisco ATA plays the alert tone as a confirmation tone that a special event, such as call forwarding, is in effect.

Default values (using the Basic format)

- NumOfFreqs—1
- Tfreq1—30467
- Treq2—0
- Tamp1—5970
- Tamp2—0
- Steady—0
- OnTime—480
- OffTime—480
- TotalToneTime—1920

Voice Configuration Menu Access Code

925

RingOnOffTime

Description

This parameter specifies the ringer cadence pattern, expressed as a triplet of integers “a,b, and c”.

- a—Number of seconds to turn the ring ON.
- b—Number of seconds to turn the ring OFF.
- c—The ring frequency, fixed at 25.

Value Type

List of three integer values, separated by commas

Range

1-65535

Default

2, 4, 25

Recommended Values:

- United States — 2,4,25
- Sweden — 1,5,25

Voice Configuration Menu Access Code

929

Dial Plan Parameters

This section describes the configurable parameters related to dial plans:

- DialPlan, page 5-52
- DialPlanEx, page 5-60
- IPDialPlan, page 5-60

DialPlan

Description

The programmable dial plan is designed for the service provider to customize the behavior of the Cisco ATA for collecting and sending dialed digits. The dial plan allows the Cisco ATA user to specify the events that trigger the sending of dialed digits. These events include the following:

- The termination character has been entered.
- The specified dial string pattern has been accumulated.
- The specified number of dialed digits has been accumulated.
- The specified inter-digit timer has expired.

Value Type

Alphanumeric string

Range

Maximum number of characters is 199.

**Note**

If the dial plan exceeds 199 characters, use the DialPlanEx parameter instead of the DialPlan parameter. For more information, see the “DialPlanEx” section on page 5-60.

Default

*St4-|#St4-|911|1>#t8.r9t2-|0>#t811.rat4-|^1t4>#.-

Voice Configuration Menu Access Code

926

Additional DialPlan Information

The DialPlan section contains the following additional topics that describe commands and rules for creating your own dial plan, and includes many examples:

- Dial Plan Commands, page 5-53
- Dial Plan Rules, page 5-54
- Dial Plan Examples, page 5-58

Dial Plan Commands

The following list contains commands that can be used to create you own dial plans:

- `.`—Wildcard, match any digit entered.
- `-`—Additional digits can be entered. This command can be used only at the end of a dial plan rule (for example, 1408t5- is legal usage of the - command, but 1408t5-3... is illegal).
- `[]`—Range, which means to match any single digit in the list. Use an underscore (`_`) to indicate a range of digits. For example, `[135]` matches the digits 1, 3, and 5. Also, `[1_5]` matches the digits 1, 2, 3, 4 and 5. The pound key (`#`) and asterisk (`*`) are not allowed in the Range command. Also, the Repeat (`rn`) command does not apply to range, and range cannot include the Subrule matching command.
- `(subrule0| subrule1| ...|subruleN)`—Subrule matching. Using the `()` and `|` operators allows you to specify multiple subrules within a dial plan rule so that a subrule match is reached if the entered digits fit one of the subrules. This can be used to reduce the length of the desired dial plan rule by concatenating the group of the subrules with the common rule.

For example, a dial plan rule of `(1900|1800|17..)555.r3` or three dial plan rules of `1900555.r3|1800555.r3|17..555.r3` are equivalent. A match is reached if 11 digits are entered and the first three digits are either 1900, 1800, or 17..., and the fifth, sixth, and seventh digits are all 5.

- `>#`—Defines the `#` character as a termination character. When the termination character is entered, the dial string is automatically sent. The termination character can be entered only after at least one user-entered digit matches a dial plan rule. Alternatively, the command `>*` can be used to define `*` as the termination character.
- `tn`— Defines the timeout value `n`, in the unit of seconds, for the interdigit timer. Valid values are 0-9 and a-z, where a-z indicates a range of 10 to 35.
- `rn`—Repeat the last pattern `n` times, where `n` is 0-9 or a-z. The values a-z indicate a range of 10 to 26. Use the repeat modifier to specify more rules in less space.



Note The commands `>#` and `tn` are modifiers, not patterns, and are ignored by the `rn` command.

- `|`—Used to separate multiple dial plan rules.
- `^`—Logical not. Match any character except the character immediately following the `^` command. The `^` command can also be used as a negation instruction before the range or subrule matching commands.
- `S`—Seize rule matching. If a dial plan rule matches the sequence of digits entered by the user to this point, and the modifier `S` is the next command in the dial plan rule, all other rules are negated for the remainder of the call (for example, a dial plan beginning with `*S` will be the only one in effect if the user first enters the `*` key).



Note

All rules apply in the order listed (whichever rule is completely matched first will immediately send the dial string).

**Note**

No syntax check is performed by the actual implementation. The administrator has the responsibility of making sure that the dial plan is syntactically valid.

Dial Plan Rules

The Cisco ATA supports the following dial plan rules:

- (In Rule) for Dial Plan Blocking, page 5-54
- ‘H’ Rule to Support Hot/Warm Line, page 5-54
- ‘P’ Rule to Support Dial Prefix, page 5-55
- ‘R’ Rule for Enhanced Prefix, page 5-55
- ‘C’ Rule for Call Blocking, page 5-56
- ‘F’ Rule for Call Forwarding Blocking, page 5-56
- ‘X’ Rule for Call Blocking and Call Forwarding Blocking, page 5-57
- ‘D’ Rule for Displaying Caller ID, page 5-57

(In Rule) for Dial Plan Blocking

Dial plan blocking can be used to reduce the occurrences of invalid dialed digits being sent and can prevent the dialed string of a specified pattern from being sent. By adding dial plan blocking, dialed digits are discarded after the interdigit timer expires unless one of the specified matching rules is met.

In addition, the default nine-second global interdigit timeout value is also modified with the value specified in the dial plan blocking command:

Syntax

`In n`

where *n* specifies the global interdigit timeout and the valid values are 1-9 and a-z (10-35).

Example

`In 12| 911`

This command specifies an interdigit timeout of 12 seconds, and will discard dialed digits unless 911 is entered.

Specifying your own interdigit timeout also changes the behavior of the dial plan so that the entire dial string, rather than being sent at timeout, is sent only as a result of a matching rule or time intended by a matching rule.

‘H’ Rule to Support Hot/Warm Line

Hotline/Warmline, also known as Private Line Automatic Ringdown (PLAR), is a line used for priority telephone service. If the Hotline feature is configured, the Cisco ATA immediately dials a pre-configured number as soon as the handset goes off hook. If the Warmline feature is configured, the Cisco ATA dials a pre-configured number if no digits were entered before the specified timer value expired when the handset went offhook.

Syntax*Hdnnnn*

where *d* is a delay-in-seconds parameter 0-9,a-z (to support 0 to 35 seconds delay), and *nnnn* is the variable-length phone number to call when no digits are entered for *d* seconds after offhook.

Example 1*H05551212*

This is a hotline configuration; the Cisco ATA immediately dials 555-1212 when the handset goes off hook.

Example 2*H55551212*

This is a warmline configuration; the Cisco ATA waits for five seconds and dials 555-1212 if no digits were entered when the handset went off hook.

'P' Rule to Support Dial Prefix

This rule is for automatic pre-pending the dial string as entered by the user with a specified prefix.

Syntax*Ptnnnn*

where *t* is a single leading trigger character; if *t* is the *first* entered digit when making a new call, it triggers the prepending of a variable-length prefix (as specified by *nnnn*) in the dial string. The *t* character can take one of the following values:

0-9,*,#, 'n' (= any of 1-9), 'N' (any of 'n' and 0), 'a' (any of 'n',* and #), or 'A' (any of 'a' and 0);

Example*Pn12345*

This rule prepends 12345 to the dial string when the first entered digit is any of 1-9. The triggered digit is not removed from the dial string.

'R' Rule for Enhanced Prefix

This enhanced prefix rule matches entire strings, whereas the 'P' rules matches only a single digit. The 'R' rule is for automatically prepending a specified prefix to the dialed string. The string must be an exact match to trigger the rule. If more than one 'R' rule matches, the first matched 'R' rule is triggered.

The 'R' rule also uses negation to exclude one or more leading digits before prepending the defined prefix string.

The number of dashes (-) after the *R* represents the number of leading digits that will be removed preceding the prefix.

Syntax*Rnnnn (tttt)*

where *tttt* is a trigger string. If the dialed numbers match this string, this match triggers the prepending of a variable-length prefix (as specified by *nnnn*) to the dial string. The triggered string is not removed from the dial string. The negation, subrule matching and range patterns can be applied to the trigger strings.

Example 1

```
R1212 ([2_9] -)
```

This rule prepends 1212 to dial strings that have a leading digit of 2 to 9.

**Note**

Note: 'R' rules can replace most 'P' rules; for example, *Pn12345* is the same as *R12345([1_9]-)*.

Example 2

```
R-0033 (0 [1-9] .r7)
```

This removes the first dialed digit, then prepends 0033 to the dialed string. For example, if the number 0148336134 is dialed, the resulting string becomes 0033148336134.

Example 3

```
R---0 (0033 [1-9] .r7)
```

This removes the first four dialed digits, then prepends 0 to the dialed string. For example, if the number 0033148336134 is dialed, the resulting string becomes 0148336134.

Log Information

The *Call Prefix* <prefix>+<num> is shown in the prserv log.

'C' Rule for Call Blocking

This rule is for blocking call numbers.

Syntax

```
Cnnnn
```

where *nnnn* is the leading set of digits of the blocked call number; *nnnn* can be composed with subrule matching and range. The rule is triggered when the leading digits of a dialed string match the string *nnnn*.

The 'C' rule does not work with negation.

Example:

```
C1900|C1888 or C(1900|1888)
```

This rule blocks call numbers beginning with 1900 or 1888.

Log Information

The *Call Block* <num> is shown in the prserv log, and a busy tone is being played.

'F' Rule for Call Forwarding Blocking

This rule is for blocking call forwarding numbers.

Syntax

```
Fnnnn
```

where *nnnn* is the leading set of digits of the blocked call forwarding number; *nnnn* can be composed with subrule matching and range. The rule is triggered when the leading digits of a dialed forwarding number match the string *nnnn*. The 'F' rule does not work with negation.

Example:

```
F1900|F1888 OR F(1900|1888)
```

These rules block call forwarding numbers beginning with 1900 or 1888.

Log Information

The *CFWD Block:<num>* is shown in the prserv log, and a busy tone is being played.

'X' Rule for Call Blocking and Call Forwarding Blocking

This rule is for blocking call numbers and call forwarding numbers.

Syntax

```
Xnnnn
```

where *nnnn* is the leading set of digits of the blocked call number and blocked call forwarding number; *nnnn* can be composed with subrule matching and range. The rule is triggered when the leading set of digits of a dialed call number or forwarding number match the string *nnnn*. The 'F' rule does not work with negation.

Example

```
X1900|X1888 OR X(1900|1888)
```

This rule blocks the call numbers and call forwarding numbers beginning with 1900 or 1888.

'D' Rule for Displaying Caller ID

This rule is for displaying caller ID at the remote site. The number must be an exact match to trigger the rule.

Syntax

```
Dnnnn
```

where *nnnn* is the callee number. The caller ID will show to the callee; *nnnn* automatically becomes a valid calling number. Also, *nnnn* can be composed with negation, subrule matching and range. The 'D' rule is checked before the 'R' and 'P' rules.

Example

```
D911
```

This rule shows the caller ID at the remote side when if the call number is 911.

Log Information

SCC Cmd[]:CLIP or *CLIP:<num>* are shown in the prserv log.

Dial Plan Examples

This section contains three dial plan examples that use many different rules and commands.

Dial Plan Example 1 (Default Dial Plan)

The following dial plan:

```
*St4-|#St4-|911|1>#t8.r9t2-|0>#t811.rat4-|^1t4>#.-
```

consists of the following rules:

- ***St4**—If the first digit entered is *, all other dial plan rules are voided. Additional digits can be entered after the initial * digit, and the timeout before automatic dial string send is four seconds.
- **#St4**—Same as above, except with # as the initial digit entered.
- **911**—If the dial string 911 is entered, send it immediately.
- **1>#t8.r9t2**—If the first digit entered is 1, the timeout before automatic send is eight seconds. The terminating character # can be entered at any time to manually send the dial string. After the 11th digit is entered, the timeout before an automatic send changes to two seconds. The user can enter more digits until the dial string is sent by the timeout or by the user entering the # character.
- **0>#t811.rat4**—If the first digit entered is 0, the timeout before automatic send is eight seconds, and the terminating character # can be entered at any time to manually send the dial string. If the first three digits entered are 011, then, after an additional 11 digits are entered, the timeout before an automatic send changes to four seconds. The user can enter more digits until the dial string is sent by the timeout or by the user entering the # character.
- **^1t4>#**—If the first digit entered is anything other than 1, the timeout before an automatic send is four seconds. The terminating character # can be entered at any time to manually send the dial string. The user can enter more digits until the dial string is sent by the timeout or by the user entering the # character.

Dial Plan Example 2

The following dial plans:

```
.t7>#. . . . .t4- | 911 | 1t7>#. . . . .t1- | 0t4>#.t7-
```

or

```
.t7>#r6t4- | 911 | 1t7>#.r9t1- | 0t4>#.t7-
```

consist of the following rules:

- **.t7>#r6t4-**—You must enter at least one digit. After the first digit is entered and matched by the dial plan, the timeout before an automatic send is seven seconds, and the terminating character # can be entered at any time to manually send the dial string. After seven digits are entered, the timeout before an automatic send changes to two seconds. The **- symbol** at the end of the rule allows further digits to be entered until the dial string is sent by the timeout or the user entering the # character.
- **911**—If the dial string 911 is entered, send this string immediately.
- **1t7>#.r9t1-**—If the first digit entered is 1, the timeout before an automatic send is seven seconds, and the terminating character # can be entered at any time to manually send the dial string. After the 11th digit is entered, the timeout before an automatic send changes to one second. The user can enter more digits until the dial string is sent by the timeout or by the user entering the # character.
- **0t4>#.t7-**—If the first digit entered is 0, the timeout before an automatic send is four seconds, and the terminating character # can be entered at any time to manually send the dial string. After the second digit is entered, the timeout before an automatic send changes to seven seconds. The user can enter more digits until the dial string is sent by the timeout or by the user entering the # character.

Dial Plan Example 3

The following dial plan:

```
R1408([2_9].r5|[2_9].r6) | R9^(911|.r4) | X(1900|1888) | F011
```

consists of the following rules:

- **R1408([2_9].r5|[2_9].r6)**—The prefix 1408 will be added to any call numbers with seven or eight digits where the leading digit is in the range of 2 to 9. For example, 5551234 will become 14085551234, but 555123 does not match this rule.
- **R9^(911|.r4)**— The prefix 9 will added to any numbers except 911 and five-digit numbers. For example, 911 will still be 911, and 51234 will still be 51234.
- **X(1900|1888)**— There will be no calls or call forwarding to numbers beginning with 1900 or 1888.
- **F011**—There will be no call forwarding to numbers beginning with 011.

In Dial Plan Example 3, there are two 'R' rules, so the first matched rule is triggered. Therefore, 5551234 becomes 14085551234. However, 555123 will then become 9555123 because it matches the second rule.

DialPlanEx

If your dial plan exceeds 199 characters, then you must use the DialPlanEx parameter to configure your dial plans. The DialPlanEx parameter supports dial plans up to 499 characters in length. This range in the number of characters is the only difference between the DialPlanEx and DialPlan parameters. Therefore, all the information about the DialPlan parameter applies to the DialPlanEx parameter. For more information, see the “DialPlan” section on page 5-52.

Note

If you are not using this parameter for dial plan configuration, be sure this parameter is set to 0.

IPDialPlan

Description

This parameter allows for detection of IP-like destination address in DialPlan. Three values are valid:

- 0—String is dialed as is and not treated as an IP address.
- 1—When the Cisco ATA detects two asterisks (**), IPDialPlan takes over. The user enters the pound (#) key to terminate the digit collection, and the interdigit timeout default is not used.
- 2—When IPDialPlan is set to 2, three asterisks (***) are required for IPDialPlan to take effect.

All other values are currently undefined.

Value Type

Integer

Range

0, 1 or 2

Default

1

Voice Configuration Menu Access Code

310

Diagnostic Parameters

This section describes the following parameters, which are used for diagnostic purposes:

- NPrintf, page 5-61
- SyslogIP, page 5-61
- SyslogCtrl, page 5-62

NPrintf

Description

Use this parameter to specify the IP address and port of a host to which all Cisco ATA debug messages are sent. The program *prserv.exe*, which comes bundled with the Cisco ATA software, is needed to capture the debug information.

Syntax

<HOST_IP>,<HOST_PORT>

Example

If the program *prserv.exe* is running on a host with IP address 192.168.2.170 and listening port 9001, set NPrintf to 192.168.2.170.9001. This causes the Cisco ATA to send all debug traces to that IP address.

Value Type

Extended IP address

Default

0

Voice Configuration Menu Access Code

81

SyslogIP

Description

Use this parameter for diagnostic purposes; specify the IP address and port number to which the Cisco ATA should send its *syslog* output information.

The program *prserv.exe*, which is included in all Cisco ATA software upgrade packages, can be used to capture syslog information if you do not have a syslog server.

Syntax

<HOST_IPaddress>.<HOST_PORT>

Example

If you want to send syslog information to the host at IP address 192.168.2.170 and port number 514, do the following:

- Configure the value of this parameter as 192.168.2.170.514
- On your PC, run the command:

```
prserv 514
```

Value Type

Extended IP address

Default

0.0.0.0.514

Voice Configuration Menu Access Code

7975640

Related Parameter

SyslogCtrl, page 5-62

SyslogCtrl

Description

Use this parameter to turn on specific syslog traces. All traces are sent to the syslog server specified in the SyslogIP parameter.

See Table 5-9 for bit values and the corresponding types of messages to turn on for tracing.

Value Type

Bitmap

Default

0x00000000

Voice Configuration Menu Access Code

7975641

Related Parameter

SyslogIP, page 5-61

Table 5-9 SyslogCtrl Parameter Definitions

Bit Number	Type of Messages to Trace
0	ARP messages.
1	DHCP messages
2	TFTP messages
3	Cisco ATA configuration-update messages.
4	System reboot messages
5-8	Reserved.
9	Cisco ATA event messages.
10	FAX messages.
11-15	Reserved.
16	RTP statistics messages.
17-31	Reserved.

CFGID—Version Parameter for Cisco ATA Configuration File

Description

CFGID is a 32-bit unsigned-value parameter whose purpose is to allow the local administrator to track the version of the Cisco ATA configuration file. This parameter-value assignment is entirely the responsibility of the local administrator, and has no significance to the operation of the Cisco ATA.

Value Type

Bitmap

Default

0x00000000



Call Commands

This section provides detailed information on call commands for the Cisco ATA:

- Call Command Structure, page 6-1
- Syntax, page 6-2
- Call Command Example, page 6-5
- Call Command Behavior, page 6-7

Service providers can offer many supplementary services, which can be activated, configured, or deactivated in more than one way. The CallCmd parameter allows you to define the behavior of supplementary services that the Cisco ATA supports.



Note

The term *Cisco ATA* refers to both the Cisco ATA 186 and the Cisco ATA 188, unless otherwise stated.



Note

This section contains call command information for the United States and Sweden. For information about other countries, contact the Cisco equipment provider for a specific country.

Call Command Structure

The entry in the CallCmd field is a character string composed of a sequence of instructions, which consist of a combination of three elements:

- **Context**—The Cisco ATA supplementary service operation is dependent upon a state and transition process. For example, the most common state is IDLE, in which the Cisco ATA is on-hook, waiting for an incoming call. Picking up the telephone handset causes the Cisco ATA to transition to the PREDIAL state, in which the user hears a dial tone and the Cisco ATA is waiting to detect DTMF digits. The Context portion of a Call Command string specifies the state for which the commands are defined.
- **Input-Sequence**—The input sequence is simply the input from the user, a combination of hook-flash and DTMF digits.
- **Action**—This specifies the action taken by the Cisco ATA. The action depends on the Input-Sequence that the user enters and the Context in which it is entered.

Syntax

The **CallCmd** string has the following structure:

Context-Identifier Command . . . Command; . . . Context-Identifier Command;

- Table 6-1 provides a list of Context-Identifiers, which show the state of the Cisco ATA.
- **Command** consists of the following items:

Input-Sequence; Action-Identifier-1 Action-Identifier-2 [Input-Sequence]

- **Input Sequence** consists of one or more characters from the set shown in Table 6-2.
- Table 6-3 provides a list of Action Identifiers. **Action-Identifier-1** is for the first thread of a call; **Action-Identifier-2** is for the second thread of a call. Each Action Identifier is one character.

Each Context-Identifier is followed by one or more commands to allow a variable number of actions to be triggered by relevant user input commands for any state. Each command is composed of an Input-Sequence that the user enters when the Cisco ATA is in a given state and two Action-Identifier characters which define the action that the Cisco ATA performs in response to the Context-Identifier and Input-Sequence. If the Cisco ATA takes only one action, one of the two Action-Identifier characters is a null action.

Example 6-1 Syntax Example Using One Command

```
Af;AH;
```

In this simple example, the first “A” is the Context-Identifier, which means the Cisco ATA is in the CONFERENCE state, as shown in Table 6-1. The “f” is the input sequence, which is hook-flash, as shown in Table 6-2. Following the semicolon, the two action identifiers are “A” and “H”. These identifiers mean “NONE” and “Disconnect the call,” respectively, as shown in Table 6-3. Based on these action identifiers, the Cisco ATA disconnects the most recent callee, and remains connected to the first party. The state of the Cisco ATA becomes CONNECTED. Table 6-4 explains more about the various states of the Cisco ATA.

Example 6-2 Syntax Example Using Two Commands

```
CN;CAf;OF;
```

In this example, the first “C” is the Context Identifier, which means the Cisco ATA is in the PREDIAL_HOLDING state, as shown in Table 6-1. The “N” is the first input sequence, which is any part of the set of digits 0|1|2|3|4|5|6|7|8|9, as shown in Table 6-2. Following the first semicolon, the two action identifiers are “C” and “A”, which mean “Continue to Dial” and “NONE,” respectively, as shown in Table 6-3.

Following this pair of action identifiers is another input sequence, “f”, which means hook-flash, as shown in Table 6-2. Next is the semicolon, always required after the input sequence, followed by the corresponding action pair, “O” and “F”. These identifiers mean “Release the Call” and “Retrieve the Call,” respectively, as shown in Table 6-3.

Context-Identifiers

Table 6-1 Context-Identifiers

Identifier	Context (State of Cisco ATA)
A	CONFERENCE
B	PREDIAL
C	PREDIAL_HOLDING
D	CONNECTED
E	CONNECTED_HOLDING
F	CONNECTED_ALERTING
G	HOLDING
H	CONFIGURING
I	CONFIGURING_HOLDING
J	3WAYCALLING
K	CALLWAITING
L	IDLE
M	RINGING
N	DIALING
O	CALLING
P	Reserved (ANSWERING)
Q	Reserved (CANCELING)
R	Reserved (DISCONNECTING)
S	WAITHOOK
T	DIALING_HOLDING
U	CALLING_HOLDING
V	Reserved (ANSWERING_HOLDING)
W	Reserved (HOLDING_HOLDING)
X	Reserved (CANCELING_HOLDING)
Y	Reserved (DISCONNECTING_HOLDING)
Z	Reserved (HOLDING_ALERTING)
a	WAITHOOK_ALERTING
b	WAITHOOK_HOLDING

Input Sequence Identifiers

Table 6-2 *Input Sequence Identifiers*

Identifier	Input Sequence
0-9,#*	DTMF digits
f	hook flash
o	off-hook
@	anytime; for example, @f means anytime hook- flash occurs
h	on-hook
S	# *
N	0 1 2 3 4 5 6 7 8 9
D	NIS
v	a variable number (1 or more) of characters from the above list. It must be followed by a character which acts as the terminator of this variable part.

Action Identifiers

Table 6-3 *Action Identifiers*

Identifier	Action
A	NONE
B	Seizure (User intends to dial or configure)
C	Continue to dial
D	Call Return
E	Hold the active call
F	Retrieve the waiting call
G	Cancel the call attempt
H	Disconnect the call
I	Blind transfer the call to the number
N	Go to configuration mode
O	Release the call
P	Answer the incoming call
Q	Transfer with consultation
R	Say busy to the caller
a	None
b	Forward all calls to the given number

Table 6-3 Action Identifiers (continued)

c	Forward on busy to the given number
d	Forward on no answer to the given number
e	Cancel call forward
f	CLIP for the next call
g	CLIR for the next call
h	Enable Call Waiting for the next call
i	Disable Call Waiting for the next call
x	Enable Fax Mode for the next call
y	Disable Fax Mode for the next call

Call Command Example

In addition to call commands that you configure, the Cisco ATA has a default list of call commands to handle common call scenarios. Configured call commands overwrite default call commands. If any Context-Identifier or Input-Sequence elements appear in both the default Call Command string and the manually entered string, the manually entered value takes precedence.

The following string shows a sample Call Command:

```
Bf;BAN;CA;CN;CAf;OF;Df;EB;I@f;OF;H@f;OA;Lo;BAf;BA;Mo;PA;ND;CAf;OA;Of;GA;Pf;HA;Qf;OA;Rf;OA;Sf;OA;TD;CAf;OF;Uf;Gf;Vf;Hf;Wf;Ff;Xf;Af;Yf;Af;Zf;AP;bf;OF;af;OP;
```

In this section, the Call Command string is broken down into its components as follows:

```
Call Command Fragment;
  Context-Identifier
    Input-Sequence1; Action1 Action2;
    (optional) Input-Sequence2; Action1 Action2;
```



Note If you use a second input sequence, this sequence follows the Action Identifier pair without a separating semicolon.

Refer to the preceding tables to determine the meanings of the identifiers.

Example 6-3 Call Command String

```
Bf;BAN;CA;
  Predial
    hook-flash; Seizure NONE
    0|1|...|9; Continue-to-dial NONE;
CN;CAf;OF;
  Predial_Holding
    0|1|...|9; Continue-to-dial NONE
    hook-flash; Release-the-call Retrieve-the-waiting-call;
Df;EB;
  Connected
    hook-flash; Hold-the-active-call Seizure;
I@f;OF;
  Configuring_Holding
    hook-flash (at any time); Release-the-call Retrieve-the-waiting-call;
H@f;OA;
```

```

Configuring
    hook-flash (at any time); Release-the-call NONE;
Lo;BAf;BA;
    Idle
        off-hook; Seizure NONE;
        hook-flash; Seizure NONE;
Mo;PA;
    Ringing
        off-hook; Answer-the-incoming-call NONE;
ND;CAf;OA
    Dialing
        0|1|...|9|#|*; Continue-to-dial NONE
        hook-flash; Release-the-call NONE;
Of;GA;
    Calling
        hook-flash; Cancel-the-call-attempt NONE;
Pf;HA;
    Answering
        hook-flash; Disconnect-the-call NONE;
Qf;OA;
    Canceling
        hook-flash; Release-the-call NONE;
Rf;OA;
    Disconnecting
        hook-flash; Release-the-call NONE;
Sf;OA;
    Waithook
        hook-flash; Release-the-call NONE;
TD;CAf;OF;
    Dialing_Holding
        0|1|...|9|#|*; Continue-to-dial NONE;
        hook-flash; Release-the-call NONE;
Uf;GF;
    Calling_Holding
        hook-flash; Cancel-the-call-attempt Retrieve-the-waiting-call;
Vf;HF;
    Answering_Holding
        hook-flash; Disconnect-the-call Retrieve-the-waiting-call;
Wf;FF;
    Holding_Holding
        hook-flash; Retrieve-the-waiting-call Retrieve-the-waiting-call;
Xf;AF;
    Canceling_Holding
        hook-flash; NONE Retrieve-the-waiting-call;
Yf;AF;
    Disconnecting_Holding
        hook-flash; NONE Retrieve-the-waiting-call;
Zf;AP;
    Holding_Alerting
        hook-flash; NONE Answering;
bf;OF;
    Waithook_Holding
        hook-flash; Release-the-call Retrieve-the-waiting-call;
af;OP;
    Waithook_Holding
        hook-flash; Release-the-call Answer-the-incoming-call;

```

Call Command Behavior

Table 6-4 summarizes differing Call Command behavior based on the U.S. and Sweden default call commands.

U.S. Call Command Default

Af;AH;BS;NA;CS;NA;Df;EB;Ff;EP;Kf;EFh;HH;Jf;AFh;HQ;I*67;gA*82;fA#90v#;OI;H#72v#;bA#74v#;cA#75v#;dA#73;eA*67;gA*82;fA*70;iA*69;DA*99;xA;Uh;GQ;

Sweden Call Command Default

BS;NA;CS;NA;Df;EB;Ff0;ARf1;HPf2;EPf3;AP;Kf1;HFf2;EFf3;AFf4;HQh;HH;Jf1;HFf2;EFf3;AFf4;HQ;Af4;HQ;I*31#;gA#31#;gA*90*v#;OI;H*21*v#;bA*61*v#;dA*67*v#;cA#21#;eA#61#;eA#67#;eA*31#;gA#31#;gA*43#;hA#43#;iA*69#;DA*99#;xA;Uh;GQ;

Table Notations

The following notations are used in Table 6-4:

- FE—Far end
- AFE—Active Far End, which is a connected far end that is not placed on hold
- WFE—Waiting Far End, which is a connected far end being placed on hold, or an incoming caller waiting to be answered
- R—Hook Flash
- ONH—On Hook
- OFH—Off Hook
- 0-9,*,#—DTMF digits
- v—a variable length string, usually a phone number, and does not include #
- CWT—call-waiting tone



Note

The notations in Table 6-4 include abbreviations for input sequence behavior. Refer to the tables and syntax examples shown earlier in this section. The Summary of Commands column in Table 6-4 is based on the actual command syntax used in the default Call Command strings for the United States and Sweden.

Table 6-4 Call Command Behavior

Cisco ATA State and its Definition	Summary of Commands (Input Sequence and Actions)
IDLE: Phone is on-hook; Cisco ATA is waiting for incoming call	<ul style="list-style-type: none"> • OFH—Start dial tone and go to PREDIAL state. • New incoming call or a waiting call (started before it enters IDLE)—Start ringing the phone and go to the RINGING state.
PREDIAL: Phone just went off-hook but no DTMF has been entered yet; Cisco ATA plays dial-tone	United States and Sweden: <ul style="list-style-type: none"> • # , *—Stop dial-tone, go to the CONFIG state, and prepare to accept a complete configuration sequence. • 0-9: Stop dial tone, start invoking dial-plan rules, and go to the DIALING state to accept a complete phone number.

Table 6-4 Call Command Behavior (continued)

Cisco ATA State and its Definition	Summary of Commands (Input Sequence and Actions)
DIALING: User is entering phone number, which is parsed with the given dial-plan rules	<ul style="list-style-type: none"> • R—Abort dialing, restart dial tone, and revert to PREDIAL state. • Invalid phone number—Abort dialing, plays fast-busy, and go to WAITHOOK state.
CONFIG: User configuring a supplementary service in the United States	<ul style="list-style-type: none"> • *69—Call Return • #72v#—Forward unconditional to number specified in 'v' (PacBell use 72#). • #73—Cancel any call forwarding (PacBell use 73#). • #74v#—Forward on busy to number specified in 'v' (PacBell does not enable this service from the phone). • #75v#—Forward on no answer to number specified in 'v' (Pac Bell does not enable this service from the phone). • *67—CLIR in the next call (if global profile is CLIP) • *82—CLIP for the next call (if global user profile is CLIR) • *70—Disable call waiting in the next call. • *99—Enable Fax Mode in the next call (non-standard). • Dial-tone—Revert to PREDIAL state. • Any complete configuration sequence—Carry out the configuration command, restart dial-tone, and revert to PREDIAL state.
CONFIG: User configuring a supplementary service in Sweden	<ul style="list-style-type: none"> • *21*v#—Forward unconditionally to number specified in 'v'. • *67*v#—Forward on busy to number specified in 'v'. • *61*v#—Forward on no answer to number specified in 'v'. • #21#—Cancel any call forwarding. • #67#—Cancel any call forwarding. • #61#—Cancel any call forwarding. • #31#—CLIR in the next call. • *31#—CLIR in the next call. • *43#—Enable call waiting in the next call (Sweden allows globally disable call waiting). • #43#—Disable call waiting in the next call. • *69#—Call Return • (non-standard)*99#—Enable Fax Mode in the next call (non-standard). <p>All Regions:</p> <ul style="list-style-type: none"> • R or any unrecognized sequence—Abort configuration, restart dial tone and revert to PREDIAL state. • Any complete configuration sequence—Carry out the configuration command, restart dial tone, and revert to PREDIAL state.

Table 6-4 Call Command Behavior (continued)

Cisco ATA State and its Definition	Summary of Commands (Input Sequence and Actions)
CALLING: Phone number is sent; Cisco ATA is waiting for response from the far end	<ul style="list-style-type: none"> R—Cancel the outgoing call, restarts dial-tone, and revert to PREDIAL state.
RINGING: Cisco ATA is ringing the phone to alert user of an incoming call	<ul style="list-style-type: none"> OFH—Stop ringing, answer the call, and go to CONNECTED state.
CONNECTED: The Cisco ATA is connected with one far end party; Cisco ATA may be the caller or the callee	United States and Sweden: <ul style="list-style-type: none"> R—Hold current call, play dial-tone to dial second number, and go to PREDIAL_HOLDING state.
WAITHOOK: Far end hangs up while in CONNECTED state; Cisco ATA plays fast-busy after five seconds in this state	<ul style="list-style-type: none"> R—Stop fast-busy, start dial-tone, and go to PREDIAL state.
CONNECTED_ALERTING: Cisco ATA receives another call while in CONNECTED state; Cisco ATA plays Call Waiting tone periodically (every 10 seconds for US; every second for Sweden)	United States: <ul style="list-style-type: none"> R—Place current call on-hold, answer the waiting call, and go to CALLWAITING state. Sweden: <ul style="list-style-type: none"> R0—Continue current call, reject the waiting call, and revert to CONNECTED state. R1—Disconnect current call, answer the waiting call, and go to CONNECTED state. R2—Place current call on-hold, answer waiting call, and go to CALLWAITING state. R3—Continue with current call, answer the waiting call and go to CONFERENCE state. All Regions: <ul style="list-style-type: none"> ONH—Disconnect current call and go to IDLE state (the Cisco ATA then automatically starts ringing the phone, and goes to RINGING state). AFE hangs up—Go to WAITHOOK_ALERTING state, continue to play CWT. WFE cancels the call—Stop CWT and revert to CONNECTED state.
CALL WAITING: Cisco ATA is connected to two far end users on the same line; one is in active conversation (the active far end or AFE) while the other is on-hold (the waiting far end or WFE). This state is initially entered when the Cisco ATA is connected to one of the far ends while the other far end calls into the Cisco ATA.	United States: <ul style="list-style-type: none"> R—Place the AFE on-hold and retrieve the WFE. ONH—Transfer the WFE to the AFE, drop out of the call, and go to PREDIAL state. Sweden: <ul style="list-style-type: none"> R1—Disconnect current call, answer the waiting call, and go to CONNECTED state. R2—Place the AFE on-hold and retrieve the WFE. R3—Retrieve the WFE, and go to CONFERENCE state. R4—Transfer the WFE to the AFE, drop out of the call, and go to PREDIAL state.

Table 6-4 Call Command Behavior (continued)

Cisco ATA State and its Definition	Summary of Commands (Input Sequence and Actions)
<p>3WAYCALLING: Cisco ATA is connected to two far end users on the same line; one of them is in active conversation (the active far end or AFE) while the other is on-hold (the waiting far end or WFE). This state is initially entered when the Cisco ATA is connected to one of the far ends, then places this far end on hold and calls the second far end.</p>	<p>United States:</p> <ul style="list-style-type: none"> • R—Retrieve the WFE and go to CONFERENCE state. • ONH—The default behavior is to disconnect both the current call and the held call, then go to the PREDIAL state. <p>The enhanced behavior (with the call-waiting hang-up alert feature enabled) is to disconnect the current call, retrieve the held call, go to the CONNECTED state, then alert the user of the call on hold by ringing the phone.</p> <p>Sweden:</p> <ul style="list-style-type: none"> • Same as for CALLWAITING state
<p>CONFERENCE: Cisco ATA is connected to two active far ends simultaneously; Cisco ATA performs audio mixing such that every party can hear the other two parties but not themselves.</p>	<p>United States:</p> <ul style="list-style-type: none"> • R—Disconnect the last callee and stay connected with the first party, and revert to CONNECTED state. <p>Sweden:</p> <ul style="list-style-type: none"> • R4—Transfer one FE to the other, drop out of the call, and go to PREDIAL state.
<p>PREDIAL_HOLDING: Cisco ATA user places a connected call on-hold and prepares to dial a second number; Cisco ATA plays dial-tone.</p>	<p>United States and Sweden:</p> <ul style="list-style-type: none"> • *,#—Stop dial-tone, go to CONFIG_HOLDING state, and prepare to collect a configuration command. • 0-9—Stop dial-tone, go to DIALING_HOLDING state, and prepare to complete dialing a second phone number. <p>All Regions:</p> <ul style="list-style-type: none"> • Stop dial-tone, retrieve the WFE, and revert to CONNECTED state.
<p>CONFIG_HOLDING: A connected FE is placed on hold, while the Cisco ATA is entering a configuration command.</p>	<p>United States:</p> <ul style="list-style-type: none"> • *67—CLIR for the next call • *82—CLIP for the next call • #90v#—Blind transfer to the number specified in 'v'; disconnect the call and go to PREDIAL state. <p>Sweden:</p> <ul style="list-style-type: none"> • #31# or *31#—CLIR in the next call • *90*v#—Blind transfer to the number specified in 'v'; disconnect the call and go to PREDIAL (non-standard) state. <p>All Regions:</p> <ul style="list-style-type: none"> • R or any unrecognized sequence—Abort configuration, restart dial tone, and go to PREDIAL_HOLDING state. • A complete configuration sequence—Carry out the command, and go to PREDIAL_HOLDING state.

Table 6-4 Call Command Behavior (continued)

Cisco ATA State and its Definition	Summary of Commands (Input Sequence and Actions)
DIALING_HOLDING: Cisco ATA user is entering a second phone number to call while placing a connected call on hold	<ul style="list-style-type: none"> • Collected digits match a dial-plan rule—Call the new number, and go to CALLING_HOLDING state • R—Abort dialing and revert to PREDIAL_HOLDING state.
CALLING_HOLDING: Cisco ATA is waiting for a second far end to respond while placing a connected call on hold	<ul style="list-style-type: none"> • R—Cancel the call and revert to PREDIAL_HOLDING state. • ONH—Cancel the call and transfer the waiting party to the callee, and revert back to PREDIAL state.
WAITHOOK_HOLDING: The AFE hangs-up to disconnect the current call while there is a WFE being put on hold	<ul style="list-style-type: none"> • R—Retrieve the WFE and go to CONNECTED state.
AITHOOK_ALERTING: The AFE hangs up while a waiting call alerts	<ul style="list-style-type: none"> • R—Stop CWT, answer the waiting call, and go to CONNECTED state. • WFE: Cancel the call; stop CWT, go to WAITHOOK state. • ONH—Go to IDLE state (in which Cisco ATA automatically starts ringing the phone, and goes to RINGING state).



Configuring and Debugging Fax Services

The Cisco ATA provides two modes of fax services that are capable of internetworking with Cisco IOS gateways over IP networks. These modes are called *fax pass-through mode* and *fax mode*.

With *fax pass-through mode*, the Cisco ATA encodes fax traffic within the G.711 voice codec and passes it through the Voice Over IP (VoIP) network as though the fax were a voice call. This mode uses the Cisco proprietary *fax upspeed* method.

With *fax mode*, the Cisco ATA presents itself as a device capable of using only G.711 codecs; therefore, no codec renegotiation or switchover is required. This places minimum functionality and configuration requirements on remote gateways. *Fax mode* is recommended for environments in which G.711 fax upspeed is not available for the supporting Cisco gateways.

This section contains the following topics:

- Using Fax Pass-through Mode, page 7-1
- Using FAX Mode, page 7-6
- Debugging the Cisco ATA 186/188 Fax Services, page 7-7



Note

The term *Cisco ATA* is used throughout this manual to refer to both the Cisco ATA 186 and the Cisco ATA 188, unless differences between the Cisco ATA 186 and Cisco ATA 188 are explicitly stated.

Using Fax Pass-through Mode

Fax pass-through mode allows for maximum codec flexibility because users may set up a voice call using any voice codec, then renegotiate to a G.711 codec for the fax session. To use *fax pass-through mode*, first configure the Cisco ATA and supporting Cisco gateways to support the Cisco-proprietary G.711 fax upspeed method. Then, disable fax relay on the far-end gateway—either for the entire gateway or for the dial peer engaged in the fax call with the Cisco ATA.

The fax upspeed method allows you to use low bit-rate codecs such as G.723 and G.729 for voice calls, and G.711 codecs for fax calls. With a fax call, the Cisco ATA detects a 2100-Hz CED tone or V.21 preamble flag, then informs the remote gateway of its intent to switchover to G.711 via a peer-to-peer message. This type of message, carried as a Named Signaling Event (NSE) within the RTP stream, is used for all fax event signaling. The Cisco ATA can initiate and respond to NSEs and can function as either an originating or terminating gateway.

**Note**

The Cisco ATA can also accept standard-based protocol-level codec switch requests, but cannot send such requests. Therefore, to interoperate with a Cisco gateway, use the Cisco-proprietary codec switch.

This section contains the following topics:

- Configuring the Cisco ATA for Fax Pass-through mode, page 7-2
- Configuring Cisco IOS Gateways to Enable Fax Pass-through, page 7-3

Configuring the Cisco ATA for Fax Pass-through mode

Fax Pass-through mode requires configuring two configuration parameters:

AudioMode, page 7-2

ConnectMode, page 7-3

AudioMode

Description

The AudioMode parameter is a 32-bit value. The lower 16 bits apply to the **Phone 1** port of the Cisco ATA and the upper 16 bits apply to the **Phone 2** port of the Cisco ATA.

Example

The following is an example of configuring the **Phone 1** port of the Cisco ATA for *fax pass-through mode*:

```
0xxxxx0015
```

Translation

This setting translates to the following bitmap:

```
xxxx xxxx xxxx xxxx 0000 0000 0001 0101
```

- Bit 0 = 1—Enables G.711 silence suppression (VAD)
- Bit 2 = 1—Enables Fax CED tone detection and switchover upon detection
- Bit 4 = 1, Bit 5 = 0—DTMF transmission method = out-of-band through negotiation
- Bit 6 = Bit 7 = 0—Hookflash transmission method = disable sending out hookflash

**Note**

The values xxxx in the example apply to the **Phone 2** port of the Cisco ATA.

To configure the same value for the **Phone 2** port of the Cisco ATA, the value would be 0x0015xxxx. The configuration of one port is independent from the configuration of the other port.

ConnectMode

Description

The ConnectMode parameter is a 32-bit value. The parameter settings apply to both lines of the Cisco ATA. Configure ConnectMode after configuring AudioMode for *fax pass-through mode*. Cisco recommends you use the following ConnectMode setting to interoperate with a Cisco IOS gateway.

Recommended Setting

```
0x90000400
```

Translation

This setting translates to the bitmap:

```
1001 0000 0000 0000 0000 0100 0000 0000
```

Bit 2 and bits 7 through 15 are the only relevant bits for *fax pass-through mode*. These bits from the example are isolated below:

```
xxxx xxxx xxxx xxxx 0000 0100 0xxx x0xx
```

- Bit 2 = 0—Uses RTP payload number 126/127 for fax upspeed to G.711 μ -law/G.711A-law. Set this value to 1 if you want to use RTP payload number 0/8 for fax upspeed.
- Bit 7 = 0—Disables fax pass-through redundancy. Set this bit to 1 to enable redundancy. With redundancy enabled, the Cisco ATA sends each packet twice. Because of bandwidth and transmission time costs, use this option only if network quality is poor and all other gateways used in the network support this feature.
- Bits {12, 11, 10, 9, 8} = {0, 0, 1, 0, 0}—Sets the offset to NSE payload-type number 96 to 4. Setting the offset to 4 results in the Cisco ATA sending an NSE payload-type value of 100 by default. Valid offset values range from 2 to 23 (NSE payload type value of 98 to 119). Set this value to match the value for your Cisco gateways.
Most Cisco MGCP-based gateways, such as Cisco 6608, use NSE payload type 101 by default. Most Cisco H.323/SIP-based gateways use NSE payload type 100 by default.
- Bit 13 = 0—Uses G.711 μ -law for fax pass-through upspeed. Set this bit to 1 to use G.711A for fax pass-through upspeed.
- Bit 14 = Bit 15 = 0—Enables *fax pass-through mode* using the Cisco proprietary method (recommended). Set both of these bits to 1 to disable *fax pass-through mode*.

Configuring Cisco IOS Gateways to Enable Fax Pass-through

To configure your IOS gateways to network with Cisco ATA, do the following:

Procedure

-
- Step 1** Enable Fax Pass-through Mode, page 7-4
- Step 2** Disable Fax Relay Feature, page 7-5
-

**Note**

For detailed information on setting up your IOS gateways and on feature availability, refer to the document *Cisco Fax Services over IP*.

Enable Fax Pass-through Mode

The supporting Cisco gateway can enable *fax pass-through mode* using system-level or dial-peer-level commands.

System Level commands

Enable the fax pass-through feature using the following system-level commands:

Procedure

Step 1 Run the following command:

```
voice service voip
```

Step 2 Run the following command:

```
modem passthrough NSE [payload-type number] codec {g711μ-law | g711alaw} [redundancy] [maximum-sessions value]
```

The definitions of the command parameters are as follows:

- The **payload-type** parameter default is 100. Valid values are from 98 to 119.
The NSE payload number must be the same on both the Cisco ATA and the Cisco gateway.
- The **codec** parameter must be G.711μ-law for faxes sent over a T1 trunk or G.711A-law for faxes sent over an E1 trunk.
- The **redundancy** parameter enables RFC 2198 packet redundancy. It is disabled by default.
- The **maximum sessions** parameter defines the number of simultaneous fax pass-through calls with redundancy. The default is 16. Valid values are 1 to 26.

Step 3 For the Cisco ATA ConnectMode parameter, turn off bits 14 and 15. This enables the sending of fax pass-through signals and the detection of incoming fax pass-through signals using the Cisco proprietary method.

**Note**

The NSE payload-type number, fax pass-through codec (G.711μ-law or G.711A-law) and redundancy parameters must have the same settings for the Cisco ATA that they have for supporting Cisco gateways.

Dial-Peer Level Commands

You can enable *fax pass-through mode* for communication between a Cisco IOS gateway and the specified Cisco ATA using the following dial-peer level commands:

Procedure

- Step 1** Perform the command:
dial-peer voice *tag* voip
- Step 2** Perform the command:
modem passthrough {NSE [payload-type *number*] codec {g711µlaw | g711alaw} [redundancy] | system}
- a. The default of this command is:
modem passthrough system
- When using the default configuration, the dial-peer fax pass-through configuration is defined by the **voice service voip** command. When the **system** option is used, no other parameters are available.
- When the NSE is configured in the fax pass-through command at the dial-peer level, the fax pass-through definition in the **dial-peer** command takes priority over the definition in the **voice service voip** command.
- b. The **payload-type *number***, **codec**, and **redundancy** parameters can also be used.
- For example, the command:
modem passthrough NSE codec g711µlaw
- means that the Cisco ATA will use the NSE payload-type number 100, G.711µ-law codec, and no redundancy in *fax pass-through mode*.
- Step 3** When setting up dial-peer for fax pass-through, it is necessary to set up a pair of dial-peers for inbound and outbound calls between the Cisco ATA and Cisco IOS gateways. You do this by specifying the **destination-pattern** and **incoming-called number**. The **destination-pattern** should point to the Cisco ATA, while the incoming-called number should apply to all numbers that the Cisco ATA is allowed to dial.
-

Disable Fax Relay Feature

Fax relay may be enabled by default for some IOS gateways. If you do not disable the fax relay feature, it may override the precedence of fax/modem pass-through and cause the fax transmission to fail. It is necessary to disable fax relay at the dial-peer or system level with the following command:

fax rate disable

Using FAX Mode

Use *fax mode* when the gateways in the network do not support *fax pass-through mode* or dial-peer configuration.

You can set one or both lines of the Cisco ATA to G.711-only *fax mode*. This mode allows the fax machine connected to the Cisco ATA to communicate directly with the far endpoint with no fax signaling event occurring between the two gateways.

This section contains the following topics:

- Configuring the Cisco ATA for Fax Mode, page 7-6
- Configuring the Cisco ATA for Fax Mode on a Per-Call Basis, page 7-7
- Configuring the Cisco IOS Gateway for Fax Mode, page 7-7

Configuring the Cisco ATA for Fax Mode

G.711-only *fax mode* operation requires configuration of one parameter—**AudioMode**.

Description

The AudioMode parameter is a 32-bit value. The lower 16 bits apply to the **Phone 1** port of the Cisco ATA, and the upper 16 bits to the **Phone 2** port. The following is an example of the **Phone 1** port of the Cisco ATA configured for G.711-only *fax mode*:

Example

```
0xXXXX0012
```

Translation

This setting translates to the bitmap:

```
xxxx xxxx xxxx xxxx 0000 0000 0001 0010
```

- Bit 0 = 0—Disables G.711 silence suppression (VAD).
- Bit 1 = 1—Uses G.711 only, does not user the low bit-rate codec.
- Bit 2 = 0—Disables Fax CED tone detection.
- Bit 4 = 1, Bit 5 = 0—DTMF transmission method: out-of-band through negotiation
- Bit 6 = Bit 7 = 0—Hookflash transmission method: disables sending out hookflash



Note

The values xxxx in the example do not apply to the **Phone 1** port of the Cisco ATA.

To configure the same value for the **Phone 2** port of the Cisco ATA, the value would be 0x0012XXXX. The configuration of one port is independent from the configuration of the other port.



Note

The AudioMode configuration overrides the values of the following three parameters: RxCodec, TxCodec, and LBRCodec. For example, if these three parameters are each set to 0 (for G.723), the Cisco ATA would still use G.711 if AudioMode is set to 0x00120012. With this configuration, the Cisco ATA sends both G.711μ-law and G.711A-law as preferred codecs to a peer voice gateway.

Configuring the Cisco ATA for Fax Mode on a Per-Call Basis



Note The per-call-basis *fax mode* feature is only available for the H.323 and SIP protocols.

If you want to activate *fax mode* on a per-call basis, configure the following parameters:

Procedure

-
- Step 1** **CallFeatures** and **PaidFeatures** Bit 15 (for line1—mask 0x8000) and Bit 31 (for line2—mask 0x80000000) = 1: This sets the default to enable *fax mode* on a per-call basis.
- Step 2** **AudioMode** Bit 2 = 0: This disables fax CED tone detection.
- Step 3** **CallCmd** includes ***99;xA** (99 is the default; the value can be changed to any prefix code.)
-

To activate a call from your fax machine, enter ***99** (default), then enter the telephone number to which you want to send the fax. The next call will automatically revert to normal mode.

Configuring the Cisco IOS Gateway for Fax Mode

On the Cisco gateway, disable both fax relay and fax pass-through at the dial-peer level or system level with the following commands:

Procedure

-
- Step 1** Run the command:
fax rate disable
- Step 2** Run the command:
no modem passthrough
-

Debugging the Cisco ATA 186/188 Fax Services

This section includes the following debugging topics for fax services:

- Common Problems When Using IOS Gateways, page 7-7
- Using prserv for Diagnosing Fax Problems, page 7-9
- Using rtpcatch for Diagnosing Fax Problems, page 7-12

Common Problems When Using IOS Gateways

Table 7-1 lists typical problems and actions that might solve these problems for situations in which the Cisco ATA is using fax over a Cisco IOS gateway.

Table 7-1 Solving Common Fax Problems

Problem	Action
The far-end gateway is not loaded with correct software image.	Cisco recommends IOS version 12.2 (11)T or higher for the Cisco 2600 and Cisco 3600, and IOS version 12.1 (3)T or higher for Cisco AS5300. The Cisco 6608 supports both the NSE and NTE methods of <i>fax pass-through mode</i> , beginning with software version D004030145S16608. To use <i>fax pass-through mode</i> with the Cisco 6608, the user must select 6608 NSE mode, and the NSE payload type must be reconfigured to match the Cisco ATA.
The Cisco IOS gateway is not configured using the external T1 clock.	Perform these steps: 1. Enter the following CLI commands: Controller T1 0 clock source line 2. On the Cisco CallManager Gateway Configuration page, choose the T1 line connection port. Set the clock as “external primary.”
The Cisco ATA is not loaded with the proper software.	Cisco recommends using software version 2.14 or higher.
User is operating Cisco ATA software on an outdated model.	Cisco recommends using Cisco ATA models 186-I1, 186-I2, 188-I1, or 188-I2 (hardware platforms).
The Cisco ATA is not configured for <i>fax mode</i> or <i>fax pass-through mode</i> .	For <i>fax mode</i> , the AudioMode configuration parameter should be set to 0xXXXX0012 (X = value not applicable) for the Phone 1 port of the Cisco ATA, and 0x0012XXXX for the Phone 2 port. For <i>fax pass-through mode</i> , AudioMode should be set to 0xXXXX0015 for the Phone 1 port of the Cisco ATA, and 0x0015XXXX for the Phone 2 port.
The remote gateway is not configured for modem/ <i>fax pass-through mode</i> .	When the Cisco ATA is configured for <i>fax pass-through mode</i> , all remote gateways must be configured with modem/ <i>fax pass-through mode</i> either on a dial-peer level or system level.
Fax relay is not disabled on the remote gateway.	Fax relay is enabled by default on some Cisco gateways. When fax relay is enabled, it can override <i>fax pass-through mode</i> and cause fax failure. Examples of the CLI commands to disable fax relay for IOS gateways are as follows: • fax rate disable for H.323/SIP gateways • mgcp fax t38 inhibit for MGCP gateways

Table 7-1 Solving Common Fax Problems (continued)

Problem	Action
Fax/modem pass-through method on the remote gateway is not compatible with the Cisco NSE-based method.	Some Cisco gateways (such as Cisco VG248, and Cisco 6608) may use signaling messages based on RFC2833 for G.711 upspeed when loaded with older software images. This method is incompatible with the Cisco NSE-based method. You must check to make sure that the image on your gateway supports the Cisco NSE-based fax/modem pass-through. Otherwise, you must configure the Cisco ATA to use <i>fax mode</i> .
NSE payload types differ between gateways.	The Cisco ATA has a configurable NSE packet payload-type value whose default is 100. This value is compatible with the implementations of most Cisco gateways. However, some Cisco gateways use 101 as the NSE payload type. Ensure that all gateways in your environment use the same NSE payload type if you wish to successfully use <i>fax pass-through mode</i> .

Using prserv for Diagnosing Fax Problems

This section contains the following topics:

- prserv Overview, page 7-9
- Analyzing prserv Output for Fax Sessions, page 7-10

prserv Overview

prserv is a tool that runs on a Microsoft Windows-based PC and serves as a log server that captures debug information that the Cisco ATA sends to your PC IP address/port. The debug information is saved into a readable text file.

To enable your Cisco ATA to send debug information, you need to set the **Nprintf** configuration parameter to your PC IP address and an available port, as shown in the following procedure:

Procedure

Step 1

<IP address>.<port>

<IP address> is the IP address of your PC.

<port> is any unused port (any number from 1024 to 65535) on your PC.



Note

You can the Nprintf parameter on the Cisco ATA configuration web page or with the TFTP-based configuration method.

Step 2

To operate the debug capture program prserv.exe, place the prserv program in a folder on your PC. At the DOS prompt, enter:

```
C:>prserv <port>
```

<port> is the port number you have selected. If <port> is omitted, the default port number is 9001.

As `prserv` receives debug information from the Cisco ATA, it displays the information on the DOS screen and saves it to the output file `<port>.log`.

Once you are finished capturing debug information, you can stop `prserv` by entering Ctrl-C at the DOS prompt. If you restart the process without changing the name of the log file, any new debug information is appended to the end of the original file.

Analyzing `prserv` Output for Fax Sessions

The debug log obtained from `prserv` is for detecting simple configuration problems.



Note

A comprehensive understanding of the fax events requires the use of the `rtptcatch` tool (see the “Using `rtptcatch` for Diagnosing Fax Problems” section on page 7-12).

Table 7-2 lists log events relevant to analyzing a fax session.

Table 7-2 Debug Log Examples

Log event	Description
<code>[ch] Enable encoder <pt></code>	Voice encoder type <code>pt</code> is enabled for the channel <code>ch</code> , where <code>pt</code> can be 0 for G.711 μ -law, 4 for G.723.1, 8 for G.711A-law, and 18 for G.729. For example, <code>[0]Enable encoder 4</code> indicates that the Cisco ATA transmitted G.723.1-encoded voice packets.
<code>[ch] DPKT 1st: <timestamp1> <timestamp2>, pt <pt></code>	The first voice packet that the Cisco ATA received was of RTP payload type <code>pt</code> for the channel <code>ch</code> with timestamp of <code>timestamp1</code> , and the local decoding timestamp was set to <code>timestamp2</code> . For example, <code>[0]DPKT 1st: 1491513359 1491512639, pt 4</code> indicates that the first RTP packet that the Cisco ATA received was G.723.1-encoded for channel 0.
<code>[ch] codec: <pt1> => <pt2></code>	Voice codec switchover occurred. The voice encoder type switched from <code>pt1</code> to <code>pt2</code> for the channel <code>ch</code> . For example, <code>[0]codec: 4 => 0</code> indicates that the local voice encoder on the Cisco ATA switched from G.723.1 to G.711 μ -law.
<code>[ch] Rx MPT PT=<NSEpt> NSE pkt <event></code>	Channel <code>ch</code> received an NSE packet of <code>event</code> with payload type of <code>NSEpt</code> . For <code>event</code> , <code>c0XXXXXX</code> indicates a CED tone event, and <code>c1XXXXXX</code> indicates a phase reversal event. For example, <code>[0]Rx MPT PT=100 NSE pkt c0000000</code> indicates that the Cisco ATA received a CED tone event NSE packet with payload type of 100.
<code>[ch] Tx MPT PT=<pt> NSE pkt <event></code>	Channel <code>ch</code> transmitted an NSE packet of <code>event</code> with payload type of <code>NSEpt</code> . For <code>event</code> , <code>c0XXXXXX</code> indicates a CED tone event, and <code>c1XXXXXX</code> indicates a phase reversal event. For example, <code>[0]Tx MPT PT=100 NSE pkt c0000000</code> indicates that the ATA transmitted a CED tone event NSE packet with payload type of 100.

Debugging FAX Pass-through Mode

When the Cisco ATA is configured to use *fax pass-through mode*, the fax call session can be established with an arbitrary voice codec. Once the voice call has been established, fax machines can signal their presence by means of a CED tone or V.21 preamble flag, after which the gateways send NSE packets to initiate switchover.



Note

For *fax pass-through mode*, check the Cisco ATA debug log to verify that it is acting as an originating gateway as well as a terminating gateway.

Terminating-Gateway Example

When the Cisco ATA is used as a terminating gateway for a fax session, make sure the following conditions are true:

- The Cisco ATA transmits CED-tone-event NSE packets.
- The encoder switchover to G.711 occurs during the NSE-packet transaction.

An example debug log for a terminating gateway scenario is show below:

```
[0]Tx MPT PT=100 NSE pkt c0000000
[0]codec: 4 => 0
[0]Rx MPT PT=100 NSE pkt c0000000
```



Note

The NSE response to the CED tone event is not mandatory; some gateways may not send back an NSE response.

Originating-Gateway Example

When the Cisco ATA is used as an originating gateway for a fax session, make sure that the following conditions are true:

- The Cisco ATA receives and responds to CED-tone-event NSE packets.
- The NSE payload type is the same for the received and transmitted NSE packets.
- The encoder switchover to G.711 occurs during NSE-packet transaction.

An example debug log for an originating gateway scenario is shown below:

```
[0]Rx MPT PT=100 NSE pkt c0000000
[0]Tx MPT PT=100 NSE pkt c0000000
[0]codec: 4 => 0
[0]Rx MPT PT=100 NSE pkt c0000000
[0]Rx MPT PT=100 NSE pkt c0000000
```



Note

If your gateway is using a legacy IOS software image, it may not send NSE packets but instead may rely on a straightforward codec switchover mechanism. In this case, a codec switchover event occurs rather than an NSE packet transaction.

Possible Reasons for Failure

If your Cisco ATA does not receive CED-tone-event NSE packets and codec switchover does not occur, the failure may be due to the following reasons:

- The terminating gateway is not configured with fax/modem pass-through.

- The *fax pass-through mode* used by the terminating gateway may not be compatible with the Cisco NSE method.

If the log shows proper NSE packet transaction and G.711 upspeed for your fax session but the session still fails, check that the following conditions are true:

- The Cisco ATA software image version is 2.14 or above.
- The Cisco ATA model number is ATA186-I1, ATA186-I2, ATA188-I1, or ATA188-I2.
- The fax relay option for the remote gateways has been disabled.

Debugging FAX Mode

When the Cisco ATA is configured with *fax mode*, only G.711 codecs are used. You must confirm that only 0 (for G.711 μ -law) or 8 (for G.711A-law) appear in the `Enable encoder` and `DPKT 1st` debug lines. The following example of a debug log shows that G.711 μ -law is used:

```
[0]Enable encoder 0
[0]DPKT 1st: 1491513359 1491512639, pt 0
```

If the numeric codes for the G.711 codecs do not appear in the log, you need to check your **AudioMode** parameter setting on the Cisco ATA.

If the correct G.711 codecs appear in the log but your fax sessions still fail, check that the following conditions are true:

- The Cisco ATA software image version is 2.14 or above.
- The Cisco ATA model number is ATA186-I1, ATA186-I2, ATA 188-I1, or ATA188-I2.
- The fax relay option for the remote gateways has been disabled.

Using rtpcatch for Diagnosing Fax Problems

This section contains the following topics:

- `rtpcatch` Overview, page 7-12
- Example of `rtpcatch`, page 7-14
- Analyzing `rtpcatch` Output for Fax Sessions, page 7-16
- Using `rtpcatch` to Analyze Common Causes of Failure, page 7-18
- `rtpcatch` Limitations, page 7-20

rtpcatch Overview

rtpcatch is a tool that provides comprehensive information for a VoIP connection. The tool runs on a Microsoft Windows-based PC and is capable of parsing an output capture file from Network Associates (NAI) Sniffer Pro and identifies significant fax pass-through and fax relay events.

Major functions

rtpcatch includes the following major functions:

- Reads session data from Sniffer Pro capture files.
- Analyzes media streams.

- Stores media streams to files.
- Reports RTP statistics such as the number of RTP packets, the number of RTP frames, the number of lost packets, the number of filler packets during silence suppression periods, and the number of erased packets.

How to Use

To use **rtppatch**, follow these steps:

Procedure

-
- Step 1** Create a working directory for **rtppatch** and place the executable file `rtppatch.exe` in this directory.
- Step 2** Copy your Network Associates Sniffer Pro capture files into this directory.
- Step 3** At the DOS prompt of this directory, enter the following command:
- ```
:>rtppatch <cap_file> [<prefix>] [options]
```
- **<cap\_file>** is the NAI Sniffer capture file.
  - **<prefix>** is the prefix prepended to the output filenames.
- 

## Output Files

The output files of **rtppatch** include a summary file and audio stream files.

The summary file is `<prefix>.sum` if **<prefix>** is specified, otherwise it is `file.sum`.

Stream files are labeled with an integer tag beginning with 00. Stream files are also tagged with the extension *pcm* for G.711A/G.711 $\mu$ -law, *723* for G723.1, *729* for G729, *t38* for T.38, and *cfr* for Cisco Fax Relay.

## Options

**rtppatch** options include:

- `-fax`—to output the fax events for a connection.

The output includes "FAX summary 1" as the interleaved event list for all directions, and "FAX summary 2" as the event list for each direction. The reported events include voice codec change, NSE signalling, and fax relay events.

- `-port <port0> <port1>`—to discard any packets sent from/to this port.

If the NAI Sniffer capture file includes Cisco ATA **prserv** packets, these packets can interfere with **rtppatch** analysis. Some **prserv** packets might be interpreted as NTE or NSE events. To prevent such interference, you can either disable debugging output on the Cisco ATA (do this by setting the **Nprintf** configuration parameter to 0), configure your NAI Sniffer to filter out the **prserv** packets, or run **rtppatch** with the `-port` options.



### Note

**rtppatch** works best for analyzing a single VoIP session. Command-line options can be entered in any order.

---

## Example of rtpcatch

The section contains an example of using **rtpcatch** and includes an explanation of its output:

### Output

```
C:\>rtpcatch faxpassthru -fax

[25]open file: 00.723, (G723) 2.213:10000 => 2.116:10002
[26]open file: 01.723, (G723) 2.116:10002 => 2.213:10000
[29] <00> 1 silence pkts from TS 1760 (seq# 3)
[42] <00> 2 silence pkts from TS 4400 (seq# 9)
[47] <00> 2 silence pkts from TS 5600 (seq# 11)
[55] <00> 2 silence pkts from TS 7760 (seq# 15)
[101]open file: 02.pcm, (G711u) 2.116:10002 => 2.213:10000
[106] <02> 2 lost pkts from seq# 39
[107]open file: 03.pcm, (G711u) 2.213:10000 => 2.116:10002
[110] <03> 1 silence pkts from TS 19440 (seq# 41)

----- Summary -----

Input file: faxpassthru.cap

<00.723>: (G723) 2.213:10000 => 2.116:10002
 total 38 pkts(70 frames), lost 0 pkts, fill 7 silence pkts

<01.723>: (G723) 2.116:10002 => 2.213:10000
 total 38 pkts(76 frames), lost 0 pkts, fill 0 silence pkts

<02.pcm>: (G711u) 2.116:10002 => 2.213:10000
 total 2181 pkts(2181 frames), lost 2 pkts, fill 0 silence pkts

<03.pcm>: (G711u) 2.213:10000 => 2.116:10002
 total 2179 pkts(2179 frames), lost 0 pkts, fill 1 silence pkts

----- FAX Summary 1 -----

[25]<2.213=>2.116> Codec G723
[26]<2.116=>2.213> Codec G723
[101]<2.116=>2.213> Codec G711u/D
[102]<2.116=>2.213> NSE PT 100, EVT 192: Up-Speed, CED tone Detected
[103]<2.116=>2.213> NSE PT 100, EVT 193: ECAN OFF, Phase Reversal Detected
[105]<2.213=>2.116> NSE PT 100, EVT 192: Up-Speed, CED tone Detected
[107]<2.213=>2.116> Codec G711u/D

----- FAX Summary 2 -----

PATH: 2.213:10000 => 2.116:10002
[25]Codec G723
[105]NSE PT 100, EVT 192: Up-Speed, CED tone Detected
[107]Codec G711u/D

PATH: 2.116:10002 => 2.213:10000
[26]Codec G723
[101]Codec G711u/D
[102]NSE PT 100, EVT 192: Up-Speed, CED tone Detected
[103]NSE PT 100, EVT 193: ECAN OFF, Phase Reversal Detected
```

## Explanation

The output is printed on screen and saved in the file file.sum.

The following lines are described:

- [ 25]open file: 00.723, (G723) 2.213:10000 => 2.116:10002

This indicates that **rtptcatch** reached NAI Sniffer packet number 25 and opened a new file named 00.723 to store an audio stream consisting of G.723-compressed data. The audio path originates from the IP address ending with 2.213 and port 10000 (written as <2.213:10000>) and terminates at the IP address ending with 2.116 and port 10002.

- [ 29] <00> 1 silence pkts from TS 1760 (seq# 3)

This indicates that **rtptcatch** detected one silence RTP packet in the audio path <00> and the silence packet began at timestamp 1760. This occurred at packet number 29 with the RTP sequence number 3.

- [ 106] <02> 2 lost pkts from seq# 39

This indicates that **rtptcatch** detected two lost RTP packets in the audio path <02>. The missing packets began with sequence number 39. This occurred at packet number 106.

- ----- Summary -----

Input file: faxpassthru.cap

<00.723>: (G723) 2.213:10000 => 2.116:10002

total 38 pkts(70 frames), lost 0 pkts, fill 7 silence pkts

This indicates that the input filename is faxpassthru.cap. The output file 00.723 contains the G.723-compressed stream from <2.123:10000> to <2.116:10002>; 38 packets (70 frames) were processed by **rtptcatch**. No lost packets were detected and seven silence packets were found.

- ----- FAX Summary 1 -----

[ 25]<2.213=>2.116> Codec G723

[ 26]<2.116=>2.213> Codec G723

[ 101]<2.116=>2.213> Codec G711u/D

[ 102]<2.116=>2.213> NSE PT 100, EVT 192: Up-Speed, CED tone Detected

[ 103]<2.116=>2.213> NSE PT 100, EVT 193: ECAN OFF, Phase Reversal Detected

[ 105]<2.213=>2.116> NSE PT 100, EVT 192: Up-Speed, CED tone Detected

[ 107]<2.213=>2.116> Codec G711u/D

This indicates that the audio streams originating at <2.213> and <2.216> are G.723-compressed. The audio stream from <2.116> was then up-spiced to G.711 $\mu$ -law at packet number 101. The NSE signaling packets were sent at packet number 102, 103 and 105. Finally, the audio stream from <2.113> was up-spiced to G.711 $\mu$ -law.

- ----- FAX Summary 2 -----

PATH: 2.213:10000 => 2.116:10002

[ 25]Codec G723

[ 105]NSE PT 100, EVT 192: Up-Speed, CED tone Detected

[ 107]Codec G711u/D

PATH: 2.116:10002 => 2.213:10000

[ 26]Codec G723

[ 101]Codec G711u/D

[ 102]NSE PT 100, EVT 192: Up-Speed, CED tone Detected

[ 103]NSE PT 100, EVT 193: ECAN OFF, Phase Reversal Detected

This summarizes the fax events for each path.

The audio stream events reported by **rtptcatch** include:

- beginning of new audio codec
- silence packets
- lost packets
- erased packets (as in G.729)

The NSE events reported by **rtppatch** include:

- event 32, Fax Mode, CED tone Detected (RFC2833)
- event 34, Modem Mode, ANSam tone Detected (RFC2833)
- event 192, Up-Speed, CED tone Detected
- event 193, ECAN OFF, Phase Reversal Detected
- event 194, ECAN ON, Silence Detected
- event 200, T38 Fax Mode, V.21 Detected
- event 201, T38 Fax Mode ACK
- event 202, T38 Fax Mode NACK
- event 203, Modem Relay Mode, CM Tone Detected
- event Cisco Fax Relay (with RTP payload type 96)
- event Cisco Fax Relay ACK (with RTP payload type 97)

## Analyzing rtppatch Output for Fax Sessions

The following examples show the proper fax events when gateways are configured to operate in the following modes:

- Cisco ATA *fax mode*
- Cisco ATA *fax pass-through mode*
- T.38 fax relay mode
- Cisco fax relay mode

### Example 7-1 Fax Mode

```
----- FAX Summary 1 -----
[25]<2.131=>3.200> Codec G711u
[26]<3.200=>2.131> Codec G711u
```

#### Analysis

Both sides use G.711 for the entire fax session.

### Example 7-2 Fax Pass-through Mode

```
----- FAX Summary 1 -----
[25]<2.213=>2.116> Codec G723
[26]<2.116=>2.213> Codec G723
[101]<2.116=>2.213> Codec G711u/D
[102]<2.116=>2.213> NSE PT 100, EVT 192: Up-Speed, CED tone Detected
[103]<2.116=>2.213> NSE PT 100, EVT 193: ECAN OFF, Phase Reversal Detected
[105]<2.213=>2.116> NSE PT 100, EVT 192: Up-Speed, CED tone Detected
[107]<2.213=>2.116> Codec G711u/D
```



**Analysis**

- Both sides initially use G.723.
- <2.116> switches to G.711 $\mu$ -law using a dynamic payload type.
- NSE signaling packets are sent from <2.116>.
- An optional NE signaling packet is sent from <2.213>.
- <2.113> switches to G.711 $\mu$ -law using a dynamic payload type.

**Note**

EVT 193 may not appear for some fax transmission.

**Example 7-3 Fax Pass-through Mode**

```
----- FAX Summary 1 -----
[37]<3.200=>2.53> Codec G723
[41]<2.53=>3.200> Codec G723
[136]<3.200=>2.53> Codec G711u/D
[137]<3.200=>2.53> NSE PT 100, EVT 192: Up-Speed, CED tone Detected
[140]<2.53=>3.200> Codec G711u/D
```

**Analysis**

- Both sides initially use G.723.
- <3.200> switches to G.711 $\mu$ -law using a dynamic payload type.
- NSE signaling packets are sent from <3.200>.
- <2.53> switches to G.711 $\mu$ -law using a dynamic payload type.

**Example 7-4 T38 Fax Relay Mode**

```
----- FAX Summary 1 -----
[15]<2.53=>3.99> Codec G711u
[486]<3.99=>2.53> Codec G711u
[1277]<3.99=>2.53> Codec T38
[1278]<2.53=>3.99> Codec T38
```

**Analysis**

- Both sides initially use G.711 $\mu$ -law.
- Both sides switch to T.38

**Example 7-5 Cisco Fax Relay**

```
----- FAX Summary 1 -----
[8]<2.53=>3.99> Codec G711u
[248]<3.99=>2.53> Codec G711u
[798]<2.53=>3.99> NSE PT 96, Cisco Fax Relay
[799]<3.99=>2.53> NSE PT 97, EVT 192: Up-Speed, CED tone Detected
[800]<2.53=>3.99> NSE PT 97, Cisco Fax Relay ACK
[801]<2.53=>3.99> Codec C_FxRly
[803]<3.99=>2.53> NSE PT 96, EVT 192: Up-Speed, CED tone Detected
[804]<2.53=>3.99> NSE PT 97, Cisco Fax Relay ACK
[805]<3.99=>2.53> Codec C_FxRly
```

**Analysis**

- Both sides initially use G.711 $\mu$ -law.
- NSE signaling packets are sent between <2.53> and <3.99>.
- Both sides switch to Cisco fax relay.

**Using rtpcatch to Analyze Common Causes of Failure**

The following examples show the **rtpcatch** output of failed fax sessions. <3.200> is ATA; <2.53> is a Cisco gateway.

**Example 7-6 Cisco ATA Configuration Failure**

```
----- FAX Summary 1 -----
[37]<2.53=>3.200> Codec G723
[39]<3.200=>2.53> Codec G723
```

**Analysis**

- <2.53> is the originating gateway and <3.200> is the terminating Cisco ATA.
- The Cisco ATA and the <2.53> gateway use G.723 codec.

**Possible Causes for Failure**

- The Cisco ATA is not configured with *fax mode* or *fax pass-through mode*.
- If the Cisco ATA is the gateway for a fax sender, the remote gateway is not configured with *fax pass-through mode*.

**Example 7-7 Fax Mode Failure**

```
----- FAX Summary 1 -----
[37]<2.53=>3.200> Codec G711
[39]<3.200=>2.53> Codec G711
[1820]<2.53=>3.200> NSE PT 96, Cisco Fax Relay
[1966]<2.53=>3.200> NSE PT 96, Cisco Fax Relay
```

**Analysis**

- <2.53> is the originating gateway and <3.200> is the terminating Cisco ATA.
- The Cisco ATA and the <2.53> gateway begin with G.711 codec.
- The <2.53> gateway sends Cisco fax relay event packets.

**Possible Cause for Failure**

- Cisco fax relay option is not disabled on the gateway.

**Example 7-8 Fax Pass-through Mode Failure**

```
----- FAX Summary 1 -----
[2]<2.53=>3.200> Codec G723
[4]<3.200=>2.53> Codec G723
[106]<3.200=>2.53> Codec G711u/D
[107]<3.200=>2.53> NSE PT 100, EVT 192: Up-Speed, CED tone Detected
```

```
[1436]<3.200=>2.53> NSE PT 100, EVT 192: Up-Speed, CED tone Detected
```

### Analysis

- <2.53> is the originating gateway, and <3.200> is the terminating Cisco ATA.
- The Cisco ATA upspeeds to G.711 $\mu$ -law and sends G.711 upspeed NSE signaling packets.
- The <2.53> gateway does not respond to the NSE signaling packets.

### Possible Causes for Failure

- Fax/modem pass-through option is not enabled on the gateway.
- Fax/modem pass-through NSE payload type are configured differently on the Cisco ATA and the gateway.

### Example 7-9 Fax Pass-through Mode Failure

```
----- FAX Summary 1 -----
[37]<2.53=>3.200> Codec G723
[39]<3.200=>2.53> Codec G723
[143]<3.200=>2.53> Codec G711u/D
[144]<3.200=>2.53> NSE PT 100, EVT 192: Up-Speed, CED tone Detected
[1602]<3.200=>2.53> NSE PT 100, EVT 192: Up-Speed, CED tone Detected
[1604]<2.53=>3.200> Codec G711u/D
[1820]<2.53=>3.200> NSE PT 96, Cisco Fax Relay
[1966]<2.53=>3.200> NSE PT 96, Cisco Fax Relay
```

### Analysis

- <2.53> is the originating gateway, and <3.200> is the terminating Cisco ATA.
- The Cisco ATA upspeeds to G.711 $\mu$ -law and sends G.711 upspeed NSE signaling packets.
- The <2.53> gateway upspeeds to G.711 $\mu$ -law and then sends Cisco fax relay event packets.

### Possible Cause for Failure

- Cisco fax relay option is not disabled on the gateway.

### Example 7-10 Fax Pass-through Mode Failure

```
----- FAX Summary 1 -----
[33]<3.200=>2.53> Codec G729
[39]<2.53=>3.200> Codec G729
[562]<2.53=>3.200> NTE PT 101, EVT 34: Modem Mode, ANSam tone Detected (RFC2833)
[563]<2.53=>3.200> NTE PT 101, EVT 34: Modem Mode, ANSam tone Detected (RFC2833)
[565]<2.53=>3.200> NTE PT 101, EVT 34: Modem Mode, ANSam tone Detected (RFC2833)
[566]<2.53=>3.200> Codec G711u/D
[568]<2.53=>3.200> NTE PT 101, EVT 34: Modem Mode, ANSam tone Detected (RFC2833)
[580]<3.200=>2.53> Codec G711u/D
```

### Analysis

- <3.200> is the originating Cisco ATA, and <2.53> is the terminating gateway.
- Both sides initially use G.729.

- <2.53> gateway sends NTE signaling packets, then upspeeds to G.711 $\mu$ -law.
- <3.200>The Cisco ATA switches to G.711 $\mu$ -law also, but never sends NTE signaling packets.
- Fax transmission fails because <2.53> gateway does not receive any NTE packets, and it drops the fax call.

**Possible Cause for Failure**

- The Cisco ATA does not support the NTE signaling method and requires that the gateways use the NSE signaling method.

**rtpcatch Limitations**

- **rtpcatch** performs optimally when analyzing capture files containing only one VoIP session.
- **rtpcatch** detects only G.711A, G.711 $\mu$ -law, G.723, G.729, T.38, Cisco fax relay, modem pass-through with or without redundancy packets, RTCP packets and NSE packets.
- **rtpcatch** can handle a maximum of 20 prserv ports using the -port option.
- **rtpcatch** may not detect T.38 packets correctly.



## Upgrading the Cisco ATA Signaling Image

This section describes two methods for upgrading the Cisco ATA software for the H.323 protocol:

- Upgrading the Signaling Image from a TFTP Server, page 8-1—This is the Cisco-recommended method for the H.323 protocol. This method is the most efficient method and requires only a one-time configuration change.
- Upgrading the Signaling Image Manually, page 8-2—This method can be used if you must manually upgrade the image of one Cisco ATA. However, this method is not the recommended upgrade method because it is not as simple as the TFTP method.

This section also describes procedures for verifying a successful image upgrade:

- Confirming a Successful Signaling Image Upgrade, page 8-5—Procedures for using your Web browser or the voice configuration menu are included.



### Caution

Do not unplug the Cisco ATA while the function button is blinking. Doing so can cause permanent damage to the device. The function button blinks during an upgrade.



### Note

The term *Cisco ATA* is used throughout this manual to refer to both the Cisco ATA 186 and the Cisco ATA 188, unless differences between the Cisco ATA 186 and Cisco ATA 188 are explicitly stated.

## Upgrading the Signaling Image from a TFTP Server

You can configure the Cisco ATA to automatically download the latest signaling image from the TFTP server. You do this configuring the parameter *upgradecode* in your Cisco ATA configuration file. (You also would use this procedure if you wanted to perform a cross-protocol signaling image upgrade.) For more information about setting up the configuration file, see the “Creating Unique and Common Cisco ATA Configuration Files” section on page 3-9.

### Syntax of upgradecode Parameter

```
upgradecode:3,0x301,0x0400,0x0200,tftp_server_ip,69,image_id,image_file_name
```

### Definitions

- The hexadecimal values that precede the *tftp\_server\_ip* variable must always be the values shown in the syntax.

- `tftp_server_ip` is the TFTP server that contains the latest signaling image file.
- `image_id` is a unique 32-bit integer that differs with each upgrade. You can determine this 32-bit integer value by using the build date on the image file name and prepending it with "0x". For example, if the `image_file_name` is `ata186-v2-14-020514a.kxz`, then the build date is `020508a`, and the `image_id` is `0x020508a`.
- `image_file_name` is the firmware upgrade-image file name. The `image_file_name` format is:
 

```
ata186-v{M}-{N}-{yyymmdd}{a-f}{ext}
```

  - - `M` is the major version number
  - - `N` is the minor version number (always two digits)
  - - `yyymmdd` is a two-digit year, two-digit month, and two-digit day
  - - `a-f` is the build letter (- `yyymmdd` and `a-f` together form the build date of the image)
  - - `ext` must be ".kxz" for upgrading from version 2.11 and below, and can be ".zup" for upgrading from version 2.12 and up for the Cisco ATA186, but it *must* be ".zup" for upgrading the Cisco ATA188.

### Process

Whenever the Cisco ATA administrator stores a new signaling image (denoted by a change to the `image_id`), the Cisco ATA upgrades its firmware with the new `image_file`. To contact the TFTP server, the Cisco ATA uses the TFTP server IP address that is contained within the value of the `upgradecode` parameter.

### Example

The `upgradecode` parameter value could be:

```
upgradecode:3,0x301,0x0400,0x0200,192.168.2.170,69,0x020723a,ata186-v2-15-020723a.zup
```

This instructs the Cisco ATA to upgrade its firmware to `ata186-v2-15-020723a.zup` by downloading the `ata186-v2-15-020723a.zup` file from the TFTP server IP address of `192.168.2.170`. This download occurs after the Cisco ATA downloads its configuration file that contains the directive from the `upgradecode` parameter. Also, the upgrade occurs only if the internally cached `image_id` in Cisco ATA is different from the value `0x020723a`.

## Upgrading the Signaling Image Manually

This section describes how to manually upgrade the Cisco ATA with the most recent signaling image. The executable file that you need is called `ata186us.exe`, and is bundled in the Cisco ATA release-software zip file.

This section contains the following topics:

- Preliminary Steps, page 8-3
- Running the Executable File, page 8-3

## Preliminary Steps

Before you run the executable file, be sure to complete the following procedure:

### Procedure

- 
- Step 1** If you are a registered CCO user, go to the following URL:  
<http://www.cisco.com/cgi-bin/tablebuild.pl/ata186>
- Step 2** Locate the zip file that contains the software for the applicable release and signaling image you are using. The contents of each file are described next to the file name. Extract the signaling image file (this file has an extension of .zup—For example, ata186-v2-15-020723a.zup) and store it on the PC that has connectivity with the Cisco ATA.
- Step 3** Set the Cisco ATA parameter UseTftp to 0.
-  **Note** Remember to set this parameter back to 1 before you use the TFTP upgrade method at a later time.
- 
- Step 4** Follow the instructions in the “Running the Executable File” section on page 8-3.
- 

## Running the Executable File

This section includes the procedure for running the executable file and using the voice configuration menu to complete the upgrade process. First check to make sure the upgrade requirements are met and determine the syntax to use when running the program.

This section contains the following topics:

- “Upgrade Requirements” section on page 8-3
- “Syntax” section on page 8-4
- “Upgrade Procedure and Verification” section on page 8-4

## Upgrade Requirements

The following list contains the requirements for using the ata186us.exe file and the voice configuration menu to upgrade the Cisco ATA to the latest signaling image:

- A network connection between the PC from which you will invoke the executable file and the Cisco ATA
- A PC running Microsoft Windows 9X/ME/NT/2000

## Syntax

```
ata186us [-any] {-h[host_ip]} {-p[port]} {-quiet} [-d1 -d2 -d3] <image file>
```

### Definitions

- `-any`—Allow upgrade regardless of software and build versions (recommended).
- `-h[host_ip]`—Set the upgrade server to a specific IP address in cases where there may be more than one IP address for the host. The default behavior is that the program will use the first IP address it obtains when it runs the `gethostbyname` command.
- `-p[port]`—Set the server port to a specific port number (the default port number is 8000; use a different port number only if you are setting up an upgrade server other than the default).
- `-quiet`—Quiet mode; send all output to log file named as `[port].log` (useful when running the upgrade server as a daemon).
- `-d1`, `-d2`, `-d3`—Choose a verbosity level for debugging, with `-d3` being the most verbose.
- `image file`—This is the name of the signaling image file to which the Cisco ATA will upgrade.

### Example

To upgrade the Cisco ATA to the signaling image `ata186-v2-15-020723a.zup`, you can use the following syntax:

```
ata186us -any -d1 ata186-v2-15-020723a.zup
```

## Upgrade Procedure and Verification

To perform the upgrade, follow these steps:

### Procedure to Upgrade Signaling Image

- 
- Step 1** Run the executable file (see the “Syntax” section on page 8-4) from the Microsoft Windows DOS or command prompt. You will receive instructions on how to upgrade.
- Step 2** On the Cisco ATA, press the function button to invoke the voice configuration menu.
- Step 3** Using the telephone keypad, enter the following:

```
100# ip_address_of_PC * port #
```

This is the IP address of the PC and the port number at the DOS prompt where you invoked the `ata186us.exe` file.

For example, if the IP address is 192.168.1.10, and the port number is 8000 (the default), then enter:

```
100#192*168*1*10*8000#
```

When the upgrade is complete, the "Upgrade Successful" prompt will sound.

---



### Note

When upgrading many Cisco ATAs manually, you can save the software-upgrade dial-pad sequence in your telephone's speed-dial, and use this sequence repeatedly.

---



# Confirming a Successful Signaling Image Upgrade

You can verify that you have successfully upgraded the Cisco ATA signaling image by using one of the following methods:

- Using a Web Browser, page 8-5
- Using the Voice Configuration Menu, page 8-6

## Using a Web Browser

To use your web browser to verify a successful image upgrade, perform the following steps:

### Procedure

---

- Step 1** Open your web browser.
- Step 2** Enter the IP address of your Cisco ATA Web configuration page:  
`http://<IP address>/dev`
- Step 3** Refresh the page to clear the cache.

The image version number and its build date should appear at the bottom-left corner of the Cisco ATA Web configuration page.

---

## Using the Voice Configuration Menu

To use the voice configuration menu to verify a successful image upgrade, perform the following steps:

### Procedure

- 
- Step 1** Pick up the telephone handset attached to the **Phone1** port of the Cisco ATA.
  - Step 2** Press the function button on the Cisco ATA.
  - Step 3** Press **123#** on the telephone keypad to play out the image version number.  
Press **123123#** on the telephone keypad to play out the image build date.
-



# Troubleshooting

---

This section describes troubleshooting procedures for the Cisco ATA:

- General Troubleshooting Tips, page 9-1
- Symptoms and Actions, page 9-2
- Installation and Upgrade Issues, page 9-3
- Debugging, page 9-4
- Using System Diagnostics, page 9-5
- Local Tone Playout Reporting, page 9-9
- Obtaining Network Status Prior to Getting IP Connectivity, page 9-10
- Obtaining Network Status After Getting IP Connectivity, page 9-11
- DHCP Status HTML Page, page 9-12
- Real-Time Transport Protocol (RTP) Statistics Reporting, page 9-12
- Frequently Asked Questions, page 9-13
- Contacting TAC, page 9-15



**Note**

---

The term *Cisco ATA* is used throughout this manual to refer to both the Cisco ATA 186 and the Cisco ATA 188, unless differences between the Cisco ATA 186 and Cisco ATA 188 are explicitly stated.

---

## General Troubleshooting Tips

The suggestions in this section are general troubleshooting tips.

- Make sure that the DHCP server is operating correctly. Note that the function button blinks slowly when the Cisco ATA attempts to acquire the DHCP configuration.
- If the green activity LED is not flashing after you connect the Ethernet cable, make sure that both the power cord and the Ethernet connection are secure.
- If there is no dial tone, make sure that the telephone line cord from the telephone is plugged into the appropriate port on the Cisco ATA. Make sure that your Cisco ATA is properly registered on your Call Control system. Test another phone; if this phone does not work either, there may be a problem with the current configuration or with the Cisco ATA.

- A busy tone indicates that the party you called is not available. Try your call again later. A fast-busy tone indicates that you dialed an invalid number.
- After power up, if the function button continues to blink slowly, the Cisco ATA cannot locate the DHCP server. Check the Ethernet connection and the availability of the DHCP server.
- The DHCP server should show an incoming request from the MAC address listed on the product label or given by the voice prompt.
- If you place a call to another IP telephone, detect ringing, and the called party answers but you cannot detect the speaker's voice, verify that the Cisco ATA and the other IP telephone support at least one common audio codec: G.711A-law, G.711 $\mu$ -law, G.723.1, or G.729A.

## Symptoms and Actions

**Symptom** Parameters with values set by using the web server interface or voice configuration menu revert to their original settings.

**Possible Cause** You are using TFTP for configuration (the UseTFTP parameter is set to 1). The Cisco ATA has a cached version of its configuration file stored in its flash memory; this is what displayed or played through the web server interface or voice configuration menu. If UseTFTP is set to 1, then the cached value of the Cisco ATA configuration file is synchronized with its configuration file located at the TFTP server. This synchronization update of the cached value occurs at approximate intervals determined by the CFGInterval parameter value as well as when the Cisco ATA powers up or resets.

**Recommended Action** If you are using TFTP for configuration, do not use the web server interface or voice configuration menu to modify the value of the Cisco ATA configuration file. Use the web server interface or voice configuration menu only to initially configure the Cisco ATA to contact the TFTP server for the Cisco ATA configuration file.

**Symptom** Unable to access the web configuration page.

**Possible Cause** Software versions earlier than 2.0 require the web configuration page to be enabled using option 80# on the voice configuration menu.

**Recommended Action** Upgrade the software.

**Symptom** The Cisco ATA does not seem to be configured using the TFTP server.

**Possible Cause** The TFTP server address is not properly set.

**Recommended Action** Ensure that the TftpURL is correctly set to the URL or IP address of the TFTP server that is hosting the configuration file for the Cisco ATA. If you are using DHCP to supply the TFTP server IP address, make sure that the TftpURL is set to 0. Also, unless the TftpURL is an IP address, be sure that the DNS1IP and DNS2IP values are properly set to resolve the TftpURL supplied by DHCP.

**Symptom** The Cisco ATA contacts the TFTP server more often than specified in the CfgInterval parameter.

**Possible Cause** The ToConfig parameter is not set to 0.

**Recommended Action** After the Cisco ATA has a valid configuration file, the ToConfig parameter must be set to 0. If it is not set to 0, the Cisco ATA will attempt to contact the TFTP server too frequently.

**Symptom** Cannot place call.

**Possible Cause** Equipment failure on the network.

**Recommended Action** Replace defective network equipment.

**Possible Cause** Recipient has not registered the IP phone.

**Recommended Action** Register the IP phone.

**Possible Cause** Ethernet cable is not connected.

**Recommended Action** Make sure that all cables are connected.

**Symptom** Fast busy tone.

**Possible Cause** Authentication credential is incorrect.

**Recommended Action** Verify authentication credential, and revise if necessary.

**Possible Cause** Recipient has not registered the IP phone.

**Recommended Action** Register the IP phone.

**Possible Cause** No common codec between the Cisco ATA and remote end.

**Recommended Action** Change codec to one that is common with the Cisco ATA and the remote end.

**Possible Cause** Recipient is in a call with call waiting disabled.

**Recommended Action** Attempt to place the call at a later time.

## Installation and Upgrade Issues



### Note

The following issues apply to the manual image-upgrade process only. Image upgrades must be performed separately.

**Symptom** The red LED is flashing slowly on the function button.

**Possible Cause** The Cisco ATA is trying to obtain the DHCP address or the software image is being upgraded.

**Possible Cause** The Ethernet cable is unplugged.

**Recommended Action** Plug in the Ethernet cable.

**Symptom** Voice prompt returns *Upgrade not available* message. This can only occur if you are using the executable-file upgrade method.

**Possible Cause** You are attempting to upgrade to the existing version.

**Recommended Action** You do not need to upgrade.

**Symptom** Voice prompt returns *Upgrade failed* message. This can only occur if you are using the executable-file upgrade method.

**Possible Cause** You have entered an incorrect IP address.

**Recommended Action** Enter the correct IP address.

**Possible Cause** Software image is corrupted.

**Recommended Action** Upgrade software image.

**Symptom** No dial tone.

**Possible Cause** No user ID was entered.

**Recommended Action** Enter the correct user ID.

**Symptom** Incorrect dial tone.

**Possible Cause** Check the web interface for your DialTone setting. The default is *U.S.*

**Recommended Action** Set the correct country DialTone value.

## Debugging

The MS-DOS Windows-based debugging program tool, `preserv.exe`, is included in every software upgrade package. The tool is also available from Cisco TAC. The `preserv` program is used in conjunction with the `NPrintf` configuration parameter. This file serves as an upgrade server that captures debug information sent by the Cisco ATA software to your PC's IP address and port number. This debug file (`preserv.exe`) compiles the information from the Cisco ATA into a readable log file. To capture this "NPRINTF" information, you must know the IP address of the PC using the `preserv` program, illustrated as follows:

```
IP address.port
```

where *IP address* is the IP address of your PC, and *port* is 9001. If another process on your PC already uses port 9001, you may use some other value (legal values are from 1024 to 65535). If no port value is entered, the default value is 9001.

To enter the IP address and port number, use voice menu option 81#. You must enter the IP address and port number in alphanumeric format, which requires entering the \* key after every character entered. To enter the "." character, you must enter the sequence 1 1#.

For example, for a computer with the IP address 172.28.78.90 and port number 9001 (172.28.78.90.9001), you would enter the following on your telephone handset:

**1\* 7\* 2\* 1 1\* 2\* 8\* 1 1\* 7\* 8\* 1 1\* 9\* 0\* 1 1\* 9\* 0\* 0\* 1\* \***

To operate the debug capture program *prserv.exe*, place the *prserv* program in a folder on your PC; then at the DOS prompt of the folder where you have placed it, enter:

```
C:> prserv [-t] port.log
```

where *port* is the port number you have selected, and *-t*, which is optional, means that a time stamp will be included with each message in the form *yy:mm:dd:hh* (two-digit years, two-digit months, two-digit days, two-digit hours). If you do not enter *port.log*, debug information still appears on your screen, but it is not saved to a log file.

After you finish capturing debug information, you can stop the log program by entering Ctrl-C at the DOS prompt. The log file created is named *port.log*. If you restart the process without changing the name of the log file, any new debug information is appended to the end of the original file.

Contact Cisco TAC for more information. See the “Obtaining Technical Assistance” section on page xvii for instructions.

You should also have access to a sniffer or LAN analyzer.



#### Caution

For security reasons, Cisco recommends that you do not use the web interface over the public network. Disable the web interface, using the *UIPassword* parameter, before the Cisco ATA is moved from the service provider site.

## Using System Diagnostics

The Cisco ATA uses functionality of the syslog protocol for system diagnostics. For detailed information on syslog, see *RFC-3164*.



#### Note

Because the Cisco ATA does not have an internal clock, syslog messages provide the time offset from the most recent Cisco ATA reset. The system administrator should make sure that the syslog relay or syslog server adds the local timestamps upon receiving syslog messages.

#### Message Syntax

```
<Priority>Time_Offset ATA_IP [tag] : [ch]Message
```

**Syntax Definitions**

- Priority means the facility and severity values for a specific syslog message.

Priority = (facility value) \* 8 + (severity value). Facility and severity definitions and values are supplied in RFC-3164; these values can be calculated if you know the priority value.

- Time\_offset means the time elapsed since the most recent Cisco ATA reset.

If the time offset is less than 24 hours, this value is shown as:

```
hh:mm:ss
```

If the time offset is more than 24 hours, this value is shown as:

```
dd hh:mm:ss
```

where the first *d* is the number of days elapsed since the most recent reset, and the second *d* is the letter *d*.

- ATA\_IP means the IP address of ATA.
- tag means the tag number of the syslog message. Each tag number corresponds to a particular type of message, such as an ARP message. You can turn on tracing for each type of message you want captured by configuring the Cisco ATA parameter syslogCtrl. For more information about the syslogCtrl parameter and for a complete listing of tag numbers and their corresponding message types, see the “SyslogCtrl” section on page 5-62.

Syslog information is sent to the syslog server that you configure by means of the Cisco ATA syslogIP parameter. For more information, see the “SyslogIP” section on page 5-61.

- *ch* means the active line of the Cisco ATA.  
System-level messages do not contain a *ch* field.
- Message means the syslog message. (See RFC-3164 for message formats and how to interpret the meaning of each syslog message.)

The following examples show some of the different types of messages that syslog reports.

**Example—ARP Message**

```
<62>00:00:51 192.168.3.169 [00]:ARP Update: MAC:080017014e00, IP:192.168.2.81
```

This message includes the following information:

- Priority=62, which means that the facility value is 7 (network new subsystem) and the severity value is 6 (informational messages). You can derive this information from RFC-3164.
- The time offset is 00:00:51, which means that the most recent Cisco ATA reset was 51 seconds earlier.
- The IP address of the Cisco ATA is 192.168.3.169
- The tag value is 00, which corresponds to ARP messages. This is derived from Table 5-9 on page 5-62.
- The message itself begins with *ARP Update* and can be interpreted by means of RFC-3164.

**Example—DHCP Messages**

```
<62>00:04:00 192.168.3.140 [01]:DHCP Reg: Srv:192.168.2.1 lease:120
<62>00:02:31 192.168.2.253 [01]:DHCP's sm: 255.255.254.0
<62>00:02:31 192.168.2.253 [01]:DHCP's rt: 192.168.3.254
```

These messages include the following information:



- Priority=62, which means that the facility value is 7 (network new subsystem) and the severity value is 6 (informational messages). You can derive this information from RFC-3164.
- The time offset of the first message is 00:04:00, which means that the most recent Cisco ATA reset was four minutes earlier.
- The tag value is 01, which corresponds to DHCP messages. This is derived from Table 5-9 on page 5-62.
- The messages include the DHCP server IP, lease time, subnet mask and router.

#### Example—TFTP messages

```
<94>00:04:35 192.168.3.237 [02]:Rx TFTP file:ata00012d010828(684) ok
<94>00:00:02 192.168.3.237 [02]:Rx TFTP file:ata00012d010828(-10) fail
```

These messages include the following information:

- Priority=94, which means that the facility value is 11 (FTP daemon) and the severity value is 6 (informational messages). You can derive this information from RFC-3164.
- The time offset of the first message is 00:04:35, which means that the most recent Cisco ATA reset was four minutes and 35 seconds earlier.
- The tag value is 02, which corresponds to TFTP messages. This is derived from Table 5-9 on page 5-62.
- The messages include TFTP filename, file size and transmission result.

#### Example—Cisco ATA Configuration Update Message

```
<30>00:00:01 192.168.3.237 [03]:ATA Config Update OK
```

This message includes the following information:

- Priority=30, which means that the facility value is 3 (system daemon) and the severity value is 6 (informational messages). You can derive this information from RFC-3164.
- The time offset of the message is 00:00:01, which means that the most recent Cisco ATA reset was one second earlier.
- The tag value is 03, which corresponds to Cisco ATA configuration-update messages. This is derived from Table 5-9 on page 5-62.
- This message shows indicates the status of the Cisco ATA configuration-file update.

#### Example—System Reboot Message

```
<31>00:00:00 192.168.3.220 [04]:Reboot from ata00012d010829(HWVersion1)
@192.168.3.220 (warmStart:0)
```

This message includes the following information:

- Priority=31, which means that the facility value is 3 (system daemon) and the severity value is 7 (debug-level messages). You can derive this information from RFC-3164.
- The time offset of the message is 0.
- The tag value is 04, which corresponds to system-reboot messages. This is derived from Table 5-9 on page 5-62.
- This message includes the MAC address, hardware version and IP address of the Cisco ATA, and the reason for the reboot.

**Example—Cisco ATA Event Messages**

```

<142>00:00:40 192.168.3.169 [09]:[0]OFFHOOK
<142>00:00:43 192.168.3.169 [09]:[0]ONHOOK
<142>00:01:35 192.168.3.169 [09]:[0]OFFHOOK
<142>00:01:50 192.168.3.169 [09]:[0]DTMF 2 , insum:830200
<142>00:01:50 192.168.3.169 [09]:[0]DTMF 2 , insum:854313
<142>00:01:50 192.168.3.169 [09]:[0]DTMF 1 , insum:868411
<142>00:01:50 192.168.3.169 [09]:[0]DTMF 2 , insum:861215
<142>00:01:50 192.168.3.169 [09]:[0]DTMF 0 , insum:858638
<142>00:01:51 192.168.3.169 [09]:[0]DTMF # , insum:845590
<142>00:01:51 192.168.3.169 [09]:[0]CLIP 22120

```

These messages include the following information:

- Priority=142, which means that the facility value is 17 (local use 1) and the severity value is 6 (informational messages). You can derive this information from RFC-3164.
- The time offset of the first message is 40 seconds.
- The tag value is 09, which corresponds to Cisco ATA event messages. This is derived from Table 5-9 on page 5-62.
- The *ch* (active line of the Cisco ATA) is line 0, which is the **Phone 1** port of the Cisco ATA.
- The messages include DTMF debugging (showing the key and the insum number), on/off hook, Caller ID (CLIP/CLIR) and the callee number.

**Example—Fax Event Messages**

```

<150>00:00:11 192.168.3.169 [10]:[1]MPT mode 0
<150>01:07:27 192.168.3.169 [10]:[1:0]Rx FAX
<150>01:07:27 192.168.3.169 [10]:[1]Tx MPT PT=100 NSE pkt c0000000
<150>01:07:27 192.168.3.169 [10]:[1]MPT mode 2
<150>01:07:27 192.168.3.169 [10]:[1]codec: 0 => 0
<150>01:07:27 192.168.3.169 [10]:[1]MPT mode 3
<150>01:07:27 192.168.3.169 [10]:[1]Rx MPT PT=100 NSE pkt c0000000

```

These messages include the following information:

- Priority=150, which means that the facility value is 18 (local use 2) and the severity value is 6 (informational messages). You can derive this information from RFC-3164.
- The time offset of the first message is 11 seconds.
- The tag value is 10, which corresponds to Cisco ATA event messages. This is derived from Table 5-9 on page 5-62.
- The *ch* (active line of the Cisco ATA) is line 1, which is the **Phone 2** port of the Cisco ATA..
- The messages include fax detection, transmit/receive NSE packet status and Fax codec switch information.

**Example—RTP Statistic Messages**

```

<182>00:01:58 192.168.3.169 [16]:[0]RTP Tx dur:5, pkt:275, byte:44000
<182>00:01:58 192.168.3.169 [16]:[0]RTP Rx dur:7, pkt:226, byte:35921, latePkt:0 lostPkt:0
avgJitter:0

```

These messages include the following information:

- Priority=182, which means that the facility value is 22 (local use 6) and the severity value is 6 (informational messages). You can derive this information from RFC-3164.
- The time offset of the first message is one minute and 58 seconds.

- The tag value is 16, which corresponds to RTP statistics messages. This is derived from Table 5-9 on page 5-62.
- The *ch* (active line of the Cisco ATA) is line 0, which is the **Phone 1** port of the Cisco ATA.
- The transmission statistics include the duration, packet count and byte count. The receiving statistics include the duration, packet count, byte count, last packet count, lost packet count and average jitter.

## Local Tone Playout Reporting

Local tones are tones that the Cisco ATA plays to its FXS port. Each of these tones corresponds to an identifier, and these *tone type identifiers* are placed into the *prserv* debug log. These identifiers supply information that administrators can use to help analyze call flows for debugging purposes.

Local tones are different from other tones because local tones are not carried within the inband audio. Instead, the Cisco ATA is prompted by a network event to play the tone, and the Cisco ATA generates the tone for the exclusive purpose of playing it to the attached telephone handset. For example, during a call between the Cisco ATA and a far-end phone, the far-end user might press a digit on the dial pad, thus sending an AVT Named Signaling Event to the Cisco ATA. This event prompts the Cisco ATA to generate a DTMF tone and to play the tone locally to the Cisco ATA phone.

Table 9-1 lists the tone type identifier and its description for local tone reporting.

**Table 9-1** Tone Type Identifiers

| Tone Type ID | Description                  |
|--------------|------------------------------|
| 0            | Dial tone                    |
| 1            | Busy tone                    |
| 2            | Reorder tone                 |
| 3            | Ringback tone                |
| 4            | Call-waiting tone            |
| 5            | Warning or confirmation tone |
| 6            | DTMF digit 0                 |
| 7            | DTMF digit 1                 |
| 8            | DTMF digit 2                 |
| 9            | DTMF digit 3                 |
| 10           | DTMF digit 4                 |
| 11           | DTMF digit 5                 |
| 12           | DTMF digit 6                 |
| 13           | DTMF digit 7                 |
| 14           | DTMF digit 8                 |
| 15           | DTMF digit 9                 |
| 16           | DTMF digit A                 |
| 17           | DTMF digit B                 |
| 18           | DTMF digit C                 |

**Table 9-1** Tone Type Identifiers (continued)

| Tone Type ID | Description                                          |
|--------------|------------------------------------------------------|
| 19           | DTMF digit D                                         |
| 20           | DTMF digit *                                         |
| 21           | DTMF digit #                                         |
| 22           | CPE alert signal (for off-hook Caller ID generation) |
| 23           | Outside dial tone                                    |
| 24           | Prompt tone                                          |
| 25           | Beep tone                                            |

## Obtaining Network Status Prior to Getting IP Connectivity

Using voice configuration menu code **3123#**, you can obtain basic network status to use for diagnostic purposes. After you enter this code, the Cisco ATA announces a message in the following format:

```
e123 . D . 0xX
```

where:

- D is the VLAN ID (this is a non-zero value if the Cisco ATA has entered a VLAN)
- 0xX is a bitmap value in hexadecimal format. The definition of each bit is shown in Table 9-2.

**Table 9-2** Voice Configuration Menu Network Status Bitmap

| Bit Number | Description                                    |
|------------|------------------------------------------------|
| 0          | Cisco ATA sent CDP request                     |
| 1          | VLAN ID acquired via CDP                       |
| 2          | Cisco ATA sent DHCP request                    |
| 3          | DHCP server offered IP address                 |
| 4          | Cisco ATA obtained IP address from DHCP server |
| 5          | Cisco ATA web server is ready                  |

### Example

If the hexadecimal value provided by the voice configuration menu is **0x1d**, the network status of the Cisco ATA is shown in Table 9-3.

**Table 9-3** Voice Configuration Menu Example Network Status

| Bit Number | Description                    | Boolean Value |
|------------|--------------------------------|---------------|
| 0          | Cisco ATA sent CDP request     | True          |
| 1          | VLAN ID acquired via CDP       | False         |
| 2          | Cisco ATA sent DHCP request    | True          |
| 3          | DHCP server offered IP address | True          |

**Table 9-3 Voice Configuration Menu Example Network Status (continued)**

| Bit Number | Description                                    | Boolean Value |
|------------|------------------------------------------------|---------------|
| 4          | Cisco ATA obtained IP address from DHCP server | True          |
| 5          | Cisco ATA web server is ready                  | False         |

## Obtaining Network Status After Getting IP Connectivity

Use the Cisco ATA Stats Web page (<http://<Cisco ATA IP address>/stats>) to display the following information:

- VLAN ID: D0
- tftpFile: S
- NTP: D1,D2,D3
- tftp: 0xX

where:

- D0 is the VLAN ID. It should be non-zero if the Cisco ATA has entered a VLAN.
- S is the tftp filename, which can be either `ata<macaddress>` or the filename supplied by the DHCP server.
- D1 is the local time on the Cisco ATA.
- D2 is the last NTP contact time.
- D3 is the last successful NTP contact time.

D1, D2, D3 values are shown in number of seconds since 00:00:00 UTC, 1970-01-01. If no NTP response has been received from the NTP server, the values of D1, D2, and D3 are 0.

- 0xX is a bitmap value in hexadecimal format. The definition of each bit is shown in Table 9-4.

**Table 9-4 Web Configuration Menu Network Status Bitmap**

| Bit Number | Description                                                                                        |
|------------|----------------------------------------------------------------------------------------------------|
| 0          | Cisco ATA sent request for configuration file, <code>ata&lt;macaddress&gt;</code> , to TFTP server |
| 1          | Cisco ATA sent request for configuration file, <code>atadefault.cfg</code> , to TFTP server        |
| 4          | Cisco ATA sent request for image file to TFTP server                                               |
| 5          | Cisco ATA failed to upgrade to the downloaded image file                                           |
| 8          | Configuration file is not found                                                                    |
| 9          | Bad configuration file                                                                             |
| 10         | Checksum error for configuration file                                                              |
| 11         | Decode error for configuration file (encryption related)                                           |
| 12         | Configuration file is processed successfully                                                       |

### Example

If the hexadecimal value provided by the web configuration menu is 0x1011, the network status of the Cisco ATA is shown in Table 9-5.

**Table 9-5 Web Configuration Menu Example Network Status**

| Bit Number | Description                                                                    | Boolean Value |
|------------|--------------------------------------------------------------------------------|---------------|
| 0          | Cisco ATA sent request for configuration file, ata<macaddress>, to TFTP server | True          |
| 1          | Cisco ATA sent request for configuration file, atadefault.cfg, to TFTP server  | False         |
| 4          | Cisco ATA sent request for image file to TFTP server                           | True          |
| 5          | Cisco ATA failed to upgrade to the downloaded image file                       | False         |
| 8          | Configuration file is not found                                                | False         |
| 9          | Bad configuration file                                                         | False         |
| 10         | Checksum error for configuration file                                          | False         |
| 11         | Decode error for configuration file (encryption related)                       | False         |
| 12         | Configuration file is processed successfully                                   | True          |

## DHCP Status HTML Page

You can use the following command to check the status DHCP-related information:

```
http://ipaddress/stats/
```

where *ipaddress* is the IP address of the Cisco ATA.

The information you receive includes the following:

- Elapsed time since most recent renewal of Cisco ATA IP address.
- Elapsed time since most recent successful Cisco ATA registration.
- IP address of the proxy to which the Cisco ATA is registered.

## Real-Time Transport Protocol (RTP) Statistics Reporting

To monitor the quality of service for the media stream, you can access RTP packet statistics of the two voice ports and their channels by opening the following page on the Cisco ATA Web server:

```
<Cisco ATA IP address>/rtps
```

The following RTP packet statistics are reported:

- rxDuration—the number of seconds since the beginning of reception
- rxPktCnt—the total number of RTP packets received
- rxOctet—the total number of RTP payload octets received (not including RTP header)
- latePktCnt—the total number of late RTP packets received
- totalLostPktCnt—the total number of lost RTP packets received (not including late RTP packets)
- avgJitter—an estimate of statistical variance of the RTP packet inter-arrival time, measured in timestamp unit. (Calculation is based on the formula in RFC1889.)
- txDuration—the number of seconds since the beginning of transmission

- txPktCnt—the total number of RTP packets transmitted
- txOctet—the total number of RTP payload octets transmitted

Using the refresh feature on the RTP Statistics page, you can obtain updated, real-time RTP statistics during a call.

#### Resetting Cisco ATA counters

To reset the Cisco ATA counters, do the following:

- Click the [Refresh] link to refresh the current counter values.
- Click the [Line 0] link to reset line 0 counter values.
- Click the [Line 1] link to reset line 1 counter values.



**Note**

Inactive lines will be indicated as such.

## Frequently Asked Questions

- Q.** Does the Cisco ATA support power denial when disconnecting a call?
- A.** No. However, the Cisco ATA can be configured to reverse the voltage polarity when a call is connected or disconnected. See the “Polarity” section on page 5-39.
- Q.** How can I recover the box if I forgot the password?
- A.** There are two important passwords. One is the UIPassword, which protects access to the Cisco ATA Web Server interface; the other is the EncryptKey, which protects access to the TFTP configuration file. If you forget the value for the UIPassword but still have access to TFTP-stored configuration file, you can modify the UIPassword via TFTP. However, if you are not configuring the Cisco ATA via TFTP, or if you forget both passwords, the only way you can recover the box is to have physical access to the box and do a factory reset on the box via the box voice configuration menu interface (Access Code: FACTRESET#). See the “Resetting the Cisco ATA to Factory Default Values” section on page 3-23.
- Q.** What is the maximum distance from which I can drive an analog device with a Cisco ATA?
- A.** Table 9-6 provides maximum distances for this question.

**Table 9-6 Ring Loads and Distances**

| Ring Load (per RJ-11 FXS Port) | Maximum Distance  |
|--------------------------------|-------------------|
| 5 REN                          | 200 feet (61 m)   |
| 4 REN                          | 1000 feet (305 m) |
| 3 REN                          | 1700 feet (518 m) |
| 2 REN                          | 2500 feet (762 m) |
| 1 REN                          | 3200 feet (975 m) |

The Cisco ATA, however, is not designed for long distance. The simple test is to determine if the phone or phones that are connected to the Cisco ATA work properly in their environment.

Pay attention to the following questions:

1. Can the Cisco ATA detect on/off hook from the analog phone?
2. Can the Cisco ATA detect the DTMF signal?
3. Can you dial the remote side?
4. Can the Cisco ATA ring the phone?
5. Is voice quality satisfactory?

If you answer no to any of the above questions, you may have a loop impedance greater than 400 ohm. In this case, perform the following procedure.

#### Procedure

- 
- Step 1** Increase the wire gauge to reduce the impedance until the Cisco ATA can detect on/off hook and DTMF signal.
- Step 2** If the Cisco ATA cannot ring the phone, find a phone that can ring at a lower ringing voltage. Also, try to use only one phone instead of multiple phones in parallel.
- 

- Q.** Does the Cisco ATA support an overhead paging system, and, if so, does the Cisco ATA support power denial?
- A.** The Cisco ATA supports an overhead paging system *only* if that system does not require power denial (battery removal) when a call is disconnected. However, the Cisco ATA can be configured to reverse the voltage polarity when a call is connected or disconnected. For more information, see the “Polarity” section on page 5-39.
- Q.** How do you use NetMeeting to make a direct IP call with a Cisco ATA that is running H.323?
- A.** Follow the steps below:

#### Procedure

- 
- Step 1** From the NetMeeting **Tools** menu, click **Options**.
- Step 2** Click the **Advanced Calling** button.
- Step 3** Check the **Gateway Settings** box and enter the IP address of the Cisco ATA.
- Step 4** Click **OK**.
- Step 5** Proceed as usual and place your call.



---

**Note** Always use the configured User ID number when making a new call with NetMeeting.

---



# Contacting TAC

Qualified customers who need to contact the Cisco Technical Assistance Center (TAC) must provide the following information:

- Product codes.
- Software version number—To identify the software revision number, use the configuration menu number **123**.
- Hardware version number—To identify the hardware revision number, use the serial number and MAC address found on the label on the bottom of the Cisco ATA. The MAC address can also be obtained using voice menu option 24.
- Software build information—To identify the software build information, use the voice menu option **123123**.
- Cisco ATA serial number.

See the “Obtaining Technical Assistance” section on page xvii for instructions on contacting TAC.

**Note**

---

Customers who obtained their equipment through service providers, independent dealers and other third parties must contact their equipment provider for technical assistance.

---





## Using H.323 Supplementary Services

---

H.323 supplementary services are services that you can use to enhance your telephone service. These services include call forward, call return, call forwarding and conference calling. Use the following parameters to enable and subscribe to supplementary services:

- CallFeatures, page 5-27—Use this parameter to enable desired features.
- PaidFeatures, page 5-28—Use this parameter to subscribe or unsubscribe to enabled features.
- This section contains the following topics:
  - Changing Call Commands, page A-1
  - Cancelling a Supplementary Service, page A-1
  - Common Supplementary Services, page A-1

### Changing Call Commands

To change the command for a supplementary service (for example, to change \*69 to \*100), change the context identifiers in the Call Command field on the Web configuration page. For more information, see Chapter 6, “Call Commands.”



**Note**

---

You cannot change supplementary services by means of the voice configuration menu.

---

### Cancelling a Supplementary Service

You can deactivate some supplementary services by pressing \*70 before making a call. You can also configure your system to have services disabled by default and enabled on a call-by-call basis. Use the 32-bit Call Features plan to handle your services in this manner. For more information, see the “CallFeatures” section on page 5-27.

### Common Supplementary Services

The supplementary services described in this section, and their configuration and implementation, depend on the system of the country in which the service is activated. For information about your country’s implementation of services, contact your local Cisco equipment provider.

This section contains the following topics:

- Caller ID, page A-2
- Call-Waiting Caller ID, page A-2
- Making a Conference Call in the United States, page A-2
- Making a Conference Call in Sweden, page A-3
- Call Waiting in the United States, page A-3
- Call Waiting in Sweden, page A-3
- Calling Line Identification Presentation, page A-3
- About Calling Line Identification Restriction, page A-4
- Calling Line Identification Restriction in the United States, page A-4
- Calling Line Identification Restriction in Sweden, page A-4

## Caller ID

When the telephone rings, the Cisco ATA sends a Caller ID signal to the telephone between the first and second ring (with name, telephone number, time, and date information, if these are available).

## Call-Waiting Caller ID

The Cisco ATA plays a call waiting tone, then sends an off-hook Caller ID signal to the telephone immediately after the first tone burst.

The Cisco ATA sends the name, telephone number, time, and date information, if these are available.

## Making a Conference Call in the United States

### Procedure

---

- Step 1** Dial the first number.
  - Step 2** When the person you called answers, press the flash or receiver button on the telephone handset. This will put the first person you called on hold and you will receive a dial tone.
  - Step 3** Dial the second person and speak normally when that person answers.
  - Step 4** To conference with both callers at the same time, perform a hook flash.
  - Step 5** To drop the second call, perform a hook flash.
  - Step 6** (Optional) To conference in additional callers, the last person called with a Cisco ATA can call an additional person, that new person can then call someone else, and so on. This is known as *daisy-chaining*.
-

## Making a Conference Call in Sweden

### Procedure

---

- Step 1** Dial the first number.
- Step 2** When the person you called answers, press the flash or receiver button on the telephone handset. This will put the first person you called on hold and a dial tone will sound.
- Step 3** Dial the second person and speak normally when that person answers.
- Step 4** Perform a hookflash, then press **2** on your telephone keypad to return to the first person. You can continue to switch back and forth between the two callers.
- Step 5** To conference with both callers at the same time, perform a hookflash, then press **3** on the telephone keypad. Once you conference all three callers, the only way to drop a caller is for that caller to hang up.
- Step 6** (Optional) To conference in additional callers, the last person called with a Cisco ATA can call an additional person, that new person can call someone else, and so on. This is known as “daisy-chaining.”
- 

## Call Waiting in the United States

If someone calls you while you are speaking on the telephone, you can answer by performing a hook flash. You cannot conference in all three callers, but the first person you called could call someone else and daisy-chain them into the conference.

When the Cisco ATA is configured to use Call Waiting by default, press **\*70** on your telephone keypad to disable Call Waiting for the duration of the next call.

## Call Waiting in Sweden

If someone calls you while you are speaking on the telephone, you can answer by performing a hookflash then pressing **2** on your telephone keypad, or you can conference them with the person to whom you are already speaking by performing a hookflash then pressing **3**. You can also perform a hookflash then press **3** later during the call to create a conference call.

Performing a hookflash then pressing **1** hangs up the first caller and answers the second call. If there is no answer after one minute, the caller receives three beeps and a busy signal.

To enable call waiting for Sweden, press **\*43#**. When the Cisco ATA is configured to use Call Waiting by default, press **#43#** to disable Call Waiting for the duration of the next call.

## Calling Line Identification Presentation

Calling Line Identification Presentation (CLIP) shows your identity to callers with Caller ID.

Press **\*82** on your telephone keypad to activate CLIP.

## About Calling Line Identification Restriction

Calling Line Identification Restriction (CLIR) hides your identity from callers with Caller ID.

## Calling Line Identification Restriction in the United States

Press **\*67** on your telephone keypad to activate CLIR. This feature is disabled when you hang up.

## Calling Line Identification Restriction in Sweden

Press **\*31#** on your telephone keypad to activate CLIR. This feature is disabled when you hang up.



## Voice Menu Codes

This section contains a quick-reference list of the voice configuration menu options for the Cisco ATA.

This section contains the following tables of voice menu codes:

- Table B-1—Information Options
- Table B-2—Configuration Parameters
- Table B-3—Software Upgrade codes



**Note**

Follow each voice menu code with #.



**Note**

The term *Cisco ATA* refers to both the Cisco ATA 186 and the Cisco ATA 188, unless otherwise stated.

Table B-1 lists codes to return basic Cisco ATA information.

**Table B-1 Cisco ATA Voice Menu Codes—Information Options**

| Option                          | Voice Menu Code | Description                                                 |
|---------------------------------|-----------------|-------------------------------------------------------------|
| Build information               | 123123          | Build date of the Cisco ATA software                        |
| Review IP address               | 21              | Returns IP address of the Cisco ATA                         |
| Review MAC address              | 24              | Returns media access control (MAC) address of the Cisco ATA |
| Review network route IP address | 22              | Returns IP address of the network route                     |
| Review subnet mask              | 23              | Returns subnet mask of the network route                    |
| Version number                  | 123             | Returns version number of the Cisco ATA software            |

Table B-2 lists configuration codes.

**Table B-2 Cisco ATA Voice Menu Codes—Configuration Parameters**

| Option                                     | Voice Menu Code | Description                                                                                                     |
|--------------------------------------------|-----------------|-----------------------------------------------------------------------------------------------------------------|
| Alternate NTP IP address                   | 78              | IP address of the alternate NTP server                                                                          |
| Audio mode                                 | 312             | Allows finer control of the audio component to suit certain user applications                                   |
| Call features                              | 314             | Subscribed features statically enabled by the user                                                              |
| Caller ID method                           | 316             | Specifies the signal format when generating the Caller ID format to use                                         |
| TFTP Configuration Interval                | 80002           | Interval (in seconds) between configuration updates when TFTP configuration is used,                            |
| Connection mode                            | 311             | Controls the connection mode of the call signaling protocol                                                     |
| Dynamic Host Configuration Protocol (DHCP) | 20              | Controls whether the Cisco ATA can automatically obtain configuration parameters from a server over the network |
| DNS 1 IP                                   | 916             | IP address of the primary DNS server                                                                            |
| DNS 2 IP                                   | 917             | IP address of the secondary DNS server                                                                          |
| Encrypt key                                | 320             | Encrypts the configuration file on the TFTP server                                                              |
| Gatekeeper/proxy server IP address         | 5               | H.323 gatekeeper IP address                                                                                     |
| H.323 protocol                             | 38              | Selects the signaling protocol                                                                                  |
| IP address                                 | 1               | IP address of the Cisco ATA                                                                                     |
| LBR codec                                  | 300             | Low bit rate codec selection                                                                                    |
| Login ID 0                                 | 46              | Alternate user ID used for authentication                                                                       |
| Login ID 1                                 | 47              | Alternate user ID used for authentication                                                                       |
| Media port                                 | 202             | Specifies which base port the Cisco ATA uses to receive RTP media streams                                       |
| Network route address                      | 2               | Network router address                                                                                          |
| NPrintf address                            | 81              | IP address of a host to which all Cisco ATA debug messages are sent                                             |
| NTP server address                         | 141             | IP address of the NTP server                                                                                    |
| Num Tx frames                              | 35              | Number of frames transmitted per packet                                                                         |
| Paid features                              | 315             | Features subscribed to by the user                                                                              |
| Polarity                                   | 304             | Controls connect and disconnect polarity                                                                        |
| PWD 0                                      | 4               | Password associated with the primary phone line (UID0 or LoginID0)                                              |
| PWD 1                                      | 14              | Password associated with the secondary phone line (UID1 or LoginID1)                                            |



**Table B-2 Cisco ATA Voice Menu Codes—Configuration Parameters (continued)**

| <b>Option</b>                 | <b>Voice Menu Code</b> | <b>Description</b>                                                                                                                                                                                                       |
|-------------------------------|------------------------|--------------------------------------------------------------------------------------------------------------------------------------------------------------------------------------------------------------------------|
| Rx codec                      | 36                     | Selects the audio codec type to use to decode received data. The call-receiving station automatically adjusts to the call-initiating station's audio codec type if the call-receiving station supports that audio codec. |
| Set password                  | 7387277                | Configuration interface password                                                                                                                                                                                         |
| Signal timers                 | 318                    | Timeout values controlling the starting or stopping of a signaling event                                                                                                                                                 |
| H.323 max number of redirects | 205                    | Maximum number of redirections the Cisco ATA will attempt to reach a callee when making a call                                                                                                                           |
| Subnet mask                   | 10                     | Specifies the subnet mask for the Cisco ATA                                                                                                                                                                              |
| TFTP URL                      | 905                    | IP address of the TFTP server when TFTP configuration is used                                                                                                                                                            |
| Timezone                      | 302                    | Specifies offset to GMT—used to time-stamp incoming calls for caller ID                                                                                                                                                  |
| ToConfig                      | 80001                  | Identifies unconfigured or already-configured Cisco ATAs                                                                                                                                                                 |
| Trace Fflags                  | 313                    | Enables logging of debug information                                                                                                                                                                                     |
| Tx Codec                      | 37                     | Selects transmitting audio codec preference                                                                                                                                                                              |
| UDP TOS bits                  | 255                    | Determines the precedence and delay of UDP IP packets                                                                                                                                                                    |
| UID 0                         | 3                      | User ID (telephone number) for the PHONE 1 port                                                                                                                                                                          |
| UID 1                         | 13                     | User ID (telephone number) for the PHONE 2 port                                                                                                                                                                          |
| Use login ID                  | 93                     | Determines which pair (UIDx, PWDx or LoginIDx, PWDx) to use for authentication                                                                                                                                           |
| Use TFTP                      | 305                    | Enables TFTP as configuration method                                                                                                                                                                                     |

Table B-3 lists codes used in the software upgrade process. For information about these codes, see Chapter 8, “Upgrading the Cisco ATA Signaling Image.”

**Table B-3 Cisco ATA Voice Menu Codes—Software Upgrade**

| <b>Option</b>               | <b>Voice Menu Code</b> | <b>Description</b>                                                                |
|-----------------------------|------------------------|-----------------------------------------------------------------------------------|
| Upgrade software            | 100                    | Used in the software process to enter the IP address of the PC                    |
| Upgrade language to English | 101                    | When upgrading software, changes or upgrades the voice prompt language to English |



## Cisco ATA Specifications

---

This section describes Cisco ATA specifications:

- Physical Specifications, page C-1
- Electrical Specifications, page C-2
- Environmental Specifications, page C-2
- Physical Interfaces, page C-2
- Ringing Characteristics, page C-3
- Software Specifications, page C-3



**Note**

The term *Cisco ATA* refers to both the Cisco ATA 186 and the Cisco ATA 188, unless otherwise stated.

---

## Physical Specifications

**Table C-1** *Physical Specifications*

| Description | Specification                                           |
|-------------|---------------------------------------------------------|
| Dimensions  | 1.5 x 6.5 x 5.75 in. (3.8 x 16.5 x 14.6 cm) (H x W x D) |
| Weight      | 15 oz (425 g)                                           |

# Electrical Specifications

**Table C-2** *Electrical Specifications*

| Description      | Specification                                                                                                                                                                                                         |
|------------------|-----------------------------------------------------------------------------------------------------------------------------------------------------------------------------------------------------------------------|
| Power            | 0.25 to 7.5W (idle to peak)                                                                                                                                                                                           |
| DC input voltage | +5.0 VDC at 1.5A maximum                                                                                                                                                                                              |
| Power adaptor    | Universal AC/DC<br>~3.3 x 2.0 x 1.3 in. (~8.5 x 5.0 x 3.2 cm)<br>~4.8 oz (135 g) for the AC-input external power adaptor<br>~4 ft (1.2 m) DC cord<br>6 ft (1.8 m) cord<br>UL/CUL, CE approved<br>Class II transformer |

# Environmental Specifications

**Table C-3** *Environmental Specifications*

| Description           | Specification                                                |
|-----------------------|--------------------------------------------------------------|
| Operating temperature | 41 to 104° F (5 to 40° C)                                    |
| Storage temperature   | -4 to 140° F (-20 to 65° C)                                  |
| Relative humidity     | 10 to 90% noncondensing, operating, and nonoperating/storage |

# Physical Interfaces

**Table C-4** *Physical Interfaces*

| Description      | Specification                                                                                |
|------------------|----------------------------------------------------------------------------------------------|
| Ethernet         | Two RJ-45 connectors, IEEE 802.3 10BaseT standard                                            |
| Analog telephone | Two RJ-11 FXS voice ports                                                                    |
| Power            | 5 VDC power connector                                                                        |
| Indicators       | Function button with integrated status indicator<br>Activity LED indicating network activity |

# Ringing Characteristics

**Table C-5** Ringing Characteristics

| Description                                        | Specification                                                                                                                                                               |
|----------------------------------------------------|-----------------------------------------------------------------------------------------------------------------------------------------------------------------------------|
| Tip/ring interfaces for each RJ-11 FXS port (SLIC) |                                                                                                                                                                             |
| Ring voltage                                       | 40V <sub>RMS</sub> (typical, balanced ringing only)                                                                                                                         |
| Ring frequency                                     | 25 Hz                                                                                                                                                                       |
| Ring waveform                                      | Trapezoidal with 1.2 to 1.6 crest factor                                                                                                                                    |
| Ring load                                          | 1400 ohm + 40μF                                                                                                                                                             |
| Ringer equivalence number (REN)                    | Up to 5 REN per RJ-11 FXS port                                                                                                                                              |
| Loop impedance                                     | Up to 200 ohms (plus 430-ohm maximum telephone DC resistance)                                                                                                               |
| On-hook/off-hook characteristics                   |                                                                                                                                                                             |
| On-hook voltage (tip/ring)                         | -50V                                                                                                                                                                        |
| Off-hook current                                   | 27 mA (nominal)                                                                                                                                                             |
| RJ-11 FXS port terminating impedance option        | The Cisco ATA186-I1 and Cisco ATA188-I1 provide 600-ohm resistive impedance. The Cisco ATA186-I2 and Cisco ATA188-I2 provide 270 ohm + 750 ohm // 150-nF complex impedance. |

# Software Specifications

**Table C-6** Software Specifications (All Protocols)

| Description                     | Specification                                                                                                                                                                                                                                                                                                                         |
|---------------------------------|---------------------------------------------------------------------------------------------------------------------------------------------------------------------------------------------------------------------------------------------------------------------------------------------------------------------------------------|
| Call progress tones             | Configurable for two sets of frequencies and single set of on/off cadence                                                                                                                                                                                                                                                             |
| Dual-tone multifrequency (DTMF) | DTMF tone detection and generation                                                                                                                                                                                                                                                                                                    |
| Fax                             | G.711 fax pass-through and G.711 fax mode.<br>Enhanced fax pass-through is supported on the Cisco ATA. Success of fax transmissions up to 14.4 kbps depends on network conditions, and fax modem/fax machine tolerance to those conditions. The network must have reasonably low network jitter, network delay, and packet-loss rate. |

**Table C-6 Software Specifications (All Protocols) (continued)**

| Description                   | Specification                                                                                                                                                                                                                                                                                                                                                                                                                                                                                          |
|-------------------------------|--------------------------------------------------------------------------------------------------------------------------------------------------------------------------------------------------------------------------------------------------------------------------------------------------------------------------------------------------------------------------------------------------------------------------------------------------------------------------------------------------------|
| Line-echo cancellation        | <ul style="list-style-type: none"> <li>• Echo canceller for each port</li> <li>• 8 ms echo length</li> <li>• Nonlinear echo suppression (ERL &gt; 28 dB for frequency = 300 to 2400 Hz)</li> <li>• Convergence time = 250 ms</li> <li>• ERLE = 10 to 20 dB</li> <li>• Double-talk detection</li> </ul>                                                                                                                                                                                                 |
| Out-of-band DTMF              | <ul style="list-style-type: none"> <li>• H.245 out-of-band DTMF for H.323</li> <li>• RFC 2833 AVT tones for SIP, MGCP, SCCP</li> </ul>                                                                                                                                                                                                                                                                                                                                                                 |
| Configuration                 | <ul style="list-style-type: none"> <li>• DHCP (RFC 2131)</li> <li>• Web configuration via built-in Web server</li> <li>• Touch-tone telephone keypad configuration with voice prompt</li> <li>• Basic boot configuration (RFC 1350 TFTP Profiling)</li> <li>• Dial plan configuration</li> <li>• Cisco Discovery Protocol</li> </ul>                                                                                                                                                                   |
| Quality of Service            | <ul style="list-style-type: none"> <li>• Class-of-service (CoS) bit-tagging (802.1P)</li> <li>• Type-of-service (ToS) bit-tagging</li> </ul>                                                                                                                                                                                                                                                                                                                                                           |
| Security                      | <ul style="list-style-type: none"> <li>• H.235 for H.323</li> <li>• RC4 encryption for TFTP configuration files</li> </ul>                                                                                                                                                                                                                                                                                                                                                                             |
| Voice coder-decoders (codecs) | <div style="border: 1px solid black; padding: 5px; margin-bottom: 10px;">  <p><b>Note</b> In simultaneous dual-port operation, the second port is limited to G.711 when using G.729.</p> </div> <ul style="list-style-type: none"> <li>• G.723.1</li> <li>• G.729, G.729A, G.729AB</li> <li>• G.723.1</li> <li>• G.711A-law</li> <li>• G.711<math>\mu</math>-law</li> </ul> |

**Table C-6 Software Specifications (All Protocols) (continued)**

| <b>Description</b>             | <b>Specification</b>                                                                                                                                                                                                       |
|--------------------------------|----------------------------------------------------------------------------------------------------------------------------------------------------------------------------------------------------------------------------|
| Voice features                 | <ul style="list-style-type: none"><li>• Voice activity detection (VAD)</li><li>• Comfort noise generation (CNG)</li><li>• Dynamic jitter buffer (adaptive)</li></ul>                                                       |
| Voice-over-IP (VoIP) protocols | <ul style="list-style-type: none"><li>• H.323 v2</li><li>• SIP (RFC 2543 bis)</li><li>• MGCP 1.0 (RFC 2705)</li><li>• MGCP 1.0/network-based call signalling (NCS) 1.0 profile</li><li>• MGCP 0.1</li><li>• SCCP</li></ul> |







## H.323 Signaling

This section describes some basic call flows for the Cisco ATA:

- Supported H.323 Messages, page D-1
- H.323 Signaling Scenarios, page D-2



**Note**

---

The term *Cisco ATA* is used throughout this manual to refer to both the Cisco ATA 186 and the Cisco ATA 188, unless differences between the Cisco ATA 186 and Cisco ATA 188 are explicitly stated.

---

## Supported H.323 Messages

The Cisco ATA supports the following H.323 request methods:

- Request—When registering with an H.323 gatekeeper or Gateway, an individual H.323 endpoint must begin the process by sending a request message.
- Confirm—H.323 gatekeepers and Gateways authorize individual H.323 endpoints to access and send data over the H.323 network with explicit confirmation messages.
- Reject—In the event that an H.323 gatekeeper or Gateway is unable to grant access permission to an H.323 endpoint, a rejection message is sent and call setup is halted.
- Setup—Once access to the H.323 network has been granted, H.323 components contact remote H.323 components via setup messages, initiating two-way voice, video, or data communication.
- Proceeding—When a remote H.323 component acknowledges receipt of call initiation information and agrees to perform necessary subsequent setup for two-way voice, video, or data communication, it responds with a proceeding message.
- Alerting—When a remote H.323 endpoint has begun to notify the called party of an incoming call (the phone begins to ring at the far end), an alerting message is sent back to the calling party.
- Connect—When the called party answers the call (the phone goes off hook), the remote H.323 endpoint transmits a connecting message notifying the calling party that two-way communication is ready to commence.

## H.323 Signaling Scenarios

This section describes call flows for the following scenarios:

- H.323 Endpoint-to-Gatekeeper Registration, page D-2
- H.323 Endpoint-to-Endpoint Call Setup with a Common Gatekeeper, page D-5
- H.323 Call Setup from H.323 Network to Circuit Switched Network, page D-14

Each of the call flows includes a call diagram, action descriptions table, and a sample log file.

### H.323 Endpoint-to-Gatekeeper Registration

Figure D-1 illustrates the Cisco ATA registering with an H.323 gatekeeper. This scenario features registration with no authentication.

**Figure D-1 Cisco ATA-to-H.323 Gatekeeper Registration**

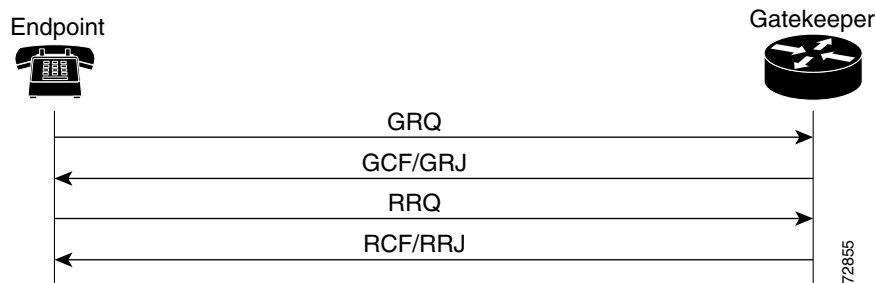

**Table D-1 Action Descriptions**

| Step | Action                                                                                        | Description                                                                                                                                   |
|------|-----------------------------------------------------------------------------------------------|-----------------------------------------------------------------------------------------------------------------------------------------------|
| 1.   | Gatekeeper Request (GRQ)—Cisco ATA to H.323 gatekeeper                                        | Cisco ATA sends a GRQ message to the H.323 gatekeeper to see if any gatekeepers are available for registration.                               |
| 2.   | Gatekeeper Confirmation (GCF) or gatekeeper Rejection (GRJ)—H.323 gatekeeper to Cisco ATA     | H.323 gatekeeper returns a GCF or GRJ message, indicating whether or not the responding gatekeeper is able to register new Cisco ATA devices. |
| 3.   | Registration Request (RRQ)—Cisco ATA to H.323 gatekeeper                                      | Cisco ATA sends a RRQ message to the H.323 gatekeeper in an attempt to register as part of that gatekeeper's zone.                            |
| 4.   | Registration Confirmation (RCF) or Registration Rejection (RRJ)—H.323 gatekeeper to Cisco ATA | H.323 gatekeeper returns a RCF or RRJ message, indicating whether or not the gatekeeper will add the Cisco ATA to its zone.                   |

Table D-2 Log Listings

|    |                                                                                                                                                                                                                                                                                                                                                                                                                                                                                                                                                                                                                                                                                                                                                                                                                                                                                                                                                                                                                                           |
|----|-------------------------------------------------------------------------------------------------------------------------------------------------------------------------------------------------------------------------------------------------------------------------------------------------------------------------------------------------------------------------------------------------------------------------------------------------------------------------------------------------------------------------------------------------------------------------------------------------------------------------------------------------------------------------------------------------------------------------------------------------------------------------------------------------------------------------------------------------------------------------------------------------------------------------------------------------------------------------------------------------------------------------------------------|
| 1. | <pre> value RasMessage ::= gatekeeperRequest : 3w2d: { 3w2d:   requestSeqNum 037472, 3w2d:   protocolIdentifier { 0 0 8 2250 0 2 }, 3w2d:   rasAddress ipAddress : 3w2d:     { 3w2d:       ip 'COA80267'H, 3w2d:       port 02712 3w2d:     }, 3w2d:   endpointType 3w2d:     { 3w2d:       gateway 3w2d:         { 3w2d:           protocol 3w2d:             { 3w2d:               voice : 3w2d:                 { 3w2d:                   supportedPrefixes 3w2d:                     { 3w2d:                       } 3w2d:                     } 3w2d:                 } 3w2d:             } 3w2d:         }, 3w2d:       mc FALSE, 3w2d:       undefinedNode FALSE 3w2d:     }, 3w2d:   gatekeeperIdentifier "c2600gk.komodo-tech.com", 3w2d:   endpointAlias 3w2d:     { 3w2d:       h323-ID : "c2600gw", 3w2d:       e164 : "14085551102", 3w2d:       e164 : "14088713483", 3w2d:       e164 : "14088713484", 3w2d:       e164 : "5551111", 3w2d:       e164 : "7771111", 3w2d:       e164 : "8881111" 3w2d:     } 3w2d: } </pre> |
| 2. | <pre> 3w2d:value RasMessage ::= gatekeeperConfirm : 3w2d: { 3w2d:   requestSeqNum 037472, 3w2d:   protocolIdentifier { 0 0 8 2250 0 2 }, 3w2d:   gatekeeperIdentifier "c2600gk.komodo-tech.com", 3w2d:   rasAddress ipAddress : 3w2d:     { 3w2d:       ip 'COA80268'H, 3w2d:       port 01719 3w2d:     } 3w2d: } </pre>                                                                                                                                                                                                                                                                                                                                                                                                                                                                                                                                                                                                                                                                                                                 |

Table D-2 Log Listings (continued)

|    |                                                                                                                                                                                                                                                                                                                                                                                                                                                                                                                                                                                                                                                                                                                                                                                                                                                                                                                                                                                                                                                                                                                                                                                                                                                                                                                                               |
|----|-----------------------------------------------------------------------------------------------------------------------------------------------------------------------------------------------------------------------------------------------------------------------------------------------------------------------------------------------------------------------------------------------------------------------------------------------------------------------------------------------------------------------------------------------------------------------------------------------------------------------------------------------------------------------------------------------------------------------------------------------------------------------------------------------------------------------------------------------------------------------------------------------------------------------------------------------------------------------------------------------------------------------------------------------------------------------------------------------------------------------------------------------------------------------------------------------------------------------------------------------------------------------------------------------------------------------------------------------|
| 3. | <pre> value RasMessage ::= registrationRequest : 3w2d: { 3w2d:   requestSeqNum 02, 3w2d:   protocolIdentifier { 0 0 8 2250 0 2 }, 3w2d:   discoveryComplete TRUE, 3w2d:   callSignalAddress 3w2d:   { 3w2d:     ipAddress : 3w2d:     { 3w2d:       ip 'COA80260'H, 3w2d:       port 01720 3w2d:     } 3w2d:   }, 3w2d:   rasAddress 3w2d:   { 3w2d:     ipAddress : 3w2d:     { 3w2d:       ip 'COA80260'H, 3w2d:       port 01719 3w2d:     } 3w2d:   }, 3w2d:   terminalType 3w2d:   { 3w2d:     vendor 3w2d:     { 3w2d:       vendor 3w2d:       { 3w2d:         t35CountryCode 05, 3w2d:         t35Extension 00, 3w2d:         manufacturerCode 020001 3w2d:       }, 3w2d:       productId '4B6F6D6F646F204520466F6E65'H, 3w2d:       versionId '56657273696F6E20312E3130'H 3w2d:     }, 3w2d:     terminal 3w2d:     { 3w2d:     }, 3w2d:     mc FALSE, 3w2d:     undefinedNode FALSE 3w2d:   }, 3w2d:   terminalAlias 3w2d:   { 3w2d:     h323-ID : "196" 3w2d:   }, 3w2d:   endpointVendor 3w2d:   { 3w2d:     vendor 3w2d:     { 3w2d:       t35CountryCode 05, 3w2d:       t35Extension 00, 3w2d:       manufacturerCode 020001 3w2d:     }, 3w2d:     productId '4B6F6D6F646F204520466F6E65'H, 3w2d:     versionId '56657273696F6E20312E3130'H 3w2d:   }, 3w2d:   keepAlive FALSE, 3w2d:   willSupplyUUIEs FALSE 3w2d: } </pre> |
| 4. | <pre> 3w2d:value RasMessage ::= registrationConfirm : 3w2d: { 3w2d:   requestSeqNum 02, 3w2d:   protocolIdentifier { 0 0 8 2250 0 2 }, 3w2d:   callSignalAddress 3w2d:   { 3w2d:   }, 3w2d:   terminalAlias 3w2d:   { 3w2d:     h323-ID : "196" 3w2d:   }, 3w2d:   gatekeeperIdentifier "c2600gk.komodo-tech.com", 3w2d:   endpointIdentifier "80F5235000009E12", 3w2d:   timeToLive 03548, 3w2d:   willRespondToIRR FALSE 3w2d: } </pre>                                                                                                                                                                                                                                                                                                                                                                                                                                                                                                                                                                                                                                                                                                                                                                                                                                                                                                     |

## H.323 Endpoint-to-Endpoint Call Setup with a Common Gatekeeper

Figure D-2 illustrates a Cisco ATA initiating a connection to another Cisco ATA that is registered with the same H.323 gatekeeper. This scenario features registration with no authentication.



**Note**

This scenario assumes that the H.323 configuration employs Slow Start Signaling with tunneling capability.

**Figure D-2 H.323 Endpoint-to-Endpoint Call Setup with a Common Gatekeeper**

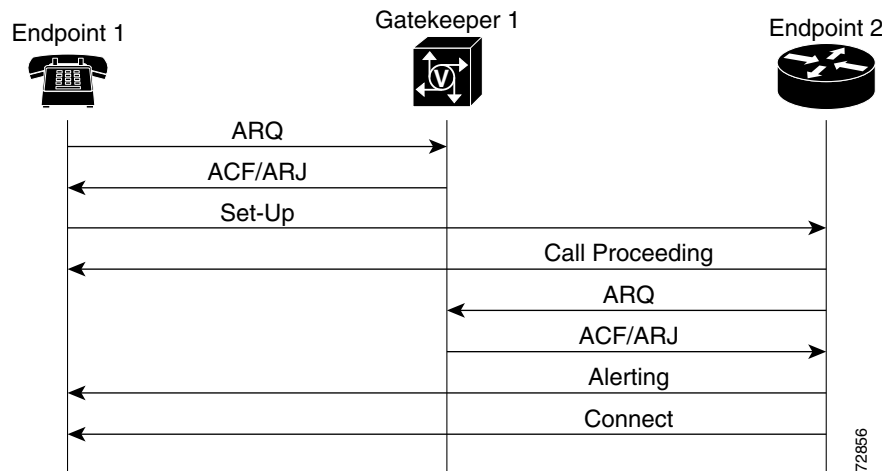

Table D-3 Action Descriptions

| Step | Action                                                                                               | Description                                                                                                                                                                                                                               |
|------|------------------------------------------------------------------------------------------------------|-------------------------------------------------------------------------------------------------------------------------------------------------------------------------------------------------------------------------------------------|
| 1.   | Local Admission Request (ARQ)—Local H.323 endpoint to H.323 gatekeeper                               | Cisco ATA sends a local ARQ message to the H.323 gatekeeper seeking authorization to place a call over the H.323 network.                                                                                                                 |
| 2.   | Local Admission Confirm (ACF) or Admission Reject (ARJ)—H.323 gatekeeper to the local H.323 endpoint | H.323 gatekeeper returns a ACF or ARJ message, indicating whether or not the responding gatekeeper is going to allow the Cisco ATA device access to the network.                                                                          |
| 3.   | Open TCP Channel for Q.931 messaging                                                                 | TCP port 1720 is opened, making way for the forward and reverse flow of Q.931 signaling messages between the H.323 endpoints.                                                                                                             |
| 4.   | Q.931 Call Setup—Local H.323 endpoint to remote H.323 endpoint                                       | Call setup initiates from the local H.323 endpoint.                                                                                                                                                                                       |
| 5.   | Q.931 Call Proceeding—Remote H.323 endpoint to local H.323 endpoint                                  | Remote H.323 endpoint acknowledges call setup initiation.                                                                                                                                                                                 |
| 6.   | Remote Admission Request (ARQ)—Remote Cisco ATA to H.323 gatekeeper                                  | (Somewhat simultaneous, chronologically, to call setup and call proceeding) remote H.323 endpoint contacts the common H.323 gatekeeper, seeking authorization to complete the two-way H.323 network call.                                 |
| 7.   | Remote Admission Confirm (ACF) or Admission Reject (ARJ)—H.323 gatekeeper to the remote Cisco ATA    | H.323 gatekeeper returns a ACF or ARJ message, indicating whether or not the responding gatekeeper is going to allow the Cisco ATA device access to the network.                                                                          |
| 8.   | Q.931 Alerting—Remote H.323 endpoint to local H.323 endpoint                                         | Status message is sent to calling H.323 endpoint advising that the called party has been notified (phone ringing).                                                                                                                        |
| 9.   | Q.931 Connect—Remote H.323 endpoint to local H.323 endpoint                                          | Status message is sent to calling H.323 endpoint advising that the called party has answered the call (phone off hook).                                                                                                                   |
| 10.  | Open TCP Channel for H.245                                                                           | Dynamically assigned TCP port is opened on both the local and remote H.323 endpoints, allowing for subsequent call setup activities (transmission and reception capability exchange, master-slave relationship determination, and so on). |
| 11.  | H.245 Terminal Capabilities                                                                          | Various endpoint transmission and reception capabilities defining operation of voice, video, and data are exchanged and acknowledged to ensure consistent, reliable two-way communication between endpoints.                              |
| 12.  | H.245 Terminal Capabilities                                                                          |                                                                                                                                                                                                                                           |
| 13.  | H.245 Terminal Capabilities                                                                          |                                                                                                                                                                                                                                           |
| 14.  | H.245 Terminal Capabilities                                                                          |                                                                                                                                                                                                                                           |
| 15.  | Exchange of Master-Slave Determination Messages—Remote H.323 endpoint to local H.323 endpoint        | Determines master and slave assignments between H.323 endpoints.                                                                                                                                                                          |
| 16.  | H.245 Open Audio Logical Channel—Local H.323 endpoint to remote H.323 endpoint                       | Before actual transmission or reception of voice, video, or data, notification that the primary logical channel for the local H.323 endpoint has been opened, ensuring clear two-way communication.                                       |
| 17.  | H.245 Open Audio Logical Channel Acknowledgement—Remote H.323 endpoint to local H.323 endpoint       | Remote H.323 endpoint acknowledges readiness.                                                                                                                                                                                             |

Table D-3 Action Descriptions (continued)

| Step | Action                                                                                         | Description                                                                                                                                                                                          |
|------|------------------------------------------------------------------------------------------------|------------------------------------------------------------------------------------------------------------------------------------------------------------------------------------------------------|
| 18.  | H.245 Open Audio Logical Channel—Remote H.323 endpoint to local H.323 endpoint                 | Before actual transmission or reception of voice, video, or data, notification that the primary logical channel for the remote H.323 endpoint has been opened, ensuring clear two-way communication. |
| 19.  | H.245 Open Audio Logical Channel Acknowledgement—Local H.323 endpoint to remote H.323 endpoint | Local H.323 endpoint acknowledges readiness.                                                                                                                                                         |
| 20.  | Bi-Directional Audio with Transcoding in the Endpoints                                         | Two-way communication ensues between endpoints over the H.323 network.                                                                                                                               |

Table D-4 Log Listings

|    |                                                                                                                                                                                                                                                                                                                                                                                                                                                                                                                                                                                                  |
|----|--------------------------------------------------------------------------------------------------------------------------------------------------------------------------------------------------------------------------------------------------------------------------------------------------------------------------------------------------------------------------------------------------------------------------------------------------------------------------------------------------------------------------------------------------------------------------------------------------|
| 1. | <pre> value RasMessage ::= registrationRequest : {   requestSeqNum 61357   protocolIdentifier { 0 0 8 2250 0 2 }   discoveryComplete FALSE   callSignalAddress   {   }   rasAddress   {     ipAddress :     {       ip 'COA80363'H       port 49450     }   }   terminalType   {     mc FALSE     undefinedNode FALSE   }   gatekeeperIdentifier {"zonetwo"}   endpointVendor   {     vendor     {       t35CountryCode 181       t35Extension 0       manufacturerCode 18     }   }   timeToLive 60   keepAlive TRUE   endpointIdentifier {"814EE09C0000001A"}   willSupplyUUIEs FALSE } </pre> |
| 2. | <pre> value RasMessage ::= registrationConfirm : {   requestSeqNum 61357   protocolIdentifier { 0 0 8 2250 0 2 }   callSignalAddress   {   }   gatekeeperIdentifier {"zonetwo"}   endpointIdentifier {"814EE09C0000001A"}   alternateGatekeeper   {   }   timeToLive 60   willRespondToIRR FALSE } </pre>                                                                                                                                                                                                                                                                                        |

Table D-4 Log Listings (continued)

|    |                                                                                                                                                                                                                                                                                                                                                                                                                                                                                                                                                                                                                                                                                                                                                                                                                                                                                                                                                                                                                                                                                                                                                                                                                                                                                                                                                                                                                      |
|----|----------------------------------------------------------------------------------------------------------------------------------------------------------------------------------------------------------------------------------------------------------------------------------------------------------------------------------------------------------------------------------------------------------------------------------------------------------------------------------------------------------------------------------------------------------------------------------------------------------------------------------------------------------------------------------------------------------------------------------------------------------------------------------------------------------------------------------------------------------------------------------------------------------------------------------------------------------------------------------------------------------------------------------------------------------------------------------------------------------------------------------------------------------------------------------------------------------------------------------------------------------------------------------------------------------------------------------------------------------------------------------------------------------------------|
| 3. | <pre> value H323_UserInformation ::= {   h323-uu-pdu   {     h323-message-body setup :     {       protocolIdentifier { 0 0 8 2250 0 2 }       sourceAddress       {         h323-ID :{"Firstname Lastname"}       }       sourceInfo       {         vendor         {           vendor           {             t35CountryCode 181             t35Extension 0             manufacturerCode 21324           }           productId '4D6963726F736F6674AE204E65744D656574696E...'H           versionId '332E3000'H         }         terminal         {           mc FALSE           undefinedNode FALSE         }         destinationAddress         {           e164 : "6661111"         }         activeMC FALSE         conferenceID '2E9B85298E88D611AD4600A0CC5C89F1'H         conferenceGoal create :NULL         callType pointToPoint :NULL         sourceCallSignalAddress ipAddress :         {           ip 'COA80209'H           port 4568         }         callIdentifier         {           guid '2D9B85298E88D611AD4600A0CC5C89F1'H         }         mediaWaitForConnect FALSE         canOverlapSend FALSE       }       nonStandardData       {         nonStandardIdentifier h221NonStandard :         {           t35CountryCode 181           t35Extension 0           manufacturerCode 21324         }         data '02000000280000000000000001B00000081384274...'H       }     }   } } </pre> |
| 4. | <pre> value ARQnonStandardInfo ::= {   sourceAlias   {   }   sourceExtAlias   {   }   displayInformationElement "Firstname Lastname"   interfaceSpecificBillingId "FXS 1/1/0" } </pre>                                                                                                                                                                                                                                                                                                                                                                                                                                                                                                                                                                                                                                                                                                                                                                                                                                                                                                                                                                                                                                                                                                                                                                                                                               |



Table D-4 Log Listings (continued)

|    |                                                                                                                                                                                                                                                                                                                                                                                                                                                                                                                                                                                                                                                                                                                                                                                                                                      |
|----|--------------------------------------------------------------------------------------------------------------------------------------------------------------------------------------------------------------------------------------------------------------------------------------------------------------------------------------------------------------------------------------------------------------------------------------------------------------------------------------------------------------------------------------------------------------------------------------------------------------------------------------------------------------------------------------------------------------------------------------------------------------------------------------------------------------------------------------|
| 5. | <pre> value RasMessage ::= admissionRequest : {   requestSeqNum 61358   callType pointToPoint :NULL   callModel direct :NULL   endpointIdentifier {"814EE09C0000001A"}   destinationInfo   {     e164 : "66611111"   }   srcInfo   {     h323-ID : {"Firstname Lastname"}   }   srcCallSignalAddress ipAddress :   {     ip 'COA80209'H     port 4568   }   bandwidth 640   callReferenceValue 215   nonStandardData   {     nonStandardIdentifier h221NonStandard :     {       t35CountryCode 181       t35Extension 0       manufacturerCode 18     }     data '8000000860132246697273746E616D65204C6173...'H   }   conferenceID '2E9B85298E88D611AD4600A0CC5C89F1'H   activeMC FALSE   answerCall TRUE   canMapAlias TRUE   callIdentifier   {     guid '2D9B85298E88D611AD4600A0CC5C89F1'H   }   willSupplyUUIEs FALSE } </pre> |
| 6. | <pre> value RasMessage ::= admissionConfirm : {   requestSeqNum 61358   bandwidth 1   callModel direct :NULL   destCallSignalAddress ipAddress :   {     ip 'COA80363'H     port 1720   }   irrFrequency 240   willRespondToIRR FALSE   uuiEsRequested   {     setup FALSE     callProceeding FALSE     connect FALSE     alerting FALSE     information FALSE     releaseComplete FALSE     facility FALSE     progress FALSE     empty FALSE   } } </pre>                                                                                                                                                                                                                                                                                                                                                                          |

Table D-4 Log Listings (continued)

|    |                                                                                                                                                                                                                                                                                                                                                                                                                                                                                                                                                                                                                                                                                                           |
|----|-----------------------------------------------------------------------------------------------------------------------------------------------------------------------------------------------------------------------------------------------------------------------------------------------------------------------------------------------------------------------------------------------------------------------------------------------------------------------------------------------------------------------------------------------------------------------------------------------------------------------------------------------------------------------------------------------------------|
| 7. | <pre> value H323_UserInformation ::= {   h323-uu-pdu   {     h323-message-body callProceeding :     {       protocolIdentifier { 0 0 8 2250 0 2 }       destinationInfo       {         mc FALSE         undefinedNode FALSE       }       h245Address ipAddress :       {         ip 'COA80363'H         port 11201       }       callIdentifier       {         guid '2D9B85298E88D611AD4600A0CC5C89F1'H       }     }     h245Tunneling FALSE   } } </pre>                                                                                                                                                                                                                                             |
| 8. | <pre> value H323_UU_NonStdInfo ::= {   version 16   protoParam qsigNonStdInfo :   {     iei 30     rawMesg '1E028188'H   } } </pre>                                                                                                                                                                                                                                                                                                                                                                                                                                                                                                                                                                       |
| 9. | <pre> value H323_UserInformation ::= {   h323-uu-pdu   {     h323-message-body progress :     {       protocolIdentifier { 0 0 8 2250 0 2 }       destinationInfo       {         mc FALSE         undefinedNode FALSE       }       h245Address ipAddress :       {         ip 'COA80363'H         port 11201       }       callIdentifier       {         guid '2D9B85298E88D611AD4600A0CC5C89F1'H       }     }     h245Tunneling FALSE     nonStandardControl     {       {         nonStandardIdentifier h221NonStandard :         {           t35CountryCode 181           t35Extension 0           manufacturerCode 18         }         data '60011000011E041E028188'H       }     }   } } </pre> |

Table D-4 Log Listings (continued)

|     |                                                                                                                                                                                                                                                                                                                                                                                                                                                                                                                                                                                                                                                                                                                                                                                                                                                                                                                                                                                                                                                                     |
|-----|---------------------------------------------------------------------------------------------------------------------------------------------------------------------------------------------------------------------------------------------------------------------------------------------------------------------------------------------------------------------------------------------------------------------------------------------------------------------------------------------------------------------------------------------------------------------------------------------------------------------------------------------------------------------------------------------------------------------------------------------------------------------------------------------------------------------------------------------------------------------------------------------------------------------------------------------------------------------------------------------------------------------------------------------------------------------|
| 10. | <pre> value H323_UU_NonStdInfo ::= {   version 0   progIndParam progIndIEInfo :   {     progIndIE '00000002'H   } } </pre>                                                                                                                                                                                                                                                                                                                                                                                                                                                                                                                                                                                                                                                                                                                                                                                                                                                                                                                                          |
| 11. | <pre> value H323_UserInformation ::= {   h323-uu-pdu   {     h323-message-body connect :     {       protocolIdentifier { 0 0 8 2250 0 2 }       h245Address ipAddress :       {         ip 'COA80363'H         port 11201       }       destinationInfo       {         gateway         {           protocol           {             voice :             {               supportedPrefixes               {                 {                   prefix e164 : "1#"                 }               }             }           }         }         mc FALSE         undefinedNode FALSE       }       conferenceID '2E9B85298E88D611AD4600A0CC5C89F1'H       callIdentifier       {         guid '2D9B85298E88D611AD4600A0CC5C89F1'H       }       h245Tunneling FALSE       nonStandardControl       {         {           nonStandardIdentifier h221NonStandard :           {             t35CountryCode 181             t35Extension 0             manufacturerCode 18           }           data 'C00100028006000400000002'H         }       }     }   } } </pre> |
| 12. | <pre> value IRRperCallnonStandardInfo ::= {   startTime 1024959117 } </pre>                                                                                                                                                                                                                                                                                                                                                                                                                                                                                                                                                                                                                                                                                                                                                                                                                                                                                                                                                                                         |

Table D-4 Log Listings (continued)

```

13. value RasMessage ::= infoRequestResponse :
 {
 requestSeqNum 61359
 endpointType
 {
 gateway
 {
 protocol
 {
 voice :
 {
 supportedPrefixes
 {
 {
 prefix e164 : "1#"
 }
 }
 }
 }
 }
 }
 mc FALSE
 undefinedNode FALSE
 }
 endpointIdentifier {"814EE09C0000001A"}
 rasAddress ipAddress :
 {
 ip 'COA80363'H
 port 49450
 }
 callSignalAddress
 {
 ipAddress :
 {
 ip 'COA80363'H
 port 1720
 }
 }
 endpointAlias
 {
 e164 : "6661111",
 e164 : "6663333",
 h323-ID : {"zonetwo"}
 }
 perCallInfo
 {
 {
 nonStandardData
 {
 nonStandardIdentifier h221NonStandard :
 {
 t35CountryCode 181
 t35Extension 0
 manufacturerCode 18
 }
 data '703D17A28D'H
 }
 callReferenceValue 215
 conferenceID '2E9B85298E88D611AD4600A0CC5C89F1'H
 h245
 {
 }
 callSignaling
 {
 }
 callType pointToPoint : NULL
 bandwidth 1
 callModel direct : NULL
 callIdentifier
 {
 guid '2D9B85298E88D611AD4600A0CC5C89F1'H
 }
 }
 }
 needResponse FALSE
}

```

Table D-4 Log Listings (continued)

|     |                                                                                                                                                                                                                                                                                                                                   |
|-----|-----------------------------------------------------------------------------------------------------------------------------------------------------------------------------------------------------------------------------------------------------------------------------------------------------------------------------------|
| 14. | <pre> value H323_UserInformation ::= {   h323-uu-pdu   {     h323-message-body releaseComplete :     {       protocolIdentifier { 0 0 8 2250 0 2 }       reason undefinedReason :NULL       callIdentifier       {         guid '2D9B85298E88D611AD4600A0CC5C89F1'H       }     }   } } </pre>                                    |
| 15. | <pre> value RasMessage ::= disengageRequest : {   requestSeqNum 61360   endpointIdentifier {"814EE09C0000001A"}   conferenceID '2E9B85298E88D611AD4600A0CC5C89F1'H   callReferenceValue 215   disengageReason normalDrop :NULL   callIdentifier   {     guid '2D9B85298E88D611AD4600A0CC5C89F1'H   }   answeredCall TRUE } </pre> |
| 16. | <pre> value RasMessage ::= disengageConfirm : {   requestSeqNum 61360 } </pre>                                                                                                                                                                                                                                                    |

Table D-4 Log Listings (continued)

|     |                                                                                                                                                                                                                                                                                                                                                                                                                                                                                                                                                                                                 |
|-----|-------------------------------------------------------------------------------------------------------------------------------------------------------------------------------------------------------------------------------------------------------------------------------------------------------------------------------------------------------------------------------------------------------------------------------------------------------------------------------------------------------------------------------------------------------------------------------------------------|
| 17. | <pre> value RasMessage ::= registrationRequest : {   requestSeqNum 61361   protocolIdentifier { 0 0 8 2250 0 2 }   discoveryComplete FALSE   callSignalAddress   {   }   rasAddress   {     ipAddress :     {       ip 'C0A80363'H       port 49450     }   }   terminalType   {     mc FALSE     undefinedNode FALSE   }   gatekeeperIdentifier {"zonetwo"}   endpointVendor   {     vendor     {       t35CountryCode 181       t35Extension 0       manufacturerCode 18     }   }   timeToLive 60   keepAlive TRUE   endpointIdentifier {"814EE09C0000001A"}   willSupplyUIEs FALSE } </pre> |
| 18. | <pre> value RasMessage ::= registrationConfirm : {   requestSeqNum 61361   protocolIdentifier { 0 0 8 2250 0 2 }   callSignalAddress   {   }   gatekeeperIdentifier {"zonetwo"}   endpointIdentifier {"814EE09C0000001A"}   alternateGatekeeper   {   }   timeToLive 60   willRespondToIRR FALSE } </pre>                                                                                                                                                                                                                                                                                       |

## H.323 Call Setup from H.323 Network to Circuit Switched Network

Figure D-3 illustrates a Cisco ATA initiating a connection to a Circuit Switched Network (CSN) or Public Switched Telephone Network (PSTN) Gateway router through its local H.323 gatekeeper.



### Note

This scenario assumes that the H.323 configuration employs Fast Start Signaling with tunneling capability.

Figure D-3 H.323 Call Setup from H.323 Network to Circuit Switched Network

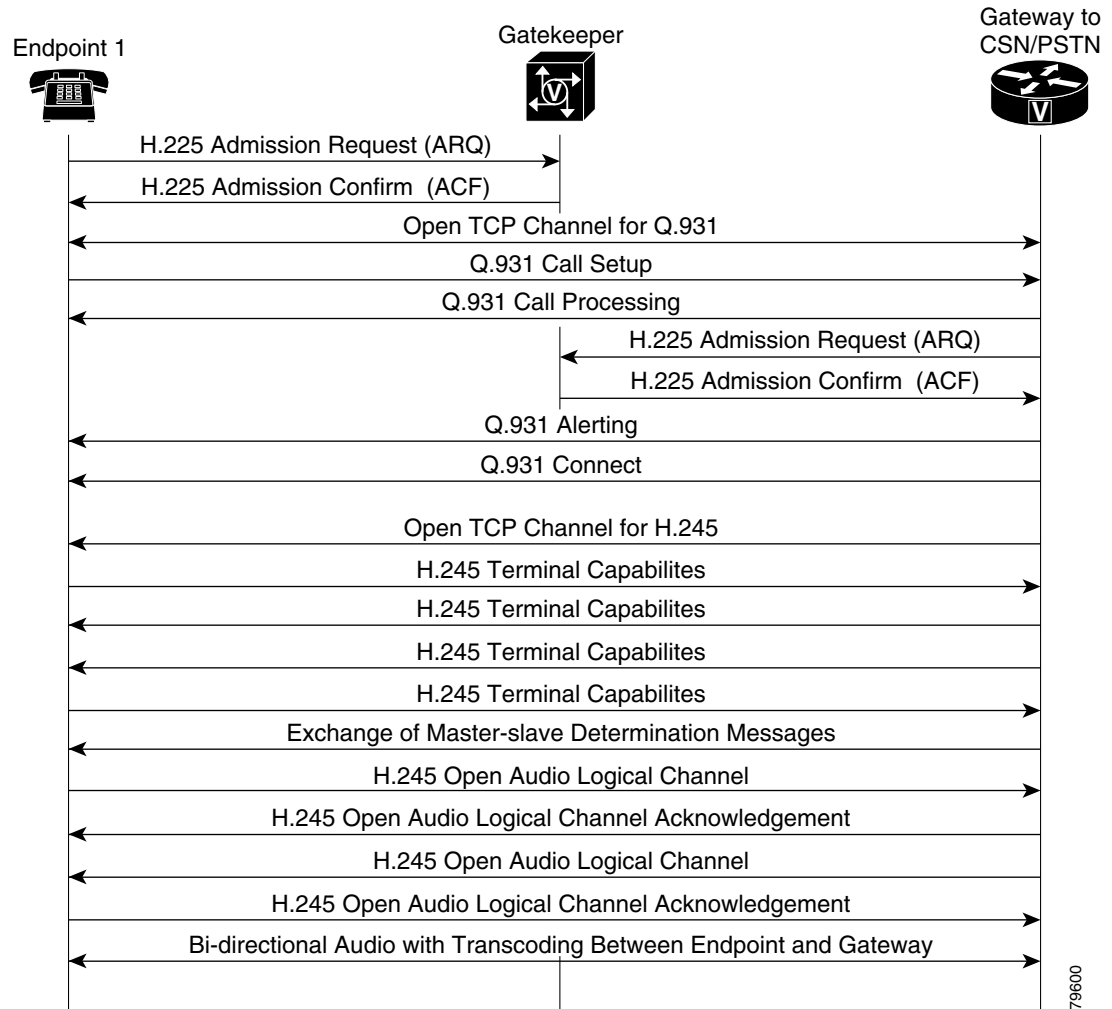

79600

Table D-5 Action Descriptions

| Step | Action                                                                                         | Description                                                                                                                                                      |
|------|------------------------------------------------------------------------------------------------|------------------------------------------------------------------------------------------------------------------------------------------------------------------|
| 1.   | Local Admission Request (ARQ)—Local endpoint to H.323 gatekeeper                               | Cisco ATA sends a local ARQ message to the H.323 gatekeeper seeking authorization to place a call over the H.323 network.                                        |
| 2.   | Local Admission Confirm (ACF) or Admission Reject (ARJ)—H.323 gatekeeper to the local endpoint | H.323 gatekeeper returns a ACF or ARJ message, indicating whether or not the responding gatekeeper is going to allow the Cisco ATA device access to the network. |
| 3.   | Open TCP Channel for Q.931 messaging                                                           | TCP port 1720 is opened, making way for the forward and reverse flow of Q.931 signaling messages between the H.323 endpoint and the CSN/PSTN Gateway.            |
| 4.   | Q.931 Call Setup—Local H.323 endpoint to remote H.323 endpoint                                 | Call setup initiates from the local H.323 endpoint.                                                                                                              |
| 5.   | Q.931 Call Proceeding—Remote H.323 endpoint to local H.323 endpoint                            | Gateway acknowledges call setup initiation.                                                                                                                      |

Table D-5 Action Descriptions (continued)

| Step | Action                                                                                         | Description                                                                                                                                                                                                                                   |
|------|------------------------------------------------------------------------------------------------|-----------------------------------------------------------------------------------------------------------------------------------------------------------------------------------------------------------------------------------------------|
| 6.   | Gateway Admission Request (ARQ)—CSN/PSTN Gateway to H.323 gatekeeper                           | (Somewhat simultaneous, chronologically, to call setup and call proceeding) Gateway contacts the common H.323 gatekeeper, seeking authorization to complete the two-way H.323 network-to-CSN/PSTN Gateway call.                               |
| 7.   | Gateway Admission Confirm (ACF) or Admission Reject (ARJ)—H.323 gatekeeper to CSN/PSTN Gateway | H.323 gatekeeper returns a ACF or ARJ message, indicating whether or not the responding gatekeeper is going to allow the Gateway access to the network.                                                                                       |
| 8.   | Q.931 Alerting—Gateway endpoint to local H.323 endpoint                                        | Status message is sent to calling H.323 endpoint advising that the called party has been notified (phone ringing).                                                                                                                            |
| 9.   | Q.931 Connect—Gateway to local H.323 endpoint                                                  | Status message is sent to calling H.323 endpoint advising that the called party has answered the call (phone off hook).                                                                                                                       |
| 10.  | Open TCP Channel for H.245                                                                     | Dynamically assigned TCP port is opened on both the local H.323 endpoint and the Gateway, allowing for subsequent call setup activities (transmission and reception capability exchange, master-slave relationship determination, and so on). |
| 11.  | H.245 Terminal Capabilities                                                                    | Various endpoint transmission and reception capabilities defining operation of voice, video, and data are exchanged and acknowledged to ensure consistent, reliable two-way communication between the H.323 endpoint and the Gateway.         |
| 12.  | H.245 Terminal Capabilities                                                                    |                                                                                                                                                                                                                                               |
| 13.  | H.245 Terminal Capabilities                                                                    |                                                                                                                                                                                                                                               |
| 14.  | H.245 Terminal Capabilities                                                                    |                                                                                                                                                                                                                                               |
| 15.  | Exchange of Master-Slave Determination Messages—Remote H.323 endpoint to local H.323 endpoint  | Determines master and slave assignments between the H.323 endpoint and the Gateway.                                                                                                                                                           |
| 16.  | H.245 Open Audio Logical Channel—Local H.323 endpoint to remote H.323 endpoint                 | Before actual transmission or reception of voice, video, or data, notification that the primary logical channel for the local H.323 endpoint has been opened, ensuring clear two-way communication.                                           |
| 17.  | H.245 Open Audio Logical Channel Acknowledgement—Remote H.323 endpoint to local H.323 endpoint | Gateway acknowledges readiness.                                                                                                                                                                                                               |
| 18.  | H.245 Open Audio Logical Channel—Remote H.323 endpoint to local H.323 endpoint                 | Before actual transmission or reception of voice, video, or data, notification that the primary logical channel for the Gateway has been opened, ensuring clear two-way communication.                                                        |
| 19.  | H.245 Open Audio Logical Channel Acknowledgement—Local H.323 endpoint to remote H.323 endpoint | Local H.323 endpoint acknowledges readiness.                                                                                                                                                                                                  |
| 20.  | Bi-Directional Audio with Transcoding Between Endpoint and Gateway                             | Two-way communication ensues between the local H.323 endpoint and the CSN/PSTN Gateway.                                                                                                                                                       |



Table D-6 Log Listings

|    |                                                                                                                                                                                                                                                                                                                                                                                                                                                                                                                                                                                                  |
|----|--------------------------------------------------------------------------------------------------------------------------------------------------------------------------------------------------------------------------------------------------------------------------------------------------------------------------------------------------------------------------------------------------------------------------------------------------------------------------------------------------------------------------------------------------------------------------------------------------|
| 1. | <pre> value RasMessage ::= registrationRequest : {   requestSeqNum 28034   protocolIdentifier { 0 0 8 2250 0 2 }   discoveryComplete FALSE   callSignalAddress   {   }   rasAddress   {     ipAddress :     {       ip 'COA80363'H       port 49450     }   }   terminalType   {     mc FALSE     undefinedNode FALSE   }   gatekeeperIdentifier {"zonetwo"}   endpointVendor   {     vendor     {       t35CountryCode 181       t35Extension 0       manufacturerCode 18     }   }   timeToLive 60   keepAlive TRUE   endpointIdentifier {"814EE09C0000001A"}   willSupplyUUIEs FALSE } </pre> |
| 2. | <pre> value RasMessage ::= registrationConfirm : {   requestSeqNum 28034   protocolIdentifier { 0 0 8 2250 0 2 }   callSignalAddress   {   }   gatekeeperIdentifier {"zonetwo"}   endpointIdentifier {"814EE09C0000001A"}   alternateGatekeeper   {   }   timeToLive 60   willRespondToIRR FALSE } </pre>                                                                                                                                                                                                                                                                                        |

Table D-6 Log Listings (continued)

|    |                                                                                                                                                                                                                                                                                                                                                                                                                                                                                                                                                                                                                                                                                                                                                                                                                                                                                                                                                                                                                                                                                                                                                                                                                                                                                                                                                                                                                           |
|----|---------------------------------------------------------------------------------------------------------------------------------------------------------------------------------------------------------------------------------------------------------------------------------------------------------------------------------------------------------------------------------------------------------------------------------------------------------------------------------------------------------------------------------------------------------------------------------------------------------------------------------------------------------------------------------------------------------------------------------------------------------------------------------------------------------------------------------------------------------------------------------------------------------------------------------------------------------------------------------------------------------------------------------------------------------------------------------------------------------------------------------------------------------------------------------------------------------------------------------------------------------------------------------------------------------------------------------------------------------------------------------------------------------------------------|
| 3. | <pre> value H323_UserInformation ::= {   h323-uu-pdu   {     h323-message-body setup :     {       protocolIdentifier { 0 0 8 2250 0 2 }       sourceAddress       {         h323-ID :{"Firstname Lastname"}       }       sourceInfo       {         vendor         {           vendor           {             t35CountryCode 181             t35Extension 0             manufacturerCode 21324           }           productId '4D6963726F736F6674AE204E65744D656574696E...'H           versionId '332E3000'H         }         terminal         {           mc FALSE           undefinedNode FALSE         }         destinationAddress         {           e164 : "914089023833"         }         activeMC FALSE         conferenceID '0C01EF01BD95D611AD4600A0CC5C89F1'H         conferenceGoal create :NULL         callType pointToPoint :NULL         sourceCallSignalAddress ipAddress :         {           ip 'COA80209'H           port 4595         }         callIdentifier         {           guid '0B01EF01BD95D611AD4600A0CC5C89F1'H         }         mediaWaitForConnect FALSE         canOverlapSend FALSE       }       nonStandardData       {         nonStandardIdentifier h221NonStandard :         {           t35CountryCode 181           t35Extension 0           manufacturerCode 21324         }         data '02000000280000000000000001B00000081384274...'H       }     }   } } </pre> |
| 4. | <pre> value ARQnonStandardInfo ::= {   sourceAlias   {   }   sourceExtAlias   {   }   displayInformationElement "Firstname Lastname"   interfaceSpecificBillingId "FXS 1/1/1" } </pre>                                                                                                                                                                                                                                                                                                                                                                                                                                                                                                                                                                                                                                                                                                                                                                                                                                                                                                                                                                                                                                                                                                                                                                                                                                    |

Table D-6 Log Listings (continued)

|    |                                                                                                                                                                                                                                                                                                                                                                                                                                                                                                                                                                                                                                                                                                                                                                                                                                          |
|----|------------------------------------------------------------------------------------------------------------------------------------------------------------------------------------------------------------------------------------------------------------------------------------------------------------------------------------------------------------------------------------------------------------------------------------------------------------------------------------------------------------------------------------------------------------------------------------------------------------------------------------------------------------------------------------------------------------------------------------------------------------------------------------------------------------------------------------------|
| 5. | <pre> value RasMessage ::= admissionRequest : {   requestSeqNum 28037   callType pointToPoint :NULL   callModel direct :NULL   endpointIdentifier {"814EE09C0000001A"}   destinationInfo   {     e164 : "914089023833"   }   srcInfo   {     h323-ID : {"Firstname Lastname"}   }   srcCallSignalAddress ipAddress :   {     ip 'C0A80209'H     port 4595   }   bandwidth 640   callReferenceValue 235   nonStandardData   {     nonStandardIdentifier h221NonStandard :     {       t35CountryCode 181       t35Extension 0       manufacturerCode 18     }     data '8000000860132246697273746E616D65204C6173...'H   }   conferenceID '0C01EF01BD95D611AD4600A0CC5C89F1'H   activeMC FALSE   answerCall TRUE   canMapAlias TRUE   callIdentifier   {     guid '0B01EF01BD95D611AD4600A0CC5C89F1'H   }   willSupplyUUIEs FALSE } </pre> |
| 6. | <pre> value RasMessage ::= admissionConfirm : {   requestSeqNum 28037   bandwidth 1   callModel direct :NULL   destCallSignalAddress ipAddress :   {     ip 'C0A80363'H     port 1720   }   irrFrequency 240   willRespondToIRR FALSE   uuiesRequested   {     setup FALSE     callProceeding FALSE     connect FALSE     alerting FALSE     information FALSE     releaseComplete FALSE     facility FALSE     progress FALSE     empty FALSE   } } </pre>                                                                                                                                                                                                                                                                                                                                                                              |

Table D-6 Log Listings (continued)

|    |                                                                                                                                                                                                                                                                                                                                                                                                                                                                                                                                                                                                                                                                                                           |
|----|-----------------------------------------------------------------------------------------------------------------------------------------------------------------------------------------------------------------------------------------------------------------------------------------------------------------------------------------------------------------------------------------------------------------------------------------------------------------------------------------------------------------------------------------------------------------------------------------------------------------------------------------------------------------------------------------------------------|
| 7. | <pre> value H323_UserInformation ::= {   h323-uu-pdu   {     h323-message-body callProceeding :     {       protocolIdentifier { 0 0 8 2250 0 2 }       destinationInfo       {         mc FALSE         undefinedNode FALSE       }       h245Address ipAddress :       {         ip 'COA80363'H         port 11218       }       callIdentifier       {         guid '0B01EF01BD95D611AD4600A0CC5C89F1'H       }     }     h245Tunneling FALSE   } } </pre>                                                                                                                                                                                                                                             |
| 8. | <pre> value H323_UU_NonStdInfo ::= {   version 16   protoParam qsigNonStdInfo :   {     iei 30     rawMesg '1E028188'H   } } </pre>                                                                                                                                                                                                                                                                                                                                                                                                                                                                                                                                                                       |
| 9. | <pre> value H323_UserInformation ::= {   h323-uu-pdu   {     h323-message-body progress :     {       protocolIdentifier { 0 0 8 2250 0 2 }       destinationInfo       {         mc FALSE         undefinedNode FALSE       }       h245Address ipAddress :       {         ip 'COA80363'H         port 11218       }       callIdentifier       {         guid '0B01EF01BD95D611AD4600A0CC5C89F1'H       }     }     h245Tunneling FALSE     nonStandardControl     {       {         nonStandardIdentifier h221NonStandard :         {           t35CountryCode 181           t35Extension 0           manufacturerCode 18         }         data '60011000011E041E028188'H       }     }   } } </pre> |

Table D-6 Log Listings (continued)

```

10. value H323_UserInformation ::=
 {
 h323-uu-pdu
 {
 h323-message-body connect :
 {
 protocolIdentifier { 0 0 8 2250 0 2 }
 h245Address ipAddress :
 {
 ip 'C0A80363'H
 port 11218
 }
 destinationInfo
 {
 gateway
 {
 protocol
 {
 voice :
 {
 supportedPrefixes
 {
 {
 prefix e164 : "1#"
 }
 }
 }
 }
 }
 mc FALSE
 undefinedNode FALSE
 }
 conferenceID '0C01EF01BD95D611AD4600A0CC5C89F1'H
 callIdentifier
 {
 guid '0B01EF01BD95D611AD4600A0CC5C89F1'H
 }
 }
 h245Tunneling FALSE
 nonStandardControl
 {
 {
 nonStandardIdentifier h221NonStandard :
 {
 t35CountryCode 181
 t35Extension 0
 manufacturerCode 18
 }
 data 'C00100028006000400000002'H
 }
 }
 }
 }

```

Table D-6 Log Listings (continued)

```

11. value RasMessage ::= infoRequestResponse :
 {
 requestSeqNum 28038
 endpointType
 {
 gateway
 {
 protocol
 {
 voice :
 {
 supportedPrefixes
 {
 {
 prefix e164 : "1#"
 }
 }
 }
 }
 }
 }
 mc FALSE
 undefinedNode FALSE
 }
 endpointIdentifier {"814EE09C0000001A"}
 rasAddress ipAddress :
 {
 ip 'COA80363'H
 port 49450
 }
 callSignalAddress
 {
 ipAddress :
 {
 ip 'COA80363'H
 port 1720
 }
 }
 endpointAlias
 {
 e164 : "6661111",
 e164 : "6663333",
 h323-ID : {"zonetwo"}
 }
 perCallInfo
 {
 {
 nonStandardData
 {
 nonStandardIdentifier h221NonStandard :
 {
 t35CountryCode 181
 t35Extension 0
 manufacturerCode 18
 }
 data '703D2DC1A0'H
 }
 callReferenceValue 235
 conferenceID '0C01EF01BD95D611AD4600A0CC5C89F1'H
 h245
 {
 }
 callSignaling
 {
 }
 callType pointToPoint : NULL
 bandwidth 1
 callModel direct : NULL
 callIdentifier
 {
 guid '0B01EF01BD95D611AD4600A0CC5C89F1'H
 }
 }
 }
 needResponse FALSE
}

```

**Table D-6 Log Listings (continued)**

|     |                                                                                                                          |
|-----|--------------------------------------------------------------------------------------------------------------------------|
| 12. | <pre>value H323_UU_NonStdInfo ::= {   version 0   progIndParam progIndIEInfo :   {     progIndIE '00000002'H   } }</pre> |
| 13. | <pre>value IRRperCallnonStandardInfo ::= {   startTime 1026408864 }</pre>                                                |

Table D-6 Log Listings (continued)

```

14. value MultimediaSystemControlMessage ::= request :terminalCapabilitySet :
 {
 sequenceNumber 1
 protocolIdentifier { 0 0 8 245 0 3 }
 multiplexCapability h2250Capability :
 {
 maximumAudioDelayJitter 20
 receiveMultipointCapability
 {
 multicastCapability FALSE
 multiUniCastConference FALSE
 mediaDistributionCapability
 {
 {
 centralizedControl FALSE
 distributedControl FALSE
 centralizedAudio FALSE
 distributedAudio FALSE
 centralizedVideo FALSE
 distributedVideo FALSE
 }
 }
 }
 transmitMultipointCapability
 {
 multicastCapability FALSE
 multiUniCastConference FALSE
 mediaDistributionCapability
 {
 {
 centralizedControl FALSE
 distributedControl FALSE
 centralizedAudio FALSE
 distributedAudio FALSE
 centralizedVideo FALSE
 distributedVideo FALSE
 }
 }
 }
 receiveAndTransmitMultipointCapability
 {
 multicastCapability FALSE
 multiUniCastConference FALSE
 mediaDistributionCapability
 {
 {
 centralizedControl FALSE
 distributedControl FALSE
 centralizedAudio FALSE
 distributedAudio FALSE
 centralizedVideo FALSE
 distributedVideo FALSE
 }
 }
 }
 mcCapability
 {
 centralizedConferenceMC FALSE
 decentralizedConferenceMC FALSE
 }
 rtcpVideoControlCapability FALSE
 mediaPacketizationCapability
 {
 h261aVideoPacketization FALSE
 }
 logicalChannelSwitchingCapability FALSE
 t120DynamicPortCapability FALSE
 }
 capabilityTable
 {

```



Table D-6 Log Listings (continued)

|     |                                                                                                                                                                                                                                                                                                                                                                                                                                                                                                                                                                                                                                                                                                                                                                                                                                                                                                                                                                           |
|-----|---------------------------------------------------------------------------------------------------------------------------------------------------------------------------------------------------------------------------------------------------------------------------------------------------------------------------------------------------------------------------------------------------------------------------------------------------------------------------------------------------------------------------------------------------------------------------------------------------------------------------------------------------------------------------------------------------------------------------------------------------------------------------------------------------------------------------------------------------------------------------------------------------------------------------------------------------------------------------|
|     | <pre> {   capabilityTableEntryNumber 17   capability receiveAndTransmitDataApplicationCapability :   {     application nonStandard :     {       nonStandardIdentifier h221NonStandard :       {         t35CountryCode 181         t35Extension 0         manufacturerCode 18       }       data '52747044746D6652656C6179'H     }     maxBitRate 0   } }, {   capabilityTableEntryNumber 23   capability receiveUserInputCapability :hookflash :NULL }, {   capabilityTableEntryNumber 22   capability receiveUserInputCapability :dtmf :NULL }, {   capabilityTableEntryNumber 19   capability receiveUserInputCapability :basicString :NULL }, {   capabilityTableEntryNumber 2   capability receiveAudioCapability :g711Alaw64k :20 } } capabilityDescriptors {   {     capabilityDescriptorNumber 1     simultaneousCapabilities     {       {         23       },       {         22,         19,         17       },       {         2       }     }   } } </pre> |
| 15. | <pre> value MultimediaSystemControlMessage ::= request :masterSlaveDetermination : {   terminalType 60   statusDeterminationNumber 5917 } </pre>                                                                                                                                                                                                                                                                                                                                                                                                                                                                                                                                                                                                                                                                                                                                                                                                                          |

Table D-6 Log Listings (continued)

```

16. value MultimediaSystemControlMessage ::= request :terminalCapabilitySet :
 {
 sequenceNumber 1
 protocolIdentifier { 0 0 8 245 0 3 }
 multiplexCapability h2250Capability :
 {
 maximumAudioDelayJitter 60
 receiveMultipointCapability
 {
 multicastCapability FALSE
 multiUniCastConference FALSE
 mediaDistributionCapability
 {
 {
 centralizedControl FALSE
 distributedControl FALSE
 centralizedAudio FALSE
 distributedAudio FALSE
 centralizedVideo FALSE
 distributedVideo FALSE
 }
 }
 }
 transmitMultipointCapability
 {
 multicastCapability FALSE
 multiUniCastConference FALSE
 mediaDistributionCapability
 {
 {
 centralizedControl FALSE
 distributedControl FALSE
 centralizedAudio FALSE
 distributedAudio FALSE
 centralizedVideo FALSE
 distributedVideo FALSE
 }
 }
 }
 receiveAndTransmitMultipointCapability
 {
 multicastCapability FALSE
 multiUniCastConference FALSE
 mediaDistributionCapability
 {
 {
 centralizedControl FALSE
 distributedControl FALSE
 centralizedAudio FALSE
 distributedAudio FALSE
 centralizedVideo FALSE
 distributedVideo FALSE
 }
 }
 }
 mcCapability
 {
 centralizedConferenceMC FALSE
 decentralizedConferenceMC FALSE
 }
 rtcpVideoControlCapability FALSE
 mediaPacketizationCapability
 {
 h261aVideoPacketization FALSE
 }
 }
 capabilityTable
 }

```

Table D-6 Log Listings (continued)

```

{
 capabilityTableEntryNumber 32768
 capability nonStandard :
 {
 nonStandardIdentifier h221NonStandard :
 {
 t35CountryCode 181
 t35Extension 66
 manufacturerCode 32896
 }
 data '01'H
 }
},
{
 capabilityTableEntryNumber 15
 capability receiveAndTransmitDataApplicationCapability :
 {
 application t120 :separateLANStack :NULL
 maxBitRate 621700
 }
},
{
 capabilityTableEntryNumber 1
 capability receiveAudioCapability :nonStandard :
 {
 nonStandardIdentifier h221NonStandard :
 {
 t35CountryCode 181
 t35Extension 0
 manufacturerCode 21324
 }
 data '020000000000F4010000F4010100040000000000...'H
 }
},
{
 capabilityTableEntryNumber 2
 capability receiveAudioCapability :g711Alaw64k :180
},
{
 capabilityTableEntryNumber 3
 capability receiveAudioCapability :g711Ulaw64k :180
},
{
 capabilityTableEntryNumber 4
 capability receiveAudioCapability :nonStandard :
 {
 nonStandardIdentifier h221NonStandard :
 {
 t35CountryCode 181
 t35Extension 0
 manufacturerCode 21324
 }
 data '020000000000A0000000A000040010000000000...'H
 }
},
{
 capabilityTableEntryNumber 5
 capability receiveAudioCapability :nonStandard :
 {
 nonStandardIdentifier h221NonStandard :
 {
 t35CountryCode 181
 t35Extension 0
 manufacturerCode 21324
 }
 data '020000000000A0000000A000040010000000000...'H
 }
},
{
 capabilityTableEntryNumber 6
 capability receiveAudioCapability :nonStandard :
 {
 nonStandardIdentifier h221NonStandard :
 {
 t35CountryCode 181
 t35Extension 0
 manufacturerCode 21324
 }
 }
}

```

Table D-6 Log Listings (continued)

```

}
 data '0200000000008000000080000500140000000000...'H
 }
},
{
 capabilityTableEntryNumber 7
 capability receiveAudioCapability :nonStandard :
 {
 nonStandardIdentifier h221NonStandard :
 {
 t35CountryCode 181
 t35Extension 0
 manufacturerCode 21324
 }
 }
 data '0200000000008000000080000500140000000000...'H
}
},
{
 capabilityTableEntryNumber 8
 capability receiveAudioCapability :g7231 :
 {
 maxAl-sduAudioFrames 12
 silenceSuppression FALSE
 }
},
{
 capabilityTableEntryNumber 10
 capability receiveVideoCapability :h263VideoCapability :
 {
 sqcifMPI 1
 maxBitRate 6217
 unrestrictedVector FALSE
 arithmeticCoding FALSE
 advancedPrediction FALSE
 pbFrames FALSE
 temporalSpatialTradeOffCapability TRUE
 }
},
{
 capabilityTableEntryNumber 11
 capability receiveVideoCapability :h263VideoCapability :
 {
 qcifMPI 1
 maxBitRate 6217
 unrestrictedVector FALSE
 arithmeticCoding FALSE
 advancedPrediction FALSE
 pbFrames FALSE
 temporalSpatialTradeOffCapability TRUE
 }
},
{
 capabilityTableEntryNumber 12
 capability receiveVideoCapability :h263VideoCapability :
 {
 cifMPI 2
 maxBitRate 6217
 unrestrictedVector FALSE
 arithmeticCoding FALSE
 advancedPrediction FALSE
 pbFrames FALSE
 temporalSpatialTradeOffCapability TRUE
 }
},
{
 capabilityTableEntryNumber 13
 capability receiveVideoCapability :h261VideoCapability :
 {
 qcifMPI 1
 temporalSpatialTradeOffCapability TRUE
 maxBitRate 6217
 stillImageTransmission FALSE
 }
},
},

```

Table D-6 Log Listings (continued)

```

{
 capabilityTableEntryNumber 14
 capability receiveVideoCapability :h261VideoCapability :
 {
 cifMPI 2
 temporalSpatialTradeOffCapability TRUE
 maxBitRate 6217
 stillImageTransmission FALSE
 }
}
capabilityDescriptors
{
 {
 capabilityDescriptorNumber 6
 simultaneousCapabilities
 {
 {
 8,
 7,
 5,
 6,
 3,
 2,
 1,
 4
 },
 {
 10
 },
 {
 15
 }
 }
 },
 {
 capabilityDescriptorNumber 7
 simultaneousCapabilities
 {
 {
 8,
 7,
 5,
 6,
 3,
 2,
 1,
 4
 },
 {
 11
 },
 {
 15
 }
 }
 },
 {
 capabilityDescriptorNumber 8
 simultaneousCapabilities
 {

```

Table D-6 Log Listings (continued)

```

{
 8,
 7,
 5,
 6,
 3,
 2,
 1,
 4
},
{
 13
},
{
 15
}
},
{
 capabilityDescriptorNumber 9
 simultaneousCapabilities
 {
 {
 8,
 7,
 5,
 6,
 3,
 2,
 1,
 4
 },
 {
 12
 },
 {
 15
 }
 }
},
{
 capabilityDescriptorNumber 10
 simultaneousCapabilities
 {
 {
 8,
 7,
 5,
 6,
 3,
 2,
 1,
 4
 },
 {
 14
 },
 {
 15
 }
 }
}
}

```

Table D-6 Log Listings (continued)

|     |                                                                                                                                                                                                                                                                                                                                                                                                                                                                                                                                               |
|-----|-----------------------------------------------------------------------------------------------------------------------------------------------------------------------------------------------------------------------------------------------------------------------------------------------------------------------------------------------------------------------------------------------------------------------------------------------------------------------------------------------------------------------------------------------|
| 17. | <pre> value MultimediaSystemControlMessage ::= response :terminalCapabilitySetAck : {   sequenceNumber 1 } </pre>                                                                                                                                                                                                                                                                                                                                                                                                                             |
| 18. | <pre> value MultimediaSystemControlMessage ::= request :masterSlaveDetermination : {   terminalType 50   statusDeterminationNumber 7862592 } </pre>                                                                                                                                                                                                                                                                                                                                                                                           |
| 19. | <pre> value MultimediaSystemControlMessage ::= response :masterSlaveDeterminationAck : {   decision slave :NULL } </pre>                                                                                                                                                                                                                                                                                                                                                                                                                      |
| 20. | <pre> value MultimediaSystemControlMessage ::= response :terminalCapabilitySetAck : {   sequenceNumber 1 } </pre>                                                                                                                                                                                                                                                                                                                                                                                                                             |
| 21. | <pre> value MultimediaSystemControlMessage ::= response :masterSlaveDeterminationAck : {   decision master :NULL } </pre>                                                                                                                                                                                                                                                                                                                                                                                                                     |
| 22. | <pre> value MultimediaSystemControlMessage ::= request :openLogicalChannel : {   forwardLogicalChannelNumber 1   forwardLogicalChannelParameters   {     dataType audioData :g711Alaw64k :20     multiplexParameters h2250LogicalChannelParameters :     {       sessionID 1       mediaControlChannel unicastAddress :iPAddress :       {         network 'COA80363'H         tsapIdentifier 18757       }     }   } } </pre>                                                                                                                |
| 23. | <pre> value MultimediaSystemControlMessage ::= request :openLogicalChannel : {   forwardLogicalChannelNumber 257   forwardLogicalChannelParameters   {     dataType audioData :g711Alaw64k :20     multiplexParameters h2250LogicalChannelParameters :     {       sessionID 1       mediaGuaranteedDelivery FALSE       mediaControlChannel unicastAddress :iPAddress :       {         network 'COA80209'H         tsapIdentifier 49607       }       mediaControlGuaranteedDelivery FALSE       silenceSuppression TRUE     }   } } </pre> |

Table D-6 Log Listings (continued)

|     |                                                                                                                                                                                                                                                                                                                                                                                                                                                                                                                                                                                                 |
|-----|-------------------------------------------------------------------------------------------------------------------------------------------------------------------------------------------------------------------------------------------------------------------------------------------------------------------------------------------------------------------------------------------------------------------------------------------------------------------------------------------------------------------------------------------------------------------------------------------------|
| 24. | <pre> value MultimediaSystemControlMessage ::= response :openLogicalChannelAck : {   forwardLogicalChannelNumber 257   forwardMultiplexAckParameters h2250LogicalChannelAckParameters :   {     sessionID 1     mediaChannel unicastAddress :iPAddress :     {       network 'COA80363'H       tsapIdentifier 18756     }     mediaControlChannel unicastAddress :iPAddress :     {       network 'COA80363'H       tsapIdentifier 18757     }     flowControlToZero FALSE   } } </pre>                                                                                                         |
| 25. | <pre> value MultimediaSystemControlMessage ::= response :openLogicalChannelAck : {   forwardLogicalChannelNumber 1   forwardMultiplexAckParameters h2250LogicalChannelAckParameters :   {     sessionID 1     mediaChannel unicastAddress :iPAddress :     {       network 'COA80209'H       tsapIdentifier 49606     }     mediaControlChannel unicastAddress :iPAddress :     {       network 'COA80209'H       tsapIdentifier 49607     }   } } </pre>                                                                                                                                       |
| 26. | <pre> value RasMessage ::= registrationRequest : {   requestSeqNum 28039   protocolIdentifier { 0 0 8 2250 0 2 }   discoveryComplete FALSE   callSignalAddress   {   }   rasAddress   {     ipAddress :     {       ip 'COA80363'H       port 49450     }   }   terminalType   {     mc FALSE     undefinedNode FALSE   }   gatekeeperIdentifier {"zonetwo"}   endpointVendor   {     vendor     {       t35CountryCode 181       t35Extension 0       manufacturerCode 18     }   }   timeToLive 60   keepAlive TRUE   endpointIdentifier {"814EE09C0000001A"}   willSupplyUIEs FALSE } </pre> |



Table D-6 Log Listings (continued)

|     |                                                                                                                                                                                                                                                                                                                                   |
|-----|-----------------------------------------------------------------------------------------------------------------------------------------------------------------------------------------------------------------------------------------------------------------------------------------------------------------------------------|
| 27. | <pre> value RasMessage ::= registrationConfirm : {   requestSeqNum 28039   protocolIdentifier { 0 0 8 2250 0 2 }   callSignalAddress   {   }   gatekeeperIdentifier {"zonetwo"}   endpointIdentifier {"814EE09C0000001A"}   alternateGatekeeper   {   }   timeToLive 60   willRespondToIRR FALSE } </pre>                         |
| 28. | <pre> value MultimediaSystemControlMessage ::= command :endSessionCommand :disconnect :NULL </pre>                                                                                                                                                                                                                                |
| 29. | <pre> value MultimediaSystemControlMessage ::= command :endSessionCommand :disconnect :NULL </pre>                                                                                                                                                                                                                                |
| 30. | <pre> value H323_UserInformation ::= {   h323-uu-pdu   {     h323-message-body releaseComplete :     {       protocolIdentifier { 0 0 8 2250 0 2 }       reason undefinedReason :NULL       callIdentifier       {         guid '0B01EF01BD95D611AD4600A0CC5C89F1'H       }     }   } } </pre>                                    |
| 31. | <pre> value RasMessage ::= disengageRequest : {   requestSeqNum 28040   endpointIdentifier {"814EE09C0000001A"}   conferenceID '0C01EF01BD95D611AD4600A0CC5C89F1'H   callReferenceValue 235   disengageReason normalDrop :NULL   callIdentifier   {     guid '0B01EF01BD95D611AD4600A0CC5C89F1'H   }   answeredCall TRUE } </pre> |

Table D-6 Log Listings (continued)

|     |                                                                                                                                                                                                                                                                                                                                                                                                                                                                                               |
|-----|-----------------------------------------------------------------------------------------------------------------------------------------------------------------------------------------------------------------------------------------------------------------------------------------------------------------------------------------------------------------------------------------------------------------------------------------------------------------------------------------------|
| 32. | <pre> value RasMessage ::= disengageConfirm : {   requestSeqNum 28040 } </pre>                                                                                                                                                                                                                                                                                                                                                                                                                |
| 33. | <pre> value RasMessage ::= registrationRequest : {   requestSeqNum 28041   protocolIdentifier { 0 0 8 2250 0 2 }   discoveryComplete FALSE   callSignalAddress   {   }   rasAddress   {     ipAddress :     {       ip 'COA80363'H       port 49450     }   }   terminalType   {     mc FALSE     undefinedNode FALSE   }   gatekeeperIdentifier {"zonetwo"}   endpointVendor   {     vendor     {       t35CountryCode 181       t35Extension 0       manufacturerCode 18     }   } } </pre> |



## Recommended Cisco ATA Tone Parameter Values by Country

---

This section provides tables of recommended tone parameters for the following countries, listed alphabetically:



**Note**

---

The extended tone format used by some countries is available only with Cisco ATA software version 3.0 or later. For more information about tone parameter syntax and formats, see the “Tone Configuration Parameters” section on page 5-41.

---



**Note**

---

The *SIT*Tone parameter applies only to the SIP protocol.

---

- Argentina
- Australia
- Austria
- Belgium
- Brazil
- Canada
- China
- Columbia
- Czech Republic
- Denmark
- Egypt
- Finland
- France
- Germany
- Greece
- Hong Kong
- Hungary
- Iceland

- India
- Indonesia
- Ireland
- Israel
- Italy
- Japan
- Korea
- Luxembourg
- Malaysia
- Mexico
- Netherlands
- New Zealand
- Norway
- Pakistan
- Panama
- Peru
- Philippines
- Poland
- Portugal
- Russia
- Saudi Arabia
- Singapore
- Slovakia
- Slovenia
- South Africa
- Spain
- Sweden
- Switzerland
- Taiwan
- Thailand
- Turkey
- United Kingdom
- United States
- Venezuela

**Table E-1 Argentina**

| <b>Parameter</b> | <b>Recommended Values</b>       |
|------------------|---------------------------------|
| DialTone         | 1,30958,0,3125,0,1,0,0,0        |
| BusyTone         | 1,30958,0,1757,0,0,2400,1600,0  |
| ReorderTone      | 1,30958,0,1757,0,0,2400,3200,0  |
| RingbackTone     | 1,30958,0,1971,0,0,8000,32000,0 |
| SITtone          | 1,30958,0,1757,0,0,2400,1600,0  |

**Table E-2 Australia**

| <b>Parameter</b> | <b>Recommended Values</b>                          |
|------------------|----------------------------------------------------|
| DialTone         | 2,31163,30958,1477,1566,1,0,0,0                    |
| BusyTone         | 1,30958,0,2212,0,0,3000,3000,0                     |
| ReorderTone      | 1,31163,0,2086,0,0,3000,3000,0                     |
| RingbackTone     | 102,31163,1477,30742,1654,2,3200,1600,3200,16000,0 |
| SITtone          | 1,30958,0,2212,0,0,20000,4000,0                    |

**Table E-3 Austria**

| <b>Parameter</b> | <b>Recommended Values</b>                                           |
|------------------|---------------------------------------------------------------------|
| DialTone         | 1,31000,0,3089,0,1,0,0,0                                            |
| BusyTone         | 1,31000,0,1737,0,0,3200,3200,0                                      |
| ReorderTone      | 1,31000,0,1737,0,0,1600,1600,0                                      |
| RingbackTone     | 1,31000,0,1949,0,0,8000,40000,0                                     |
| SITtone          | 101,3,24062,3640,14876,4778,5126,5297,3,2664,0,2664,0,2664,8000,0,0 |

**Table E-4 Belgium**

| <b>Parameter</b> | <b>Recommended Values</b>       |
|------------------|---------------------------------|
| DialTone         | 1,30958,0,4952,0,1,0,0,0        |
| BusyTone         | 1,30958,0,1757,0,0,4000,4000,0  |
| ReorderTone      | 1,30958,0,1757,0,0,1336,1336,0  |
| RingbackTone     | 1,30958,0,1971,0,0,8000,24000,0 |
| SITtone          | 1,30958,0,1757,0,0,1336,1336,0  |

**Table E-5 Brazil**

| Parameter    | Recommended Values                                   |
|--------------|------------------------------------------------------|
| DialTone     | 1,30958,0,3125,0,1,0,0,0                             |
| BusyTone     | 1,30958,0,1757,0,0,2000,2000,0                       |
| ReorderTone  | 1,30958,0,1757,0,0,2000,2000,0                       |
| RingbackTone | 1,30958,0,1971,0,0,8000,32000,0                      |
| SITtone      | 100,1,30958,1757,0,0,0,2,6000,2000,2000,2000,0,0,0,0 |

**Table E-6 Canada**

| Parameter    | Recommended Values                    |
|--------------|---------------------------------------|
| DialTone     | 2,31537,30830,1490,1859,1,0,0,0       |
| BusyTone     | 2,30466,28958,1246,1583,0,4000,4000,0 |
| ReorderTone  | 2,30466,28958,1246,1583,0,2000,2000,0 |
| RingbackTone | 2,30830,30466,793,862,0,8000,24000,0  |
| SITtone      | 2,30466,28958,1246,1583,0,2000,2000,0 |

**Table E-7 China**

| Parameter    | Recommended Values                                 |
|--------------|----------------------------------------------------|
| DialTone     | 1,30742,0,5870,0,1,0,0,0                           |
| BusyTone     | 1,30742,0,5870,0,0,2800,2800,0                     |
| ReorderTone  | 1,30742,0,5870,0,0,5600,5600,0                     |
| RingbackTone | 1,30742,0,5870,0,0,8000,32000,0                    |
| SITtone      | 100,1,30742,1856,0,0,0,2,800,800,3200,3200,0,0,2,0 |

**Table E-8 Columbia**

| Parameter    | Recommended Values              |
|--------------|---------------------------------|
| DialTone     | 1,30958,0,3125,0,1,0,0,0        |
| BusyTone     | 1,30958,0,1757,0,0,2000,2000,0  |
| ReorderTone  | 1,30958,0,1757,0,0,2000,2000,0  |
| RingbackTone | 1,30958,0,1971,0,0,8000,32000,0 |
| SITtone      | 1,30958,0,1757,0,0,2000,2000,0  |

**Table E-9 Czech Republic**

| <b>Parameter</b> | <b>Recommended Values</b>       |
|------------------|---------------------------------|
| DialTone         | 1,30958,0,3125,0,1,0,0,0        |
| BusyTone         | 1,30958,0,1757,0,0,2664,2664,0  |
| ReorderTone      | 1,30958,0,1757,0,0,1336,1336,0  |
| RingbackTone     | 1,30958,0,1971,0,0,8000,32000,0 |
| SITtone          | 1,30958,0,1757,0,0,1336,1336,0  |

**Table E-10 Denmark**

| <b>Parameter</b> | <b>Recommended Values</b>                                           |
|------------------|---------------------------------------------------------------------|
| DialTone         | 1,30958,0,3125,0,1,0,0,0                                            |
| BusyTone         | 1,30958,0,1757,0,0,2000,2000,0                                      |
| ReorderTone      | 1,30958,0,1757,0,0,2000,2000,0                                      |
| RingbackTone     | 1,30958,0,1757,0,0,8000,32000,0                                     |
| SITtone          | 101,3,24062,3640,14876,4778,5126,5297,3,2664,0,2664,0,2664,8000,0,0 |

**Table E-11 Egypt**

| <b>Parameter</b> | <b>Recommended Values</b>              |
|------------------|----------------------------------------|
| DialTone         | 1,30958,0,3125,0,1,0,0,0               |
| BusyTone         | 2,31356,30513,1102,1384,0,8000,32000,0 |
| ReorderTone      | 1,30742,0,1856,0,0,4000,4000,0         |
| RingbackTone     | 2,31356,31356,1237,1237,0,16000,8000,0 |
| SITtone          | 1,30742,0,1856,0,0,4000,4000,0         |

**Table E-12 Finland**

| <b>Parameter</b> | <b>Recommended Values</b>       |
|------------------|---------------------------------|
| DialTone         | 1,30958,0,4952,0,1,0,0,0        |
| BusyTone         | 1,30958,0,4952,0,0,2400,2400,0  |
| ReorderTone      | 1,30958,0,5556,0,0,1600,2000,0  |
| RingbackTone     | 1,30958,0,9545,0,0,8000,32000,0 |
| SITtone          | 1,30958,0,1757,0,0,1600,1600,0  |

**Table E-13 France**

| <b>Parameter</b> | <b>Recommended Values</b>        |
|------------------|----------------------------------|
| DialTone         | 1,30830,0,3231,0,1,0,0,0         |
| BusyTone         | 1,30830,0,1817,0,0,4000,4000,0   |
| ReorderTone      | 1,30830,0,1817,0,0,4000,4000,0   |
| RingbackTone     | 1,30830,0,2038,0,0,12000,28000,0 |
| SITtone          | 1,30830,0,1817,0,0,4000,4000,0   |

**Table E-14 Germany**

| <b>Parameter</b> | <b>Recommended Values</b>       |
|------------------|---------------------------------|
| DialTone         | 1,30958,0,3125,0,1,0,0,0        |
| BusyTone         | 1,30958,0,1757,0,0,3840,3840,0  |
| ReorderTone      | 1,30958,0,1757,0,0,1920,1920,0  |
| RingbackTone     | 1,30958,0,1971,0,0,8000,32000,0 |
| SITtone          | 1,30958,0,1757,0,0,1920,1920,0  |

**Table E-15 Greece**

| <b>Parameter</b> | <b>Recommended Values</b>                  |
|------------------|--------------------------------------------|
| DialTone         | 101,30958,3587,0,0,2,1600,2400,5600,6400,0 |
| BusyTone         | 1,30958,0,1757,0,0,2400,2400,0             |
| ReorderTone      | 1,30958,0,1757,0,0,2400,2400,0             |
| RingbackTone     | 1,30958,0,3426,0,0,8000,32000,0            |
| SITtone          | 1,30958,0,1757,0,0,2400,2400,0             |

**Table E-16 Hong Kong**

| <b>Parameter</b> | <b>Recommended Values</b>                          |
|------------------|----------------------------------------------------|
| DialTone         | 2,31537,30830,1833,2287,1,0,0,0                    |
| BusyTone         | 2,30466,28958,2215,2816,0,4000,4000,0              |
| ReorderTone      | 2,30466,28958,2215,2816,0,2000,2000,0              |
| RingbackTone     | 102,30830,2038,30466,2215,2,3200,1600,3200,24000,0 |
| SITtone          | 2,30466,28958,1398,1777,1,0,0,0                    |



**Table E-17 Hungary**

| <b>Parameter</b> | <b>Recommended Values</b>       |
|------------------|---------------------------------|
| DialTone         | 1,30958,0,3197,0,1,0,0,0        |
| BusyTone         | 1,30958,0,1737,0,0,2400,2400,0  |
| ReorderTone      | 1,30958,0,1737,0,0,2400,2400,0  |
| RingbackTone     | 1,30958,0,1927,0,0,9600,29600,0 |
| SITtone          | 1,30958,0,1737,0,0,2400,2400,0  |

**Table E-18 Iceland**

| <b>Parameter</b> | <b>Recommended Values</b>       |
|------------------|---------------------------------|
| DialTone         | 1,30958,0,3125,0,1,0,0,0        |
| BusyTone         | 1,30958,0,1757,0,0,2000,2000,0  |
| ReorderTone      | 1,30958,0,1757,0,0,2000,2000,0  |
| RingbackTone     | 1,30958,0,1971,0,0,9600,37600,0 |
| SITtone          | 1,30958,0,1757,0,0,2000,2000,0  |

**Table E-19 India**

| <b>Parameter</b> | <b>Recommended Values</b>                          |
|------------------|----------------------------------------------------|
| DialTone         | 2,31356,30958,5336,6023,1,0,0,0                    |
| BusyTone         | 1,31163,0,9003,0,0,6000,6000,0                     |
| ReorderTone      | 1,31163,0,1657,0,0,2000,4000,0                     |
| RingbackTone     | 102,31356,3485,30958,3934,2,3200,1600,3200,16000,0 |
| SITtone          | 1,31163,0,1657,0,0,20000,4000,0                    |

**Table E-20 Indonesia**

| <b>Parameter</b> | <b>Recommended Values</b>       |
|------------------|---------------------------------|
| DialTone         | 1,30958,0,3125,0,1,0,0,0        |
| BusyTone         | 1,30958,0,1757,0,0,4000,4000,0  |
| ReorderTone      | 1,30958,0,1757,0,0,2000,2000,0  |
| RingbackTone     | 1,30958,0,1971,0,0,8000,32000,0 |
| SITtone          | 1,30958,0,1757,0,0,20000,4000,0 |

**Table E-21 Ireland**

| <b>Parameter</b> | <b>Recommended Values</b>                          |
|------------------|----------------------------------------------------|
| DialTone         | 1,30958,0,7582,0,1,0,0,0                           |
| BusyTone         | 1,30958,0,6758,0,0,4000,4000,0                     |
| ReorderTone      | 1,30958,0,1757,0,0,48000,8000,0                    |
| RingbackTone     | 102,31163,3194,30742,3578,2,3200,1600,3200,16000,0 |
| SITtone          | 1,30958,0,1757,0,0,48000,8000,0                    |

**Table E-22 Israel**

| <b>Parameter</b> | <b>Recommended Values</b>                                           |
|------------------|---------------------------------------------------------------------|
| DialTone         | 1,30958,0,3125,0,1,0,0,0                                            |
| BusyTone         | 1,30958,0,1757,0,0,4000,4000,0                                      |
| ReorderTone      | 1,30958,0,1757,0,0,2000,2000,0                                      |
| RingbackTone     | 1,31163,0,1859,0,0,8000,24000,0                                     |
| SITtone          | 101,3,23620,3717,14876,4778,5126,5297,3,2664,0,2664,0,2664,8000,0,0 |

**Table E-23 Italy**

| <b>Parameter</b> | <b>Recommended Values</b>                  |
|------------------|--------------------------------------------|
| DialTone         | 101,30958,3125,0,0,2,1600,1600,4800,8000,0 |
| BusyTone         | 1,30958,0,1757,0,0,4000,4000,0             |
| ReorderTone      | 1,30958,0,1757,0,0,1600,1600,0             |
| RingbackTone     | 1,30958,0,1971,0,0,8000,32000,0            |
| SITtone          | 1,30958,0,1757,0,0,4000,4000,0             |

**Table E-24 Japan**

| <b>Parameter</b> | <b>Recommended Values</b>              |
|------------------|----------------------------------------|
| DialTone         | 1,31163,0,1657,0,1,0,0,0               |
| BusyTone         | 1,31163,0,1859,0,0,4000,4000,0         |
| ReorderTone      | 1,31163,0,1859,0,0,4000,4000,0         |
| RingbackTone     | 2,31318,31000,1769,1949,0,8000,16000,0 |
| SITtone          | 1,31163,0,1859,0,0,4000,4000,0         |

**Table E-25 Korea**

| <b>Parameter</b> | <b>Recommended Values</b>                              |
|------------------|--------------------------------------------------------|
| DialTone         | 2,31537,30830,1833,2287,1,0,0,0                        |
| BusyTone         | 2,30466,28958,1398,1777,0,4000,4000,0                  |
| ReorderTone      | 2,30466,28958,1398,1777,0,2400,1600,0                  |
| RingbackTone     | 2,30830,30466,1443,1568,0,8000,16000,0                 |
| SITtone          | 100,1,30742,1856,0,0,0,0,2,1600,800,1600,12000,0,0,0,0 |

**Table E-26 Luxembourg**

| <b>Parameter</b> | <b>Recommended Values</b>       |
|------------------|---------------------------------|
| DialTone         | 1,30958,0,3125,0,1,0,0,0        |
| BusyTone         | 1,30958,0,1757,0,0,4000,4000,0  |
| ReorderTone      | 1,30958,0,1757,0,0,2000,2000,0  |
| RingbackTone     | 1,30958,0,1971,0,0,8000,32000,0 |
| SITtone          | 1,30958,0,1757,0,0,2000,2000,0  |

**Table E-27 Malaysia**

| <b>Parameter</b> | <b>Recommended Values</b>                   |
|------------------|---------------------------------------------|
| DialTone         | 1,30958,0,3125,0,1,0,0,0                    |
| BusyTone         | 1,30958,0,1757,0,0,3840,3840,0              |
| ReorderTone      | 1,30958,0,1757,0,0,2000,2000,0              |
| RingbackTone     | 101,30958,1971,0,0,2,3200,1600,3200,16000,0 |
| SITtone          | 1,30958,0,1757,0,0,20000,4000,0             |

**Table E-28 Mexico**

| <b>Parameter</b> | <b>Recommended Values</b>       |
|------------------|---------------------------------|
| DialTone         | 1,30958,0,3125,0,1,0,0,0        |
| BusyTone         | 1,30958,0,1757,0,0,2000,2000,0  |
| ReorderTone      | 1,30958,0,1757,0,0,2000,2000,0  |
| RingbackTone     | 1,30958,0,1971,0,0,8000,32000,0 |
| SITtone          | 1,30958,0,1757,0,0,2000,2000,0  |

**Table E-29 Netherlands**

| <b>Parameter</b> | <b>Recommended Values</b>       |
|------------------|---------------------------------|
| DialTone         | 1,30958,0,3125,0,1,0,0,0        |
| BusyTone         | 1,30958,0,1757,0,0,4000,4000,0  |
| ReorderTone      | 1,30958,0,1757,0,0,2000,2000,0  |
| RingbackTone     | 1,30958,0,4839,0,0,8000,32000,0 |
| SITtone          | 1,30958,0,1757,0,0,2000,2000,0  |

**Table E-30 New Zealand**

| <b>Parameter</b> | <b>Recommended Values</b>                           |
|------------------|-----------------------------------------------------|
| DialTone         | 1,31163,0,3307,0,1,0,0,0                            |
| BusyTone         | 1,31163,0,1657,0,0,4000,4000,0                      |
| ReorderTone      | 1,24916,0,3483,0,0,4000,4000,0                      |
| RingbackTone     | 102,31163,1316,30742,1474,2,3200,1600,3200,16000,0  |
| SITtone          | 100,1,31163,1657,0,0,0,2,6000,800,6000,3200,0,0,2,0 |

**Table E-31 Norway**

| <b>Parameter</b> | <b>Recommended Values</b>       |
|------------------|---------------------------------|
| DialTone         | 1,30958,0,3125,0,1,0,0,0        |
| BusyTone         | 1,30958,0,1757,0,0,4000,4000,0  |
| ReorderTone      | 1,30958,0,1757,0,0,2000,2000,0  |
| RingbackTone     | 1,30958,0,3053,0,0,8000,32000,0 |
| SITtone          | 1,30958,0,1757,0,0,2000,2000,0  |

**Table E-32 Pakistan**

| <b>Parameter</b> | <b>Recommended Values</b>       |
|------------------|---------------------------------|
| DialTone         | 1,31163,0,2947,0,1,0,0,0        |
| BusyTone         | 1,31163,0,1657,0,0,6000,6000,0  |
| ReorderTone      | 1,31163,0,1657,0,0,6000,6000,0  |
| RingbackTone     | 1,30742,0,2083,0,0,8000,32000,0 |
| SITtone          | 1,31163,0,1657,0,0,6000,6000,0  |

**Table E-33 Panama**

| <b>Parameter</b> | <b>Recommended Values</b>                              |
|------------------|--------------------------------------------------------|
| DialTone         | 1,30958,0,3125,0,1,0,0,0                               |
| BusyTone         | 1,30958,0,1757,0,0,2560,37200,0                        |
| ReorderTone      | 1,30958,0,1757,0,0,2560,37200,0                        |
| RingbackTone     | 1,30958,0,1971,0,0,8000,37200,0                        |
| SITtone          | 100,1,30958,3125,0,0,0,0,2,1440,1440,4000,1440,0,0,0,0 |

**Table E-34 Peru**

| <b>Parameter</b> | <b>Recommended Values</b>       |
|------------------|---------------------------------|
| DialTone         | 1,30958,0,3125,0,1,0,0,0        |
| BusyTone         | 1,30958,0,1757,0,0,2000,2000,0  |
| ReorderTone      | 1,30958,0,1757,0,0,2000,2000,0  |
| RingbackTone     | 1,30958,0,1971,0,0,8000,32000,0 |
| SITtone          | 1,30958,0,1757,0,0,2000,2000,0  |

**Table E-35 Phillipines**

| <b>Parameter</b> | <b>Recommended Values</b>             |
|------------------|---------------------------------------|
| DialTone         | 1,30958,0,3125,0,1,0,0,0              |
| BusyTone         | 1,30958,0,1757,0,0,4000,4000,0        |
| ReorderTone      | 2,30466,28958,1398,1777,0,2000,2000,0 |
| RingbackTone     | 1,30742,0,2083,0,0,8000,32000,0       |
| SITtone          | 2,30466,27666,1398,2034,0,2000,2000,0 |

**Table E-36 Poland**

| <b>Parameter</b> | <b>Recommended Values</b>       |
|------------------|---------------------------------|
| DialTone         | 1,30958,0,3889,0,1,0,0,0        |
| BusyTone         | 1,30958,0,5368,0,0,4000,4000,0  |
| ReorderTone      | 1,30958,0,1697,0,0,4000,4000,0  |
| RingbackTone     | 1,30742,0,8010,0,0,8000,32000,0 |
| SITtone          | 1,30958,0,1697,0,0,4000,4000,0  |

**Table E-37 Portugal**

| <b>Parameter</b> | <b>Recommended Values</b>       |
|------------------|---------------------------------|
| DialTone         | 1,30958,0,3889,0,1,0,0,0        |
| BusyTone         | 1,30958,0,1757,0,0,4000,4000,0  |
| ReorderTone      | 1,30958,0,1757,0,0,1600,1600,0  |
| RingbackTone     | 1,30742,0,2083,0,0,8000,40000,0 |
| SITtone          | 1,30958,0,1757,0,0,1600,1600,0  |

**Table E-38 Russia**

| <b>Parameter</b> | <b>Recommended Values</b>       |
|------------------|---------------------------------|
| DialTone         | 1,30958,0,3889,0,1,0,0,0        |
| BusyTone         | 1,30958,0,1757,0,0,3200,3200,0  |
| ReorderTone      | 1,30958,0,1757,0,0,1600,1600,0  |
| RingbackTone     | 1,30742,0,2083,0,0,6400,25600,0 |
| SITtone          | 1,30958,0,1757,0,0,1600,1600,0  |

**Table E-39 Saudi Arabia**

| <b>Parameter</b> | <b>Recommended Values</b>       |
|------------------|---------------------------------|
| DialTone         | 1,30958,0,3889,0,1,0,0,0        |
| BusyTone         | 1,30958,0,1757,0,0,4000,4000,0  |
| ReorderTone      | 1,30958,0,1757,0,0,4000,4000,0  |
| RingbackTone     | 1,30958,0,1971,0,0,9600,36800,0 |
| SITtone          | 1,30958,0,1757,0,0,4000,4000,0  |

**Table E-40 Singapore**

| <b>Parameter</b> | <b>Recommended Values</b>                          |
|------------------|----------------------------------------------------|
| DialTone         | 1,30958,0,3506,0,1,0,0,0                           |
| BusyTone         | 1,30958,0,1757,0,0,6000,6000,0                     |
| ReorderTone      | 1,30958,0,1757,0,0,2000,2000,0                     |
| RingbackTone     | 102,31163,3710,30742,4156,2,3200,1600,3200,16000,0 |
| SITtone          | 1,30958,0,1757,0,0,20000,4000,0                    |

**Table E-41 Slovakia**

| Parameter    | Recommended Values              |
|--------------|---------------------------------|
| DialTone     | 1,30958,0,3889,0,1,0,0,0        |
| BusyTone     | 1,30958,0,1757,0,0,2640,2640,0  |
| ReorderTone  | 1,30958,0,1757,0,0,1320,1320,0  |
| RingbackTone | 1,30958,0,1971,0,0,8000,32000,0 |
| SITtone      | 1,30958,0,1757,0,0,1320,1320,0  |

**Table E-42 Slovenia**

| Parameter    | Recommended Values                         |
|--------------|--------------------------------------------|
| DialTone     | 101,30958,3125,0,0,2,1600,2400,5600,6400,0 |
| BusyTone     | 1,30958,0,1757,0,0,4000,4000,0             |
| ReorderTone  | 1,30958,0,1757,0,0,1600,1600,0             |
| RingbackTone | 1,30958,0,1971,0,0,8000,32000,0            |
| SITtone      | 1,30958,0,1757,0,0,1600,1600,0             |

**Table E-43 South Africa**

| Parameter    | Recommended Values                                 |
|--------------|----------------------------------------------------|
| DialTone     | 2,31415,30890,1919,2252,1,0,0,0                    |
| BusyTone     | 1,31163,0,1657,0,0,4000,4000,0                     |
| ReorderTone  | 1,31163,0,1657,0,0,2000,2000,0                     |
| RingbackTone | 102,31415,1079,30890,1266,2,3200,1600,3200,16000,0 |
| SITtone      | 1,31163,0,1657,0,0,20000,4000,0                    |

**Table E-44 Spain**

| Parameter    | Recommended Values                                   |
|--------------|------------------------------------------------------|
| DialTone     | 1,30958,0,4895,0,1,0,0,0                             |
| BusyTone     | 1,30958,0,1757,0,0,1600,1600,0                       |
| ReorderTone  | 100,1,30958,1757,0,0,0,2,1600,1600,1600,4800,0,0,1,0 |
| RingbackTone | 1,30958,0,1757,0,0,12000,24000,0                     |
| SITtone      | 100,1,30958,1757,0,0,0,2,1600,1600,1600,4800,0,0,0,0 |

**Table E-45 Sweden**

| <b>Parameter</b> | <b>Recommended Values</b>                                           |
|------------------|---------------------------------------------------------------------|
| DialTone         | 1,30958,0,3889,0,1,0,0,0                                            |
| BusyTone         | 1,30958,0,1757,0,0,2000,2000,0                                      |
| ReorderTone      | 1,30958,0,1757,0,0,2000,6000,0                                      |
| RingbackTone     | 1,30958,0,1927,0,0,8000,40000,0                                     |
| SITtone          | 101,3,24062,3640,14876,4778,5126,5297,3,2664,0,2664,0,2664,8000,0,0 |
| CallWaitTone     | 1,30958,0,1757,0,0,1600,4000,11200                                  |
| AlertTone        | 1,30467,0,4385,0,0,480,480,1920                                     |

**Table E-46 Switzerland**

| <b>Parameter</b> | <b>Recommended Values</b>       |
|------------------|---------------------------------|
| DialTone         | 1,30958,0,3506,0,1,0,0,0        |
| BusyTone         | 1,30958,0,1757,0,0,4000,4000,0  |
| ReorderTone      | 1,30958,0,1757,0,0,1600,1600,0  |
| RingbackTone     | 1,30958,0,1927,0,0,8000,32000,0 |
| SITtone          | 1,30958,0,1757,0,0,1600,1600,0  |

**Table E-47 Taiwan**

| <b>Parameter</b> | <b>Recommended Values</b>                          |
|------------------|----------------------------------------------------|
| DialTone         | 2,31537,30830,1833,2287,1,0,0,0                    |
| BusyTone         | 2,30466,28958,1398,1777,0,4000,4000,0              |
| ReorderTone      | 2,30466,28958,1398,1777,0,2000,2000,0              |
| RingbackTone     | 102,30830,1443,30466,1568,2,3200,1600,3200,16000,0 |
| SITtone          | 2,30466,28958,1398,1777,0,2000,2000,0              |

**Table E-48 Thailand**

| <b>Parameter</b> | <b>Recommended Values</b>                           |
|------------------|-----------------------------------------------------|
| DialTone         | 1,31163,0,2947,0,1,0,0,0                            |
| BusyTone         | 1,31163,0,1657,0,0,4000,4000,0                      |
| ReorderTone      | 1,30742,0,1856,0,0,2640,2640,0                      |
| RingbackTone     | 1,31163,0,1657,0,0,8000,32000,0                     |
| SITtone          | 100,1,31163,1657,0,0,0,2,800,7200,2400,5600,0,0,5,0 |



**Table E-49 Turkey**

| Parameter    | Recommended Values                                   |
|--------------|------------------------------------------------------|
| DialTone     | 1,30742,0,3301,0,1,0,0,0                             |
| BusyTone     | 1,30742,0,1856,0,0,4000,4000,0                       |
| ReorderTone  | 100,1,30742,1856,0,0,0,2,1600,1600,4800,1600,0,0,2,0 |
| RingbackTone | 1,30742,0,2083,0,0,16000,32000,0                     |
| SITtone      | 1,30742,0,1856,0,0,1600,1600,0                       |

**Table E-50 United Kingdom**

| Parameter    | Recommended Values                                   |
|--------------|------------------------------------------------------|
| DialTone     | 2,31537,30830,1833,2287,1,0,0,0                      |
| BusyTone     | 1,31163,0,1657,0,0,3000,3000,0                       |
| ReorderTone  | 100,1,31163,1657,0,0,0,2,3200,2800,1800,4200,0,0,0,0 |
| RingbackTone | 102,31163,1173,30742,1314,2,3200,1600,3200,16000,0   |
| SITtone      | 1,31163,0,2947,0,1,0,0,0                             |

**Table E-51 United States**

| Parameter    | Recommended Values                    |
|--------------|---------------------------------------|
| DialTone     | 2,31537,30830,1490,1859,1,0,0,0       |
| BusyTone     | 2,30466,28958,1246,1583,0,4000,4000,0 |
| ReorderTone  | 2,30466,28958,1246,1583,0,2000,2000,0 |
| RingbackTone | 2,30830,30466,793,862,0,8000,24000,0  |
| SITtone      | 2,30466,28958,1246,1583,0,2000,2000,0 |

**Table E-52 Venezuela**

| Parameter    | Recommended Values              |
|--------------|---------------------------------|
| DialTone     | 1,30958,0,3506,0,1,0,0,0        |
| BusyTone     | 1,30958,0,1757,0,0,2000,2000,0  |
| ReorderTone  | 1,30958,0,1757,0,0,2000,2000,0  |
| RingbackTone | 1,30958,0,1757,0,0,8000,32000,0 |
| SITtone      | 1,30958,0,1757,0,0,2000,2000,0  |





## GLOSSARY

---

### Numerics

**10BaseT** 10-Mbps baseband Ethernet specification using two pairs of twisted-pair cabling (Categories 3, 4, or 5): one pair for transmitting data and the other for receiving data. 10BASET, which is part of the IEEE 802.3 specification, has a distance limit of approximately 328 feet (100 meters) per segment.

---

### A

**A-law** ITU-T companding standard used in the conversion between analog and digital signals in PCM systems. A-law is used primarily in European telephone networks and is similar to the North American  $\mu$ -law standard. See also companding and  $\mu$ -law.

**AVT tones** Out-of-bound signaling as defined in RFC 2833.

---

### C

**category-3 cable** One of five grades of UTP cabling described in the EIA/TIA-586 standard. Category 3 cabling is used in 10BaseT networks and can transmit data at speeds up to 10 Mbps.

**CED tone detection** Called station identification. A three-second, 2100 Hz tone generated by a fax machine answering a call, which is used in the hand-shaking used to set the call; the response from a called fax machine to a CNG tone.

**CELP** code excited linear prediction compression. Compression algorithm used in low bit-rate voice encoding. Used in ITU-T Recommendations G.728, G.729, G.723.1.

**CLIP** Calling Line Identification Presentation. Shows your identity to callers with Caller ID.

**CLIR** Calling Line Identification Restriction. Hides your identity from callers with Caller ID.

**CNG** Comfort Noise Generation.

**codec** coder decoder. In Voice over IP, Voice over Frame Relay, and Voice over ATM, a DSP software algorithm used to compress/decompress speech or audio signals.

**companding** Contraction derived from the opposite processes of compression and expansion. Part of the PCM process whereby analog signal values are rounded logically to discrete scale-step values on a nonlinear scale. The decimal step number then is coded in its binary equivalent prior to transmission. The process is reversed at the receiving terminal using the same nonlinear scale. Compare with compression and expansion. See also a-law and  $\mu$ -law.

|                    |                                                                                                                                                                                                                                                                                                                                           |
|--------------------|-------------------------------------------------------------------------------------------------------------------------------------------------------------------------------------------------------------------------------------------------------------------------------------------------------------------------------------------|
| <b>compression</b> | The running of a data set through an algorithm that reduces the space required to store or the bandwidth required to transmit the data set. Compare with companding and expansion.                                                                                                                                                        |
| <b>CoS</b>         | Class of service. An indication of how an upper-layer protocol requires a lower-layer protocol to treat its messages. In SNA subarea routing, CoS definitions are used by subarea nodes to determine the optimal route to establish a given session. A CoS definition comprises a virtual route number and a transmission priority field. |

---

**D**

|                  |                                                                                                                                                                   |
|------------------|-------------------------------------------------------------------------------------------------------------------------------------------------------------------|
| <b>DHCP</b>      | Dynamic Host Configuration Protocol. Provides a mechanism for allocating IP addresses dynamically so that addresses can be reused when hosts no longer need them. |
| <b>dial peer</b> | An addressable call endpoint. In Voice over IP (VoIP), there are two types of dial peers: POTS and VoIP.                                                          |
| <b>DNS</b>       | Domain Name System. System used on the Internet for translating names of network nodes into addresses.                                                            |
| <b>DSP</b>       | digital signal processor. A DSP segments the voice signal into frames and stores them in voice packets.                                                           |
| <b>DTMF</b>      | dual tone multifrequency. Tones generated when a button is pressed on a telephone, primarily used in the U.S. and Canada.                                         |

---

**E**

|                  |                                                                                                                                                             |
|------------------|-------------------------------------------------------------------------------------------------------------------------------------------------------------|
| <b>E.164</b>     | The international public telecommunications numbering plan. A standard set by the ITU-T which addresses telephone numbers.                                  |
| <b>endpoint</b>  | A SIP terminal or gateway. An endpoint can call and be called. It generates and/or terminates the information stream.                                       |
| <b>expansion</b> | The process of running a compressed data set through an algorithm that restores the data set to its original size. Compare with companding and compression. |

---

**F**

|                 |                                                                                                                                                                                                                                                         |
|-----------------|---------------------------------------------------------------------------------------------------------------------------------------------------------------------------------------------------------------------------------------------------------|
| <b>firewall</b> | Router or access server, or several routers or access servers, designated as a buffer between any connected public networks and a private network. A firewall router uses access lists and other methods to ensure the security of the private network. |
| <b>FoIP</b>     | Fax over IP                                                                                                                                                                                                                                             |
| <b>FQDN</b>     | Fully Qualified Domain (FQDN) format “mydomain.com” or “company.mydomain.com.”                                                                                                                                                                          |
| <b>FSK</b>      | Frequency shift key.                                                                                                                                                                                                                                    |

- FXO** Foreign Exchange Office. An FXO interface connects to the public switched telephone network (PSTN) central office and is the interface offered on a standard telephone. Cisco FXO interface is an RJ-11 connector that allows an analog connection at the PSTN central office or to a station interface on a PBX.
- FXS** Foreign Exchange Station. An FXS interface connects directly to a standard telephone and supplies ring, voltage, and dial tone. Cisco's FXS interface is an RJ-11 connector that allows connections to basic telephone service equipment, keysets, and PBXs.

---

**G**

- G.711** Describes the 64-kbps PCM voice coding technique. In G.711, encoded voice is already in the correct format for digital voice delivery in the PSTN or through PBXs. Described in the ITU-T standard in its G-series recommendations.
- G.723.1** Describes a compression technique that can be used for compressing speech or audio signal components at a very low bit rate as part of the H.324 family of standards. This Codec has two bit rates associated with it: 5.3 and 6.3 kbps. The higher bit rate is based on ML-MLQ technology and provides a somewhat higher quality of sound. The lower bit rate is based on CELP and provides system designers with additional flexibility. Described in the ITU-T standard in its G-series recommendations.
- G.729A** Describes CELP compression where voice is coded into 8-kbps streams. There are two variations of this standard (G.729 and G.729 Annex A) that differ mainly in computational complexity; both provide speech quality similar to 32-kbps ADPCM. Described in the ITU-T standard in its G-series recommendations.
- gateway** A gateway allows SIP or H.323 terminals to communicate with terminals configured to other protocols by converting protocols. A gateway is the point where a circuit-switched call is encoded and repackaged into IP packets.

---

**H**

- H.245** An ITU standard that governs H.245 endpoint control.
- H.323** H.323 allows dissimilar communication devices to communicate with each other by using a standard communication protocol. H.323 defines a common set of CODECs, call setup and negotiating procedures, and basic data transport methods.

---

**I**

- ICMP** Internet Control Message Protocol

**IP** Internet Protocol. Network layer protocol in the TCP/IP stack offering a connectionless internetwork service. IP provides features for addressing, type-of-service specification, fragmentation and reassembly, and security. Defined in RFC 791.

**IVR** Interactive voice response. Term used to describe systems that provide information in the form of recorded messages over telephone lines in response to user input in the form of spoken words or, more commonly, DTMF signaling.

---

## L

**LDAP** Lightweight Directory Access Protocol

**LEC** local exchange carrier.

**Location Server** A SIP redirect or proxy server uses a location server to get information about a caller's location. Location services are offered by location servers.

---

## M

**MGCP** Media Gateway Control Protocol.

**MWI** message waiting indication.

**μ-law** North American companding standard used in conversion between analog and digital signals in PCM systems. Similar to the European a-law. See also a-law and companding.

---

## N

**NAT** Network Address Translation. Mechanism for reducing the need for globally unique IP addresses. NAT allows an organization with addresses that are not globally unique to connect to the Internet by translating those addresses into globally routable address spaces. Also known as Network Address Translator.

**NSE packets** Real-Time Transport Protocol (RTP) digit events are encoded using the Named Signaling Event (NSE) format specified in RFC 2833, Section 3.0.

**NAT Server** Network Address Translation. an Internet standard that enables a local-area network (LAN) to use one set of IP addresses for internal traffic and a second set of addresses for external traffic.

**NTP** Network Time Protocol. Protocol built on top of TCP that assures accurate local time-keeping with reference to radio and atomic clocks located on the Internet. This protocol is capable of synchronizing distributed clocks within milliseconds over long time periods.

---

**P**

- POTS** Plain old telephone service. Basic telephone service supplying standard single-line telephones, telephone lines, and access to the PSTN.
- Proxy Server** An intermediary program that acts as both a server and a client for the purpose of making requests on behalf of other clients. Requests are serviced internally or by passing them on, possibly after translation, to other servers. A proxy interprets, and, if necessary, rewrites a request message before forwarding it.
- PSTN** Public switched telephone network.

---

**Q**

- QoS** Quality of Service. The capability of a network to provide better service to selected network traffic over various technologies, including Frame Relay, Asynchronous Transfer Mode (ATM), Ethernet and 802.1 networks, SONET, and IP-routed networks that may use any or all of these underlying technologies. The primary goal of QoS is to provide priority including dedicated bandwidth, controlled jitter and latency (required by some real-time and interactive traffic), and improved loss characteristics.

---

**R**

- Redirect Server** A redirect server is a server that accepts a SIP request, maps the address into zero or more new addresses, and returns these addresses to the client. It does not initiate its own SIP request nor accept calls.
- Registrar Server** A registrar server is a server that accepts Register requests. A registrar is typically co-located with a proxy or redirect server and may offer location services.
- router** Network layer device that uses one or more metrics to determine the optimal path along which network traffic should be forwarded. Routers forward packets from one network to another based on network layer information. Occasionally called a gateway (although this definition of gateway is becoming increasingly outdated). Compare with gateway.
- RTP** Real-Time Transport Protocol. One of the IPv6 protocols. RTP is designed to provide end-to-end network transport functions for applications transmitting real-time data, such as audio, video, or simulation data, over multicast or unicast network services. RTP provides services such as payload type identification, sequence numbering, timestamping, and delivery monitoring to real-time applications.

---

**S**

- SCCP** Signaling connection control part.
- SDP** Session Definition Protocol. An IETF protocol for the definition of Multimedia Services. SDP messages can be part of SGCP and MGCP messages.

|                     |                                                                                                                                                                                                                                                                               |
|---------------------|-------------------------------------------------------------------------------------------------------------------------------------------------------------------------------------------------------------------------------------------------------------------------------|
| <b>SIP</b>          | Session Initiation Protocol. Protocol developed by the IETF MMUSIC Working Group as an alternative to H.323. SIP features are compliant with IETF RFC 2543, published in March 1999. SIP equips platforms to signal the setup of voice and multimedia calls over IP networks. |
| <b>SIP endpoint</b> | A terminal or gateway that acts as a source or sink of Session Initiation Protocol (SIP) voice data. An endpoint can call or be called, and it generates or terminates the information stream.                                                                                |
| <b>SLIC</b>         | Subscriber Line Interface Circuit. An integrated circuit (IC) providing central office-like telephone interface functionality.                                                                                                                                                |
| <b>SOHO</b>         | Small office, home office. Networking solutions and access technologies for offices that are not directly connected to large corporate networks.                                                                                                                              |

---

**T**

|                         |                                                                                                                                                                                                                                   |
|-------------------------|-----------------------------------------------------------------------------------------------------------------------------------------------------------------------------------------------------------------------------------|
| <b>TCP</b>              | Transmission Control Protocol. Connection-oriented transport layer protocol that provides reliable full-duplex data transmission. TCP is part of the TCP/IP protocol stack.                                                       |
| <b>TFTP</b>             | Trivial File Transfer Protocol. Simplified version of FTP that allows files to be transferred from one computer to another over a network, usually without the use of client authentication (for example, username and password). |
| <b>TN power systems</b> | A TN power system is a power distribution system with one point connected directly to earth (ground). The exposed conductive parts of the installation are connected to that point by protective earth conductors.                |
| <b>TOS</b>              | Type of service. See CoS.                                                                                                                                                                                                         |

---

**U**

|                   |                                                                                                                                                                                                                                                                                                              |
|-------------------|--------------------------------------------------------------------------------------------------------------------------------------------------------------------------------------------------------------------------------------------------------------------------------------------------------------|
| <b>UAC</b>        | User agent client. A client application that initiates the SIP request.                                                                                                                                                                                                                                      |
| <b>UAS</b>        | User agent server (or user agent). A server application that contacts the user when a SIP request is received, and then returns a response on behalf of the user. The response accepts, rejects, or redirects the request.                                                                                   |
| <b>UDP</b>        | User Datagram Protocol. Connectionless transport layer protocol in the TCP/IP protocol stack. UDP is a simple protocol that exchanges datagrams without acknowledgments or guaranteed delivery, requiring that error processing and retransmission be handled by other protocols. UDP is defined in RFC 768. |
| <b>user agent</b> | See UAS.                                                                                                                                                                                                                                                                                                     |

---

**V**

|            |                                                                                                                                                                                                                                                          |
|------------|----------------------------------------------------------------------------------------------------------------------------------------------------------------------------------------------------------------------------------------------------------|
| <b>VAD</b> | Voice activity detection. When enabled on a voice port or a dial peer, silence is not transmitted over the network, only audible speech. When VAD is enabled, the sound quality is slightly degraded but the connection monopolizes much less bandwidth. |
|------------|----------------------------------------------------------------------------------------------------------------------------------------------------------------------------------------------------------------------------------------------------------|



**voice packet gateway**

Gateway platforms that enable Internet telephony service providers to offer residential and business-class services for Internet telephony.

**VoIP**

Voice over IP. The capability to carry normal telephony-style voice over an IP-based Internet with POTS-like functionality, reliability, and voice quality. VoIP enables a router to carry voice traffic (for example, telephone calls and faxes) over an IP network. In VoIP, the DSP segments the voice signal into frames, which then are coupled in groups of two and stored in voice packets. VoIP is a blanket term, which generally refers to Cisco's standard-based (for example H.323) approach to IP voice traffic.

---

**X****XML**

eXtensible Markup Language. Designed to enable the use of SGML on the World-Wide Web. XML allow you to define your own customized markup language.





---

## Numerics

802.1Q VLAN ID 3-4, 5-12

---

### A

Account Information Parameters 5-16

Action Identifiers 6-4

administration-level security 5-20

admission-level security 4-5

alphanumeric values 3-22

alternate H.323 Gatekeeper configuration 4-4

alternate H.323 gatekeeper static configuration 5-14

alternate NTP IP address 5-11

AltGk parameter 5-14

AltNTPIP parameter 5-11

ata.txt file 3-10

atadefault.cfg configuration file 3-17

atadefault.cfg file 3-12

atapname.exe Tool 3-11

ata unique configuration file 3-3, 3-17

audio codecs

- setting 4-7

AudioMode parameter 5-24, 7-2, 7-6

audio packet settings 4-8

authentication

- configuration 4-5
- methods 4-5
- parameters 4-5

authentication ID 5-19

authentication method 4-5, 5-20

---

### B

bearer capability 5-34

Bellcore (FSK) method 5-27

Bellcore method for called ID 5-38

billable features 4-8

binary configuration file creation 3-10

bootload

- process 3-2

boot load behavior 3-2

BusyTone 5-49

---

### C

CallCmd parameter 5-29

Call Command behavior 6-7

call commands 5-29

- changing A-1

caller ID A-2

caller ID configuration 5-29

caller ID format 5-38

CallerIdMethod parameter 5-38

call features 5-27

CallFeatures parameter 5-27

calling line identification presentation (CLIP) A-3

calling line identification restriction

- definition A-4
- in Sweden A-4
- in United States A-4

call-progress toes 5-41

Call-Progress tone parameters 5-41, 5-48

call waiting 4-9

- in Sweden A-3

- in United States **A-3**
- permanent default setting **4-9**
- call-waiting caller ID **A-2**
- call waiting caller ID configuration **5-27, 5-29**
- call waiting configuration **5-27, 5-28**
- call waiting period **5-32**
- call waiting ring timeout **5-30**
- call-waiting tone **5-50**
- CallWaitTone **5-50**
- CDP discovery **5-35**
- cfgfmt.exe tool **3-10, 3-15**
- CFGID **5-63**
- CfgInterval parameter **5-6**
- Cisco ATA-specific configuration file **3-3**
- Cisco Discovery Protocol (CDP) **3-2**
- CLIP **5-27, 5-28**
- codec
  - receiving audio **5-22**
  - transmitting audio **5-22**
- codec negotiation in sending fax **5-33**
- common parameters
  - configuration **3-9**
- conference call
  - in Sweden **A-3**
  - in United States **A-2**
- configurable parameters **4-12**
- configurable reboot of Cisco ATA **4-8**
- configurable reboot time **5-31**
- configurable services **4-12**
- configurable time Ethernet is down before reboot **5-31**
- configuration
  - alternate H.323 Gatekeeper **4-4**
  - atadefault.cfg file **3-12**
  - call-progress tones **5-41**
  - cfgfmt.exe tool **3-10, 3-15**
  - methods
    - using TFTP and DHCP servers **3-8, 3-9**
    - Web-based **3-23, 3-24**
    - Wed-based **3-25**
- parameters **4-12**
  - AltGk **5-14**
  - AltNTPIP **5-11**
  - AudioMode **5-24, 7-2, 7-6**
  - CallCmd **5-29**
  - CallerIdMethod **5-38**
  - CallFeatures **5-27**
  - CfgInterval **5-6**
  - ConnectMode **5-32, 7-3**
  - DHCP **5-8**
  - DialPlan **5-52**
  - DNS1IP **5-11**
  - DNS2IP **5-12**
  - EncryptKey **5-6, 9-13**
  - FeatureTimer **5-30**
  - GkOrProxy **4-2, 5-13**
  - LBRCCodec **5-23**
  - LoginID0 **5-18**
  - LoginID1 **5-19**
  - MediaPort **5-21**
  - network timing **4-11**
  - NPrintF **5-61**
  - NTPIP **5-10**
  - NumTxFrames **5-25**
  - OpFlags **5-34**
  - Polarity **5-39**
  - PWD0 **5-16**
  - PWD1 **5-18**
  - required **4-1**
  - RingOnOffTime **5-51**
  - RxCodec **5-22**
  - SigTimer **5-31**
  - StaticIp **5-9**
  - StaticNetMask **5-10**
  - StaticRoute **5-9**
  - TftpURL **5-5**
  - TimeZone **5-36**
  - ToConfig **5-4**
  - TxCodec **5-22**

- UID0 5-16
- UID1 5-17
- UIPassword 5-3, 9-13
- UseLoginID 5-19
- VLAN Setting 5-12
- tones 5-41
- configuration changes taking effect 3-6
- configuration filename supplied by DHCP server 5-35
- configuration files generated 3-13
- configuration in a non-TFTP server environment 3-7
- configuration in a TFTP server environment 3-5
- configuration update interval 5-6
- congestion tone 5-49
- ConnectMode parameter 5-32, 7-3
- Context-Identifiers 6-3, 6-4
- converting MAC address to hexadecimal format 3-11
- convert unique configuration file to binary format 3-6
- creating a text configuration file 3-9

---

## D

- debugging 9-4
- debugging, preserv.exe program 9-4
- default boot load behavior 3-2
- default configuration file 3-17
- default values 3-9, 5-2
- DHCP enabled 5-8
- DHCP option 150 3-18, 5-35
- DHCP option 66 3-18
- DHCP options 3-19
- DHCP parameter 5-8
- DHCP server
  - configuration without using DHCP 3-20
  - if not under control of Cisco ATA administrator 3-19
- DHCP server usage 3-18
- diagnostics
  - SyslogCtrl 5-62
  - SyslogIP 5-61
  - types of messages to trace 5-62

- diagnostics for debugging 4-10
- dial plan blocking 5-54
- Dial Plan Commands 5-53
- dial plan examples 5-58
- dial plan exceeding 199 characters 5-60
- DialPlanEx parameter 5-60
- DialPlan parameter 4-12, 5-52
- dial plans 4-12, 5-52
- dial plan syntax 5-53
- DialTone 5-48
- disabling CDP discovery 3-4
- disabling use of DHCP server 3-21
- disabling VLAN encapsulation 3-4
- disabling VLAN IP encapsulation 3-3
- DNS1IP parameter 5-11
- DNS2IP parameter 5-12
- downloading Cisco ATA software from CCO 3-7, 3-8
- DTMF method for caller ID 5-38
- DTMF transmission method 4-11, 5-24
- dual-mode registration 4-3
- dynamic alternate Gatekeeper feature 4-4
- dynamic payload type 5-33

---

## E

- E.164 phone numbers 4-5, 5-16, 5-17
- electrical specifications C-2
- enabling user-specified voice VLAN ID 3-4
- EncryptKeyEx parameter 5-7
- encryption 3-12
- encryption examples 3-15
- encryption key 5-6
- EncryptKey parameter 5-6, 9-13
- entering alphanumeric values 3-22
- environmental specifications C-2
- establishing IP connectivity 3-20
- Ethernet ports 1-6
- ETSI 5-38
- example configuration text file 5-2

**F**

factory default reset **3-23**

failback timeout **5-15**

fast-start procedure **5-33**

fax CED tone detection disabling **5-24**

fax mode **7-1, 7-6**

- configuration
  - per-call basis **7-7**
- G.711 codec only setting **5-28**
- no fax tone detection setting **5-28**
- no silence suppression setting **5-28**

fax mode configuration **7-6, 7-7**

fax mode configuration settings **5-28**

fax pass-through **5-33**

fax pass-through codec **5-33**

fax pass-through mode **7-1**

fax pass-through mode, enabling **7-4, 7-5**

fax Pass-through mode configuration **7-2**

fax pass-through NSE payload type **5-33**

fax pass-through redundancy **5-33**

fax relay, disabling **7-5**

fax services **7-1**

fax services, debugging **7-7, 7-9**

FeatureTimer2 parameter **5-31**

FeatureTimer parameter **5-30**

forgotten password **5-4**

frames per packet to transmit **5-25**

frequently asked questions **9-13**

Function button **1-6, 8-1, 9-2**

function button **1-6, 3-3**

FXSInputLevel **5-40**

FXSOutputLevel **5-40**

FXS ports **1-5**

**G**

G.729 resource **4-7**

gatekeeper registration **5-33**

generated configuration files **3-13**

generating binary configuration file **3-10**

GkOrProxy parameter **4-2, 5-13**

Greenwich Mean Time offset **5-36**

**H**

H.225 RAS messages **4-4**

H.245 transmission method **4-12**

H.323

- components **1-3**
- gatekeepers **1-4**
- gateways **1-3**
- hardware **1-5**
- MCUs **1-4**
- overview **1-2**
- proxy server **1-4**
- standard **1-2**
- terminals **1-3**

H.323 connection method **4-12**

H.323 Gatekeeper

- using Cisco ATA without **4-6**
- using multiple Cisco ATAs without **4-6**

H.323 gatekeeper configuration **4-3**

H.323 Gatekeeper registration mode **4-3**

H.323 gateway **4-6**

H.323 gateway parameter **5-20**

h245 tunneling **5-33**

h323\_example.txt file **3-10**

h323\_example.txt sample configuration file **3-9**

h323\_example.txt text file **5-2**

hardware information display **4-10**

hook flash time

- maximum **5-32**
- minimum **5-32**

hook flash timing **4-9**

hookflash transmission method **4-11, 5-24**

Hotline/Warmline **5-54**

HTTP refresh **5-35**

HTTP reset **5-35**

## I

include command **3-10**

input level of FXS ports **5-40**

installation

    procedure **2-3**

IP address of TFTP server **5-5**

IP dial plan configuration **5-60**

IP packets **5-12**

## L

LBRCCodec parameter **5-23**

line polarity **5-39**

local tone playout reporting **9-9**

LoginID0 parameter **5-18**

LoginID1 parameter **5-19**

login ID for Phone 1 port **5-18**

login ID for Phone 2 port **5-19**

low-bit-rate codec **4-7, 5-23, 5-24**

## M

MAC address **3-11**

making configuration changes after boot up **3-11**

maximum number of digits in phone number **5-38**

MediaPort **5-21**

MediaPort parameter **5-21**

mixing of audio and call waiting tone during a call **5-34**

mixing of call waiting tone and audio **4-9**

## N

network parameters **5-8**

network ringback tone **4-10**

network status **9-10, 9-11**

network timing **4-11**

    parameters **4-11**

non-dotted hexadecimal MAC address location **3-10**

NPrintf parameter **5-61**

NSE payload base number **5-33**

NTP IP address **5-10**

NTPIP parameter **5-10**

NumTxFrames parameter **5-25**

## O

obtaining network status **9-10, 9-11**

obtaining non-dotted hexadecimal MAC address of Cisco  
ATA **3-10**

offset from Greenwich Mean Time **4-11**

operate in a Cisco CallManager environment **5-33**

OpFlags parameter **5-34**

output level of FXS ports **5-40**

## P

PaidFeatures **5-28**

paid features **5-28**

parameters

    FeatureTimer2 **5-31**

    required **4-1**

parameters and defaults **xii, 5-1**

parameters for configuration method **5-4**

parameter types **5-1**

password **5-3**

password for Phone 1 port **5-16**

password for Phone 2 port **5-18**

physical interfaces **C-2**

physical specifications **C-1**

Polarity **5-39**

polarity **4-11, 5-39**

Polarity parameter **5-39**

polarity reversal before and after Caller ID signal **5-38**

polarity reversal before and after caller ID signal **5-38**

port for debug messages  
 configuration 5-61  
 powering down 2-5  
 primary domain name server 5-11  
 primary H.323 gatekeeper ID 5-14  
 primary H.323 gatekeeper parameter 5-13  
 priority value 9-5  
 Private Line Automatic Ringdown (PLAR) 5-54  
 progress Indicator 5-33  
 progress tones 4-11  
 prserv 7-9, 7-10  
 PWD0 parameter 5-16  
 PWD1 parameter 5-18

---

## R

RADIUS server 4-5  
 reboot 4-8  
 reboot time configuration 5-31  
 receiving-audio codec 5-22  
 refreshing the Cisco ATA 3-26  
 refresh interval 4-9  
 refresh-interval configuration 3-6, 4-9  
 refresh procedure 3-11  
 registration 5-14  
 registration level-security 4-5  
 registration-level security 5-20  
 registration mode with an H.323 Gatekeeper 4-3  
 reorder delay 5-32  
 Reorder Tone 5-49  
 reorder tone 5-44, 5-49  
 ReorderTone parameter 5-44  
 reorder tone parameter example 5-46, 5-47  
 reporting  
 local tone playout 9-9  
 RTP statistics 9-12  
 request device hostname from the DHCP server  
 configuration 5-36  
 required parameters 4-1

resetting the Cisco ATA 3-26  
 resetting the Cisco ATA to factory defaults 3-23  
 reverse audio cut-through behavior 4-10  
 reviewing default router for Cisco ATA to use 3-22  
 reviewing subnet mask of Cisco ATA 3-22  
 review IP address of Cisco ATA 3-21  
 Ringback Tone 5-50  
 ringer cadence pattern 5-51  
 ring frequency 5-51  
 ringing characteristics C-3  
 ring loads 9-13  
 ring loads and distances 9-13  
 RingOnOffTime 5-51  
 RingOnOffTime parameter 5-51  
 ring timeout 5-32  
 RJ-45 LED  
 Cisco ATA 186 1-6  
 Cisco ATA 188 1-6  
 rtpcatch 7-12, 7-13, 7-14, 7-15, 7-16, 7-18, 7-20  
 RTP frames 7-13  
 RTP media port 5-21  
 RTP packets 7-13  
 RTP payload type 5-33  
 RTP statistics 7-13  
 RTP statistics reporting 9-12  
 RxCodec parameter 5-22

---

## S

safety recommendations 2-1  
 sample configuration text file 3-9  
 secondary domain name server 5-12  
 sending ringback tone to the caller 5-34  
 send special character O 5-38  
 send special character P 5-38  
 services  
 basic 1-8  
 setting a password 5-3  
 setting audio codecs 4-7



- setting the low-bit-rate codec 4-7
- setting up user IDs 4-3
- signaling data packets 5-26
- signaling image upgrade 3-26
- SigTimer parameter 5-31
- silence suppression 4-7, 5-24
- single-mode registration 4-3
- slow-start procedure 5-33
- software download from CCO 3-7, 3-8
- software specifications (all protocols) C-3
- specifying a preconfigured VLAN ID 3-3
- specifying VLAN CoS bit value (802.1P priority) for UDP packets 3-4
- specifying VLAN CoS bit value for TCP packets 3-4
- standard payload type 5-33
- statically assigning Cisco ATA IP address 5-9
- statically assigning Cisco ATA route 5-9
- statically assigning Cisco ATA subnet mask 5-10
- statically configuring various IP addresses 3-2
- StaticIP 3-20
- StaticIP parameter 5-9
- StaticNetMask 3-20
- StaticNetMask parameter 5-10
- static network router probing 5-35
- StaticRoute 3-20
- StaticRoute parameter 5-9
- strongest encryption key 5-7
- subscribed features 5-27
- supplementary services 1-9, 4-10
  - cancelling A-1
  - common A-1
- syslog 9-5
  - IP address 9-5
  - priority value 9-5
  - tag 9-5
  - time\_offset 9-5
- SyslogCtrl 5-62
- SyslogIP 5-61
- system diagnostics 9-5

---

**T**

- TFTP server IP address 3-18
- TFTP server name 3-18
- TFTP server usage enabled 5-4
- TftpURL parameter 5-5
- three-way calling configuration 5-27, 5-28
- timeout values 5-31
- time-stamping incoming calls 5-36
- time-to-live value 4-4
- time to live value for H.323 Gatekeeper registration 5-14
- time zone configuration 5-36
- TimeZone parameter 5-36
- tone
  - reorder 5-44
- tone parameters 5-41, 5-43
- tone parameter syntax
  - basic format 5-41
  - extended formats 5-43
- tones 5-41
  - syntax 5-41
- transmitting-audio codec 5-22
- troubleshooting
  - general tips 9-1
  - installation 9-3
  - upgrade issues 9-3
- two-way cut-through of voice path 5-33
- TxCodec parameter 5-22
- Type of Service (ToS) bits 5-26

---

**U**

- UID0 parameter 5-16
- UID1 parameter 5-17
- UIPassword parameter 5-3, 9-13
- UIPassword prompt configuration setting 5-36
- unique configuration file 3-10, 3-17
- upgrading firmware from TFTP server 8-1
- upgrading software

- using executable file **8-2**
- upgrading software from TFTP server **8-1**
- upgrading the signaling image **3-26**
- URL of TFTP server **5-5**
- UseLoginID **5-19**
- UseLoginID parameter **5-19**
- User ID for Phone 1 port **5-16**
- User ID for Phone 2 port **5-17**
- user IDs **4-3**
- User Interface (UI) Parameters **5-3**
- uses device hostname specified in DHCP option 12
  - configuration **5-36**
- UseTFTP parameter **5-4**
- main disconnecting device **2-2**
- No. 26 AWG **2-4**
- product disposal **2-1**
- web configuration disabling **5-35**

---

## V

- version parameter **5-63**
- version parameter for configuration file **5-63**
- VLAN ID **5-35**
- VLAN ID example **3-4**
- VLAN IP encapsulation **5-35**
- VLAN-related parameters **3-3**
- VLAN Setting parameter **5-12**
- VLAN tagging **3-2**
- voice codecs **1-7**
- voice configuration menu **3-21**
- voice data packets **5-26**
- Voice Menu Codes
  - configuration parameters **B-2**
  - information options **B-1**
  - software upgrade **B-4**

---

## W

- warnings
  - circuit breaker (15A) **2-4**
  - installation **2-1**
  - lightning activity **2-2**