



Cisco Aironet 1530 Series Outdoor Access Point Hardware Installation Guide

First Published: December, 2013

Last Updated: July 9, 2019

Cisco Systems, Inc.

www.cisco.com

Cisco has more than 200 offices worldwide. Addresses, phone numbers, and fax numbers are listed on the Cisco website at www.cisco.com/go/offices.

THE SPECIFICATIONS AND INFORMATION REGARDING THE PRODUCTS IN THIS MANUAL ARE SUBJECT TO CHANGE WITHOUT NOTICE. ALL STATEMENTS, INFORMATION, AND RECOMMENDATIONS IN THIS MANUAL ARE BELIEVED TO BE ACCURATE BUT ARE PRESENTED WITHOUT WARRANTY OF ANY KIND, EXPRESS OR IMPLIED. USERS MUST TAKE FULL RESPONSIBILITY FOR THEIR APPLICATION OF ANY PRODUCTS.

THE SOFTWARE LICENSE AND LIMITED WARRANTY FOR THE ACCOMPANYING PRODUCT ARE SET FORTH IN THE INFORMATION PACKET THAT SHIPPED WITH THE PRODUCT AND ARE INCORPORATED HEREIN BY THIS REFERENCE. IF YOU ARE UNABLE TO LOCATE THE SOFTWARE LICENSE OR LIMITED WARRANTY, CONTACT YOUR CISCO REPRESENTATIVE FOR A COPY.

The following information is for FCC compliance of Class A devices: This equipment has been tested and found to comply with the limits for a Class A digital device, pursuant to part 15 of the FCC rules. These limits are designed to provide reasonable protection against harmful interference when the equipment is operated in a commercial environment. This equipment generates, uses, and can radiate radio-frequency energy and, if not installed and used in accordance with the instruction manual, may cause harmful interference to radio communications. Operation of this equipment in a residential area is likely to cause harmful interference, in which case users will be required to correct the interference at their own expense.

The following information is for FCC compliance of Class B devices: This equipment has been tested and found to comply with the limits for a Class B digital device, pursuant to part 15 of the FCC rules. These limits are designed to provide reasonable protection against harmful interference in a residential installation. This equipment generates, uses and can radiate radio frequency energy and, if not installed and used in accordance with the instructions, may cause harmful interference to radio communications. However, there is no guarantee that interference will not occur in a particular installation. If the equipment causes interference to radio or television reception, which can be determined by turning the equipment off and on, users are encouraged to try to correct the interference by using one or more of the following measures:

- Reorient or relocate the receiving antenna.
- Increase the separation between the equipment and receiver.
- Connect the equipment into an outlet on a circuit different from that to which the receiver is connected.
- Consult the dealer or an experienced radio/TV technician for help.

Modifications to this product not authorized by Cisco could void the FCC approval and negate your authority to operate the product.

The Cisco implementation of TCP header compression is an adaptation of a program developed by the University of California, Berkeley (UCB) as part of UCB's public domain version of the UNIX operating system. All rights reserved. Copyright © 1981, Regents of the University of California.

NOTWITHSTANDING ANY OTHER WARRANTY HEREIN, ALL DOCUMENT FILES AND SOFTWARE OF THESE SUPPLIERS ARE PROVIDED "AS IS" WITH ALL FAULTS. CISCO AND THE ABOVE-NAMED SUPPLIERS DISCLAIM ALL WARRANTIES, EXPRESSED OR IMPLIED, INCLUDING, WITHOUT LIMITATION, THOSE OF MERCHANTABILITY, FITNESS FOR A PARTICULAR PURPOSE AND NONINFRINGEMENT OR ARISING FROM A COURSE OF DEALING, USAGE, OR TRADE PRACTICE.

IN NO EVENT SHALL CISCO OR ITS SUPPLIERS BE LIABLE FOR ANY INDIRECT, SPECIAL, CONSEQUENTIAL, OR INCIDENTAL DAMAGES, INCLUDING, WITHOUT LIMITATION, LOST PROFITS OR LOSS OR DAMAGE TO DATA ARISING OUT OF THE USE OR INABILITY TO USE THIS MANUAL, EVEN IF CISCO OR ITS SUPPLIERS HAVE BEEN ADVISED OF THE POSSIBILITY OF SUCH DAMAGES.

Cisco and the Cisco logo are trademarks or registered trademarks of Cisco and/or its affiliates in the U.S. and other countries. To view a list of Cisco trademarks, go to this URL: www.cisco.com/go/trademarks. Third-party trademarks mentioned are the property of their respective owners. The use of the word partner does not imply a partnership relationship between Cisco and any other company. (1721R)

Any Internet Protocol (IP) addresses and phone numbers used in this document are not intended to be actual addresses and phone numbers. Any examples, command display output, network topology diagrams, and other figures included in the document are shown for illustrative purposes only. Any use of actual IP addresses or phone numbers in illustrative content is unintentional and coincidental.

© 2019 Cisco Systems, Inc. All rights reserved.



Preface	vii
Objectives	vii
Audience	vii
Organization	viii
Conventions	viii
Related Documents	xiv
Finding the Product Serial Number	xiv
Obtaining Documentation, Support, and Security Guidelines	xvi

CHAPTER 1

Overview	1-1
About the 1532 Access Point	1-1
Hardware Models	1-2
Regulatory Domains	1-2
Hardware Features	1-3
Connectors	1-3
1532I/1532E Connectors	1-3
1532I/E Connectors	1-5
Antenna Port Locations	1-7
Radio Operation	1-7
AP1532I (Internal Antenna)	1-8
AP1532E (External Antenna)	1-8
Multiple Power Sources	1-8
Power injectors	1-9
Ethernet (PoE) Ports	1-10
Optional Hardware	1-10
Network Deployment Examples	1-11
Wireless Backhaul	1-11
Point-to-Point Bridging	1-11
Point-to-Multipoint Bridging	1-12
Point-to-Multipoint Mesh Network	1-14
Layer 3 Network Operation	1-15

CHAPTER 2

Installing the Access Point 2-1

- Unpacking the Access Point 2-2
 - Package Contents 2-2
- Tools and Hardware 2-2
 - Optional Tools and Hardware 2-2
 - Optional Tools and Hardware That You Supply 2-3
- Warnings 2-3
- Safety Information 2-4
 - FCC Safety Compliance Statement 2-4
 - Safety Precautions 2-4
- Avoiding Damage to Radios in a Testing Environment 2-6
- Installation Guidelines 2-6
 - Site Surveys 2-7
 - Before Beginning the Installation 2-8
 - Becoming Familiar with Access Point Installation Components 2-8
- Mounting the Access Point 2-11
 - Installation Options 2-11
 - Access Point Mounting Orientation 2-11
 - Wall Mounting the Access Point with the Fixed Mounting Kit 2-11
 - Pole Mounting the Access Point with the Fixed Mount Kit 2-14
 - Wall Mounting the Access Point with the Pivoting Mounting Kit 2-17
 - Pole Mounting the Access Point with the Pivoting Mounting Kit 2-20
 - Horizontally Mounting the Access Point with Optional Horizontal Mount Plate 2-23
- Installing AP Cover or Solar Shield (AIR-ACC1530-CVR=) 2-27
- Installing Antennas 2-28
 - Non-Cisco Antennas 2-28
 - Safety Precautions when Installing Antennas 2-29
 - Antenna Configurations 2-29
 - Integrated Antenna Option 2-29
 - External Antenna Mounting Configurations 2-30
 - Antenna N-Type Connector Locations 2-38
 - Installing a Lightning Arrestor 2-38
 - Installation Considerations 2-38
 - Installation Notes 2-39
 - Installing the Lightning Arrestor Outdoors 2-39
 - Cable for the Lightning Arrestor 2-40
- Grounding the Access Point 2-40
- Powering the Access Point 2-40

Connecting a 1530 Series Power Injector	2-42
Connecting an Ethernet Cable to the Access Point	2-43
Connecting a DC Power Cable to the Access Point	2-45
Connecting Streetlight AC Power	2-50
Wiring the Streetlight Power Tap Adapter to the AC/DC Power Adapter	2-52
Configuring the Access Point	2-53
What to Do Next	2-54

CHAPTER 3**Troubleshooting 3-1**

Guidelines for Using the Access Points	3-2
Important Notes	3-2
Convergence Delays	3-2
Bridge Loop	3-3
Controller DHCP Server	3-3
MAP Data Traffic	3-3
Controller MAC Filter List	3-3
Using DHCP Option 43	3-3
Monitoring the Access Point LEDs	3-4
Verifying Controller Association	3-6
Changing the Bridge Group Name	3-7
Access Point Power Injector	3-7
Monitoring the Power Injector LEDs	3-9
Accessing the Console Port and the Reset Button	3-9
Resetting the Access Point	3-10

APPENDIX A**Translated Safety Warnings A-1****APPENDIX B****Declarations of Conformity and Regulatory Information B-1**

Manufacturers Federal Communication Commission Declaration of Conformity Statement	B-2
Requirements of operator to register the RLAN device operating Outdoors in the 5150 -5250 MHz band and addressing possible interference issues in this band	B-3
Industry Canada	B-3
Canadian Compliance Statement	B-3
Declaration of Conformity for RF Exposure	B-5
European Community, Switzerland, Norway, Iceland, and Liechtenstein	B-6
Declaration of Conformity with regard to the R&TTE Directive 1999/5/EC & Medical Directive 93/42/EEC	B-6

Declaration of Conformity for RF Exposure B-9

- United States B-9
- Canada B-9
- European Union B-9
- Australia B-9

Guidelines for Operating Cisco Aironet Access Points in Japan B-10

- Japanese Translation B-10
- English Translation B-10
- VCCI Statement for Japan B-11

Administrative Rules for Cisco Aironet Access Points in Taiwan B-11

- Chinese Translation B-12
- English Translation B-13
- Chinese Translation B-13
- English Translation B-13
- Statement 371—Power Cable and AC Adapter B-14
 - English Translation B-14
- EU Declaration of Conformity B-14

Operation of Cisco Aironet Access Points in Brazil B-14

- Access Point Models B-14
- Regulatory Information B-15
- Portuguese Translation B-15
- English Translation B-15

APPENDIX C Channels and Power Levels C-1

APPENDIX D Access Point Data Sheet D-1

APPENDIX E Access Point Pinouts E-1

APPENDIX F Configuring DHCP Option 43 F-1

GLOSSARY



Preface

This section describes the objectives, audience, organization, and conventions of the *Cisco Aironet 1530 Series Outdoor Access Point Hardware Installation Guide*.

Objectives

This publication explains the steps for installing the Cisco Aironet 1530 Series Outdoor Access Point (called the *access point* in this document). The access point is available in an internal antenna (1532I) or an external antenna (1532E) version.

The 1532 model is a dual-radio platform that supports dual-band (2.4- and 5-GHz) operation.

Audience

This publication is for the person installing and configuring an access point for the first time. The installer should be familiar with network structures, terms, and concepts.

Warning

Only trained and qualified personnel should be allowed to install, replace, or service this equipment. Statement 1030

Warning

This equipment must be installed in restricted access locations in Norway, Finland, and Sweden. Only trained and qualified personnel are allowed to install, replace, or service this equipment as instructed in this installation guide.

Organization

This guide contains the following sections:

Chapter	Title	Description
Chapter 1	Overview	Describes the major components and features of the access point.
Chapter 2	Installing the Access Point	Provides warnings, safety information, and mounting information you need to install your access point.
Chapter 3	Troubleshooting	Provides basic troubleshooting procedures for the access point.
Appendix A	Translated Safety Warnings	Indicates how to access the document that provides translations of the safety warnings that appear in this publication.
Appendix B	Declarations of Conformity and Regulatory Information	Describes the regulatory conventions to which the access point conforms and provides guidelines for operating access points in Japan.
Appendix C	Channels and Power Levels	Indicates how to access the document that lists the access point radio channels and the maximum power levels supported by the world regulatory domains.
Appendix D	Access Point Data Sheet	Lists technical specifications for the access point.
Appendix E	Access Point Pinouts	Describes the connector pinouts for the access point.
Appendix F	Configuring DHCP Option 43	Describes the procedure to configure DHCP Option 43.

Conventions

This publication uses the following conventions:

Convention	Description
boldface font	Commands, command options, and keywords are in boldface.
<i>italic font</i>	Arguments for which you supply values are in italics.
[]	Elements in square brackets are optional.
screen font	Terminal sessions and information the system displays are in screen font.
boldface screen font	Information you must enter is in boldface screen font.
<i>italic screen font</i>	Arguments for which you supply values are in italic screen font.

Convention	Description
^	The symbol ^ represents the key labeled Control. For example, the key combination ^D in a screen display means hold down the Control key while you press the D key.
< >	Nonprinting characters, such as passwords, are in angle brackets.

Notes use the following conventions:



Note

Means *reader take note*. Notes contain helpful suggestions or references to materials not contained in this manual.

Cautions use the following conventions:



Caution

Means *reader be careful*. In this situation, you might do something that could result in equipment damage or loss of data.

Warnings use the following conventions:



Warning

IMPORTANT SAFETY INSTRUCTIONS

This warning symbol means danger. You are in a situation that could cause bodily injury. Before you work on any equipment, be aware of the hazards involved with electrical circuitry and be familiar with standard practices for preventing accidents. Use the statement number provided at the end of each warning to locate its translation in the translated safety warnings that accompanied this device. Statement 1071

SAVE THESE INSTRUCTIONS

Waarschuwing

BELANGRIJKE VEILIGHEIDSINSTRUCTIES

Dit waarschuwingssymbool betekent gevaar. U verkeert in een situatie die lichamelijk letsel kan veroorzaken. Voordat u aan enige apparatuur gaat werken, dient u zich bewust te zijn van de bij elektrische schakelingen betrokken risico's en dient u op de hoogte te zijn van de standaard praktijken om ongelukken te voorkomen. Gebruik het nummer van de verklaring onderaan de waarschuwing als u een vertaling van de waarschuwing die bij het apparaat wordt geleverd, wilt raadplegen.

BEWAAR DEZE INSTRUCTIES

Varoitus TÄRKEITÄ TURVALLISUUSOHJEITA

Tämä varoitusmerkki merkitsee vaaraa. Tilanne voi aiheuttaa ruumiillisia vammoja. Ennen kuin käsittelet laitteistoa, huomioi sähköpiirien käsittelemiseen liittyvät riskit ja tutustu onnettomuuksien yleisiin ehkäisytapoihin. Turvallisuusvaroitusten käännökset löytyvät laitteen mukana toimitettujen käännettyjen turvallisuusvaroitusten joukosta varoitusten lopussa näkyvien lausuntonumeroiden avulla.

SÄILYTÄ NÄMÄ OHJEET

Attention IMPORTANTES INFORMATIONS DE SÉCURITÉ

Ce symbole d'avertissement indique un danger. Vous vous trouvez dans une situation pouvant entraîner des blessures ou des dommages corporels. Avant de travailler sur un équipement, soyez conscient des dangers liés aux circuits électriques et familiarisez-vous avec les procédures couramment utilisées pour éviter les accidents. Pour prendre connaissance des traductions des avertissements figurant dans les consignes de sécurité traduites qui accompagnent cet appareil, référez-vous au numéro de l'instruction situé à la fin de chaque avertissement.

CONSERVEZ CES INFORMATIONS

Warnung WICHTIGE SICHERHEITSHINWEISE

Dieses Warnsymbol bedeutet Gefahr. Sie befinden sich in einer Situation, die zu Verletzungen führen kann. Machen Sie sich vor der Arbeit mit Geräten mit den Gefahren elektrischer Schaltungen und den üblichen Verfahren zur Vorbeugung vor Unfällen vertraut. Suchen Sie mit der am Ende jeder Warnung angegebenen Anweisungsnummer nach der jeweiligen Übersetzung in den übersetzten Sicherheitshinweisen, die zusammen mit diesem Gerät ausgeliefert wurden.

BEWAHREN SIE DIESE HINWEISE GUT AUF.

Avvertenza IMPORTANTI ISTRUZIONI SULLA SICUREZZA

Questo simbolo di avvertenza indica un pericolo. La situazione potrebbe causare infortuni alle persone. Prima di intervenire su qualsiasi apparecchiatura, occorre essere al corrente dei pericoli relativi ai circuiti elettrici e conoscere le procedure standard per la prevenzione di incidenti. Utilizzare il numero di istruzione presente alla fine di ciascuna avvertenza per individuare le traduzioni delle avvertenze riportate in questo documento.

CONSERVARE QUESTE ISTRUZIONI

Advarsel VIKTIGE SIKKERHETSINSTRUKSJONER

Dette advarselssymbolet betyr fare. Du er i en situasjon som kan føre til skade på person. Før du begynner å arbeide med noe av utstyret, må du være oppmerksom på farene forbundet med elektriske kretser, og kjenne til standardprosedyrer for å forhindre ulykker. Bruk nummeret i slutten av hver advarsel for å finne oversettelsen i de oversatte sikkerhetsadvarslene som fulgte med denne enheten.

TA VARE PÅ DISSE INSTRUKSJONENE

Aviso INSTRUÇÕES IMPORTANTES DE SEGURANÇA

Este símbolo de aviso significa perigo. Você está em uma situação que poderá ser causadora de lesões corporais. Antes de iniciar a utilização de qualquer equipamento, tenha conhecimento dos perigos envolvidos no manuseio de circuitos elétricos e familiarize-se com as práticas habituais de prevenção de acidentes. Utilize o número da instrução fornecido ao final de cada aviso para localizar sua tradução nos avisos de segurança traduzidos que acompanham este dispositivo.

GUARDE ESTAS INSTRUÇÕES

¡Advertencia! INSTRUCCIONES IMPORTANTES DE SEGURIDAD

Este símbolo de aviso indica peligro. Existe riesgo para su integridad física. Antes de manipular cualquier equipo, considere los riesgos de la corriente eléctrica y familiarícese con los procedimientos estándar de prevención de accidentes. Al final de cada advertencia encontrará el número que le ayudará a encontrar el texto traducido en el apartado de traducciones que acompaña a este dispositivo.

GUARDE ESTAS INSTRUCCIONES

Varning! VIKTIGA SÄKERHETSANVISNINGAR

Denna varningssignal signalerar fara. Du befinner dig i en situation som kan leda till personskada. Innan du utför arbete på någon utrustning måste du vara medveten om farorna med elkretsar och känna till vanliga förfaranden för att förebygga olyckor. Använd det nummer som finns i slutet av varje varning för att hitta dess översättning i de översatta säkerhetsvarningar som medföljer denna anordning.

SPARA DESSA ANVISNINGAR

Figyelem FONTOS BIZTONSÁGI ELOÍRÁSOK

Ez a figyelmeztető jel veszélyre utal. Sérülésveszélyt rejtő helyzetben van. Mielőtt bármely berendezésen munkát végezte, legyen figyelemmel az elektromos áramkörök okozta kockázatokra, és ismerkedjen meg a szokásos balesetvédelmi eljárásokkal. A kiadványban szereplő figyelmeztetések fordítása a készülékhez mellékelt biztonsági figyelmeztetések között található; a fordítás az egyes figyelmeztetések végén látható szám alapján kereshető meg.

ORIZZE MEG EZEKET AZ UTASÍTÁSOKAT!

Предупреждение ВАЖНЫЕ ИНСТРУКЦИИ ПО СОБЛЮДЕНИЮ ТЕХНИКИ БЕЗОПАСНОСТИ

Этот символ предупреждения обозначает опасность. То есть имеет место ситуация, в которой следует опасаться телесных повреждений. Перед эксплуатацией оборудования выясните, каким опасностям может подвергаться пользователь при использовании электрических цепей, и ознакомьтесь с правилами техники безопасности для предотвращения возможных несчастных случаев. Воспользуйтесь номером заявления, приведенным в конце каждого предупреждения, чтобы найти его переведенный вариант в переводе предупреждений по безопасности, прилагаемом к данному устройству.

СОХРАНИТЕ ЭТИ ИНСТРУКЦИИ

警告 重要的安全性说明

此警告符号代表危险。您正处于可能受到严重伤害的工作环境中。在您使用设备开始工作之前，必须充分意识到触电的危险，并熟练掌握防止事故发生的标准工作程序。请根据每项警告结尾提供的声明号码来找到此设备的安全性警告说明的翻译文本。

请保存这些安全性说明

警告 安全上の重要な注意事項

「危険」の意味です。人身事故を予防するための注意事項が記述されています。装置の取り扱い作業を行うときは、電気回路の危険性に注意し、一般的な事故防止策に留意してください。警告の各国語版は、各注意事項の番号を基に、装置に付属の「Translated Safety Warnings」を参照してください。

これらの注意事項を保管しておいてください。

주의 重要 안전 지침

이 경고 기호는 위험을 나타냅니다. 작업자가 신체 부상을 일으킬 수 있는 위험한 환경에 있습니다. 장비에 작업을 수행하기 전에 전기 회로와 관련된 위험을 숙지하고 표준 작업 관례를 숙지하여 사고를 방지하십시오. 각 경고의 마지막 부분에 있는 경고문 번호를 참조하여 이 장치와 함께 제공되는 번역된 안전 경고문에서 해당 번역문을 찾으십시오.

이 지시 사항을 보관하십시오.

Aviso INSTRUÇÕES IMPORTANTES DE SEGURANÇA

Este símbolo de aviso significa perigo. Você se encontra em uma situação em que há risco de lesões corporais. Antes de trabalhar com qualquer equipamento, esteja ciente dos riscos que envolvem os circuitos elétricos e familiarize-se com as práticas padrão de prevenção de acidentes. Use o número da declaração fornecido ao final de cada aviso para localizar sua tradução nos avisos de segurança traduzidos que acompanham o dispositivo.

GUARDE ESTAS INSTRUÇÕES

Advarsel VIGTIGE SIKKERHEDSANVISNINGER

Dette advarselssymbol betyder fare. Du befinder dig i en situation med risiko for legemeskade. Før du begynder arbejde på udstyr, skal du være opmærksom på de involverede risici, der er ved elektriske kredsløb, og du skal sætte dig ind i standardprocedurer til undgåelse af ulykker. Brug erklæringsnummeret efter hver advarsel for at finde oversættelsen i de oversatte advarsler, der fulgte med denne enhed.

GEM DISSE ANVISNINGER

تحذير

إرشادات الأمان الهامة

يوضح رمز التحذير هذا وجود خطر. وهذا يعني أنك متواجد في مكان قد ينتج عنه التعرض لإصابات. قبل بدء العمل، احذر مخاطر التعرض للصدمات الكهربائية وكن على علم بالإجراءات القياسية للحيلولة دون وقوع أي حوادث. استخدم رقم البيان الموجود في آخر كل تحذير لتحديد مكان ترجمته داخل تحذيرات الأمان المترجمة التي تأتي مع الجهاز. قم بحفظ هذه الإرشادات

Upozorenje VAŽNE SIGURNOSNE NAPOMENE

Ovaj simbol upozorenja predstavlja opasnost. Nalazite se u situaciji koja može prouzročiti tjelesne ozljede. Prije rada s bilo kojim uređajem, morate razumjeti opasnosti vezane uz električne sklopove, te biti upoznati sa standardnim načinima izbjegavanja nesreća. U prevedenim sigurnosnim upozorenjima, priloženima uz uređaj, možete prema broju koji se nalazi uz pojedino upozorenje pronaći i njegov prijevod.

SAČUVAJTE OVE UPUTE

Upozornění DŮLEŽITÉ BEZPEČNOSTNÍ POKYNY

Tento upozorňující symbol označuje nebezpečí. Jste v situaci, která by mohla způsobit nebezpečí úrazu. Před prací na jakémkoliv vybavení si uvědomte nebezpečí související s elektrickými obvody a seznamte se se standardními opatřeními pro předcházení úrazům. Podle čísla na konci každého upozornění vyhledejte jeho překlad v přeložených bezpečnostních upozorněních, která jsou přiložena k zařízení.

USCHOVEJTE TYTO POKYNY

Προειδοποίηση ΣΗΜΑΝΤΙΚΕΣ ΟΔΗΓΙΕΣ ΑΣΦΑΛΕΙΑΣ

Αυτό το προειδοποιητικό σύμβολο σημαίνει κίνδυνο. Βρίσκεστε σε κατάσταση που μπορεί να προκαλέσει τραυματισμό. Πριν εργαστείτε σε οποιοδήποτε εξοπλισμό, να έχετε υπόψη σας τους κινδύνους που σχετίζονται με τα ηλεκτρικά κυκλώματα και να έχετε εξοικειωθεί με τις συνηθισμένες πρακτικές για την αποφυγή ατυχημάτων. Χρησιμοποιήστε τον αριθμό δήλωσης που παρέχεται στο τέλος κάθε προειδοποίησης, για να εντοπίσετε τη μετάφρασή της στις μεταφρασμένες προειδοποιήσεις ασφαλείας που συνοδεύουν τη συσκευή.

ΦΥΛΑΞΤΕ ΑΥΤΕΣ ΤΙΣ ΟΔΗΓΙΕΣ

אזהרה

הוראות בטיחות חשובות

סימן אזהרה זה מסמל סכנה. אתה נמצא במצב העלול לגרום לפציעה. לפני שתעבוד עם ציוד כלשהו, עליך להיות מודע לסכנות הכרוכות במגעלים חשמליים ולהכיר את הנהלים המקובלים למניעת תאונות. השתמש במספר ההוראה המסופק בסופה של כל אזהרה כדי לאתר את התרגום באזהרות הבטיחות המתורגמות שמצורפות להתקן.

שמור הוראות אלה

Opomena VAŽNI BEZBEDNOSNI NAPATCTVIJA

Симболот за предупредување значи опасност. Се наоѓате во ситуација што може да предизвика телесни повреди. Пред да работите со опремата, бидете свесни за ризикот што постои кај електричните кола и треба да ги познавате стандардните постапки за спречување на несреќни случаи. Искористете го бројот на изјавата што се наоѓа на крајот на секое предупредување за да го најдете неговиот период во преведените безбедносни предупредувања што се испорачани со уредот. ЧУВАЈТЕ ГИ ОВИЕ НАПАТСТВИЈА

Ostrzeżenie WAŻNE INSTRUKCJE DOTYCZĄCE BEZPIECZEŃSTWA

Ten symbol ostrzeżenia oznacza niebezpieczeństwo. Zachodzi sytuacja, która może powodować obrażenia ciała. Przed przystąpieniem do prac przy urządzeniach należy zapoznać się z zagrożeniami związanymi z układami elektrycznymi oraz ze standardowymi środkami zapobiegania wypadkom. Na końcu każdego ostrzeżenia podano numer, na podstawie którego można odszukać tłumaczenie tego ostrzeżenia w dołączonym do urządzenia dokumencie z tłumaczeniami ostrzeżeń.

NINIEJSZE INSTRUKCJE NALEŻY ZACHOWAĆ

Upozornenie DŹLEŻITÉ BEZPEČNOSTNÉ POKYNY

Tento varovný symbol označuje nebezpečenstvo. Nachádzate sa v situácii s nebezpečenstvom úrazu. Pred prácou na akomkoľvek vybavení si uvedomte nebezpečenstvo súvisiace s elektrickými obvodmi a oboznámte sa so štandardnými opatreniami na predchádzanie úrazom. Podľa čísla na konci každého upozornenia vyhľadajte jeho preklad v preložených bezpečnostných upozorneniach, ktoré sú priložené k zariadeniu.

USCHOVAJTE SI TENTO NÁVOD

Related Documents

These documents provide complete information about the access point:

- *Release Notes for Cisco Wireless LAN Controllers and Lightweight Access Points*
- *Quick Start Guide: Cisco Aironet 1530 Series Outdoor Access Points*
- *Cisco Wireless LAN Controller Configuration Guide*

Click this link to browse to the Cisco Wireless documentation home page:

<http://www.cisco.com/en/US/products/hw/wireless/index.html>

To browse to the access point documentation, click **Cisco Aironet 1530 Series** listed under “Outdoor Wireless.” The documentation can be accessed from the Support box.

To browse to the Cisco Wireless LAN Controller documentation, click **Standalone Controllers** listed under “Wireless LAN Controllers.” The documentation can be accessed from the Support box.

Finding the Product Serial Number

The access point serial number is on the side of the access point (refer to [Figure 1](#)).

Figure 1 Location of Serial Number Label

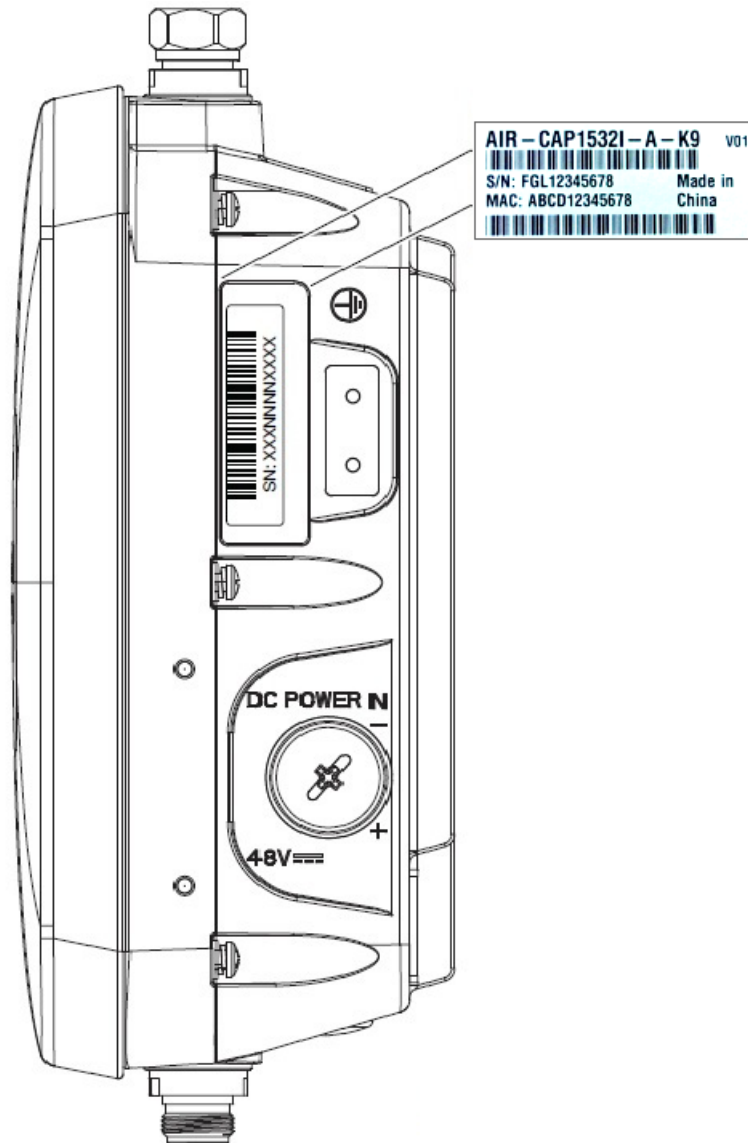

The access point serial number label contains the following information:

- Model number, such as AIR-CAP1532E-x-K9.
- Serial number, such as WCN0636279B (11 alphanumeric digits).
- Access point MAC address, for example 68BDABF54600 (12 hexadecimal digits). It is located under the serial number.

You need your product serial number when requesting support from the Cisco Technical Assistance Center.

Obtaining Documentation, Support, and Security Guidelines

For information on obtaining documentation and support, providing documentation feedback, security guidelines, and recommended aliases and general Cisco documents, see the monthly *What's New in Cisco Product Documentation*, which also lists all new and revised Cisco technical documentation, at:

<http://www.cisco.com/en/US/docs/general/whatsnew/whatsnew.html>

To view all new wireless documentation, click on **Wireless**.



Overview

The Cisco Aironet 1530 Series Outdoor Access Point (hereafter called the *access point* or *AP*) is a wireless outdoor access point which is designed for use in a variety of network configurations. The access point supports wireless client access, point-to-point bridging, point-to-multipoint bridging, and point-to-multipoint mesh wireless connectivity.

About the 1532 Access Point

The 1532 access point supports two radios (2.4-GHz and 5-GHz) and provides client access using the unlicensed RF Wi-Fi spectrum. The 2.4 GHz radio is used for client access and the 5 GHz radio can be dedicated for backhaul traffic or can be used for both backhaul and client access. Depending on the radio, the access point can support 1 to 300 Mb/s data rates (for specific data rates, refer to [Appendix D, “Access Point Data Sheet”](#)).

The access point is a standalone unit that can be wall, pole or tower mounted. The access point can also operate as a relay node for other access points not directly connected to a wired network. Intelligent wireless routing is provided by the patented Adaptive Wireless Path Protocol (AWPP). This enables each access point to identify its neighbors and intelligently choose the optimal path to the wired network by calculating the cost of each path in terms of signal strength and the number of hops required to get to a controller.

The access point can be configured, monitored, and operated through a Cisco wireless LAN controller (hereafter called a *controller*) as described in the *Cisco Wireless LAN Controller Configuration Guide*. The *Cisco Wireless Mesh Access Points, Design and Deployment Guide, Release 7.6* describes how to plan and initially configure the Cisco mesh network, which supports wireless point-to-point, point-to-multipoint, and mesh deployments. The controllers use a browser-based management system, a command-line interface (CLI), or the Cisco Prime Infrastructure (PI) network management system to manage the controller and the associated access points. The access point supports hardware-based advanced encryption standard (AES) encryption between wireless nodes to provide end-to-end security. The access point can also be deployed in an autonomous mode and be configured via the CLI.

This chapter provides information on the following topics:

- [Hardware Models, page 1-2](#)
- [Hardware Features, page 1-3](#)
- [Network Deployment Examples, page 1-11](#)

Hardware Models

The model numbers (or part numbers) and configuration for the Cisco Aironet 1532 Outdoor Access Points are described in [Table 1-1](#).

For a detailed description of the declarations of conformity and regulatory information for the 1532 access points refer to [Appendix B, “Declarations of Conformity and Regulatory Information.”](#)

Table 1-1 1532 Access Point Model Numbers and Descriptions

Model (or part number)	Configuration
AIR-CAP1532I-x-K9	The AP 1532I has integrated antennas and contains a 2.4 GHz and 5 GHz radio with an option to configure in centralized, Flexconnect, or mesh mode. This is a stand alone unit that can be wall, pole or tower mounted. It can also operate as a relay node for other access points that are not directly connected to a wired network.
AIR-CAP1532E-x-K9	The AP 1532E has 4 external antenna ports and contains a 2.4 GHz and 5 GHz radio with an option to configure in centralized, Flexconnect, or mesh mode. This is a stand alone unit that can be wall, pole or tower mounted. It can also operate as a relay node for other access points that are not directly connected to a wired network.

Regulatory Domains

The “-x” in the 1532 model numbers represent the domain. For example, in AIR-CAP1532I-x-K9, the -x represents a regulatory domain for a specific country. For specific regulatory domains supported by each 1532 access point model, refer to the Wireless LAN Compliance Status at the following URL:

http://www.cisco.com/en/US/prod/collateral/wireless/ps5679/ps5861/product_data_sheet0900aecd80537b6a.html

Hardware Features

This section describes the hardware features of the 1532 access point models. The following hardware features are described in this section:

- [Connectors, page 1-3](#)
- [Antenna Port Locations, page 1-7](#)
- [Multiple Power Sources, page 1-8](#)
- [Ethernet \(PoE\) Ports, page 1-10](#)
- [Optional Hardware, page 1-10](#)

Connectors

[Figure 1-4](#) and [Figure 1-5](#) show the access point connectors for all models. [Figure 1-1](#) shows the bottom connectors for internal antenna model, and [Figure 1-2](#) and [Figure 1-3](#) show the external antenna Type-N connectors.



Note

The illustrations in this document show all available connections for the access point. Unused connections are capped with a connector plug to ensure the watertight integrity of the access point. Liquid-tight adapters are provided for connector openings, which can be installed before or after deploying the access point.

1532I/1532E Connectors

Figure 1-1 Access Point Models AIR-CAP1532I-x-K9 Bottom Connectors

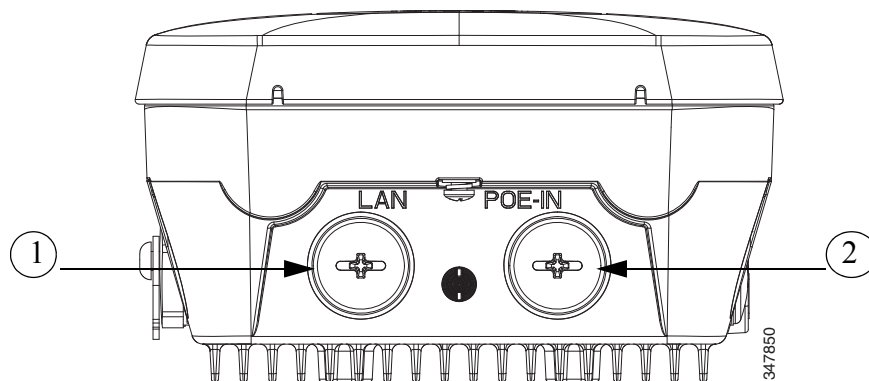

1	<p>LAN port.</p> <p>If the port is not in use, then the covering plug must be tightened to 12.5 lbf-in torque. Otherwise, it may lead to water leaking into the access point.</p>	2	<p>POE-in port.</p> <p>If the port is not in use, then the covering plug must be tightened to 12.5 lbf-in torque. Otherwise, it may lead to water leaking into the access point.</p>
----------	-----------------------------------------------------------------------------------------------------------------------------------------------------------------------------------	----------	--------------------------------------------------------------------------------------------------------------------------------------------------------------------------------------

Figure 1-2 Access Point Models AIR-CAP1532E-x-K9 Bottom Connectors

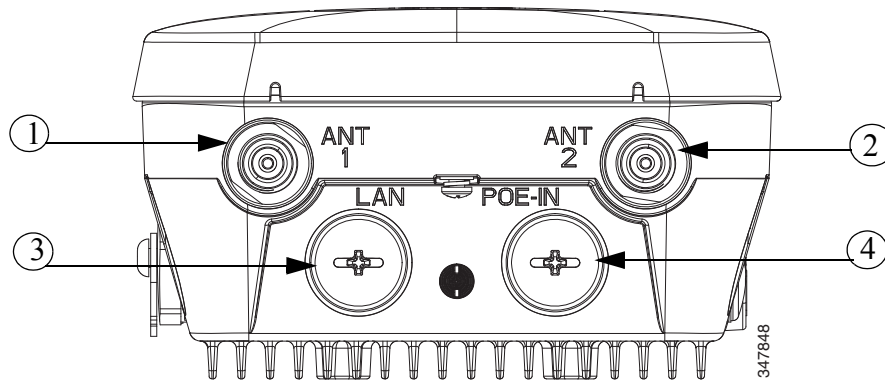

1	Antenna 1 port.	2	Antenna 2 port.
3	LAN port. If the port is not in use, then the covering plug must be tightened to 12.5 lbf-in torque. Otherwise, it may lead to water leaking into the access point.	4	POE-in port. If the port is not in use, then the covering plug must be tightened to 12.5 lbf-in torque. Otherwise, it may lead to water leaking into the access point.

Figure 1-3 Access Point Model AIR-CAP1532E-x-K9 Top Connectors

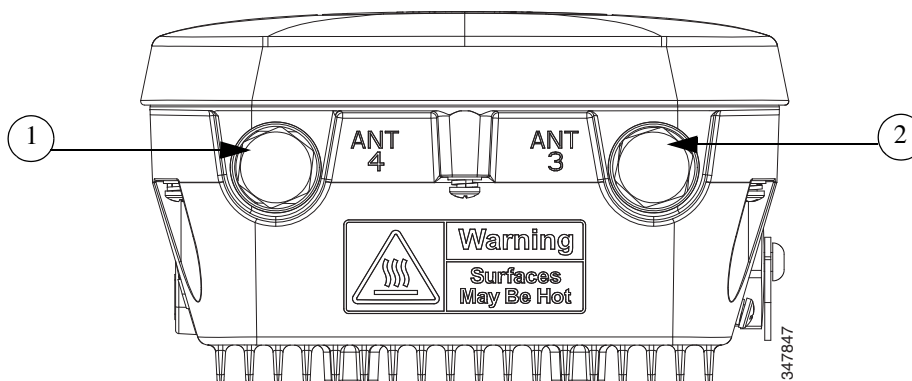

1	Antenna port 4	2	Antenna port 3
---	----------------	---	----------------



Note The AIR-CAP1532I-x-K9 does not have any top connectors.

1532I/E Connectors

Figure 1-4 Access Point Model AIR-CAP1532I-x-K9 and AIR-CAP1532E-x-K9 Left Side Connectors

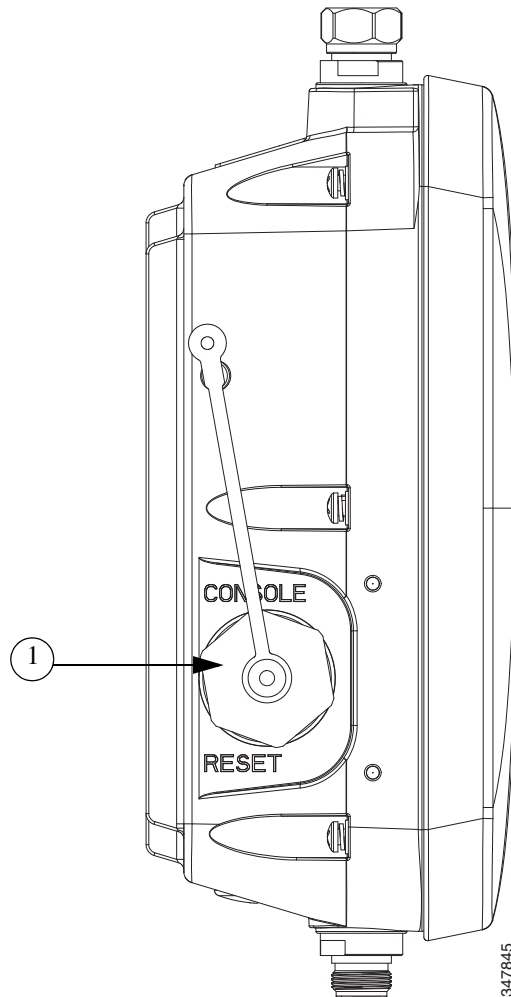

- | | |
|----------|------------------------------------------------------------------------------------------------------------------------------------------------------------------------------------------------------------------------------------------------------------------------------------------------------------------------------------------------------------------------------------------------------------------------------|
| 1 | <p>Console port and Reset button (covered)</p> <p>The console port and the reset button are under a hex-shaped sealed plug. Inspect the seal of the plug and properly tighten it at the time of installation, and also every time the plug is removed and replaced. Tighten the plug to 15 lbf-in. If you do not tighten the plug properly, it will not meet IP67 criteria, and may lead to water leaking into the unit.</p> |
|----------|------------------------------------------------------------------------------------------------------------------------------------------------------------------------------------------------------------------------------------------------------------------------------------------------------------------------------------------------------------------------------------------------------------------------------|

Figure 1-5 Access Point Model AIR-CAP1532I-x-K9 and AIR-CAP1532E-x-K9 Right Side Connectors

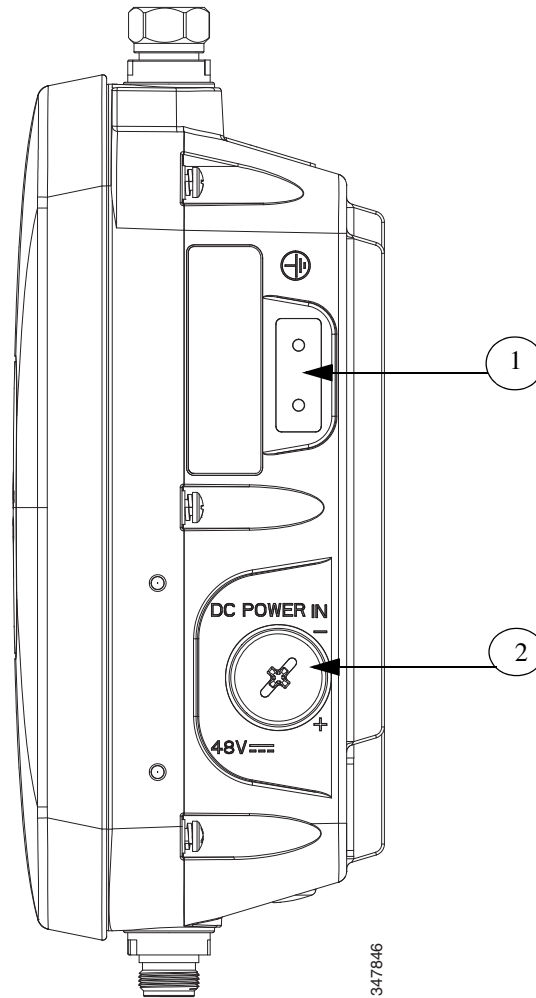

1	Ground Pad.	2	<p>DC Power-In (covered).</p> <p>If the port is not in use, then the covering plug must be tightened to 12.5 lbf-in torque. Otherwise, it may lead to water leaking into the access point.</p>
---	-------------	---	------------------------------------------------------------------------------------------------------------------------------------------------------------------------------------------------

Antenna Port Locations

Figure 1-6 shows the antenna port locations for model AIR-CAP1532E-x-K9. The ports used depend on the optional antennas ordered.

Figure 1-6 External Antenna Port Locations for Access Point Models AIR-CAP1532E-x-K9

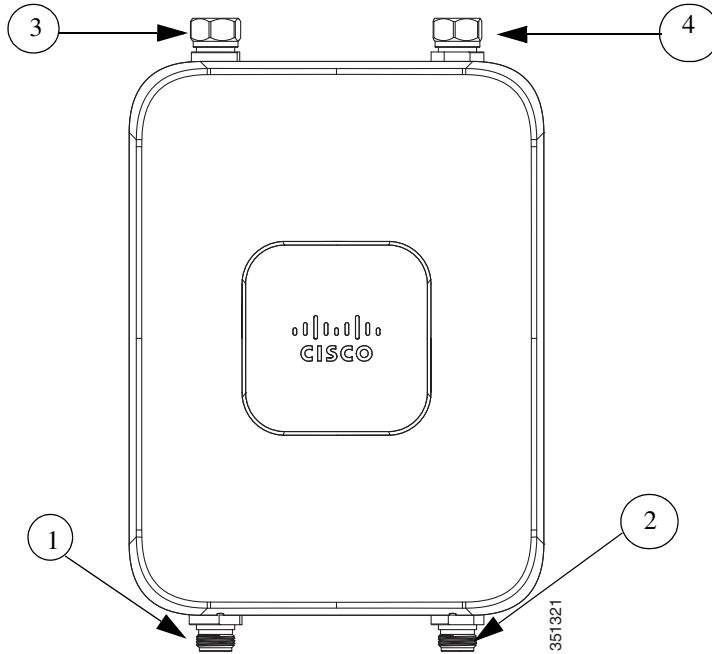

1	Antenna port 1 – Type N connector	2	Antenna port 2- Type N connector
3	Antenna port 3– Type N connector (with cap)	4	Antenna port 4- Type N connector (with cap)

Radio Operation

Warning

In order to comply with radio frequency (RF) exposure limits, the antennas should be placed no less than 20 cm (8”) from your body or nearby persons. Statement 339

Warning

Do not locate the antenna near overhead power lines or other electric light or power circuits, or where it can come into contact with such circuits. When installing the antenna, take extreme care not to come into contact with such circuits, because they may cause serious injury or death. For proper installation and grounding of the antenna, please refer to national and local codes (for example, U.S.: NFPA 70, National Electric Code, Article 180, Canada: Canadian Electrical Code, Section 54). Statement 1052

Warning

Only trained and qualified personnel should be allowed to install, replace, or service this equipment. Statement 1030

AP1532I (Internal Antenna)

The 1532I access point 802.11b/g/n radio is used primarily for local access and its 802.11a/n radio for wireless backhaul in the Mesh.

The 2 GHz b/g/n radio operates in 2.4 GHz ISM band. It supports channels 1-11 in the US, 1-13 in Europe, and 1-13 in Japan. It has 3 transmitters with a maximum total output power of 29 dBm for 802.11b/g/n operation. Output power is configurable for 8 levels in 3 dB steps. It has three receivers that enable maximum-ratio combining (MRC).

The 5 GHz a/n radio operates in the UNII-2 band (5.25 - 5.35 GHz), UNII-2 Extended/ETSI band (5.47 - 5.725 GHz), and the upper ISM band (5.725 - 5.850 GHz). It has two transmitters with a maximum total output power of 27 dBm depending on the regulatory domain. The total maximum output power for the upper ISM band is 27 dBm for A-domain. Tx power settings will change depending on the regulatory domain. Output power is configurable in 3 dB steps. Its three receivers enable maximum-ratio combining (MRC).

The 1532I access point is equipped with three integrated dual-band antennas with 3 dBi gain at 2 GHz and 5 dBi gain at 5 GHz.

AP1532E (External Antenna)

The 1532E access point is equipped with four N-type RF connectors. The 1532E can be configured via software to support dual band or single band antennas. When configured for dual band antennas, antenna ports 1 and 2 on the bottom of the unit ([Figure 1-2](#)) are used to support multiple input/multiple output (MIMO) operation on both 2.4 and 5 GHz radios. When using the Cisco Aironet AIR-ANT2547V-N or AIR-ANT2547VG-N omnidirectional antennas, the antenna can be connected directly to the access point ([Figure 2-16](#)). If the antennas are remotely located, an appropriate low loss RF cable should be used.



Note

Ensure that the antenna band mode is configured before the 1532E access point is installed.

When configured for single band antennas, antenna port 1 and antenna port 2 support MIMO operation for the 2.4 GHz radio, and antenna ports 3 and 4 ([Figure 1-3](#)) support MIMO on the 5 GHz radio. See the *Cisco Wireless LAN Controller Configuration Guide* for information on the software configuration.

Multiple Power Sources







The 1530 series access point supports these power sources:

- DC power – 24-57 VDC
- Power over Ethernet (PoE) – For more information, see [“Powering the Access Point” section on page 2-40](#).



Warning



Installation of the equipment must comply with local and national electrical codes. Statement 1074

	Warning	This equipment must be externally grounded using a customer-supplied ground wire before power is applied. Contact the appropriate electrical inspection authority or an electrician if you are uncertain that suitable grounding is available. Statement 366
	Warning	Do not work on the system or connect or disconnect cables during periods of lightning activity. Statement 1001
	Warning	Connect the unit only to DC power source that complies with the safety extra-low voltage (SELV) requirements in IEC 60950 based safety standards. Statement 1033
	Warning	To reduce the risk of fire, use only No. 26 AWG or larger telecommunication line cord. Statement 1023
	Caution	Several forms of PoE are supported. See Table Table 2-7 for the PoE options and their corresponding modes of operation.
	Caution	Do not place the power injector in an unprotected outdoor environment because water could get into the power injector and cause a short circuit and possible fire.
	Caution	When the access point is installed outdoors or in a wet or damp location, the AC branch circuit that is powering the access point should be provided with ground fault protection (GFCI), as required by Article 210 of the National Electrical Code (NEC).

Power injectors

The 1530 series access points support the following power injectors:

- AIR-PWRINJ1500-2= – 100-240 VAC input, indoor use only
- AIR-PWRINJ-30= – 100-240 VAC input, indoor use only

	Warning	To reduce the risk of fire, use only No. 26 AWG or larger telecommunications line cord. Statement 1023
	Caution	The power injector (AIR-PWRINJR4- and AIR-PWRINJ1500-2=) must be used in an indoor environment only.

**Caution**

When the access point is installed outdoors, or in a wet or damp location, the AC branch circuit that is powering the access point should be provided with ground fault protection (GFCI), as required by Article 210 of the National Electrical Code (NEC).

Ethernet (PoE) Ports

The access point supports an Ethernet uplink port (PoE-In). The access point Ethernet uplink port uses an RJ-45 connector (with weatherproofing) to link the access point to the 10BASE-T, 100BASE-T or 1000BASE-T network. The Ethernet cable is used to send and receive Ethernet data and to optionally supply inline power from the power injector or a suitably powered switch port.

**Tip**

The access point senses the Ethernet and power signals and automatically switches internal circuitry to match the cable connections.

**Warning**

To reduce the risk of fire, use only No. 26 AWG or larger telecommunication line cord. Statement 1023

The Ethernet cable must be a shielded outdoor rated Category 5e (CAT5e) or better cable. The access point senses the Ethernet and power signals and automatically switches internal circuitry to match the cable connections.

Optional Hardware

Depending on what you ordered, the following optional access point hardware may be part of your shipment:

- External antennas, depending on which ones you purchased (See [“AP1532E \(External Antenna\)” section on page 1-8](#) for information on available external antennas.)
- Wall/Pole mount bracket (AIR-ACC1530-PMK1 [=])
- Wall/Pole mount bracket with tilt mechanism, spare only (AIR-ACC1530-PMK2=)
- Street light power tap (AIR-PWR-ST-LT-R3P=), works only with the AC/DC power adapter.
- Power injector (AIR-PWRINJ1500-2=, AIR-PWRINJ-30=)
- AP cover / Solar Shield for 1532, spare only (AIR-ACC1530-CVR=)
- AC/DC power adapter, spare only (AIR-PWRADPT-1530=)
- Spare Parts kit containing extra cable glands, power connector, ground lug, etc. (AIR-ACC1530-KIT1=)

Network Deployment Examples

The access point is a wireless device designed for wireless client access and point-to-point bridging, point-to-multipoint bridging, and point-to-multipoint mesh wireless connectivity. The access point provides 5-GHz backhaul capability to link with another access point to reach a wired network connection or to provide repeater operations for other access points.

The access point plays two primary radio roles: a root access point (hereafter called a RAP) or a mesh (non-root) access point (hereafter called a MAP), which is the default role of all access points. When the access point has a fiber or wired Ethernet connection to the controller (through a switch), the radio role is called a RAP. In order to be considered a RAP, the access point must be configured as a RAP. A RAP is a parent node to any bridging or mesh network. A controller can support one or more RAPs, each one parenting the same or different wireless networks. There can be more than one RAP for the same mesh network for redundancy. RAPs and MAPs can support wireless clients on the 2.4-GHz and 5-GHz band. Client access on 5-GHz is called universal client access.

When the access point does not have a wired Ethernet connection to the controller (through a switch), the radio role is called a MAP. The MAPs have a wireless connection (through the backhaul interface) to other MAPs and finally to a RAP which has an Ethernet connection through a switch to the controller. MAPs may also have a wired Ethernet connection to a local LAN and serve as a bridge endpoint for that LAN (using a point-to-point or point-to-multipoint bridge connection).

Wireless Backhaul

The access point supports wireless backhaul capability using the 5 GHz radio to bridge to another access point to reach a wired network connection to a controller (see [Figure 1-7](#)). The access point connected to the wired network is considered a RAP in this configuration. The remote access point is considered a MAP and transfers wireless client traffic to the RAP for transfer to the wired network. Control And Provisioning of Wireless Access Points (CAPWAP) control traffic is also transferred over this bridged link.

Figure 1-7 Access Point Backhaul Example

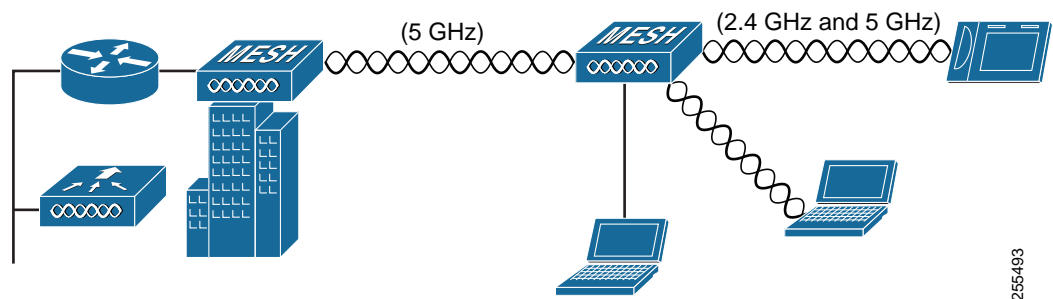

255493

Point-to-Point Bridging

The access points can be used to extend a remote network by using the 5 GHz backhaul radio to bridge the two network segments as shown in [Figure 1-8](#). To support Ethernet bridging, you must enable bridging on the controller for each access point. By default this capability is turned-off for all access points.

Wireless client access is supported; however, if bridging between tall buildings, the 2.4-GHz wireless coverage area may be limited and possibly not suitable for direct wireless client access.

Figure 1-8 Access Point Point-to-Point Bridging Example

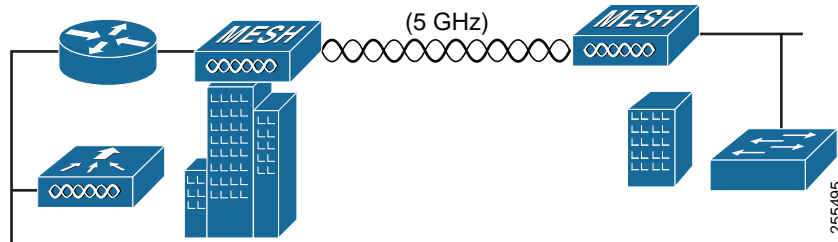

The access points can also support point-to-point bridging under autonomous mode. In this autonomous mode, the bridging can be done on the 2.4 or 5 GHz radio, but not both. In this mode, one access point is designated as the root and the other end is designated as the non-root bridge.

Figure 1-9 Access Point Point-to-Point Bridging in Autonomous Mode

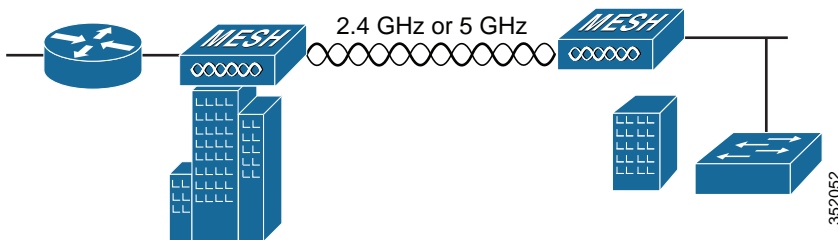

Point-to-Multipoint Bridging

The access points can be used as a RAP to connect multiple remote MAPs with their associated wired networks. By default this capability is turned-off for all access points. To support Ethernet bridging, you must enable bridging on the controller for each access point. Wireless client access can be provided over the bridging link; however, if bridging between tall buildings, the 2.4-GHz wireless coverage area may be limited and possibly not suitable for direct wireless client access. [Figure 1-10](#) illustrates an example of access point-to-multipoint bridging.

Figure 1-10 Access Point to Multipoint Bridging Example

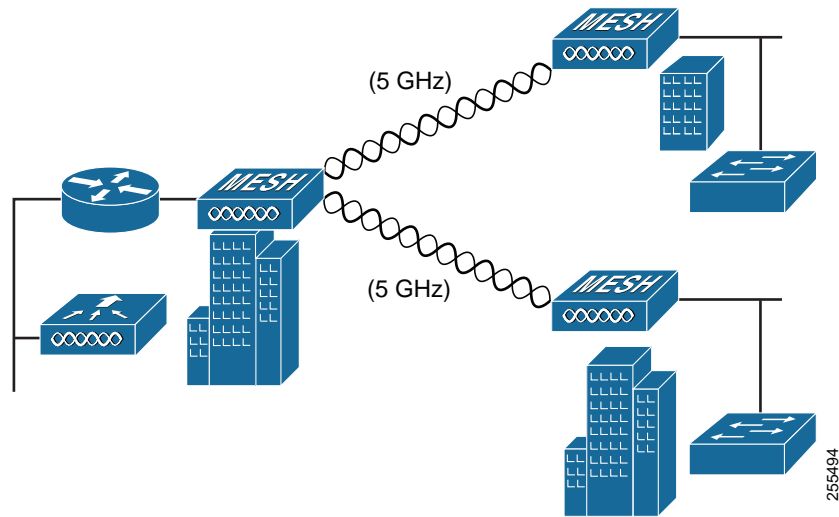

The access points can also support point-to-multipoint bridging under autonomous mode. In this autonomous mode, the bridging can be done on the 2.4 or 5 GHz radio, but not both. In this mode, one access point is designated as the root and the other end is designated as the non-root bridge.

Figure 1-11 Access Point to Multipoint Bridging in Autonomous Mode

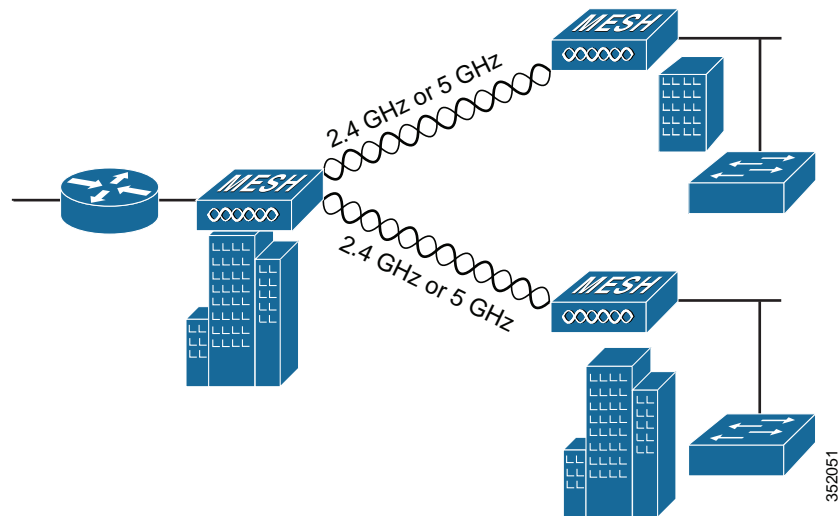

Point-to-Multipoint Mesh Network

The access point is typically deployed in a mesh network configuration. In a typical mesh deployment, one or more RAPs have a wired network connection through a switch to a controller. Other remote MAPs without wired network connections use the backhaul feature to optimally link to a RAP that is connected to the wired network. In the mesh network, the links between the access points are referred to as the *backhaul links*.

Intelligent wireless routing is provided by the Adaptive Wireless Path protocol (AWPP). This enables each MAP to identify its neighbors and intelligently choose the optimal path to the RAP with the wired network connection by calculating the cost of each path in terms of signal strength and the number of hops required to get to a controller with signal strength given priority since signal strength determines the data rate available for backhaul.

Figure 1-12 illustrates a typical mesh configuration using MAPs and RAPs.

Figure 1-12 Typical Mesh Configuration Using Access Points

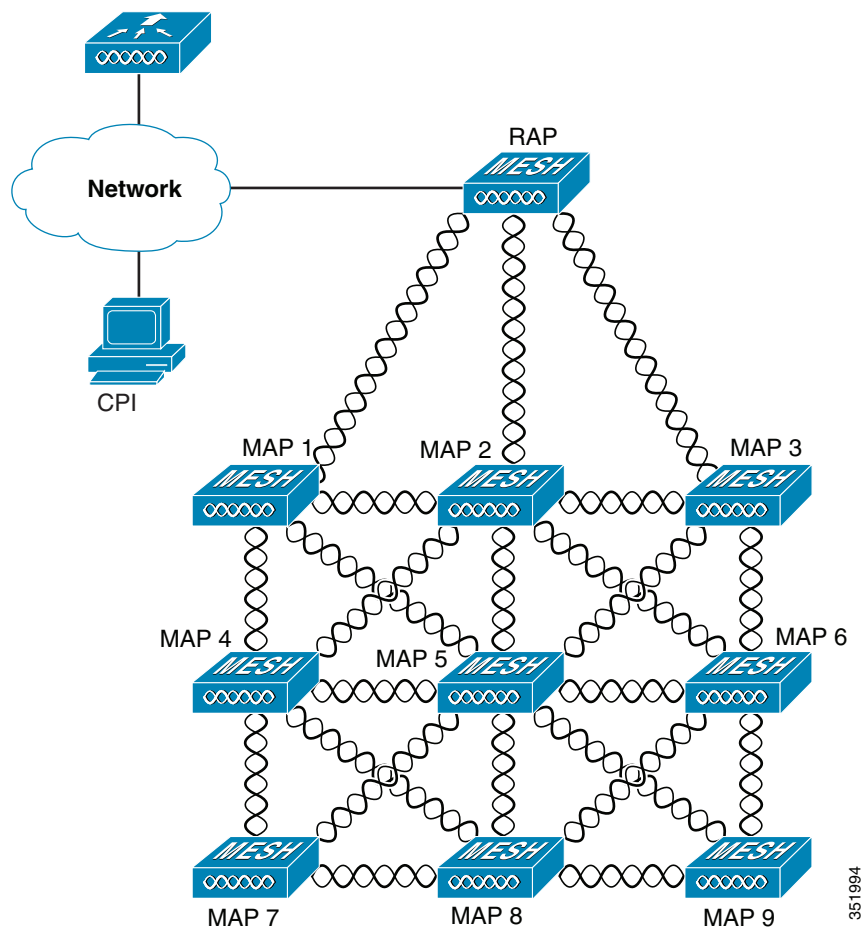

351994

Layer 3 Network Operation

The access points support Layer 3 network operation. Access points and controllers in Layer 3 configurations use IP addresses and UDP packets, which can be routed through large networks. Layer 3 operation is scalable and recommended by Cisco.

Figure 1-13 illustrates a typical Layer-3 wireless network configuration containing access points and a controller.

Figure 1-13 Typical Layer 3 Access Point Network Configuration Example

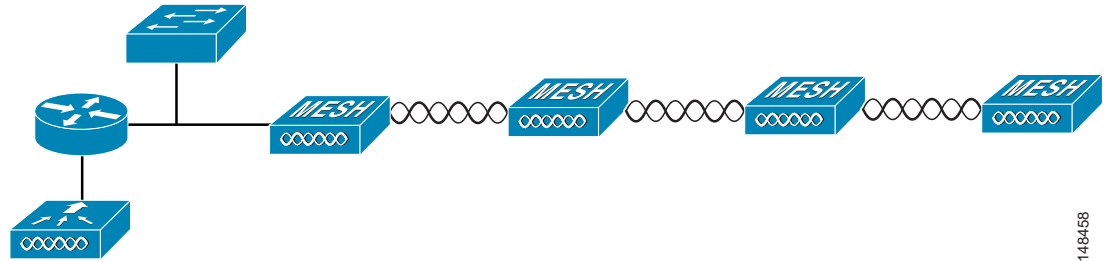

148458



Installing the Access Point

This chapter describes how to install the 1532 access point and contains the following sections:

- [Unpacking the Access Point, page 2-2](#)
- [Tools and Hardware, page 2-2](#)
- [Warnings, page 2-3](#)
- [Safety Information, page 2-4](#)
- [Avoiding Damage to Radios in a Testing Environment, page 2-6](#)
- [Installation Guidelines, page 2-6](#)
- [Mounting the Access Point, page 2-11](#)
- [Installing Antennas, page 2-28](#)
- [Grounding the Access Point, page 2-40](#)
- [Powering the Access Point, page 2-40](#)
- [Configuring the Access Point, page 2-53](#)
- [What to Do Next, page 2-54](#)

Unpacking the Access Point

To unpack the access point, follow these steps:

-
- Step 1** Open the shipping container and carefully remove the contents.
 - Step 2** Return all packing materials to the shipping container, and save it.
 - Step 3** Ensure that all items listed in [“Package Contents”](#) are included in the shipment. If any item is damaged or missing, notify your authorized Cisco sales representative.
-

Package Contents

Each access point package contains the following items:

- One 1530 series access point
- Two-pin DC power connector
- Ground lug and screws with lock washers
- Plastic cable gland and rubber seal
- Weatherization tape and anti-corrosion sealant
- Cisco product documentation and pointer card

Tools and Hardware

The tools and hardware used to install the 1532 access point are described in:

- [Optional Tools and Hardware, page 2-2](#)
- [Optional Tools and Hardware That You Supply, page 2-3](#)
- [Warnings, page 2-3](#)
- [Warnings, page 2-3](#)

Optional Tools and Hardware

Depending on what you ordered, the following optional equipment may be part of your shipment:

- External antennas, depending on which ones you purchased (see [“Antenna Configurations” section on page 2-29](#) for more information).
- Wall/Pole mount bracket, available as an option or a spare (AIR-ACC1530-PMK1[=])
- Wall/Pole mount bracket with tilt mechanism, spare only (AIR-ACC1530-PMK2=)
- AP cover / Solar Shield for 1532, spare only (AIR-ACC1530-CVR=)
- AC/DC power adapter, spare only (AIR-PWRADPT-1530=)
- Spare Parts kit containing extra cable glands, power connector, ground lug, etc. (AIR-ACC1530-KIT1=)

- FIPS kit (AIRLAP-FIPSKIT=)
- Lightning Arrestor kit (AIR-ACC245LA-N=)

Optional Tools and Hardware That You Supply

Tools and materials that are user-supplied are:

- Ground lug crimping tool (Panduit CT-720 with CD-720-1 die)
- 6-AWG copper ground wire
- 10 mm open end or box wrench
- 13 mm box-end wrench or socket set
- Adjustable wrench with opening up to 33 mm and 28 mm socket.
- Large flat or Phillips screw driver (for port plugs)
- Small flat screwdriver for DC power connector
- Optional shielded outdoor-rated Ethernet (CAT5e or better) cable with 0.20 to 0.35 in (0.51 to 0.89 cm) diameter
- Optional Ethernet RJ-45 connector and installation tool
- Optional shielded outdoor-rated DC power cable with 0.20 to 0.35 inch (.051 to 0.89 cm) diameter
- Optional ground rod, as required by local regulations
- Optional ladder, power lift, rope, or other tools as required

Warnings

Translated versions of all safety warnings are available in the safety warning document that shipped with your access point or on Cisco.com. To browse to the document on Cisco.com, refer to [Appendix A](#), “Translated Safety Warnings” for instructions.



Warning

IMPORTANT SAFETY INSTRUCTIONS

This warning symbol means danger. You are in a situation that could cause bodily injury. Before you work on any equipment, be aware of the hazards involved with electrical circuitry and be familiar with standard practices for preventing accidents. Use the statement number provided at the end of each warning to locate its translation in the translated safety warnings that accompanied this device. Statement 1071

SAVE THESE INSTRUCTIONS



Warning

This equipment is to be installed by trained and qualified personnel, as per these installation instructions. The installer is responsible for obtaining any required local or national safety inspections of the structural integrity of the installation by the local authority/inspection department.



Warning

Do not operate the unit near unshielded blasting caps or in an explosive environment unless the device has been modified to be especially qualified for such use. Statement 364

**Warning**

The cables specified in this installation guide that are used with the specified cable glands provide protection against ingress of moisture for a Type 4/IP67 classified enclosure. If substitute cable are used, the installer must ensure that the size (OD) of the cable meets the acceptable range allowed by the cable gland.

**Warning**

This equipment must be externally grounded using a customer-supplied ground wire before power is applied. Contact the appropriate electrical inspection authority or an electrician if you are uncertain that suitable grounding is available. Statement 366

**Warning**

Read the installation instructions before connecting the system to the power source. Statement 1004

**Warning**

Ultimate disposal of this product should be handled according to all national laws and regulations. Statement 1040

Safety Information

Follow the guidelines in this section to ensure proper operation and safe use of the access point.

FCC Safety Compliance Statement

The FCC, with its action in ET Docket 96-8, has adopted a safety standard for human exposure to RF electromagnetic energy emitted by FCC-certified equipment. When used with approved Cisco Aironet antennas, Cisco Aironet products meet the uncontrolled environmental limits found in OET-65 and ANSI C95.1, 1991. Proper operation of this radio device according to the instructions in this publication results in user exposure substantially below the FCC recommended limits.

Safety Precautions

**Warning**

In order to comply with radio frequency (RF) exposure limits, the antennas should be placed no less than 20 cm (8") from your body or nearby persons. Statement 339

**Warning**

Do not work on the system or connect or disconnect cables during periods of lightning activity. Statement 1001

**Warning**

A readily accessible two-poled disconnect device must be incorporated in the fixed wiring. Statement 1022



Warning To reduce the risk of fire, use only No. 26 AWG or larger telecommunication line cord. Statement 1023



Warning This unit might have more than one power supply connection. All connections must be removed to de-energize the unit. Statement 1028



Warning Only trained and qualified personnel should be allowed to install, replace, or service this equipment. Statement 1030



Warning Connect the unit only to DC power source that complies with the safety extra-low voltage (SELV) requirements in IEC 60950 based safety standards. Statement 1033



Warning When installing or replacing the unit, the ground connection must always be made first and disconnected last. Statement 1046.



Warning Do not locate the antenna near overhead power lines or other electric light or power circuits, or where it can come into contact with such circuits. When installing the antenna, take extreme care not to come into contact with such circuits, because they may cause serious injury or death. For proper installation and grounding of the antenna, please refer to national and local codes (for example, U.S.:NFPA 70, National Electrical Code, Article 810, Canada: Canadian Electrical Code, Section 54). Statement 1052



Caution Before connecting or disconnecting a power cord, you must remove power from the power cord using a suitable service disconnect.

For safety and to achieve a good installation, please read and follow these safety precautions:

- Select your installation site with safety, as well as performance in mind. Remember: electric power lines and phone lines look alike. For safety, assume that any overhead line can kill.
- Call your electric power company. Tell them your plans, and ask them to come look at your proposed installation.
- Plan your installation carefully and completely before you begin. Successful raising of a mast or tower is largely a matter of coordination. Each person should be assigned to a specific task and should know what to do and when to do it. One person should be in charge of the operation to issue instructions and watch for signs of trouble.
- When installing the access point and antennas, remember:
 - Do not use a metal ladder.
 - Do not work on a wet or windy day.
 - Do dress properly—shoes with rubber soles and heels, rubber gloves, long sleeved shirt or jacket.

- Use a rope to lift the access point. If the assembly starts to drop, get away from it and let it fall.
- If any part of the antenna system should come in contact with a power line, do not touch it or try to remove it yourself. Call your local power company. They will remove it safely.

If an accident should occur, call for qualified emergency help immediately.

Avoiding Damage to Radios in a Testing Environment

The radios on outdoor units (bridges) have higher transmit power levels than radios on indoor units (access points). When you test high-power radios in a link, you must avoid exceeding the maximum receive input level for the receiver. At levels above the normal operating range, packet error rate (PER) performance is degraded. At even higher levels, the receiver can be permanently damaged. To avoid receiver damage and PER degradation, you can use one of the following techniques:

- Separate the omnidirectional antennas by at least 2 ft (0.6 m) to avoid receiver damage or by at least 25 ft (7.6 m) to avoid PER degradation.



Note These distances assume free space path loss and are conservative estimates. Required separation distances for damage and performance degradation levels in actual deployments are less if conditions are not non-line-of-sight.

- Reduce the configured transmit power to the minimum level.
- Use directional antennas, and keep them away from each other.
- Cable the radios together using a combination of attenuators, combiners, or splitters to achieve a total attenuation of at least 60 dB.

For a radiated test bed, the following equation describes the relationships among transmit power, antenna gain, attenuation, and receiver sensitivity:

$$\text{txpwr} + \text{tx gain} + \text{rx gain} - [\text{attenuation due to antenna spacing}] < \text{max rx input level}$$

Where:

txpwr = Radio transmit power level

tx gain = transmitter antenna gain

rx gain = receiver antenna gain

For a conducted test bed, the following equation describes the relationships among transmit power, antenna gain, and receiver sensitivity:

$$\text{txpwr} - [\text{attenuation due to coaxial components}] < \text{max rx input level}$$



Caution

Under no circumstances should you connect the antenna port from one access point to the antenna port of another access point without using an RF attenuator. If you connect antenna ports, you must not exceed the maximum survivable receive level of 0 dBm. Never exceed 0 dBm, or damage to the access point can occur. Using attenuators, combiners, and splitters having a total of at least 60 dB of attenuation ensures that the receiver is not damaged and that PER performance is not degraded.

Installation Guidelines

Because the access point is a radio device, it is susceptible to common causes of interference that can reduce throughput and range. Follow these basic guidelines to ensure the best possible performance:

- For information on planning and initially configuring your Cisco Mesh network, refer to the *Cisco Wireless Access Points, Design and Deployment Guide, Release 7.3*.
- Review the FCC guidelines for installing and operating outdoor wireless LAN devices at http://www.cisco.com/c/en/us/products/collateral/routers/3200-series-rugged-integrated-services-routers-isr/data_sheet_c78-647116.html.
- Perform a site survey before beginning the installation.
- Install the access point in an area where structures, trees, or hills do not obstruct radio signals to and from the access point.
- The access points can be installed at any height, but best throughput is achieved when all the access points are mounted at the same height. We recommend installing the access points no higher than 40 feet to allow support for wireless clients on the ground.
- The Console-Reset port and the Reset button are under a hex-shaped sealed plug. Inspect the seal of the plug and properly tighten it at the time of installation, and also every time the plug is removed and replaced. Tighten the plug to 15 lbf-in. If you do not tighten the plug properly, it will not meet IP67 criteria, and may lead to water leaking into the unit.
- If the DC power port, LAN port, or the PoE-In port is not in use, then the port's covering plug must be tightened to 12.5 lbf-in torque. Otherwise, it may lead to water leaking into the access point.

**Note**

To calculate path loss and to determine how far apart to install access points, consult an RF planning expert.

Site Surveys

Every network application is a unique installation. Before installing multiple access points, you should perform a site survey to determine the optimum use of networking components and to maximize range, coverage, and network performance.

Site surveys reveals problems that can be resolved before the network is operational. Because 802.11a/b/g/n operates in an unlicensed spectrum, there may be sources of interference from other 802.11a wireless devices (especially in multi-tenant buildings) that could degrade your 802.11 signals. A site survey can determine if such interference exists at the time of deployment.

A proper site survey involves temporarily setting up mesh links and taking measurements to determine whether your antenna calculations are accurate. Determine the correct locations and antenna types before you drill holes and route cables and mounting equipment.

Consider the following operating and environmental conditions when performing a site survey:

- Data rates—Sensitivity and range are inversely proportional to data bit rates. The maximum radio range is achieved at the lowest workable data rate. A decrease in receiver sensitivity occurs as the radio data increases.
- Antenna type and placement—Proper antenna configuration is a critical factor in maximizing radio range. As a general rule, range increases in proportion to antenna height. However, do not place the antenna higher than necessary, because the extra height also increases potential interference from other unlicensed radio systems and decreases the wireless coverage from the ground.
- Physical environment—Clear or open areas provide better radio range than closed or filled areas.
- Obstructions—Physical obstructions such as buildings, trees, or hills can hinder performance of wireless devices. Avoid locating the devices in a location where there is an obstruction between the sending and receiving antennas.

- How far is your wireless link?
- Has a previous site survey been conducted?
- Do you have a clear Fresnel zone between the access points or radio line of sight?
- What is the minimum acceptable data rate within the link?
- Do you have the correct antenna (if more than one antenna is being offered?)
- Do you have access to both of the mesh site locations?
- Do you have the proper permits, if required?
- Are you following the proper safety procedures and practices?
- Have you configured the access points before you go onsite? It is always easier to resolve configurations or device problems first.
- Do you have the proper tools and equipment to complete your survey.

Before Beginning the Installation

Before you begin the installation process:

- Ensure that a site survey has been performed.
- Ensure that your network infrastructure devices are operational and properly configured.
- Ensure that your controllers are connected to switch trunk ports.
- Ensure that your switch is configured with untagged access ports for connecting your access points.
- Ensure that a DHCP server with Option 43 configured is reachable by your access points, or manually configure the controller information in the access point (for additional information, refer to the [“Configuring DHCP Option 43”](#) section on page F-1).
- Become familiar with the access point installation components (see the [“Becoming Familiar with Access Point Installation Components”](#) section on page 2-8).

Becoming Familiar with Access Point Installation Components

The access point is designed to be installed in an outdoor environment, such as the exterior roof overhang of a tall building or a streetlight pole. Carefully review the following figures to become familiar with the system components, connectors, indicators, cables, system interconnection, and grounding:

- Components in a typical access point installation (see [Figure 2-1](#))
- Pole mount installation (see [Figure 2-2](#))
- Streetlight power tap installation, works only with the AC/DC power adapter (see [Figure 2-3](#)). For information on how to connect to Streetlight AC power, see [Connecting Streetlight AC Power](#). Note that this type of deployment requires an alternate AP mounting kit. See [Mounting the Access Point](#) section for more information.



Note

The illustrations in this document show all available connections for the access point. Unused connections are capped with a connector plug to ensure the watertight integrity of the access point. Cable glands are provided for connector openings, which can be installed before or after deploying the access point.

Figure 2-1 Components in a Typical Access Point Installation

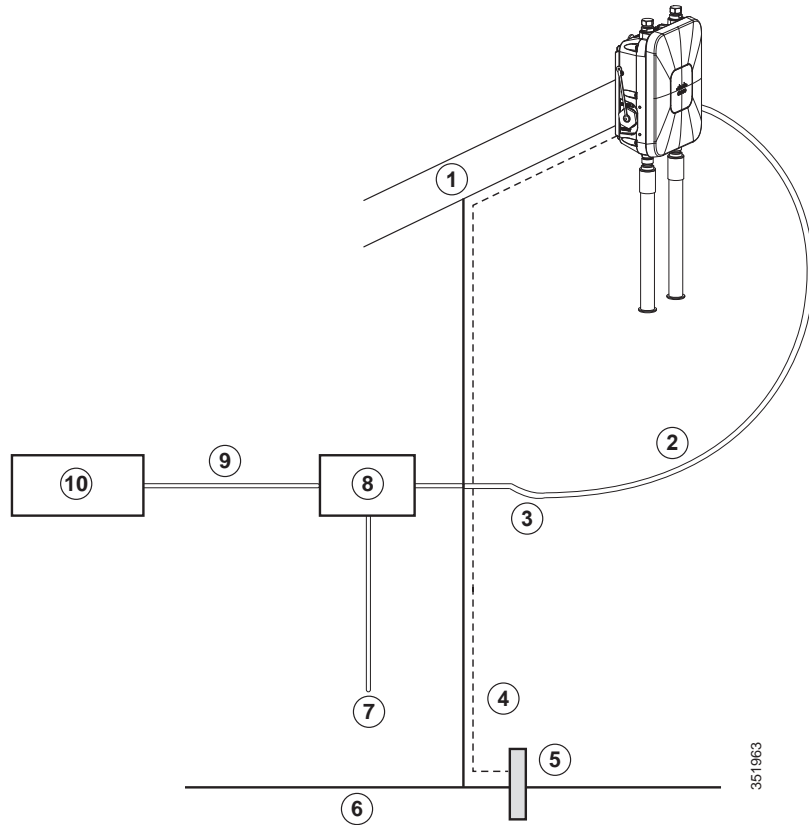

1	Building roof-overhang	6	Ground
2	Shielded outdoor-rated Ethernet (CAT5e or better) cable ¹	7	Power cord
3	Water drip loop	8	Power injector
4	6-AWG copper grounding wire ¹	9	Shielded Ethernet (CAT5e or better) cable ¹
5	Ground rod ¹	10	Controller (through a switch)

1. User supplied.



Warning

Installation of the equipment must comply with local and national electrical codes. Statement 1074

Figure 2-2 Standard Pole Mount Installation

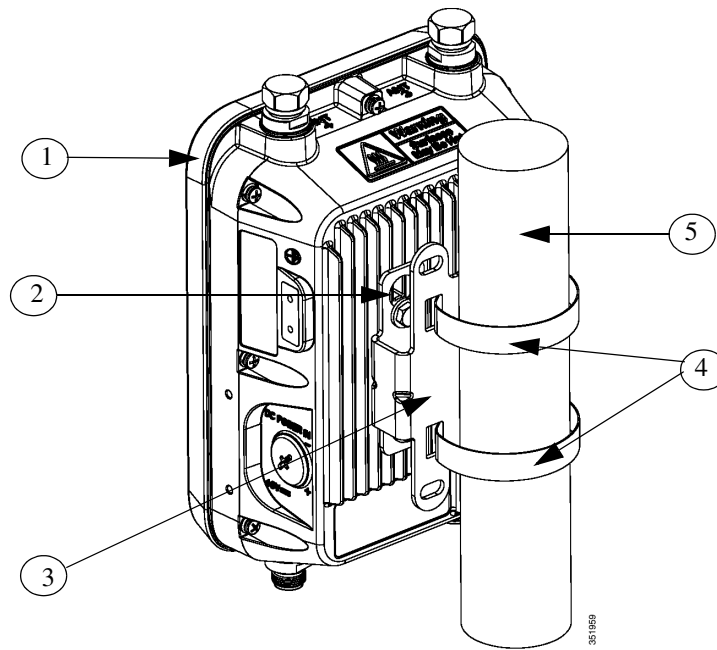

1	1532 series access point model AIR-CAP1532E-x-K9	3	Mounting bracket (part of pole mount kit)
2	One of four M6 AP mount hole and key hole slots	4	Stainless steel mounting straps (part of pole mount kit)
5	Pole (wood, metal, or fiberglass) 2 in. to 8 in. (50 mm to 203 mm) diameter		

Figure 2-3 Streetlight Power Tap Adapter Installation

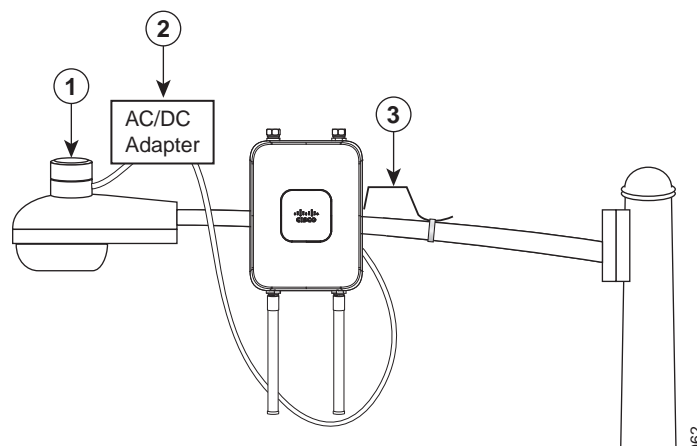

1	Outdoor light control	3	6-AWG copper grounding wire
2	AC/DC power adapter		

Mounting the Access Point

This section provides instructions for installing your access points. Personnel installing the access point must understand wireless access points and bridging techniques and grounding methods.



Caution

All installation methods for mounting an access point on any wall surface is subject to the acceptance of local jurisdiction.

Installation Options

The 1530 Series Access Point can be wall, pole or tower mounted. There are two optional mounting kits: a fixed mounting kit (AIR-ACC1530-PMK1=) and a pivoting mounting kit (AIR-ACC1530-PMK2=).



Warning

Only trained and qualified personnel should be allowed to install, replace, or service this equipment. Statement 1030



Warning

Installation of the equipment must comply with local and national electrical codes. Statement 1074

Access Point Mounting Orientation

When mounting an access point on a horizontal or vertical surface, you must ensure that the access point is oriented with the LED indicators pointing down. This positioning allows LEDs to be visible to someone on the ground below the access point.

You must also ensure the access point is mounted in such a way as to ensure that all antenna ports and the console port are accessible for future use.



Note

Omnidirectional antennas are vertically polarized and should be mounted vertically.

Wall Mounting the Access Point with the Fixed Mounting Kit

The optional fixed mounting kit contains a mounting bracket for wall mounting or pole mounting. You can use the mounting bracket as a template to mark the positions of the mounting holes for your installation. You then install the mounting plate, and attach the access point when you are ready. [Table 2-1](#) lists the materials you will need to provide in addition to the fixed mounting kit.

Table 2-1 Materials Required to Mount Access Point to a Vertical Wall

Materials Required to Mount Access Point to a Vertical Wall	In Kit
Ground lug and screws (provided with access point)	Yes
Wall Mount Bracket	Yes
Four M6 x 12-mm Hex-head Bolts	Yes

Materials Required to Mount Access Point to a Vertical Wall	In Kit
Two stainless steel band clamps (adjustable 2"–5", 51 mm – 127 mm)	Yes
Two stainless steel band clamps(adjustable 5"–8", 127 mm – 203 mm)	Yes
Crimping tool for ground lug, Panduit CT-720 with CD-720-1 die (http://www.panduit.com)	No
Four wall mounting screws	No
Four wall anchors (specified for all material)	No
Drill bit for wall anchors	No
Electric drill and standard screwdriver	No
#6 AWG ground wire	No
Shielded outdoor-rated Ethernet (CAT5e or better) cable	No
Grounding block	No
Grounding rod	No
10-mm box-end wrench or socket set	No



Caution The mounting surface, attaching screws and optional wall anchors must be able to support a 50-lb (22.7 kg) static weight.

To mount the access point on a vertical wall, follow these instructions:

- Step 1** Use the mounting bracket as a template to mark four screw hole locations on the mounting surface. See [Figure 2-4](#) for the mounting bracket screw hole locations. Use the mounting slotted holes to attach the unit to the wall.

Figure 2-4 Mounting Bracket for Wall and Pole Mounting

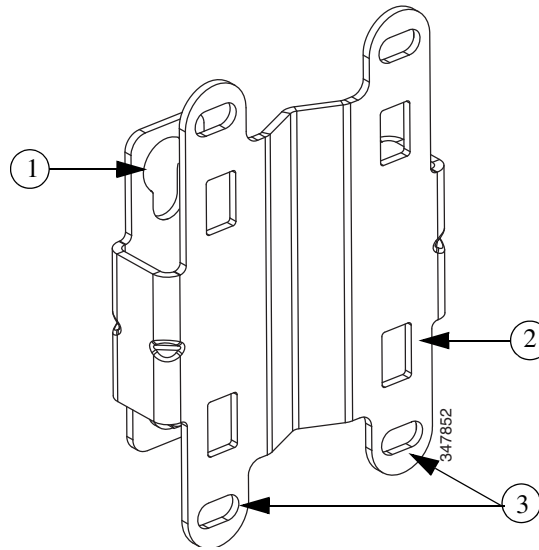

1	Quick Mount Keyhole Slots (for AP use)	2	Mounting Slots (used with the band clamps)
3	Bracket Mount Holes (use bolts up to 1/4" or 6 mm in diameter)		

Step 2 Use four customer-supplied screws and optional screw-anchors to attach the mounting plate to the mounting surface.



Note If necessary, use suitable screw anchors and an exterior-grade plywood backboard to mount the access point to stucco, cement or drywall.

Figure 2-5 Mounting Bracket Dimensions

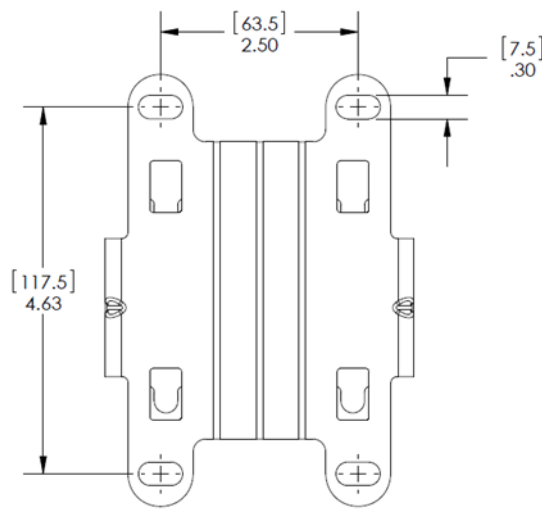

- Step 3** Screw an M6 x12 mm bolt into each of the four support bolt holes on the back of the access point. Do not screw the bolt all the way in; leave approximately a 0.13 inch (3.3 mm) space.
- Step 4** Position the four bolts on the access point into the keyhole slots on the mounting bracket.
- Step 5** Slide the access point down to sit securely in the quick mount notches.
- Step 6** Using a 10mm wrench, secure the AP to the bracket by tightening the bolts to the bracket; torque to 40 lb-in.
- Step 7** Continue with the [Grounding the Access Point, page 2-40](#).

Pole Mounting the Access Point with the Fixed Mount Kit

The optional fixed mounting kit contains a mounting bracket for wall mounting or pole mounting. This kit can be used to install the access point on a pole, mast or streetlight. It supports metal, wood or fiberglass poles from 2 to 8 inches in diameter.

Table 2-2 Materials Needed to Mount the AP on a Vertical Pole

Materials Needed to Mount the AP on a Vertical Pole	In Kit
One wall mount bracket	Yes
Four M6 x12mm hex head bolts	Yes
Two stainless steel band clamps (adjustable 2"–5", 51–127 mm)	Yes
Two stainless steel band clamps (adjustable 5"–8", 127–203 mm)	Yes
10 mm box-end wrench	No
Outdoor rated shielded ethernet cable	No
Ground lug (provided with the access point)	Yes
Ground block and rod	No
Crimping tool for ground lug, Panduit CT-720 with CD-720-1 die (http://www.panduit.com)	No
#6 AWG ground wire	No

To mount the access point onto a vertical pole or streetlight pole, follow these steps:

- Step 1** Select a mounting location on the pole to mount the access point. You can attach the access point to any pole with a diameter from 2 to 8 inches (5.1 to 20.1 cm).



Note If you will be using a streetlight power tap adapter, position the access point within 3 ft (1 m) of the outdoor light control. The AC/DC adapter must be used with street light power tap.

- Step 2** Determine which size of band clamp is needed based on the pole diameter. Slide the two clamps through the top and bottom set of mounting slots (see [Figure 2-4](#)) and mount the bracket to the pole.
- Step 3** Wrap the band clamps around the pole and slide them into the second set of top and bottom mounting slots on the bracket. Lightly tighten the clamps. Only tighten them enough to keep the bracket from sliding down the pole.

- Step 4** Screw an M6 bolt into each of the four bolt holes on the back side of the access point. Do not screw the bolt in all the way. Leave a gap of about 0.13" (3.3mm).
- Step 5** Position the four bolts on the access point into the bracket keyhole slots. Check to be sure that the access point is properly seated in the slots.(See [Figure 2-6](#))



Note The access point should be positioned with the LEDs on the bottom to allow viewing from the ground.

- Step 6** Using a 10mm wrench, tighten the four bolts that connect the access point to the bracket to a torque of 40 lbf-in.
- Step 7** Locate the access point to its final position. Tighten the band clamps with the wrench so that the access point does not slide on the pole. Ensure that the clamps are tight enough to not let the AP move.
- Step 8** Continue with the [Grounding the Access Point, page 2-40](#).

Figure 2-6 AP and Fixed Mount Kit Installed on a Pole

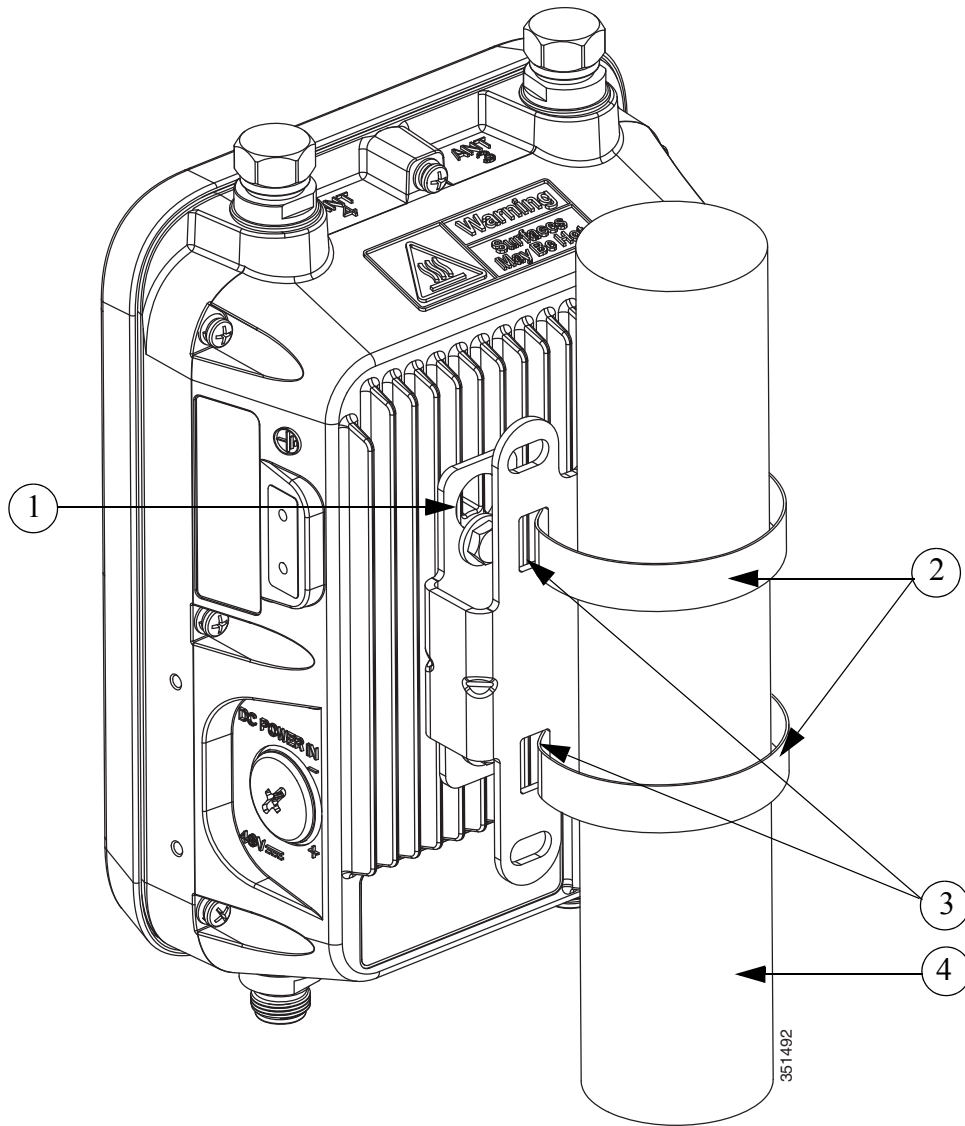

1	One of four M6 AP mount hole and key hole slots	2	Metal Band Straps
3	Mounting Slots	4	Pole

Wall Mounting the Access Point with the Pivoting Mounting Kit

The optional pivoting mounting kit contains a mounting bracket for wall or pole mounting. This kit can be used to install the access point on a wall while still allowing for some freedom of movement. This bracket supports metal, wood or fiberglass surfaces.

Figure 2-7 Pivoting Mounting Kit

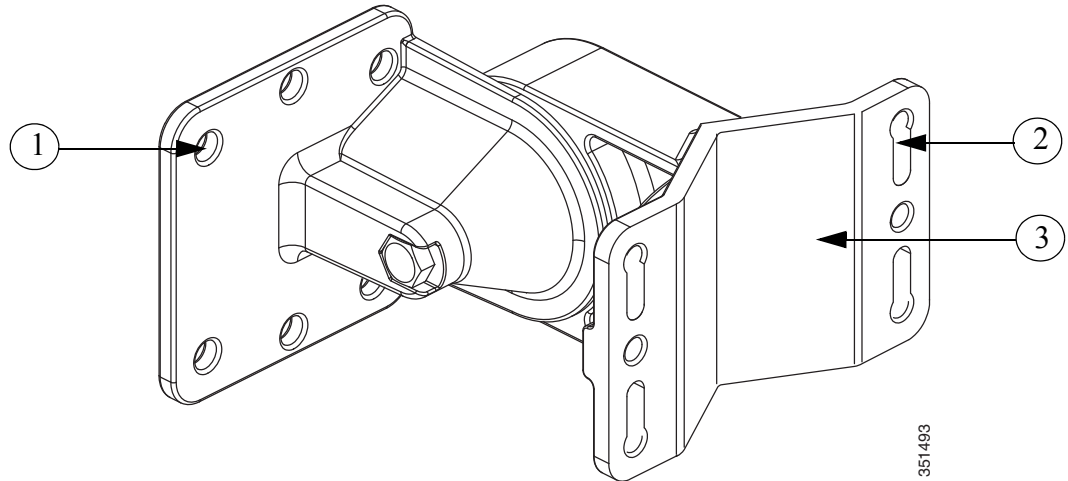

1	Mounting holes for the AP	2	Slots for wall-mounting and band clamps.
3	Wall mount bracket.		

Figure 2-8 Pivoting Mounting Kit Dimensions

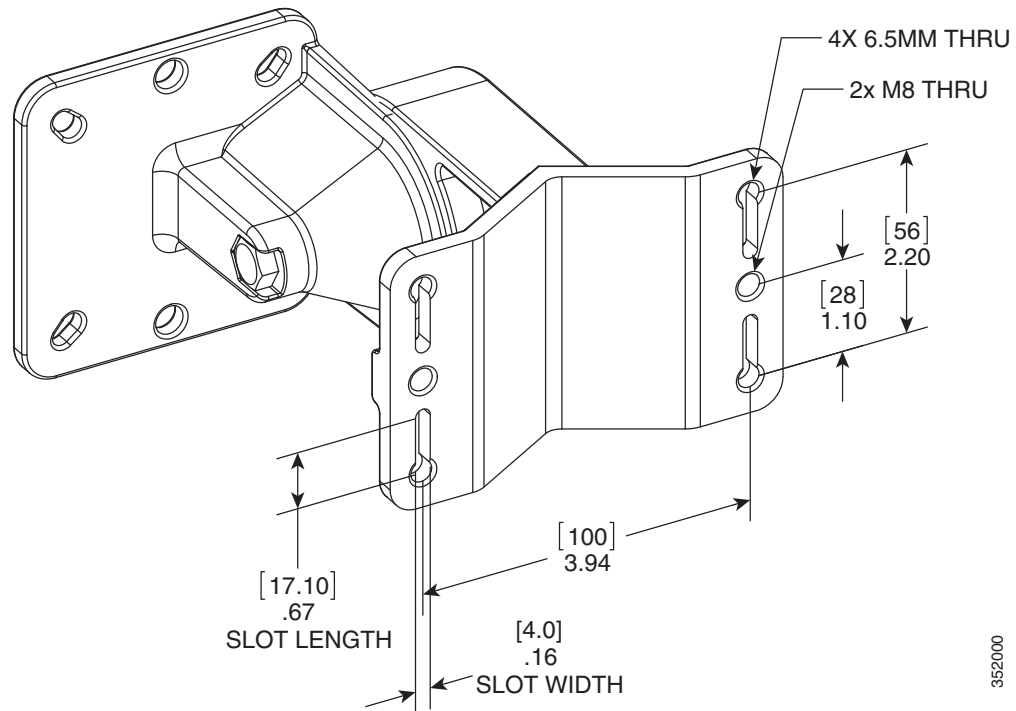

352000

Table 2-3 Materials for Mounting on Wall with Pivoting Mounting Kit

Materials Required for mounting AP on a vertical wall with pivoting mounting kit	In Kit
Ground lug and screws (provided with access point)	Yes
Pivoting mount kit and hardware	Yes
(8) M6 x 12-mm Hex-head Bolts	Yes
Adapter bracket for option horizontal mount	Yes
Two stainless steel band clamps (adjustable 2"-5", 51 mm - 127 mm)	Yes
Two stainless steel band clamps (adjustable 5"-8", 127 mm - 203 mm)	Yes
Crimping tool for ground lug, Panduit CT-720 with CD-720-1 die (http://www.panduit.com)	No
Four wall mounting screws (6mm max)	No
Four wall anchors (specified for all material)	No
Drill bit for wall anchors	No
Electric drill and standard screwdriver	No
#6 AWG ground wire	No
Shielded outdoor-rated Ethernet (CAT5e or better) cable	No
Grounding block	No
Grounding rod	No

Materials Required for mounting AP on a vertical wall with pivoting mounting kit	In Kit
13-mm box-end wrench or socket set	No
10-mm box-end wrench	No

Figure 2-9 AP wall mounted with Pivoting Mounting Kit

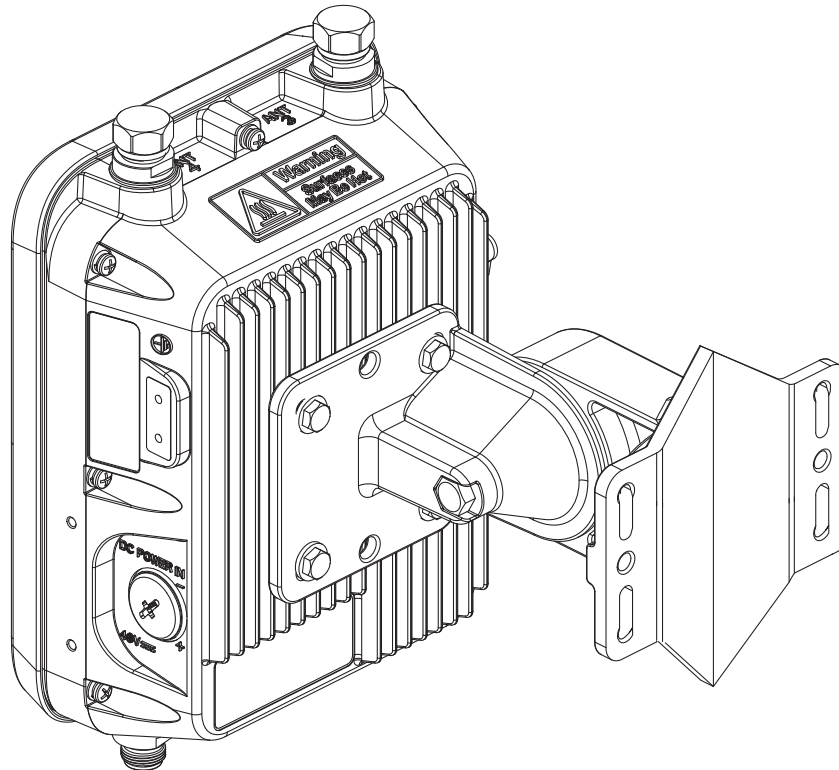

Caution

The mounting surface, attaching screws and optional wall anchors must be able to support a 50-lb (22.7 kg) static weight.

To mount the access point on a vertical wall, follow these instructions:

- Step 1** Disassemble pivot kit, if not already done.
- Step 2** Use the mounting bracket as a template to mark four screw hole locations on the mounting surface. See [Figure 2-7](#) for the mounting bracket screw hole locations (screw holes of maximum 6 mm in size).
- Step 3** Use four customer-supplied screws and optional screw-anchors to attach the mounting plate to the mounting surface.



Note

If necessary, use suitable screw anchors and an exterior-grade plywood backboard to mount the access point to stucco, cement or drywall.

- Step 4** Match the holes in the bracket plate to the holes in the back of the access point.
- Step 5** Screw an M8 x12 mm bolt into each of the four bolt holes (using a 10 mm box wrench or socket, torque the bolts to 40 lbf-in) on the back side of the access point and mounting bracket.

- Step 6** Using the long bolt and the hardware supplied with the pivoting bracket, bolt the AP and its mounted bracket, on to the bracket mounted on the wall (see [Figure 2-11](#) for an exploded view of this assembly).
- Step 7** Pivot the AP to your desired position, and then tighten the bolts (using a 13 mm wrench).
- Step 8** Continue with [Grounding the Access Point, page 2-40](#).

Pole Mounting the Access Point with the Pivoting Mounting Kit

The optional pivoting mounting kit contains a mounting bracket for wall mounting or pole mounting, along with a clamp for pole mounting. This kit can be used to install the access point on a pole, mast or streetlight. It supports metal, wood or fiberglass poles from 2 to 8 inches in diameter.

Figure 2-10 Pivoting Mounting Kit with Pole Mount Clamp

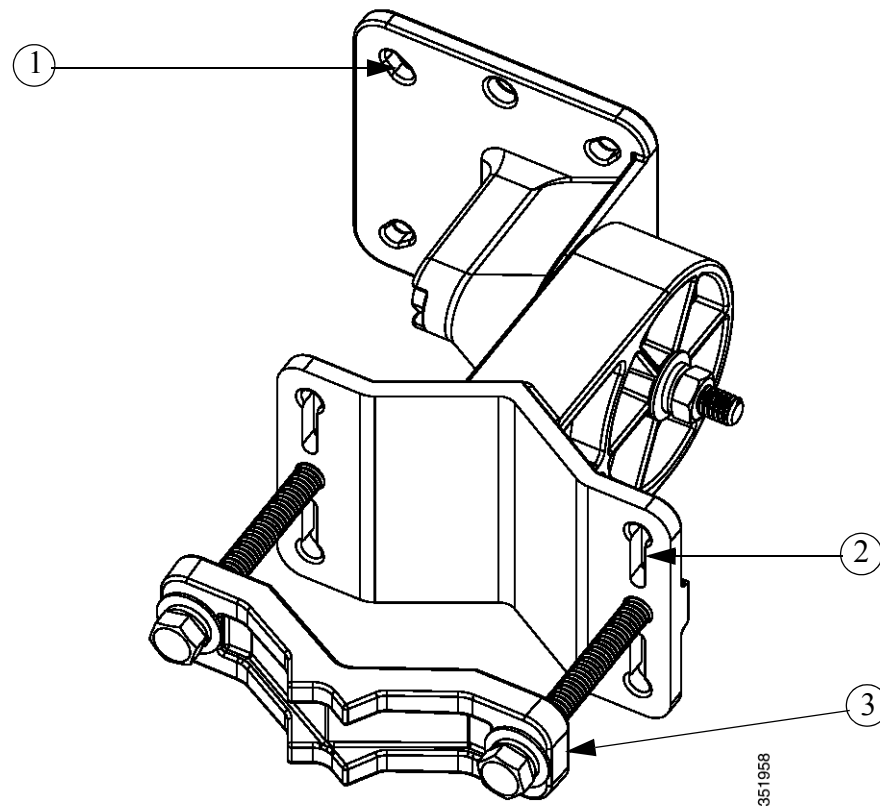

1	Mounting holes for the access point	2	Slots for band clamps (band clamps are provided but not shown in this figure. See Figure 2-12).
3	Pole mount clamp. It can fit poles of range up to 3 in. (76mm)		

Figure 2-11 Exploded View of the Pivoting Mounting Kit

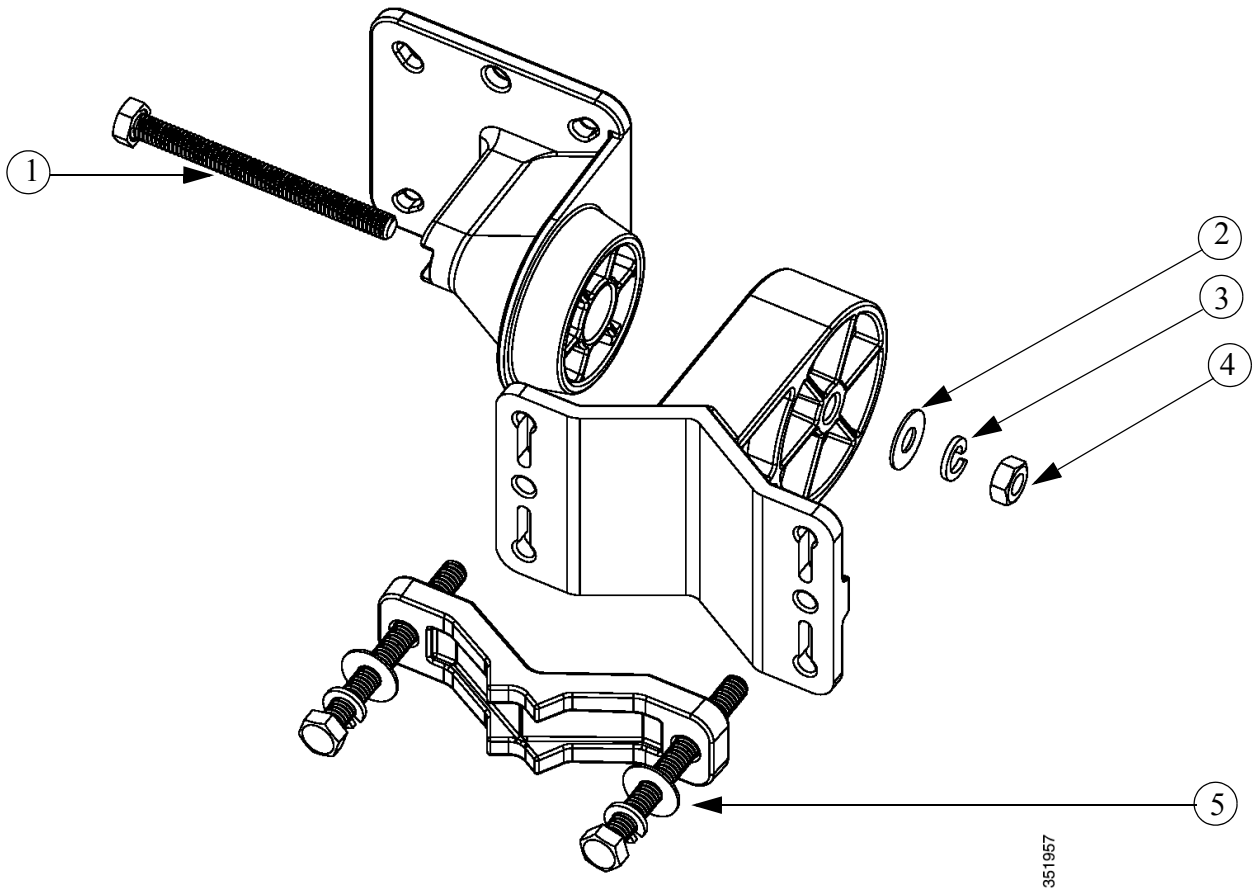

1	90.0 mm M8 screw	2	M8 washer
3	M8 spring washer	4	M8 nut
5	80.0 mm M8 screw with washer and spring washer		

Table 2-4 Materials Needed to Mount the AP on a Vertical Pole with the Pivoting Mounting Kit

Materials Required	In Kit
Ground lug and screws (provided with access point)	Yes
Pivoting mount kit and hardware	Yes
(8) M6 x 12-mm Hex-head Bolts	Yes
Adapter bracket for option horizontal mount	Yes
Two stainless steel band clamps (adjustable 2"-5", 51 mm - 127 mm)	Yes
Two stainless steel band clamps (adjustable 5"-8", 127 mm - 203 mm)	Yes

Materials Required	In Kit
Crimping tool for ground lug, Panduit CT0720 with CD-720-1 die (http://www.panduit.com)	No
Four wall mounting screws (6mm max)	No
Four wall anchors (specified for all material)	No
Drill bit for wall anchors	No
Electric drill and standard screwdriver	No
#6 AWG ground wire	No
Shielded outdoor-rated Ethernet (CAT5e or better) cable	No
Grounding block	No
Grounding rod	No
13-mm box-end wrench or socket set	No
10-mm box-end wrench	No

To mount the access point onto a vertical pole or streetlight pole, follow these steps:

- Step 1** Select a mounting location on the pole to mount the access point. You can attach the access point to any pole with a diameter from 2 to 8 inches (5.1 to 40.6 cm).



Note If you will be using a streetlight power tap adapter, position the access point within 3 ft (1 m) of the outdoor light control.

- Step 2** Mount the pivot bracket base to the pole using either one set of the adjustable band clamps or the screw clamp (the screw clamp can be used on a pole that is not more than 3 inches in diameter).

- Step 3** Position the pole clamp bracket on the pole as needed before tightening the metal bands. Tighten the metal bands only enough to hold the bracket base in place, from sliding along the pole. Fully tighten the bands only after the access point is positioned.

- Step 4** Match the holes in the bracket plate to the holes in the back of the access point.

- Step 5** Screw an M8 x12 mm bolt into each of the four bolt holes (using a 10 mm box wrench or socket, torque the bolts to 40 lbf-in) on the back side of the access point and mounting bracket. (See [Figure 2-11](#))



Note The access point should be positioned with the LEDs on the bottom to allow viewing from the ground.

- Step 6** Mount the bracket with the AP, to the bracket on the pole. Use the long screw for this, as shown in the exploded view – see [Figure 2-11](#).

- Step 7** Point the AP in the general desired position and tighten bolt, and then tighten the clamps on the pole. The AP can be repositioned to its final position by loosening and re-tightening the bolts.

Figure 2-12 AP Pivot Mounted

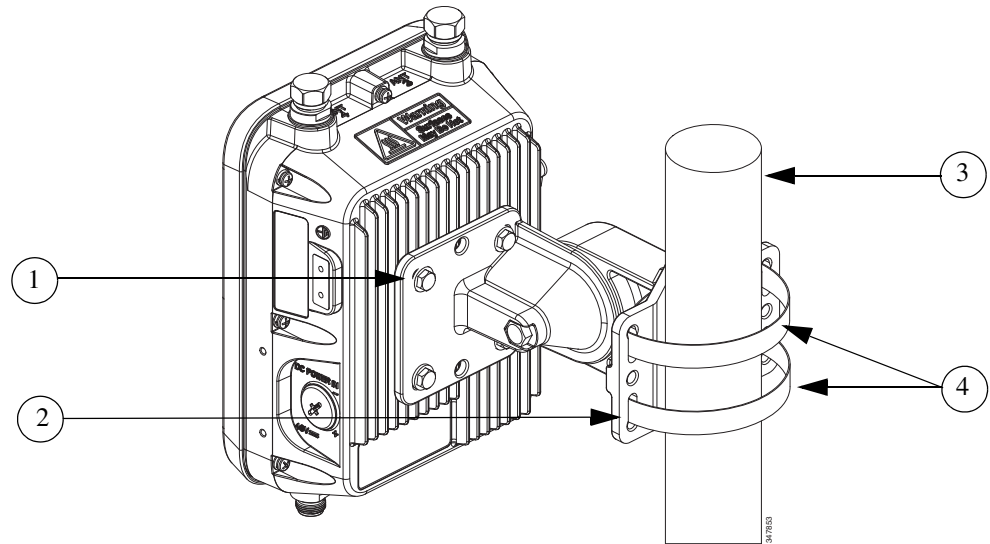

1	Bolted Bracket Mounting Holes	2	Mounting Slots
3	Pole	4	Metal Band Mounting Straps. For the kit which uses a clamp instead of metal bands, see Figure 2-10 .

Step 8 Continue with the [Grounding the Access Point, page 2-40](#)

Horizontally Mounting the Access Point with Optional Horizontal Mount Plate

The pivoting pole mount kit also contains a plate that allows the option of the AP enclosure to be mounted horizontally (See [Figure 2-13](#)).

Table 2-5 Materials Needed to Mount the AP on a Vertical Pole with the Pivoting Mounting Kit

Materials Required	In Kit
Ground lug and screws (provided with access point)	Yes
Pivoting mount kit and hardware	Yes
(8) M6 x 12-mm Hex-head Bolts	Yes
Adapter bracket for option horizontal mount	Yes
Two stainless steel band clamps (adjustable 2"-5", 51 mm - 127 mm)	Yes
Two stainless steel band clamps (adjustable 5"-8", 127 mm - 203 mm)	Yes
Crimping tool for ground lug, Panduit CT0720 with CD-720-1 die (http://www.panduit.com)	No
Four wall mounting screws (6mm max)	No

Materials Required	In Kit
Four wall anchors (specified for all material)	No
Drill bit for wall anchors	No
Electric drill and standard screwdriver	No
#6 AWG ground wire	No
Shielded outdoor-rated Ethernet (CAT5e or better) cable	No
Grounding block	No
Grounding rod	No
13-mm box-end wrench or socket set	No
10-mm box-end wrench	No

-
- Step 1** Mount the pivot bracket to a wall or a pole as shown in the previous procedures.
- Step 2** Using four M6 x 12 mm bolts mount the horizontal adapter plate to the bracket mount plate.
Do not mount the pivot bracket mounting plate directly to the access point.
- Step 3** Using the remaining four M6 x 12 mm bolts, mount the other side of the horizontal mounting plate to the AP. See [Figure 2-14](#) for the exploded view.
- Step 4** Using a 10 mm wrench or socket, tighten all M6 bolts to 40 lbf-in (4.5 Nm).
- Step 5** Position the access point as needed and tighten the mount kit bolts using a 13 mm wrench or socket.
-

Figure 2-13 Access Point Horizontally Mounted using the Optional Horizontal Mount Plate

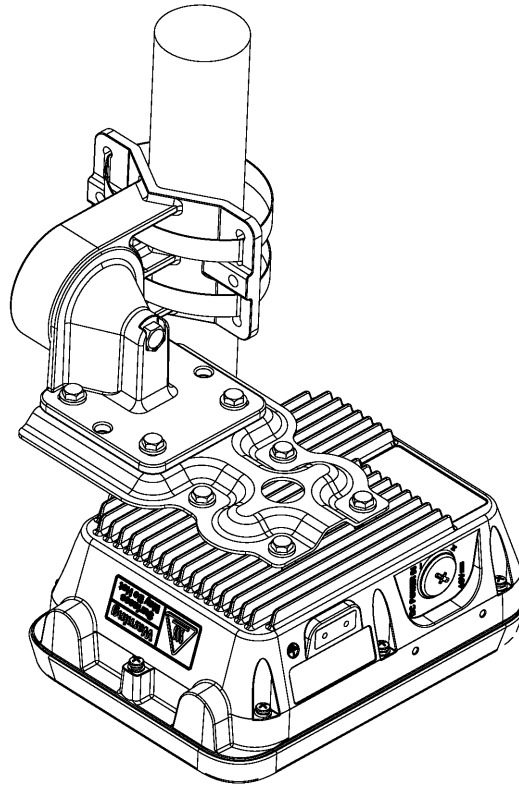
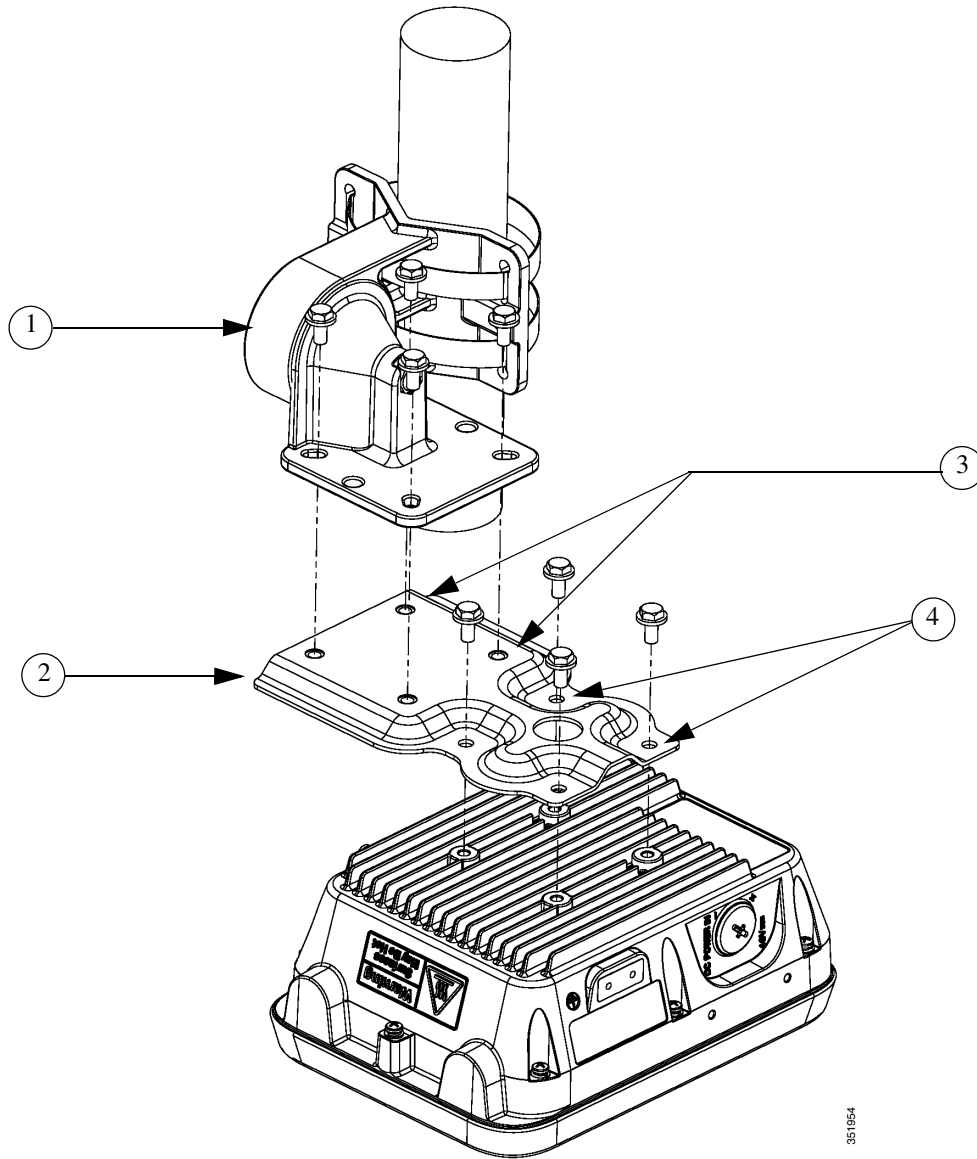

Figure 2-14 Exploded View of a Horizontally Mounted Access Point



1	Pivoting bracket. Can be mounted on a pole or a wall.	2	Horizontal mounting plate
3	Screw holes for mounting the horizontal mounting plate to the pivoting bracket	4	Screw holes for mounting the horizontal mounting plate to the access point

Installing AP Cover or Solar Shield (AIR-ACC1530-CVR=)

You can install an optional solar shield AIR-ACC1530-CVR= to cover the AP.



Note

The cover can be installed prior to or after all connections are made. The only exception is when remote cabled antennas are installed – in such cases, the shield must be installed before the antenna cables are attached to the AP.

Figure 2-15 Installing the Solar Shield

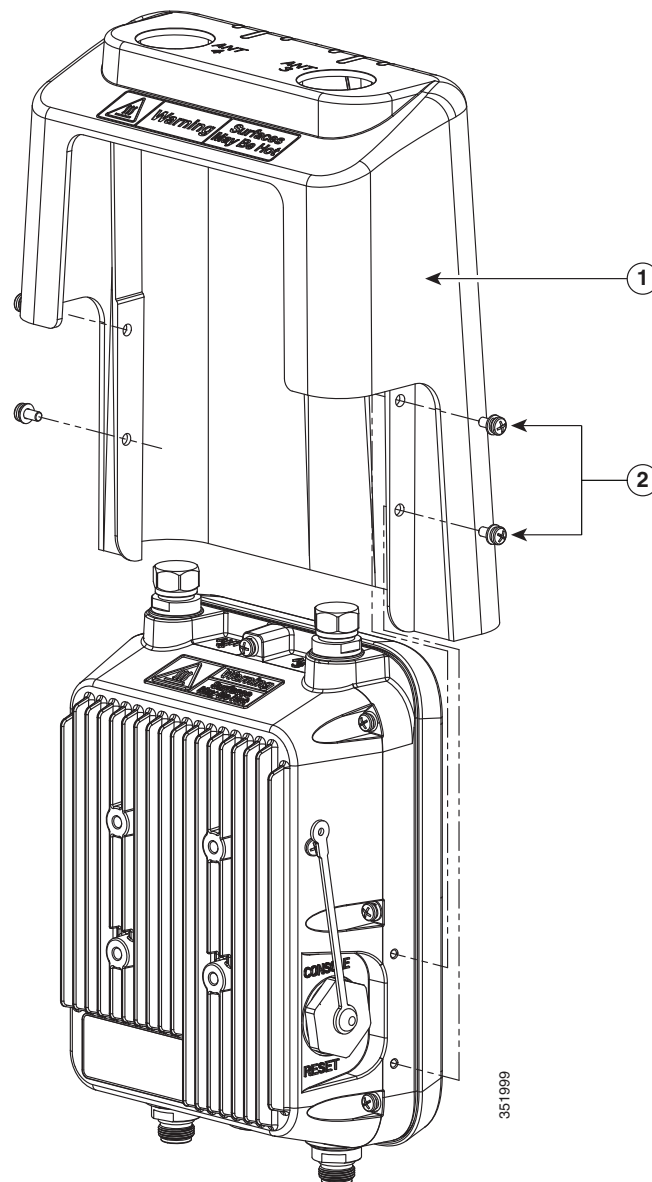

1 Solar Shield	2 Two of four #8-32 screws
----------------	----------------------------

-
- Step 1** Position and slide the cover over the AP as shown in [Figure 2-15](#).
- Step 2** Align the two holes on each side of the cover with the screw holes on corresponding side of the AP.
- Step 3** Insert and install #8-32 screws through the screw holes in the cover and into the AP. Tighten the screws to 10 lb-in.
-

Installing Antennas

[Table 2-6](#) shows the antennas supported by the 1532 access point and provides required quantities for each model.

Table 2-6 1532 Access Point Supported External Antennas

Product ID	Frequency Band	Gain	Type
AIR-ANT2547VG-N	2.4 / 5 GHz	4 / 7 dBi	Omnidirectional (gray)
AIR-ANT2547V-N	2.4 / 5 GHz	4 / 7 dBi	Omnidirectional (white)
AIR-ANT2588P3M-N=	2.4 / 5 GHz	8 / 8 dBi	Directional
AIR-ANT2450V-N	2.4 GHz	5 dBi	Omnidirectional
AIR-ANT2480V-N	2.4 GHz	8 dBi	Omnidirectional
AIR-ANT2413P2M-N=	2.4 GHz	13 dBi	Directional
AIR-ANT5180V-N	5 GHz	8 dBi	Omnidirectional
AIR-ANT5114P2M-N=	5 GHz	14 dBi	Directional

For installation instructions and detailed information on these antennas, refer to the appropriate document located at:

<http://www.cisco.com/c/en/us/support/wireless/aironet-antennas-accessories/products-installation-guides-list.html>

Follow all safety precautions when installing the antennas. For information on safety, refer to “[Safety Precautions when Installing Antennas](#)” section on [page 2-29](#).

Non-Cisco Antennas

Cisco does not support any third-party antennas. RF connectivity and compliance of third party antennas is the customer’s responsibility. Cisco does not recommend any third-party antennas, and Cisco Technical Assistance Center will not be able to provide any support for third-party antennas. Cisco’s FCC Part 15 compliance is only guaranteed with Cisco antennas or antennas that are of the same design and gain as Cisco antennas.

Safety Precautions when Installing Antennas



Do not locate the antenna near overhead power lines or other electric light or power circuits, or where it can come into contact with such circuits. When installing the antenna, take extreme care not to come into contact with such circuits, as they may cause serious injury or death. For proper installation and grounding of the antenna, please refer to national and local codes (e.g. U.S.: NFPA 70, National Electrical Code, Article 810, Canada: Canadian Electrical Code, Section 54). Statement 280

1. Before you install an antenna, contact your Cisco account representative to explain which mounting method to use for the size and type of antenna that you are about to install.
2. Select your installation site with safety, as well as performance, in mind. Remember that electric power lines and phone lines look alike. For your safety, assume that any overhead line can kill you.
3. Contact your electric power company. Tell them your plans and ask them to come look at your proposed installation.
4. Plan your installation carefully and completely before you begin. Each person involved in an installation should be assigned to a specific task and should know what to do and when to do it. One person should be in charge of the operation to issue instructions and watch for signs of trouble.
5. When installing your antenna, follow these guidelines:
 - Do not use a metal ladder.
 - Do not work on a wet or windy day.
 - Do dress properly—wear shoes with rubber soles and heels, rubber gloves, and a long-sleeved shirt or jacket.
6. If the assembly starts to drop, move away from it and let it fall. Because the antenna, mast, cable, and metal guy wires are all excellent conductors of electrical current, even the slightest touch of any of these parts to a power line completes an electrical path through the antenna and the installer.
7. If any part of the antenna system should come in contact with a power line, do not touch it or try to remove it yourself. Call your local power company to have it removed safely.
8. If an accident should occur with the power lines, call for qualified emergency help immediately.

Antenna Configurations

Integrated Antenna Option

The AP1532I uses an Integrated Low Profile Dual-Band 2.4-5 GHz Dipole Antenna Array. The antenna contains an array of three dual-band dipole antennas. The three dipole antennas are contained within this single radome, thereby greatly reducing the antenna's visual footprint, and greatly reducing the possibility of snagging the antenna on the cable bundle, the RF cable, or test cables. Each of these three dipole antennas is a dual-band antenna, covering both the 2.4 - 2.483 GHz band and the 5.25-5.85 GHz bands. The antenna have a peak gain of about 3 dBi at 2.4 GHz and 5 dBi at 5 GHz. The antenna unit is gray weatherproof radome for outdoor operations.

External Antenna Mounting Configurations

The selection of the antenna is determined in the configuration of the product. The 1532E antennas can be mounted on a wall, pole and/or tower mounted. Please refer to the *Ordering Guide* for a list of supported antennas.

The 1532E access point supports a variety of antennas designed for outdoor use with radios operating in the 2.4-GHz and 5-GHz frequency bands. The 1532 supports the external antennas listed in the following sections.

Cisco Aironet Dual-Band Omnidirectional Antenna (AIR-ANT2547V-N, AIR-ANT2547VG-N)

The Dual-Band Omnidirectional Antenna, referred to as a “stick” antenna, is designed for outdoor use with Cisco Aironet Outdoor Access Points with radios operating in the 2.4-GHz and 5-GHz frequency bands (Figure 2-16). Basic operating features of the antenna are:

- Omnidirectional collinear array
- Operates in the 2.4 GHz and 5 GHz frequency bands
- Gain:
 - 2400–2483 MHz — 4-dBi
 - 5250–5875 MHz — 7-dBi

The antenna is designed to create an omnidirectional broadcast pattern. To achieve this pattern, mount the access point clear of any obstructions to the sides of the radiating element.

For detailed information on this antenna, refer to the *Cisco Aironet Dual-Band Omnidirectional Antenna (AIR-ANT2547V-N, AIR-ANT2547VG-N)* document. Follow all safety precautions when installing the antennas. For information on safety, refer to “[Safety Precautions when Installing Antennas](#)” section on [page 2-29](#).

Figure 2-16 Cisco Aironet Dual-Band Omnidirectional Antenna - Installed Only on Model AIR-CAP1532E-x-K9

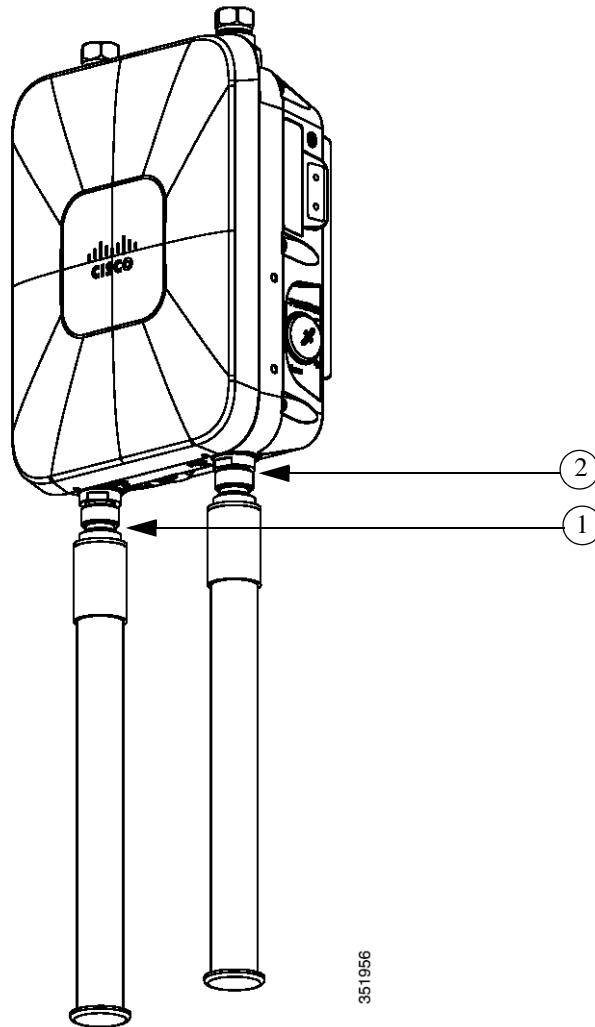

1	Antenna connected to antenna port 1(Type-N connector) (TX/RX)	2	Antenna connected to antenna port 2(Type-N connector) (TX/RX)
---	---------------------------------------------------------------	---	---------------------------------------------------------------

Cisco Aironet 2.4-GHz/5-GHz 8-dBi Directional Antenna (AIR-ANT2588P3M-N)

The Cisco Aironet 2.4-GHz/5-GHz 8-dBi Directional Antenna is designed for outdoor use with Cisco Aironet Outdoor Access Points with radios operating in both the 2.4-GHz and 5-GHz frequency bands. This antenna has 8-dBi gain in both bands.

For detailed information on this antenna, refer to the *Cisco Aironet 2.4-GHz/5-GHz 8-dBi Directional Antenna (AIR-ANT2588P3M-N)* document. Follow all safety precautions when installing the antennas, for information on safety, refer to “[Safety Precautions when Installing Antennas](#)” section on page 2-29.

Figure 2-17 Cisco Aironet 2.4-GHz/5-GHz 8-dBi Directional Antenna - Installed Only on Model AIR-CAP1532E-x-K9

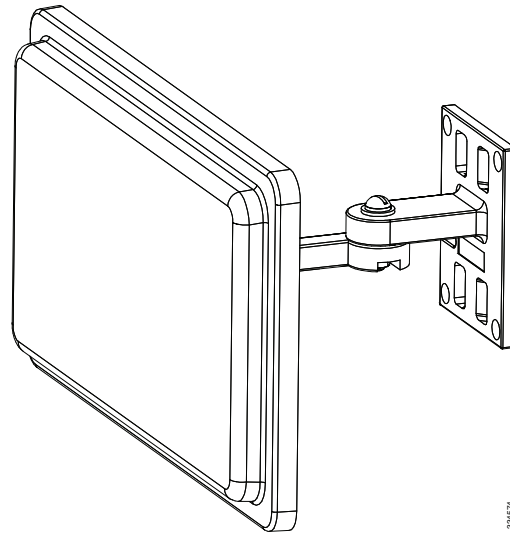
**Note**

When installing the AIR-ANT2588P3M-N with the Cisco Aironet 1530 Series AP, connect the outermost antenna ports (marked '1' in [Figure 2-18](#)) to the AP's dual band antenna ports.

Figure 2-18 Antenna Ports For Connection to AP's Dual Band Ports

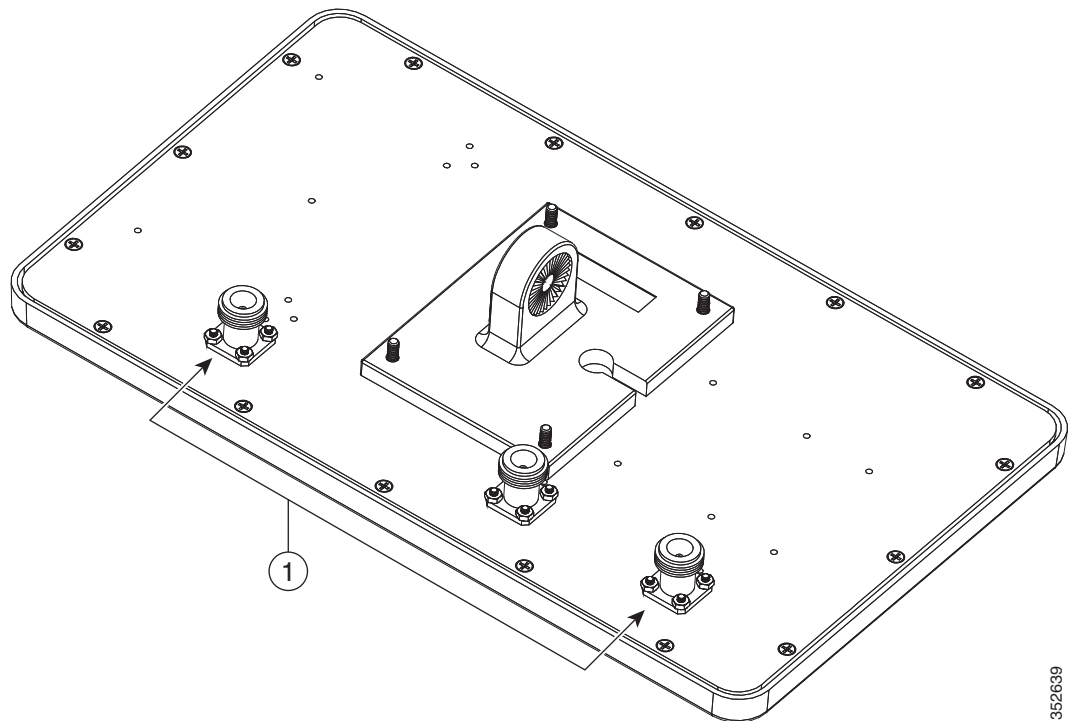

Cisco Aironet 5-GHz 14-dBi 2-Port Directional Antenna (AIR-ANT5114P2M-N)

The Cisco Aironet 5-GHz 14-dBi 2-Port Directional Antenna is designed for outdoor use with Cisco Aironet Outdoor Access Points with radios operating in the 5-GHz frequency band. This antenna has 14-dBi in the 5-GHz band.

For more information, see the *Cisco Aironet 5-GHz 14-dBi Directional Antenna* document, at the following URL:

<http://www.cisco.com/c/en/us/td/docs/wireless/antenna/installation/guide/ant5114p2m-n.html>.

For detailed information on this antenna, see the *Cisco Aironet 5-GHz 14-dBi Directional Antenna (AIR-ANT5114P2M-N)* document. Follow all safety precautions when installing the antennas, for information on safety, refer to “[Safety Precautions when Installing Antennas](#)” section on page 2-29.

Figure 2-19 Cisco Aironet 5-GHz 14-dBi Directional Antenna - Installed Only on Models AIR-CAP1532E-x-K9

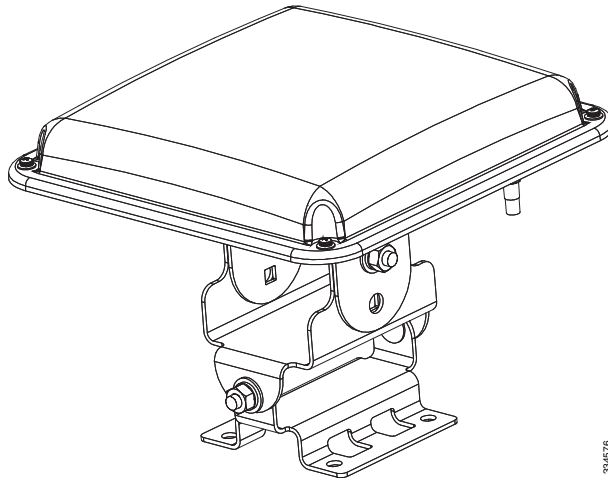

334576

Cisco Aironet 2.4-GHz 13-dBi 2-Port Directional Antenna (AIR-ANT2413P2M-N)

The Cisco Aironet 2.4-GHz 13-dBi 2-Port Directional Antenna is designed for outdoor use with Cisco Aironet Outdoor Access Points with radios operating in the 2.4-GHz frequency band. This antenna has 13-dBi gain in the 2.4-GHz frequency band.

For detailed information on this antenna, refer to the *Cisco Aironet 2.4-GHz 13-dBi Directional Antenna (AIR-ANT2413P2M-N)* document. Follow all safety precautions when installing the antennas, for information on safety, refer to [“Safety Precautions when Installing Antennas”](#) section on page 2-29.

Figure 2-20 *Cisco Aironet 2.4-GHz 13-dBi Directional Antenna - Installed Only on Models AIR-CAP1532E-x-K9*

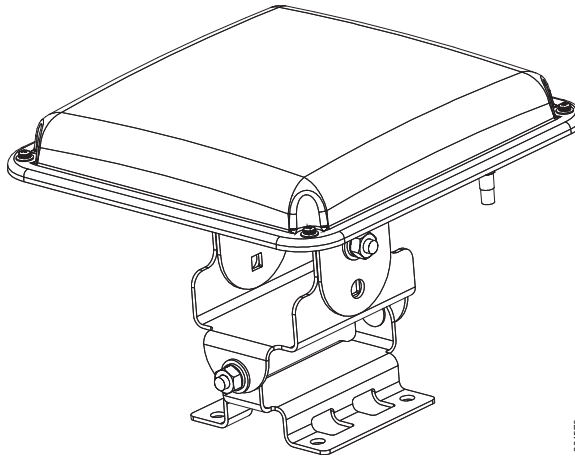

334576

Cisco Aironet 2.4-GHz 5-dBi Omnidirectional Antenna (AIR-ANT2450V-N)

The Cisco Aironet 2.4-GHz 5-dBi Omnidirectional Antenna is designed for outdoor use with Cisco Aironet Outdoor Access Points with radios operating in the 2.4-GHz frequency band. This antenna has a 5-dBi gain in the 2.4-GHz band.

For detailed information on this antenna, refer to the document *Cisco Aironet 5-dBI Omnidirectional Antenna (AIR-ANT2450V-N)*. Follow all safety precautions when installing the antennas. For information on safety, refer to [“Safety Precautions when Installing Antennas”](#) section on page 2-29.

Figure 2-21 Cisco Aironet 2.4-GHz 5-dBi Omni Antenna - Installed Only on Model AIR-CAP1532E-x-K9



Cisco Aironet 2.4-GHz 8-dBi Omnidirectional Antenna (AIR-ANT2480V-N)

The Cisco Aironet 2.4-GHz 8-dBi Omnidirectional Antenna is designed for outdoor use with Cisco Aironet Outdoor Access Points with radios operating in the 2.4-GHz frequency band. This antenna has 8-dBi gain in the 2.4-GHz frequency band.

For detailed information on this antenna, refer to the document *Cisco Aironet 8-dBi Omnidirectional Antenna (AIR-ANT2480V-N)*. Follow all safety precautions when installing the antennas, for information on safety, refer to [“Safety Precautions when Installing Antennas”](#) section on page 2-29.

Figure 2-22 Cisco Aironet 2.4-GHz 8-dBi Omni Antenna - Installed Only on Model AIR-CAP1532E-x-K9i

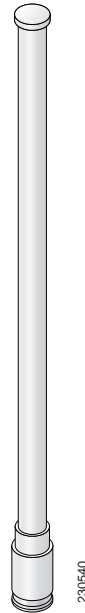

Cisco Aironet 5-GHz 8-dBi Omnidirectional Antenna (AIR-ANT5180V-N)

The Cisco Aironet 5-GHz 8-dBi Omnidirectional Antenna is designed for outdoor use with Cisco Aironet Outdoor Access Points with radios operating in the 5-GHz frequency band. This antenna has 8-dBi gain in the 5-GHz frequency band.

For detailed information on this antenna, refer to the document *Cisco Aironet 8-dBi Omnidirectional Antenna (AIR-ANT5180V-N)*. Follow all safety precautions when installing the antennas, for information on safety, refer to [“Safety Precautions when Installing Antennas”](#) section on page 2-29.

Figure 2-23 Cisco Aironet 5-GHz 8-dBi Omnidirectional Antenna - Installed Only on Model AIR-CAP1532E-x-K9

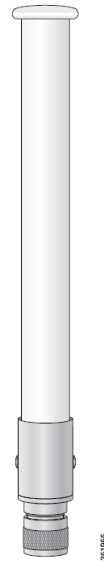

Antenna N-Type Connector Locations

The access point antenna N-type connectors are located on the top and the bottom of model AIR-CAP1532E-x-K9. The N-type connectors support variety of the Cisco Aironet antennas. For detailed information on these antennas, refer to [Antenna Configurations, page 2-29](#). [Figure 2-24](#) shows the antenna port locations viewed from the RF cover side.

Figure 2-24 Antenna Port Locations - Model AIR-CAP1532E-x-K9

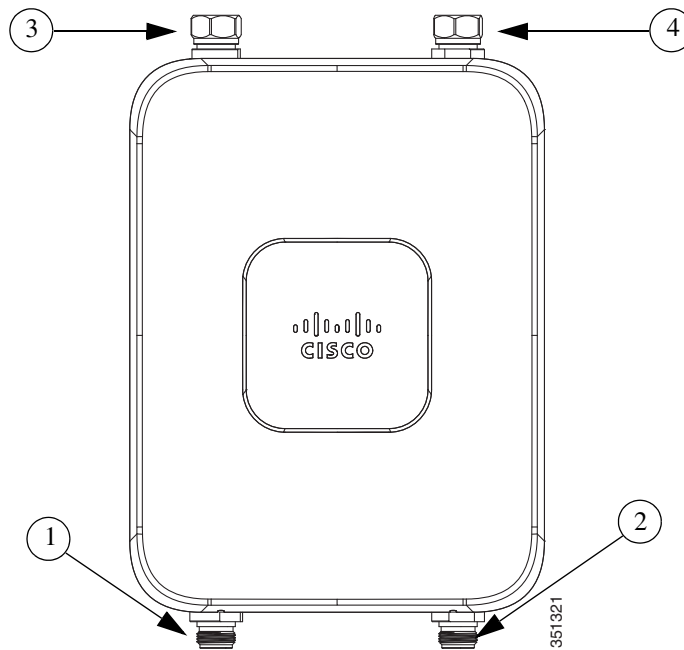

1	Antenna port 1 – Type N connector	2	Antenna port 2- Type N connector
3	Antenna port 3– Type N connector (with cap)	4	Antenna port 4- Type N connector (with cap)

Installing a Lightning Arrestor

Overvoltage transients can be created through lightning static discharges, switch processes, direct contact with power lines, or through earth currents. The Cisco Aironet AIR-ACC245LA-N Lightning Arrestor limits the amplitude and duration of disturbing interference voltages and improves the over voltage resistance of in-line equipment, systems, and components. A lightning arrestor installed according to these mounting instructions balances the voltage potential, thus preventing inductive interference to parallel signal lines within the protected system.

Installation Considerations

Cisco recommends that you bulkhead mount the lightning arrestor so it can be installed as a wall-feed through on the wall of the protected space.

The importance of obtaining a good ground and bonding connection cannot be overstressed. Consider these points when grounding the lightning arrestor:

- Connect the lightning arrester components directly to the grounding point.
- The contact points of the ground connection must be clean and free of dust and moisture.
- Tighten threaded contacts to the torque specified by the manufacturer.

Installation Notes

This lightning arrester is designed to be installed between the antenna cable that is attached to an outdoor antenna and the Cisco Aironet wireless device. You can install the lightning arrester either indoors or outdoors. It can be connected directly to a wireless device having an external N connector. It can also be mounted inline or as a feed-through. Feed-through installations require 5/8 in. (16 mm) hole to accommodate the lightning arrester.



Note

This lightning arrester is part of a lightning arrester kit. The kit contains a lightning arrester and a grounding lug.



Note

When you install the lightning arrester, follow the regulations or best practices applicable to lightning protection installation in your local area.

Installing the Lightning Arrester Outdoors

If you install the lightning arrester outdoors, use the supplied ground lug and a heavy wire (#6 solid copper) to connect it to a good earth ground, such as a ground rod. The connection should be as short as possible.

Figure 2-25 Lightning Arrester Details

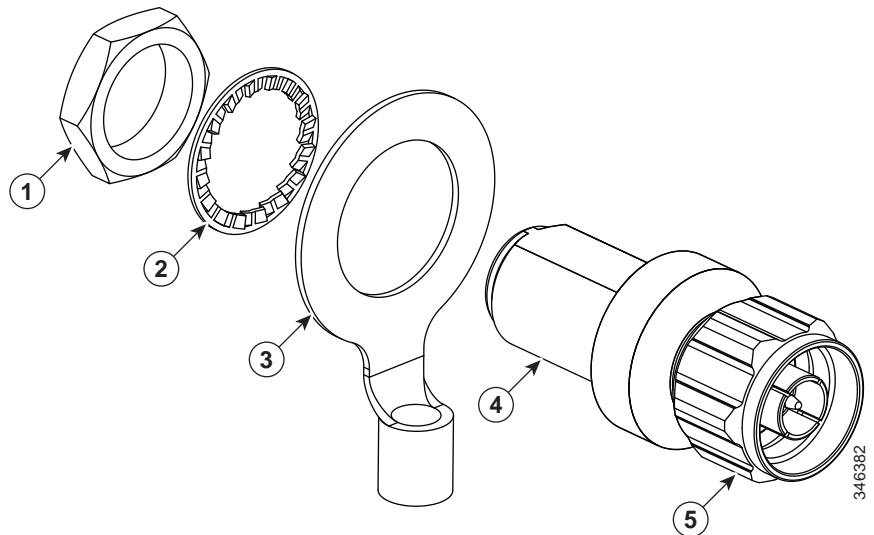

1	Nut	4	Unprotected side (to antenna)
2	Lockwasher	5	Protected side (to wireless device)
3	Ground lug		

Cable for the Lightning Arrestor

Coaxial cable loses efficiency as the frequency increases, resulting in signal loss. The cable should be kept as short as possible because cable length also determines the amount of signal loss (the longer the run, the greater the loss).

Cisco recommends a high-quality, low-loss cable for use with the lightning arrestor.

Grounding the Access Point

The access point must be grounded before connecting power.



Warning

This equipment must be externally grounded using a customer-supplied ground wire before power is applied. Contact the appropriate electrical inspection authority or an electrician if you are uncertain that suitable grounding is available. Statement 366



Warning

Installation of the equipment must comply with local and national electrical codes. Statement 1074

In all outdoor installations and when powering the access point with AC power, you must follow these instructions to properly ground the case:

Step 1 If using insulated 6-AWG copper ground wire, strip the insulation as required for the grounding lug.

Step 2 Use the appropriate crimping tool to crimp the bare 6-AWG copper ground wire to the supplied grounding lug.



Note The grounding lug and hardware used must comply with local and national electrical codes.

Step 3 Open the anti-corrosion sealant (supplied), and apply a liberal amount over the metal surface where the ground strap screw holes are located (see [Figure 1-5](#)).

Step 4 Connect the grounding lug to the access point grounding screw holes (see [Figure 1-5](#)) using the supplied two Phillips head screws (M4 x10 mm) with lock washers. Tighten the grounding screw to 22 to 24 lb-in (2.49 to 2.71 Nm).

Step 5 If necessary, strip the other end of the ground wire and connect it to a reliable earth ground, such as a grounding rod or an appropriate grounding point on a metal streetlight pole that is grounded (see [Figure 2-3](#)).

Powering the Access Point



Warning

Installation of the equipment must comply with local and national electrical codes. Statement 1074

**Warning**

This equipment must be externally grounded using a customer-supplied ground wire before power is applied. Contact the appropriate electrical inspection authority or an electrician if you are uncertain that suitable grounding is available. Statement 366

**Warning**

Do not work on the system or connect or disconnect cables during periods of lightning activity. Statement 1001

The 1532 access point supports these power sources:

- DC power – 24- 57 VDC
- Power-over-Ethernet (PoE)

The 1532 access point can be powered via the PoE input from an in-line power injector or a suitably powered switch port. Depending on the configuration and regulatory domain, the required power for full operation is UPoE. For the 1532E, 802.3at power is sufficient for all regulatory domains and full 2x2 MIMO operation on both 2.4 and 5 GHz radios. Either the AIR-PWRINJ-30= or the AIR-PWRINJ1500-2= power injector can be used.

For the 1532I, UPoE powered switch port or the AIR-PWRINJ1500-2= power injector is required for full operation of the 3x3 MIMO on the 2.4 GHz radio in the regulatory domains that allow for high 2.4 GHz transmit power (Regulatory domains -A, -D, -F, -K, -N, -Q, -T, -Z). If the 1532I is powered by a PoE+ (802.3at power) switch port or the AIR-PWRINJ-30= power injector, then the access point will automatically disable one of the 2.4 GHz transmitters and the radio will operate in 2x3 MIMO mode.

Table 2-7 AP 1530 Power Matrix

Model	Configuration	Regulatory Domain	Switch Power	AIR-PWRINJ1500-2=	AIR-PWRINJ-30=	AC/DC Power Adapter AIR-PWRADPT-1530=
1532I	3x3:3 (2.4 GHz) 2x3:2 (5 GHz)	A, D, K, N, Q, T, Z	UPoE	Yes		Yes
	One Tx disabled ¹ 2x3:2 (2.4 GHz) 2x3:2 (5 GHz)	A, D, K, N, Q, T, Z	802.3at PoE+	Not Applicable	Yes	Not Applicable
	3x3:3 (2.4 GHz) 2x3:2 (5 GHz)	C, E, F, H, M, R, S	802.3at PoE+	Yes	Yes	Yes
1532E	2x2:2 (2.4 GHz) 2x2:2 (5 GHz)	All	802.3at PoE+	Yes	Yes	Yes

1. Not user configurable. AP will automatically disable one of the 2.4 GHz Tx if it detects only 802.3at power input.

**Caution**

Do not place the power injector in an unprotected outdoor environment because water could get into the power injector and cause a short circuit and possible fire.

**Warning**

Connect the unit only to DC power source that complies with the Safety Extra-Low Voltage (SELV) requirements in IEC 60950 based safety standards Statement 1033

Connecting a 1530 Series Power Injector

The 1530 Series Access Points support the following power injectors:

- AIR-PWRINJ1500-2= — 100-240 VAC input, indoor use only
- AIR-PWRINJ-30= — 100-240 VAC input, indoor use only

The power injector provides (AIR-PWRINJ1500-2=) 56 VDC to the access point over the Ethernet cable and supports a total end-to-end Ethernet cable length of 100 m (328 ft) from the switch to the access point.

When your access point is powered by an optional power injector, follow these steps to complete the installation:

Step 1 Before applying PoE to the access point, ensure that the access point is grounded (see the [“Grounding the Access Point”](#) section on page 2-40).

Step 2 Review [Figure 2-2](#) to identify the components needed for the installation.



Note The 1500 power injector can only be used in an indoor environment, therefore, the cable from the injector must travel from the protected location to the outside mounted access point.

Step 3 Connect a CAT5e or better Ethernet cable from your wired LAN network to the power injector.

**Warning**

To reduce the risk of fire, use only No. 26 AWG or larger telecommunication line cord. Statement 1023



Note The installer is responsible for ensuring that powering the access point from this type of power injector is allowed by local and/or national safety and telecommunications equipment standards.



Tip To forward bridge traffic, add a switch between the power injector and controller. Refer to the *Cisco Wireless Mesh Access Points, Design and Deployment Guide, Release 7.0* for more information.

Step 4 Ensure that the antennas are connected and that a ground is attached to the access point before you apply power to the access point.

Step 5 Connect a shielded outdoor-rated Ethernet (CAT5e or better) cable between the power injector and the PoE-in connector of the access point (see [Figure 2-26](#)).

Step 6 Connect the Ethernet cable to the access point PoE-In port (see [“Connecting an Ethernet Cable to the Access Point”](#) section on page 2-43).

Step 7 Continue with [What to Do Next](#), page 2-54.

Connecting an Ethernet Cable to the Access Point

You need to supply these tools and materials:

- Shielded outdoor-rated Ethernet (CAT5e or better) cable with 0.2 to 0.35 in. (0.51 to 0.89 cm) diameter
- RJ-45 connector and installation tool
- Adjustable Wrench or 28 mm box wrench
- Large Phillips or Flat Blade screwdriver

To connect the shielded Ethernet cable to the access point, follow these steps:

Step 1 Disconnect power to the power injector, and ensure all power sources to the access point are turned off.



Warning

This unit might have more than one power supply connection. All connections must be removed to de-energize the unit. Statement 1028

Step 2 Ensure a 6 AWG ground wire is connected to the access point (see the [“Grounding the Access Point”](#) section on page 2-40).

Step 3 Use a large Phillips or Flat Blade screw driver to remove the Ethernet connector plug from the access point. Do not discard plug and rubber seal unless you are certain that the port will not have to be re-plugged (see [Figure 2-26](#) for the location).

Figure 2-26 Access Point PoE-In Connector- AP 1532I

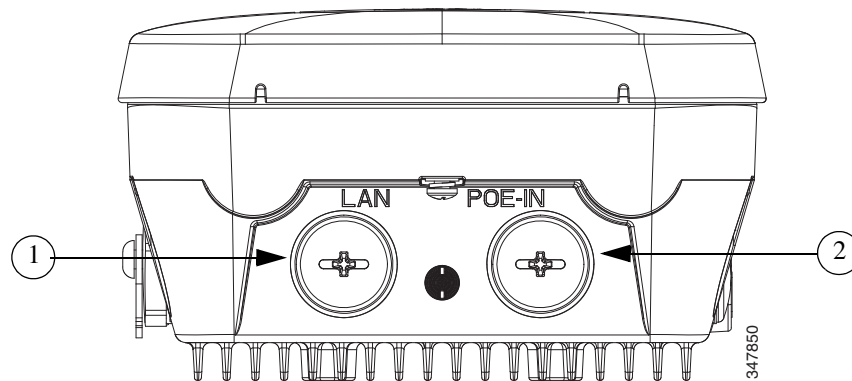

1	LAN port (covered)	2	PoE-In port (covered)
---	--------------------	---	-----------------------



Note

For information on data cable entry, refer to [Figure 1-1](#)

- Step 4** Loosen the Thread-Lock sealing nut of the cable gland by turning it counter clockwise, but do not remove it (see [Figure 2-27](#)).



Note Verify that the cable gland has a rubber seal and ensure that it is not damaged.



Warning

Failure to install the cable gland and rubber gasket properly will cause the cable grip to leak.

Figure 2-27 Cable Gland

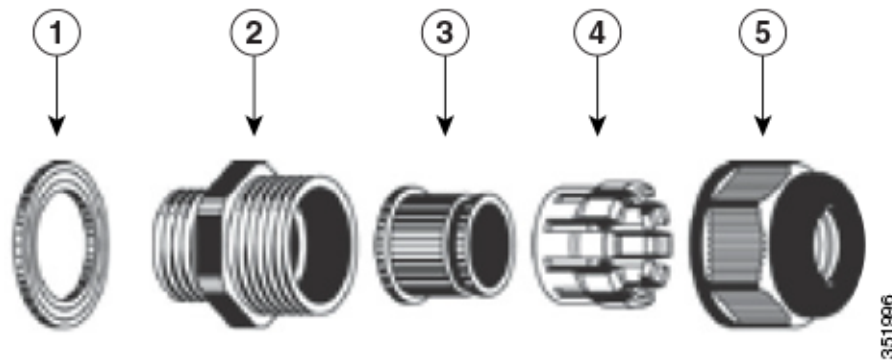

1	Washer (Rubber Gasket)	2	Body
3	Sealing insert	4	Clamping claw
5	Thread-lock sealing nut		

- Step 5** Insert the unterminated end of the Ethernet cable through the sealing nut end of the cable gland (see [Figure 2-27](#)), and pull several inches of cable through the adapter.
- Step 6** Install an RJ-45 connector on the unterminated end of the Ethernet cable using your Ethernet cable installation tool.



Warning

To reduce the risk of fire, use only No. 26 AWG or larger telecommunication line cord. Statement 1023



Warning

When installing the RJ-45 connector, ensure that cable gland and the rubber gasket are present and installed properly, to avoid water leakage into the enclosure. See [Figure 2-27](#) and [Figure 2-28](#).

- Step 7** Carefully insert the RJ-45 cable connector into the Ethernet port opening on the access point, and connect to the internal Ethernet connector (see [Figure 2-28](#)).

Figure 2-28 Inserting RJ-45 Connector into the Ethernet Port Opening in Case

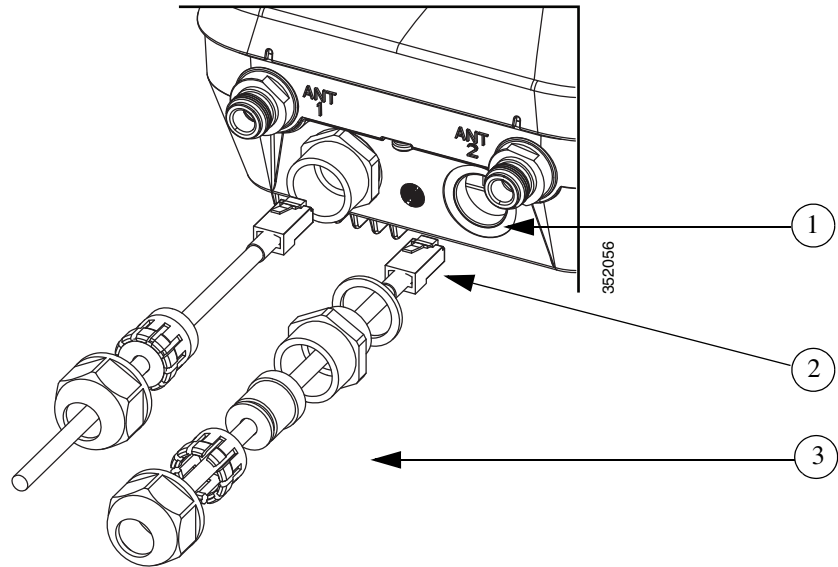

1	Ethernet port opening in access point case.	2	RJ-45 connector, on shielded outdoor-rated Ethernet (CAT5e or better) cable
3	Exploded view of the cable gland, on the Ethernet cable.		

- Step 8** Slide the cable gland with the rubber seal towards the access point, and screw the threaded end of the body into the access point, and hand-tighten.
- Step 9** Use an adjustable wrench or a 28-mm wrench to tighten the threaded end of the body into the enclosure. Tighten to 15 lb-in.
- Step 10** Use an adjustable wrench and tighten the thread-lock seal nut to 15 lb-in.
- Step 11** Ensure that the antennas are connected to the access point before you apply power to the access point.
- Step 12** Route your Ethernet cable, and cut off any excess cable.
- Step 13** Install an RJ-45 connector on the unterminated cable end, and insert it into the power injector. For typical installation components, see [Figure 2-2](#).
- Step 14** Turn on power to the power injector.

Connecting a DC Power Cable to the Access Point

When powering the access point with DC power, you must ensure that DC power can be conveniently removed from the unit. The power should not be removed by disconnecting the DC power connector on the unit.



Warning

A readily accessible two-poled disconnect device must be incorporated in the fixed wiring.
Statement 1022

**Warning**

Connect the unit only to DC power source that complies with the safety extra-low voltage (SELV) requirements in IEC 60950 based safety standards. Statement 1033

To connect a DC power cable, you need to supply these tools and material:

- Shielded outdoor-rated DC power cable (minimum 18 AWG) with outside cable diameter of 0.20 to 0.35 inch (0.51 to 0.89 cm).
- Adjustable or open-end wrench
- Small flat screw driver
- Two-pin DC power connector (Cisco supplied)

To connect the DC power cable to the access point, follow these steps:

Step 1 Before connecting DC power to the access point, ensure that the ground is connected to the access point (see the “[Grounding the Access Point](#)” section on page 2-40).

Step 2 Turn off all power sources to the access point, including the DC power source.

**Warning**

This unit might have more than one power supply connection. All connections must be removed to de-energize the unit. Statement 1028

**Caution**

When installing DC power to the access point, always connect the access point end of the cable **FIRST**. When removing the DC power connector, always disconnect the access point end of the cable **LAST**.

Step 3 Use a large Phillips or Flat Blade screw driver to remove the Ethernet connector plug from the access point. Do not discard plug and rubber seal unless you are certain that the port will not have to be re-plugged. (see [Figure 2-29](#) for the location of the DC power connector).

Figure 2-29 Access Point DC Power Connector and Ground Lug (Both AP 1532 Models)

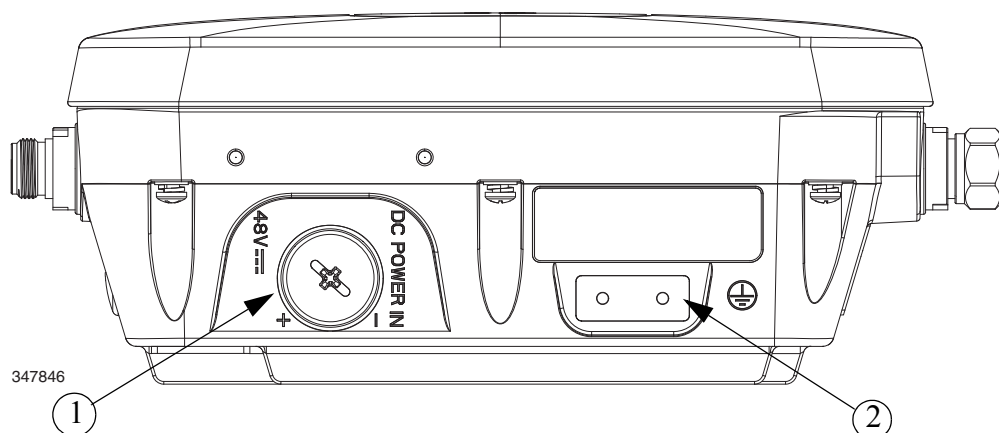

1	DC power port	2	Ground lug location
---	---------------	---	---------------------

- Step 4** Loosen the thread-Lock sealing nut of the cable gland by turning it counter clockwise, but do not remove (see [Figure 2-30](#)).



Note Verify that the cable gland has a rubber seal and ensure that it is not damaged.



Warning

Failure to install the Cable Gland properly will cause the cable grip to leak.

Figure 2-30 Cable Gland

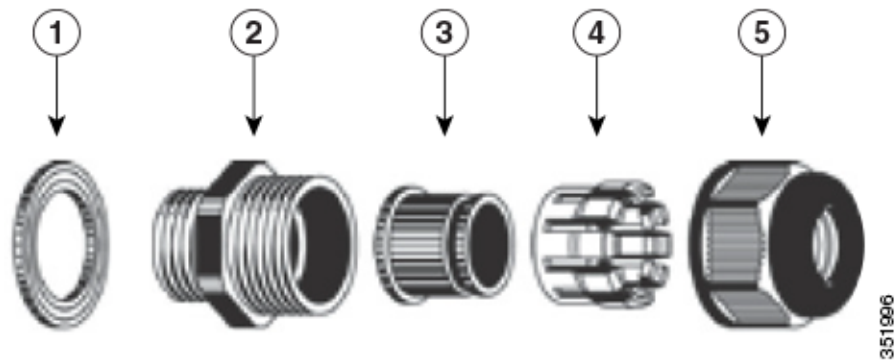

1	Washer (Gasket)	2	Body
3	Sealing insert	4	Clamping claw
5	Thread-lock sealing nut		



Note The cable gland accepts a cable diameter of 0.20 to 0.35 in. (0.51 to 0.89 cm).

- Step 5** Insert a bare end of the DC power cable into the rounded end of the cable gland (see [Figure 2-30](#)), and pull approximately 6 inches of cable through the adapter.



Warning

When installing the DC power cable, ensure that cable gland and the rubber gasket are present and installed properly, to avoid water leakage into the enclosure. See [Figure 2-30](#) and [Figure 2-32](#).

- Step 6** Strip the DC cable jacket back about 1 inch to expose the wires and strip the insulation about 3/8 inch (9.5 mm) from each wire.
- Step 7** Insert each wire into the two-position terminal strip (supplied), and tighten each wire using a 0.1 inch (0.25 cm) flat screw driver (see [Figure 2-31](#)).

Figure 2-31 Two-Position Terminal Strip



1	Securing screws	3	Wire opening for DC +
2	Wire opening for ground (DC return)		

Step 8 Insert the two-position terminal strip into the DC power opening in the access point case, and carefully push the terminal strip into the internal connector (see [Figure 2-32](#)).



Note Ensure that the polarity of the terminal strip properly matches the polarity markings on the enclosure (see [Figure 2-33](#))

Figure 2-32 Inserting the Terminal Strip into the DC Power Opening in the Access Point Case

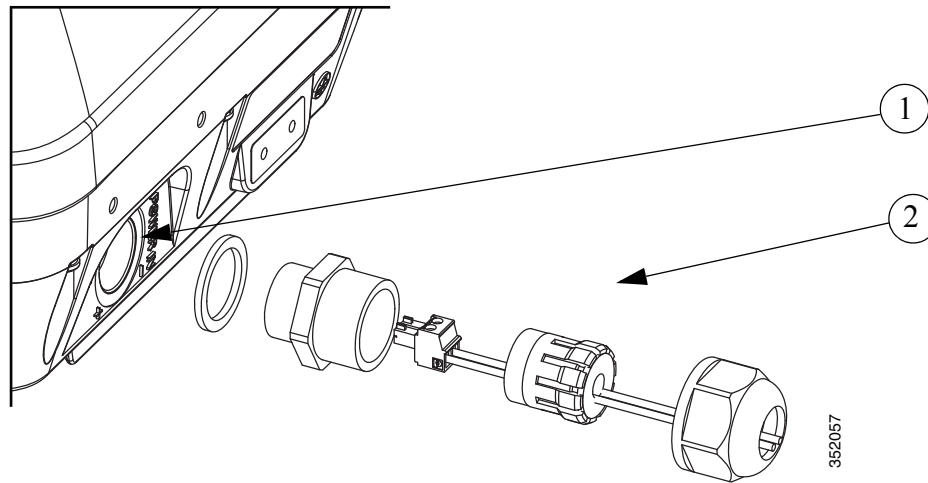

1 DC power opening in access point case. Also see Figure 2-33 .	2 Exploded view of the cable gland on the DC power cable
---------------------------------------------------------------------------------	----------------------------------------------------------

Figure 2-33 DC Power Opening in the Access Point Case

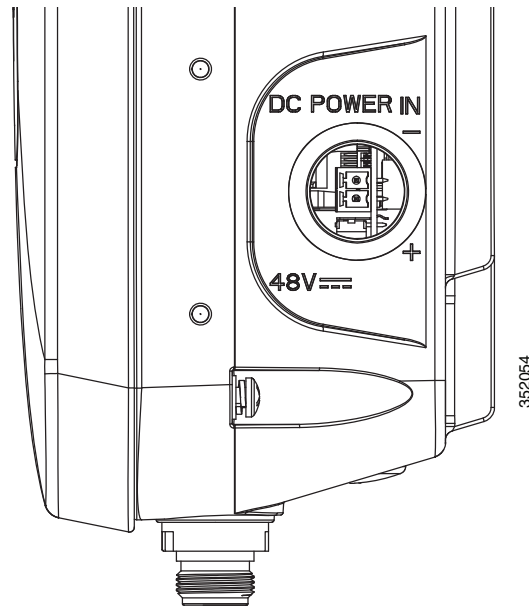

- Step 9** Slide the cable gland with the rubber seal towards the access point, and screw the threaded end of the body into the access point, and hand-tighten.
- Step 10** Use an adjustable wrench, a 28-mm wrench to tighten the threaded end of the body to 15 lb-in.
- Step 11** Use an adjustable wrench and tighten the thread-lock seal nut to 15 lb-in.
- Step 12** Ensure that the antennas are connected to the access point before you apply power to the access point.
- Step 13** Turn on the DC power at the designated circuits.

Connecting Streetlight AC Power

The access point can be installed on a streetlight pole and powered from a streetlight outdoor light control using the optional streetlight power tap adapter (AIR-PWR-ST-LT-R3P) and AC/DC power adapter, AIR-PWRADPT-1530=. The AC/DC power adapter is used inline from the street light tap to the 1530 DC connector. The AC power tap only can be used with the AC/DC power adapter



Caution

The access point can be powered by a light pole twist-lock outdoor light control that provides 100-to 277-VAC 50/60 Hz power. Do not connect to an outdoor light control powered by higher voltages.

When powering the access point with AC power other than the streetlight power tap adapter, you must ensure that the following conditions are observed:

1. AC power can be conveniently removed from the unit. The power should not be removed by disconnecting the AC power connector on the unit.



Warning

A readily accessible two-poled disconnect device must be incorporated in the fixed wiring. Statement 1022



Caution

Before connecting or disconnecting a power cord, you must remove AC power from the power cord using a suitable service disconnect.

2. You must protect any AC power plugs and AC receptacles from water and other outdoor elements. You can use a UL-listed waterproofing enclosure suitable for covering the AC receptacle and AC power plug that supplies power to the unit as described in Article 406 of the NEC.
3. When you install the access point outdoors or in a wet or damp location, the AC branch circuit that powers the access point should have ground fault protection (GFCI), as required by Article 210 of the National Electrical Code (NEC).



Warning

Be very careful when connecting the streetlight adapter to Category 3 pole-top power. If you are not careful, you may electrocute yourself or fall. Statement 363

To install an access point on a streetlight pole, follow these steps:

Step 1 Before beginning the installation, ensure the AC power to the streetlight pole is turned off.

Step 2 Turn off power to the AC power source at the designated circuits.



Warning

This unit might have more than one power supply connection. All connections must be removed to de-energize the unit. Statement 1028



Caution

For your safety, when connecting the access point AC power connector, always connect the access point end of the cable FIRST. When removing the AC power connector, always disconnect the access point end of the cable LAST.

- Step 3** When using the streetlight power tap adapter (AIR-PWR-ST-LT-R3P=), ensure that the access point is mounted within 3 feet (1 m) of the outdoor light control.
- Step 4** Ensure that a 6-AWG ground wire is attached to the access point (see [Figure 2-34](#)) and connected to the streetlight pole (for instructions see [Grounding the Access Point](#), page 2-40).

Figure 2-34 Using the Streetlight Power Tap Adapter

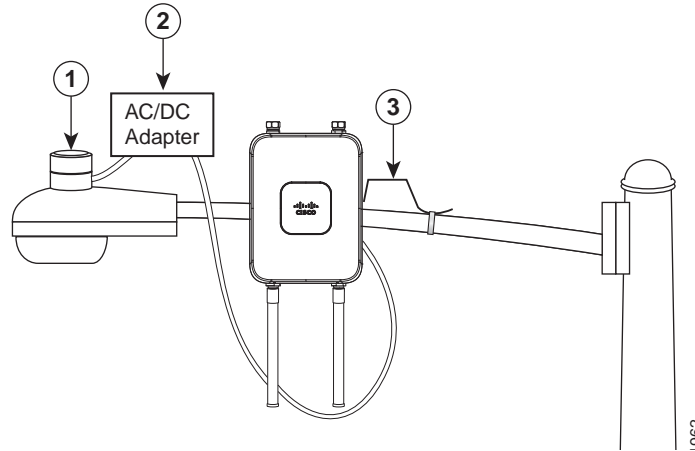

1	Outdoor light control	3	6-AWG copper grounding wire
2	AC/DC power adapter		



Note Deployment of the AP as shown in the streetlight deployment in [Figure 2-34](#) requires an alternate AP mounting kit. See [Mounting the Access Point](#) section for more information.

- Step 5** Ensure that the streetlight power tap adapter, which uses a 3-pronged LC-10 twist-lock adapter, is placed between the outdoor light control and its fixture (refer to [Figure 2-34](#)). The LC-10 twist-lock adapter is designed to be used with LC-10 listed outdoor light controls operating at 100 to 480 VAC, 50 to 60 Hz.
- Step 6** Disconnect the outdoor light control from its fixture.
- Step 7** Verify that the voltage available at the fixture is between 100 and 480 VAC, 50 to 60 Hz.
- Step 8** Turn off power to the fixture at the designated circuits.



Caution When installing the streetlight power tap adapter to the access point AC power connector, always connect the access point end of the cable FIRST. When removing the streetlight power tap adapter, always disconnect the access point end of the cable LAST.



Note Ensure that your antennas are connected to the access point before you apply power to the access point.

- Step 9** Connect the streetlight power tap adapter to the access point AC/DC power adapter. See [Wiring the Streetlight Power Tap Adapter to the AC/DC Power Adapter](#).

Figure 2-35 Access Point DC Power Connector and Ground Lug (Both AP 1532 Models)

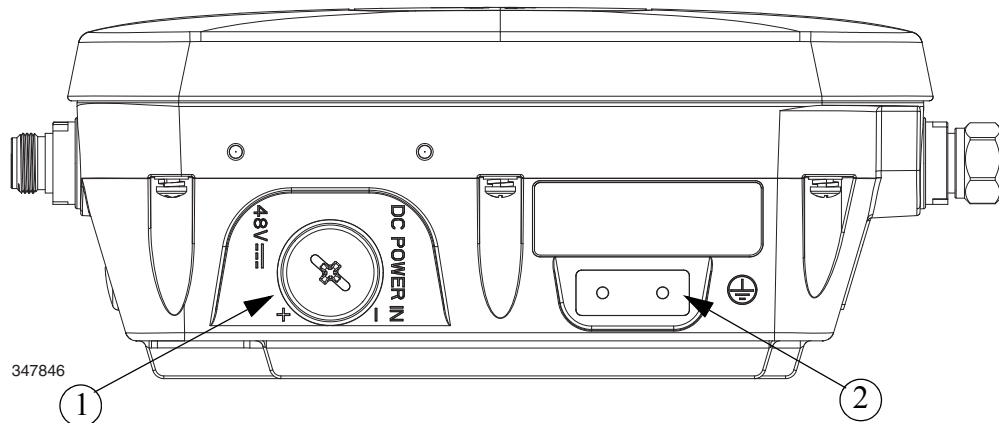

1	DC power port	2	Ground lug location
---	---------------	---	---------------------

- Step 10** Plug the streetlight power tap adapter into the outdoor light control fixture, as shown in [Figure 2-34](#).
- Step 11** Plug the outdoor light control into the streetlight power tap adapter.
- Step 12** Ensure that the antennas are connected to the access point before you apply power to the access point.
- Step 13** Turn on the power to the outdoor light control fixture at the designated circuits.

Wiring the Streetlight Power Tap Adapter to the AC/DC Power Adapter

The AC plugs of the streetlight power tap adapter (AIR-PWR-ST-LT-R3P=) and the AC/DC power adapter (AIR-PWRADPT-1530=) are incompatible. Hence, you need to connect the cables to wire them together, using the illustration in [Figure 2-36](#). Ensure that you follow local electrical and safety codes when making and protecting this connection.



Warning

Ensure that all electrical power is turned off before making this connection.



Warning

Follow all local wiring and electrical codes when making this connection. Note that the spliced cables may need to be housed in an approved junction box.



Note

- Cut and remove the AC plugs from each cable. Cut just past strain relief to be sure that the cable is not cut too short.
- Ensure that the wiring splice is properly secured and protected.

Figure 2-36 Wiring Streetlight Power Tap Adapter to AC/DC Power Adapter

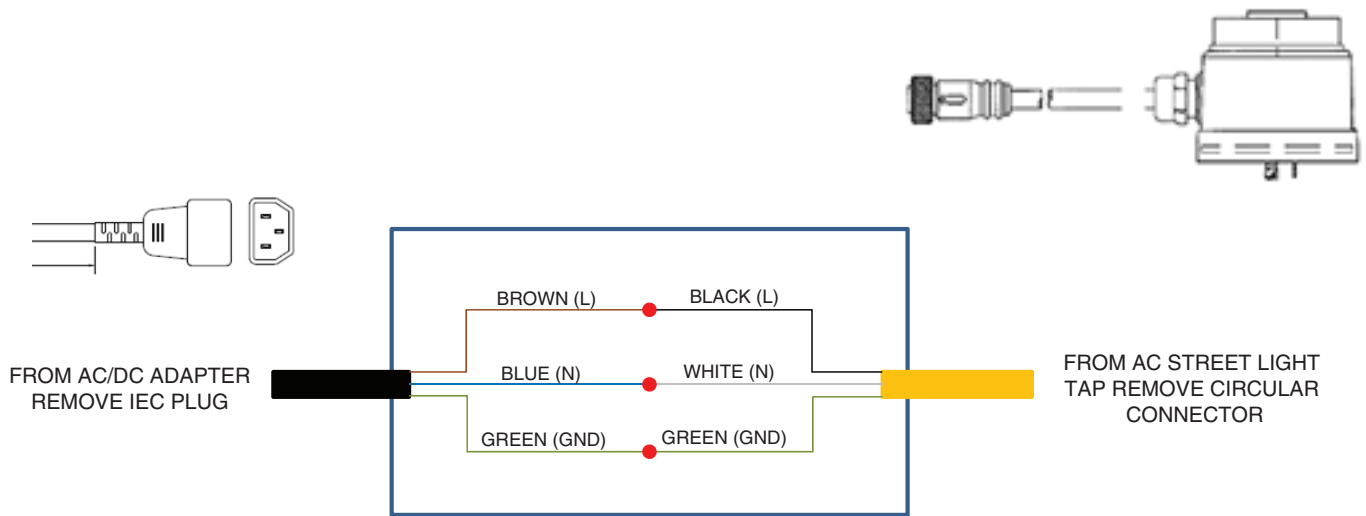

352847

Configuring the Access Point

For information on configuring the access point, see the following documents:

- For Lightweight Access Points and Mesh Access Points, see the *Cisco Wireless LAN Controller Configuration Guide*, which is available at:
http://www.cisco.com/c/en/us/td/docs/wireless/controller/7-6/configuration-guide/b_cg76.html
- For Mesh Access Points, see the *Cisco Wireless Mesh Access Points, Design and Deployment Guide*, which is available at:
<http://www.cisco.com/c/en/us/td/docs/wireless/technology/mesh/7-6/design/guide/mesh76.html>
- For Access Points in autonomous mode, see the *Cisco Aironet Access Points Configuration Guide for Cisco IOS Software*, which is available at:
http://www.cisco.com/c/en/us/td/docs/wireless/access_point/15-3-3/configuration/guide/cg15-3-3.html

What to Do Next

When you power up a MAP that is not connected to a wired Ethernet, fiber-optic, or cable network to the controller, the access point uses the Cisco Adaptive Wireless Path Protocol (AWPP) to bind to another mesh access point (MAP) with the best path to a root access point (RAP) connected to the wired network to a controller. The access point sends a discovery request when powered up. If you have configured the access point in the controller correctly, the controller sends back a discovery response to the access point. When that happens, the access point sends out a join request to the controller, and the controller responds with a join confirmation response. Then the access point establishes a Control And Provisioning of Wireless Access Points (CAPWAP) connection to the controller and gets the shared secret configured on the controller.

Refer to the *Cisco Wireless LAN Controller Configuration Guide* for more information on configuring, monitoring, and operating your access points.



Troubleshooting

This chapter provides troubleshooting procedures for basic problems with the access point. For the most up-to-date, detailed troubleshooting information, refer to the Cisco Technical Support and Documentation website at the following URL:

<http://www.cisco.com/cisco/web/support/index.html>

Sections in this chapter include:

- [Guidelines for Using the Access Points, page 3-2](#)
- [Controller MAC Filter List, page 3-3](#)
- [Using DHCP Option 43, page 3-3](#)
- [Monitoring the Access Point LEDs, page 3-4](#)
- [Verifying Controller Association, page 3-6](#)
- [Changing the Bridge Group Name, page 3-7](#)
- [Access Point Power Injector, page 3-7](#)
- [Accessing the Console Port and the Reset Button, page 3-9](#)

Guidelines for Using the Access Points

You should keep these guidelines in mind when you use the access points:

- The access point only supports Layer 3 CAPWAP communications with the controllers.

In Layer 3 operation, the access point and the controller can be on the same or different subnets. The access point communicates with the controller using standard IP packets. A Layer 3 access point on a different subnet than the controller requires a DHCP server on the access point subnet and a route to the controller. The route to the controller must have destination UDP ports 12222 and 12223 open for CAPWAP communications. The route to the primary, secondary, and tertiary controllers must allow IP packet fragments.

- Before deploying your access points, ensure that the following has been done:
 - Your controllers are connected to switch ports that are configured as trunk ports.
 - Your access points are connected to switch ports that are configured as untagged access ports.
 - A DHCP server is reachable by your access points and has been configured with Option 43. Option 43 provides the IP addresses of the management interfaces of your controllers. Typically, a DHCP server can be configured on a Cisco switch.
 - Optionally, a DNS server can be configured to enable CISCO-CAPWAP-CONTROLLER. Use *local domain* to resolve to the IP address of the management interface of your controller.
 - Your controllers are configured and reachable by the access points.
 - Your controllers are configured with the access point MAC addresses and the MAC filter list is enabled.
 - Your switch must forward DHCP requests.
- After the access points are associated to the controller, you should change the bridge group name (BGN) from the default value. With the default BGN, the mesh access points (MAPs) can potentially try to connect with other mesh networks and slow down the convergence of the network.

Important Notes

Convergence Delays

During deployment, the access points can experience convergence delays due to various causes. The following list identifies some operating conditions that can cause convergence delays:

- A root access point (RAP) attempts to connect to a controller using any of the wired ports (cable, fiber-optic, PoE-in). If the wired ports are operational, the RAP can potentially spend several minutes on each port prior to connecting to a controller.
- If a RAP is unable to connect to a controller over the wired ports, it attempts to connect using the wireless network. This results in additional delays when multiple potential wireless paths are available.
- If a MAP is unable to connect to a RAP using a wireless connection, it then attempts to connect using any available wired port. The access point can potentially spend several minutes for each connection method, before attempting the wireless network again.

Bridge Loop

The access point supports packet bridging between wired and wireless network connections. The same network must never be connected to multiple wired ports on an access point or on two bridged access points. A bridge loop causes network routing problems.

Controller DHCP Server

The controller DHCP server only assigns IP addresses to lightweight access points and wireless clients associated to an access point. It does not assign an IP address to other devices, including Ethernet bridging clients on the mesh access points.

MAP Data Traffic

If the signal on the access point backhaul channel has a high signal-to-noise ratio, it is possible for a MAP to connect to the controller, via parent node, but not be able to pass data traffic, such as pinging the access point. This can occur because the default data rate for backhaul control packets is set to 6 Mb/s, and the backhaul data rate set to auto by the user.

Controller MAC Filter List

Before activating your access point, you must ensure that the access point MAC address has been added to the controller MAC filter list and that **Mac Filter List** is enabled.



Note

The access point MAC address and barcode is located on the bottom of the unit. When two MAC addresses are shown, use the top MAC address.

To view the MAC addresses added to the controller MAC filter list, you can use the controller CLI or the controller GUI:

- Controller CLI—Use the **show macfilter summary** controller CLI command to view the MAC addresses added to the controller filter list.
- Controller GUI—Log into your controller web interface using a web browser, and choose **SECURITY > AAA > MAC Filtering** to view the MAC addresses added to the controller filter list.

Using DHCP Option 43

You can use DHCP Option 43 to provide a list of controller IP addresses to the access points, enabling the access point to find and join a controller. Refer to the product documentation for your DHCP server for instructions on configuring DHCP Option 43. For additional information, refer to the [“Configuring DHCP Option 43” section on page F-1](#).

Monitoring the Access Point LEDs

If your access point is not working properly, look at the LEDs on the bottom of the unit. You can use them to quickly assess the status of the unit. [Figure 3-1](#) shows the location of the access point LEDs.

Figure 3-1 Access Point LEDs –Shown on the Bottom of AP 1532E

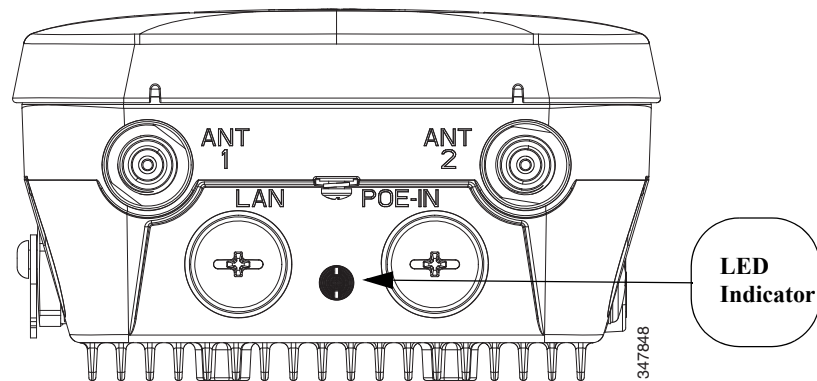

Note

It is expected that there will be small variations in LED color intensity and hue from unit to unit. This is within the normal range of the LED manufacturer specifications and is not a defect.

The access point LED signals are listed in [Table 3-1](#).

Table 3-1 Access Point LED Signals

LED Message Type	Color	Meaning
Boot loader status sequence	Blinking Green	Boot loader status sequence: <ul style="list-style-type: none"> • DRAM memory test in progress • DRAM memory test OK • Board initialization in progress • Initializing FLASH file system • FLASH memory test OK • Initializing Ethernet • Ethernet OK • Starting Cisco IOS • Initialization successful
Boot loader warnings	Blinking Amber	Configuration recovery is in progress (the MODE button has been pushed for 2-3 seconds)
	Solid Red	There is an Ethernet failure or an image recovery (the MODE button has been pushed for 20-30 seconds)
	Blinking Green	An image recovery is in progress (the MODE button has been released)

LED Message Type	Color	Meaning
Boot loader errors	Solid Red	There has been a DRAM memory test failure
	Blinking Red and Amber	There has been a FLASH file system failure
	Blinking Red and Off	This sequence may indicate any of the following: <ul style="list-style-type: none"> Environment variable failure Bad MAC address Ethernet failure during image recovery Boot environment failure No Cisco image file Boot failure
Cisco IOS errors	Solid Red	There has been a software failure; a disconnect then reconnect of the unit power may resolve the issue
	Cycling through Red, Green, Amber and Off	This is a general warning of insufficient inline power.
Association status	Chirping (short blips) Green	This status indicates a normal operating condition. The unit is joined to a controller, but no wireless client is associated with it.
	Solid Green	Normal operating condition with at least one wireless client associated with the unit
Operating Status	Blinking Amber	A software upgrade is in progress
	Cycling through Green, Red and Amber	Discovery/join process is in progress
	Rapidly cycling through Red, Green, Amber and Off	This status indicates that the Access Point location command has been invoked.
	Blinking Red	This status indicates that an Ethernet link is not operational
Alignment Mode	Color	Signal Level (dBm)
	Solid Green	> -44
	Fast blinking Green	-47 to -44
	Medium blinking Green	-50 to -47
	Solid Amber	-53 to -50
	Fast blinking Amber	-57 to -53
	Medium blinking Amber	-60 to -57
	Slow blinking Amber	-63 to -60
	Slow blinking Red	-66 to -63
	Medium blinking Red	-69 to -66
	Fast blinking Red	-72 to -69
	Solid Red	-75 to -72
Off	< -75	

Verifying Controller Association

To verify that your access point is associated to the controller, follow these steps:

-
- Step 1** Log into your controller web interface using a web browser.
You can also use the controller CLI **show ap summary** command from the controller console port.
- Step 2** Click **Wireless**, and verify that your access point MAC address is listed under Ethernet MAC.
- Step 3** Log out of the controller, and close your web browser.
-

Changing the Bridge Group Name

The bridge group name (BGN) controls the association of the access points to a RAP. BGNs can be used to logically group the radios to avoid different networks on the same channel from communicating with each other. This setting is also useful if you have more than one RAP in your network in the same area.

If you have two RAPs in your network in the same area (for more capacity), we recommend that you configure the two RAPs with different BGNs and on different channels.

The BGN is a string of ten characters maximum. A factory-set bridge group name (NULL VALUE) is assigned during manufacturing. It is not visible to you, but allows new access point radios to join a network of new access points. The BGN can be reconfigured from the Controller CLI and GUI. After configuring the BGN, the access point reboots.

After the access points are deployed and associated to the controller, the BGN should be changed from the default value to prevent the MAPs from attempting to associate to other mesh networks.

The BGN should be configured very carefully on a live network. You should always start with the most distant access point (last node) from the RAP and move towards the RAP. If you start configuring the BGN in a different location, then the access points beyond this point (farther away) are dropped, as they have a different BGN.

To configure the BGN for the access points using the controller GUI, follow these steps:

-
- Step 1** Log into your controller using a web browser.
 - Step 2** Click **Wireless**. When access points associates to the controller, the access point name appears in the AP Name list.
 - Step 3** Click on an access point name.
 - Step 4** Find the Mesh Information section, and enter the new BGN in the Bridge Group Name field.
 - Step 5** Click **Apply**.
 - Step 6** Repeat Steps 2 through 5 for each access point.
 - Step 7** Log out from your controller, and close your web browser.
-

Access Point Power Injector

The power injector (AIR-PWRINJ1500-2=) has three LEDs on the front end of the case (see [Figure 3-2](#)). For detailed information on the power injector, see the *Cisco Aironet 1550 Series Outdoor Access Point Power Injector Installation Instructions*.

Figure 3-2 Power Injector Connectors and LEDs



1	Mounting tabs	4	AC POWER LED
2	AP POWER LED	5	TO AP—Ethernet connector (RJ-45) to access point (10/100/1000BASE-T)
3	FAULT LED	6	TO SWITCH—Ethernet connector (RJ-45) to switch (10/100/1000BASE-T)

Monitoring the Power Injector LEDs

You can use the power injector LEDs to check the power injector status. The LEDs provide the following status information:

- AP POWER—Turns solid green after successful discovery; indicates that power injector is supplying power to the access point.
- FAULT—Turns solid red when a fault occurs during discovery mode or power-up. Check Ethernet cables and connections before contacting your support organization for assistance.
- AC POWER—Turns solid green when power injector is receiving AC power and is ready to provide power to the access point.

Accessing the Console Port and the Reset Button

The access point has a console port and a reset button located on the left side of the enclosure, inside the Console-Reset port, under the hex-shaped sealed plug.



Caution

Inspect the seal of the plug and properly tighten it every time the plug is removed and replaced. Tighten the plug to 15 lbf-in.

Figure 3-3 Reset Button Location - Models AIR-CAP1552E-x-K9 and AIR-CAP1552EU-x-K9

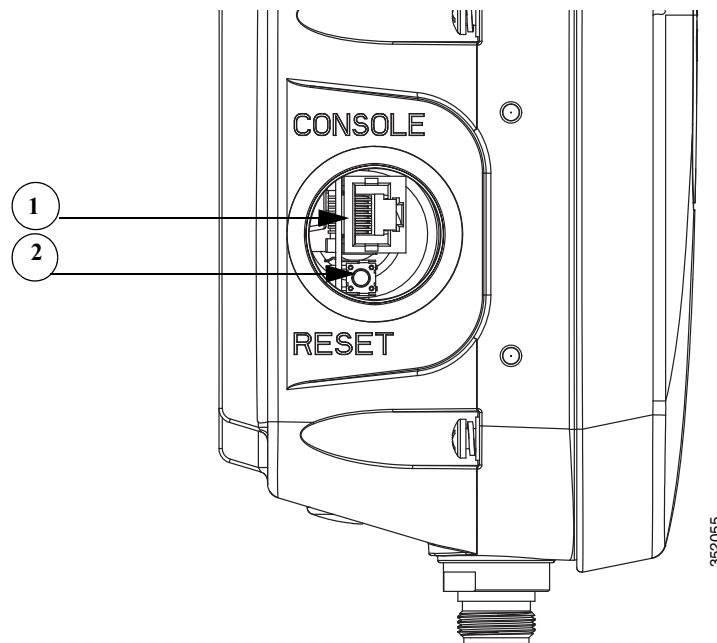

1	Console Port	2	Reset Button
---	--------------	---	--------------

Resetting the Access Point

Using the Reset button you can either return the AP back to its default factory-shipped configuration or download the latest software image from the default TFTP servers.

To use the Reset button:

-
- Step 1** Using a wrench, remove the hex-shaped plug from the Console-Reset port. Do not loose the seal around the plug.
- Step 2** To press and hold the Reset button, use a straightened paperclip or a small screwdriver or a pen.
- To reset the AP back to its default factory-shipped configuration, during power cycle, press and hold the Reset button (for about 2 to 3 seconds) until the LED blinks amber.
 - To download the software image (*ap1g3-k9w7-tar.default*) from the default TFTP servers (servers with IP address in the range of 10.0.0.2 to 10.0.0.30), during power cycle, press and hold the Reset button (for about 20 to 30 seconds) until the LED turns red.
- Step 3** Inspect the hex-shaped plug attached to the lanyard for any damage to the sealing face and the gasket. If the gasket has any signs of damage, it should be replaced to avoid water leakage into the unit.
- Step 4** Replace the hex-shaped plug back and tighten it to 15 lbf-in.
-



Translated Safety Warnings

For translated safety warnings, refer to the safety warning document that shipped with your access point or that is available on Cisco.com.

To browse to the document on Cisco.com, follow these steps:

-
- Step 1** Click this link and go to the Cisco Wireless documentation home page:
<http://www.cisco.com/en/US/products/hw/wireless/index.html>
 - Step 2** Click **Support** and the Support and Documentation page displays.
 - Step 3** Click **Wireless** in the Find Product Support column.
 - Step 4** Click **1530**.
 - Step 5** Click **Install and Upgrade**.
 - Step 6** Click **Install and Upgrade Guides**.
 - Step 7** Click **Translated Safety Warnings for Cisco Aironet 1530 Series Outdoor Mesh Access Points**.
-



Declarations of Conformity and Regulatory Information

This appendix provides declarations of conformity and regulatory information for the Cisco Aironet 1532 Outdoor Access Point.

This appendix contains the following sections:

- [Manufacturers Federal Communication Commission Declaration of Conformity Statement, page B-2](#)
- [Industry Canada, page B-3](#)
- [European Community, Switzerland, Norway, Iceland, and Liechtenstein, page B-6](#)
- [Declaration of Conformity for RF Exposure, page B-9](#)
- [Guidelines for Operating Cisco Aironet Access Points in Japan, page B-10](#)
- [VCCI Statement for Japan, page B-11](#)
- [Administrative Rules for Cisco Aironet Access Points in Taiwan, page B-11](#)
- [EU Declaration of Conformity, page B-14](#)

Manufacturers Federal Communication Commission Declaration of Conformity Statement



Models:	FCC Certification number:
AIR-CAP1532I-A-K9	LDK102090P
AIR-CAP1532I-B-K9	
AIR-CAP1532E-A-K9	LDK102089P
AIR-CAP1532E-B-K9	

Manufacturer:

Cisco Systems, Inc.
170 West Tasman Drive
San Jose, CA 95134-1706
USA

This device complies with Part 15 rules. Operation is subject to the following two conditions:

1. This device may not cause harmful interference, and
2. This device must accept any interference received, including interference that may cause undesired operation.

This equipment has been tested and found to comply with the limits of a Class A digital device, pursuant to Part 15 of the FCC Rules. These limits are designed to provide reasonable protection against harmful interference when the equipment is operated in a residential environment. This equipment generates, uses, and radiates radio frequency energy, and if not installed and used in accordance with the instructions, may cause harmful interference. However, there is no guarantee that interference will not occur. If this equipment does cause interference to radio or television reception, which can be determined by turning the equipment off and on, the user is encouraged to correct the interference by one of the following measures:

- Reorient or relocate the receiving antenna.
- Increase separation between the equipment and receiver.
- Connect the equipment to an outlet on a circuit different from which the receiver is connected.
- Consult the dealer or an experienced radio/TV technician.



Caution

The Part 15 radio device operates on a non-interference basis with other devices operating at this frequency when using Cisco-supplied antennas. Any changes or modification to the product not expressly approved by Cisco could void the user's authority to operate this device.

**Caution**

To meet regulatory restrictions, the access point must be professionally installed.

Requirements of operator to register the RLAN device operating Outdoors in the 5150 -5250 MHz band and addressing possible interference issues in this band

Section 15.407(j) of the rules established filing requirements for U-NII operators that deploy a collection of more than 1000 outdoor access points with the 5.15-5.25 GHz band, parties must submit a letter to the FCC lab acknowledging that, should harmful interference to licensed services in this band occur, they will be required to take corrective action. Corrective actions may include reducing power, turning off devices, changing frequency bands, and/or further reducing power radiated in the vertical direction.

This material shall be submitted to:

Federal Communications Commission
Laboratory Division, Office of Engineering and Technology
7435 Oakland Mills Road, Columbia, MD, 21046
Attn: U-NII Coordination

or via website at <https://www.fcc.gov/labhelp>
use subject line U-NII Filing

Industry Canada

Models:	IC Certification Number:
AIR-CAP1532I-A-K9	2461B-LDK102090P
AIR-CAP1532E-A-K9	2461B-LDK102089P

Canadian Compliance Statement

This device complies with Industry Canada licence-exempt RSS standard(s). Operation is subject to the following two conditions: (1) this device may not cause interference, and (2) this device must accept any interference, including interference that may cause undesired operation of the device.

Le présent appareil est conforme aux CNR d'Industrie Canada applicables aux appareils radio exempts de licence. L'exploitation est autorisée aux deux conditions suivantes : (1) l'appareil ne doit pas produire de brouillage, et (2) l'utilisateur de l'appareil doit accepter tout brouillage radioélectrique subi, même si le brouillage est susceptible d'en compromettre le fonctionnement.

Under Industry Canada regulations, this radio transmitter may only operate using an antenna of a type and maximum (or lesser) gain approved for the transmitter by Industry Canada. To reduce potential radio interference to other users, the antenna type and its gain should be so chosen that the equivalent isotropically radiated power (e.i.r.p.) is not more than that necessary for successful communication.

Conformément à la réglementation d'Industrie Canada, le présent émetteur radio peut fonctionner avec une antenne d'un type et d'un gain maximal (ou inférieur) approuvé pour l'émetteur par Industrie Canada. Dans le but de réduire les risques de brouillage radioélectrique à l'intention des autres utilisateurs, il faut choisir le type d'antenne et son gain de sorte que la puissance isotrope rayonnée équivalente (p.i.r.e.) ne dépasse pas l'intensité nécessaire à l'établissement d'une communication satisfaisante.

This radio transmitter has been approved by Industry Canada to operate with the antenna types listed below with the maximum permissible gain and required antenna impedance for each antenna type indicated. Antenna types not included in this list, having a gain greater than the maximum gain indicated for that type, are strictly prohibited for use with this device.

Le présent émetteur radio a été approuvé par Industrie Canada pour fonctionner avec les types d'antenne énumérés ci-dessous et ayant un gain admissible maximal et l'impédance requise pour chaque type d'antenne. Les types d'antenne non inclus dans cette liste, ou dont le gain est supérieur au gain maximal indiqué, sont strictement interdits pour l'exploitation de l'émetteur.

Antenna Type	Antenna Gain	Antenna Impedance
Dual-band Omni	3/5 dBi	50 ohms
Dual-band Omni	4/7 dBi	50 ohms
Dual-Band Directional	8/8 dBi	50 ohms
Single-Band Directional Patch	13/14 dBi	50 ohms

Operation in the band 5150-5250 MHz is only for indoor use to reduce the potential for harmful interference to co-channel mobile satellite systems.

La bande 5 150-5 250 MHz est réservés uniquement pour une utilisation à l'intérieur afin de réduire les risques de brouillage préjudiciable aux systèmes de satellites mobiles utilisant les mêmes canaux.

Users are advised that high-power radars are allocated as primary users (i.e. priority users) of the bands 5250-5350 MHz and 5650-5850 MHz and that these radars could cause interference and/or damage to LE-LAN devices.

Les utilisateurs êtes avisés que les utilisateurs de radars de haute puissance sont désignés utilisateurs principaux (c.-à-d., qu'ils ont la priorité) pour les bandes 5 250-5 350 MHz et 5 650-5 850 MHz et que ces radars pourraient causer du brouillage et/ou des dommages aux dispositifs LAN-EL

Declaration of Conformity for RF Exposure

This access point product has been found to be compliant to the requirements set forth in CFR 47 Section 1.1307 addressing RF Exposure from radio frequency devices as defined in Evaluating Compliance with FCC Guidelines for Human Exposure to Radio Frequency Electromagnetic Fields. Antennas that have 8 dBi to 14 dBi gain should be located at a minimum of 19.7 inches (50 cm) or more from the body of all persons. Antennas that have less than 8 dBi gain should be located at a minimum of 7.9 inches (20 cm) or more from the body of all persons.

This access point is also compliant to EN 50835 for RF exposure.

European Community, Switzerland, Norway, Iceland, and Liechtenstein

Access Point Models:

AIR-CAP1532I-E-K9

AIR-CAP1532E-E-K9

Declaration of Conformity with regard to the R&TTE Directive 1999/5/EC & Medical Directive 93/42/EEC

This declaration is only valid for configurations (combinations of software, firmware, and hardware) provided and supported by Cisco Systems. The use of software or firmware not provided and supported by Cisco Systems may result in the equipment no longer being compliant with the regulatory requirements.

Български [Bulgarian]:	Това оборудване отговаря на съществените изисквания и приложими клаузи на Директива 1999/5/EC.
Česky [Czech]:	Toto zařízení je v souladu se základními požadavky a ostatními odpovídajícími ustanoveními Směrnice 1999/5/EC.
Dansk [Danish]:	Dette udstyr er i overensstemmelse med de væsentlige krav og andre relevante bestemmelser i Direktiv 1999/5/EF.
Deutsch [German]:	Dieses Gerät entspricht den grundlegenden Anforderungen und den weiteren entsprechenden Vorgaben der Richtlinie 1999/5/EU.
Eesti [Estonian]:	See seade vastab direktiivi 1999/5/EÜ olulistele nõuetele ja teistele asjakohastele sätetele.
English:	This equipment is in compliance with the essential requirements and other relevant provisions of Directive 1999/5/EC.
Español [Spanish]:	Este equipo cumple con los requisitos esenciales así como con otras disposiciones de la Directiva 1999/5/CE.
Ελληνική [Greek]:	Αυτός ο εξοπλισμός είναι σε συμμόρφωση με τις ουσιώδεις απαιτήσεις και άλλες σχετικές διατάξεις της Οδηγίας 1999/5/EC.
Français [French]:	Cet appareil est conforme aux exigences essentielles et aux autres dispositions pertinentes de la Directive 1999/5/EC.
Íslenska [Icelandic]:	Þetta tæki er samkvæmt grunnkröfum og öðrum viðeigandi ákvæðum Tilskipunar 1999/5/EC.
Italiano [Italian]:	Questo apparato é conforme ai requisiti essenziali ed agli altri principi sanciti dalla Direttiva 1999/5/CE.
Latviešu [Latvian]:	Šī iekārta atbilst Direktīvas 1999/5/EK būtiskajām prasībām un citiem ar to saistītajiem noteikumiem.
Lietuvių [Lithuanian]:	Šis įrenginys tenkina 1999/5/EB Direktyvos esminius reikalavimus ir kitas šios direktyvos nuostatas.

142729

Nederlands [Dutch]:	Dit apparaat voldoet aan de essentiële eisen en andere van toepassing zijnde bepalingen van de Richtlijn 1999/5/EC.
Malti [Maltese]:	Dan l-apparat huwa konformi mal-htigiet essenzjali u l-provedimenti l-oħra rilevanti tad-Direttiva 1999/5/EC.
Magyar [Hungarian]:	Ez a készülék teljesíti az alapvető követelményeket és más 1999/5/EK irányelvben meghatározott vonatkozó rendelkezéseket.
Norsk [Norwegian]:	Dette utstyret er i samsvar med de grunnleggende krav og andre relevante bestemmelser i EU-direktiv 1999/5/EF.
Polski [Polish]:	Urządzenie jest zgodne z ogólnymi wymaganiami oraz szczególnymi warunkami określonymi Dyrektywą UE: 1999/5/EC.
Português [Portuguese]:	Este equipamento está em conformidade com os requisitos essenciais e outras provisões relevantes da Directiva 1999/5/EC.
Slovensko [Slovenian]:	Ta naprava je skladna z bistvenimi zahtevami in ostalimi relevantnimi pogoji Direktive 1999/5/EC.
Slovensky [Slovak]:	Toto zariadenie je v zhode so základnými požiadavkami a inými príslušnými nariadeniami direktiv: 1999/5/EC.
Suomi [Finnish]:	Tämä laite täyttää direktiivin 1999/5/EY olennaiset vaatimukset ja on siinä asetettujen muiden laitetta koskevien määräysten mukainen.
Svenska [Swedish]:	Denna utrustning är i överensstämmelse med de väsentliga kraven och andra relevanta bestämmelser i Direktiv 1999/5/EC.

121404

The following standards were applied:

- EMC—EN 301.489-1 v1.8.1; EN 301.489-17 v2.1.1
- Health & Safety—EN60950-1: 2005; EN 50385: 2002
- Radio—EN 300 328 v 1.7.1; EN 301.893 v 1.5.1

The conformity assessment procedure referred to in Article 10.4 and Annex III of Directive 1999/5/EC has been followed.

This device also conforms to the EMC requirements of the Medical Devices Directive 93/42/EEC.



Note

This equipment is intended to be used in all EU and EFTA countries. Outdoor use may be restricted to certain frequencies and/or may require a license for operation. For more details, contact Cisco Corporate Compliance.

The product carries the CE Mark:



Declaration of Conformity for RF Exposure

The following is the declaration of conformity for RF exposure for the United States, Canada, European Union and Australia.

United States

This system has been evaluated for RF exposure for Humans in reference to ANSI C 95.1 (American National Standards Institute) limits. The evaluation was based on ANSI C 95.1 and FCC OET Bulletin 65C rev 01.01. To maintain compliance, the minimum separation distance for antennas that have 8 dBi to 14 dBi gain, is 19.7 inches (50 cm) from general bystanders. The minimum separation distance from antennas that have less than 8 dBi gain to general bystanders is 7.9 inches (20 cm).

Canada

This system has been evaluated for RF exposure for Humans in reference to ANSI C 95.1 (American National Standards Institute) limits. The evaluation was based on RSS-102 Rev 2. To maintain compliance, the minimum separation distance for antennas that have 8 dBi to 14 dBi gain, is 19.7 inches (50 cm) from general bystanders. The minimum separation distance from antennas that have less than 8 dBi gain to general bystanders is 7.9 inches (20 cm).

European Union

This system has been evaluated for RF exposure for Humans in reference to the ICNIRP (International Commission on Non-Ionizing Radiation Protection) limits. The evaluation was based on the EN 50385 Product Standard to Demonstrate Compliance of Radio Base stations and Fixed Terminals for Wireless Telecommunications Systems with basic restrictions or reference levels related to Human Exposure to Radio Frequency Electromagnetic Fields from 300 MHz to 40 GHz. To maintain compliance, the minimum separation distance for antennas that have 8 dBi to 14 dBi gain, is 19.7 inches (50 cm) from general bystanders. The minimum separation distance from antennas that have less than 8 dBi gain to general bystanders is 7.9 inches (20 cm).

Australia

This system has been evaluated for RF exposure for Humans as referenced in the Australian Radiation Protection standard and has been evaluated to the ICNIRP (International Commission on Non-Ionizing Radiation Protection) limits. To maintain compliance, the minimum separation distance for antennas that have 8 dBi to 14 dBi gain, is 19.7 inches (50 cm) from general bystanders. The minimum separation distance from antennas that have less than 8 dBi gain to general bystanders is 7.9 inches (20 cm).

Guidelines for Operating Cisco Aironet Access Points in Japan

This section provides guidelines for avoiding interference when operating Cisco Aironet access points in Japan. These guidelines are provided in both Japanese and English.

Access Point Model:

AIR-CAP1532E-Q-K9

AIR-CAP1532I-Q-K9

Japanese Translation

この機器の使用周波数帯では、電子レンジ等の産業・科学・医療用機器のほか工場の製造ライン等で使用されている移動体識別用の構内無線局（免許を要する無線局）及び特定小電力無線局（免許を要しない無線局）が運用されています。

- 1 この機器を使用する前に、近くで移動体識別用の構内無線局及び特定小電力無線局が運用されていないことを確認して下さい。
- 2 万一、この機器から移動体識別用の構内無線局に対して電波干渉の事例が発生した場合には、速やかに使用周波数を変更するか又は電波の発射を停止した上、下記連絡先にご連絡頂き、混信回避のための処置等(例えば、パーティションの設置など)についてご相談して下さい。
- 3 その他、この機器から移動体識別用の特定小電力無線局に対して電波干渉の事例が発生した場合など何かお困りのことが起きたときは、次の連絡先へお問い合わせ下さい。

連絡先 : 03-6434-6500

43768

English Translation

This equipment operates in the same frequency bandwidth as industrial, scientific, and medical devices such as microwave ovens and mobile object identification (RF-ID) systems (licensed premises radio stations and unlicensed specified low-power radio stations) used in factory production lines.

1. Before using this equipment, make sure that no premises radio stations or specified low-power radio stations of RF-ID are used in the vicinity.
2. If this equipment causes RF interference to a premises radio station of RF-ID, promptly change the frequency or stop using the device; contact the number below and ask for recommendations on avoiding radio interference, such as setting partitions.
3. If this equipment causes RF interference to a specified low-power radio station of RF-ID, contact the number below.

Contact Number: 03-6434-6500

VCCI Statement for Japan



This is a Class B product based on the standard of the Voluntary Control Council for Interference from Information Technology Equipment (VCCI). If this is used near a radio or television receiver in a domestic environment, it may cause radio interference. Install and use the equipment according to the instruction manual.

警告

この装置は、クラスB情報技術装置です。この装置は、家庭環境で使用することを目的としていますが、この装置がラジオやテレビジョン受信機に近接して使用されると、受信障害を引き起こすことがあります。
取扱説明書に従って正しい取り扱いをして下さい。

V C C I - B

Administrative Rules for Cisco Aironet Access Points in Taiwan

This section provides administrative rules for operating Cisco Aironet Access Points in Taiwan. The rules are provided in both Chinese and English.

Chinese Translation

低功率電波輻射性電機管理辦法

第十二條 經型式認證合格之低功率射頻電機，非經許可，公司、商號或使用者均不得擅自變更頻率、加大功率或變更原設計之特性及功能。

第十四條 低功率射頻電機之使用不得影響飛航安全及干擾合法通信；經發現有干擾現象時，應立即停用，並改善至無干擾時方得繼續使用。

前項合法通信，指依電信法規定作業之無線電信。

低功率射頻電機須忍受合法通信或工業、科學及醫療用電波輻射性電機設備之干擾。

127048

English Translation

Administrative Rules for Low-power Radio-Frequency Devices

Article 12

For those low-power radio-frequency devices that have already received a type-approval, companies, business units or users should not change its frequencies, increase its power or change its original features and functions.

Article 14

The operation of the low-power radio-frequency devices is subject to the conditions that no harmful interference is caused to aviation safety and authorized radio station; and if interference is caused, the user must stop operating the device immediately and can't re-operate it until the harmful interference is clear.

The authorized radio station means a radio-communication service operating in accordance with the Communication Act.

The operation of the low-power radio-frequency devices is subject to the interference caused by the operation of an authorized radio station, by another intentional or unintentional radiator, by industrial, scientific and medical (ISM) equipment, or by an incidental radiator.

Chinese Translation

低功率射頻電機技術規範

4.7 無線資訊傳輸設備

4.7.6 無線資訊傳輸設備須忍受合法通信之干擾且不得干擾合法通信；如造成干擾，應立即停用，俟無干擾之虞，始得繼續使用。

4.7.7 無線資訊傳輸設備的製造廠商應確保頻率穩定性，如依製造廠商使用手冊上所述正常操作，發射的信號應維持於操作頻帶中。

2009139

English Translation

Low-power Radio-frequency Devices Technical Specifications

4.7

Unlicensed National Information Infrastructure

4.7.6

The U-NII devices shall accept any interference from legal communications and shall not interfere the legal communications. If interference is caused, the user must stop operating the device immediately and can't re-operate it until the harmful interference is clear.

4.7.7

Manufacturers of U-NII devices are responsible for ensuring frequency stability such that an emission is maintained within the band of operation under all conditions of normal operation as specified in the user manual.

Statement 371—Power Cable and AC Adapter

接続ケーブル、電源コード、ACアダプタ、バッテリーなどの部品は、必ず添付品または指定品をご使用ください。添付品・指定品以外の部品をご使用になると故障や動作不良、火災の原因となります。また、電気用品安全法により、当該法の認定（PSEとコードに表記）でなくUL認定（ULまたはCSAマークがコードに表記）の電源ケーブルは弊社が指定する製品以外の電気機器には使用できないためご注意ください。

English Translation

When installing the product, please use the provided or designated connection cables/power cables/AC adapters. Using any other cables/adapters could cause a malfunction or a fire. Electrical Appliance and Material Safety Law prohibits the use of UL-certified cables (that have the “UL” shown on the code) for any other electrical devices than products designated by CISCO. The use of cables that are certified by Electrical Appliance and Material Safety Law (that have “PSE” shown on the code) is not limited to CISCO-designated products.

EU Declaration of Conformity

All the Declaration of Conformity statements related to this product can be found at the following location:

<http://www.ciscofax.com>

Operation of Cisco Aironet Access Points in Brazil

This section contains special information for operation of Cisco Aironet access points in Brazil.

Access Point Models

AIR-CAP1532E-Z-K9

AIR-CAP1532I-Z-K9

Regulatory Information

Figure B-1 contains Brazil regulatory information for the access point models identified in the previous section.

Figure B-1 Brazil Regulatory Information



Portuguese Translation

Este equipamento opera em caráter secundário, isto é, não tem direito a proteção contra interferência prejudicial, mesmo de estações do mesmo tipo, e não pode causar interferência a sistemas operando em caráter primário.

English Translation

This equipment operates on a secondary basis and consequently must accept harmful interference, including interference from stations of the same kind. This equipment may not cause harmful interference to systems operating on a primary basis.



Channels and Power Levels

For channel and maximum power level settings, refer to the *Channels and Maximum Power Settings for Cisco Aironet Lightweight Access Points and Bridges* document available on the Cisco Wireless documentation page of Cisco.com.

To browse to the document, follow these steps:

-
- Step 1** Click this link and go to the Cisco Wireless documentation home page:
<http://www.cisco.com/en/US/products/hw/wireless/index.html>
 - Step 2** Click **Support**. The Support and Documentation page displays.
 - Step 3** Click **Wireless**
 - Step 4** Click **1530**.
 - Step 5** Click **Install and Upgrade**.
 - Step 6** Click **Install and Upgrade Guides**.
 - Step 7** Click **Channels and Maximum Power Settings for Cisco 1530 Series Outdoor Access Points** document.
-



Access Point Data Sheet

The detailed technical specifications for the Cisco Aironet 1530 Series Outdoor Access Points are available at the following URL:

http://www.cisco.com/en/US/prod/collateral/wireless/ps5679/ps12831/data_sheet_c78-728356.html

You can also download a copy of the *Cisco Aironet 1530 Series Outdoor Access Point Data Sheet* from the above URL for offline use.



Access Point Pinouts

This appendix describes the pin signals of the access point Ethernet connectors, and the power injector input and output connectors.

[Table E-1](#) describes the pin signals of the access point LAN connector

Table E-1 *Access Point LAN Connector Pinouts*

Pin Number	Signal Name
1	Ethernet signal pair (10/100/1000BASE-T)
2	
3	Ethernet signal pair (10/100/1000BASE-T)
6	
4	Ethernet signal pair (10/100/1000BASE-T)
5	
7	Ethernet signal pair (10/100/1000BASE-T)
8	
Shield	Chassis ground

[Table E-2](#) describes the pin signals for the access point PoE-in Ethernet connector. The Pinouts given in this table are applicable to AIR-POWERINJ1500. Not all PoE power sources follow these pinouts.

Table E-2 *Access Point PoE-In Ethernet Connector Pinouts for AIR-POWERINJ1500*

Pin Number	Signal Name
1	Ethernet signal pair (10/100/1000BASE-T) and DC return
2	
3	Ethernet signal pair (10/100/1000BASE-T) and DC (+)
6	
4	Ethernet signal pair (1000BASE-T) and DC (+)
5	

Table E-2 Access Point PoE-In Ethernet Connector Pinouts for AIR-POWERINJ1500

Pin Number	Signal Name
7	Ethernet signal pair (1000BASE-T) and DC return
8	
Shield	Chassis ground

Table E-3 describes the pin signals for the power injector input connector (To Switch).

Table E-3 Power Injector Input Connector (To Switch) Pinouts

Pin Number	Signal Name
1	Ethernet signal pair (10/100/1000BASE-T)
2	
3	Ethernet signal pair 10/100/1000BASE-T)
6	
4	Ethernet signal pair (1000BASE-T)
5	
7	Ethernet signal pair (1000BASE-T)
8	
Shield	Chassis ground

Table E-4 describes the RJ-45 pin signals for the power injector output connector (To AP). The Pinouts given in this table are applicable to AIR-POWERINJ1500. Not all PoE power sources follow these pinouts.

Table E-4 Power Injector AIR-POWERINJ1500 Output Connector (To AP) Pinouts

Pin Number	Signal Name
1	Ethernet signal pair (10/100/1000BASE-T) and DC return
2	
3	Ethernet signal pair (10/100/1000BASE-T) and DC (+)
6	
4	Ethernet signal pair (1000BASE-T) and DC (+)
5	
7	Ethernet signal pair (1000BASE-T) and DC return
8	
Shield	Chassis ground



Configuring DHCP Option 43

For information on how to configure how to use DHCP Option 43 and to see sample configurations for DHCP Option 43 for lightweight Cisco Aironet access points (LAPs), go to the following URL:

<http://www.cisco.com/c/en/us/support/docs/wireless-mobility/wireless-lan-wlan/97066-dhcp-option-43-00.html>



- 802.3af/at** The IEEE standard that describes a mechanism for Power over Ethernet (PoE). The standard provides the capability to deliver both power and data over standard Ethernet cabling.
- 802.11** The IEEE standard that specifies carrier sense media access control and physical layer specifications for 1- and 2-megabit-per-second (Mb/s) wireless LANs operating in the 2.4-GHz band.
- 802.11a** The IEEE standard that specifies carrier sense media access control and physical layer specifications for wireless LANs operating in the 5-GHz frequency band.
- 802.11b** The IEEE standard that specifies carrier sense media access control and physical layer specifications for 5.5- and 11-Mb/s wireless LANs operating in the 2.4-GHz frequency band.
- 802.11g** The IEEE standard that specifies carrier sense media access control and physical layer specifications for 6, 9, 12, 18, 24, 36, 48, and 54 Mb/s wireless LANs operating in the 2.4-GHz frequency band.
- 802.11n** 802.11n is a specification for wireless LAN (WLAN) communications. An addition to the 802.11 family of standards, 802.11n increases network speed and reliability and extends the operating distance of wireless networks. Raw data throughput is expected to reach as much as 600 Mb/s, or more than 10 times the throughput of 802.11g

A

- access point** A wireless LAN data transceiver that uses radio waves to connect a wired network with wireless stations.
- ad hoc network** A wireless network composed of stations without access points.
- antenna gain** The gain of an antenna is a measure of the antenna ability to direct or focus radio energy over a region of space. High gain antennas have a more focused radiation pattern in a specific direction.
- associated** A station is configured properly to allow it to wirelessly communicate with an access point.
- AWPP** Adaptive Wireless Path Protocol.

B

beacon	A wireless LAN packet that signals the availability and presence of the wireless device. Beacon packets are sent by access points and base stations; however, client radio cards send beacons when operating in computer to computer (Ad Hoc) mode.
BOOTP	Boot Protocol. A protocol used for the static assignment of IP addresses to devices on the network.
BPSK	Binary phase shift keying is a modulation technique used by IEEE 802.11b-compliant wireless LANs for transmission at 1 Mb/s.
broadcast packet	A single data message (packet) sent to all addresses on the same subnet.

C

CAPWAP	Control And Provisioning of Wireless Access Points
CCK	Complementary Code Keying. A modulation technique used by IEEE 802.11b-compliant wireless LANs for transmission at 5.5 and 11 Mb/s.
CCKM	Cisco Centralized Key Management. Using CCKM, authenticated client devices can roam from one access point to another without any perceptible delay during reassociation. An access point on your network provides wireless domain services (WDS) and creates a cache of security credentials for CCKM-enabled client devices on the subnet. The WDS access point's cache of credentials dramatically reduces the time required for reassociation when a CCKM-enabled client device roams to a new access point.
cell	The area of radio range or coverage in which the wireless devices can communicate with the base station. The size of the cell depends upon the speed of the transmission, the type of antenna used, and the physical environment, as well as other factors.
client	A radio device that uses the services of an access point to communicate wirelessly with other devices on a local area network.
CSMA	Carrier sense multiple access. A wireless LAN media access method specified by the IEEE 802.11 specification.

D

data rates	The range of data transmission rates supported by a device. Data rates are measured in megabits per second (Mb/s).
dBi	A ratio of decibels to an isotropic antenna that is commonly used to measure antenna gain. The greater the dBi value, the higher the gain, and the more acute the angle of coverage.

DFS	Dynamic Frequency Selection. In some regulatory domains, 5-GHz radios are required to use DFS to avoid interfering with radar signals.
DHCP	Dynamic host configuration protocol. A protocol available with many operating systems that automatically issues IP addresses within a specified range to devices on the network. The device retains the assigned address for a specific administrator-defined period.
domain name	The text name that refers to a grouping of networks or network resources based on organization-type or geography; for example: name.com—commercial; name.edu—educational; name.gov—government; ISPname.net—network provider (such as an ISP); name.ar—Argentina; name.au—Australia; and so on.
DNS	Domain Name System server. A server that translates text names into IP addresses. The server maintains a database of host alphanumeric names and their corresponding IP addresses.
DSSS	Direct sequence spread spectrum. A type of spread spectrum radio transmission that spreads its signal continuously over a wide frequency band.

E

EAP	Extensible Authentication Protocol. An optional IEEE 802.1x security feature ideal for organizations with a large user base and access to an EAP-enabled Remote Authentication Dial-In User Service (RADIUS) server.
Ethernet	The most widely used wired local area network. Ethernet uses carrier sense multiple access (CSMA) to allow computers to share a network and operates at 10, 100, or 1000 Mb/s, depending on the physical layer used.

F

file server	A repository for files so that a local area network can share files, mail, and programs.
firmware	Software that is programmed on a memory chip.

G

gateway	A device that connects two otherwise incompatible networks together.
GHz	Gigahertz. One billion cycles per second. A unit of measure for frequency.

I

IEEE	Institute of Electrical and Electronic Engineers. A professional society serving electrical engineers through its publications, conferences, and standards development activities. The body responsible for the Ethernet 802.3 and wireless LAN 802.11 specifications.
infrastructure	The wired Ethernet network.
IP address	The Internet Protocol (IP) address of a station.
IP subnet mask	The number used to identify the IP subnetwork, indicating whether the IP address can be recognized on the LAN or if it must be reached through a gateway. This number is expressed in a form similar to an IP address; for example: 255.255.255.0.
isotropic	An antenna that radiates its signal in a spherical pattern.

M

MAC address	Media Access Control address. A unique 48-bit number used in Ethernet data packets to identify an Ethernet device, such as an access point or your client adapter.
MAP	Mesh Access Point
MBSSID	Multiple basic SSID. Each multiple basic SSID is assigned a unique MAC address. You use multiple BSSIDs to assign a unique DTIM setting for each SSID and to broadcast SSIDs in beacons (one SSID per beacon).
MIMO	Multiple Input/Multiple Output
modulation	Any of several techniques for combining user information with a transmitter for a carrier signal.
multipath	The echoes created as a radio signal bounces off of physical objects.
multicast packet	A single data message (packet) sent to multiple addresses.

O

- omni-directional** This typically refers to a primarily circular antenna radiation pattern.
- OFDM** Orthogonal frequency division multiplex is a modulation technique used by IEEE 802.11a-compliant wireless LANs for transmission at 6, 9, 12, 18, 24, 36, 48, and 54 Mb/s.

P

- packet** A basic message unit for communication across a network. A packet usually includes routing information, data, and sometimes error detection information.

Q

- QPSK** Quadruple phase shift keying is a modulation technique used by IEEE 802.11b-compliant wireless LANs for transmission at 2 Mb/s.

R

- range** A linear measure of the distance that a transmitter can send a signal.
- RAP** Root Access Point
- receiver sensitivity** A measurement of the weakest signal a receiver can receive and still correctly translate it into data.
- RF** Radio frequency. A generic term for radio-based technology.
- roaming** A feature of some access points that allows users to move through a facility while maintaining an unbroken connection to the LAN.
- RP-TNC** A connector type unique to Cisco Aironet radios and antennas. Part 15.203 of the FCC rules covering spread spectrum devices limits the types of antennas that may be used with transmission equipment. In compliance with this rule, Cisco Aironet, like all other wireless LAN providers, equips its radios and antennas with a unique connector to prevent attachment of non-approved antennas to radios.

S

spread spectrum A radio transmission technology that spreads the user information over a much wider bandwidth than otherwise required in order to gain benefits such as improved interference tolerance and unlicensed operation.

SSID Service set identifier (also referred to as Radio Network Name). A unique identifier used to identify a radio network and which stations must use to be able to communicate with each other or to an access point. The SSID can be any alphanumeric entry up to a maximum of 32 characters.

T

transmit power The power level of radio transmission.

U

UNII Unlicensed National Information Infrastructure—regulations for UNII devices operating in the 5.15 to 5.35 GHz and 5.725 to 5.825 GHz frequency bands.

UNII-1 Regulations for UNII devices operating in the 5.15 to 5.25 GHz frequency band.

UNII-2 Regulations for UNII devices operating in the 5.25 to 5.35 GHz frequency band.

UNII-3 Regulations for UNII devices operating in the 5.725 to 5.825 GHz frequency band.

unicast packet A single data message (packet) sent to a specific IP address.

UPoE Cisco Universal Power Over Ethernet (UPOE) extends IEEE PoE+ standard by doubling the power per port to 60W over a single standard Ethernet Cable. It allows the consolidation of 60 watts power on a single Ethernet (CAT5E or higher) cable, or in short 60W per access switch port.

W

WDS Wireless Domain Services. An access point providing WDS on your wireless LAN maintains a cache of credentials for CCKM-capable client devices on your wireless LAN. When a CCKM-capable client roams from one access point to another, the WDS access point forwards the client's credentials to the new access point with the multicast key. Only two packets pass between the client and the new access point, greatly shortening the reassociation time.

WEP Wired Equivalent Privacy. An optional security mechanism defined within the 802.11 standard designed to make the link integrity of wireless devices equal to that of a cable.

WLSE	Wireless LAN Solutions Engine. The WLSE is a specialized appliance for managing Cisco Aironet wireless LAN infrastructures. It centrally identifies and configures access points in customer-defined groups and reports on throughput and client associations. WLSE's centralized management capabilities are further enhanced with an integrated template-based configuration tool for added configuration ease and improved productivity.
WNM	Wireless Network Manager.
workstation	A computing device with an installed client adapter.
WPA	Wi-Fi Protected Access is a standards-based, interoperable security enhancement that strongly increases the level of data protection and access control for existing and future wireless LAN systems. It is derived from and will be forward-compatible with the upcoming IEEE 802.11i standard. WPA leverages TKIP (Temporal Key Integrity Protocol) for data protection and 802.1X for authenticated key management.