



ADC Administration Guide, StarOS Release 21.13

First Published: 2019-03-28

Americas Headquarters

Cisco Systems, Inc.
170 West Tasman Drive
San Jose, CA 95134-1706
USA
<http://www.cisco.com>
Tel: 408 526-4000
800 553-NETS (6387)
Fax: 408 527-0883

THE SPECIFICATIONS AND INFORMATION REGARDING THE PRODUCTS IN THIS MANUAL ARE SUBJECT TO CHANGE WITHOUT NOTICE. ALL STATEMENTS, INFORMATION, AND RECOMMENDATIONS IN THIS MANUAL ARE BELIEVED TO BE ACCURATE BUT ARE PRESENTED WITHOUT WARRANTY OF ANY KIND, EXPRESS OR IMPLIED. USERS MUST TAKE FULL RESPONSIBILITY FOR THEIR APPLICATION OF ANY PRODUCTS.

THE SOFTWARE LICENSE AND LIMITED WARRANTY FOR THE ACCOMPANYING PRODUCT ARE SET FORTH IN THE INFORMATION PACKET THAT SHIPPED WITH THE PRODUCT AND ARE INCORPORATED HEREIN BY THIS REFERENCE. IF YOU ARE UNABLE TO LOCATE THE SOFTWARE LICENSE OR LIMITED WARRANTY, CONTACT YOUR CISCO REPRESENTATIVE FOR A COPY.

The Cisco implementation of TCP header compression is an adaptation of a program developed by the University of California, Berkeley (UCB) as part of UCB's public domain version of the UNIX operating system. All rights reserved. Copyright © 1981, Regents of the University of California.

NOTWITHSTANDING ANY OTHER WARRANTY HEREIN, ALL DOCUMENT FILES AND SOFTWARE OF THESE SUPPLIERS ARE PROVIDED "AS IS" WITH ALL FAULTS. CISCO AND THE ABOVE-NAMED SUPPLIERS DISCLAIM ALL WARRANTIES, EXPRESSED OR IMPLIED, INCLUDING, WITHOUT LIMITATION, THOSE OF MERCHANTABILITY, FITNESS FOR A PARTICULAR PURPOSE AND NON-INFRINGEMENT OR ARISING FROM A COURSE OF DEALING, USAGE, OR TRADE PRACTICE.

IN NO EVENT SHALL CISCO OR ITS SUPPLIERS BE LIABLE FOR ANY INDIRECT, SPECIAL, CONSEQUENTIAL, OR INCIDENTAL DAMAGES, INCLUDING, WITHOUT LIMITATION, LOST PROFITS OR LOSS OR DAMAGE TO DATA ARISING OUT OF THE USE OR INABILITY TO USE THIS MANUAL, EVEN IF CISCO OR ITS SUPPLIERS HAVE BEEN ADVISED OF THE POSSIBILITY OF SUCH DAMAGES.

Any Internet Protocol (IP) addresses and phone numbers used in this document are not intended to be actual addresses and phone numbers. Any examples, command display output, network topology diagrams, and other figures included in the document are shown for illustrative purposes only. Any use of actual IP addresses or phone numbers in illustrative content is unintentional and coincidental.

All printed copies and duplicate soft copies of this document are considered uncontrolled. See the current online version for the latest version.

Cisco has more than 200 offices worldwide. Addresses and phone numbers are listed on the Cisco website at www.cisco.com/go/offices.

Cisco and the Cisco logo are trademarks or registered trademarks of Cisco and/or its affiliates in the U.S. and other countries. To view a list of Cisco trademarks, go to this URL: [www.cisco.com go trademarks](http://www.cisco.com/go/trademarks). Third-party trademarks mentioned are the property of their respective owners. The use of the word partner does not imply a partnership relationship between Cisco and any other company. (1721R)

© 2019 Cisco Systems, Inc. All rights reserved.



CONTENTS

PREFACE

About this Guide	vii
Conventions Used	vii
Supported Documents and Resources	viii
Related Common Documentation	viii
Related Product Documentation	viii
Obtaining Documentation	ix
Contacting Customer Support	ix

CHAPTER 1

Application Detection and Control Overview	1
ADC Overview	1
Qualified Platforms	2
License Requirements	2
Dynamic Software Upgrade	2
Overview	2
ADC Protocol Group Detection	3
Behavioral Traffic	4
SNI Detection	4
SSL Renegotiation Tracking	4
Analyzer Interworking	5
Traffic Sub-classification	5
ADC Support for TRM/FP	5
ADC Support for FAPA	5
ADC Support over Gx	7
Limitations	9
Dynamic Advertisement Server Correlation	9
Bulk Statistics Support	10

How ADC Works 11
 Limitations 11

CHAPTER 2

Application Detection and Control Configuration 13
 Configuring Dynamic Software Upgrade 13
 How to perform Dynamic Software Upgrade 13
 Configuring System for ADC 15
 Initial Configuration 16
 Enabling Enhanced Charging 16
 Modifying the Local Context 16
 ADC Configuration 17
 Creating the Active Charging Service 17
 Configuring ADC Rules 18
 Configuring P2P Protocol Groups 19
 Configuring Behavioral Detection 20
 Configuring P2P Advertisement server 21
 Configuring SSL Renegotiation 21
 Configuring Analyzers 22
 Configuring the Charging Action 22
 Configuring the Rulebase 23
 Setting EDR Formats 24
 Configuring IP Protocol and Server port mapping 24
 Configuring EDR for P2P Events 25
 Gathering ADC Statistics 26
 Supported Bulk Statistics 27
 P2P Reports 27

CHAPTER 3

App-based Tethering Detection 29
 Feature Information 29
 Feature Description 30
 How It Works 30
 Licensing 30
 Configuring App-based Tethering Detection 30
 Enabling App-based Tethering Detection at Rulebase Level 30

Enabling App-based Tethering Detection at Ruledef Level	31
Enabling App-based Tethering Detection at Rule-variable	31
Monitoring and Troubleshooting the App-based Tethering Detection	32
Show Commands and Outputs	32

CHAPTER 4 **Peer-to-Peer Protocol and Application Detection Support** 35

Supported Protocols and Applications	35
New in this Release	35
All Supported Protocols and Applications	36
Port-based Protocols	104
IP Protocols	132

CHAPTER 5 **Reporting SSL Parameters in EDR** 139

Feature Summary and Revision History	139
Feature Description	140
How It Works	140
EDR	140
Configuring SSL Parameters in EDR	142
Enabling SSL Parameters	142
Monitoring and Troubleshooting	142
Show Commands and/or Outputs	142

CHAPTER 6 **Support for SNI Detection** 145

Feature Description	145
QUIC SNI Detection	145
Relationships to Other Features	146
Configuring SNI Detection	147
Configuring SNI in Ruledef	147
Configuring SNI rule variable	148
Enabling HTTPS Analyzer Interworking	149
Verifying the SNI Configuration	149
Monitoring and Troubleshooting the SNI Detection	149
SNI Detection Show Command(s) and/or Outputs	149
show active-charging analyzer statistics name cdp	149

[show active-charging flows type cdp](#) 150

[Bulk Statistics](#) 150



About this Guide

This preface describes the *ADC Administration Guide*, how it is organized and its document conventions.

Application Detection and Control (ADC) is a StarOS™ in-line service application that runs on Cisco® ASR 5500 platform.

The ADC in-line service makes use of innovative and highly accurate protocol behavioral detection techniques to reliably detect protocols and applications in the network. ADC is mainly used to detect Peer-to-Peer protocols by analyzing traffic, and can also detect network traffic created by audio and video clients.

- [Conventions Used, on page vii](#)
- [Supported Documents and Resources, on page viii](#)
- [Contacting Customer Support , on page ix](#)

Conventions Used

The following tables describe the conventions used throughout this documentation.

Notice Type	Description
Information Note	Provides information about important features or instructions.
Caution	Alerts you of potential damage to a program, device, or system.
Warning	Alerts you of potential personal injury or fatality. May also alert you of potential electrical hazards.

Typeface Conventions	Description
Text represented as a screen display	This typeface represents displays that appear on your terminal screen, for example: Login:

Typeface Conventions	Description
Text represented as commands	This typeface represents commands that you enter, for example: show ip access-list This document always gives the full form of a command in lowercase letters. Commands are not case sensitive.
Text represented as a command variable	This typeface represents a variable that is part of a command, for example: show card slot_number <i>slot_number</i> is a variable representing the desired chassis slot number.
Text represented as menu or sub-menu names	This typeface represents menus and sub-menus that you access within a software application, for example: Click the File menu, then click New

Supported Documents and Resources

Related Common Documentation

The following common documents are available:

- *AAA Interface Administration and Reference*
- *Command Line Interface Reference*
- *GTPP Interface Administration and Reference*
- *Installation Guide* (platform dependant)
- *Release Change Reference*
- *SNMP MIB Reference*
- *Statistics and Counters Reference*
- *System Administration Guide* (platform dependant)
- *Thresholding Configuration Guide*

Related Product Documentation

The most up-to-date information for this product is available in the product Release Notes provided with each product release.

The following product documents are also available and work in conjunction with ADC:

- *ECS Administration Guide*
- *GGSN Administration Guide*
- *PDSN Administration Guide*
- *P-GW Administration Guide*

Obtaining Documentation

The most current Cisco documentation is available on the following website:

<http://www.cisco.com/cisco/web/psa/default.html>

Use the following path selections to access the ADC documentation:

Products > Wireless > Mobile Internet > In-Line Services > Cisco Peer-to-Peer

Contacting Customer Support

Use the information in this section to contact customer support.

Refer to the support area of <http://www.cisco.com> for up-to-date product documentation or to submit a service request. A valid username and password are required to access this site. Please contact your Cisco sales or service representative for additional information.



CHAPTER 1

Application Detection and Control Overview

This chapter provides an overview of the Application Detection and Control (ADC) in-line service, formerly known as Peer-to-Peer Detection.

The System Administration Guide provides basic system configuration information, and the product administration guides provide procedures to configure basic functionality of core network service. It is recommended that you select the configuration example that best meets your service model, and configure the required elements for that model, as described in the respective product Administration Guide, before using the procedures in this chapter.

This chapter covers the following topics:

- [ADC Overview, on page 1](#)
- [How ADC Works, on page 11](#)

ADC Overview

The ADC in-line service is mainly used to detect Peer-to-Peer protocols by analyzing traffic. Other popular applications that generate the bulk of Internet traffic like Social Networking and Gaming applications can be detected.

The ADC in-line service works in conjunction with the following products:

- GGSN
- PDSN
- P-GW

The in-line service now known as ADC is continued to be referred as "P2P" in the configuration.

Peer to Peer (P2P) is a term used in two slightly different contexts. At a functional level, it means protocols that interact in a peering manner, in contrast to client-server manner. There is no clear differentiation between the function of one node or another. Any node can function as a client, a server, or both — a protocol may not clearly differentiate between the two. For example, peering exchanges may simultaneously include client and server functionality, sending and receiving information. P2P is a type of transient Internet network that allows a group of computer users with the same networking program to connect with each other and directly access files from one another's hard drives. A common use case of a P2P application is file sharing.

Once the P2P Client is downloaded and installed, it will log on to a central indexing server. This central server indexes all users who are currently online connected to the server. This server does not host any files for downloading. The P2P client can search for a specific file. The utility queries the index server to find other connected users with the specific file. When a match is found, the central server directs to find the requested

file. The result is chosen from the search query and the utility will then attempt to establish a connection with the computer hosting the requested file. If a successful connection is made, it will begin downloading the file. Once the file download is complete, the connection will be broken.

The stunning growth and intensive bandwidth nature of P2P applications can have a significant impact on the underlying network. As most deployments are designed with a significant bias towards downstream traffic, P2P applications stress uplink capacity resulting in increased latency, decreased responsiveness and packet loss.

To avoid detection, P2P software undergoes frequent changes and this requires service providers to upgrade the software with the latest P2P detection logic. This upgrade is time consuming, also causing disruption in services and revenue loss. The Dynamic Software Upgrade (DSU) addresses these problems by enabling operators to upgrade their detection capabilities with no downtime. The detection logic is separated out from the main code and shipped as a plugin. Whenever there is a need for software upgrade, the new plugin will be shipped and loaded into the system. For more information, refer to the *Dynamic Software Upgrade* section.

Qualified Platforms

ADC is a StarOS in-line service application that runs on Cisco ASR 5500 platforms. For additional platform information, refer to the appropriate System Administration Guide and/or contact your Cisco account representative.

License Requirements

The ADC is a licensed Cisco feature. A separate feature license may be required. Contact your Cisco account representative for detailed information on specific licensing requirements. For information on installing and verifying licenses, refer to the *Managing License Keys* section of the *Software Management Operations* chapter in the *System Administration Guide*.

Dynamic Software Upgrade

This section describes the Dynamic Software Upgrade (DSU) process that can be used to dynamically update plugins without having to update StarOS and reload the system.

Overview

Dynamic Software Upgrade is the new approach to upgrade the P2P library version that will enable operators to upgrade their detection capabilities with no downtime. This is done by providing updates in the form of software patches which the operator can apply in a live setup with minimal interference.

In this approach, P2P detection code is now delivered as a plugin within the StarOS binary. The plugin is loaded into the system at run time. Whenever there is a change in P2P detection logic of an existing application or a new P2P protocol/application needs to be added, a new version of the plugin is provided as a plugin module. The new plugin is loaded onto the system dynamically without disrupting other services. Once the plugin has been installed and configured, the new P2P rules come into effect for detection.



Important

The dynamically loaded plugins are not incremental. A plugin loads protocol detection logic for all the protocols/applications. A user can update to a higher priority plugin or rollback to a lower priority plugin.

Patching is the process used to install a plugin as an update to a StarOS release. One patch can be provided to multiple compatible, concurrent product releases. A plugin patch is distributed in the form of a compressed distribution kit through the internet or by other means (USB, CD, etc.).

A plugin is a functional software entity that provides updates to a pre-existing StarOS software component. Plugins can be dynamically loaded at runtime and do not require a system restart.

A plugin module is a specific instance of a plugin version consisting of at least one file that can be added to a running, in-service system. The module contains the information or instructions for a specific component's update. Typically this will be a single plugin file.

The Version Priority List (VPL) is a linked list of module versions associated with a specific plugin. Each plugin has one VPL. The list is sorted in ascending order by the priority number that is assigned by the administrator. When updating, the lowest priority number is loaded first and if that version is not successful, the version in the VPL with the next sequentially greater priority number is loaded. This list is iterated until a successful version is found. The VPL also supports manual rollback to a previous version (higher priority number).

The basic sequence for the dynamic software upgrade process is as follows:

- Downloading the Patch Kit
- Unpacking the Patch Kit
- Configuring the Plugin
- Loading the Plugin
- Rolling Back to a Previous Plugin Version

For the detailed procedure on performing dynamic software upgrade, refer to the *Configuring Dynamic Software Upgrade* section of the *Application Detection and Control Configuration* chapter.

License Requirements

From Release 21.6 onwards, DSU is a licensed-controlled feature. A separate feature license may be required. Contact your Cisco account representative for detailed information on specific licensing requirements. For information on installing and verifying licenses, refer to the *Managing License Keys* section of the *Software Management Operations* chapter in the *System Administration Guide*.

Limitations for DSU

This section lists the limitations of Dynamic Software Upgrade.

- Support for session recovery is limited and there is no support for ICSR in this release.
- The system will allow loading two plugins at the most at any point of time. If there is a need to upgrade the system again, the oldest plugin will be unloaded.
- Detection state for a few subscribers may be lost if a plugin is unloaded from the memory.
- The newly upgraded plugin will be used for all new calls. The existing calls will continue to use the previous plugin.

ADC Protocol Group Detection

Application Detection and Control (ADC) performs traffic analysis and classifies flows into applications and its traffic type. To provide a high-level classification, the protocol grouping feature is implemented to support

various application/protocol groups like gaming, file-sharing, e-mail, communicator, etc. Protocol Grouping is done based on the functionality provided by the application. For example, applications like Skype and Yahoo are used for VoIP, so these applications are grouped as Communicator group. The feature is implemented based on the Dynamic Software Upgrade plugin philosophy.

For configuration-related information, refer to the *Configuring P2P Protocol Groups* section of the *Application Detection and Control Configuration* chapter.

Behavioral Traffic

Behavioral Traffic Analysis is a method to analyze network traffic such that all the traffic is analyzed by the generic behavior of each flow. ADC supports behavioral traffic analysis for P2P (Peer-to-Peer), Video, VoIP (Voice over IP), Upload and Download. If the generic behavior of protocols is detected and traffic classified correctly using behavioral analysis, lesser amount of unknown traffic flows can be seen. These behavioral detections must not be used for charging purposes. This feature is based on the Dynamic Software Upgrade plugin philosophy.

Behavioral P2P and behavioral VoIP are meant for zero day detection of P2P/file sharing protocols and VoIP traffic respectively. Behavioral Video is meant for support of video detection. Behavioral Upload/Download must detect flows of non-standard ports that cannot be detected by ECS. This is similar to client-server upload/download using HTTP/FTP/SFTP encrypted download.



Important

This feature is disabled by default and meant only for statistical purposes (not for charging purposes).

For configuration-related information, refer to the *Configuring Behavioral P2P and VoIP* section of the *Application Detection and Control Configuration* chapter.

SNI Detection

Server Name Indication (SNI) is an extension of the Transport Layer Security (TLS) protocol that provides a mechanism for the client to tell the server which hostname it is trying to connect to.

ADC detects encrypted traffic using the SNI field (signatures) of TLS/SSL (Secure Sockets Layer) traffic. Due to increased number of applications moving towards TLS/SSL, an option is provided to configure the SNI in ruledef and classify traffic based on the configured SNI with this release.

For detailed overview and configuration information, see the *Support for SNI Detection* chapter in this guide.

SSL Renegotiation Tracking

SSL Renegotiation flows can be detected by tracking the SSL Session ID and its associated protocol. This feature is disabled by default. CLI support is added to enable or disable this feature. The maximum entries of SSL Session ID tracked per Session Manager and the reduce factor can be configured.

Certain applications like Facebook, Gmail, Yahoo, Skype, Twitter, iCloud, etc. widely use the SSL Session Renegotiation feature in their mobile applications to reduce the computational intensive operations involved in a complete SSL negotiation.

Limitations: In certain cases, the SSL Renegotiation detection logic does not work if the SSL sessions involved in the negotiation is spread across more than one subscriber session.

For configuration-related information, refer to the *Configuring SSL Renegotiation* section of the *Application Detection and Control Configuration* chapter.

Analyzer Interworking

Analyzer interworking feature is implemented to analyze the various analyzers simultaneously if the flow is detected as P2P and based on ruledef priority, appropriate charging action will be taken. Currently supported analyzers are FTP, HTTP, RTSP and SIP. CLI support is added to enable or disable this feature. This feature is enabled by default if P2P detection/protocol is enabled.

For configuration-related information, refer to the *Configuring Analyzers* section of the *Application Detection and Control Configuration* chapter.

Traffic Sub-classification

ADC has the capability to detect network traffic for sub-classification of audio, file transfer, instant messaging, video, voipout or unclassified traffic. The duration of the call is a direct indication to the revenue impact of the network operator. The ADC in-line service is well poised to process the network traffic online to detect and control the presence of different network traffic, and generate records that can be used to calculate the traffic call duration.

ADC Support for TRM/FP

P2P flows now support the Transactional Rule Matching (TRM) feature. The TRM/FP feature enables the Enhanced Charging Service (ECS) to bypass per-packet rule matching on a transaction once the transaction is fully classified. This enables ECS to better utilize CPU resources and accommodate additional throughput for the system, thus improving the overall performance.

A transaction for TRM can be defined as the entire UDP flow, the ACK of the 3-way handshake to the FIN/RST of a TCP flow, or the HTTP request to the next HTTP request, or HTTP request to the FIN/RST for the final request of the flow. The TRM feature can also perform rule matching on IP L4 rules (UDP, TCP), HTTP, and HTTPS.

For more information on the TRM/FP feature, refer to the *ECS Administration Guide*.

ADC Support for FAPA

The Flow Aware Packet Acceleration (FAPA) feature improves the throughput in terms of PPS, by caching rule matching results of a flow for selected flows so as not to incur the lookup penalty for a large number of packets in that flow. This new accelerated path is capable of performing a full range of basic functions including handling charging, modification of packet headers, and incrementing various counters. The accelerated path dynamically evaluates the current flow state and reverts back to the slow path when the flow cannot be handled on the fast path.

TRM/FP support has been extended beyond rule-matching. The FAPA function identifies packets that need only a small amount of processing, and performs necessary tasks on these packets. Only those packets that do not require DPI are allowed to enter the Accelerated path. VoLTE, encrypted, HTTP, HTTPS, RTP and plain TCP/UDP traffic where L7 analysis is not enabled, and so on are all the flows that will get accelerated.



Important

A Flow Aware Packet Acceleration license is required on ASR5500 and VPC platforms.

P2P flows will be optimized and accelerated using FAPA. ADC when enabled with FAPA improves P2P performance considerably.

**Important**

FAPA accelerates P2P flows for most protocols except for some protocols/applications explicitly listed below.

FAPA accelerates some P2P flows for the following protocols and not all:

- Ares
- Bittorrent
- Didi
- DirectConnect
- Edonkey
- Iskoot
- PPlive
- Scydo
- Soulseek
- Thunder
- ThunderHS
- Tunnelvoice
- Viber
- Whatsapp
- Winny
- Zattoo

The following protocols do not support FAPA:

- ActionVoip
- BBM
- Blackdialer
- Facetime
- Gtalk
- Jabber
- Jumblo
- Kakaotalk
- Magicjack
- MyPeople
- Nateontalk
- Oscar
- Paltalk
- Plingm
- Skype
- Smartvoip
- Tango
- Voipdiscount
- Vopium
- Vtok

For more information on the FAPA feature, refer to the *ECS Administration Guide*.

ADC Support over Gx

The ADC Rule feature will support detection of application level flows as described in Release-11 of 3GPP standard. ADC Rules are certain extensions to dynamic and predefined PCC Rules in order to support specification, detection and reporting of an application flow. These rules are installed (modified/removed) by PCRF via CCA-I/CCA-U/RAR events. ADC rules can be either dynamic PCC or predefined PCC rules, and the existing attributes of dynamic and predefined rules will be applicable.



Important

ADC Rule support is a licensed-controlled feature. Contact your Cisco account representative for detailed information on specific licensing requirements.

When the license is not enabled, P2P continues to function as per its original behavior, that is, it monitors the traffic at the entire rulebase level. When the license is enabled, the P2P behavior changes such as to monitor traffic at per subscriber level.

In 19.3 and later releases, this feature is extended to support non-ADC based rules (ECS protocols) in addition to existing P2P protocols, and also detection of application flows for Group of Ruledefs. The following enhancements are supported:

- ADC rules support combination of P2P and non-P2P rule lines in the same ruledef.
- Detection of application flows based on group of ruledefs.
- Application START/STOP event reporting at instance level, that is, per flow basis. This was supported per Application ID basis in previous releases.
- Support of dynamic routes to analyzers for installed ADC rules. Dynamic routes will be supported only for these protocols - HTTP, HTTPS, FTP, RTP, RTCP and SIP.
- Support multi-line AND logic for rulelines when configuring ADC ruledefs.
- Removal of all PCC rules will result in termination of Application Detection for that application. In previous releases, if more than one PCC rule with same Application ID is installed, then removal of any of the PCC rules will terminate Application Detection for that application.

Dynamic PCC rule contains either traffic flow filters or Application ID. When Application ID is present, the rule is treated as ADC Rule. Application ID is the name of the ruledef which is pre-defined in the ASR 5500. This ruledef contains application filters that define the application supported by P2P protocols and non-P2P protocols.

In releases prior to release 19.3: PCEF will process and install ADC rules that are received from PCRF interface, and will detect the specified application(s) and report detection of application traffic to the PCRF. Reporting of application traffic are controlled by PCRF and generates Application Start/Stop events along with the Application ID. Application mute status can be enabled or disabled on both dynamic and predefined ADC rules. When mute is disabled, Application Start/Stop event trigger will be generated by PCEF for that specific Application ID. Mute status can be enabled or disabled by PCRF for dynamic rules, and configured on ASR 5500 for pre-defined rules.

In 19.3 and later releases: When a subscriber attaches to the network, PCRF will install ADC rule/Group of Ruledefs towards PCEF to detect Application flow. The Install ADC rules will additionally enable default routes to HTTP, HTTPS, FTP, RTSP, RTCP or SIP analyzer based on the rule-definition. The default routes use the standard ports associated with the respective protocol. When a new flow comes, the route matching happens for dynamic routes first, then static routes and finally default routes. When a flow matches that ADC

rule, an APP-START notification is sent to PCRF with Application ID, Instance ID and flow information. Instance ID is a unique identifier for a particular ADC flow. PCRF then takes necessary action for the detected application. When ADC flow terminates, an APP-STOP notification is sent to PCRF with Application ID and Instance ID.

The following types of ADC ruledefs can be configured.

- **ruledef adc_rule**

```

p2p protocol = <name>
p2p protocol-group = <name>
p2p behavioral = <name>
multiline-or all-lines
end

```

multiline-or all-lines is optional if rule contains only one line.
- **ruledef adc_rule_type2**

```

p2p protocol = <name>
p2p traffic-type = <sub_type_name>
end

```
- **ruledef adc_rule_type3**

```

p2p anymatch = TRUE
end

```

When **p2p any-match = TRUE** is configured, only one rule containing this rule line can be installed. This rule line must not be used with any other P2P rule line.

ADC Mute Customization

Earlier, 3GPP ADC over Gx did not support application MUTE status change. Once the application was muted, it was not possible to unmute it. From release 21.1, this feature introduces custom MUTE/UNMUTE functionality. ASR 5500 PCEF now supports customization to control reporting of the Application Detection Information CCRUs. For this, an AVP has been introduced with two possible values - custom MUTE and custom UNMUTE.

- A Gx message might contain both Standards based MUTE and the custom MUTE.
- Standards based MUTE is given preference over the custom MUTE/UNMUTE.
- A dynamic ADC rule can be installed and modified with a custom MUTE.
- Custom-Mute-Notification AVP can be sent by the PCRF in CCA-I and RAR.
- A dynamic ADC rule can be modified with a custom UNMUTE.
- On a custom MUTE for a given dynamic ADC rule, PCEF sends a single APPLICATION_START/ APPLICATION_STOP response for the entire application traffic rather the per flow APPLICATION_START /APPLICATION_STOP response.
- On a custom MUTE for a given dynamic ADC rule, if no APPLICATION_START has been sent prior to the custom MUTE then a single APPLICATION_START is sent on the next flow packet that hits the dynamic rule.
- On a custom MUTE for a given dynamic rule, the APPLICATION_START response is sent with the flow's 5-tuple information.
- On a custom MUTE for a given dynamic rule, the APPLICATION_START response is sent with TDF-Application-Instance-Identifier = 0.

- On a custom MUTE for a given dynamic rule, a single APPLICATION_STOP is sent when the last flow associated with the given dynamic rule is terminated. Such an APPLICATION_STOP will not contain 5-tuple information of the last flow and is sent with TDF-Application-Instance-Identifier = 0.
- On a custom UNMUTE for a given dynamic rule, APPLICATION_STARTs response is matched with the given dynamic rule and then sent to all the forthcoming flows.
- There is no change in behavior for a custom UNMUTE, which has not been custom MUTED or standard MUTED before UNMUTING. APPLICATION_STARTs and APPLICATION_STOPs is continued to be sent per flow as before.
- On a custom UNMUTE, PCEF sends an APPLICATION_STOP each for all flows that terminate then onwards.
- A given dynamic rule is recovered in both SR and ICSR including the Custom MUTE/UNMUTE status. The APPLICATION_START status for a given dynamic rule is check-pointed and recovered. This ensures that an extra APPLICATION_START is not sent to the PCRF post recoveries.

TOS/DSCP Support

In 19.3 and later releases, the ADC functionality is extended to identify applications and distinguish bearer traffic based on TOS/DSCP. DSCP/TOS based ADC dynamic rules over Gx will be supported for default and dedicated bearers. Bearer mapping and rule matching will be done based on DSCP/TOS value. Filters can be created for PCC rules based on TOS-Traffic-Class AVP under flow information.

When a subscriber attaches to the network, PCRF will install PCC rule with TOS/DSCP filter towards PCEF. PCEF will create a dedicated bearer and send the packet filters to UE as well. When a new flow comes with first packet as Uplink, UE does bearer matching based on the TOS/DSCP value, and sends flow on the correct dedicated bearer. For downlink packet, ECS does bearer lookup and assigns correct bearer to the flow based on the TOS/DSCP value.

ADC Event reporting will contain flow template with outer IP 3 tuples (Source IP, Destination IP, Port). L4-L7 rule match will also work for PMIP service.

Limitations

The limitations for the ADC over Gx feature are:

- Registration of the duplicate application IDs are not supported.
- Readdress/Redirection for P2P flows will not be supported.
- Redirection happens only on transactions of GET/Response.
- Port based, IP Protocol based, and URL based applications are not supported.
- Pre-configured options (precedence, redirect-server-ip) for dynamic ADC Rules are not supported.
- Simultaneous instances of an application for the same subscriber are not distinguished.
- Flow recovery is not supported for application flows.

Dynamic Advertisement Server Correlation

ADC supports many streaming applications that are ad-supported and the flows corresponding to these third-party advertisements are generic. These advertisement flows could not be differentiated from specific application flows based on the deterministic pattern. As part of this feature, a configurable option is provided to dynamically correlate advertisement flows and associate the respective applications.

Any advertisement service is associated with the corresponding application protocol. The type of ad-flow will be configured per application. Refer to the *Configuring P2P Advertisement server* section in the *Application*

Detection and Control Configuration chapter for more information on configuring the P2P Advertisement Server correlation group.

Limitations

Some limitations of this feature are listed below:

- Maximum number of ads groups that can be configured is 100.
- Maximum number of ad-source lines per ads-group that can be configured is 32.
- Configuration will take effect only for new flows.
- Applications added using TLS/SNI ruledefs (custom defined protocols) will not be supported.

Bulk Statistics Support

The system can be configured to collect bulk statistics (performance data) and send them to a collection server (called a receiver). Bulk statistics are statistics that are collected in a group. The individual statistics are grouped by schema. ADC uses P2P schema for bulk statistics support.



Important

The bulk statistics format previously supported by the older implementation for individual ADC protocols in ECS schema is deprecated, and the new bulk statistics format is supported in 14.0 and later releases in the new P2P schema.

The P2P schema is designed in such a way that all variables that end with numeral value "name" are used to extract all data with numeral values "value" for all the protocols supported by the currently loaded patch. With the Dynamic Software Upgrade, the operator need not change the P2P schema by adding or removing variables related to a particular protocol manually for each new patch.

The following is a sample configuration of bulk statistics in the P2P schema:

p2p schema p2p format

```
"%p2p-protocol%\n%p2p-protocol-group%\n%p2p-uplnk-bytes-name%:%p2puplnk-bytes-value
%\n%p2p-dwlnk-bytes-name%:%p2p-dwlnk-bytes-value%\n%p2p-uplnk-pktsname%:%p2p-uplnk-pkts-value%
p2p-uplnk-pkts-value%\n%p2p-dwlnk-pkts-name%:%p2p-dwlnk-pkts-value%\n%p2pduration-name%:
%p2p-duration-value%\n-----\n"
```



Important

If detection of a specific P2P protocol is enabled, bulk statistics for that protocol will be automatically generated based on the plugin installed on the chassis. In the case of protocols that support sub-classification (audio/file transfer/instant messaging/video/voipout/unclassified), the bulk statistics will be dynamically generated for each of the supported sub-classifications per protocol and also the corresponding total count which is the sum of values of the sub-classified data.

For more information, see the *P2P Schema* chapter of the *Statistics and Counters Reference*.

How ADC Works

As part of traffic analysis, packets will be first passed through the ADC analyzers when "p2p dynamic-flow-detection" is enabled. If it is not detected as P2P by any of the ADC analyzers, then it will follow the rule matching to find an application analyzer.

ADC analyzers examine uplink and downlink traffic and use rules that define what packet content to take action on and what action to take when the rule is true. The analyzers also generate usage records for the billing system. The rules are configured/defined in the same way as ECS in-line service ruledefs and rulebases.

For a few specific protocols, packets will be sent to non-ADC analyzers even after marking the flow as P2P. If the flow is marked as P2P and also analyzed by other analyzers, the statistics for display and debug purposes reflect in both analyzers. The EDR also displays the ADC application/protocol names if configured.

ADC also interfaces to a PCRF Diameter Gx interface to accept policy ACLs and rulebases from a PDF. ADC supports real-time dynamic policy updates during a subscriber session. This includes modifying the subscriber's policy rules during an active session by means of ACL name and Rulebase name.

In Gx interface, a Charging Rulebase will be treated as a group of ruledefs. A group of ruledefs enables grouping rules into categories, so that charging systems can base the charging policy on the category. When a request contains names of several Charging Rulebases, groups of ruledefs of the corresponding names are activated. For ADC rules to work in the group of ruledefs, P2P detection has to be enabled in the rulebase statically.

Static policy is supported initially. A default subscriber profile is assumed and can be overwritten on the gateway. Per-subscriber static policy is pulled by the gateway from the AAA service at subscriber authentication.

The following figure illustrates how packets travel through the system using ADC. The packets are investigated and then handled appropriately using ruledefs for charging.

Figure 1: Overview of Packet Processing in ECSv2

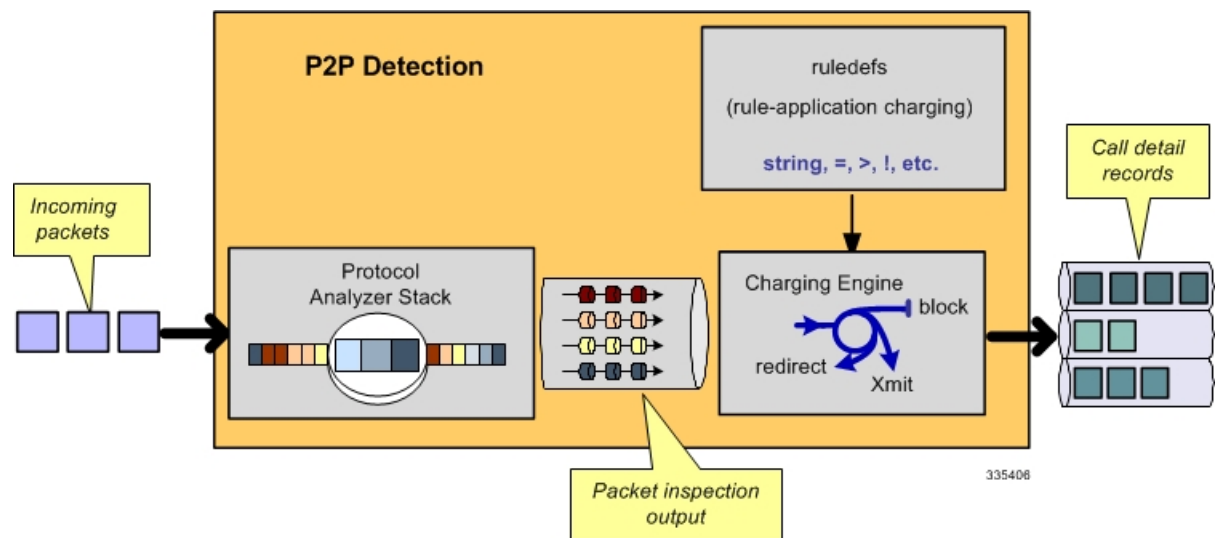

Limitations

This section lists the limitations for the ADC protocols that support audio and video sub-classification.

If Audio and Video contents are in the same flow (TCP/UDP), video is considered as the predominant component and the flow is marked as "video". In this scenario, throttling video will block both audio and video. Throttling only audio or video is not possible.



CHAPTER 2

Application Detection and Control Configuration

This chapter describes how to configure the Application Detection and Control (ADC) feature.

This chapter covers the following topics:

- [Configuring Dynamic Software Upgrade, on page 13](#)
- [Configuring System for ADC, on page 15](#)
- [Gathering ADC Statistics, on page 26](#)
- [P2P Reports, on page 27](#)

Configuring Dynamic Software Upgrade

This section describes how to install and configure the dynamic software upgrade plugin in the ASR 5500.

How to perform Dynamic Software Upgrade

The procedure for the dynamic software upgrade is as follows:

Step 1 Obtain the patch TAR file from your designated Cisco representative.

Step 2 Copy the patch file into the */flash* directory of the ASR 5500 chassis by the TFTP or FTP method.

```
patch plugin plugin_name filepath
```

For example:

```
patch plugin p2p /flash/libp2p-1.97.354.so.tgz
```

Step 3 After the file has been copied, install the plugin using the following **install plugin** command from the Exec mode.

```
install plugin plugin_name patch_file_name
```

For example:

```
install plugin p2p patch_libp2p-1.97.354.so.tgz  
patch file patch_libp2p-1.97.354.so.tgz installed successfully
```

Important The plugin will be unpacked into */flash/patch/p2p* directory. Ensure that there is enough space in the */flash* directory before installing a given patch. Verify if the file is installed correctly using the **dir** */flash/patch/p2p/[patch_version_number.so]* command. For example: `dir /flash/patch/p2p/libp2p-1.97.354.so`

Step 4 After the patch has been successfully installed, the patch version must be configured before it can be loaded into the system. To configure the patch before any other version of patch, first check the existing plugin configuration using the following command. This command entered in the Exec mode is used to list the priorities on the configured patches.

```
show plugin plugin_name
```

For example:

```
show plugin p2p
```

Important The data is read from */flash/module.sys* and if it is not available, reads the default priorities from */etc/plugin.conf* (read only) and lists the priorities.

Step 5 Configure the plugin using the **plugin** command from the Global Configuration mode, and enters the Plugin Configuration mode.

```
plugin <plugin_name>
```

```
module priority <number> version <module_version>
```

For example:

```
configure
  plugin p2p
  module priority 1 version 1.97.354
```

The plugin name must match the name of the plugin which has been copied to and unpacked on the system or an error message is displayed.

Important The above configuration will be internally stored in */flash/module.sys* so that the current configuration survives an ASR 5500 reload. Ensure that the file is not deleted by mistake.

Step 6 Enter the following command to update the specified module running in the system. Wait 5-10 seconds for the update to occur on all the PSC cards.

```
update module <plugin_name>
```

For example:

```
update module p2p
Update to module p2p version 1.97.354 successful
```

When the above command is issued, the priorities configured using **module priority** command is converted into a Module priority List and then the module with least priority is loaded. If it fails to load, the module with next higher priority is attempted and so on till a successful load occurs.

Important If none of the configured modules load properly, then the system automatically tries to load the default patch that comes along with the currently loaded build.

Step 7 Enter the following command to rollback a running patch version in the system:

```
rollback module <plugin_name>
```

For example:

```
rollback module p2p
rollback plugin p2p module priority 10 library /var/opt/lib/libp2p-1.97.357.so load successful
```

When the above command is issued, the system automatically tries to load the patch with next highest priority in the VPL and if that fails, it tries to load the next one and so on.

Step 8 Enter the following command in Exec mode to view the status of the currently running VPL. Ensure that the patch with least priority is loaded. Others will have the "loaded" column displayed as "no".

```
show module <plugin_name> [ verbose ]
```

For example:

```
show module p2p
Module p2p
Priority  version  loaded  location  update/rollback time  status
1      1.97.354    no    /var/opt/lib  FRI Feb 28 07:15:42 2014  success
2      1.97.357    yes   /var/opt/lib  FRI Feb 28 07:15:42 2014  success
X      1.82.118    no    /lib          (never)                N/A
```

Step 9 Delete older patch files. Unconfigure plugin from configuration and manually delete the older patch files from `/flash/patch/<plugin_name>` directory to save disk space if necessary.

```
plugin <plugin_name>
no module priority <plugin_number>
```

For example:

```
configure
 plugin p2p
  no module priority 1
 end
del /flash/patch/p2p/libp2p-1.97.354.so
del /flash/patch/p2p/patch_libp2p-1.97.354.so.tgz
```

Step 10 For an ICSR setup:

If the ASR 5500 system is in ICSR mode (geographical redundancy) then the operator has to repeat the above steps for update/rollback in both the systems individually. If it is not done, then after an SRP switchover the new active ASR 5500 comes up with an outdated plugin priority which can lead to loading an older version of patch for a particular plugin. Using the **srp validate-configuration** command, check for the same plugin module priority and raise error if it is different across the active-standby pair.

Configuring System for ADC

This section lists the high-level steps to configuring the system with enhanced charging services for ADC in conjunction with ECS services.

To configure the system for ADC support with ECS:

- Step 1** Set initial configuration parameters such as modifying the local context as described in the [Initial Configuration](#) section.
- Step 2** Enable the Enhanced Charging service with ADC and set basic ECS parameters such as service configuration, Ruledefs, charging actions, and EDRs as described in the [ADC Configuration](#) section.
- Step 3** Save your configuration to flash memory, an external memory device, and/or a network location using the Exec mode command `save configuration`. For additional information on how to verify and save configuration files, refer to the *System Administration Guide* and the *Command Line Interface Reference*.

Important Commands used in the configuration examples in this section provide base functionality to the extent that the most common or likely commands and/or keyword options are presented. In many cases, other optional commands and/or keyword options are available. Refer to the *Command Line Interface Reference* for complete information regarding all commands.

Initial Configuration

To perform initial system configuration for ADC support with ECS:

- Step 1** Enable ACS as described in the [Enabling Enhanced Charging, on page 16](#) section.
- Step 2** Set local system management parameters as described in the [Modifying the Local Context, on page 16](#) section.

Enabling Enhanced Charging

Use the following configuration example to enable enhanced charging on the system:

```
configure
  require active-charging
end
```



Important After you configure the **require active-charging** command, you must save the configuration and then reload the chassis for the command to take effect. For information on saving the configuration file and reloading the chassis, refer to the *System Administration Guide* for your deployment.

Modifying the Local Context

Use the following configuration example to set the default subscriber and AAA group in the local context:

```
configure
  context local
    interface <interface>
      ip address <ipv4/ipv6_address/mask>
      ip arp timeout <timeout>
    exit
  server ftpd
  exit
  server sshd
    subsystem sftp
  exit
  server telnetd
  exit
  subscriber default
  exit
  administrator <security_admin> encrypted password <password> ftp
  aaa group default
```

```

    exit
  gtppt group default
  exit
  ip route <route> SPIO1
  exit
  port ethernet <slot/port>
    no shutdown
    bind interface <interface> local
  exit
  snmp engine-id local <id_number>
end

```

ADC Configuration

To configure ADC with ACS:

-
- Step 1** Create the ACS service as described in the [Creating the Active Charging Service, on page 17](#) section.
 - Step 2** Configure ADC rules as described in the [Configuring ADC Rules](#) section.
 - Step 3** Configure P2P protocol groups as described in the [Configuring P2P Protocol Groups, on page 19](#) section.
 - Step 4** Configure behavioral traffic as described in the [Configuring Behavioral Detection, on page 20](#) section.
 - Step 5** Configure the P2P Advertisement server correlation group as described in the [Configuring P2P Advertisement server, on page 21](#) section.
 - Step 6** Configure SSL renegotiation as described in the [Configuring SSL Renegotiation](#) section.
 - Step 7** Configure analyzers as described in the [Configuring Analyzers](#) section.
 - Step 8** Configure the charging action as described in the [Configuring the Charging Action, on page 22](#) section.
 - Step 9** Configure the rulebase as described in the [Configuring the Rulebase](#) section.
 - Step 10** *Optional:* Set EDR formats as described in the [Setting EDR Formats](#) section.
 - Step 11** Configure the IP protocol and server port mapping for EDRs as described in the [Configuring IP Protocol and Server port mapping, on page 24](#) section.
 - Step 12** Configure the P2P events for generation of EDRs as described in the [Configuring EDR for P2P Events, on page 25](#) section.

Important Commands used in the configuration examples in this section provide base functionality to the extent that the most common or likely commands and/or keyword options are presented. In many cases, other optional commands and/or keyword options are available. Refer to the *Command Line Interface Reference* for complete information regarding all commands.

Creating the Active Charging Service

Use the following configuration example to create the ACS service:

```

configure
  active-charging service <acs_service_name> [ -noconfirm ]
end

```



Important The **p2p-dynamic-rules protocol all** CLI command under Active Charging service is deprecated, and not supported in 12.0 and later releases.

Configuring ADC Rules

Use the following configuration example to set the P2P detection protocols in the ACS and the rule definitions for each P2P protocol.



Important The list of P2P protocols will be populated based on the currently installed plugin.

```

configure
  active-charging service <acs_service_name>
  p2p-detection protocol all
  ruledef <charging_ruledef_actionvoip>
  p2p protocol = actionvoip
  exit
  ruledef <charging_ruledef_facebook>
  p2p protocol = facebook
  exit
  ruledef <charging_ruledef_jabber>
  p2p protocol = jabber
  exit
  ruledef <charging_ruledef_skype>
  p2p protocol = skype
  exit
# Configuration example to report audio, file transfer, instant messaging, video, voipout
and unclassified components:
  ruledef <charging_ruledef_<protocol>_audio>
  p2p protocol = <protocol>
  p2p traffic-type = audio
  exit
  ruledef <charging_ruledef_<protocol>_ft>
  p2p protocol = <protocol>
  p2p traffic-type = file-transfer
  exit
  ruledef <charging_ruledef_<protocol>_im>
  p2p protocol = <protocol>
  p2p traffic-type = im
  exit
  ruledef <charging_ruledef_<protocol>_video>
  p2p protocol = <protocol>
  p2p traffic-type = video
  exit
  ruledef <charging_ruledef_<protocol>_voipout>
  p2p protocol = <protocol>
  p2p traffic-type = voipout
  exit

```

```

ruledef <charging_ruledef_<protocol>_unclassified>
p2p protocol = <protocol>
p2p traffic-type = unclassified
exit
end

```

Configuring ADC Ruledef Types

Use the following configuration to configure ADC ruledefs in support of the ADC over Gx feature:

```

configure
  active-charging service service_name
    ruledef adc_rule_type1
      p2p protocol = protocol_name
      p2p protocol-group = protocol_group
      p2p behavioral = behavioral_list
      multi-line-or all-lines
      exit
    ruledef adc_rule_type2
      p2p protocol = protocol_name
      p2p traffic-type = traffic-type
      exit
    ruledef adc_rule_type2
      p2p any-match = TRUE
      exit

```

Sample Ruledef Configuration for Windows Updates

Use the following ruledef CDP configuration for detecting Windows Updates:

```

Ruledef Name: windowsupdate
tls sni ends-with windowsupdate.com
tls sni ends-with update.microsoft.com
http host ends-with windowsupdate.com
http host ends-with update.microsoft.com
tls set-app-proto windowsupdate
Rule Application Type: Charging
Copy Packet to Log: Disabled
Tethered Flow Check: Disabled
Multi-line OR: All Lines

```

Configuring P2P Protocol Groups

Use the following configuration example to configure P2P protocol groups:

```

configure
  active-charging service <acs_service_name>
    ruledef <ruledef_name>
      [ no ] p2p protocol-group <operator> <group_list>
    end

```

Notes:

<group_list> must be one of the following:

- **anonymous-access**
- **business**
- **communicator**
- **cloud**
- **e-mail**
- **e-news**
- **e-store**
- **internet-privacy**
- **filesharing**
- **gaming**
- **p2p-anon-filesharing**
- **p2p-filesharing**
- **remote-control**
- **social-nw-gaming**
- **social-nw-generic**
- **social-nw-videoconf**
- **standard**
- **streaming**
- **untagged**

For more information, refer to the *ACS Ruledef Configuration Mode Commands* chapter of the *Command Line Interface Reference*.

Configuring Behavioral Detection

Use the following configuration example to configure behavioral detection of unidentified traffic:

```
configure
  active-charging service <acs_service_name>
    [ no ] p2p-detection behavioral <behavioral_list>
  end
```

Use the following to define rule expressions to match behavioral detection type — P2P, Video, VoIP, Behavioral Upload or Behavioral Download.

```
configure
  active-charging service <acs_service_name>
    ruledef <ruledef_name>
      [ no ] p2p behavioral <operator> <behavioral_list>
    end
```

Notes:

- Here the *<behavioral_list>* is the list of supported behavioral detection logic populated from the currently loaded P2P plugin. The supported behavioral list is:
 - **download**: Detects unknown flows which are data download using behavioral analysis
 - **p2p**: Detects P2P and file sharing protocols using behavioral analysis
 - **upload**: Detects unknown flows which are data upload using behavioral analysis
 - **video**: Detects video flows using behavioral analysis

- **voip**: Detects VoIP (voice and video) protocols using behavioral analysis

Behavioral P2P, behavioral video and behavioral VoIP are meant for zero day detection of P2P/file sharing protocols, video traffic and VoIP traffic respectively. Behavioral Upload/Download must detect flows of non-standard ports that cannot be detected by ECS. This feature is meant only for statistical purposes (not for charging purposes). For more information, refer to the *ACS Configuration Mode Commands* and *ACS Ruledef Configuration Mode Commands* chapters of the *Command Line Interface Reference*.

Configuring P2P Advertisement server

Use the following configuration to configure the P2P Advertisement server correlation group:

configure

```

active-charging service acs_service_name
  [ no ] p2p ads-group ads_group_name
    [ no ] ad-source operator http_host_name/ssl_server_name
    [ no ] map-to-application { p2p_list } +
  end

```

Notes:

- On entering this command, the CLI prompt changes to the P2P Advertisement Server Group Configuration Mode:

```
[context_name]hostname(config-acs-p2p-ads)#
```

- *ads_group_name* must be an alphanumeric string of 1 through 63 characters.
- The following two commands are supported in the new P2P Advertisement Server Group Configuration Mode.

- **ad-source** *operator http_host_name/ssl_server_name*: Configures the P2P Advertisement source that can be a HTTP host or SSL server. SSL supports the Server Name indication (SNI) field.

operator can be "=", "contains", "ends-with" or "starts-with".

http_host_name/ssl_server_name must be an alphanumeric string of 1 through 127 characters.

- **map-to-application** *p2p_list*: Configures the P2P advertisement application that will map the advertisement group to the corresponding application/protocol. *p2p_list* is the list of protocols/applications supported in the P2P plugin. The maximum number of map-to-application rule lines that can be configured is equal to the number of the applications present in *p2p_list*.
- The existing analyzer statistics and EDR will accumulate P2P related statistics based on the ads-group configuration. Bulk statistics will accumulate "ads" subtype statistics for the configured protocol in p2p-ads-group.
- The existing ruledef configuration will be used to configure any charging action.

For more information, refer to the *ACS Configuration Mode Commands* and *P2P Advertisement Server Group Configuration Mode Commands* chapters of the *Command Line Interface Reference*.

Configuring SSL Renegotiation

Use the following configuration example to configure SSL renegotiation:

```

configure
  active-charging service <acs_service_name>
    [ no ] p2p-detection attribute { <attribute_list> [
<sub_attribute_name> <sub_attribute_value> ] }
  end

```

Notes:

- Here the `<attribute_list>` is the list of configurable P2P detection attributes populated from the currently loaded P2P plugin.

Supported attribute: **ssl-renegotiation**

- `<sub_attribute_name>` is the list of configurable P2P detection sub-attributes related to the attribute selected from the attribute list. This list is populated from the currently loaded P2P plugin.

Supported sub-attributes if selected attribute is **ssl-renegotiation**:

- **max-entry-per-sessmgr**
- **id-reduce-factor**

- `<sub_attribute_value>` is the value of the selected sub-attribute. If sub-attribute is not specified, the default value set in the P2P plugin will be used.

For more information, refer to the *ACS Configuration Mode Commands* chapter of the *Command Line Interface Reference*.

Configuring Analyzers

Use the following configuration example to configure analyzers for ECS analysis:

```

configure
  require active-charging
  active-charging service <acs_service_name>
    [ no ] p2p-detection ecs-analysis { all | ftp | http | rtsp
| sip }
  end

```



Important

After you configure **require active-charging** and **active-charging service**`<acs_service_name>` commands, you must save the configuration and then reload the chassis for the command to take effect. For information on saving the configuration file and reloading the chassis, refer to the *System Administration Guide* for your deployment.

For more information, refer to the *ACS Configuration Mode Commands* chapter of the *Command Line Interface Reference*.

Configuring the Charging Action

Use the following configuration example to configure the charging actions:

```

configure
  active-charging service <acs_service_name>
    charging-action <charging_action_name1>

```



```

    flow limit-for-bandwidth direction downlink peak-data-rate 4000
    peak-burst-size 1024 violate-action discard committed-data-rate 3200
    committed-burst-size 512 exceed-action discard
    exit
    charging-action <charging_action_name2>
    content-id 1
    exit
    charging-action <charging_action_name3>
    flow action terminate-flow
    end

```

Configuring the Rulebase

Use the following configuration example to configure the rulebases for P2P.

```

configure
active-charging service <acs_service_name>
rulebase <rulebase_name>
action priority <action_priority> { [ dynamic-only { adc [ mute ] } |
static-and-dynamic | timedef <timedef_name> ] { group-of-ruledefs
<ruledefs_group_name> | ruledef <ruledef_name> } charging-action <charging_action_name> [
monitoring-key <monitoring_key> ] [ description <description> ] }
# Configuration
example to detect P2P applications configured for the Active Charging
Service:
action priority <priority> ruledef <charging_ruledef_actionvoip> charging-action
<charging_action_name>
action priority <priority> ruledef <charging_ruledef_facebook> charging-action
<charging_action_name>
action priority <priority> ruledef <charging_ruledef_jabber> charging-action
<charging_action_name>
action priority <priority> ruledef <charging_ruledef_skype> charging-action
<charging_action_name>
# Configuration example to report audio, file transfer, instant messaging, video, voipout
and unclassified components:
action priority <priority> ruledef <charging_ruledef_protocol_audio>
charging-action <charging_action_name>
action priority <priority> ruledef <charging_ruledef_protocol_ft> charging-action
<charging_action_name>
action priority <priority> ruledef <charging_ruledef_protocol_im> charging-action
<charging_action_name>
action priority <priority> ruledef <charging_ruledef_protocol_video>
charging-action <charging_action_name>
action priority <priority> ruledef <charging_ruledef_protocol_voipout>
charging-action <charging_action_name>
action priority <priority> ruledef <charging_ruledef_protocol_unclassified>
charging-action <charging_action_name>
end
end

```

Notes:

- The **adc** keyword option specifies the ruledef to be given as ADC rule. This predefined rule can be activated from PCRF/Gx. This can be configured only with the **dynamic-only** keyword and optional along with ruledef. Group-of-ruledefs is not supported in this release.

- The **mute** keyword is optional and can be configured only with the **adc** keyword. This keyword option will disable ADC application reporting to PCRF, that is, will mute the Application Start and Application Stop notifications to PCRF/Gx. Detection of protocols in the rule will still happen. Whenever the application traffic matches the specified ruledef for the first time in that flow, it is considered as Application Start. At the end of flow, it is considered as Application Stop.

Setting EDR Formats

ECS generates postpaid charging data files which can be retrieved from the system periodically and used as input to a billing mediation system for post-processing. Event Detail Records (EDRs) are generated according to action statements in rule commands.

Up to 32 different EDR schema types may be specified, each composed of up to 32 fields or analyzer parameter names. The records are written at the time of each rule event in a comma-separated (CSV) format. This configuration aids in capturing the detected P2P protocol data in the EDR.

Use the following example to set the EDR configuration:

```
configure
  active-charging service <ecs_service>
    edr-format <edr_flow_format>
      rule-variable traffic-type priority <priority>

      rule-variable p2p duration priority <priority>
      attribute sn-start-time format seconds priority <priority>
      attribute sn-end-time format seconds priority <priority>
      attribute radius-calling-station-id priority <priority>
      rule-variable ip server-ip-address priority <priority>
      attribute sn-server-port priority <priority>
      attribute sn-port-service-name priority <priority>
      attribute sn-app-protocol priority <priority>
      attribute sn-parent-protocol priority <priority>
      rule-variable ip protocol priority <priority>
      attribute sn-ip-protocol-name priority <priority>
      rule-variable p2p protocol priority <priority>
      rule-variable p2p protocol-group priority <priority>
      attribute sn-volume-amt ip bytes uplink priority <priority>
      attribute sn-volume-amt ip bytes downlink priority <priority>
      attribute sn-volume-amt ip pkts uplink priority <priority>
      attribute sn-volume-amt ip pkts downlink priority <priority>
      rule-variable bearer 3gpp charging-id priority <priority>
      rule-variable bearer 3gpp imei priority <priority>
      rule-variable bearer 3gpp rat-type priority <priority>
      rule-variable bearer 3gpp user-location-information priority
<priority>
    end
```

For information on EDR format configuration and rule variables, refer to the *EDR Format Configuration Mode Commands* chapter of the *Command Line Interface Reference Guide*.

Configuring IP Protocol and Server port mapping

Use the following configuration to enable IP protocol and server port mapping for EDRs:

```

configure
  active-charging service <acs_service_name>
  [ default | no ] edr-ipproto-port-map
end

```

For information, refer to the *ACS Configuration Mode Commands* chapter of the *Command Line Interface Reference*.

Configuring EDR for P2P Events

ADC supports sub-protocol detection for certain applications like Skype, Yahoo, MSN, GTalk, etc. Along with sub-protocol tracking, the application detection logic can track start and end duration of audio/video flow. This audio-end/video-end tracking heavily depends on the audio/video patterns used by the application detection logic. For example, in the case of audio flow start for a sub-protocol tracking, application detection logic begins tracking the start time and if that flow toggles to another sub-protocol that is video or unclassified, the end time for that sub-protocol is set and the EDR for that flow is dumped. Since certain applications use simultaneous flows for audio/video, parallel flow is tracked for all such flows instead of tracking separated audio/video flows.

Use the following configuration to generate EDRs for P2P events. This command is associated with the Dynamic Software Upgrade process.

```

configure
  active-charging service <acs_service_name>
  rulebase <rulebase_name>
  edr p2p <p2p_event_list> [ charging-edr <charging_edr_format_name> |
edr-format <edr_format_name> | reporting-edr <reporting_edr_format_name> ] +
end

```



Important

When the 1.97.357 ADC Plugin is used, Voice Duration details in EDR logs are missing. This has been fixed in plugins later than 1.97.357.

Notes:

- The plugin supports only the "audio-end" and "video-end" events. The P2P event list can be any P2P event that is supported by the plugin.
- The EDR generated for audio-end/video-end must not be used for flow analysis, and must be used only for audio/video duration analysis.
- For audio/video duration analysis (for example, VCD reports), the "sn-closure-reason" field must be checked to identify the reason for closure and the appropriate EDR chosen to generate the reports. The "sn-closure-reason" field will be set to **14** for capturing audio-end and video-end generated EDRs. For example, in case of audio-end events, all VoIP call related statistics such as VoIP duration and bytes/packets are captured along with traffic-type field set as "audio" and sn-closure-reason set as "14".

For information, refer to the *ACS Rulebase Configuration Mode Commands* chapter of the *Command Line Interface Reference*.

Gathering ADC Statistics

In the following table, the first column lists what statistics to gather, the second column lists an action to perform, and the third column describes what information is displayed or what information to look for in the resulting output.

Table 1: Gathering Statistics

Statistics Wanted	Action to Perform	Information to Look For
Analyzer statistics	show active-charging analyzer statistics name p2p verbose	The output of this command displays the analyzer statistics if a P2P analyzer is used. Since the analyzer statistics are not bound to any service, the traffic information per gateway can be obtained.
Ruledef statistics	show active-charging ruledef statistics name <name>	The output of this command displays the Ruledef statistics including the packet count, byte count and hits.
P2P flow statistics	show active-charging flows type p2p traffic-type audio show active-charging flows type p2p traffic-type file-transfer show active-charging flows type p2p traffic-type im show active-charging flows type p2p traffic-type video show active-charging flows type p2p traffic-type voipout show active-charging flows type p2p traffic-type unclassified	The output of this command displays the number of P2P audio, file transfer, instant messaging, video, voipout and unclassified flows.
Charging Action information	show active-charging charging-action statistics	The output of this command displays the charging action information and corresponding statistics configured in the active charging service.
Transmit and Receive data	show active-charging sessions tx-data <operator> <bytes> show active-charging sessions rx-data <operator> <bytes>	The output of the command displays the information for sessions that have received or transmitted data which matches the criteria.

Statistics Wanted	Action to Perform	Information to Look For
Sessions using specific protocol	show active-charging sessions type p2p application <protocol> show active-charging sessions full all	The output of this command displays information for the sessions using the specified protocol.
Total and current P2P flows and P2P audio, file-transfer, im, video, voipout, or unclassified flows	show active-charging subsystem all	The output of this command displays total and current P2P flows and P2P audio/file-transfer/instant messaging/video/voipout/unclassified flow statistics, and total number of subscribers.
Voice Statistics	show active-charging analyzer statistics name p2p application [actionvoip facetime gtalk icall jumblo magicjack msn oscar plingm rynga skype smartvoip talkatone voipdiscount vopium yahoo] verbose	The output of this command displays the voice and non-voice analyzer statistics for voice supported protocols.
P2P Protocol Group Statistics	show active-charging analyzer statistics name p2p protocol-group wide all verbose	The output of this command displays the P2P protocol group statistics if a P2P analyzer is used.
Subscriber Readdress Statistics	show subscribers callid <callid> adc readdress statistics	In support of the ADC over Gx feature, the output of this command displays readdress statistics at subscriber level for a given call ID.

Supported Bulk Statistics

ADC bulk statistics are available as part of the P2P schema. If detection of a specific P2P protocol is enabled, bulk statistics for that protocol will be automatically generated using the Dynamic Software Upgrade plugin installed on the chassis. In the case of protocols that support sub-classification (audio/video/unclassified), the bulk statistics will be generated for each of the supported sub-classifications per protocol and also the corresponding cumulative count.

For information on ADC bulk statistics and bulk statistics configuration and collection, refer to the *Bulk Statistics Configuration Mode Commands* chapter of the *Command Line Interface Reference*, and the *Statistics and Counters Reference*.

P2P Reports

The P2P reports provide details of the bandwidth consumption of P2P traffic over time. These reports are used to analyze network performance, identify the customer trends, network usage patterns, and network categorization.

**Important**

In 9.0 and earlier releases, the P2P reporting functionality was available in the Web Element Manager software. For more information, refer to the *Web Element Manager Online Help* documentation.

**Important**

In 10.0 and later releases, the P2P reporting functionality is supported in Mobility Unified Reporting (MUR) / Mobility Unified Reporting and Analytics (MURAL) system. For more information on MUR, refer to the *Mobility Unified Reporting Online Help* documentation. For more information on MURAL support, refer to the *MURAL Installation and Administration Guide* and *MURAL User Guide*.

The following bandwidth usage reports are supported:

- Cumulative analyzer count - representing the total bandwidth consumed by the P2P traffic in bits/sec. Daily, monthly or yearly reports are supported.
- Total bandwidth consumed P2P traffic against other protocols like HTTP, RTSP, etc. Daily or monthly reports are supported.
- Per protocol type - total bandwidth consumed by the individual P2P protocol traffic in packets/sec or bytes/sec plotted against time range or date range. Daily reports are supported. The graph uses separate colors to differentiate among the multiple protocol types.
- The number of active users per application for specified date/time range. Daily reports are supported.
- Analysis of the percentage of total bandwidth consumed by P2P traffic from the total subscriber traffic. Weekly reports are supported.

**Important**

For additional information about viewing reports, refer to the *Web Element Manager Online Help* documentation.



CHAPTER 3

App-based Tethering Detection

- [Feature Information, on page 29](#)
- [Feature Description, on page 30](#)
- [How It Works, on page 30](#)
- [Configuring App-based Tethering Detection, on page 30](#)
- [Monitoring and Troubleshooting the App-based Tethering Detection, on page 32](#)

Feature Information

Summary Data

Status	New Feature
Introduced-In Release	21.2
Modified-In Release(s)	Not Applicable
Applicable Product(s)	P-GW
Applicable Platform(s)	ASR 5500
Default Setting	Disabled
Related CDETS ID(s)	CSCvd65410
Related Changes in This Release	Not Applicable
Related Documentation	ADC Administration Guide Command Line Interface Reference

Revision History



Important

Revision history details are not provided for features introduced before release 21.2.

Revision Details	Release	Release Date
New in this release.	21.2	April 27, 2017

Feature Description

The tethering of IPv4 and IPv6 traffic has increased, and the native device recognition techniques are less viable with the advent of proxy tethering Apps on smartphones.

A new App-based Tethering Detection is introduced with this release. This solution interwork with other existing Tethering Detection techniques.

How It Works

This solution is built around the existing ADC plugins for App identifications. Tethering specific patterns are added on top of recognized App plugins. These plugins successively return if the App flow is tethered or not.



Important

With this release, App-based Tethering Detection is introduced only for Netflix and YouTube.

Licensing

This feature requires both ADC, and Tethering Detection License. Contact your Cisco account representative for detailed information on specific licensing requirements. For information on installing and verifying licenses, refer to the *Managing License Keys* section of the *Software Management Operations* chapter in the *System Administration Guide*.

Configuring App-based Tethering Detection

This section describes how to enable support for App-based Tethering Detection.

Enabling App-based Tethering Detection at Rulebase Level

Use the following commands to enable App-based Tethering Detection for ADC traffic under ACS Rulebase Configuration Mode:

```
configure
  active-charging service service_name
    rulebase rulebase_name
      tethering-detection application
    exit
  exit
exit
```

Notes:

- The **default tethering-detection** command configures its default setting.

Default: By default, the Tethering Detection feature is disabled. When enabled, unless a specific database is specified to be used, tethering detection will make use of both the databases by default.

- If previously configured, use the **no tethering-detection** command to remove the tethering detection configuration from the rulebase.

Enabling App-based Tethering Detection at Ruledef Level

Use the following commands to enable App-based Tethering Detection for ADC traffic under ACS Ruledef Configuration Mode:

```
configure
  active-charging service service_name
    ruledef ruledef_name
      tethering-detection application flow-tethered
    exit
  exit
exit
```

Notes:

- If previously configured, use the **no tethering-detection** command to remove the tethering detection configuration from the ruledef.

Enabling App-based Tethering Detection at Rule-variable

Use the following commands to enable App-based Tethering Detection field in EDRs under EDR Format Configuration Mode:

```
configure
  active-charge service service_name
   edr-format format_name
      rule-variable flow tethered-application priority priority
    exit
  exit
exit
```

Notes:

- *flow tethered-application*: The *flow* specifies Flow related fields. *tethered-application* specifies application based tethering detected on flow.
- **priority *priority***: Specifies the CSV position of the field (protocol rule) in the EDR. *priority* must be an integer from 1 through 65535.
- If previously configured, use the **no rule-variable *rule_variable* [**priority *priority***]** command to remove the specified rule variable configuration.

Monitoring and Troubleshooting the App-based Tethering Detection

This section provides information regarding commands available to monitor and troubleshoot the App-based Tethering Detection.

Show Commands and Outputs

This section provides information regarding show commands and their outputs in support of this enhancement.

show active-charging tethering-detection statistics

The following fields are available in the output of this show command in support of this enhancement:

```

Current Tethered Subscribers: 0
Total flows scanned: 0
Total Tethered flows detected: 0
Total Tethered flows recovered: 0
Total flows bypassed for scanning : 0

Tethering Detection Statistics (os-ua):
  TAC ID lookups: 0
  TAC ID matches: 0
  OS signature lookups: 0
  OS signature matches: 0
  IPv6 OS signature lookups: 0
  IPv6 OS signature matches: 0
  UA signature lookups: 0
  UA signature matches: 0
  Total flows scanned: 0
  Tethered flows detected: 0
  Non-tethered flows detected: 0
  Tethered Uplink Packets: 0
  Tethered Downlink Packets: 0
  Current tethering-detected indications sent: 0
  Total tethering-detected indications sent: 0

Tethering Detection Statistics (ip-ttl):
  Total flows scanned: 0
  Tethered flows detected: 0
  Tethered uplink packets: 0
  Tethered downlink packets: 0

Tethering Detection Statistics (DNS Based):
  Total flows scanned: 0
  Tethered flows detected: 0
  Tethered uplink packets: 0
  Tethered downlink packets: 0

Tethering Detection Statistics (Application):
  Total flows scanned: 0
  Tethered flows detected: 0
  Tethered uplink packets: 0
  Tethered downlink packets: 0

```

Change Statistics for Multiple SYN in Flow:

```

Tethered to Non-Tethered:           0
Non-Tethered to Tethered:         0
Tethered to Tethered:             0
Non-Tethered to Non-Tethered:     0

```

show active-charging rulebase statistics

The following fields are available in the output of this show command in support of this enhancement:

```

Tethering Detection:
  TAC ID lookups:                0
  TAC ID matches:                0
  OS signature lookups:          0
  OS signature matches:          0
  IPv6 OS signature lookups:     0
  IPv6 OS signature matches:     0
  UA signature lookups:          0
  UA signature matches:          0
  Total flows scanned:           0
  Tethered flows detected:       0
  Tethered uplink packets:       0
  Tethered downlink packets:     0

Tethering Detection (ip-ttl):
  Total flows scanned:           0
  Tethered flows detected:       0
  Tethered uplink packets:       0
  Tethered downlink packets:     0

Tethering Detection (DNS Based):
  Total flows scanned:           0
  Tethered flows detected:       0
  Tethered uplink packets:       0
  Tethered downlink packets:     0

Tethering Detection (Application):
Total flows scanned:                0
Tethered flows detected:            0
Tethered uplink packets:           0
Tethered downlink packets:         0

```



CHAPTER 4

Peer-to-Peer Protocol and Application Detection Support

This appendix lists all the protocols and applications currently supported by Cisco ASR 5500 ADC.

- [Supported Protocols and Applications, on page 35](#)

Supported Protocols and Applications

This section lists all the supported P2P protocols, sub-protocols, and the applications using these protocols.



Important

Please note that various client versions are supported for the protocols. The client versions listed in the table below are the latest supported version(s).



Important

Please note that the release version in the **Supported from Release** column has changed for protocols/applications that are new since the ADC plugin release in August 2015. This will now be the ADC Plugin Build number in the *x.xxx.xxx* format. The previous releases were versioned as 1.1 (ADC plugin release for December 2012), 1.2 (ADC plugin release for April 2013), and so on for consecutive releases.

New in this Release

This section lists the supported P2P protocols, sub-protocols and applications introduced in the ADC Plugin release for January 31, 2019.

Protocol / Application	Client	Client Version	Group	Classification	Supported from Release
Ohio FM	Ohio FM(Android)	—	Streaming	Unclassified Streaming-audio Streaming-video	ADC Plugin 2.31.1033
	Ohio FM (iOS)	—			
	Ohio FM (Web)	—			

Protocol / Application	Client	Client Version	Group	Classification	Supported from Release
Radio.com	Radio.com (Android)	7.16.3	Streaming	Unclassified	ADC Plugin 2.31.1033
	Radio.com (iOS)	7.16.10		Streaming-audio	
	Radio.com (Web)	—		Streaming-video	
Soma FM	Soma FM (Android)	—	Streaming	Streaming-audio	ADC Plugin 2.31.1033
	Soma FM (iOS)	—		Unclassified	
	Soma FM (Web)	—			
My Mixtapez	My Mixtapez (Android)	7.8.5	Streaming	Streaming-audio	ADC Plugin 2.31.1033
	My Mixtapez (iOS)	7.5.6		Streaming-video	
	My Mixtapez (Web)	—		Unclassified	
Jango	Jango (Android)	6.3.5	Streaming	Streaming-audio	ADC Plugin 2.31.1033
	Jango (iOS)	5.4.4		Unclassified	
	Jango (Web)	—			

All Supported Protocols and Applications

This section lists all the supported P2P protocols, sub-protocols and applications supported until ADC Plugin release on December 3, 2018.

Protocol / Application	Client	Client Version	Group	Classification	Supported from Release
120Sports	120Sports (Android)	1.6	Streaming	Streaming-video	ADC Plugin 2.21.912
	120Sports (iOS)	1.8.9		Unclassified	
	120Sports (Windows)	—			

Protocol / Application	Client	Client Version	Group	Classification	Supported from Release
6Play	6play (Android)	4.4.1	Streaming	Streaming-video Unclassified	ADC Plugin 2.19.895
	6play (iOS)	4.4.1			
	6play (Windows)	—			
Abcnetworks	Abcnetworks (Android)	3.1.18.417	Streaming	Streaming-audio Streaming-video Unclassified	ADC Plugin 2.11.833
	Abcnetworks (iOS)	5.0.13			
	Abcnetworks (Windows)	—			
	Disney Channel (Android)	3.16.0			
	Disney Channel (iOS)	5.6.1			
	Disney Channel (Windows)	—			
	Disney XD (Android)	3.16.0			
	Disney XD (iOS)	5.6.1			
	Disney XD (Windows)	—			
	Disney Junior (Android)	3.16.0			
	Disney Junior (iOS)	5.6.1			
	Disney Junior (Windows)	—			
	ABSCBN	ABSCBN(Android)			
ABSCBN (iOS)		10.3.3			
ABSCBN (Web)		—			

Protocol / Application	Client	Client Version	Group	Classification	Supported from Release
Accuradio	Accuradio (Android)	1.57	Streaming	Streaming-audio Unclassified	ADC Plugin 2.2.719
	Accuradio (iOS)	2.32			
	Accuradio (Windows)	—			
ActiveSync	—	—	Business	—	Pre StarOS 12.0
ActionVoip	ActionVoip (Android)	4.01	Communicator	Audio Unclassified	1.2
	ActionVoip (iOS)	1.0			
	ActionVoip (Windows)	4.13			
Adobe Connect	Adobe Connect (Android)	2.1.2	Business	—	1.4
	Adobe Connect (iOS)	2.1			
	Adobe Connect (Windows)	9.0.4			

Protocol / Application	Client	Client Version	Group	Classification	Supported from Release	
AENetworks	A&E (Android)	2.2.0	Streaming	Streaming-video Unclassified	ADC Plugin 2.1.701	
	A&E (iOS)	2.6.0			ADC Plugin 2.28.990	
	A&E (Windows)	—				
	Lifetime (Android)	3.1.3				
	Lifetime (iOS)	3.8.4				
	Lifetime (Windows)	—				
	Lifetime Movie Club (Android)	2.3.3				ADC Plugin 2.28.990
	Lifetime Movie Club (iOS)	3.3.3				
	Lifetime Movie Club (Windows)	—				
	History (Android)	2.3.2				ADC Plugin 2.5.771
	History (iOS)	2.6.4				
	History (Windows)	—				
	History Vault (Android)	1.2.0		—	ADC Plugin 2.9.813	
	History Vault (iOS)	2.2				
	History Vault (Windows)	—		—	—	
	FYI (Android)	—				
	FYI (iOS)	—				
	FYI (Web)	—		—	ADC Plugin 2.28.990	
Aimini	—	—	File Sharing	—	Pre StarOS 12.0	

Protocol / Application	Client	Client Version	Group	Classification	Supported from Release
AmazonCloud	AmazonCloud (Android)	3.5.0	Cloud	—	1.2
	AmazonCloud (iOS)	3.9.0.0			
	AmazonCloud (Windows)	1.5.0			
Amazon Music	AmazonMusic (Android)	4.6.5.60050	Streaming	—	ADC Plugin 1.141.522
	AmazonMusic (iOS)	3.1.0			
	AmazonMusic (Windows)	—			
Amazon Video	Amazon Video (Android)	3.0.57	Streaming	Streaming-video Unclassified	ADC Plugin 1.146.551
	Amazon Video (iOS)	3.30.13182			
Android Messages for Web	Android Messages for Web (Android)	3.5.053		Unclassified	ADC Plugin 2.28.990
	Android Messages for Web (iOS)	—			
	Android Messages for Web (Web)	—			
AntsP2P	AntsP2P	1.6.0	Peer to Peer Anonymous File Sharing	—	StarOS 12.0
AnyConnect	AnyConnect (Android)	4.0.05054	Internet Privacy	—	ADC Plugin 2.1.701
	AnyConnect (iOS)	4.0.05055			
	AnyConnect (Windows)	4.1.06020			
Apple-store	App store (iOS)	2.9.2	E-store	—	1.9

Protocol / Application	Client	Client Version	Group	Classification	Supported from Release
AppleJuice	AppleJuice	0.31.149.110	Peer to Peer File Sharing	—	Pre StarOS 12.0
Apple Maps	Apple Maps (iOS)	7	Untagged	—	1.6
	Web	—			
Apple Push	Apple Push Notification (iOS)	—	Untagged	Unclassified	1.10
Ares	Ares	2.1.8	Peer to Peer File Sharing	—	Pre StarOS 12.0
	KCEasy	—			
Armagettron	—	—	Gaming	—	Pre StarOS 12.0
AVI	—	—	Streaming	—	1.1
Badoo	Badoo (Android)	4.1.10	Social Network - Generic	—	1.6
	Badoo (BlackBerry)	2.23.1			
	Badoo (iOS)	3.19.0			
Baeble Music	Baeble Music (Android)	1.11.22	Streaming	Streaming-video Unclassified	ADC Plugin 2.21.912
	Baeble Music (iOS)	7.8.0			
	Baeble Music (Window)	—			
Baidumovie	Baidumovie (Android)	4.5.3	Streaming	—	1.5
	Baidumovie (iOS)	2.4.5			
	Baidumovie (Windows)	3.2			
	Web	—			
Bandcamp	Bandcamp(Android)	2.1.5	Streaming	Streaming-audio Streaming-video Unclassified	ADC Plugin 2.29.1008
	Bandcamp (iOS)	2.1.4			
	Bandcamp (Web)	—			

Protocol / Application	Client	Client Version	Group	Classification	Supported from Release
Battlefield	—	—	Gaming	—	Pre StarOS 12.0
BBM	BBM (Android)	1.0.3.87	Communicator	Unclassified	1.7
	BBM (iOS)	1.0.5.134		Audio	
Betternet VPN	Betternet VPN (Android)	3.8.5	Internet Privacy	—	ADC Plugin 2.11.833
	Betternet VPN (iOS)	3.3.18			
	Betternet VPN (Windows)	—			
Bitcasa	Bitcasa (Android)	2.0	Cloud	—	1.5
	Bitcasa (iOS)	2.0.1			
	Bitcasa (Windows)	1.1.2.11			
	Web	—			
Beatport	Beatport (Android)	1.1.0.2	Streaming	—	ADC Plugin 2.19.895
	Beatport (iOS)	2.4.0			
	Beatport (Windows)	—			
BFM TV	BFM TV (Android)	3.0.9	Streaming	Streaming-video	ADC Plugin 2.19.895
	BFM TV (iOS)	5.0.7		Unclassified	
	BFM TV (Windows)	—			

Protocol / Application	Client	Client Version	Group	Classification	Supported from Release
Bittorrent	ABC	3.1_02	Peer to Peer File Sharing	—	Pre StarOS 12.0
	Acquisition	—			
	Anatomic P2P	—			
	Arctic Torrent	—			
	Azureus / Vuze (Windows)	5.0			
	Azureus / Vuze (MAC)	1.2.0.2			
	BitComet	1.36			
	BitFlu	—			
	BitLord	2.2			
	BitPump	—			
	BitRocket	0.3.3			
	Bits on Wheels	—			
	BitSpirit	3.6			
	BitTornado	0.3.1.8			
	BitTorrent (MAC)	7.4.1			
	BitTorrent	7.9.2.32895			
	BitTyrant	—			
	Blizzard Downloader	—			
	Blog Torrent - BTG	—			
	BtManager	—			
	BTSharp	—			
	burst!	—			
CTorrent	—				
Deluge	—				

Protocol / Application	Client	Client Version	Group	Classification	Supported from Release
	FlashGet	3.7.0.1203			
	Freeloader	—			
	FrostWire	5..6.9			
	G3 Torrent	—			
	Gnome BitTorrent	—			
	Halite	—			
	KTorrent	4.1.3			
	LimeWire	5.4.6			
	Localhost	—			
	MLDonkey	—			
	MonoTorrent	—			
	MooPolice	—			
	MovieTorrent	4.8.0.0			
	OneSwarm	0.6			
	Opera	—			
	QBittorrent	—			
	QTorrent	—			
	rTorrent	—			
	Rufus	—			
	Shareaza	—			
	Sharktorrent	—			
	SymTorrent	—			
	Tomato Torrent	—			
	Torrent Swapper	—			
	TorrentFlux	—			
	TorrentSpy	—			
	TorrentVolve	—			

Protocol / Application	Client	Client Version	Group	Classification	Supported from Release
	Transmission	1.8			
	Transmission (Mac)	2.82			
	Tribbler	—			
	Turbo Torrent	—			
	utorrent (MAC)	0.9.1.2			
	Warez	3.2.0			
	WizBit	—			
	WMTorrent (Windows Mobile)	—			
	Xtorrent (Mac)	2.1			
	ZipTorrent	—			
	µTorrent	3.4.2.32891			
	µTorrent (Mac)	1.5.2			
Bittorrent-sync	Bittorrent-sync (Android)	1.2.14	Cloud	—	1.8
	Bittorrent-sync (iOS)	1.2.47			
	Bittorrent-sync (Web)	—			
	Bittorrent-sync (Windows Phone)	1.3.14			
Blackberry	—	—	Business	Audio Unclassified	12.0
Blackberry-store	Blackberry World (BB)	5.0.0.131	E-store	—	1.9
Blackdialer	Blackdialer (Windows)	1.0.11	Communicator	Audio Unclassified	1.4

Protocol / Application	Client	Client Version	Group	Classification	Supported from Release
BlackPlanet Radio	BlackPlanet Radio (Android)	5.1.15.22	Streaming	Streaming-audio Unclassified	ADC Plugin 2.2.719
	BlackPlanet Radio (iOS)	5.1.21			
	BlackPlanet Radio (Windows)	—			
Box	Box (Android)	2.3.0	Cloud	—	1.7
	Box (iOS)	2.8.7			
	Box (BB)	1			
	Box (Windows Phone)	1.6.4.1921			
	Box (Web)	—			
Btn	Btn (Android)	7.0825	Streaming	Streaming-video Unclassified	ADC Plugin 2.22.939
	Btn (iOS)	6.8			
	Btn (Windows)	—			
Call Of Duty	Call Of Duty (Android)	4.1.1	Gaming	—	StarOS 14.0
	Call Of Duty (iOS)	4.1.1			
Cbs Sports	Cbs Sports (Android)	9.6.3.2	Streaming	Streaming-video Unclassified	ADC Plugin 2.22.939
	Cbs Sports (iOS)	10.6.1			
	Cbs Sports (Window)	—			
Chikka	Chikka mail (Android)	1.4.4	E-mail	Unclassified	1.7
	Chikka mail (iOS)	2.4			
	Chikka mail (Web)	—			

Protocol / Application	Client	Client Version	Group	Classification	Supported from Release
Cisco Jabber Important ADC detection: Cisco Jabber support is only provided for Cisco Jabber Video for Telepresence. Cisco Jabber Communicator or Webex meetings will be detected as Webex by ADC.	Cisco Jabber (Android)	12.5.0.272870	Business	Audio	ADC Plugin 2.29.1008
	Cisco Jabber (iOS)	12.1.2		Video	
	Cisco Jabber (Windows)	4.6.3		Unclassified	
Citrix	—	—	Business	—	Pre StarOS 12.0
Clash Royale	Clash Royale (Android)	2.4.3	Gaming	Unclassified	ADC Plugin 2.28.990
	Clash Royale (iOS)	2.4.2			
	Clash Royale (Windows)	—			
Clubbox	Clubbox (Windows)	2.2.4.8	File Sharing	—	1.5
	Web	—			
ClubPenguin	—	—	Gaming	—	Pre StarOS 12.0
Comodo EasyVPN	Comodo	3.0.2.0	Internet Privacy	—	StarOS 14.0
Crackle	Crackle (Android)	4.4.5.0	Streaming	Streaming-video	ADC Plugin 1.145.545
	Crackle (iOS)	4.4.1		Unclassified	
CrossFire	—	—	Gaming	—	Pre StarOS 12.0

Protocol / Application	Client	Client Version	Group	Classification	Supported from Release
Crunchyroll	Crunchyroll (Android)	2.0.11	Streaming	Streaming-video Unclassified	ADC Plugin 2.5.771
	Crunchyroll (iOS)	3.00.4			
	Crunchyroll (Windows)	—			
Curiosity Stream	Curiosity Stream (Android)	2.2.4	Streaming	Streaming-video Unclassified	ADC Plugin 1.157.618
	Curiosity Stream (iOS)	2.1.4			
Custo Justo	Custo Justo (Android)	12.0.2.0	estore	Unclassified	ADC Plugin 2.29.1008
	Custo Justo (iOS)	12.0.2			
	Custo Justo (Web)	—			
CyberGhost VPN	CyberGhost (Android)	6.0.65	Internet Privacy	—	1.4
	CyberGhost (iOS)	6.7.0			
	CyberGhost (MAC)	5.0.14.12			
	CyberGhost (Windows)	6.0.5.2405			

Protocol / Application	Client	Client Version	Group	Classification	Supported from Release
Dailymotion	Dailymotion (Android)	9498	Streaming	Streaming-video Unclassified	ADC Plugin 2.4.739
	Dailymotion (iOS)	5.6.10			
	Dailymotion (Windows)	—			
	Dailymotion Games (Android)	1.2.1			
	Dailymotion Games (iOS)	1.2			
	Dailymotion Games (Windows)	—			
Danzwave	Danzwave (Android)	1.01	Streaming	Streaming-audio Unclassified	ADC Plugin 2.28.990
	Danzwave (iOS)	3.3			
	Danzwave (Web)	—			
	PreDanz (Android)	—			
	PreDanz (iOS)	—			
	PreDanz (Web)	—			
	RadioDanz (Android)	—			
	RadioDanz (iOS)	—			
	RadioDanz (Web)	—			
	Chilltrax (Android)	—			
	Chilltrax (iOS)	—			
	Chilltrax (Web)	—			

Protocol / Application	Client	Client Version	Group	Classification	Supported from Release
Dashradio	Dashradio (Android)	4.0	Streaming	Streaming-audio Unclassified	ADC Plugin 2.28.990
	Dashradio (iOS)	4.4			
	Dashradio (Web)	—			
Datpiff	Datpiff(Android)	4.7.3	Streaming	Streaming-audio Unclassified	ADC Plugin 2.29.1008
	Datpiff (iOS)	4.7.3			
	Datpiff (Web)	—			
Deezer	Deezer (Android)	5.4.2.129	Streaming	Streaming-audio Unclassified	ADC Plugin 2.5.771
	Deezer (iOS)	6.16.0			
	Deezer (Windows)	—			
DiDi	DiDi (Android)	1.4.3	Communicator	Audio	1.10
	DiDi (iOS)	1.4.4		Unclassified	

Protocol / Application	Client	Client Version	Group	Classification	Supported from Release
Digitally Imported	Digitally Imported (Android)	4.3.4.6249	Streaming	Streaming-audio Unclassified	ADC Plugin 2.29.1008
	Digitally Imported (iOS)	4.3.0			
	Digitally Imported (Web)	—			
	Classical Radio (Android)	4.3.4.6249			
	Classical Radio (iOS)	4.3.0			
	Jazz Radio (Android)	4.3.4.6249			
	Jazz Radio (iOS)	4.3.0			
	Radio Tunes (Android)	4.3.4.6249			
	Radio Tunes (iOS)	4.3.0			
	Rock Radio (Android)	4.3.4.6249			
	Rock Radio (iOS)	4.3.0			
	Digitally Imported (Android)	4.3.4.6249			
Direct Download Link (DDL)	turbobit.net	—	File Sharing	—	Pre StarOS 12.0
	filesonic.in	—			
	4shared.com	—			
	DDLlink (iOS)	2.0.7			

Protocol / Application	Client	Client Version	Group	Classification	Supported from Release
DirectConnect	AirDC	2.22	Peer to Peer File Sharing	—	Pre StarOS 12.0
	ApexDc++	1.5.1			
	BCDC++	0.782			
	CZDC	—			
	DC#	—			
	dc_gui/HUB	0.2.19			
	DC++	0.843			
	dctc	—			
	Dolda Connect	—			
	Elise	—			
	fulDC	—			
	GtkDC	—			
	iDC	2.03			
	ldcc	—			
	LinuxDC++	—			
	microdc	—			
	microdc2	—			
	oDC	—			
	Revconnect	0.674p			
	SababaDC	—			
ShakesPeer	—				
StrongDC++	—				
Valknut	—				
ZDc++	0.668z				
DirecTV	DirecTV (Android)	4.6.008	Streaming	Streaming-video Unclassified	ADC Plugin 2.0.683
	DirecTV (iOS)	4.6.009			

Protocol / Application	Client	Client Version	Group	Classification	Supported from Release
Discord	Discord (Android)	3.0.2	Communicator	—	ADC Plugin 2.1.701
	Discord (iOS)	1.7.3			
	Discord (Windows)	—			
Dish Anywhere	Dish Anywhere (Android)	4.4.73	Streaming	—	ADC Plugin 1.150.572
	Dish Anywhere (iOS)	6.5.24			
Disney Movies Anywhere	Disney Movies Anywhere (Android)	1.8.2	Streaming	Streaming-video Unclassified	ADC Plugin 2.14.860
	Disney Movies Anywhere (iOS)	1.7.7			
	Disney Movies Anywhere (Windows)	—			
Dofus	—	—	Gaming	—	Pre StarOS 12.0
DPAN TV	DPAN TV (Android)	—	Streaming	Unclassified	ADC Plugin 2.19.895
	DPAN TV (iOS)	—			
	DPAN TV (Browser only)	—			
DramaFever	DramaFever (iOS)	3.5.1	Streaming	Streaming-video Unclassified	ADC Plugin 2.9.813
	DramaFever (Windows)	—			
	DramaFever (Android)	1.1.46			

Protocol / Application	Client	Client Version	Group	Classification	Supported from Release
Dropbox	Dropbox (Android)	2.5.0.4	Cloud	—	1.5
	Dropbox (MAC)	2.6.2			
	Dropbox (iOS)	3.8.1			
	Dropbox (Windows)	2.8.3			
eBuddy	eBuddy (Android)	2.21.2	Untagged	—	StarOS 14.0
	eBuddy (iOS)	2.3			
	eBuddy (Web)	—			
	eBuddy (Windows Phone)	3.5.1.0			
eDonkey	aMule	2.2.5	Peer to Peer File Sharing	—	Pre StarOS 12.0
	amule (MAC)	—			
	eDonkey2000	—			
	eMule and its Mods	0.50.97			
	eMule Plus	—			
	Hydranode	—			
	iMule	1.2.5			
	Jubster	—			
	Lphant	—			
	MLDonkey	2.9.6			
	MLDonkey (MAC)	3.0.0			
	Morpheus	—			
	obfuscated eMule ext.	—			
	Shareaza	2.5.5.0			
xMule	—				

Protocol / Application	Client	Client Version	Group	Classification	Supported from Release
Epix	Epix (Android)	1.335.20180418	Streaming	Streaming-video Unclassified	ADC Plugin 2.26.968
	Epix (iOS)	3.7.2			
	Epix (Web)	—			
Eros Now	Eros Now (Android)	3.7.8	Streaming	Streaming-audio Streaming-video Unclassified	ADC Plugin 2.23.953
	Eros Now (iOS)	3.8			
	Eros Now (Windows)	—			
ESNE	ESNE (Android)	1.0.1	Streaming	Streaming-audio Streaming-video Unclassified	ADC Plugin 2.4.739
	ESNE (iOS)	1.3			
	ESNE (Windows)	—			
ESPN	ESPN (Android)	4.7	Streaming	Streaming-video Unclassified	ADC Plugin 1.145.545
	ESPN (iOS)	1.6.1			
ESPN Radio	ESPN Radio (Android)	5.6.1	Streaming	Streaming-audio Unclassified	ADC Plugin 2.5.771
	ESPN Radio (iOS)	5.6.2			
	ESPN Radio (Windows)	—			
ExpressVPN	ExpressVPN (Android)	6.4.1	Internet Privacy	—	ADC Plugin 2.11.833
	ExpressVPN (iOS)	6.5.5			
	ExpressVPN (Windows)	—			

Protocol / Application	Client	Client Version	Group	Classification	Supported from Release
Facebook	Facebook (Android)	151.0.0.44.205	Social Network - Generic	Audio	Pre StarOS 12.0
	Facebook (Blackberry)	10.2.2.6		Streaming-video	
	Facebook (iOS)	150.0		Unclassified	
	Facebook (Web)	—			
	Facebook Messenger (Android)	141.0.0.31.76			1.6
	Facebook Messenger (iOS)	142.0			
	Facebook Watch (Android)	—		Streaming-video	ADC Plugin 2.28.990
	Facebook Watch (iOS)	—			
	Facebook Watch (Web)	—			
FaceTime	FaceTime (iOS)	9.0.2	Communicator	Audio	Pre StarOS 12.0
	FaceTime (MAC)	3		Video	
				Unclassified	
FandangoNow	FandangoNow (Android)	2.8.2	Streaming	Streaming-video	ADC Plugin 2.4.739
	FandangoNow (iOS)	2.2.1		Unclassified	
	FandangoNow (Windows)	—			
Fandor	Fandor (Android)	1.5.1	Streaming	Streaming-video	ADC Plugin 1.152.582
	Fandor (iOS)	2.7.04		Unclassified	

Protocol / Application	Client	Client Version	Group	Classification	Supported from Release
FastTrack	Apollon	—	Peer to Peer File Sharing	—	Pre StarOS 12.0
	Grokster	—			
	Kazaa	3.2.7			
	Kazaa Lite	—			
	KCeasy	—			
	k-lite	v2.7			
	MLDonkey	—			
Feidian	—	—	Streaming	—	Pre StarOS 12.0
Ficall	—	—	Communicator	—	StarOS 14.0
Fiesta	—	—	Gaming	—	Pre StarOS 12.0
Filetopia	Filetopia	3.04.100	Peer to Peer File Sharing	—	Pre StarOS 12.0
FilmOn TV	FilmOn TV (Android)	2.4.3	Streaming	Streaming-video Unclassified	ADC Plugin 2.14.860
	FilmOn TV (iOS)	2.0.39			
	FilmOn TV (Windows)	—			
	OVGuide (Android)	—			ADC Plugin 2.28.990
	OVGuide (iOS)	—			
	OVGuide (Web)	—			
Fit Radio	Fit Radio (Android)	2017.12.11.1830	Streaming	Streaming-audio Unclassified	ADC Plugin 2.23.953
	Fit Radio (iOS)	2017.12.11.1830			
	Fit Radio (Window)	—			
Flash	—	—	Standard	Streaming-video Unclassified	Pre StarOS 12.0

Protocol / Application	Client	Client Version	Group	Classification	Supported from Release
Flickr	Flickr (Android)	4.0.7	File Sharing	—	1.5
	Flickr (iOS)	4.0.7			
	Flickr (Windows Mobile)	2.1.0.0			
	Web	—			
Flixsea	Flixsea (Android)	11.0.2	Streaming	Streaming-video Unclassified	ADC Plugin 2.23.953
	Flixsea (iOS)	9.0.1			
	Flixsea (Windows)	—			
Florensia	—	—	Gaming	—	Pre StarOS 12.0
Foursquare	Foursquare (Android)	013.10.29	Social Network - Generic	—	1.6
	Foursquare (iOS)	6.4.1			
	Foursquare (Windows)	3.1.3			
	Web	—			
Fox Business	Fox Business (Android)	3.0	Streaming	Streaming-video Unclassified	ADC Plugin 2.0.683
	Fox Business (iOS)	3.0			
Fox News	Fox News (Android)	2.1.8	Streaming	Streaming-video Unclassified	ADC Plugin 2.0.683
	Fox News (iOS)	2.2.6			
	Fox News (Windows)	—			
	Fox News Live TV (Android)	2.6.5			ADC Plugin 2.11.833
	Fox News Live TV (iOS)	2.6.6			
	Fox News Live TV (Windows)	—			

Protocol / Application	Client	Client Version	Group	Classification	Supported from Release
FoxNow	FoxNow (Android)	2.10.1	Streaming	Streaming-video Unclassified	ADC Plugin 2.2.719
	FoxNow (iOS)	2.16.3			
	FoxNow (Windows)	—			
FOX Sports	FOX Sports (Android)	3.5.10	Streaming	Streaming-video Unclassified	ADC Plugin 1.150.572
	FOX Sports (iOS)	3.5.11			
Fox Sports Go	Fox Sports Go (Android)	3.6.0	Streaming	Streaming-audio Unclassified	ADC Plugin 2.22.939
	Fox Sports Go (iOS)	3.6.1			
	Fox Sports Go (Windows)	—			
France TV	France TV (Android)	7.0.0	Streaming	Streaming-video Unclassified	ADC Plugin 2.19.895
	France TV (iOS)	6.0.2			
	France TV (Windows)	—			
Freenet	Freenet	0.7.5	Peer to Peer Anonymous File Sharing	—	Pre StarOS 12.0
Friendster	Friendster (Windows)	—	Social-nw-gaming	Unclassified	1.10
Fring	Fring (Android)	4.5.1	Communicator	—	Pre StarOS 12.0
	Fring (iOS)	6.5			
	Fring (Symbian)	3.36			
	Fring (Windows)	1.1.0.4			
Fubo TV	Fubo TV (Android)	2.2.0	Streaming	Streaming-video Unclassified	ADC Plugin 1.157.618
	Fubo TV (iOS)	2.0.7.1506			

Protocol / Application	Client	Client Version	Group	Classification	Supported from Release
Funshion	Funshion (Android)	1.7.2.2	Streaming	—	Pre StarOS 12.0
	Funshion (iOS)	1.2.9.2			
	Funshion (Windows)	2.8.6			
	Web	—			
FxNow	FxNow (Android)	1.9	Streaming	Streaming-video Unclassified	ADC Plugin 2.2.719
	FxNow (iOS)	1.9			
	FxNow (Windows)	—			
Gaana	Gaana (Android)	7.8.3.1	Streaming	Streaming-audio Unclassified	ADC Plugin 2.21.912
	Gaana (iOS)	5.0.7			
	Gaana (Windows)	—			
Gadu-Gadu	GaduGadu (Android)	3.9.2	Communicator	Audio File Transfer Video Unclassified	Pre StarOS 12.0
	GaduGadu (iOS)	3.11.1			
	GaduGadu (Windows)	11.2.35.10307			
	Miranda	0.9.38			
GameKit	iPhone4	—	Social Network Gaming	—	Pre StarOS 12.0

Protocol / Application	Client	Client Version	Group	Classification	Supported from Release
Gnutella	Acqlite	—	Peer to Peer File Sharing	—	Pre StarOS 12.0
	Acquisition	—			
	Apollon	—			
	BearShare	8.1			
	BearShareLite	5.2.5			
	Cabos	—			
	CocoGnut	—			
	DM2	—			
	Foxy	1.9.10			
	FrostWire	5.3.2			
	gift	—			
	Gluz	—			
	Gnucleus	2.0.2.0			
	Gtk-gnutella	—			
	KCeasy	—			
	Kiwi Alpha	—			
	LimeWire	5.4.6			
	MLDonkey	—			
	Morpheus	7.0.x			
	Mutella	—			
	Phex	3.4.2.116			
	Poisoned	—			
	Qtella	—			
	Shareaza	2.5.5.0			
	Swapper.NET	—			
Symella	—				
Turbo	—				

Protocol / Application	Client	Client Version	Group	Classification	Supported from Release
	XFactor	—			
	XNap	—			
	XoloX	—			
Go90	Go90 (Android)	2.11.0.99297	Streaming	—	ADC Plugin 1.144.540
	Go90 (iOS)	2.11.1			
Goober	Goober	3.0.0.9	Communicator	—	StarOS 14.0
	Goober (iOS)	2.0			
Google	Google Drive (Android)	2.1.495	Standard	—	1.4
	Google Drive (iOS)	3.5.0			
	Google Drive (Windows)	1.10.4769.0632			
	Google Latitude (Android)	2.8			
	Google Latitude (iOS)	2.2.1			
	Google Maps (Android)	9.4.0			
	Important Traffic originating from the Android version of Google Maps will be detected as Google.				
	Google Maps (iOS)	4.4.0			
	google search (iOS)	4.1.0			
	Web	—			

Protocol / Application	Client	Client Version	Group	Classification	Supported from Release
Google Maps	Google Maps (Android)	9.77.2	Streaming	Unclassified	ADC Plugin 2.23.953
	Google Maps (iOS)	—			
	Google Maps (Windows)	—			
Google Music	Google Music (Android)	6.9.2920	Streaming	Unclassified	1.10
	Google Music (iOS)	3.10.1005			
	Google Music (Web)	—			
Google Push	Google Push Notification (Android)	—	Untagged	Unclassified	1.10
Gmail	Gmail (Android)	4.9	Email	—	Pre StarOS 12.0
	Important Traffic originating from this Android version of Gmail will be detected as Google.				
	Gmail (iOS)	2.71828			
	Gmail (Web)	—			
Google Play	Google Play (Android)	5.9.12	E-store	—	1.1
Google+	Googleplus (Android)	5.3.0.91	Social Network - Generic	—	1.4
	Important Traffic originating from Google+ will be detected as Google.	Googleplus (iOS)			

Protocol / Application	Client	Client Version	Group	Classification	Supported from Release
Google Talk/ Hangouts	Hangouts (Android)	2.5.83	Communicator	Audio File Transfer Video Unclassified	Pre StarOS 12.0
	Hangouts (iOS)	2.5.13			
	Web	—			
Gotomeeting	Gotomeeting (Android)	5.0.799.1288	Business	—	StarOS 14.0
	Gotomeeting (iOS)	6.3.0.557			
	Gotomeeting (Windows)	5.3.970			
GuildWars	—	—	Gaming	—	Pre StarOS 12.0
Half-Life 2 and Mods	—	—	Gaming	—	Pre StarOS 12.0
HamachiVPN	Hamachi (Windows)	2.2.0.227	Internet Privacy	—	Pre StarOS 12.0
Hayu	Hayu (Android)	1.1.4	Streaming	Streaming-video Unclassified	ADC Plugin 2.14.860
	Hayu (iOS)	1.25			
	Hayu (Windows)	—			
HBO Go	hbogo (Android)	4.3.2.11	Streaming	Unclassified	1.12
	hbogo (iOS)	2.5.0			
	hbogo (Windows)	—			
HBO NOW	HBONOW (Android)	1.3.0	Streaming	Streaming-video Unclassified	ADC Plugin 1.145.545
	HBONOW (iOS)	1.4.0.2984			
HBO Nordic	HBO Nordic (Android)	2.2.0	Streaming	Streaming-video Unclassified	ADC Plugin 2.22.939
	HBO Nordic (iOS)	4.1.1			
	HBO Nordic (Windows)	—			

Protocol / Application	Client	Client Version	Group	Classification	Supported from Release
HexaTech VPN	HexaTech VPN (Android)	1.8.6	Internet Privacy	—	ADC Plugin 2.11.833
	HexaTech VPN (iOS)	1.6.4			
	HexaTech VPN (Windows)	—			
Heytell	Heytell (Android)	3.1.0.384	Communicator	—	1.5
	Heytell (iOS)	3.1.2			
HGTV	HGTV Folio (Android)	—	Streaming	Streaming-video Unclassified	ADC Plugin 1.149.565
	HGTV Folio (iOS)	1.5.1			
	HGTV Watch (Android)	4.2.0			
	HGTV Watch (iOS)	6.4			
Hike-messenger	Hike-messenger (Android)	3.1.0.0	Communicator	Unclassified	1.10
	Hike-messenger (iOS)	2.5.3			
	Hike-messenger (Windows Phone)	2.6.2.0			
	Hike-messenger (Blackberry)	2.6.2			
Hls	HLS Player (Web)	2.8.7	Streaming	—	1.8
HotspotVPN	HotspotVPN (Android)	1.6	Internet Privacy	—	1.5
	HotspotVPN (iOS)	2.1.3			
	HotspotVPN (Windows)	3.20			

Protocol / Application	Client	Client Version	Group	Classification	Supported from Release
Hulu	Huluplus (Android)	3.38	Streaming	—	1.9
	Huluplus (iOS)	5.36			
	Huluplus (Windows Phone)	1.2.0.0			
Hyves	Hyves (Android)	2.1.6	Social Network - Generic	—	1.4
	Hyves (iOS)	5.0.0			
	Hyves (Windows)	2.4.6154			
	Web	—			
IAX	DiAx	—	Standard	—	Pre StarOS 12.0
	Firefly	—			
	IAXComm	—			
	IAXPhone	—			
	Idefisk	—			
	Kiax	—			
	LoudHush	—			
	PURtel	—			
	YakaPhone	—			
	ZiaxPhone	—			
iCall	iCall (Android)	0.9.34	Communicator	Audio Video Unclassified	1.2
	iCall (iOS)	2.1.4			
	iCall (Mac)	7.1.524			
	iCall (Windows)	7.1.524			
	Web	—			
Iccast	—	—	Streaming	—	Pre StarOS 12.0
iCloud	—	—	Cloud	—	1.1

Protocol / Application	Client	Client Version	Group	Classification	Supported from Release
iDrive	iDrive (Android)	3.4.5	Cloud	Unclassified	1.10
	iDrive (iOS)	2.4.9			
	iDrive (Windows Phone)	2.2.0.0			
	iDrive (Windows)	2.6.26.1.0.13			
Igo	Igo Primo (iOS)	2.5	Maps	—	1.9
iHeartRadio	iheartradio (Android)	8.4.0	Streaming	Ads Unclassified	1.12
	iheartradio (Blackberry)	1.1.2.92			
	iheartradio (iOS)	8.5.0			
	iheartradio (Windows)	—			
	iheartradio (Windows Phone)	1.1.820			
iMesh	BearFlix	—	Peer to Peer File Sharing	—	Pre StarOS 12.0
	BearShare	8.1			
	iMesh	11			
iMessage	iMessage (iOS)	6.1.3	Communicator	—	1.4
Important The IM (text) traffic will be detected as Apple Push and not as iMessage.	iMessage (MAC)	8			
Imgur	Imgur (Android)	1.3.0	Social Network - Generic	—	1.7
	Imgur (iOS)	1.2.3			
	AENetworks Imgur (Web)	—			

Protocol / Application	Client	Client Version	Group	Classification	Supported from Release
IM+	Implus (Android)	6.6.1	Communicator	—	StarOS 14.0
	Implus (iOS)	6.5			
IMO	IMO (Android)	9.8.00000008432	Communicator	—	StarOS 12.2
	IMO (iOS)	7.1.16			
	IMO (Web)	—			
Instagram	Instagram (Android)	13.0.0.7.91	Social Network - Generic	—	1.2
	Instagram (iOS)	13.0			
	IGTV (Android)	—			ADC Plugin 2.28.990
	IGTV (iOS)	—			
	IGTV (Web)	—			
	Web	—			
	<ul style="list-style-type: none"> • http://instagram/ • http://www.instagram.com/ • http://d.instagram.com/ • http://i1361.com/ • http://stinstagram.com/ • http://v.instagram.com/ • http://hasgram.com/ • http://pic.twitter.com/ • http://copygram.com/ • http://www.instagram.com/ • http://tiketgram.com/ • http://extragram.com/ 				

Protocol / Application	Client	Client Version	Group	Classification	Supported from Release
iPlayer	iPlayer (Android)	2.0.2.8	Streaming	—	StarOS 14.0
	iPlayer (Mac)	1.0.2			
	iPlayer (Windows)	3.2.15			
	Web	—			
IPTV	—	—	Streaming	—	Pre StarOS 12.0
IRC	ChatZilla	0.9.88.2	Communicator	File Transfer Unclassified	Pre StarOS 12.0
	ClickNWhistles	1.9.8			
	dIRC	2.2.0.1			
	KoroIRC	0.3			
	kvIRC	4.0.4			
	Miranda	0.9.38			
	mIRC	7.25			
	NetTalk	6.7.12			
	PhibianIRC	1.7.0			
	pidgin	2.10.4			
	pIRC	0.5b			
	TurboIRC	7			
	Xchat	2.8.9			
ISAKMP	—	—	Internet Privacy	—	Pre StarOS 12.0
ISKOOT	ISKOOT - Skype	1.1.6.0	Communicator	—	Pre StarOS 12.0
iTunes	Apple Music (Android)	1.1.2	E-store	—	12.0
	Apple Music (iOS)	9.3.1			

Protocol / Application	Client	Client Version	Group	Classification	Supported from Release
Jabber	Exodus	0.9.10	Communicator	Audio File Transfer Video Unclassified	Pre StarOS 12.0
	Gaim	—			
	Google Talk	1.0.0.104			
	iChat (MAC)	5.0.1			
	Kopete	—			
	Miranda	0.9.1.38			
	Pandion	2.6.106			
	Trillian / Trillian Pro	—			
Jap	Jap (Windows)	00.19.001	Anonymous Access	—	1.6
Jumblo	Jumblo (Android)	3.71	Communicator	Audio Unclassified	1.2
	Jumblo (iOS)	1.0			
	Jumblo (Windows)	4.12			
Kakaotalk	Kakaotalk (Android)	4.8.4	Communicator	Audio Unclassified	StarOS 14.0
	Kakaotalk (iOS)	4.6.9			
Kcrw	Kcrw (Android)	4.0.3	Streaming	Streaming-audio Streaming-video Unclassified	ADC Plugin 2.29.1008
	Kcrw (iOS)	4.0.3			
	Kcrw (Web)	—			
Kidoodle	Kidoodle (Android)	3.5.2 and 3.5.4	Streaming	Streaming-video Unclassified	ADC Plugin 1.157.618
	Kidoodle (iOS)	3.3.2			
	Kidoodle (Windows)	48.0.2564.116			

Protocol / Application	Client	Client Version	Group	Classification	Supported from Release
Kik Messenger	Kik Messenger (Android)	7.2.2.99	Communicator	Unclassified	1.10
	Kik Messenger (iOS)	7.2.1			
	Kik Messenger (Windows Phone)	2.1.0.0			
Kiswe	Kiswe (Android)	4.7.2	Streaming	Streaming-video Unclassified	ADC Plugin 2.26.968
	Kiswe (Android)	4.7.2			
	Kiswe (Web)	—			
KlowdTV	KlowdTV (Android)	2.4.8	Streaming	—	ADC Plugin 2.2.719
	KlowdTV (iOS)	2.4.8			
	KlowdTV (Windows)	—			
Kontiki	—	—	Business	—	Pre StarOS 12.0
Kugou	Kugou (Android)	7.4	Streaming	—	1.2
	Kugou (Windows)	5.1.1			
	Web	—			
Kuro	Kuro (Android)	3.9.1	Streaming	—	1.5
	Kuro (iOS)	4.0.1			
	Kuro (iPad)	4.0			
	Kuro (Windows Mobile)	1.1.0.0			
Ligonier Ministries (Under the keyword subsplash)	Ligonier Ministries (Android)	3.6.0	Streaming	Streaming-video Unclassified	ADC Plugin 2.26.968
	Ligonier Ministries (iOS)	4.9.0			
	Ligonier Ministries (Web)	—			

Protocol / Application	Client	Client Version	Group	Classification	Supported from Release
LinkedIn	LinkedIn (Android)	3.4.6	Social Network - Generic	—	1.4
	LinkedIn (BlackBerry)	10.1.5			
	LinkedIn (iOS)	8.6			
	LinkedIn (Windows Mobile)	1.1			
	Web	—			
Livestream	Livestream (Android)	4.1.7	Streaming	Streaming-video Unclassified	ADC Plugin 2.14.860
	Livestream (iOS)	4.1.5			
	Livestream (Windows)	—			
Lync	Lync (Windows)	2013	Communicator	Audio File transfer Video Unclassified	1.8
MagicJack	MagicJack (Android)	2.6.661.3	Communicator	Audio Unclassified	1.2
	MagicJack (iOS)	2.1.6213			
Manolito	Blubster	—	Peer to Peer File Sharing	—	Pre StarOS 12.0
	Manolito	3.1.1			
	Piolet	—			
Mapfactor	GPS Navigation (Android)	1.1.5	Maps	—	1.9
	Navigator Free (Android)	12.3.0			
MAPI	—	—	Email	—	1.2
MapleStory	—	—	Gaming	—	Pre StarOS 12.0

Protocol / Application	Client	Client Version	Group	Classification	Supported from Release
Meebo	Meebo (Android)	2.2	Untagged	—	StarOS 12.2
	Meebo (iOS)	1.98.14			
	Meebo (Web)	—			
Meetic	Meetic (Android)	3.25.3	Streaming	Streaming-video Unclassified	ADC Plugin 2.22.939
	Meetic (iOS)	4.9.1			
	Meetic (Windows)	—			
MGCP	—	—	Standard	—	Pre StarOS 12.0
Microsoft Office 365 Home Version	MOffice365 (Android)	1.0.1	Cloud	—	ADC Plugin 2.4.739
	MOffice365 (iOS)	1.29			
	MOffice365 (Windows Phone)	2016			
	MOffice365 (Firefox Browser)	50.1.0			
Mig33	Mig33 (Android)	3.15.255	Communicator	—	StarOS 14.0
	Mig33 (Symbian)	46			
	Mig33 (Windows)	5.0.17			
	Web	—			
MiKandi	MiKandi (Android)	5.2.3	Streaming	Streaming-video Unclassified	ADC Plugin 2.19.895
	MiKandi (iOS)	—			
	MiKandi (Windows)	—			

Protocol / Application	Client	Client Version	Group	Classification	Supported from Release
MLB	MLB (Android)	6.0.1	Streaming	Streaming-video	ADC Plugin 1.148.562
	MLB (iOS)	10.0.1		Unclassified	
Mobcrush	Mobcrush (Android)	17.07.02	Streaming	Streaming-video	ADC Plugin 2.19.895
	Mobcrush (iOS)	17.7.2		Unclassified	
	Mobcrush (Windows)	—			
Mojo	Mojo	—	Peer to Peer File Sharing	—	StarOS 14.0
Monkey3	Monkey3 (Android)	1.17	Streaming	—	1.6
	Monkey3 (iOS)	3_2.2.4			
	Monkey3 (Windows)	5.1.14			
Mozy	Mozy (Android)	1.6.2	Cloud	—	1.9
	Mozy (iOS)	1.6.1			
	Mozy (Web)	—			

Protocol / Application	Client	Client Version	Group	Classification	Supported from Release
MSN	Gaim	—	Communicator	Audio File Transfer Video Unclassified	Pre StarOS 12.0
	Kopete	—			
	Miranda	0.9.1.38			
	MSN (Android)	1.4.0			
	MSN (Blackberry)	10.1.1.16			
	MSN (iOS)	1.2.3			
	MSN (MAC)	4.0.1			
	MSN (MAC)	7.0.2			
	MSN (Windows Mobile)	—			
	MSN (Windows)	16.4.3503			
	Trillian / Trillian Pro	—			
MSRP	—	—	Standard	—	StarOS 14.0
Mute	—	—	Peer to Peer Anonymous File Sharing	—	Pre StarOS 12.0
myCANAL	myCANAL (Android)	3.2.0.1	Streaming	Streaming-video Unclassified	ADC Plugin 2.19.895
	myCANAL (iOS)	2.2.6			
	myCANAL (Windows)	—			
MyPeople	Mypeople (Android)	3.6.1	Communicator	Audio Unclassified	StarOS 12.2
	Mypeople (iOS)	4.4.0			
	Mypeople (Windows)	1.5.72			

Protocol / Application	Client	Client Version	Group	Classification	Supported from Release
MySpace	Myspace	—	Social Network - Generic	—	12.0
	Myspace (Android)	1.8.3			
	Myspace (iOS)	3.5			
	Web	—			
MYTF1	MYTF1 (Android)	6.8.5	Streaming	Streaming-video Unclassified	ADC Plugin 2.19.895
	MYTF1 (iOS)	7.4.2			
	MYTF1 (Windows)	—			
Napster (formerly known as Rhapsody)	Napster (Android)	5.7.3	Streaming	Streaming-audio	1.11
	Napster (iOS)	7.3.0			
	Napster (Windows)	4.0			
NateOn Talk	Nateontalk (Android)	1.2.8	Communicator	—	StarOS 14.0
	Nateontalk (Windows)	3.7			
Nat Geo TV	Nat Geo TV (Android)	1.1.0	Streaming	Streaming-video Unclassified	ADC Plugin 2.2.719
	Nat Geo TV (iOS)	1.1.1			
	Nat Geo TV (Windows)	—			
Naver Line	Line (Android)	5.2.0	Communicator	—	StarOS 14.0
	Line (Blackberry)	1.1.12			
	Line (iOS)	5.1.2			
	Line (Windows)	3.1.9.34			

Protocol / Application	Client	Client Version	Group	Classification	Supported from Release
Navigon	Navigon (Android)	5.2.0	Maps	—	1.9
	Navigon (iOS)	2.7.1			
NBC Sports	NBC Sports (Android)	5.0	Streaming	Streaming-video Unclassified	ADC Plugin 1.149.565
	NBC Sports (iOS)	5.0.2			
NBC TV	NBC TV (Android)	3.1.2.278	Streaming	Streaming-video Unclassified	ADC Plugin 2.0.683
	NBC TV (iOS)	3.1.3.530			
Netflix	Netflix (Android)	5.7.0	Streaming	Ads Streaming-video Unclassified	StarOS 14.0
	Netflix (iOS)	9.41.0			
	Web	—			
	Netflix VR (Android)	1.0.0			ADC Plugin 2.5.771
	Netflix VR (iOS)	—			
	Netflix VR (Windows)	—			
Netmotion	—	—	Internet Privacy	—	StarOS 12.2
Newsy	Newsy (Android)	3.3.1	Streaming	Streaming-video Unclassified	ADC Plugin 1.152.582
	Newsy (iOS)	3.0.1			
Nick	Nick (Android)	2.0.1	Streaming	Streaming-video Unclassified	ADC Plugin 2.14.860
	Nick (iOS)	—			
	Nick (Windows)	—			
Nimbuzz	Nimbuzz (Android)	2.6.4	Communicator	—	StarOS 12.2
	Nimbuzz (iOS)	2.3.0			
	Nimbuzz (Windows)	2.3.1			

Protocol / Application	Client	Client Version	Group	Classification	Supported from Release
Noggin	Noggin (Android)	1.2.1	Streaming	Streaming-video Unclassified	ADC Plugin 2.14.860
	Noggin (iOS)	3.0			
	Noggin (Windows)	—			
Nokia-store	Nokia Ovi Store (Symbian)	3.34.1.18	E-store	—	1.9
NRK TV	NRK TV (Android)	1.7.2	Streaming	Streaming-video Unclassified	ADC Plugin 2.21.912
	NRK TV (iOS)	4.9.8			
	NRK TV (Windows)	—			
Octoshape	—	—	Streaming	—	Pre StarOS 12.0
On Demand Korea (ODK) Media	On Demand Korea (ODK) Media (Android)	1.8.26	Streaming	Streaming-video Unclassified	ADC Plugin 2.28.990
	On Demand Korea (ODK) Media (iOS)	1.4.0.950			
	On Demand Korea (ODK) Media (Windows)	—			

Protocol / Application	Client	Client Version	Group	Classification	Supported from Release
Odnoklassniki	Odnoklassniki (Android)	16.12.22 This version might change with every device.	Streaming	Streaming-audio Streaming-video Unclassified	ADC Plugin 1.155.604
	Odnoklassniki (iOS)	6.9.1			
	OK Live (Android)	1.1.4			
	OK Ru (Android)	17.3.16			
	OK Messages (Android)	1.1.11			ADC Plugin 2.5.771
	OK Live (iOS)	1.2.1			
	OK Ru (iOS)	6.13			
	OK Messages (iOS)	1.2.3			
OFF	—	—	Peer to Peer File Sharing	—	Pre StarOS 12.0
OGG	OGG (Client player)	—	Streaming	—	StarOS 12.2
	OGG (Web player)	—			
Oist	Oist (Android)	1.105	Communicator	—	1.7
	Oist (iOS)	1			
Olx PT	Olx PT(Android)	4.5.9	estore	Unclassified	ADC Plugin 2.29.1008
	Olx PT (iOS)	3.21.0			
	Olx PT (Web)	—			
ooVoo	ooVoo (Android)	2.0.7	Social Network - Video Conference	—	Pre StarOS 12.0
	ooVoo (iOS)	2.0.5			
	ooVoo (Windows)	3.5.9.41			

Protocol / Application	Client	Client Version	Group	Classification	Supported from Release
Opendrive	Opendrive (Android)	2.0.1	Cloud	—	1.9
	Opendrive (iOS)	2.3.1			
	Opendrive (MAC)	1.0.25			
	Opendrive (Web)	—			
	Opendrive (Windows)	1.5.6.4			
OpenFT	—	—	Business	—	Pre StarOS 12.0
OpenVPN	OpenVPN	2.1. 0-3 v1	Internet Privacy	—	StarOS 12.2
Operamini	Operamini (Android)	7.5.2	Browser	—	StarOS 14.0
	Operamini (Blackberry)	6.5			
	Operamini (iOS)	7.0.4			
	Operamini (Symbian)	6.5			
ORB	Orb (Android)	5.3.49	Streaming	—	12.0
	Orb (iOS)	3.11.5			
	Orb (Windows)	5.1.117			

Protocol / Application	Client	Client Version	Group	Classification	Supported from Release
Oscar	AIM (Android)	2.3.4.1	Communicator	Audio File Transfer Video Unclassified	Pre StarOS 12.0
	AIM (iOS)	5.0.4			
	AIM (MAC)	1.5			
	AIM (Windows)	8.0.6019			
	Gaim	—			
	iChat (MAC)	—			
	ICQ (Android)	4.5.1			
	ICQ (iOS)	4.1.3			
	ICQ (Windows)	8.2.6870			
	Kopete	—			
	Miranda	0.9.38			
	Trillian / Trillian Pro	—			
Outlook	Outlook (Android)	2.1.58	E-mail	—	1.6
	Outlook (iOS)	2.4.5			
	Outlook (Windows Phone)	1.2			
Paltalk	Paltalk (Android)	4.9	Communicator	Audio File Transfer Video Unclassified	12.0
	Paltalk (iOS)	4.1.4416			
	Paltalk (Windows)	10.3			
	Paltalk/SuperIM	0.2beta			
Pando	Pando	2.5.11	Peer to Peer File Sharing	—	StarOS 12.2

Protocol / Application	Client	Client Version	Group	Classification	Supported from Release
Pandora	Pandora (Android)	7.9	Streaming	Ads Unclassified	Pre StarOS 12.0
	Pandora (iOS)	7.9			
	Pandora (Windows)	—			
	Pandora (Windows Phone)	1.2.0.0			
Path	Path (Android)	3.4.2	Social Network - Generic	—	1.8
	Path (iOS)	3.4.2			
PBS	PBS (Android)	2.0.4	Streaming	Streaming-video Unclassified	ADC Plugin 2.14.860
	PBS (iOS)	3.2.4			
	PBS (Windows)	—			
	PBS Kids (Android)	2.1.1			
	PBS Kids (iOS)	3.0.4			
	PBS Kids (Windows)	—			
pcAnywhere	pcanyware (Windows)	12.1.0.446	Remote Control	—	StarOS 14.0
Periscope	Periscope (iOS)	1.3	Streaming	—	ADC Plugin 1.146.551
Pinterest	Pinterest (Android)	2.8.5	Social Network - Generic	—	1.2
	Pinterest (iOS)	4.5.1			
	Web	—			
PlayStation	PlayStation (Android)	4.0.5	Streaming	Streaming-video Unclassified	ADC Plugin 2.1.701
	PlayStation (iOS)	2.6.1			
	PlayStation (Windows)	—			

Protocol / Application	Client	Client Version	Group	Classification	Supported from Release
Plingm	Plingm (Android)	1.8.3	Communicator	Audio Unclassified	1.2
	Plingm	2.7.2			
Poco	Poco (Android)	2.0	Social Network - Generic	—	1.4
	Poco (iOS)	1.1.0			
	Poco (Windows)	2.0			
Pokemon-Go	Pokemon-Go (Android)	0.31.0	Gaming	—	ADC Plugin 2.0.683
	Pokemon-Go (iOS)	0.29.3			
PoPo	PoPo	1.1.0911	Communicator	—	Pre StarOS 12.0
PPLive	PPLive (Android)	1.3	Streaming	—	Pre StarOS 12.0
	PPLive (iOS)	1.2			
	PPLive (Windows)	3.2.2.0022			
PPStream	Web	—	Streaming	—	StarOS 12.2
	PPStream (Android)	2.2.2			
	PPStream (iOS)	2.5.0			
	PPStream (Windows)	3.1.0.1166			
PS3	—	—	Gaming	—	Pre StarOS 12.0
Qello Concerts	Qello Concerts (Android)	2.3	Streaming	Streaming-audio Streaming-video Unclassified	ADC Plugin 2.21.912
	Qello Concerts (iOS)	2.6.1			
	Qello Concerts (Windows)	—			

Protocol / Application	Client	Client Version	Group	Classification	Supported from Release
QQ	Pidgin	2.10.1	Communicator	Audio File Transfer Video Unclassified	Pre StarOS 12.0
	QQ	2009			
	QQ (Android)	3.5.1			
	QQ (iOS)	2.2.0			
	QQ (Windows)	1.6			
	Web	—			
QQGame	—	—	Gaming	—	Pre StarOS 12.0
QQLive	Qqlive	—	Streaming	—	Pre StarOS 12.0
	Qqlive (Android)	1.1.1			
	Qqlive (iOS)	1.9.2			
	Qqlive (Web)	—			
	Qqlive (Windows)	8.42			
Quake	—	—	Gaming	—	Pre StarOS 12.0

Protocol / Application	Client	Client Version	Group	Classification	Supported from Release
Quic	—	—	Standard	—	ADC Plugin 1.146.551
	Amazon Video				ADC Plugin 2.9.813
	HBO Now				
	Netflix				
	Vevo				
	ESPN				
	HBO Go				
	FandangoNow				
	Fox Business				
	Fox News				
	FoxNow				
	FxNow				
	Hulu				
	MLB				
	Nat Geo TV				
	NBC Sports				
	NBC TV				
Twitch					
Univision					
QuickTime	QuickTime (Windows)	7.7.5	Streaming	—	StarOS 12.2
Radio Paradise	Radio Paradise (Android)	3.12.3	Streaming	—	1.13
	Radio Paradise (iOS)	6.0.9			
	Radio Paradise (Web)	—			

Protocol / Application	Client	Client Version	Group	Classification	Supported from Release
Radiopup	Radiopup (Android)	3.2.2	Streaming	Streaming-audio Unclassified	ADC Plugin 2.29.1008
	Radiopup(iOS)	3.2.1			
	Radiopup(Web)	—			
RDP	—	—	Remote Control	—	Pre StarOS 12.0
RDT	—	—	Standard	—	StarOS 12.2
Real Media Stream	Real Player (Windows)	16.0.3.513	Streaming	—	Pre StarOS 12.0
Red Bull TV	Red Bull TV (Android)	4.0.0	Streaming	Streaming-video Unclassified	ADC Plugin 2.0.683
	Red Bull TV (iOS)	4.0.3			
	Red Bull Live TV (Android)	4.1.12			ADC Plugin 2.11.833
	Red Bull Live TV (iOS)	4.2.1			
	Red Bull Live TV (Windows)	—			
Reddit	Reddit (Android)	2.22.9	Not applicable	Not applicable	ADC Plugin 2.22.939
	Reddit (iOS)	4.2.0			
	Reddit (Windows)	—			
Regram	Regram (iOS)	1.2	Social Network - Generic	—	1.7
Rfactor	—	—	Gaming	—	Pre StarOS 12.0
Rodi	Rodi (Windows)	0.3.60	P2P File Sharing	—	1.5
Rynga	Rynga (Android)	4.01	Communicator	Audio Unclassified	1.2
	Rynga (iOS)	1			
	Rynga (Windows)	4.13.735			

Protocol / Application	Client	Client Version	Group	Classification	Supported from Release
Samsung-store	Samsung apps (Android)	14040104.21.007	E-store	—	1.9
	Samsung apps (Bada)	1.0.16			
Scydo	Scydo (Android)	5.27	Communicator	—	12.0
	Scydo (iOS)	2.0.6			
Secondlife	—	—	Social Network Gaming	—	Pre StarOS 12.0
Shalom World	Shalom World (Android)	2.0	Streaming	Streaming-video Unclassified	ADC Plugin 2.26.968
	Shalom World (iOS)	5.0			
	Shalom World (Web)	—			
Shoutcast	Winamp (Android)	1.4.10	Streaming	—	Pre StarOS 12.0
	Winamp (Windows)	1.4.5			
Showtime	Showtime (Android)	1.1.1	Streaming	Streaming-video Unclassified	ADC Plugin 1.147.554
	Showtime (iOS)	1.2.1			
Showtime Anytime	Showtime Anytime (Android)	2.6.2	Streaming	Streaming-video Unclassified	ADC Plugin 1.147.554
	Showtime Anytime (iOS)	2.6.4			
Silverlight	Silverlight (Windows)	5.1.20125.0	Streaming	—	1.4

Protocol / Application	Client	Client Version	Group	Classification	Supported from Release
SIP	Ekiga	—	—	—	Pre StarOS 12.0
	Gizmo	—			
	OpenWengo	—			
	SipGate	—			
	Twinkle	—			
	Vonage	—			
	XMeeting	—			
Siri	Siri (iOS)	6.1.3	Internet Privacy	—	1.4
Skinny	—	—	Remote Control	—	Pre StarOS 12.0
Skydrive	Skydrive (Android)	2.6.2	Cloud	—	1.5
	Skydrive (iOS)	3.0.1			
	Skydrive (Windows)	17.0.4041.0512			
	Skydrive (Windows Phone)	3.6.3.0			
	Web	—			

Protocol / Application	Client	Client Version	Group	Classification	Supported from Release
Skype	Bebo	—	Communicator	Audio Video Unclassified	Pre StarOS 12.0 ADC Plugin 2.29.1008
	Buffallo	—			
	eBay	—			
	eBay-Cn	—			
	PCHome	—			
	Skype (Android)	8.30.0.50			
	Skype (Windows)	6.20.0.104			
	Skype (Blackberry)	4.9.507.46973			
	Skype (linux/ubuntu)	5.2			
	Skype (Mac)	6.11			
	Skype (iOS)	8.32			
	Skype (Windows Mobile)	2.21.0.161			
	Skype Mobile (Android)	6.5.0.351			
Slacker Radio	slacker-radio (Android)	6.0.1366	Streaming	Ads Unclassified	1.12
	slacker-radio (Blackberry)	1.0.0.268			
	slacker-radio (iOS)	7.5.5			
	slacker-radio (Windows)	—			
	slacker-radio (Windows Phone)	2.0.15.0			

Protocol / Application	Client	Client Version	Group	Classification	Supported from Release
Slingbox	Slingbox	1.5US	Streaming	—	Pre StarOS 12.0
	Sling box 350/500	—			
	Slingbox M1	—			
	Slingbox Solo	—			
SlingTV	SlingTV (Android)	4.5.2.326	Streaming	—	ADC Plugin 1.143.531
	SlingTV (iOS)	4.1.3			
SmartVoip	Smartvoip (Android)	3.7.1		Audio Unclassified	1.2
	Smartvoip (iOS)	1.08.239			
	Smartvoip (Windows)	4.12			
Smashcast	Smashcast (Android)	1.0.13	Streaming	Streaming-video Unclassified	ADC Plugin 2.28.990
	Smashcast (iOS)	1.0.13			
	Smashcast (Web)	—			
Smule	Smule (Android)	5.1.5	Streaming	Streaming-audio Streaming-video Unclassified	ADC Plugin 2.21.912
	Smule (iOS)	6.2.3			
	Smule (Windows)	—			
Snapchat	Snapchat (Android)	10.38.5.0	Social Network - Generic	—	ADC Pulgin 2.28.990
	Snapchat (iOS)	10.38.0.25			
SoftEther	Softether/ packetix (Windows)	4.0	Internet Privacy	—	1.4
SopCast	Web	—	Streaming	—	Pre StarOS 12.0
	SopCast (Windows)	3.8.3			
Soribada	—	—	Streaming	—	1.1

Protocol / Application	Client	Client Version	Group	Classification	Supported from Release
SoulSeek	NicoTine	1.2.9	Peer to Peer File Sharing	—	Pre StarOS 12.0
	pySoulSeek	—			
	SoulSeek	v157NS 13c			
SoundCloud	SoundCloud (Android)	15.04.10	Streaming	—	1.14
	SoundCloud (iOS)	3.8.0			
	SoundCloud (Windows)	—			
Spark	Spark (Android)	2.0.3499	Streaming	Streaming-video Unclassified	ADC Plugin 2.9.813
	Spark (iOS)	2.3			
	Spark (Windows)	—			
SPDY	—	—	Standard	—	1.2
Speedtest	Speedtest (Android)	4.2.3	Untagged	—	ADC Plugin 2.29.1008
	Speedtest (iOS)	4.0.8			
	Speedtest (Windows)	—			
	Speedtest (Windows Phone)	1.0.0			
Spike	Spike (Android)	1.0.6	Streaming	Streaming-video Unclassified	ADC Plugin 2.11.833
	Spike (iOS)	3.3.0			
	Spike (Windows)	—			
Spinrilla	Spinrilla (Android)	3.9.0	Streaming	Streaming-audio Streaming-video Unclassified	ADC Plugin 2.29.1008
	Spinrilla (iOS)	3.8.3			
	Spinrilla (Web)	—			
SplashFighter	—	—	Gaming	—	Pre StarOS 12.0

Protocol / Application	Client	Client Version	Group	Classification	Supported from Release
Spotify	Spotify (Android)	8.4.79.630	Streaming	—	StarOS 12.2 ADC Plugin 2.29.1008
	Spotify (iOS)	8.4.77			
	Spotify (Windows)	5.2.2.0			
SSDP	—	—	Standard	—	Pre StarOS 12.0
SSL	—	—	Standard	—	ADC Plugin 1.142.526
Starz	Starz (Android)	3.4.1	Streaming	Streaming-video Unclassified	ADC Plugin 1.148.562
	Starz (iOS)	3.4.1			
	MoviePlex (Android)	—			ADC Plugin 2.28.990
	MociePlex (iOS)	—			
	MoviePlex (Web)	—			
StealthNet	—	—	Peer to Peer Anonymous File Sharing	—	Pre StarOS 12.0
Steam	—	—	Gaming	—	Pre StarOS 12.0
Stun	—	—	Standard	—	Pre StarOS 12.0
Sudaphone	Sudaphone (Android)	1.0.6	Communicator	—	1.4
	Sudaphone (iOS)	1.2.2			
SVT play	svtplay (iOS)	2.1.0	Streaming	—	1.4

Protocol / Application	Client	Client Version	Group	Classification	Supported from Release
Tagged	Tagged (Android)	4.0.7	Social-nw-generic	Unclassified	1.10
	Tagged (iOS)	7.1.7			
	Tagged (Windows Phone)	1.0.0.0			
	Tagged (Windows)	—			
Talkatone	Talkatone (Android)	1.1.3	Communicator	Audio Unclassified	1.2
	Talkatone (iOS)	3.0.3			
Tango	Tango (Android)	3.4.7	Communicator	Audio Video Unclassified	StarOS 12.2
	Tango (iOS)	3.3.6			
	Tango (Windows)	8.0.16642			
Taxify	Taxify (Android)	CA.4.4.1	Streaming	Unclassified	ADC Plugin 2.28.990
	Taxify (iOS)	CI.3.54			
	Taxify (Web)	—			
TeamSpeak	TeamSpeak (Windows)	3.0.12	Communicator	—	Pre StarOS 12.0
TeamViewer	TeamViewer (Android)	9.0.1555	Remote Control	—	12.0
	TeamViewer (iOS)	7.0.9			
	TeamViewer (Windows)	9.0.31064			
Telegram	Telegram (Android)	3.0.1	E-mail	Unclassified	1.10
	Telegram (iOS)	3.0			

Protocol / Application	Client	Client Version	Group	Classification	Supported from Release
Tennis Channel Everywhere	Tennis Channel Everywhere (Android)	5.0907	Streaming	Streaming-video Unclassified	ADC Plugin 2.4.739
	Tennis Channel Everywhere (iOS)	4.4			
	Tennis Channel Everywhere (Windows)	—			
Thunder (Xunlei)	Thunder (Windows)	7.9	Peer to Peer File Sharing	—	Pre StarOS 12.0
	kanka (Windows)	7.9			
Tidal	Tidal (Android)	1.11.0.668	Streaming	Streaming-audio Streaming-video Unclassified	ADC Plugin 2.0.683
	Tidal (iOS)	1.14.0			
	Tidal (Windows)	—			
Tinder	Tinder (Android)	6.10.0	—	Instant Messaging Unclassified	ADC Plugin 2.9.813
	Tinder (iOS)	7.3.0			
	Tinder (Windows)	—			
TMO-TV	TMO-TV (Android)	4.5.0.58	Streaming	Streaming-video Unclassified	ADC Plugin 1.148.562
	TMO-TV (iOS)	7.3.53			
Tor	—	—	Anonymous Access	—	StarOS 12.2
Toon Goggles	Toon Goggles (Android)	9.0	Streaming	Streaming-audio Streaming-video Unclassified	ADC Plugin 2.19.895
	Toon Goggles (iOS)	9.1			
	Toon Goggles (Windows)	—			

Protocol / Application	Client	Client Version	Group	Classification	Supported from Release
8tracks	8tracks (Android)	3.3.8	Streaming	Streaming-audio Unclassified	ADC Plugin 1.146.551
	8tracks (iOS)	3.3.47			
TRAI Speedtest	TRAI Speedtest (Android)	6.6.21.19	Streaming	Unclassified	ADC Plugin 2.29.1008
	TRAI Speedtest (iOS)	1.9			
	TRAI Speedtest (Web)	—			
Truecaller	Truecaller (Android)	3.32	Untagged	—	1.4
	Truecaller (Blackberry)	2.9			
	Truecaller (iOS)	3.3.2			
	Truecaller (Symbian)	2.90.0			
	Truecaller (Windows Mobile)	2.90.0			
Truphone	Truphone (Android)	5.4.3	Communicator	—	Pre StarOS 12.0
	Truphone (iOS)	5.4.3			
Tumblr	Tumblr (Android)	3.4.4.0	Social Network - Generic	—	1.5
	Tumblr (iOS)	3.4.3			
	Tumblr (Windows Mobile)	1.0.1.7			
	Photoset (iOS)	1.0.5			
	Web	—			

Protocol / Application	Client	Client Version	Group	Classification	Supported from Release
Tubi TV	Tubi TV (Android)	2.11.4	Streaming	Streaming-video Unclassified	ADC Plugin 2.19.895
	Tubi TV (iOS)	4.0.4			
	Tubi TV (Windows)	—			
TuneIn Radio	TuneIn Radio (Android)	14.4	Streaming	—	ADC Plugin 1.147.554
	TuneIn Radio (iOS)	8.9.2			
Turbo VPN	Turbo VPN (Android)	1.8.1	Internet Privacy	—	ADC Plugin 2.11.833
	Turbo VPN (iOS)	1.8.3			
	Turbo VPN (Windows)	—			
TunnelVoice	—	—	Internet Privacy	—	StarOS 12.2
Tv2Sumo	Tv2Sumo (Android)	2.2.0	Streaming	Streaming-video Unclassified	ADC Plugin 2.23.953
	Tv2Sumo (iOS)	3.0.10			
	Tv2Sumo (Windows)	—			
TV Land	TV Land (Android)	2.1.1	Streaming	Streaming-video Unclassified	ADC Plugin 2.9.813
	TV Land (iOS)	2.6.4			
	TV Land (Windows)	—			
TVAnts	Ants (Windows)	1.6.0	Streaming	—	Pre StarOS 12.0
TVUPlayer	TVUPlayer (Windows)	2.5.3.1	Streaming	—	Pre StarOS 12.0

Protocol / Application	Client	Client Version	Group	Classification	Supported from Release
Twitch	Twitch (Android)	4.10.2	Gaming	—	1.11
	Twitch (iOS)	3.10.1			
	Twitch (Windows)	—			
Twitter	Twitter (Android)	7.11.0	Social Network - Generic	Streaming-video Unclassified	12.0
	Twitter (Blackberry)	10.2.1.2			
	Twitter (iOS)	7.6			
	Twitter (Web)	—			
Uber	Uber (Android)	3.134.8	Standard	—	ADC Plugin 2.4.739
	Uber (iOS)	3.225.3			
	Uber (Windows)	4.0.4.0			
UFC	UFC (Android)	3.3	Streaming	Streaming-video Unclassified	ADC Plugin 2.22.939
	UFC (iOS)	8.0126			
	UFC (Windows)	—			
UltraBac	UltraBac (Windows)	9.2.4	File Sharing	—	StarOS 12.2
UltraSurf	Ultrasurf (Windows)	13.01	Internet Privacy	—	1.4
	Ultrasurf (Android)	1.0.6			ADC Plugin 2.11.833
Univision	Univision Deportes (Android)	10.2.0	Streaming	Streaming-video Unclassified	ADC Plugin 1.149.565
	Univision Deportes (iOS)	5.4			
	Univision NOW (Android)	7.0309			
	Univision NOW (iOS)	2.6			

Protocol / Application	Client	Client Version	Group	Classification	Supported from Release
UPC Phone	upc-phone (Android)	2.0.1	Communicator	Audio Unclassified	1.12
	upc-phone (iOS)	1.0.1			
Usenet	Usenet (Windows)	5.78	Standard	—	StarOS 12.2
Ustream	Ustream (Android)	3.0.2	Streaming	—	1.4
	Ustream (iOS)	3.2.2			
	Web	—			
UUSee	UUSee (iOS)	5.9.303.3	Streaming	—	Pre StarOS 12.0
VCast	—	—		—	Pre StarOS 12.0
VChat	VChat (MAC)	1.1	Social Network - Video Conference	—	1.7
VeohTV	—	—	Streaming	—	Pre StarOS 12.0
Vessel	Vessel (Android)	1.0.706	Streaming	Streaming-video Unclassified	ADC Plugin 1.143.531
	Vessel (iOS)	2.3.0			
Vevo	Vevo (Android)	2.2.17	Streaming	Streaming-video Unclassified	ADC Plugin 1.148.562
	Vevo (iOS)	5.0.4			
Viber	Viber (Android)	9.6.5.5	Communicator	Audio Instant Messaging Unclassified	Pre StarOS 12.0 ADC Plugin 2.29.1008
	Viber (iOS)	9.6.5			
Vine	Vine (Android)	5.36.0	Social Network - Generic	—	1.6
	Vine (iOS)	5.37.0			
	Vine (Windows)	2.5.6.2			

Protocol / Application	Client	Client Version	Group	Classification	Supported from Release
Vimeo	Vimeo (Android)	3.0.1	Streaming	Streaming-video Unclassified	ADC Plugin 2.28.990
	Vimeo (iOS)	6.30			
	Vimeo (Web)	—			
	IndieFlix (Android)	—			
	IndieFlix (iOS)	—			
	IndieFlix (Web)	—			
	Tribeca Shortlist (Android)	—			
	Tribeca Shortlist (iOS)	—			
	Tribeca Shortlist (Web)	—			
Vkontakte	Vkontakte (Android)	5.19	Streaming	Streaming-audio Streaming-video Unclassified	ADC Plugin 2.29.1008
	Vkontakte (iOS)	5.0.1			
	Vkontakte (Web)	—			
VoipDiscount	VoipDiscount	4.14	Communicator	Audio Unclassified	1.2
Vopium	—	—	Communicator	Audio Unclassified	1.2
Voxer	Voxer (Android)	1.2.1.001	Communicator	Audio Unclassified Video	1.5
	Voxer (iOS)	2.7.0			
	Voxer (Windows Mobile)	0.9.2.0			
Viki	Viki (Android)	4.14.4	Streaming	Streaming-video Unclassified	ADC Plugin 2.23.953
	Viki (iOS)	5.1.0			
	Viki (Windows)	—			

Protocol / Application	Client	Client Version	Group	Classification	Supported from Release
VPN Master	VPN Master (Android)	6.0.2	Internet Privacy	—	ADC Plugin 2.11.833
	VPN Master (iOS)	2.5.2			
	VPN Master (Windows)	—			
VPN-X	—	—	Internet Privacy	—	Pre StarOS 12.0
Vtok	Vtok (Android)	1.0.1	Communicator	—	1.5
	Vtok (iOS)	3.0.1			
VTun	—	—	Internet Privacy	—	Pre StarOS 12.0
Vudu	Vudu (Android)	1.2.1	Streaming	—	ADC Plugin 1.144.540
	Vudu (iOS)	1.2			
Warcraft3	—	—	Gaming	—	Pre StarOS 12.0
Waze	Waze (Android)	3.7.8	Untagged	—	1.8
	Waze (iOS)	3.7.8			
	Waze (Windows Phone)	3.7.4.5			
Webex	Webex (Android)	9.9.0	Business	—	StarOS 14.0
	Webex (iOS)	9.9.0			
	Webex (Windows7)	7.2.0			
Wechat	Wechat (Android)	6.5.13	Communicator	—	1.1
	Wechat (iOS)	6.5.17			

Protocol / Application	Client	Client Version	Group	Classification	Supported from Release
Weibo	Weibo (Android)	4.3.5	Social Network - Generic	—	1.9
	Weibo (Blackberry)	1.1.0.6			
	Weibo (iOS)	4.3.0			
	Weibo (Windows)	3.0.5.35670			
	Weibo (Windows Phone)	3.3.0			
WhatsApp	WhatsApp (Android)	2.18.380	Communicator	Audio Video Unclassified	2.31.XXXX
	WhatsApp (Blackberry)	2.10.8002			
	WhatsApp (iOS)	2.19.11			
	WhatsApp (Web)	—			
	WhatsApp (Windows Mobile)	1.7.0.0			
WII	—	—	Gaming	—	Pre StarOS 12.0
Willow TV	Willow TV (Android)	5.4	Streaming	Streaming-video Unclassified	ADC Plugin 2.26.968
	Willow TV (iOS)	3.10			
	Willow TV (Web)	—			
Windows-azure	Windows-azure (Web)	—	Cloud	—	1.9
Windows-store	Windows Store (Windows Phone)	8.0	E-store	—	1.9
Windows Media Stream (WMStream)	—	—	Streaming	—	Pre StarOS 12.0

Protocol / Application	Client	Client Version	Group	Classification	Supported from Release
WinMX	—	—	Peer to Peer File Sharing	—	Pre StarOS 12.0
Winny	Winny	2.0.b6.6	Peer to Peer Anonymous File Sharing	—	Pre StarOS 12.0
World of Kungfu	—	—	Gaming	—	Pre StarOS 12.0
World of Warcraft	—	—	Gaming	—	Pre StarOS 12.0
Wuala	—	—	Cloud	—	1.1
WWE	WWE (Android)	3.9.039001418	Streaming	Streaming-video	ADC Plugin 1.157.618
	WWE (iOS)	3.10.0		Unclassified	
Xbox	—	—	Gaming	—	Pre StarOS 12.0
XDCC	XDCC Catcher	—	Peer to Peer File Sharing	—	Pre StarOS 12.0
	XDCC Fetcher	—			
	XDCC Klipper	—			
Xfinity TV	Xfinity TV (Android)	3.9.0.036	Streaming	Streaming-video Unclassified	ADC Plugin 2.2.719
	Xfinity TV (iOS)	3.0.1.664			
	Xfinity TV (Windows)	—			
Xing	Xing (Android)	4.1.1.610	Social-nw-generic	Unclassified	1.10
	Xing (iOS)	4.9.3			
	Xing (Windows Phone)	5.2.0.0			
	Xing (Windows)	—			
Yahoo	Gaim	—	Communicator	Audio	Pre StarOS 12.0
	Kopete	—		File Transfer	
	Miranda	—		Video Unclassified	

Protocol / Application	Client	Client Version	Group	Classification	Supported from Release
	Trillion	Trillion			
	Yahoo (Windows)	11.5.0.228			
	Yahoo (Android)	6.4.1			
	Yahoo (iOS)	6.4.0			
	Yahoo (MAC)	3.0.2			
Yahoo Mail	Yahoomail (Android)	5.1.0	E-mail	—	1.6
	Yahoomail (iOS)	4.0.3			
	Yahoomail (Web)	—			
YipTV	YipTV (Android)	5.1.0	Streaming	Streaming-video Unclassified	ADC Plugin 2.9.813
	YipTV (iOS)	5.1			
	YipTV (Windows)	—			
Yoga Free VPN	Yoga Free VPN (Android)	3.1.006	Internet Privacy	—	ADC Plugin 2.11.833
	Yoga Free VPN (iOS)	—			
	Yoga Free VPN (Windows)	—			
Youku	Youku (Android)	3.7	Streaming	—	1.8
	Youku (iOS)	3.3			
	Youku (Windows Phone)	3.1			
	Youku (Web)	—			
Your Freedom Tunnel	Your Freedom Tunnel	20111213-13	Anonymous Access	—	12.0

Protocol / Application	Client	Client Version	Group	Classification	Supported from Release
YouTube	Youtube (Android)	13.50.52	Streaming	Ads File Transfer Streaming-video Unclassified	1.5
	Youtube (iOS)	14.03			
	Youtube (Windows Mobile)	49.0.2623.110			
	Youtube (Web)	—			
	Great Big Story (Android)	—			ADC Plugin 2.31.XXXX
	Great Big Story (iOS)	—			
	Great Big Story (Web)	—			
Zattoo	—	—	Streaming	—	Pre StarOS 12.0
Zello	Zello (Android)	3.99	Communicator	—	ADC Plugin 2.23.953
	Zello (iOS)	3.53			
	Zello (Windows)	—			

Port-based Protocols

This section lists the port-based protocols currently supported by Cisco ADC. These are TCP and UDP protocols that are classified according to their well-known ports. The default TCP and UDP ports of each of the protocols are listed. As part of IP Protocol and Transport Port Mapping, a static mapping of transport port to strings is provided in EDRs.

Protocol Name	TCP Ports	UDP Ports
3COM-AMP3	629	629
3COM-TSMUX	106	106
914C/G	211	211
9PFS	564	564
ACAP	674	674
ACAS	62	62
ACCESSBUILDER	888	888

Protocol Name	TCP Ports	UDP Ports
ACCESSNETWORK	699	699
ACI	187	187
ACMAINT_DBD	—	774
ACMAINT_TRANSD	—	775
ACP	599	599
ACR-NEMA	104	104
AED-512	149	149
AGENTX	705	705
AIM	5190–5193	—
ALPES	463	463
AMINET	2639	2639
ANARCHY	7013, 7500–7501	7013, 7500–7501
ANET	212	212
ANSANOTIFY	116	116
ANSATRADER	124	124
AODV	654	654
APERTUS-LDP	539	539
\QTC	458	458
APPLEQTCSRVR	545	545
APPLIX	—	999
ARCISDMS	262	262
ARIEL1	419	419
ARIEL2	421	421
ARIEL3	422	422
ARNS	384	384
ASA	386	386
ASA-APPL-PROTO	502	502
ASHERONS CALL	9000–9013	9000–9013

Protocol Name	TCP Ports	UDP Ports
ASIA	626	626
ASIPREGISTRY	687	687
ASIP-WEBADMIN	311	311
AS-SERVERMAP	449	449
AT-3	203	203
AT-5	205	205
AT-7	207	207
AT-8	208	208
AT-ECHO	204	204
AT-NBP	202	202
AT-RTMP	201	201
AT-ZIS	206	206
AUDIONEWS	114	114
AUDIT	182	182
AUDITD	48	48
AURORA-CMGR	364	364
AURP	387	387
AUTH	113	113
AUX_BUS_SHUNT	623	623
AVIAN	486	486
AYIYA IPv6 Tunneled	5072	5072
BANYAN-RPC	567	567
BANYAN-VIP	573	573
BDP	581	581
BFTP	152	152
BGMP	264	264
BGP	179	179
BGS-NSI	482	482

Protocol Name	TCP Ports	UDP Ports
BH611	354	354
BHEVENT	357	357
BHFHS	248	248
BHMDS	310	310
BIFF	—	512
BLACK AND WHITE	2611–2612	—
BL-IDM	142	142
BMPP	632	632
BNET	415	415
BOOTPC	68	68
BOOTPS	67	67
BORLAND-DSJ	707	707
BUSBOY	998	998
CABLEPORT-AX	282	282
CAB-PROTOCOL	595	595
CADLOCK	770	770
CAILIC	216	216
CAL	588	588
CALL OF DUTY	28960	20500, 20510, 28960
CDC	223	223
CFDPTKT	120	120
CHARGEN	19	19
CHSHELL	562	562
CIMPLEX	673	673
CISCO-FNA	130	130
CISCO-SYS	132	132
CISCO-TDP	711	711
CISCO-TNA	131	131

Protocol Name	TCP Ports	UDP Ports
CITADEL	504	504
CL/1	172	172
CLEARCASE	371	371
CLOANTO-NET-1	356	356
CMIP-AGENT	164	164
CMIP-MAN	163	163
COAUTHOR	1529	1529
CODAAUTH2	370	370
COLLABORATOR	622	622
COMMERCE	542	542
COMPRESSNET	2, 3	2, 3
COMSCM	437	437
CON	759	759
CONCERT	786	786
CONFERENCE	531	531
CONNENDP	693	693
CONTENTSERVER	454, 3365	454, 3365
CORBA-IIOP	683	683
CORBA-IIOP-SSL	684	684
CORERJD	284	284
COUNTER STRIKE	27020–27039	1200, 27000–27014
COURIER	530	530
COVIA	64	64
CREATIVEPARTNR	455, 3366	455, 3366
CREATIVESERVER	453, 3364	453, 3364
CRS	507	507
CRYPTOADMIN	624	624
CSI-SGWP	348	348

Protocol Name	TCP Ports	UDP Ports
CSNET-NS	105	105
CTF	84	84
CUSTIX	528	528
CVC_HOSTD	442	442
CYBERCASH	551	551
CYCLESERV	763	763
CYCLESERV2	772	772
DANTZ	497	497
DARK REIGN	26214	26214
DASP	439	439
DATASURFSRV	461	461
DATASURFSRVSEC	462	462
DATEX-ASN	355	355
DAYTIME	13	13
DBASE	217	217
DCP	93	93
DCTP	675	675
DDM-DFM	447	447
DDM-RDB	446	446
DEC_DLM	625	625
DECAP	403	403
DECAUTH	316	316
DECBSRV	579	579
DECLADEBUG	410	410
DECVMS-SYSMGT	441	441
DEI-ICDA	618	618
DELTA FORCE	3100, 3999	3100, 3999, 3568, 3569
DEOS	76	76

Protocol Name	TCP Ports	UDP Ports
DEVICE	801	801
DEVICESHARE	552	552
DHCP-FAILOVER	647	647
DHCP-FAILOVER2	847	847
DHCPv6-CLIENT	546	546
DHCPv6-SERVER	547	547
DIABLO	6113–6119	6113–6119
DIGITAL-EVM	619	619
DIGITAL-VRC	466	466
DIRECT	242	242
DIRECTPLAY	2234	2234
DIRECTPLAY8	6073	6073
DIRECTV-CATLG	3337	3337
DIRECTV-SOFT	3335	3335
DIRECTV-TICK	3336	3336
DIRECTV-WEB	3334	3334
DISCARD	9	9
DISCLOSE	667	667
DIXIE	96	96
DLS	197	197
DLS-MON	198	198
DN6-NLM-AUD	195	195
DN6-SMM-RED	196	196
DNA-CML	436	436
DNSIX	90	90
DOOM	666	666
DPSI	315	315
DSETOS	378	378

Protocol Name	TCP Ports	UDP Ports
DSFGW	438	438
DSP	33	33
DSP3270	246	246
DTAG-STE-SB	352	352
DTK	365	365
DWR	644	644
ECHO	7	7
EFS	520	—
ELCSD	704	704
ELITE FORCE	—	26000, 27500
EMBL-NDT	394	394
EMFIS-CNTL	141	141
EMFIS-DATA	140	140
ENTOMB	775	—
ENTRUST-AAAS	680	680
ENTRUST-AAMS	681	681
ENTRUST-ASH	710	710
ENTRUST-KMSH	709	709
ENTRUST-SPS	640	640
ENTRUSTTIME	309	309
ERPC	121	121
ESCP-IP	621	621
ESRO-EMSDP	642	642
ESRO-GEN	259	259
EUDORA-SET	592	592
EXCHANGE	135	—
EXEC	512	—
EYELINK	589	589

Protocol Name	TCP Ports	UDP Ports
F16	—	3862, 3863
F22 SIMULATOR (LIGHTNING 3)	—	3874–3875, 4533, 4534
FATSERV	347	347
FCP	510	510
FINGER	79	79
FLEXLM	744	744
FLN-SPX	221	221
FSGS	6112	6112
FTP-AGENT	574	574
FTP-DATA	20	20
FTPS-DATA	989	989
FUJITSU-DEV	747	747
FXP-1	286	286
GACP	190	190
GAME-SEARCH	29001	—
GAME-SPY	6500, 28900, 29000	6515, 27900
GARCON	999	—
GDOMAP	538	538
GENIE	402	402
GENRAD-MUX	176	176
GGF-NCP	678	678
GINAD	634	634
GLT POLIANE	1201	—
GO-LOGIN	491	491
GOPHER	70	70
GPPITNP	103	103
GRAPHICS	41	41

Protocol Name	TCP Ports	UDP Ports
GROOVE	2492	2492
GSS-HTTP	488	488
GSS-XLICEN	128	128
GTP-USER	2152	2152
HA-CLUSTER	694	694
HALFLIFE	—	7002, 27015, 27025
HAP	661	661
HASSLE	375	375
HCP-WISMAR	686	686
HDAP	263	263
HELLO-PORT	652	652
HEMS	151	151
HERETIC II	28910	28910
HEXEN	26900	26900
HMMP-IND	612	612
HMMP-OP	613	613
HOSTNAME	101	101
HOSTS2-NS	81	81
HP-ALARM-MGR	383	383
HP-COLLECTOR	381	381
HP-MANAGED-NODE	382	382
HTTP-ALT	591	591
HTTP-MGMT	280	280
HTTP-RPC-EPMAP	593	593
HYBRID-POP	473	473
HYPER-G	418	418
HYPERWAVE-ISP	692	692
IAFDBASE	480	480

Protocol Name	TCP Ports	UDP Ports
IAFSERVER	479	479
IASD	432	432
IBM-APP	385	385
IBM-DB2	523	523
IBPROTOCOL	6714	6714
ICAD-EL	425	425
ICLCNET_SVINFO	887	887
ICLCNET-LOCATE	886	886
IDEAFARM-CATCH	903	903
IDEAFARM-CHAT	902	902
IDFP	549	549
IEEE-MMS	651	651
IEEE-MMS-SSL	695	695
IIOF	535	535
IMAP3	220	220
IMAPS	993	993
IMSP	406	406
INBUSINESS	244	244
INFOSEEK	414	414
INGRES-NET	134	134
INTECOURIER	495	495
INTEGRA-SME	484	484
INTRINSA	503	503
IPCD	576	576
IPCSEVER	600	600
IPDD	578	578
IPP	631	631
IPX	213	213

Protocol Name	TCP Ports	UDP Ports
IRCS	994	994
IRC-SERV	529	529
IS99C	379	379
IS99S	380	380
ISI-GL	55	55
ISIS	2042	2042
ISO-ILL	499	499
ISO-IP	147	147
ISO-TP0	146	146
ISO-TSAP	102	102
ISO-TSAP-C2	399	399
ITM-MCELL-S	828	828
JARGON	148	148
KALI	2213	2213
K-BLOCK	287	287
KERBEROS	88	88
KERBEROS-ADM	749	749
KEYSERVER	584	584
KINGPIN	31510	31510
KIS	186	186
KLOGIN	543	543
KNET-CMP	157	157
KOHAN IMMORTAL SOVEREIGNS	3855, 17437	3855, 17437
KONSPIRE2B	6085	6085
KPASSWD	464	464
KRYPTOLAN	398	398
KSHELL	544	544

Protocol Name	TCP Ports	UDP Ports
LA-MAINT	51	51
LANSERVER	637	637
LDAP	389	389
LDAPS	636	636
LDP	646	646
LEGENT-1	373	373
LEGENT-2	374	374
LINK	245	245
LJK-LOGIN	472	472
LOCKD	4045	4045
LOCUS-CON	127	127
LOCUS-MAP	125	125
LOGIN	513	—
MAC-SRVR-ADMIN	660	660
MAGENTA-LOGIC	313	313
MAILBOX-LM	505	505
MAILQ	174	174
MAITRD	997	997
MANET	269	269
MASQDIALER	224	224
MATIP-TYPE-A	350	350
MATIP-TYPE-B	351	351
MCIDAS	112	112
MCNS-SEC	638	638
MDBS_DAEMON	800	800
MDC-PORTMAPPER	685	685
MECOMM	668	668
MEREGISTER	669	669

Protocol Name	TCP Ports	UDP Ports
META5	393	393
METAGRAM	99	99
METER	570, 571	570, 571
MFCOBOL	86	86
MFTP	5402	5402
MICOM-PFS	490	490
MICROMUSE-LM	1534	1534
MICROSOFT-DS	445	445
MIT-DOV	91	91
MIT-ML-DEV	83	83
MM-ADMIN	534	534
MMS	1755	—
MOBILEIP-AGENT	434	434
MOBILIP-MN	435	435
MONDEX	471	471
MONITOR	561	561
MORTGAGEWARE	367	367
MOTORHEAD	16000, 16010–16030	16000, 16010–16030
MPEG	3155	3155
MPM	45	45
MPM-FLAGS	44	44
MPM-SND	46	46
MPP	218	218
MPTN	397	397
MRM	679	679
MSDP	639	639
MSEXCH-ROUTING	691	691
MSFT-GC	3268	3268

Protocol Name	TCP Ports	UDP Ports
MSFT-GC-SSL	3269	3269
MSG-AUTH	31	31
MSG-ICP	29	29
MSNP	1863	1863
MS-OLAP	2393, 2394, 2382, 2384	2393, 2394, 2382, 2384
MSP	18	18
MS-ROME	569	569
MS-SHUTTLE	568	568
MS-SQL-M	1434	1434
MS-SQL-S	1433	1433
MULTILING-HTTP	777	777
MULTIPLEX	171	171
MUMPS	188	188
MYLEX-MAPD	467	467
MYTH	3453	3453
NAME	42	42
NAMP	167	167
NAS	991	991
NCED	404	404
NCLD	405	405
NCP	524	524
NDSAUTH	353	353
NEED FOR SPEED	9442	9442
NEED FOR SPEED 3	1030	1030
NEST-PROTOCOL	489	489
NET8-CMAN	1830	1830
NET-ASSISTANT	3283	3283
NETBIOS	137, 138, 139	137, 138, 139

Protocol Name	TCP Ports	UDP Ports
NETGW	741	741
NETNEWS	532	532
NETRCS	742	742
NETRJS-1	71	71
NETRJS-2	72	72
NETRJS-3	73	73
NETRJS-4	74	74
NETSC-DEV	155	155
NETSC-PROD	154	154
NETVIEWDM1	729	729
NETVIEWDM2	730	730
NETVIEWDM3	731	731
NETWALL	533	533
NETWARE-IP	396	396
NEWACCT	100	—
NEW-RWHO	550	550
NEXTSTEP	178	178
NFS	2049	2049
NICNAME	43	43
NI-FTP	47	47
NI-MAIL	61	61
NIP	376	376
NLOGIN	758	758
NMAP	689	689
NMSP	537	537
NNSP	433	433
NNTP	119	119
NNTPS	563	563

Protocol Name	TCP Ports	UDP Ports
NOTES (LOTUS NOTES)	1352	1352
NOTIFY	3016	3016
NOVADIGM	3460–3465	3460–3465
NOVASTORBAKCUP	308	308
NPMP-GUI	611	611
NPMP-LOCAL	610	610
NPMP-TRAP	609	609
NPP	92	92
NQS	607	607
NS	760	760
NSIIOPS	261	261
NSRMP	359	359
NSS-ROUTING	159	159
NSW-FE	27	27
NTALK	518	518
NXEDIT	126	126
OBEX	650	650
OBJCALL	94	94
OCBINDER	183	183
OCS_AMU	429	429
OCS_CMU	428	428
OCSERVER	184	184
ODMR	366	366
OHIMSRV	506	506
OLSR	698	698
OMGINITIALREFS	900	900
OMSERV	764	764
ONMUX	417	417

Protocol Name	TCP Ports	UDP Ports
OPALIS-RDV	536	536
OPALIS-ROBOT	314	314
OPC-JOB-START	423	423
OPC-JOB-TRACK	424	424
OPENPORT	260	260
OPENVMS-SYSIPC	557	557
OPERATION FLASH POINT	47624	—
ORACLENAMES	1575	1575
ORACLENET8CMAN	1630	1630
ORA-SRV	1525	1525
ORBIX-CONFIG	3076	3076
ORBIXD	1570	1570
ORBIX-LOCATOR	3075	3075
ORBIX-LOC-SSL	3077	3077
OSU-NMS	192	192
OUTLAWS	5310	5310
PARSEC-GAME	6582	6582
PASSGO	511	511
PASSGO-TIVOLI	627	627
PASSWORD-CHG	586	586
PAWSERV	345	345
PCANYWHERE	5631, 5632	5631, 5632
PCMAIL-SRV	158	158
PDAP	344	344
PERSONAL-LINK	281	281
PFTP	662	662
PH	481	481
PHILIPS-VC	583	583

Protocol Name	TCP Ports	UDP Ports
PHONEBOOK	767	767
PHOTURIS	468	468
PIM-RP-DISC	496	496
PIP	321	321
PIRP	553	553
PKIX-3-CA-RA	829	829
PKIX-TIMESTAMP	318	318
POP2	109	109
POV-RAY	494	494
POWERBURST	485	485
PRINTER	515	515
PRINT-SRV	170	170
PRM-NM	409	409
PRM-SM	408	408
PROFILE	136	136
PROSPERO	191	191
PS2	10070–10080	10070
PS3	5223	3478, 3479, 3658
PSSC	645	645
PTCNAMESERVICE	597	597
PTP-EVENT	319	319
PTP-GENERAL	320	320
PUMP	751	751
PURENOISE	663	663
PWDGEN	129	129
QBIKGDP	368	368
QFT	189	189
QMQP	628	628

Protocol Name	TCP Ports	UDP Ports
QMTP	209	209
QOTD	17	17
QRH	752	752
QSC	—	787
QUOTAD	762	762
RADMIN	4899, 6222	4899, 6222
RAINBOX SIX	7777, 8777, 9777	7777, 8777, 9777
RAP	256	256
RCP	469	469
RDA	1571	—
REALM-RUSD	688	688
RE-MAIL-CK	50	50
REMOTE DESKTOP	3389	—
REMOTEFSS	556	556
REMOTE-KIS	185	185
REPCMD	641	641
REPCMD	653	653
RESCAP	283	283
RFILE	750	750
RIPNG	521	521
RIS	180	180
RIS-CM	748	748
RJE	5	5
RLP	39	39
RLZDBASE	635	635
RMC	657	657
RMIACTIVATION	1098	1098
RMIREGISTRY	1099	1099

Protocol Name	TCP Ports	UDP Ports
RMONITOR	560	560
RMT	411	411
ROUTER	—	520
RPASSWD	774	—
RPC2PORTMAP	369	369
RRH	753	753
RRP	648	648
RSH-SPX	222	222
RSVD	168	168
RSVP_TUNNEL	363	363
RSYNC	873	873
RTELNET	107	107
RTIP	771	771
RTMP	1935	1935
RTSPS	322	322
RUNESCAPE	43594–43595	—
RUSHD	696	696
RXE	761	761
SAFT	487	487
SANITY	643	643
SCC-SECURITY	582	582
SCO-DTMGR	617	617
SCOHELP	457	457
SCOI2ODIALOG	360	360
SCO-INETMGR	615	615
SCO-SYSMGR	616	616
SCO-WEBSRVRMG3	598	598
SCO-WEBSRVRMGR	620	620

Protocol Name	TCP Ports	UDP Ports
SCX-PROXY	470	470
SDNSKMP	558	558
SECURE-AUX-BUS	664	664
SECURE-FTP	990	990
SECURE-POP3	995	995
SECURE-TELNET	992	992
SEMANTIX	361	361
SEND	169	169
SEP	2089	2089
SERVSTAT	633	633
SET	257	257
SFS-CONFIG	452	452
SFS-SMP-NET	451	451
SFTP	115	115
SGCP	440	440
SGMP	153	153
SGMP-TRAPS	160	160
SHELL	514	—
SHOCKWAVE	1626	1626
SHRINKWRAP	358	358
SIAM	498	498
SIFT-UFT	608	608
SILC	706	706
SILVERPLATTER	416	416
SIN	22450	22450
SIP	5060–5061	5060–5061
SITARADIR	2631	2631
SITARAMGMT	2630	2630

Protocol Name	TCP Ports	UDP Ports
SITARASERVER	2629	2629
SKRONK	460	460
SMAKYNET	122	122
SMARTSDP	426	426
SMPNAMERES	901	901
SMPTE	420	420
SMSD	596	596
SMSP	413	413
SMUX	199	199
SNAGAS	108	108
SNARE	509	—
S-NET	166	166
SNMP	161	161
SNMPTRAP	162	162
SNTP-HEARTBEAT	580	580
SOCKS	1080	1080
SOFTPC	215	215
SOLDIER OF FORTUNE	—	28911–28915
SONAR	572	572
SPMP	656	656
SPSC	478	478
SQLEXEC	9088	9088
SQLNET	1521	—
SQL-NET	66, 150	66, 150
SQLSERV	118	118
SQLSRV	156	156
SRC	200	200
SRMP	193	193

Protocol Name	TCP Ports	UDP Ports
SRSEND	362	362
SS7NS	477	477
SSH	22	22
SSHELL	614	614
SST	266	266
STARSIEGE	—	29001–29009
STARWARS JEDI KNIGHT	—	28060–28062, 28070–28081
STATSRV	133	133
STMF	501	501
STREAMWORK	1558	1558
STREETALK	566	566
STX	527	527
SUBMISSION	587	587
SUBMIT	773	—
SUBNTBCST_TFTP	247	247
SU-MIT-TG	89	89
SUN-DR	665	665
SUNRPC	111	111
SUPDUP	95	95
SURF	1010	1010
SUR-MEAS	243	243
SVRLOC	427	427
SWAT3	16639	16638
SWIFT-RVF	97	97
SYNOPTICS-TRAP	412	412
SYNOTICS-BROKER	392	392
SYNOTICS-RELAY	391	391
SYSLOG	—	514

Protocol Name	TCP Ports	UDP Ports
SYSTAT	11	11
TACACS	49	49
TACACS-DS	65	65
TACNEWS	98	98
TALK	517	517
TD-REPLICA	268	268
TD-SERVICE	267	267
TEEDTAP	559	559
TELL	754	754
TELNET	23	23
TEMPO	526	526
TENFOLD	658	658
TEREDO	—	3544
TEXAR	333	333
TICF-1	492	492
TICF-2	493	493
TIMBUKTU	407	407
TIME	37	37
TIMED	525	525
TINC	655	655
TLISRV	1527	1527
TNETOS	377	377
TNS-CML	590	590
TN-TL-FD1	476	476
TN-TL-W1	474	—
TN-TL-W2	—	474
TPIP	594	594
TRIBES	28001	28001

Protocol Name	TCP Ports	UDP Ports
TSERVER	450	450
UAAC	145	145
UARPS	219	219
UIS	390	390
ULISTPROC	372	372
ULP	522	522
ULPNET	483	483
ULTIMA	1737	1737
UMA	1797	1797
UNIDATA-LDM	388	388
UNIFY	181	181
UNREAL_UT	7778	7778-7783
UPS	401	401
URL-RENDEZVOUS	659	659
URM	606	606
UTIME	519	519
UTMPCD	431	431
UTMPSD	430	430
UUCP	540	540
UUCP-PATH	117	117
UUCP-RLOGIN	541	541
UUIDGEN	697	697
VACDSM-APP	671	671
VACDSM-SWS	670	670
VATP	690	690
VEMMI	575	575
VID	769	769
VIDEOTEX	516	516

Protocol Name	TCP Ports	UDP Ports
VMNET	175	175
VMPWSCS	214	214
VNAS	577	577
VNC	5900, 5901, 5902	—
VPP	677	677
VPPS-QUA	672	676
VSINET	996	996
VSLMP	312	312
WAP-PUSH	2948	2948
WAP-PUSH-HTTP	4035	4035
WAP-PUSH-HTTPS	4036	4036
WAP-PUSHSECURE	2949	2949
WAP-VCAL	9205	9205
WAP-VCAL-S	9207	9207
WAP-VCARD	9204	9204
WAP-VCARD-S	9206	9206
WAP-WSP-S	9202	9202
WAP-WSP-WTP	9201	9201
WAP-WSP-WTP-S	9203	—
WARCRAFT	3724	3724
WEBSTER	765	765
WESTWOOD ONLINE	1140, 1234, 4000	1140, 1234, 4000
WHO	—	513
WHOAMI	565	565
WHOIS	63	63
WOLFENSTEIN ENEMY TERRITORY	27952, 27960, 27965	27950, 27951, 27952, 27960, 27965
WORK-SOL	400	400

Protocol Name	TCP Ports	UDP Ports
WORLDUFUSION	2595–2596	2595–2596
WPAGES	776	776
WPGS	780	780
WTA-WSP-S	2805	2805
XACT-BACKUP	911	911
X-BONE-CTL	265	265
XBOX LIVE	3074	3074
XDMCP	177	177
XDTP	3088	3088
XFER	82	82
XFR	682	682
XNS-AUTH	56	56
XNS-CH	54	54
XNS-COURIER	165	165
XNS-MAIL	58	58
XNS-TIME	52	52
XVTPP	508	508
XWINDOWS	6000–6063	6000–6063
XYPLEX-MUX	173	173
YAHOO GAMES	11999	11999
YAK-CHAT	258	258
Z39.50	210	210
ZANNET	317	317
ZNES	—	7845
ZSERV	346	346

IP Protocols

This chapter lists the IP protocols supported by Cisco ADC. These are protocols (such as ICMP), other than TCP and UDP protocols that are identified according to the IP protocol number of the transaction. For each protocol, the protocol index number in the IP header is provided. As part of IP Protocol and Transport Port Mapping, a static mapping of IP protocol to strings is provided in EDRs.

IP Protocol Number	Protocol Name
0	HOPOPT
1	ICMP
2	IGMP
3	GGP
4	IP-v4
5	ST
6	TCP
7	CBT
8	EGP
9	IGP
10	BBN-RCC-MON
11	NVP-II
12	PUP
13	ARGUS
14	EMCON
15	XNET
16	CHAOS
17	UDP
18	MUX
19	DCN-MEAS
20	HMP
21	PRM
22	XNS-IDP
23	TRUNK-1

IP Protocol Number	Protocol Name
24	TRUNK-2
25	LEAF-1
26	LEAF-2
27	RDP
28	IRTP
29	ISO-TP4
30	NETBLT
31	MFE-NSP
32	MERIT-INP
33	DCCP
34	3PC
35	IDPR
36	XTP
37	DDP
38	IDPR-CMTP
39	TP++
40	IL
41	IPv6
42	SDRP
43	IPv6-Route
44	IPv6-Frag
45	IDRP
46	RSVP
47	GRE
48	DSR
49	BNA
50	ESP
51	AH

IP Protocol Number	Protocol Name
52	I-NLSP
53	SWIPE
54	NARP
54	NHRP
55	MOBILE
56	TLSP
57	SKIP
58	IPv6-ICMP
59	IPv6-NoNxt
60	IPv6-Opts
62	CFTP
64	SAT-EXPAK
65	KRYPTOLAN
66	RVD
67	IPPC
69	SAT-MON
70	VISA
71	IPCV
72	CPNX
73	CPHB
74	WSN
75	PVP
76	BR-SAT-MON
77	SUN-ND
78	WB-MON
79	WB-EXPAK
80	ISO-IP
81	VMTP

IP Protocol Number	Protocol Name
82	SECURE-VMTP
83	VINES
84	TTP
85	NSFNET-IGP
86	DGP
87	TCF
88	EIGRP
89	OSPFIGP
90	Sprite-RPC
91	LARP
92	MTP
93	AX.25
94	IPIP
95	MICP
96	SCC-SP
97	ETHERIP
98	ENCAP
100	GMTP
101	IFMP
102	PNNI
103	PIM
104	ARIS
105	SCPS
106	QNX
107	A/N
108	IPComp
109	SNP
110	Compaq-Peer

IP Protocol Number	Protocol Name
111	IPX-in-IP
112	VRRP
113	PGM
115	L2TP
116	DDX
117	IATP
118	STP
119	SRP
120	UTI
121	SMP
122	SM
123	PTP
124	ISIS-over-IPv4
125	FIRE
126	CRTP
127	CRUDP
128	SSCOMPCE
129	IPLT
130	SPS
131	PIPE
132	SCTP
133	FC
134	RSVP-E2E-IGNORE
135	Mobility-Header
136	UDPLITE
137	MPLS-in-IP
138	manet
139	HIP

IP Protocol Number	Protocol Name
140	Shim6
141	WESP
142	ROHC



CHAPTER 5

Reporting SSL Parameters in EDR

This chapter describes the following topics:

- [Feature Summary and Revision History, on page 139](#)
- [Feature Description, on page 140](#)
- [How It Works, on page 140](#)
- [Configuring SSL Parameters in EDR, on page 142](#)
- [Monitoring and Troubleshooting, on page 142](#)

Feature Summary and Revision History

Summary Data

Applicable Product(s) or Functional Area	All Products supporting ADC
Applicable Platform(s)	<ul style="list-style-type: none">• ASR 5500• VPC-DI• VPC-SI
Feature Default	Enabled - Always-on
Related Changes in This Release	Not Applicable
Related Documentation	<i>ADC Administration Guide</i>

Revision History

Revision Details	Release
First introduced.	21.5

Feature Description

The ADC (P2P) engine detects encrypted traffic using Server Name Indication (SNI)/ Canonical Name (CNAME) field (signatures) of SSL flow in Client and Server Hello packets. To mark the flow as SSL, both Client and Hello packets must be parsed without any error. There could be several error conditions due to which ADC SSL decoder could fail, such as failure to receive Server Hello, invalid Type Value Length (TLV), invalid header length, absence of a certificate, and so on. When any of these error conditions are seen, the flow is marked as "p2p-unknown" instead of SSL although the packets are exchanged on TCP Port 443. As a result, the flow is matched to the "ip any-match" rule instead of an SSL rule.

With this feature, these failure reasons are reported in EDR for better debugging purposes and to know why a flow is not marked as SSL. Subsequently, marking a flow as an application traffic based on SNI has a limitation of users spoofing the SNI field to gain advantage of the various service provider monetary plans. SSL makes use of certificates to authenticate the endpoints. As such, to overcome SNI spoofing, ADC parses the various information in the SSL Server Hello packet and reports the same in EDR for debugging.

How It Works

This section provides a brief overview of how this feature works.

- ADC stores the reason for SSL decode failure.
- ADC stores the validity of SSL certificate.
 - Has the certificate expired (> not-after).
 - Is the certificate still valid (between not-before and not-after).
 - Can the certificate be used (< not-before).

Currently, ADC decodes 'not-after' and 'not-before' and stores them internally. As part of this feature, the 'not-after' and 'not-before' is parsed with current system time and report values 0, 1, 2 in EDR.

- Support is added to configure the required SSL certificate parameters in EDR.
- Support is added to report the certificate information in charging EDR.
- Support is added to generate charging EDR for that flow and report the parsed information.
- Boxer is compatible with a plugin with and without changes.
- If the value of attributes; SSL ISSUER CNAME, SSL ISSUER ORG or SSL SUBJECT ORG contains “,”; the Boxer converts the same to “_” before printing in EDR.

EDR

The SSL parameters issued from plugin can be configured as EDR fields. The particular values corresponding to different EDR fields is populated, if present in the flow.

Following SSL parameters are identified to be reported in EDR:

- **SSL decode failure:** A flow can fail to be detected as SSL due to one of the following reasons:

1. IPOQUE_SSL_CLIENT_HELLO_DECODE_SUCCESS,
2. IPOQUE_SSL_SERVER_HELLO_DECODE_SUCCESS,
3. IPOQUE_SSL_CLIENT_HELLO_INVALID_EXT_LEN,
4. IPOQUE_SSL_SERVER_HELLO_INVALID_EXT_LEN,
5. IPOQUE_SSL_SERVER_HELLO_NO_CERTIFICATE,
6. IPOQUE_SSL_SERVER_HELLO_INVALID_SNO_LEN,
7. IPOQUE_SSL_SERVER_HELLO_INVALID_SIGNATURE_LEN,
8. IPOQUE_SSL_SERVER_HELLO_ISSUER_NOT_FOUND,
9. IPOQUE_SSL_SERVER_HELLO_INVALID_VALIDITY,
10. IPOQUE_SSL_SERVER_HELLO_INVALID_VALIDITY_NOT_BEFORE,
11. IPOQUE_SSL_SERVER_HELLO_INVALID_VALIDITY_NOT_AFTER,
12. IPOQUE_SSL_SERVER_HELLO_INVALID_SUBJECT_LEN

EDR will contain a value of 1-12 corresponding to above reasons in the same order with IPOQUE_SSL_CLIENT_HELLO_DECODE_SUCCESS being 1 and IPOQUE_SSL_SERVER_HELLO_INVALID_SUBJECT_LEN being 12.

Following are the conditions when above failure reasons will be reported:

- Client Hello Success – Client Hello decoded successfully but further packets are not received in flow (absence of Server Hello).
- Server Hello Success – SSL flow decoded successfully without any issues, both Client and Server Hello packets.
- Invalid Client/Server Hello Extension Length – When length of any of the TLVs in Client/Server Hello is 0 (zero) or more than packet length respectively.
- Server Hello No certificate – Absence of any certificates in Server Hello.
- Server Hello Invalid Subject/SNO/Signature Len – When length of Subject/Serial Number/Signature TLVs in Server Hello is 0 (zero) or more than packet length respectively.
- Server Hello Issuer Not Found – Absence of Issuer certificate in Server Hello.
- Server Hello Invalid Validity/Validity Not Before/Validity Not After – Absence of these fields in Server Hello.
- Subject Organization Name – Name of the Organization/Company to which the SSL certificate is issued.
- Issuer CNAME – Canonical Name of the Organization/Company issuing the certificate
- Issuer Organization Name – Name of the Organization/Company issuing the SSL certificate
- SSL Certificate Validity:
 - EDR value of 1 – Current date is less than Certificate not before date
 - EDR value of 2 – Current date is greater than Certificate not after date

- EDR value of 3 – Current date is within Certificate not before and not after dates

Issuer provides a certificate subjected for a particular duration of time, after which the same must be renewed or the certificate is deemed invalid. This field states whether the certificate exchanged in Server Hello is currently valid or expired.

Configuring SSL Parameters in EDR

This section provides information on CLI commands available in support of this feature.

Enabling SSL Parameters

Use the following configuration to enable SSL Parameters under EDR Format Configuration Mode:

```
active-charging service service_name
  edr-format format_name
    rule-variable p2p ssl-params { cert-issuer-cname | cert-subject-oname
  | cert-issuer-oname | cert-validity | ssl-decode-failure } priority
priority
end
```

NOTES:

- **ssl-params**: Specifies the SSL flow parameters.
- **cert-issuer-cname**: Specifies the SSL Certificate Issuer CName.
- **cert-subject-oname**: Specifies the SSL Certificate Subject Organization Name.
- **cert-issuer-oname**: Specifies the SSL Certificate Issuer Organization Name.
- **cert-validity**: Specifies the validity of SSL Certificate.
- **ssl-decode-failure**: Specifies the reason for SSL Decode failure.

Monitoring and Troubleshooting

This section provides information about show CLI commands and/or their outputs in support of this feature.

Show Commands and/or Outputs

show active-charging edr-format all

The output of this CLI command has been enhanced to display the new SSL parameters. Following is a sample output:

```
show active-charging edr-format all
Service Name: service_1
Edr Format Name: edr_1
rule-variable p2p ssl-params cert-subject-oname priority 1
```

show configuration active-charging service all

The output of this CLI command has been enhanced to display the new SSL parameters. Following is a sample output:

```
show configuration active-charging service all
config
  active-charging service service_1
    no ng-ecs-enabled
    edr-format edr_1
      rule-variable p2p ssl-params cert-subject-oname priority 1
    exit
  rulebase default
    no tcp check-window-size
  exit
  policy-control burst-size auto-readjust duration 5
  exit
end
```



CHAPTER 6

Support for SNI Detection

This chapter describes the Server Name Indication (SNI) Detection feature in ADC, and provides detailed information on the following topics:

- [Feature Description, on page 145](#)
- [Configuring SNI Detection, on page 147](#)
- [Monitoring and Troubleshooting the SNI Detection, on page 149](#)

Feature Description

Server Name Indication (SNI) is an extension of the Transport Layer Security (TLS) protocol that allows multiple secure (HTTPS) websites (or any other service over TLS) to be served from the same IP address without requiring all those sites to use the same certificate. SNI provides a mechanism for the client to tell the server which hostname it is trying to connect to.

ADC detects encrypted traffic using the SNI field (signatures) of TLS/SSL (Secure Sockets Layer) traffic. These signatures are added along with other detection mechanisms and delivered as a plugin. If there are new SNI fields either in the already detected applications or new applications, then these new fields are added to the plugin and a new version of the plugin is released. This results in frequent releases of plugin versions causing delay in upgrading the new plugin in the network and leading to revenue leak to the operator. Due to increased number of applications moving towards TLS/SSL, an option is provided to configure the SNI in ruledef and classify traffic based on the configured SNI with this release.



Important

The SNI Detection feature requires a valid Application Detection and Control license. Contact your Cisco Account representative for more information.

The SNI field in the TLS/SSL handshake is used to determine the type of TLS/SSL flow being setup. SNI rule variable is added as an optional field in EDRs for detection of TLS/SSL flows. When the “tls sni” rule variable is configured and a valid SNI name is detected in the flow, the SNI field is populated in the EDR.

QUIC SNI Detection

The SNI Detection feature is enhanced to support QUIC SNI configuration and classify traffic based on the configured SNI. The CLI commands added to configure the SNI are generic such that other application-identifiers added in the future are taken care of with the Plugin changes only.

**Important**

This feature requires the latest ADC Plugin to be loaded from the `adc_v2.x` stream along with StarOS changes. The default plugin does not support this feature. Contact your Cisco account representative for more information.

When a QUIC flow is analyzed, the P2P rule match takes place on this flow with the configured SNI. If the flow/packet matches the rule, the custom-defined-protocol (CDP) name specified in the ruledef is taken and the flow is marked as CDP. If no CDP is configured in the rule, then the flow is treated as QUIC flow.

Within the P2P plugin, when a QUIC flow arrives with SNI that is already hardcoded and the same SNI is also configured in ruledef, the ruledef with higher priority takes precedence. Based on rule priority, rule matching is done and CDP statistics get incremented. When the new QUIC flow comes with SNI that is not hardcoded, the flow will be marked as a QUIC flow.

- The **p2p app-identifier** and **p2p set-app-proto** commands are added in the ACS Ruledef Configuration mode to configure QUIC-SNI and TLS-SNI that are dynamically populated from the P2P plugin and match the traffic against it.
- EDR attributes are added to support app-identifiers supplied from plugin. EDR logs the matched CDP in the "p2p-protocol" field for the flow. If QUIC-SNI is configured in the EDR field, then QUIC-SNI string will be populated.
- Analyzer statistics, ruledef statistics, and bulk statistics are updated for newly identified protocols
- Backward compatibility for the TLS-SNI feature is maintained such that this feature works seamlessly with new CLI commands added in this release.

Limitations

The limitations with this feature are listed in this section:

- The **quic-sni** identifier is configured in the EDR with the new plugin. When rolled back to old plugins, the EDR headers will print **p2p-unknown** since the old plugin does not support the configured app-identifier. When upgraded to a new plugin that supports QUIC-SNI identifier, **p2p-unknown** will be updated to display **p2p-quic-sni** in the EDR.
- The help strings related to the new CLI keywords will be updated in a later release.

Relationships to Other Features

This section describes how the SNI Detection feature relates to other ADC features.

- **Analyzer Interworking:** In support of SNI Detection, HTTPS protocol support is added for ECS analysis of all SSL flows as part of the Analyzer Interworking feature. This feature is enabled by default for all analyzers including HTTPS if P2P detection/protocol is enabled.

The different behaviors when Analyzer Interworking is enabled or disabled is listed in the table below.

Condition	HTTPS Routing Enabled	HTTPS Routing Disabled
With SNI feature in 17.5 and later releases:		

Condition	HTTPS Routing Enabled	HTTPS Routing Disabled
If SSL protocol is enabled, SNI/EDR features will work if any routing rule is configured	<ul style="list-style-type: none"> Analyzer Interworking enabled for HTTPS: App-proto = HTTPS(6) and p2p protocol = SSL Analyzer Interworking disabled for HTTPS: App-proto = P2P(29) and p2p protocol = SSL 	App-proto = P2P(29) and p2p protocol = SSL
If SSL protocol is disabled, SNI/EDR features will not work.	App-proto = HTTPS(6) and p2p protocol = Unknown	App-proto = Unknown(0) and p2p protocol = Unknown
Without SNI feature in releases prior to 17.5:		
SNI/EDR features will not work and SSL will not be exposed to ASR 5500.	App-proto = HTTPS(6) and p2p protocol = Unknown	App-proto = Unknown(0) and p2p protocol = Unknown

- **SSL Renegotiation Tracking:** With the SNI Detection feature, the ADC plugin must be able to store Session ID in SSL renegotiated table, map the renegotiated flow to stored Session ID, and map the corresponding CDP name to the flow in the same way as it is done for SSL Renegotiation feature.

For more information on these features, refer to the *ADC Administration Guide*.

Configuring SNI Detection

This section describes how to configure the SNI Detection feature.

Configuring SNI in Ruledef

Use the following configuration to configure the TLS/SSL and QUIC Server Name Indication (SNI) and the corresponding custom defined protocol (CDP).



Important

The QUIC SNI Detection feature requires the latest ADC Plugin to be loaded from the `adc_v2.x` stream along with StarOS changes. The default plugin does not support this feature. Contact your Cisco account representative for more information.

```

configure
  active-charging service service_name
    ruledef ruledef_name
      [ no ] tls { set-app-proto cdp_name_string | sni operator server_name_string
      }
      [ no ] p2p app-identifier { quic-sni operator quic_sni_string | tls-cname
operator tls_cname_string | tls-sni operator tls_sni_string }

```

```
[ no ] p2p set-app-PROTO cdp_name_string
end
```

Notes:

- The **tls set-app-PROTO** command specifies the name of the custom defined protocol for TLS/SSL flows matching the ruledef.
- The **tls sni** command specifies the TLS/SSL Server Name Indication (SNI) field value in the Client Hello packet.
- In release 20.2, the **p2p app-identifier** command configures "quic-sni", "tls-sni", and "tls-cname" app-identifiers supported by the P2P dynamic library.
- In release 20.2, the **p2p set-app-PROTO** command configures the custom-defined protocol (CDP) name.
- The following commands must be configured for SNI rules to work:

- Enable SSL protocol in the Active Charging Service configuration:

```
[local]P2P_SS1(config-acs)# p2p-detection protocol ssl
```

If the **p2p-detection protocol all** CLI command is enabled in the Active Charging Service configuration, then the **ssl** keyword need not be enabled again as it will be already enabled with the **all** keyword.

The **ssl** protocol is available only in Plugin releases 1.142.526 and later.

- Enable P2P in the ACS Rulebase configuration:

```
[local]P2P_SS1(config-rule-base)# p2p dynamic-flow-detection
```

- The action priority for SNI ruledef must be configured in the rulebase similar to other ruledefs.

For more information, refer to the *ACS Ruledef Configuration Mode* chapter of the *Command Line Interface Reference*.

Configuring SNI rule variable

Use the following configuration to configure the SNI rule variable for TLS/SSL and QUIC flows in EDR.

```
configure
  active-charging service acs_service_name
    edr-format format_name
      rule-variable tls sni priority priority
      rule-variable p2p app-identifier { quic-sni | tls-cname | tls-sni
    } priority priority
  end
```

Notes:

- The **tls sni** command specifies the TLS/SSL SNI rule variable configured for TLS/SSL flows in EDR.
- In release 20.2, the **p2p app-identifier** command specifies the QUIC-SNI, TLS-SNI, and TLS-CNAME application identifiers populated from the plugin.
- **priority priority**: Specifies the CSV position of the field (protocol rule) in the EDR. *priority* must be an integer from 1 through 65535.

For more information, refer to the *EDR Format Configuration Mode* chapter of the *Command Line Interface Reference*.

Enabling HTTPS Analyzer Interworking

Use the following configuration to enable or disable ECS analysis for HTTPS analyzer interworking.

```
configure
  active-charging service service_name
    [ no ] p2p-detection ecs-analysis { https }
  end
```

Notes:

- The Active Charging flows will have the app-proto marked as "HTTPS" instead of P2P for all SSL flows if analyzer interworking for HTTPS is enabled.
- The Active Charging flows will have the app-proto marked as "P2P" for all SSL flows if analyzer interworking for HTTPS is disabled.
- By default, analyzer interworking for all analyzers including HTTPS is enabled when P2P detection is enabled.

For more information on the commands listed above, refer to the *Command Line Interface Reference*.

Verifying the SNI Configuration

Executing the following command displays the application/protocol configured in the "set app-proto" string of TLS ruledef:

```
show active-charging analyzer statistics name cdp [ application app_name | instance instance_number |
summary | verbose | wide ]
```

Executing the following command displays the fields for TLS/SSL SNI and CDP as configured in the TLS ruledef:

```
show active-charging ruledef name ruledef_name
```

Monitoring and Troubleshooting the SNI Detection

This section provides information on the show commands available to support this feature.

SNI Detection Show Command(s) and/or Outputs

show active-charging analyzer statistics name cdp

The following fields display the analyzer statistics for the custom defined protocol.

- CDP Summary:
 - Total Uplink Bytes
 - Total Downlink Bytes

- Total Uplink Pkts
- Total Downlink Pkts

For description of the fields listed above see, *Statistics and Counters Reference*.

show active-charging flows type cdp

The following fields display the flow-level statistics for the custom defined protocol.

- Session ID
- Flow-ID
- Application Protocol
- Transport Protocol
- Tethered Flow
- Bytes-Up
- Bytes-Down
- Pkts-Up
- Pkts-Down

Bulk Statistics

In support of the SNI detection feature, the "p2p-protocol" field in the P2P schema will display the application protocol configured in the "set app-proto" string of TLS ruledef.

For more information on bulk statistics, see the *P2P Schema Statistics* chapter in the *Statistics and Counters Reference*.