



PDSN Administration Guide, StarOS Release 21.17

First Published: 2019-12-19

Last Modified: 2021-10-11

Americas Headquarters

Cisco Systems, Inc.
170 West Tasman Drive
San Jose, CA 95134-1706
USA
<http://www.cisco.com>
Tel: 408 526-4000
800 553-NETS (6387)
Fax: 408 527-0883

THE SPECIFICATIONS AND INFORMATION REGARDING THE PRODUCTS IN THIS MANUAL ARE SUBJECT TO CHANGE WITHOUT NOTICE. ALL STATEMENTS, INFORMATION, AND RECOMMENDATIONS IN THIS MANUAL ARE BELIEVED TO BE ACCURATE BUT ARE PRESENTED WITHOUT WARRANTY OF ANY KIND, EXPRESS OR IMPLIED. USERS MUST TAKE FULL RESPONSIBILITY FOR THEIR APPLICATION OF ANY PRODUCTS.

THE SOFTWARE LICENSE AND LIMITED WARRANTY FOR THE ACCOMPANYING PRODUCT ARE SET FORTH IN THE INFORMATION PACKET THAT SHIPPED WITH THE PRODUCT AND ARE INCORPORATED HEREIN BY THIS REFERENCE. IF YOU ARE UNABLE TO LOCATE THE SOFTWARE LICENSE OR LIMITED WARRANTY, CONTACT YOUR CISCO REPRESENTATIVE FOR A COPY.

The Cisco implementation of TCP header compression is an adaptation of a program developed by the University of California, Berkeley (UCB) as part of UCB's public domain version of the UNIX operating system. All rights reserved. Copyright © 1981, Regents of the University of California.

NOTWITHSTANDING ANY OTHER WARRANTY HEREIN, ALL DOCUMENT FILES AND SOFTWARE OF THESE SUPPLIERS ARE PROVIDED "AS IS" WITH ALL FAULTS. CISCO AND THE ABOVE-NAMED SUPPLIERS DISCLAIM ALL WARRANTIES, EXPRESSED OR IMPLIED, INCLUDING, WITHOUT LIMITATION, THOSE OF MERCHANTABILITY, FITNESS FOR A PARTICULAR PURPOSE AND NON-INFRINGEMENT OR ARISING FROM A COURSE OF DEALING, USAGE, OR TRADE PRACTICE.

IN NO EVENT SHALL CISCO OR ITS SUPPLIERS BE LIABLE FOR ANY INDIRECT, SPECIAL, CONSEQUENTIAL, OR INCIDENTAL DAMAGES, INCLUDING, WITHOUT LIMITATION, LOST PROFITS OR LOSS OR DAMAGE TO DATA ARISING OUT OF THE USE OR INABILITY TO USE THIS MANUAL, EVEN IF CISCO OR ITS SUPPLIERS HAVE BEEN ADVISED OF THE POSSIBILITY OF SUCH DAMAGES.

Any Internet Protocol (IP) addresses and phone numbers used in this document are not intended to be actual addresses and phone numbers. Any examples, command display output, network topology diagrams, and other figures included in the document are shown for illustrative purposes only. Any use of actual IP addresses or phone numbers in illustrative content is unintentional and coincidental.

All printed copies and duplicate soft copies of this document are considered uncontrolled. See the current online version for the latest version.

Cisco has more than 200 offices worldwide. Addresses and phone numbers are listed on the Cisco website at www.cisco.com/go/offices.

Cisco and the Cisco logo are trademarks or registered trademarks of Cisco and/or its affiliates in the U.S. and other countries. To view a list of Cisco trademarks, go to this URL: <https://www.cisco.com/c/en/us/about/legal/trademarks.html>. Third-party trademarks mentioned are the property of their respective owners. The use of the word partner does not imply a partnership relationship between Cisco and any other company. (1721R)

© 2019-2021 Cisco Systems, Inc. All rights reserved.



CONTENTS

PREFACE

About this Guide	xxi
Conventions Used	xxi
Supported Documents and Resources	xxiii
Related Common Documentation	xxiii
Related Product Documentation	xxiii
Obtaining Documentation	xxiii
Contacting Customer Support	xxiv

CHAPTER 1

CDMA2000 Wireless Data Services	1
Product Description	1
Qualified Platforms	2
Features and Functionality—Base Software	2
Gx and Gy Support	2
RADIUS Support	3
Access Control List Support	4
IP Policy Forwarding	5
AAA Server Groups	6
Overlapping IP Address Pool Support	6
Routing Protocol Support	6
Management System Overview	8
Bulk Statistics Support	9
Threshold Crossing Alerts (TCA) Support	10
IP Header Compression - Van Jacobson	10
DSCP Marking	11
Features and Functionality - Optional Enhanced Software Features	11
Session Recovery Support	12

- IPv6 Support 12
- L2TP LAC Support 13
- L2TP LNS Support 14
- Proxy Mobile IP 14
- IP Security (IPSec) 15
- Traffic Policing and Rate Limiting 15
 - Intelligent Traffic Control 16
- Dynamic RADIUS Extensions (Change of Authorization) 17
- Features and Functionality - Inline Service Support 18
 - Content Filtering 18
 - Integrated Adult Content Filter 18
 - ICAP Interface 19
 - Network Address Translation (NAT) 19
 - Peer-to-Peer Detection 20
 - Personal Stateful Firewall 20
- Features and Functionality - External Application Support 21
 - Mobility Unified Reporting 21
- CDMA2000 Data Network Deployment Configurations 21
 - Standalone PDSN/FA and HA Deployments 22
 - Interface Descriptions 22
 - Co-Located Deployments 23
- Understanding Simple IP and Mobile IP 24
 - Simple IP 25
 - How Simple IP Works 25
 - Mobile IP 28
 - Mobile IP Tunneling Methods 28
 - How Mobile IP Works 31
 - Proxy Mobile IP 35
 - How Proxy Mobile IP Works 35
- Supported Standards 41
 - Requests for Comments (RFCs) 41
 - TIA and Other Standards 44
 - Telecommunications Industry Association (TIA) Standards 44
 - Object Management Group (OMG) Standards 45

3GPP2 Standards 45

IEEE Standards 46

CHAPTER 2

Understanding the Service Operation and Configuration 47

Terminology 47

Contexts 47

AAA Realms 48

Ports 49

Logical Interfaces 49

Bindings 50

Services 50

AAA Servers 52

Subscribers 52

 Default Subscribers and Realm-based Subscriber Templates 53

How the System Selects Contexts 55

 Context Selection for Context-level Administrative User Sessions 55

 Context Selection for Subscriber Sessions 57

 AAA Context Selection for Subscriber Sessions 57

 Destination Context Selection For Subscriber Sessions 60

CHAPTER 3

Simple IP Configuration Examples 63

Example 1: Simple IP Support Using a Single Source and Destination Context 63

Information Required 64

 Source Context Configuration 64

 Destination Context Configuration 70

How This Configuration Works 72

Example 2: Simple IP Using a Single Source Context and Multiple Outsourced Destination Contexts

73

Information Required 74

 Source Context Configuration 74

 Destination Context Configuration 80

 System-Level AAA Configuration 84

How This Configuration Works 86

CHAPTER 4	Mobile IP Configuration Examples	91
	Example 1: Mobile IP Support Using the System as a PDSN/FA	91
	Information Required	92
	Source Context Configuration	92
	AAA Context Configuration	95
	Mobile IP Destination Context Configuration	98
	System-Level AAA Configuration	101
	Optional Destination Context	103
	How This Configuration Works	105
	Example 2: Mobile IP Support Using the System as an HA	106
	Information Required	107
	Source Context Configuration	107
	Destination Context Configuration	113
	How This Configuration Works	114
	Example 3: HA Using a Single Source Context and Multiple Outsourced Destination Contexts	116
	Information Required	117
	Source Context Configuration	117
	Destination Context Configuration	124
	System-Level AAA Configuration	127
	How This Configuration Works	129
CHAPTER 5	Simple IP and Mobile IP in a Single System Configuration Example	133
	Using the System as Both a PDSN/FA and an HA	133
	Information Required	134
	Source Context Configuration	134
	AAA Context Configuration	137
	Mobile IP Destination Context Configuration	139
	Simple IP Destination Context	147
	System-Level AAA Parameter Configuration	148
	How This Configuration Works	149
CHAPTER 6	Service Configuration Procedures	153
	Configuring PDSN Closed R-P Services	153

	Verifying your Configuration	154
	Creating and Configuring PDSN Services	155
	Verifying the PDSN Services	156
	Creating and Configuring FA Services	157
	Verifying the FA Service	158
	Creating and Configuring HA Services	160
	Verifying the HA Service	161
	Configuring IP Address Pools on the System	162
	Creating IPv4 Pool	162
	Creating IPv6 Pool	163
	Adding Overlap-Pool Addresses to Routing	163
	Verifying IP Pool Configuration	163
<hr/>		
CHAPTER 7	Monitoring the Service	165
	Monitoring System Status and Performance	165
	Clearing Statistics and Counters	169
<hr/>		
CHAPTER 8	Troubleshooting the System	171
	Test Commands	171
	Using the PPP Echo-Test Command	171
<hr/>		
APPENDIX A	Engineering Rules	173
	Interface and Port Rules	173
	R-P Interface Rules	173
	Closed R-P Interface Rules	174
	Pi Interface Rules	174
	FA to HA Rules	174
	HA to FA	175
	Subscriber Rules	175
	Service Rules	175
<hr/>		
APPENDIX B	Supported Registration Reply Codes	177
	PDSN Service Reply Codes	177
	FA Service Reply Codes	178

APPENDIX C	Mobile-IP and Proxy-MIP Timer Considerations 183
	Call Flow Summary 183
	Dealing with the 'Requested Lifetime Too Long' Error Code 185
	Controlling the Mobile IP Lifetime on a Per-Domain Basis 185

APPENDIX D	Always-on 189
	Overview 189
	Configuring Always-on 190
	Configuring Always-on 190
	Verifying Your Configuration 191

APPENDIX E	Broadcast Multicast Service 193
	Overview 193
	Licensing 194
	Configuring BCMCS 194
	BCMCS Group Configuration 194
	RADIUS Server Configuration 194

APPENDIX F	CoA, RADIUS DM, and Session Redirection (Hotlining) 197
	RADIUS Change of Authorization and Disconnect Message 197
	CoA Overview 197
	DM Overview 198
	License Requirements 198
	Enabling CoA and DM 198
	Enabling CoA and DM 198
	CoA and DM Attributes 199
	CoA and DM Error-Cause Attribute 200
	Viewing CoA and DM Statistics 201
	Session Redirection (Hotlining) 202
	Overview 202
	License Requirements 202
	Operation 202
	ACL Rule 202

Redirecting Subscriber Sessions	203
Session Limits On Redirection	203
Stopping Redirection	203
Handling IP Fragments	203
Recovery	203
AAA Accounting	204
Viewing the Redirected Session Entries for a Subscriber	204

APPENDIX G
Gx Interface Support 207

Rel. 7 Gx Interface	207
Introduction	208
Supported Networks and Platforms	210
License Requirements	210
Supported Standards	210
Terminology and Definitions	210
Policy Control	211
Charging Control	215
Policy and Charging Control (PCC) Rules	216
PCC Procedures over Gx Reference Point	218
Volume Reporting Over Gx	220
How Rel. 7 Gx Works	225
Configuring Rel. 7 Gx Interface	229
Configuring IMS Authorization Service at Context Level	230
Applying IMS Authorization Service to an APN	232
Configuring Volume Reporting over Gx	233
Gathering Statistics	234
Rel. 8 Gx Interface	234
HA/PDSN Rel. 8 Gx Interface Support	235
Introduction	235
Terminology and Definitions	237
How it Works	245
Configuring HA/PDSN Rel. 8 Gx Interface Support	248
Gathering Statistics	251
P-GW Rel. 8 Gx Interface Support	252

- Introduction 252
- Terminology and Definitions 252
- Rel. 9 Gx Interface 257
 - P-GW Rel. 9 Gx Interface Support 257
 - Introduction 257
 - Terminology and Definitions 258
 - 3GPP Rel.9 Compliance for IPFilterRule 263
- Rel. 10 Gx Interface 265
 - P-GW Rel. 10 Gx Interface Support 266
 - Introduction 266
 - Terminology and Definitions 266
- Supported Gx Features 274
 - Assume Positive for Gx 274
 - Default Policy on CCR-I Failure 275
 - Gx Back off Functionality 276
 - Support for Volume Reporting in Local Policy 276
 - Support for Session Recovery and Session Synchronization 277
 - Configuring Gx Assume Positive Feature 277
 - Time Reporting Over Gx 279
 - License Requirements 279
 - Feature Overview 279
 - Usage Monitoring 280
 - Usage Reporting 281
 - Configuring Time Reporting over Gx 282
 - Support for Multiple Active and Standby Gx Interfaces to PCRF 283
 - Configuring Diameter Peer Selection at Diabase in Failure Scenarios 283
 - Support for Multiple CCR-Us over Gx Interface 284
 - Configuring Gateway Node to Support Back-to-Back CCR-Us 285
 - Support for RAN/NAS Cause IE on Gx Interface 285
 - Configuring Supported Feature Netloc-RAN-NAS-Cause 285
 - Support ADC Rules over Gx Interface 286
 - Limitations 287
 - Configuring ADC Rules over Gx 287
 - GoR Name Support in TDF-Application-Identifier 287

ADC Mute Customization	288
Support for TAI and ECGI Change Reporting	291
Feature Description	291
How it Works	292
Monitoring and Troubleshooting the TAI and ECGI Change Reporting Feature	293
Location Based Local-Policy Rule Enforcement	294
Feature Description	294
How it Works	295
Configuring Location Based Local Policy Rule Enforcement Feature	296
Monitoring and Troubleshooting the Location Based LP Rule Enforcement Feature	298
Gx Support for GTP based S2a/S2b	299
Gx-based Virtual APN Selection	299
Feature Description	299
Configuring Gx based Virtual APN Selection Feature	300
Monitoring and Troubleshooting the Gx based Virtual APN Selection	300
Graceful Handling of RAR from Different Peers	301
NetLoc Feature Enhancement	302
Feature Description	302
Command Changes	306
Performance Indicator Changes	307
RAN-NAS Cause Code Feature Enhancement	307
Feature Description	307
Command Changes	311
Session Disconnect During Diamproxy-Session ID Mismatch	311
Feature Description	311
Configuring System to Delete Diamproxy-Session ID Mismatched Sessions	312
Monitoring and Troubleshooting the Mismatched Session Deletion Feature	313
Support for Negotiating Mission Critical QCIs	313
Feature Description	314
Configuring DPCA for Negotiating Mission Critical QCIs	314
Monitoring and Troubleshooting the Mission Critical QCI	315
HSS and PCRF-based P-CSCF Restoration Support for WLAN	315
Feature Description	316
Configuring the HSS/PCRF-based P-CSCF Restoration	317

- Monitoring and Troubleshooting the HSS/PCRF-based P-CSCF Restoration 318
- Loop Prevention for Dynamic Rules 320
 - Feature Information 320
 - Feature Description 321
 - How It Works 321
 - Configuring Loop Prevention for Dynamic Rules 321
 - Monitoring and Troubleshooting 322
- Separation of Accounting Interim Interval Timer for RADIUS and Diameter Rf 323
 - Feature Information 323
 - Feature Description 323
 - How It Works 324
 - Configuring Diameter Accounting Interim Interval 325
 - Monitoring and Troubleshooting 325
- Enhancement to OCS Failure Reporting for Gy 326
 - Feature Information 326
 - Feature Description 327
- Support Added for RAN/NAS Cause Code for S5/S8 and S2b Interfaces 327
 - Feature Information 327
 - Feature Changes 328
 - Command Changes 332

APPENDIX H

- Gy Interface Support 333**
 - Introduction 333
 - License Requirements 334
 - Supported Standards 335
 - Features and Terminology 335
 - Charging Scenarios 335
 - Session Charging with Reservation 335
 - Basic Operations 336
 - Re-authorization 336
 - Threshold based Re-authorization Triggers 337
 - Termination Action 337
 - Diameter Base Protocol 337
 - Diameter Credit Control Application 338

Quota Behavior	338
Supported AVPs	351
Unsupported AVPs	354
PLMN and Time Zone Reporting	359
Interworking between Session-based Gy and Event-based Gy	360
OCS Unreachable Failure Handling Feature	360
Enhancement to OCS Failure Reporting for Gy	362
Feature Description	362
Backpressure Handling	362
Gy Backpressure Enhancement	363
Gy Support for GTP based S2a/S2b	363
Generating OOC/ROC with Changing Association between Rule and RG	364
Static Rulebase for CCR	364
CC based Selective Gy Session Control	364
Feature Description	365
Configuring CC based Selective Gy Session Control	365
Monitoring and Troubleshooting the Selective Gy Session Control Feature	366
Credit-Control Group in Rulebase Configuration	366
Feature Description	367
Configuring Credit-Control Group in Rulebase	368
Monitoring and Troubleshooting the CC-Group Selection in Rulebase	368
Combined CCR-U Triggering for QoS Change Scenarios	369
Re-activating Offline Gy Session after Failure	369
Feature Description	369
Configuring Offline Gy Session after Failure	370
Monitoring and Troubleshooting the Offline Gy Session after Failure	371
Suppress AVPs	371
Feature Description	371
Command Changes	372
Performance Indicator Changes	372
Configuring Gy Interface Support	372
Configuring GGSN / P-GW / IPSG Gy Interface Support	373
Configuring HA / PDSN Gy Interface Support	374
Configuring PLMN and Time Zone Reporting	375

Configuring Server Unreachable Feature	376
Configuring Static Rulebase for CCR	377
Configuring Gy for GTP based S2a/S2b	377
Gathering Statistics	378

APPENDIX I
IP Header Compression 379

Overview	379
Configuring VJ Header Compression for PPP	380
Enabling VJ Header Compression	381
Verifying the VJ Header Compression Configuration	381
Configuring RoHC Header Compression for PPP	381
Enabling RoHC Header Compression for PPP	382
Verifying the Header Compression Configuration	382
Configuring Both RoHC and VJ Header Compression	382
Enabling RoHC and VJ Header Compression for PPP	383
Verifying the Header Compression Configuration	383
Configuring RoHC for Use with SO67 in PDSN or HSGW Service	384
Enabling RoHC Header Compression with PDSN	384
Enabling RoHC Header Compression with HSGW	385
Verifying the Header Compression Configuration	385
Using an RoHC Profile for Subscriber Sessions	385
Creating RoHC Profile for Subscriber using Compression Mode	386
Creating RoHC Profile for Subscriber using Decompression Mode	387
Applying RoHC Profile to a Subscriber	387
Verifying the Header Compression Configuration	388
Disabling VJ Header Compression Over PPP	388
Disabling VJ Header Compression	388
Verifying the VJ Header Compression Configuration	389
Disabling RoHC Header Compression Over SO67	389
Disabling RoHC Header Compression	390
Verifying the Header Compression Configuration	390
Checking IP Header Compression Statistics	390
RADIUS Attributes for IP Header Compression	391

APPENDIX J**IP Pool Sharing Protocol 393**

Overview 393

Primary HA Functionality 393

Secondary HA Functionality 394

Requirements, Limitations, & Behavior 394

How IPSP Works 395

IPSP Operation for New Sessions 395

IPSP Operation for Session Handoffs 396

Configuring IPSP Before the Software Upgrade 398

Configuring the AAA Server for IPSP 398

Enabling IPSP on the Secondary HA 399

Enabling IPSP on the Primary HA 399

Verifying the IPSP Configuration 400

Configuring IPSP After the Software Upgrade 400

Disabling IPSP 401

APPENDIX K**Intelligent Traffic Control 403**

Overview 403

ITC and EV-DO Rev A in 3GPP2 Networks 404

Bandwidth Control and Limiting 404

Licensing 404

How it Works 404

Configuring Flow-based Traffic Policing 405

Configuring Class Maps 406

Configuring Policy Maps 407

Configuring Policy Groups 407

Configuring a Subscriber for Flow-based Traffic Policing 408

Verifying Flow-based Traffic Policing Configuration 408

APPENDIX L**L2TP Access Concentrator 409**

Applicable Products and Relevant Sections 410

Supported LAC Service Configurations for PDSN Simple IP 411

Attribute-based Tunneling 412

How The Attribute-based L2TP Configuration Works	412
Configuring Attribute-based L2TP Support for PDSN Simple IP	413
PDSN Service-based Compulsory Tunneling	414
How PDSN Service-based Compulsory Tunneling Works	414
Configuring L2TP Compulsory Tunneling Support for PDSN Simple IP	416
Supported LAC Service Configurations for the GGSN and P-GW	416
Transparent IP PDP Context Processing with L2TP Support	418
Non-transparent IP PDP Context Processing with L2TP Support	419
PPP PDP Context Processing with L2TP Support	420
Configuring the GGSN or P-GW to Support L2TP	422
Supported LAC Service Configuration for Mobile IP	422
How The Attribute-based L2TP Configuration for MIP Works	423
Configuring Attribute-based L2TP Support for HA Mobile IP	424
Configuring Subscriber Profiles for L2TP Support	425
RADIUS and Subscriber Profile Attributes Used	425
RADIUS Tagging Support	427
Configuring Local Subscriber Profiles for L2TP Support	427
Configuring Local Subscriber	428
Verifying the L2TP Configuration	428
Tunneling All Subscribers in a Specific Context Without Using RADIUS Attributes	429
Feature Description	429
Configuring LAC Services	429
Configuring LAC Service	430
Configuring Multicast Services over L2TP	430
Configuring LNS Peer	431
Verifying the LAC Service Configuration	431
Modifying PDSN Services for L2TP Support	431
Modifying PDSN Service	432
Verifying the PDSN Service for L2TP Support	432
Modifying APN Templates to Support L2TP	433
Assigning LNS Peer Address in APN Template	433
Configuring Outbound Authentication	434
Verifying the APN Configuration	434

APPENDIX M	L2TP Network Server	435
	LNS Service Operation	436
	Information Required	436
	Source Context Configuration	436
	Destination Context Configuration	441
	How This Configuration Works	443
	Configuring the System to Support LNS Functionality	444
	Creating and Binding LNS Service	445
	Configuring Authentication Parameters for LNS Service	445
	Configuring Tunnel and Session Parameters for LNS Service	445
	Configuring Peer LAC servers for LNS Service	446
	Configuring Domain Alias for AAA Subscribers	446
	Verifying the LNS Service Configuration	446

APPENDIX N	Mobile IP Registration Revocation	449
	Overview	449
	Configuring Registration Revocation	450
	Configuring FA Services	451
	Configuring HA Services	451

APPENDIX O	Policy Forwarding	453
	Overview	453
	IP Pool-based Next Hop Forwarding	454
	Configuring IP Pool-based Next Hop Forwarding	454
	Subscriber-based Next Hop Forwarding	454
	Configuring Subscriber-based Next Hop Forwarding	454
	ACL-based Policy Forwarding	454
	Configuring ACL-based Policy Forwarding	455
	Applying the ACL to an IP Access Group	455
	Applying the ACL to a Destination Context	455
	Applying the ACL to an Interface in a Destination Context	455

APPENDIX P	Pre-paid Billing	457
-------------------	-------------------------	------------

- Overview **457**
 - 3GPP2 Standard Pre-paid Billing Overview **457**
 - Custom Pre-paid Billing Overview **458**
 - License Requirements **458**
- Configuring Standard 3GPP2 Pre-paid Billing **458**
- Configuring Pre-paid Billing With Custom Behavior **459**
- 3GPP2 Pre-paid Attributes **461**
- Pre-paid Attributes **464**

APPENDIX Q

- Proxy-Mobile IP 467**
 - Overview **467**
 - Proxy Mobile IP in 3GPP2 Service **469**
 - Proxy Mobile IP in 3GPP Service **470**
 - Proxy Mobile IP in WiMAX Service **470**
 - How Proxy Mobile IP Works in 3GPP2 Network **470**
 - Scenario 1: AAA server and PDSN/FA Allocate IP Address **471**
 - Scenario 2: HA Allocates IP Address **474**
 - How Proxy Mobile IP Works in 3GPP Network **477**
 - How Proxy Mobile IP Works in WiMAX Network **482**
 - Scenario 1: AAA server and ASN GW/FA Allocate IP Address **482**
 - Scenario 2: HA Allocates IP Address **485**
 - How Proxy Mobile IP Works in a WiFi Network with Multiple Authentication **488**
 - Configuring Proxy Mobile-IP Support **495**
 - Configuring FA Services **496**
 - Verify the FA Service Configuration **496**
 - Configuring Proxy MIP HA Failover **497**
 - Configuring Subscriber Profile RADIUS Attributes **497**
 - Configuring Subscriber Profile RADIUS Attributes **498**
 - RADIUS Attributes Required for Proxy Mobile IP **498**
 - Configuring Local Subscriber Profiles for Proxy-MIP on a PDSN **499**
 - Configuring Local Subscriber Profiles for Proxy-MIP on a PDIF **500**
 - Configuring Default Subscriber Parameters in Home Agent Context **500**
 - Configuring APN Parameters **500**

APPENDIX R	Rejection/Redirection of HA Sessions on Network Failures	503
	Overview	503
	Configuring HA Session Redirection	504
	RADIUS Attributes	507

APPENDIX S	Remote Address-based RADIUS Accounting	509
	Overview	509
	License Requirements	509
	Configuring Remote Address-based Accounting	510
	Verifying the Remote Address Lists	510
	Subscriber Attribute Configuration	510
	Supported RADIUS Attributes	511
	Configuring Local Subscriber Profiles	511

APPENDIX T	Traffic Policing and Shaping	513
	Feature Description	513
	Traffic Policing	513
	Traffic Shaping	514
	Traffic Policing Configuration	514
	Configuring Subscribers for Traffic Policing	515
	Configuring APN for Traffic Policing in 3GPP Networks	516
	Traffic Shaping Configuration	517
	Configuring Subscribers for Traffic Shaping	517
	Configuring APN for Traffic Shaping in 3GPP Networks	518
	Configuring Traffic Shaping	519
	Configuring Subscribers for Traffic Shaping	519
	Configuring APN for Traffic Shaping in 3GPP Networks	520
	RADIUS Attributes	522
	Traffic Policing for CDMA Subscribers	522
	Traffic Policing for UMTS Subscribers	523



About this Guide

This preface describes the Packet Data Serving Node Administration Guide, how it is organized and its document conventions.

Packet Data Serving Node Gateway (PDSN) is a StarOS application that runs on Cisco® ASR 5500 and virtualized platforms. The ASR 5500 provides wireless carriers with a flexible solution that functions as a Packet Data Support Node (PDSN) in CDMA 2000 wireless data networks.

- [Conventions Used, on page xxi](#)
- [Supported Documents and Resources, on page xxiii](#)

Conventions Used

The following tables describe the conventions used throughout this documentation.

Notice Type	Description
Information Note	Provides information about important features or instructions.
Caution	Alerts you of potential damage to a program, device, or system.
Warning	Alerts you of potential personal injury or fatality. May also alert you of potential electrical hazards.

Typeface Conventions	Description
Text represented as a screen display	This typeface represents displays that appear on your terminal screen, for example: Login:
Text represented as commands	This typeface represents commands that you enter, for example: show ip access-list This document always gives the full form of a command in lowercase letters. Commands are not case sensitive.

Typeface Conventions	Description
Text represented as a command <i>variable</i>	This typeface represents a variable that is part of a command, for example: show card <i>slot_number</i> <i>slot_number</i> is a variable representing the desired chassis slot number.
Text represented as menu or sub-menu names	This typeface represents menus and sub-menus that you access within a software application, for example: Click the File menu, then click New
Command Syntax Conventions	Description
{ keyword or <i>variable</i> }	Required keyword options and variables are those components that are required to be entered as part of the command syntax. Required keyword options and variables are surrounded by grouped braces { }. For example: sctp-max-data-chunks { limit <i>max_chunks</i> mtu-limit } If a keyword or variable is not enclosed in braces or brackets, it is mandatory. For example: snmp trap link-status
[keyword or <i>variable</i>]	Optional keywords or variables, or those that a user may or may not choose to use, are surrounded by brackets.
	Some commands support multiple options. These are documented within braces or brackets by separating each option with a vertical bar. These options can be used in conjunction with required or optional keywords or variables. For example: action activate-flow-detection { initiation termination } or ip address [count <i>number_of_packets</i> size <i>number_of_bytes</i>]

Supported Documents and Resources

Related Common Documentation

The following common documents are available:

- *AAA Interface Administration and Reference*
- *Command Line Interface Reference*
- *GTPP Interface Administration and Reference*
- *Installation Guide* (platform dependant)
- *Release Change Reference*
- *SNMP MIB Reference*
- *Statistics and Counters Reference*
- *System Administration Guide* (platform dependant)
- *Thresholding Configuration Guide*

Related Product Documentation

The most up-to-date information for this product is available in the product Release Notes provided with each product release.

The following product documents are also available and work in conjunction with the PDSN:

- *ADC Administration Guide*
- *CF Administration Guide*
- *ECS Administration Guide*
- *ePDG Administration Guide*
- *GGSN Administration Guide*
- *HA Administration Guide*
- *HSGW Administration Guide*
- *IPSec Reference*
- *MME Administration Guide*
- *NAT Administration Guide*
- *PSF Administration Guide*
- *P-GW Administration Guide*
- *SAEGW Administration Guide*
- *SaMOG Administration Guide*
- *SecGW Administration Guide*
- *SGSN Administration Guide*
- *S-GW Administration Guide*

Obtaining Documentation

The most current Cisco documentation is available on the following website:

<http://www.cisco.com/cisco/web/psa/default.html>

Use the following path selections to access the Packet Data Serving Node Administration Guide documentation:

Products > Wireless > Mobile Internet> Network Functions > Cisco PDSN/HA Packet Data Serving Node and Home Agent

Contacting Customer Support

Use the information in this section to contact customer support.

Refer to the support area of <http://www.cisco.com> for up-to-date product documentation or to submit a service request. A valid username and password are required to access this site. Please contact your Cisco sales or service representative for additional information.



CHAPTER 1

CDMA2000 Wireless Data Services

The ASR 5500 provides wireless carriers with a flexible solution that functions as a Packet Data Support Node (PDSN) in CDMA 2000 wireless data networks.

This overview provides general information about the PDSN including:

- [Product Description, on page 1](#)
- [Qualified Platforms, on page 2](#)
- [Features and Functionality—Base Software, on page 2](#)
- [Features and Functionality - Optional Enhanced Software Features, on page 11](#)
- [Features and Functionality - Inline Service Support, on page 18](#)
- [Features and Functionality - External Application Support, on page 21](#)
- [CDMA2000 Data Network Deployment Configurations, on page 21](#)
- [Understanding Simple IP and Mobile IP, on page 24](#)
- [Supported Standards, on page 41](#)

Product Description

The system provides wireless carriers with a flexible solution that can support both Simple IP and Mobile IP applications (independently or simultaneously) within a single scalable platform.

When supporting Simple IP data applications, the system is configured to perform the role of a Packet Data Serving Node (PDSN) within the carrier's 3G CDMA2000 data network. The PDSN terminates the mobile subscriber's Point-to-Point Protocol (PPP) session and then routes data to and from the Packet Data Network (PDN) on behalf of the subscriber. The PDN could consist of Wireless Application Protocol (WAP) servers or it could be the Internet.

When supporting Mobile IP and/or Proxy Mobile IP data applications, the system can be configured to perform the role of the PDSN/Foreign Agent (FA) and/or the Home Agent (HA) within the carrier's 3G CDMA2000 data network. When functioning as an HA, the system can either be located within the carrier's 3G network or in an external enterprise or ISP network. Regardless, the PDSN/FA terminates the mobile subscriber's PPP session, and then routes data to and from the appropriate HA on behalf of the subscriber.

Qualified Platforms

PDSN is a StarOS application that runs on Cisco ASR 5500 and virtualized platforms. For additional platform information, refer to the appropriate System Administration Guide and/or contact your Cisco account representative.

Features and Functionality—Base Software

This section describes the features and functions supported by default in base software on PDSN service and do not require any additional licenses.



Important

To configure the basic service and functionality on the system for PDSN service, refer to the configuration examples provided in the PDSN Administration Guide.

This section describes following features:

- [Gx and Gy Support, on page 2](#)
- [RADIUS Support, on page 3](#)
- [Access Control List Support, on page 4](#)
- [IP Policy Forwarding, on page 5](#)
- [AAA Server Groups, on page 6](#)
- [Overlapping IP Address Pool Support, on page 6](#)
- [Routing Protocol Support, on page 6](#)
- [Management System Overview, on page 8](#)
- [Bulk Statistics Support, on page 9](#)
- [Threshold Crossing Alerts \(TCA\) Support, on page 10](#)
- [IP Header Compression - Van Jacobson, on page 10](#)
- [DSCP Marking, on page 11](#)

Gx and Gy Support

The PDSN supports 3GPP Release 8 standards based policy interface with the Policy and Charging Rules Function (PCRF). The policy interface is based on a subset 3GPP 29.212. based Gx interface specification. The PDSN policy interface fully supports installation/modification of dynamic and predefined rules from the PCRF.

The enforcement of dynamic and predefined PCC rules installed from the PCRF is done using Enhanced Charging Services (ECS).The full ECS functionality including the DPI and P2P detection can be enabled via predefined rules using the Gx interface.

The PDSN supports a subset of event triggers as defined in 29.212. Currently the event trigger support is limited to the following:

- RAT Change
- User location change (BSID)

- AN GW change (during inter PCF handoff)

The PDSN also supports triggering of online charging via the policy interface. 3GPP Release 8 Gy interface as defined in 32.299 is used for online charging.

The PDSN supports connectivity to multiple PCRF's. The PCRF's may be referred to by an FQDN. Load balancing of sessions across multiple servers are achieved by using a round robin algorithm. Redundancy between servers can be achieved by configuring multiple weighted sets of servers.

The configuration allows Policy support to be enabled on a per subscriber/APN basis.

The policy features supported on PDSN and GGSN will be quite similar. On PDSN the Gx will only be supported for Simple IP calls.

On PDSN additional event triggers rat type change and location change will be supported. On PDSN Gy , standard DCCA based credit control is supported 3GPP related trigger functionality is not supported on PDSN Gy.

RADIUS Support

Provides a mechanism for performing authorization, authentication, and accounting (AAA) for subscriber PDP contexts based on the following standards:

- RFC-2618, RADIUS Authentication Client MIB, June 1999
- RFC-2620, RADIUS Accounting Client MIB, June 1999
- RFC-2865, Remote Authentication Dial In User Service (RADIUS), June 2000
- RFC-2866, RADIUS Accounting, June 2000
- RFC-2867, RADIUS Accounting Modifications for Tunnel Protocol Support, June 2000
- RFC-2868, RADIUS Attributes for Tunnel Protocol Support, June 2000
- RFC-2869, RADIUS Extensions, June 2000

Description

The Remote Authentication Dial-In User Service (RADIUS) protocol is used to provide AAA functionality for subscriber PDP contexts.

Within context contexts configured on the system, there are AAA and RADIUS protocol-specific parameters that can be configured. The RADIUS protocol-specific parameters are further differentiated between RADIUS Authentication server RADIUS Accounting server interaction.

Among the RADIUS parameters that can be configured are:

- **Priority:** Dictates the order in which the servers are used allowing for multiple servers to be configured in a single context.
- **Routing Algorithm:** Dictate the method for selecting among configured servers. The specified algorithm dictates how the system distributes AAA messages across the configured AAA servers for new sessions. Once a session is established and an AAA server has been selected, all subsequent AAA messages for the session will be delivered to the same server.

In the event that a single server becomes unreachable, the system attempts to communicate with the other servers that are configured. The system also provides configurable parameters that specify how it should behave should all of the RADIUS AAA servers become unreachable.

The system provides an additional level of flexibility by supporting the configuration RADIUS server groups. This functionality allows operators to differentiate AAA services based on the subscriber template used to facilitate their PDP context.

In general, 128 AAA Server IP address/port per context can be configured on the system and it selects servers from this list depending on the server selection algorithm (round robin, first server). Instead of having a single list of servers per context, this feature provides the ability to configure multiple server groups. Each server group, in turn, consists of a list of servers.

This feature works in following way:

- All RADIUS authentication/accounting servers configured at the context-level are treated as part of a server group named "default". This default server group is available to all subscribers in that context through the realm (domain) without any configuration.
- It provides a facility to create "user defined" RADIUS server groups, as many as 399 (excluding "default" server group), within a context. Any of the user defined RADIUS server groups are available for assignment to a subscriber through the subscriber configuration within that context.

Since the configuration of the subscriber can specify the RADIUS server group to use as well as IP address pools from which to assign addresses, the system implements a mechanism to support some in-band RADIUS server implementations (i.e. RADIUS servers which are located in the corporate network, and not in the operator's network) where the NAS-IP address is part of the subscriber pool. In these scenarios, the PDSN supports the configuration of the first IP address of the subscriber pool for use as the RADIUS NAS-IP address.



Important

In 12.3 and earlier releases, refer to the *AAA and GTPP Interface Administration and Reference* for more information on RADIUS AAA configuration. In 14.0 and later releases, refer to the *AAA Interface Administration and Reference*.

Access Control List Support

Access Control Lists provide a mechanism for controlling (i.e permitting, denying, redirecting, etc.) packets in and out of the system.

IP access lists, or Access Control Lists (ACLs) as they are commonly referred to, are used to control the flow of packets into and out of the system. They are configured on a per-context basis and consist of "rules" (ACL rules) or filters that control the action taken on packets that match the filter criteria. Once configured, an ACL can be applied to any of the following:

- An individual interface
- All traffic facilitated by a context (known as a policy ACL)
- An individual subscriber
- All subscriber sessions facilitated by a specific context

There are two primary components of an ACL:

- **Rule:** A single ACL consists of one or more ACL rules. As discussed earlier, the rule is a filter configured to take a specific action on packets matching specific criteria. Up to 128 rules can be configured per ACL.

Each rule specifies the action to take when a packet matches the specifies criteria. This section discusses the rule actions and criteria supported by the system.

- **Rule Order:** A single ACL can consist of multiple rules. Each packet is compared against each of the ACL rules, in the order in which they were entered, until a match is found. Once a match is identified, all subsequent rules are ignored.

**Important**

For more information on Access Control List configuration, refer to the IP Access Control List chapter in System Administration Guide.

IP Policy Forwarding

IP Policy Forwarding enables the routing of subscriber data traffic to specific destinations based on configuration. This functionality can be implemented in support of enterprise-specific applications (i.e. routing traffic to specific enterprise domains) or for routing traffic to back-end servers for additional processing.

Description

The system can be configured to automatically forward data packets to a predetermined network destination. This can be done in one of three ways:

- **IP Pool-based Next Hop Forwarding** - Forwards data packets based on the IP pool from which a subscriber obtains an IP address.
- **ACL-based Policy Forwarding** - Forwards data packets based on policies defined in Access Control Lists (ACLs) and applied to contexts or interfaces.
- **Subscriber specific Next Hop Forwarding** - Forwards all packets for a specific subscriber.

The simplest way to forward subscriber data is to use IP Pool-based Next Hop Forwarding. An IP pool is configured with the address of a next hop gateway and data packets from all subscribers using the IP pool are forward to that gateway.

Subscriber Next Hop forwarding is also very simple. In the subscriber configuration a nexthop forwarding address is specified and all data packets for that subscriber are forwarded to the specified nexthop destination.

ACL-based Policy Forwarding gives you more control on redirecting data packets. By configuring an Access Control List (ACL) you can forward data packets from a context or an interface by different criteria, such as source or destination IP address, ICMP type, or TCP/UDP port numbers.

ACLs are applied first. If ACL-based Policy Forwarding and Pool-based Next Hop Forwarding or Subscriber are configured, data packets are first redirected as defined in the ACL, then all remaining data packets are redirected to the next hop gateway defined by the IP pool or subscriber profile.

**Important**

For more information on IP Policy Forwarding configuration, refer to the Policy Forwarding chapter.

AAA Server Groups

Value-added feature to enable VPN service provisioning for enterprise or MVNO customers. Enables each corporate customer to maintain its own AAA servers with its own unique configurable parameters and custom dictionaries.

Description

This feature provides support for up to 800 AAA (RADIUS and Diameter) server groups and 800 NAS IP addresses that can be provisioned within a single context or across the entire chassis. A total of 128 servers can be assigned to an individual server group. Up to 1,600 accounting, authentication and/or mediation servers are supported per chassis and may be distributed across a maximum of 1,000 subscribers. This feature also enables the AAA servers to be distributed across multiple subscribers within the same context.



Important

Due to additional memory requirements, this service can only be used with 8GB Packet Accelerator Cards (PACs) or Packet Service Cards (PSCs)



Important

For more information on AAA Server Group configuration, refer to the *AAA Interface Administration and Reference*.

Overlapping IP Address Pool Support

Overlapping IP Address Pools provides a mechanism for allowing operators to more flexibly support multiple corporate VPN customers with the same private IP address space without the expensive investments in physically separate routers, or expensive configurations using virtual routers.



Important

For more information on IP pool overlapping configuration, refer to the VLANs chapter in the *System Administration Guide*.

Routing Protocol Support

The system's support for various routing protocols and routing mechanism provides an efficient mechanism for ensuring the delivery of subscriber data packets.

Description

The following routing mechanisms and protocols are supported by the system:

- **Static Routes:** The system supports the configuration of static network routes on a per context basis. Network routes are defined by specifying an IP address and mask for the route, the name of the interface in the current context that the route must use, and a next hop IP address.
- **Open Shortest Path First (OSPF) Protocol version 2:** A link-state routing protocol, OSPF is an Interior Gateway Protocol (IGP) that routes IP packets based solely on the destination IP address found in the IP

packet header using the shortest path first. IP packets are routed "as is", meaning they are not encapsulated in any further protocol headers as they transit the network.

Variable length subnetting, areas, and redistribution into and out of OSPF are supported.

OSPF routing is supported in accordance with the following standards:

- RFC-1850, OSPF Version 2 Management Information Base, November 1995
- RFC-2328, OSPF Version 2, April 1998
- RFC-3101 OSPF-NSSA Option, January 2003

- **Border Gateway Protocol version 4 (BGP-4):** The system supports a subset of BGP (RFC-1771, A Border Gateway Protocol 4 (BGP-4)), suitable for eBGP support of multi-homing typically used to support geographically redundant mobile gateways, is supported.

EBGP is supported with multi-hop, route filtering, redistribution, and route maps. The network command is support for manual route advertisement or redistribution.

BGP route policy and path selection is supported by the following means:

- Prefix match based on route access list
 - AS path access-list
 - Modification of AS path through path prepend
 - Origin type
 - MED
 - Weight
- **Route Policy:** Routing policies modify and redirect routes to and from the system to satisfy specific routing needs. The following methods are used with or without active routing protocols (i.e. static or dynamic routing) to prescribe routing policy:
 - **Route Access Lists:** The basic building block of a routing policy, route access lists filter routes based upon a specified range of IP addresses.
 - **IP Prefix Lists:** A more advanced element of a routing policy. An IP Prefix list filters routes based upon IP prefixes.
 - **AS Path Access Lists:** A basic building block used for Border Gateway Protocol (BGP) routing, these lists filter Autonomous System (AS) paths.
 - **Route Maps:** Route-maps are used for detailed control over the manipulation of routes during route selection or route advertisement by a routing protocol and in route redistribution between routing protocols. This detailed control is achieved using IP Prefix Lists, Route Access Lists and AS Path Access Lists to specify IP addresses, address ranges, and Autonomous System Paths.
 - **Equal Cost Multiple Path:** ECMP allows distribution of traffic across multiple routes that have the same cost to the destination. In this manner, throughput load is distributed across multiple paths, typically to lessen the burden on any one route and provide redundancy.

**Important**

For more information on IP Routing configuration, refer to the *Routing* chapter in the *System Administration Guide*.

Management System Overview

The system's management capabilities are designed around the Telecommunications Management Network (TMN) model for management -- focusing on providing superior quality Network Element (NE) and element management system (Web Element Manager) functions. The system provides element management applications that can easily be integrated, using standards-based protocols (CORBA and SNMPv1, v2), into higher-level management systems -- giving wireless operators the ability to integrate the system into their overall network, service, and business management systems. In addition, all management is performed out-of-band for security and to maintain system performance.

Description

Cisco's O&M module offers comprehensive management capabilities to the operators and enables them to operate the system more efficiently. There are multiple ways to manage the system either locally or remotely using its out-of-band management interfaces.

These include:

- Using the Command Line Interface (CLI)
- Remote login using Telnet, and Secure Shell (SSH) access to CLI through SPIO card's Ethernet management interfaces
- Local login through the Console port on SPIO card using an RS-232 serial connection
- Using the Web Element Manager application
- Supports communications through 10 Base-T, 100 Base-TX, 1000 Base-TX, or 1000
- Base-SX (optical gigabit Ethernet) Ethernet management interfaces on the SPIO
- Client-Server model supports any browser (i.e. Microsoft Internet Explorer v5.0 and above or Netscape v4.7 or above, and others)
- Supports Common Object Request Broker Architecture (CORBA) protocol and Simple Network Management Protocol version 1 (SNMPv1) for fault management
- Provides complete Fault, Configuration, Accounting, Performance, and Security (FCAPS) capabilities
- Can be easily integrated with higher-level network, service, and business layer applications using the Object Management Group's (OMG's) Interface Definition Language (IDL)

**Important**

For more information on command line interface based management, refer to the *Command Line Interface Reference* and *PDSN Administration Guide*.

Bulk Statistics Support

The system's support for bulk statistics allows operators to choose to view not only statistics that are of importance to them, but also to configure the format in which it is presented. This simplifies the post-processing of statistical data since it can be formatted to be parsed by external, back-end processors.

When used in conjunction with the Web Element Manager, the data can be parsed, archived, and graphed.

Description

The system can be configured to collect bulk statistics (performance data) and send them to a collection server (called a receiver). Bulk statistics are statistics that are collected in a group. The individual statistics are grouped by schema. The following schemas are supported:

- **System:** Provides system-level statistics
- **Card:** Provides card-level statistics
- **Port:** Provides port-level statistics
- **BCMCS:** Provides BCMCS service statistics
- **FA:** Provides FA service statistics
- **HA:** Provides HA service statistics
- **IP Pool:** Provides IP pool statistics
- **MIPv6HA:** Provides MIPv6HA service statistics
- **PPP:** Provides Point-to-Point Protocol statistics
- **RADIUS:** Provides per-RADIUS server statistics
- **ECS:** Provides Enhanced Charging Service Statistics

The system supports the configuration of up to 4 sets (primary/secondary) of receivers. Each set can be configured with to collect specific sets of statistics from the various schemas. Statistics can be pulled manually from the IMG or sent at configured intervals. The bulk statistics are stored on the receiver(s) in files.

The format of the bulk statistic data files can be configured by the user. Users can specify the format of the file name, file headers, and/or footers to include information such as the date, IMG host name, IMG uptime, the IP address of the system generating the statistics (available for only for headers and footers), and/or the time that the file was generated.

When the Web Element Manager is used as the receiver, it is capable of further processing the statistics data through XML parsing, archiving, and graphing.

The Bulk Statistics Server component of the Web Element Manager parses collected statistics and stores the information in the PostgreSQL database. If XML file generation and transfer is required, this element generates the XML output and can send it to a Northbound NMS or an alternate bulk statistics server for further processing.

Additionally, if archiving of the collected statistics is desired, the Bulk Statistics server writes the files to an alternative directory on the server. A specific directory can be configured by the administrative user or the default directory can be used. Regardless, the directory can be on a local file system or on an NFS-mounted file system on the Web Element Manager server.

Threshold Crossing Alerts (TCA) Support

Thresholding on the system is used to monitor the system for conditions that could potentially cause errors or outage. Typically, these conditions are temporary (i.e high CPU utilization, or packet collisions on a network) and are quickly resolved. However, continuous or large numbers of these error conditions within a specific time interval may be indicative of larger, more severe issues. The purpose of thresholding is to help identify potentially severe conditions so that immediate action can be taken to minimize and/or avoid system downtime.

The system supports Threshold Crossing Alerts for certain key resources such as CPU, memory, IP pool addresses, etc. With this capability, the operator can configure threshold on these resources whereby, should the resource depletion cross the configured threshold, a SNMP Trap would be sent.

Description

The following thresholding models are supported by the system:

- **Alert:** A value is monitored and an alert condition occurs when the value reaches or exceeds the configured high threshold within the specified polling interval. The alert is generated then generated and/or sent at the end of the polling interval.
- **Alarm:** Both high and low threshold are defined for a value. An alarm condition occurs when the value reaches or exceeds the configured high threshold within the specified polling interval. The alert is generated then generated and/or sent at the end of the polling interval.

Thresholding reports conditions using one of the following mechanisms:

- **SNMP traps:** SNMP traps have been created that indicate the condition (high threshold crossing and/or clear) of each of the monitored values.

Generation of specific traps can be enabled or disabled on the chassis. Ensuring that only important faults get displayed. SNMP traps are supported in both Alert and Alarm modes.

- **Logs:** The system provides a facility called threshold for which active and event logs can be generated. As with other system facilities, logs are generated Log messages pertaining to the condition of a monitored value are generated with a severity level of WARNING.

Logs are supported in both the Alert and the Alarm models.

- **Alarm System:** High threshold alarms generated within the specified polling interval are considered "outstanding" until a the condition no longer exists or a condition clear alarm is generated. "Outstanding" alarms are reported to the system's alarm subsystem and are viewable through the Alarm Management menu in the Web Element Manager.

The Alarm System is used only in conjunction with the Alarm model.



Important

For more information on threshold crossing alert configuration, refer to the *Thresholding Configuration Guide*.

IP Header Compression - Van Jacobson

Implementing IP header compression provides the following benefits:

- Improves interactive response time

- Allows the use of small packets for bulk data with good line efficiency
- Allows the use of small packets for delay sensitive low data-rate traffic
- Decreases header overhead
- Reduces packet loss rate over lossy links

Description

The system supports the Van Jacobson (VJ) IP header compression algorithms by default for subscriber traffic.

The VJ header compression is supported as per RFC 1144 (CTCP) header compression standard developed by V. Jacobson in 1990. It is commonly known as VJ compression. It describes a basic method for compressing the headers of IPv4/TCP packets to improve performance over low speed serial links.

By default IP header compression using the VJ algorithm is enabled for subscribers. You can also turn off IP header compression for a subscriber.



Important

For more information on IP header compression support, refer to the IP Header Compression chapter.

DSCP Marking

Provides support for more granular configuration of DSCP marking.

For different Traffic class, the PDSN supports per-service and per-subscriber configurable DSCP marking for Uplink and Downlink direction based on Allocation/Retention Priority in addition to the current priorities.

Features and Functionality - Optional Enhanced Software Features

This section describes the optional enhanced features and functions for PDSN service.

Each of the following features require the purchase of an additional license to implement the functionality with the PDSN service.

This section describes following features:

- [Session Recovery Support, on page 12](#)
- [IPv6 Support , on page 12](#)
- [L2TP LAC Support, on page 13](#)
- [L2TP LNS Support, on page 14](#)
- [Proxy Mobile IP, on page 14](#)
- [IP Security \(IPSec\), on page 15](#)
- [Traffic Policing and Rate Limiting, on page 15](#)
- [Dynamic RADIUS Extensions \(Change of Authorization\), on page 17](#)

Session Recovery Support

The Session Recovery feature provides seamless failover and reconstruction of subscriber session information in the event of a hardware or software fault within the system preventing a fully connected user session from being disconnected.

Description

Session recovery is performed by mirroring key software processes (e.g. session manager and AAA manager) within the system. These mirrored processes remain in an idle state (in standby-mode), wherein they perform no processing, until they may be needed in the case of a software failure (e.g. a session manager task aborts). The system spawns new instances of "standby mode" session and AAA managers for each active Control Processor (CP) being used.

Additionally, other key system-level software tasks, such as VPN manager, are performed on a physically separate Packet Services Card (PSC) to ensure that a double software fault (e.g. session manager and VPN manager fails at same time on same card) cannot occur. The PSC used to host the VPN manager process is in active mode and is reserved by the operating system for this sole use when session recovery is enabled.

The additional hardware resources required for session recovery include a standby System Processor Card (SPC) and a standby PSC.

There are two modes for Session Recovery.

- **Task recovery mode:** Wherein one or more session manager failures occur and are recovered without the need to use resources on a standby PSC. In this mode, recovery is performed by using the mirrored "standby-mode" session manager task(s) running on active PACs. The "standby-mode" task is renamed, made active, and is then populated using information from other tasks such as AAA manager.
- **Full recovery mode:** Used when a PSC hardware failure occurs, or when a PSC migration failure happens. In this mode, the standby PSC is made active and the "standby-mode" session manager and AAA manager tasks on the newly activated PSC perform session recovery.

Session/Call state information is saved in the peer AAA manager task because each AAA manager and session manager task is paired together. These pairs are started on physically different PACs to ensure task recovery.



Important

For more information on session recovery support, refer to the Session Recovery chapter in the *System Administration Guide*.

IPv6 Support

This feature allows IPv6 subscribers to connect via the CDMA 2000 infrastructure in accordance with the following standards:

- RFC 2460: Internet Protocol, Version 6 (IPv6) Specification
- RFC 2461: Neighbor Discovery for IPv6
- RFC 2462: IPv6 Stateless Address Autoconfiguration
- RFC 3314: Recommendations for IPv6 in 3GPP Standards
- RFC 3316: Internet Protocol Version 6 (IPv6) for Some Second and Third Generation Cellular Hosts

- RFC 3056: Connection of IPv6 domains via IPv4 clouds
- 3GPP TS 23.060: General Packet Radio Service (GPRS) Service description
- 3GPP TS 27.060: Mobile Station Supporting Packet Switched Services
- 3GPP TS 29.061: Interworking between the Public Land Mobile Network (PLMN) supporting Packet Based Services and Packet Data Networks (PDN)

Description

The PDSN allows a subscriber to be configured for IPv6 PDP contexts. Also, a subscriber may be configured to simultaneously allow IPv4 PDP contexts.

The PDSN supports IPv6 stateless dynamic auto-configuration. The mobile station may select any value for the interface identifier portion of the address. The link-local address is assigned by the PDSN to avoid any conflict between the mobile station link-local address and the PDSN address. The mobile station uses the interface identifier assigned by the PDSN during the stateless address auto-configuration procedure. Once this has completed, the mobile can select any interface identifier for further communication as long as it does not conflict with the PDSN's interface identifier that the mobile learned through router advertisement messages from the PDSN.

Control and configuration of the above is specified as part of the subscriber configuration on the PDSN, e.g., IPv6 address prefix and parameters for the IPv6 router advertisements. RADIUS VSAs may be used to override the subscriber configuration.

Following IPv6 PDP context establishment, the PDSN can perform either manual or automatic 6to4 tunneling, according to RFC 3056, Connection of IPv6 Domains Via IPv4 Clouds.

L2TP LAC Support

The system configured as a Layer 2 Tunneling Protocol Access Concentrator (LAC) enables communication with L2TP Network Servers (LNSs) for the establishment of secure Virtual Private Network (VPN) tunnels between the operator and a subscriber's corporate or home network.

Description

The use of L2TP in VPN networks is often used as it allows the corporation to have more control over authentication and IP address assignment. An operator may do a first level of authentication, however use PPP to exchange user name and password, and use IPCP to request an address. To support PPP negotiation between the PDSN and the corporation, an L2TP tunnel must be setup in the PDSN running a LAC service.

L2TP establishes L2TP control tunnels between LAC and LNS before tunneling the subscriber PPP connections as L2TP sessions. The LAC service is based on the same architecture as the PDSN and benefits from dynamic resource allocation and distributed message and data processing. This design allows the LAC service to support over 4000 setups per second or a maximum of over 3G of throughput. There can be a maximum up to 65535 sessions in a single tunnel and as many as 500,000 L2TP sessions using 32,000 tunnels per system.

The LAC sessions can also be configured to be redundant, thereby mitigating any impact of hardware or software issues. Tunnel state is preserved by copying the information across processor cards.



Important

For more information on L2TP Access Concentrator support, refer to the L2TP Access Concentrator chapter.

L2TP LNS Support

The system configured as a Layer 2 Tunneling Protocol Network Server (LNS) supports the termination secure Virtual Private Network (VPN) tunnels between from L2TP Access Concentrators (LACs).

Description

The LNS service takes advantage of the high performance PPP processing already supported in the system design and is a natural evolution from the LAC. The LNS can be used as a standalone, or running alongside a PDSN service in the same platform, terminating L2TP services in a cost effective and seamless manner.

L2TP establishes L2TP control tunnels between LAC and LNS before tunneling the subscriber PPP connections as L2TP sessions. There can be a maximum of up to 65535 sessions in a single tunnel and up to 500,000 sessions per LNS.

The LNS architecture is similar to the PDSN and utilizes the concept of a de-multiplexer to intelligently assign new L2TP sessions across the available software and hardware resources on the platform without operator intervention..



Important

For more information on L2TP LNS support, refer to the L2TP Access Concentrator chapter.

Proxy Mobile IP

Mobility for subscriber sessions is provided through the Mobile IP protocol as defined in RFCs 2002-2005. However, some older Mobile Nodes (MNs) do not support the Mobile IP protocol. The Proxy Mobile IP feature provides a mobility solution for these MNs.

Description

For IP PDP contexts using Proxy Mobile IP, the MN establishes a session with the PDSN as it normally would. However, the PDSN/FA performs Mobile IP operations with an HA (identified by information stored in the subscriber's profile) on behalf of the MN (i.e. the MN is only responsible for maintaining the IP PDP context with the PDSN, no Agent Advertisement messages are communicated with the MN).

The MN is assigned an IP address by either the HA, an AAA server, or on a static-basis. The address is stored in a Mobile Binding Record (MBR) stored on the HA. Therefore, as the MN roams through the service provider's network, each time a hand-off occurs, the MN will continue to use the same IP address stored in the MBR on the HA.

Proxy Mobile IP can be performed on a per-subscriber basis based on information contained in their user profile, or for all subscribers facilitated by a specific subscriber. In the case of non-transparent IP PDP contexts, attributes returned from the subscriber's profile take precedence over the configuration of the subscriber.



Important

For more information on Proxy Mobile IP configuration, refer to the *Proxy Mobile IP* chapter.

IP Security (IPSec)

IP Security provides a mechanism for establishing secure tunnels from mobile subscribers to pre-defined endpoints (i.e. enterprise or home networks) in accordance with the following standards:

- RFC 2401, Security Architecture for the Internet Protocol
- RFC 2402, IP Authentication Header (AH)
- RFC 2406, IP Encapsulating Security Payload (ESP)
- RFC 2409, The Internet Key Exchange (IKE)
- RFC-3193, Securing L2TP using IPSEC, November 2001

Description

IP Security (IPSec) is a suite of protocols that interact with one another to provide secure private communications across IP networks. These protocols allow the system to establish and maintain secure tunnels with peer security gateways. IPSec can be implemented on the system for the following applications:

- PDN Access: Subscriber IP traffic is routed over an IPSec tunnel from the system to a secure gateway on the Packet Data Network (PDN) as determined by Access Control List (ACL) criteria.
- Mobile IP: Mobile IP control signals and subscriber data is encapsulated in IPSec tunnels that are established between Foreign Agents (FAs) and Home Agents (HAs) over the Pi interfaces.

Once an IPSec tunnel is established between an FA and HA for a particular subscriber, all new Mobile IP sessions using the same FA and HA are passed over the tunnel regardless of whether or not IPSec is supported for the new subscriber sessions. Data for existing Mobile IP sessions is unaffected.

- L2TP: L2TP-encapsulated packets are routed from the system to an LNS/secure gateway over an IPSec tunnel.



Important

For more information on IPSec support, refer to the *IPSec Reference Guide*.

Traffic Policing and Rate Limiting

Allows the operator to proportion the network and support Service-level Agreements (SLAs) for customers

Description

The Traffic-Policing/Shaping feature enables configuring and enforcing bandwidth limitations on individual PDP contexts of a particular 3GPP traffic class. Values for traffic classes are defined in 3GPP TS 23.107 and are negotiated with the SGSN during PDP context activation using the values configured for the subscriber on the PDSN. Configuration and enforcement is done independently on the downlink and the uplink directions for each of the 3GPP traffic classes. Configuration is on a per-subscriber basis, but may be overridden for individual subscribers or subscriber tiers during RADIUS authentication/authorization.

A Token Bucket Algorithm (a modified trTCM, as specified in RFC2698) is used to implement the Traffic-Policing feature. The algorithm measures the following criteria when determining how to mark a packet.

- **Committed Data Rate (CDR):** The guaranteed rate (in bits per second) at which packets may be transmitted/received for the subscriber during the sampling interval.
- **Peak Data Rate (PDR):** The maximum rate (in bits per second) that packets may be transmitted/received for the subscriber during the sampling interval.
- **Burst-size:** The maximum number of bytes that may be transmitted/received for the subscriber during the sampling interval for both committed (CBS) and peak (PBS) rate conditions. This represents the maximum number of tokens that can be placed in the subscriber's "bucket". Note that the committed burst size (CBS) equals the peak burst size (PBS) for each subscriber.

Tokens are removed from the subscriber's bucket based on the size of the packets being transmitted/received. Every time a packet arrives, the system determines how many tokens need to be added (returned) to a subscriber's CBS (and PBS) bucket. This value is derived by computing the product of the time difference between incoming packets and the CDR (or PDR). The computed value is then added to the tokens remaining in the subscriber's CBS (or PBS) bucket. The total number of tokens can not be greater than the configured burst-size. If the total number of tokens is greater than the burst-size, the number is set to equal the burst-size. After passing through the Token Bucket Algorithm, the packet is internally classified with a color, as follows:

- There are not enough tokens in the PBS bucket to allow a packet to pass, then the packet is considered to be in violation and is marked "red" and the violation counter is incremented by one.
- There are enough tokens in the PBS bucket to allow a packet to pass, but not in the CBS "bucket", then the packet is considered to be in excess and is marked "yellow", the PBS bucket is decremented by the packet size, and the exceed counter is incremented by one.
- There are more tokens present in the CBS bucket than the size of the packet, then the packet is considered as conforming and is marked "green" and the CBS and PBS buckets are decremented by the packet size.

The subscriber on the PDSN can be configured with actions to take for red and yellow packets. Any of the following actions may be specified:

- **Drop:** The offending packet is discarded.
- **Transmit:** The offending packet is passed.
- **Lower the IP Precedence:** The packet's ToS octet is set to "0", thus downgrading it to Best Effort, prior to passing the packet.
- **Buffer the Packet:** The packet stored in buffer memory and transmitted to subscriber once traffic flow comes in allowed bandwidth.

Different actions may be specified for red and yellow, as well as for uplink and downlink directions and different 3GPP traffic classes.

Refer to the Intelligent Traffic Control section for additional policing and shaping capabilities of the PDSN.



Important

For more information on per subscriber traffic policing and shaping, refer to the Traffic Policing and Shaping section.

Intelligent Traffic Control

Enables operators to provide differentiated tiered service provisioning for native and non-native subscribers.

Description

Mobile carriers are looking for creative methods for maximizing network resources while, at the same time, enhancing their end users overall experience. These same mobile operators are beginning to examine solutions for providing preferential treatment for their native subscribers and services as compared to, for example, roaming subscribers, Mobile Virtual Network Operators (MVNOs) and/or Peer-to-Peer (P2P) applications. The overall end goal is to provide superior levels of performance for their customers/services, while ensuring that non-native users/applications do not overwhelm network resources.

ITC provides the ability to examine each subscriber session and respective flow(s) such that selective, configurable limits on a per-subscriber/per-flow basis can be applied. Initially, QoS in this context is defined as traffic policing on a per-subscriber/per-flow basis with the potential to manipulate Differentiated Services Code Points (DSCPs), queue redirection (i.e. move traffic to a Best Effort (BE) classification) and/or simply dropping out of profile traffic. ITC enables 5 tuple packet filters for individual application flows to be either manually configured via CLI or dynamically established via RSVP TFT information elements in 1xEV-DO Rev A or as a consequence of PDP context establishments in CDMA networks. Policy rules may be locally assigned or obtained from an external PCRF via push/pull policy signaling interactions. Policies may be applied on a per-subscriber, per-context and/or chassis-wide basis.



Important

For more information on intelligent traffic control support, refer to the *Intelligent Traffic Control* chapter.

Dynamic RADIUS Extensions (Change of Authorization)

Dynamic RADIUS extension support provide operators with greater control over subscriber PDP contexts by providing the ability to dynamically redirect data traffic, and or disconnect the PDP context.

This functionality is based on the RFC 3576, Dynamic Authorization Extensions to Remote Authentication Dial In User Service (RADIUS), July 2003 standard.

Description

The system supports the configuration and use of the following dynamic RADIUS extensions:

- **Change of Authorization:** The system supports CoA messages from the AAA server to change data filters associated with a subscriber session. The CoA request message from the AAA server must contain attributes to identify NAS and the subscriber session and a data filter ID for the data filter to apply to the subscriber session.
- **Disconnect Message:** The DM message is used to disconnect subscriber sessions in the system from a RADIUS server. The DM request message should contain necessary attributes to identify the subscriber session.

The above extensions can be used to dynamically re-direct subscriber PDP contexts to an alternate address for performing functions such as provisioning and/or account set up. This functionality is referred to as Session Redirection, or Hotlining.

Session redirection provides a means to redirect subscriber traffic to an external server by applying ACL rules to the traffic of an existing or a new subscriber session. The destination address and optionally the destination port of TCP/IP or UDP/IP packets from the subscriber are rewritten so the packet is forwarded to the designated redirected address.

Return traffic to the subscriber has the source address and port rewritten to the original values. The redirect ACL may be applied dynamically by means of the Radius Change of Authorization (CoA) extension.



Important For more information on dynamic RADIUS extensions support, refer to the *CoA, RADIUS, And Session Redirection (Hotlining)* chapter.

Features and Functionality - Inline Service Support

This section describes the features and functions of inline services supported on the PDSN. These services require additional licenses to implement the functionality.

Content Filtering

The Cisco PDSN offers two variants of network-controlled content filtering / parental control services. Each approach leverages the native DPI capabilities of the platform to detect and filter events of interest from mobile subscribers based on HTTP URL or WAP/MMS URI requests:

- **Integrated Content Filtering:** A turnkey solution featuring a policy enforcement point and category based rating database on the Cisco PDSN. An offboard AAA or PCRF provides the per-subscriber content filtering information as subscriber sessions are established. The content filtering service uses DPI to extract URL's or URI's in HTTP request messages and compares them against a static rating database to determine the category match. The provisioned policy determines whether individual subscribers are entitled to view the content.
- **Content Filtering ICAP Interface:** This solution is appropriate for mobile operators with existing installations of Active Content Filtering external servers. The service continues to harness the DPI functions of the ASR 5500 platform to extract events of interest. However in this case, the extracted requests are transferred via the Integrated Content Adaptation Protocol (ICAP) with subscriber identification information to the external ACF server which provides the category rating database and content decision functions.

Integrated Adult Content Filter

Provides a value-added service to prevent unintended viewing of objectionable content that exploits underage children. Content Filtering offers mobile operators a way to increase data ARPU and subscriber retention through a network-based solution for parental controls and content filtering. The integrated solution enables a single policy decision and enforcement point thereby streamlining the number of signaling interactions with external AAA/Policy Manager servers. When used in parallel with other services such as Enhanced Content Charging (ECS) it increases billing accuracy of charging records by insuring that mobile subscribers are only charged for visited sites they are allowed to access.

The Integrated Adult Content Filter is a subscriber-aware inline service provisioned on an ASR 5500 running PDSN services. Integrated Content Filtering utilizes the local DPI engine and harnesses a distributed software architecture that scales with the number of active PDSN sessions on the system.

Content Filtering policy enforcement is the process of deciding if a subscriber should be able to receive some content. Typical options are to allow, block, or replace/redirect the content based on the rating of the content and the policy defined for that content and subscriber. The policy definition is transferred in an authentication response from a AAA server or Diameter policy message via the Gx reference interface from an adjunct

PCRF. The policy is applied to subscribers through rulebase or APN/Subscriber configuration. The policy determines the action to be taken on the content request on the basis of its category. A maximum of one policy can be associated with a rulebase.

ICAP Interface

Provides a value-added service to prevent unintended viewing of objectionable content that exploits underage children. Content Filtering offers mobile operators a way to increase data ARPU and subscriber retention through a network-based solution for parental controls and content filtering. The Content Filtering ICAP solution is appropriate for operators with existing installations of Active Content Filtering servers in their networks.

The Enhanced Charging Service (ECS) provides a streamlined Internet Content Adaptation Protocol (ICAP) interface to leverage the Deep Packet Inspection (DPI) to enable external Application Servers to provide their services without performing the DPI functionality and without being inserted in the data flow. The ICAP interface may be attractive to mobile operators that prefer to use an external Active Content Filtering (ACF) Platform. If a subscriber initiates a WAP (WAP1.x or WAP2.0) or Web session, the subsequent GET/POST request is detected by the deep packet inspection function. The URL of the GET/POST request is extracted by the local DPI engine on the ASR 5500 platform and passed, along with subscriber identification information and the subscriber request, in an ICAP message to the Application Server (AS). The AS checks the URL on the basis of its category and other classifications like, type, access level, content category and decides if the request should be authorized, blocked or redirected by answering the GET/POST message. Depending upon the response received from the ACF server, the PDSN either passes the request unmodified or discards the message and responds to the subscriber with the appropriate redirection or block message.

Network Address Translation (NAT)

NAT translates non-routable private IP address(es) to routable public IP address(es) from a pool of public IP addresses that have been designated for NAT. This enables to conserve on the number of public IP addresses required to communicate with external networks, and ensures security as the IP address scheme for the internal network is masked from external hosts, and each outgoing and incoming packet goes through the translation process.

NAT works by inspecting both incoming and outgoing IP datagrams and, as needed, modifying the source IP address and port number in the IP header to reflect the configured NAT address mapping for outgoing datagrams. The reverse NAT translation is applied to incoming datagrams.

NAT can be used to perform address translation for simple IP and mobile IP. NAT can be selectively applied/denied to different flows (5-tuple connections) originating from subscribers based on the flows' L3/L4 characteristics—Source-IP, Source-Port, Destination-IP, Destination-Port, and Protocol.

NAT supports the following mappings:

- One-to-One
- Many-to-One



Important

For more information on NAT, refer to the *Network Address Translation Administration Guide*.

Peer-to-Peer Detection

Allows operators to identify P2P traffic in the network and applying appropriate controlling functions to ensure fair distribution of bandwidth to all subscribers.

Peer-to-Peer (P2P) is a term used in two slightly different contexts. At a functional level, it means protocols that interact in a peering manner, in contrast to client-server manner. There is no clear differentiation between the function of one node or another. Any node can function as a client, a server, or both—a protocol may not clearly differentiate between the two. For example, peering exchanges may simultaneously include client and server functionality, sending and receiving information.

Detecting peer-to-peer protocols requires recognizing, in real time, some uniquely identifying characteristic of the protocols. Typical packet classification only requires information uniquely typed in the packet header of packets of the stream(s) running the particular protocol to be identified. In fact, many peer-to-peer protocols can be detected by simple packet header inspection. However, some P2P protocols are different, preventing detection in the traditional manner. This is designed into some P2P protocols to purposely avoid detection. The creators of these protocols purposely do not publish specifications. A small class of P2P protocols is stealthier and more challenging to detect. For some protocols no set of fixed markers can be identified with confidence as unique to the protocol.

Operators care about P2P traffic because of the behavior of some P2P applications (for example, Bittorrent, Skype, and eDonkey). Most P2P applications can hog the network bandwidth such that 20 P2P users can generate as much as traffic generated by the rest 80% non-P2P users. This can result into a situation where non-P2P users may not get enough network bandwidth for their legitimate use because of excess usage of bandwidth by the P2P users. Network operators need to have dynamic network bandwidth / traffic management functions in place to ensure fair distributions of the network bandwidth among all the users. And this would include identifying P2P traffic in the network and applying appropriate controlling functions to the same (for example, content-based premium billing, QoS modifications, and other similar treatments).

Cisco's P2P detection technology makes use of innovative and highly accurate protocol behavioral detection techniques.



Important

For more information on peer-to-peer detection, refer to the *Application Detection and Control Administration Guide*.

Personal Stateful Firewall

The Personal Stateful Firewall is an in-line service feature that inspects subscriber traffic and performs IP session-based access control of individual subscriber sessions to protect the subscribers from malicious security attacks.

The Personal Stateful Firewall supports stateless and stateful inspection and filtering based on the configuration.

In stateless inspection, the firewall inspects a packet to determine the 5-tuple—source and destination IP addresses and ports, and protocol—information contained in the packet. This static information is then compared against configurable rules to determine whether to allow or drop the packet. In stateless inspection the firewall examines each packet individually, it is unaware of the packets that have passed through before it, and has no way of knowing if any given packet is part of an existing connection, is trying to establish a new connection, or is a rogue packet.

In stateful inspection, the firewall not only inspects packets up through the application layer / layer 7 determining a packet's header information and data content, but also monitors and keeps track of the connection's state.

For all active connections traversing the firewall, the state information, which may include IP addresses and ports involved, the sequence numbers and acknowledgement numbers of the packets traversing the connection, TCP packet flags, etc. is maintained in a state table. Filtering decisions are based not only on rules but also on the connection state established by prior packets on that connection. This enables to prevent a variety of DoS, DDoS, and other security violations. Once a connection is torn down, or is timed out, its entry in the state table is discarded.

The Enhanced Charging Service (ECS) / Active Charging Service (ACS) in-line service is the primary vehicle that performs packet inspection and charging. For more information on ECS, see the *Enhanced Charging Service Administration Guide*.

**Important**

For more information on Personal Stateful Firewall, refer to the *Personal Stateful Firewall Administration Guide*.

Features and Functionality - External Application Support

This section describes the features and functions of external applications supported on the PDSN. These services require additional licenses to implement the functionality.

Mobility Unified Reporting

The Cisco Mobility Unified Reporting (MUR)/Mobility Unified Reporting and Analytics (MURAL) system is a Web-based application providing a unified reporting interface for diverse data from Cisco Systems In-line service and storage applications.

The MUR/MURAL application provides comprehensive and consistent set of statistics and customized reports, report scheduling and distribution from ASR chassis / in-line service product. For example, a subscriber's Quality of Experience, top 10 sites visited, top 10 users, and so on.

The MUR/MURAL application provides reporting capability for Content Filtering (CF) data, bulk statistics, Key Performance Indicators (KPIs), EDRs data from in-line service and storage applications. The MUR/MURAL application facilitates and enhances the operators' ability to simply and easily determine the health and usage of the network.

**Important**

For more information on MUR support, refer to the *MUR Installation and Administration Guide*.

For more information on MURAL support, refer to the *MURAL Installation and Administration Guide* and *MURAL User Guide*.

CDMA2000 Data Network Deployment Configurations

This section provides examples of how the system can be deployed within a wireless carrier's network. As noted previously in this chapter, the system can be deployed in standalone configurations, serving as a Packet Data Serving Node/Foreign Agent (PDSN/FA), a Home Agent (HA), or in a combined PDSN/FA/HA configuration providing all services from a single chassis. Although XT-2 systems are highly flexible, but

XT-2 systems are pre-loaded with purchased services and operator can not add additional services through license. Operator needs to predefine the services required on a system.

Standalone PDSN/FA and HA Deployments

The PDSN/FA serves as an integral part of a CDMA2000 network by providing the packet processing and re-direction to the mobile user's home network through communications with the HA. In cases where the mobile user connects to a PDSN that serves their home network, no re-direction is required.

The following figure depicts a sample network configuration wherein the PDSN/FA and HA are separate systems.

Figure 1: PDSN/FA and HA Network Deployment Configuration Example

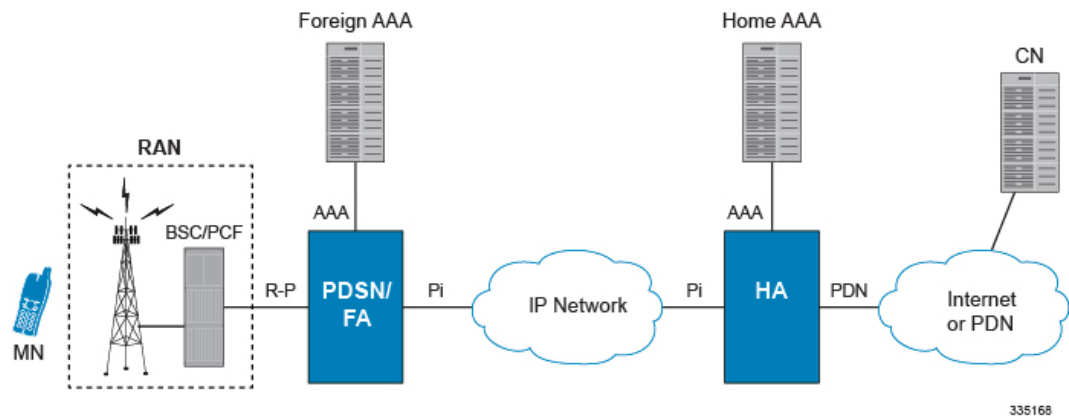

The HA allows mobile nodes to be reached, or served, by their home network through its home address even when the mobile node is not attached to its home network. The HA performs this function through interaction with an FA that the mobile node is communicating with using the Mobile IP protocol. Such transactions are performed through the use of virtual private networks that create Mobile IP tunnels between the HA and FA.

Interface Descriptions

This section describes the primary interfaces used in a CDMA2000 wireless data network deployment.

R-P Interface

This interface exists between the Packet Control Function (PCF) and the PDSN/FA and implements the A10 and A11 (data and bearer signaling respectively) protocols defined in 3GPP2 specifications.

This interface exists between the Packet Control Function (PCF) and the PDSN/FA and implements either the A10 and A11 (data and bearer signaling respectively) protocols defined in 3GPP2 specifications or the proprietary Closed R-P protocol from Nortel Networks®. The Closed R-P protocol encapsulates PPP packets using an enhanced version of the Layer 2 Tunneling Protocol (L2TP) between the PCF and the Packet Data Serving Node (PDSN).



Important

A valid feature use key is required to be installed before the Closed R-P protocol may be used. For more information on obtaining this feature key, please contact your sales representative.

The PCF can be co-located with the Base Station Controller (BSC) as part of the Radio Access Node (RAN). The PDSN/FA is connected to the RAN via Ethernet ports. These ports also support outbound IP traffic that carries user data to the HA for Mobile IP services, or to the Internet or Wireless Access Protocol (WAP) gateway for Simple IP services.

Pi Interfaces

The Pi interface provides connectivity between the HA and its corresponding FA. The Pi interface is used to establish a Mobile IP tunnels between the PDSN/FA and HA.

PDN Interfaces

PDN interface provide connectivity between the PDSN and/or HA to packet data networks such as the Internet or a corporate intranet.

AAA Interfaces

Using the LAN ports located on the Switch Processor I/O (SPIO) and Ethernet line cards, these interfaces carry AAA messages to and from RADIUS accounting and authentication servers. The SPIO supports RADIUS-capable management interfaces using either copper or fiber Ethernet connectivity through two auto-sensing 10/100/1000 Mbps Ethernet interfaces or two SFP optical gigabit Ethernet interfaces. User-based RADIUS messaging is transported using the Ethernet line cards.

While most carriers will configure separate AAA interfaces to allow for out-of-band RADIUS messaging for system administrative users and other operations personnel, it is possible to use a single AAA interface hosted on the Ethernet line cards to support a single RADIUS server that supports both management users and network users.



Important

Subscriber AAA interfaces should always be configured using Ethernet line card interfaces for the highest performance. The out-of-band local context should not be used for service subscriber AAA functions.

Co-Located Deployments

An advantage of the system is its ability to support both high-density PDSN/FA and HA configurations within the same chassis. The economies of scale presented in this configuration example provide for both improved session handling and reduced cost in deploying a CDMA2000 data network.

The following figure depicts a sample co-located deployment.

Figure 2: Co-located PDSN/FA and HA Configuration Example

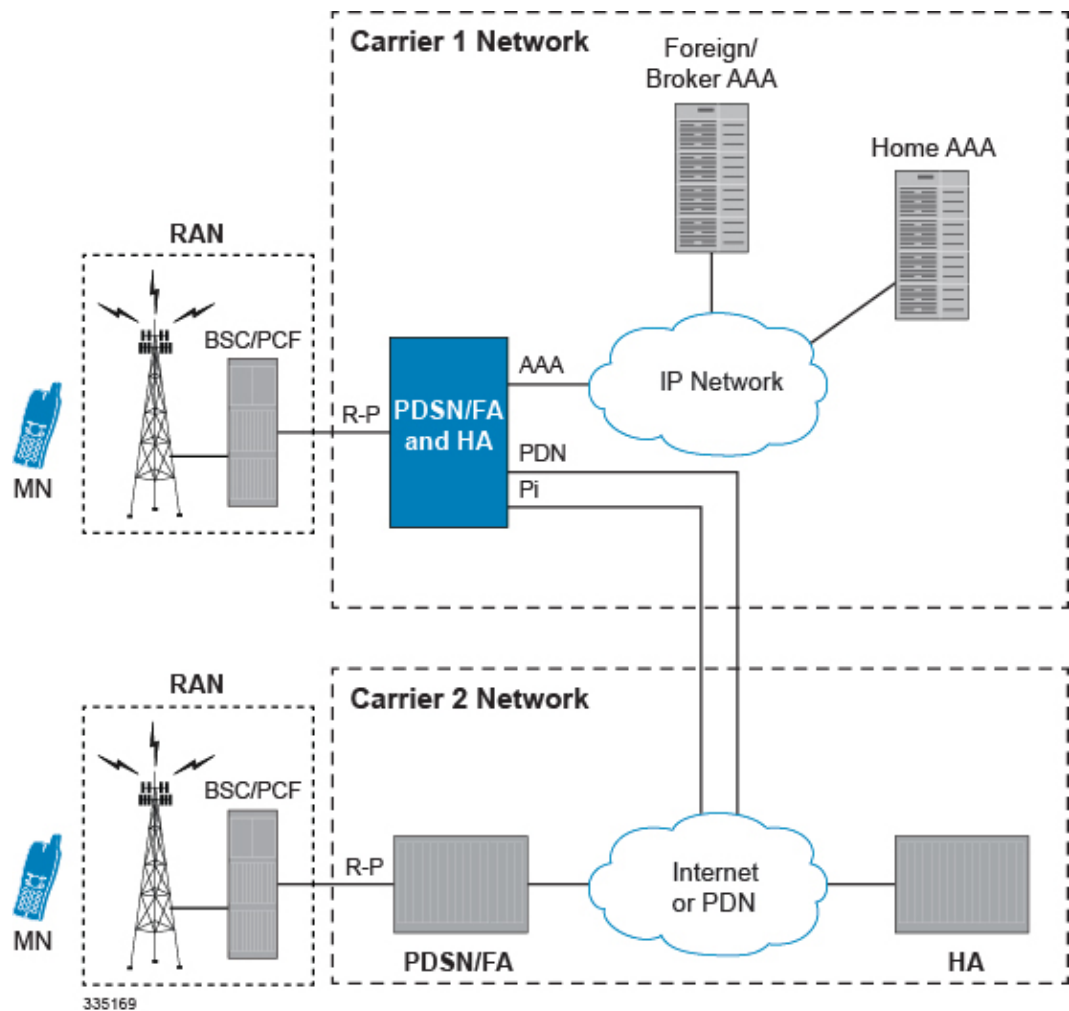

It should be noted that all interfaces defined within the 3GPP2 standards for 1x deployments exist in this configuration as they are described in the two previous sections. This configuration can support communications to external, or standalone, PDSNs/FAs and/or HAs using all prescribed standards.

Understanding Simple IP and Mobile IP

From a mobile subscriber's perspective, packet data services are delivered from the service provider network using two access methods:

- Local and public network access
- Private network access

Within the packet data network, access is similar to accessing the public Internet through any other access device. In a private network access scenario, the user must be tunneled into the private network after initial authentication has been performed.

These two methods are provided using one of the following access applications:

- **Simple IP:** The mobile user is dynamically assigned an IP address from the service provider. The user can maintain this address within a defined geographical area, but when the user moves outside of this area, their IP address will be lost. This means that whenever a mobile user moves to a new location, they will need to re-register with the service provider to obtain a new IP address.
- **Mobile IP:** The mobile subscriber uses either a static or dynamically assigned IP address that belongs to their home network. As the subscriber roams through the network, the IP address is maintained providing the subscriber with the opportunity to use IP applications that require seamless mobility such as performing file transfers.
- **Proxy Mobile IP:** Provides a mobility solution for subscribers whose Mobile Nodes (MNs) do not support the Mobile IP protocol. The PDSN/FA proxy the Mobile IP tunnel with the HA on behalf of the MS. The subscriber receives an IP address from either the service provider or from their home network. As the subscriber roams through the network, the IP address is maintained providing the subscriber with the opportunity to use IP applications that require seamless mobility such as transferring files.

The following sections outline both Simple IP, Mobile IP, and Proxy Mobile IP and how they work in a 3G network.

Simple IP

From a packet data perspective, Simple IP is similar to how a dial-up user would connect to the Internet using the Point-to-Point Protocol (PPP) and the Internet Protocol (IP) through an Internet Service Provider (ISP). With Simple IP, the mobile user is assigned a dynamic IP address from a PDSN or AAA server that is serving them locally (a specific geographic area). Once the mobile user is connected to the particular radio network that the assigning PDSN belongs to, an IP address is assigned to the mobile node. The PDSN provides IP routing services to the registered mobile user through the wireless service provider's network.

There is no mobility beyond the PDSN that assigns the dynamic IP address to the mobile user, which means that should the mobile user leave the geographic area where service was established (moves to a new radio network service area), they will need to obtain a new IP address with a new PDSN that is serving the new area. This new connection may or may not be provided by the same service provider.

How Simple IP Works

As described earlier, Simple IP uses two basic communications protocols, PPP and IP. The following figure depicts where each of these protocols are used in a Simple IP call.

Figure 3: Simple IP Protocol Usage

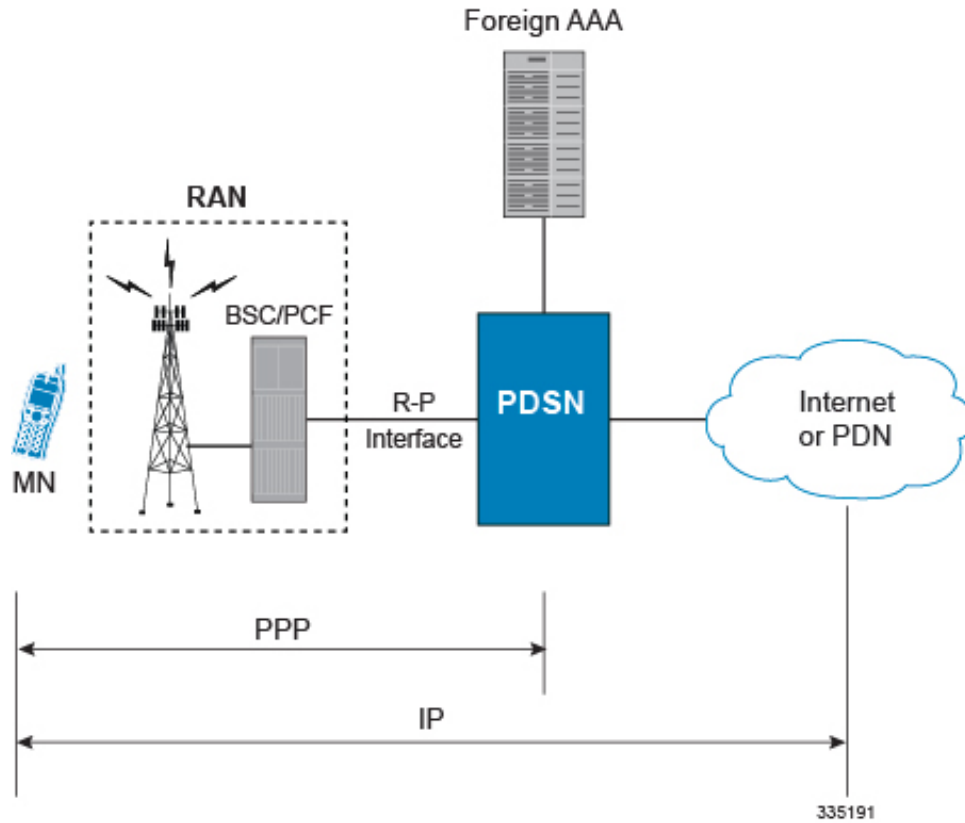

As depicted in the figure above, PPP is used to establish a communications session between the MN and the PDSN. Once a PPP session is established, the Mobile Node (MN) and end host communicate using IP packets.

The following figure and table provides a high-level view of the steps required to make a Simple IP call that is initiated by the MN to an end host. Users should keep in mind that steps 2, 3, 11, and 12 in the call flow are related to the Radio Access Node (RAN) functions and are intended to show a high-level overview of radio communications iterations, and as such are outside the scope of packet-based communications presented here.

Figure 4: Simple IP Call Flow

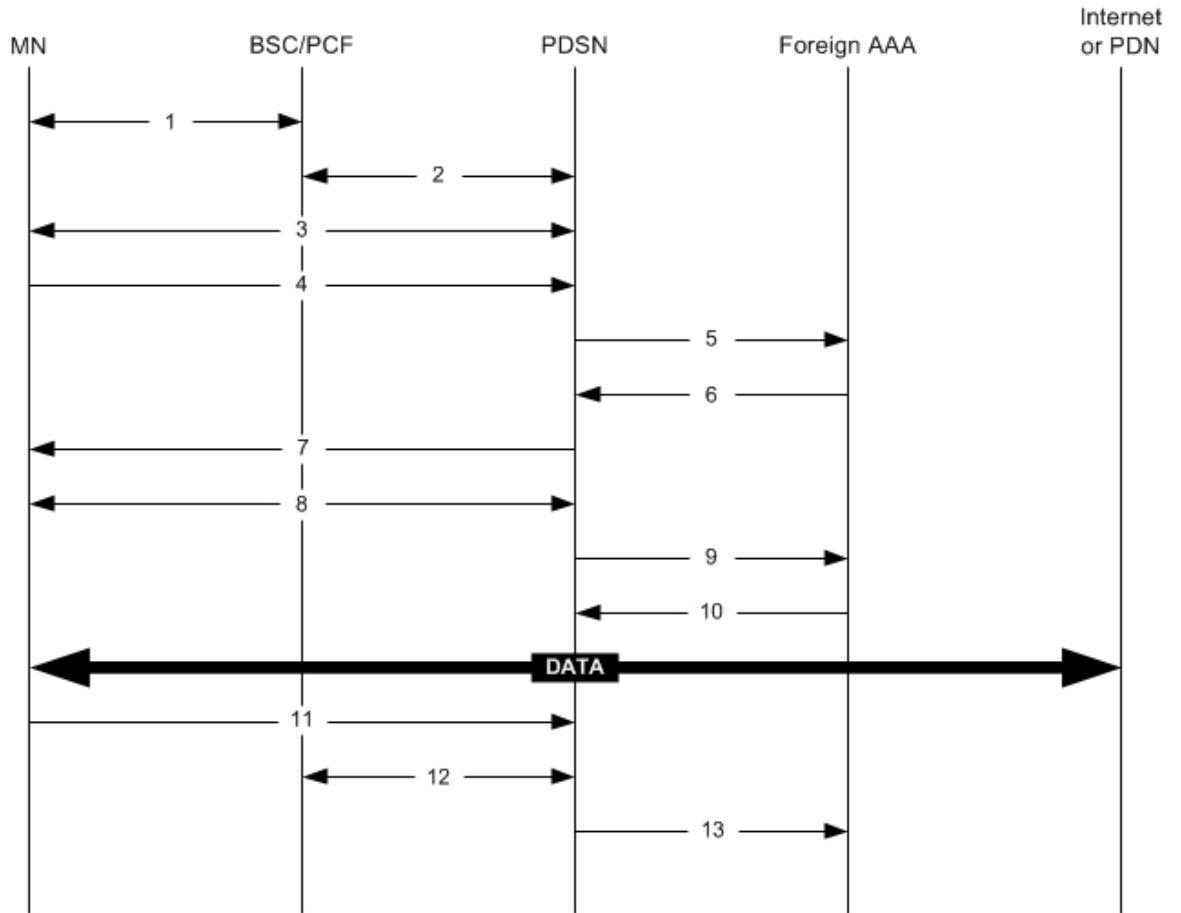

335192

Table 1: Simple IP Call Flow Description

Step	Description
1	Mobile Node (MN) secures a traffic channel over the airlink with the RAN through the BSC/PCF.
2	The PCF and PDSN establish the R-P interface for the session.
3	The PDSN and MN negotiate Link Control Protocol (LCP).
4	Upon successful LCP negotiation, the MN sends a PPP Authentication Request message to the PDSN.
5	The PDSN sends an Access Request message to the RADIUS AAA server.

Step	Description
6	The RADIUS AAA server successfully authenticates the subscriber and returns an Access Accept message to the PDSN. The Accept message may contain various attributes to be assigned to the MN.
7	The PDSN sends a PPP Authentication Response message to the MN.
8	The MN and the PDSN negotiate the Internet Protocol Control Protocol (IPCP) that results in the MN receiving an IP address.
9	The PDSN forwards a RADIUS Accounting Start message to the AAA server fully establishing the session allowing the MN to send/receive data to/from the PDN.
10	Upon completion of the session, the MN sends an LCP Terminate Request message to the PDSN to end the PPP session.
11	The BSC closes the radio link while the PCF closes the R-P session between it and the PDSN. All PDSN resources used to facilitate the session are reclaimed (IP address, memory, etc.).
12	The PDSN sends accounting stop record to the AAA server, ending the session.

Mobile IP

Mobile IP provides a network-layer solution that allows mobile nodes (MNs, i.e. mobile phones, wireless PDAs, and other mobile devices) to receive routed IP packets from their home network while they are connected to any visitor network using their permanent or home IP address. Mobile IP allows mobility in a dynamic method that allows nodes to maintain ongoing communications while changing links as the user traverses the global Internet from various locations outside their home network.

In Mobile IP, the Mobile Node (MN) receives an IP address, either static or dynamic, called the "home address" assigned by its Home Agent (HA). A distinct advantage with Mobile IP is that MNs can hand off between different radio networks that are served by different PDSNs.

In this scenario, the PDSN in the visitor network performs as a Foreign Agent (FA), establishing a virtual session with the MN's HA. Each time the MN registers with a different PDSN/FA, the FA assigns the MN a care-of-address. Packets are then encapsulated into IP tunnels and transported between FA, HA, and the MN.

Mobile IP Tunneling Methods

Tunneling by itself is a technology that enables one network to send its data via another network's connections. Tunneling works by encapsulating a network protocol within a packet, carried by the second network. Tunneling is also called encapsulation. Service providers typically use tunneling for two purposes first, to transport otherwise un-routable packets across the IP network and second, to provide data separation for Virtual Private Networking (VPN) services. In Mobile IP, tunnels are used to transport data packets between the FA and HA.

The system supports the following tunneling protocols, as defined in the IS-835-A specification and the relevant Request For Comments (RFCs) for Mobile IP:

IP in IP tunnels

IP in IP tunnels basically encapsulate one IP packet within another using a simple encapsulation technique. To encapsulate an IP datagram using IP in IP encapsulation, an outer IP header is inserted before the datagram's existing IP header. Between them are other headers for the path, such as security headers specific to the tunnel configuration. Each header chains to the next using IP Protocol values. The outer IP header Source and Destination identify the "endpoints" of the tunnel. The inner IP header Source and Destination identify the original sender and recipient of the datagram, while the inner IP header is not changed by the encapsulator, except to decrement the TTL, and remains unchanged during its delivery to the tunnel exit point. No change to IP options in the inner header occurs during delivery of the encapsulated datagram through the tunnel. If needed, other protocol headers such as the IP Authentication header may be inserted between the outer IP header and the inner IP header.

The Mobile IP working group has specified the use of encapsulation as a way to deliver datagrams from an MN's HA to an FA, and conversely from an FA to an HA, that can deliver the data locally to the MN at its current location.

GRE tunnels

The Generic Routing Encapsulation (GRE) protocol performs encapsulation of IP packets for transport across disparate networks. One advantage of GRE over earlier tunneling protocols is that any transport protocol can be encapsulated in GRE. GRE is a simple, low overhead approach—the GRE protocol itself can be expressed in as few as eight octets as there is no authentication or tunnel configuration parameter negotiation. GRE is also known as IP Protocol 47.



Important

The chassis simultaneously supports GRE protocols with key in accordance with RFC-1701/RFC-2784 and "Legacy" GRE protocols without key in accordance to RFC-2002.

Another advantage of GRE tunneling over IP-in-IP tunneling is that GRE tunneling can be used even when conflicting addresses are in use across multiple contexts (for the tunneled data).

Communications between the FA and HA can be done in either the forward or reverse direction using the above protocols. Additionally, another method of routing information between the FA and various content servers used by the HA exists. This method is called Triangular Routing. Each of these methods is explained below.

Forward Tunneling

In the wireless IP world, forward tunneling is a tunnel that transports packets from the packet data network towards the MN. It starts at the HA and ends at the MN's care-of address. Tunnels can be as simple as IP-in-IP tunnels, GRE tunnels, or even IP Security (IPSec) tunnels with encryption. These tunnels can be started automatically, and are selected based on the subscriber's user profile.

Reverse Tunneling

A reverse tunnel starts at the MN's care-of address, which is the FA, and terminates at the HA.

When an MN arrives at a foreign network, it listens for agent advertisements and selects an FA that supports reverse tunnels. The MN requests this service when it registers through the selected FA. At this time, the MN may also specify a delivery technique such as Direct or the Encapsulating Delivery Style.

Using the Direct Delivery Style, which is the default mode for the system, the MN designates the FA as its default router and sends packets directly to the FA without encapsulation. The FA intercepts them, and tunnels them to the HA.

Using the Encapsulating Delivery Style, the MN encapsulates all its outgoing packets to the FA. The FA then de-encapsulates and re-tunnels them to the HA, using the FA's care-of address as the entry-point for this new tunnel.

Following are some of the advantages of reverse tunneling:

- All datagrams from the mobile node seem to originate from its home network
- The FA can keep track of the HA that the mobile node is registered to and tunnel all datagrams from the mobile node to its HA

Triangular Routing

Triangular routing is the path followed by a packet from the MN to the Correspondent Node (CN) via the FA. In this routing scenario, the HA receives all the packets destined to the MN from the CN and redirects them to the MN's care-of-address by forward tunneling. In this case, the MN sends packets to the FA, which are transported using conventional IP routing methods.

A key advantage of triangular routing is that reverse tunneling is not required, eliminating the need to encapsulate and de-capsulate packets a second time during a Mobile IP session since only a forward tunnel exists between the HA and PDSN/FA.

A disadvantage of using triangular routing is that the HA is unaware of all user traffic for billing purposes. Also, both the HA and FA are required to be connected to a private network. This can be especially troublesome in large networks, serving numerous enterprise customers, as each FA would have to be connected to each private network.

The following figure shows an example of how triangular routing is performed.

Figure 5: Mobile IP, FA and HA Tunneling/Transport Methods

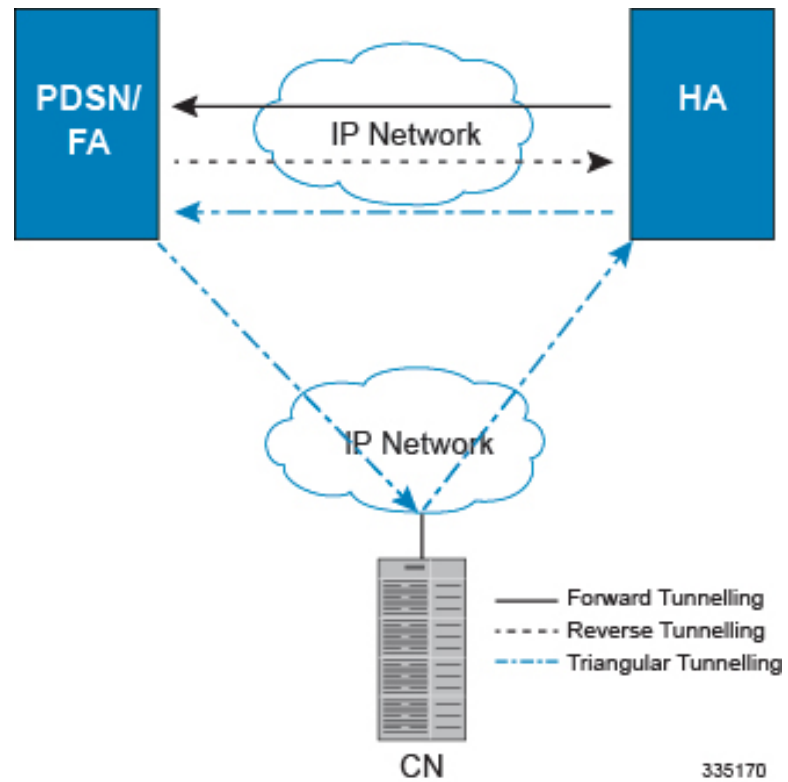

How Mobile IP Works

As described earlier, Mobile IP uses three basic communications protocols PPP, IP, and Tunneled IP in the form of IP-in-IP or GRE tunnels. The following figure depicts where each of these protocols are used in a basic Mobile IP call.

Figure 6: Mobile IP Protocol Usage

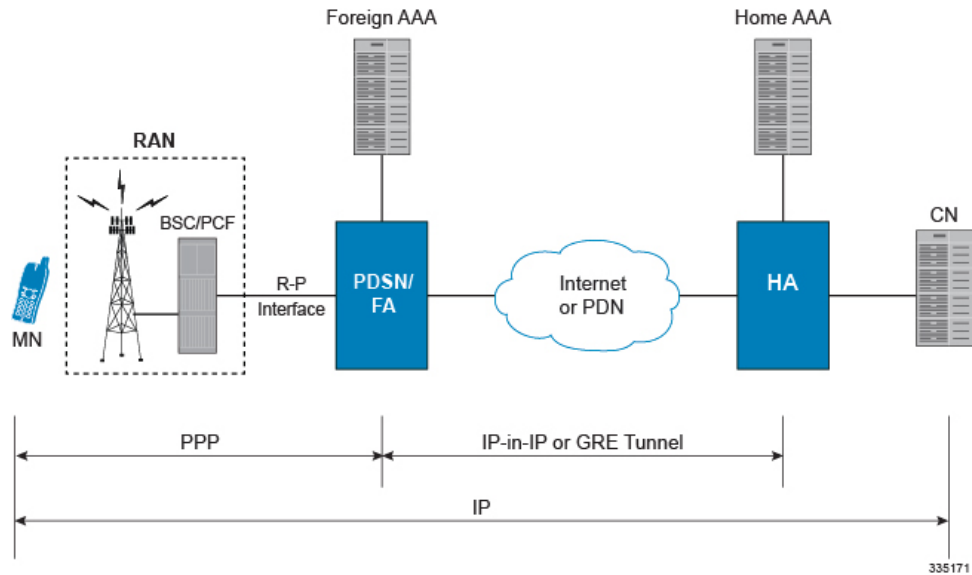

As depicted in the figure above, PPP is used to establish a communications session between the MN and the FA. Once a PPP session is established, the MN can communicate with the HA, using the FA as a mediator or broker. Data transport between the FA and HA use tunneled IP, either IP-in-IP or GRE tunneling. Communication between the HA and End Host can be achieved using the Internet or a private IP network and can use any IP protocol.

The following figure provides a high-level view of the steps required to make a Mobile IP call that is initiated by the MN to a HA and table that follows, explains each step in detail. Users should keep in mind that steps in the call flow related to the Radio Access Node (RAN) functions are intended to show a high-level overview of radio communications iterations, and as such are outside the scope of packet-based communications presented here.

Figure 7: Mobile IP Call Flow

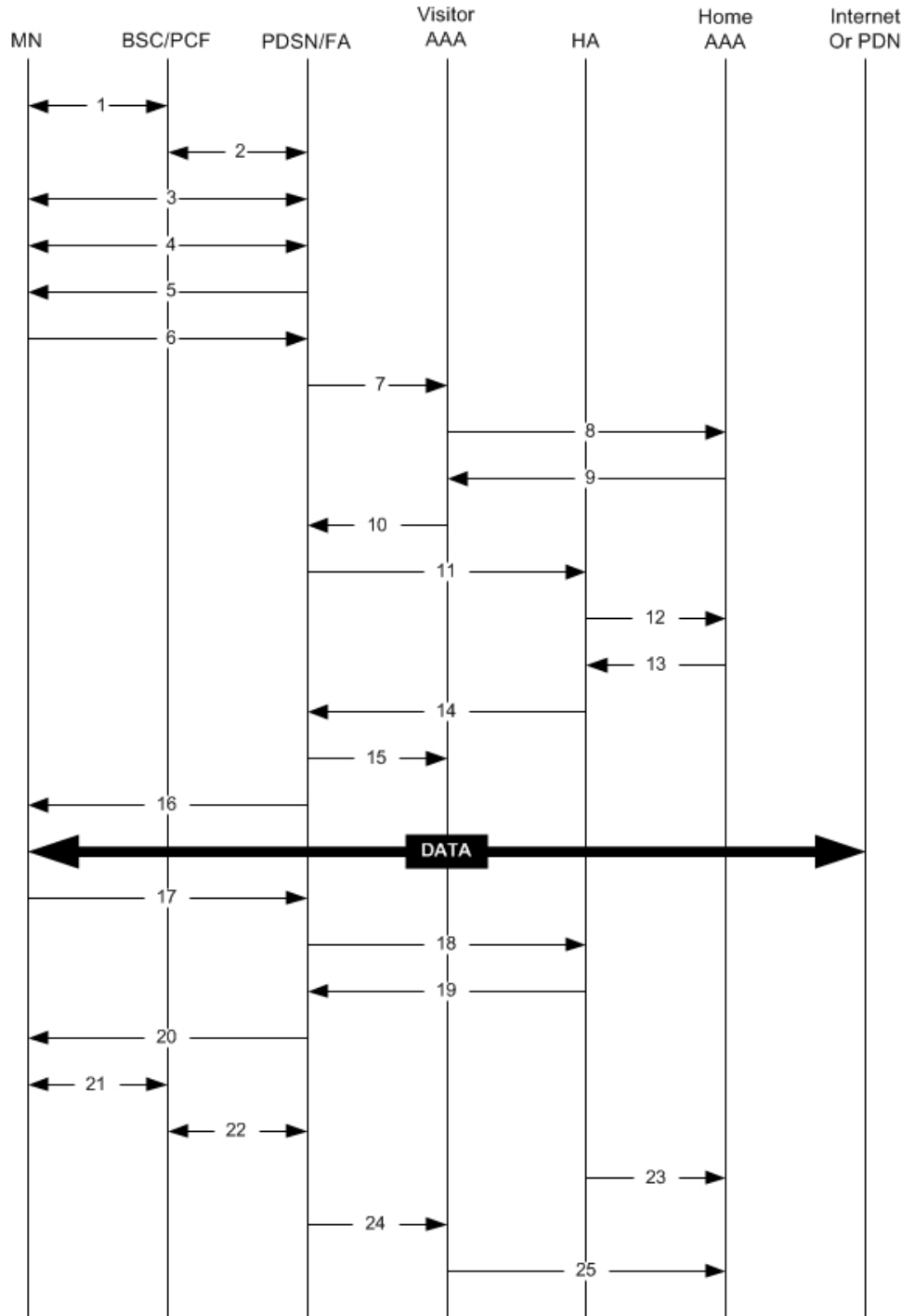

335172

Table 2: Mobile IP Call Flow Description

Step	Description
1	Mobile Node (MN) secures a traffic channel over the airlink with the RAN through the BSC/PCF.
2	The PCF and PDSN establish the R-P interface for the session.
3	The PDSN and MN negotiate Link Control Protocol (LCP).
4	The PDSN and MN negotiate the Internet Protocol Control Protocol (IPCP).
5	The PDSN/FA sends an Agent Advertisement to the MN.
6	The MN sends a Mobile IP Registration Request to the PDSN/FA.
7	The PDSN/FA sends an Access Request message to the visitor AAA server.
8	The visitor AAA server proxies the request to the appropriate home AAA server.
9	The home AAA server sends an Access Accept message to the visitor AAA server.
10	The visitor AAA server forwards the response to the PDSN/FA.
11	Upon receipt of the response, the PDSN/FA forwards a Mobile IP Registration Request to the appropriate HA.
12	The HA sends an Access Request message to the home AAA server to authenticate the MN/subscriber.
13	The home AAA server returns an Access Accept message to the HA.
14	Upon receiving response from home AAA, the HA sends a reply to the PDSN/FA establishing a forward tunnel. Note that the reply includes a Home Address (an IP address) for the MN.
15	The PDSN/FA sends an Accounting Start message to the visitor AAA server. The visitor AAA server proxies messages to the home AAA server as needed.
16	The PDSN return a Mobile IP Registration Reply to the MN establishing the session allowing the MN to send/receive data to/from the PDN.

Step	Description
17	Upon session completion, the MN sends a Registration Request message to the PDSN/FA with a requested lifetime of 0.
18	The PDSN/FA forwards the request to the HA.
19	The HA sends a Registration Reply to the PDSN/FA accepting the request.
20	The PDSN/FA forwards the response to the MN.
21	The MN and PDSN/FA negotiate the termination of LCP effectively ending the PPP session.
22	The PCF and PDSN/FA close terminate the R-P session.
23	The HA sends an Accounting Stop message to the home AAA server.
24	The PDSN/FA sends an Accounting Stop message to the visitor AAA server.
25	The visitor AAA server proxies the accounting data to the home AAA server.

Proxy Mobile IP

Proxy Mobile IP provides mobility for subscribers with MNs that do not support the Mobile IP protocol stack.

For subscriber sessions using Proxy Mobile IP, R-P and PPP sessions get established as they would for a Simple IP session. However, the PDSN/FA performs Mobile IP operations with an HA (identified by information stored in the subscriber's profile) on behalf of the MN while the MN performs only Simple IP processes. The protocol details are similar to those displayed in figure earlier for Mobile IP.

The MN is assigned an IP address by either the PDSN/FA or the HA. Regardless of its source, the address is stored in a Mobile Binding Record (MBR) stored on the HA. Therefore, as the MN roams through the service provider's network, each time a hand-off occurs, the MN will receive the same IP address stored in the MBR on the HA.

Note that unlike Mobile IP-capable MNs that can perform multiple sessions over a single PPP link, Proxy Mobile IP allows only a single session over the PPP link. In addition, simultaneous Mobile and Simple IP sessions will not be supported for an MN by an FA currently facilitating a Proxy Mobile IP session for the MN.

How Proxy Mobile IP Works

This section contains call flows displaying successful Proxy Mobile IP session setup scenarios. Two scenarios are described based on how the MN receives an IP address:

- **Scenario 1:** The AAA server specifies an IP address that the PDSN allocates to the MN from one of its locally configured static pools.
- **Scenario 2:** The HA assigns an IP address to the MN from one of its locally configured dynamic pools.

Scenario 1: AAA server and PDSN/FA Allocate IP Address

The following figure and table display and describe a call flow in which the MN receives its IP address from the AAA server and PDSN/FA.

Figure 8: AAA/PDSN Assigned IP Address Proxy Mobile IP Call Flow

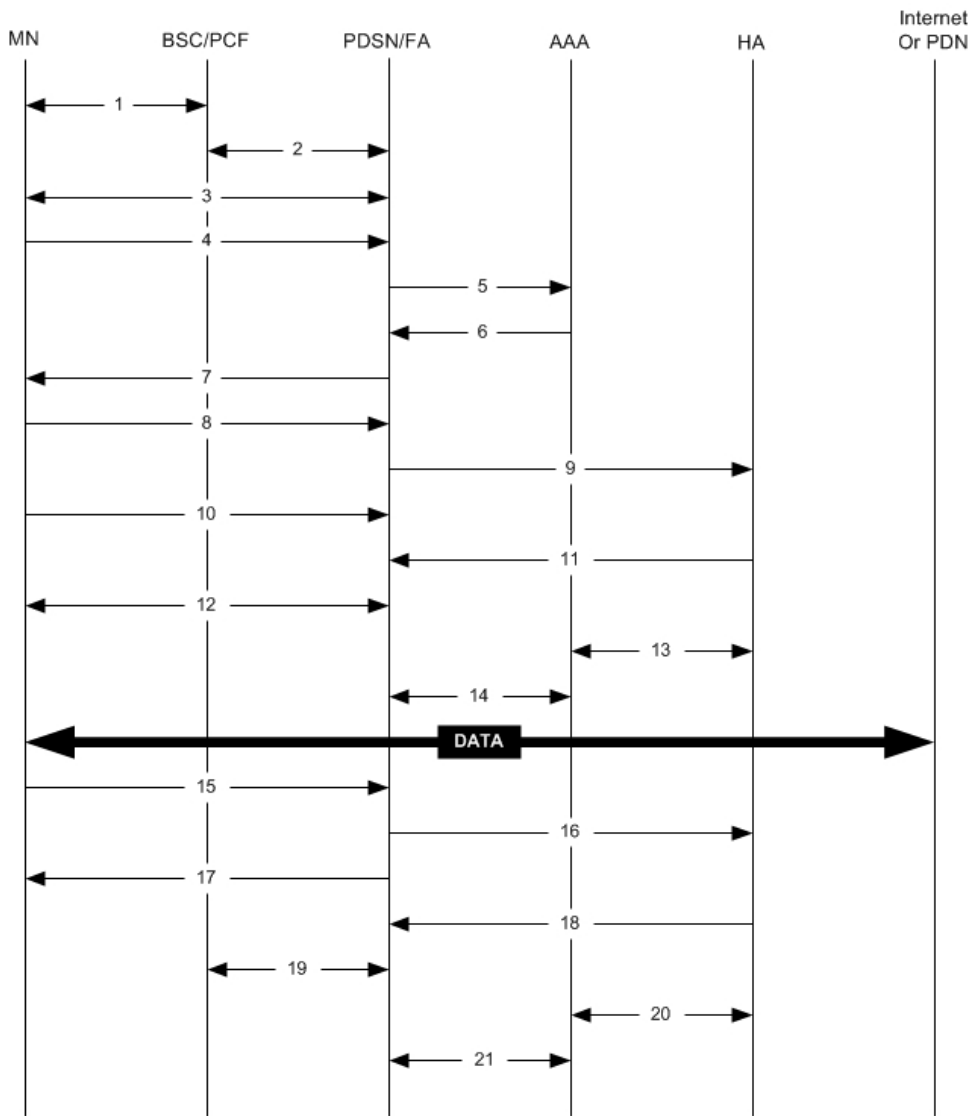

335164

Table 3: AAA/PDSN Assigned IP Address Proxy Mobile IP Call Flow Description

Step	Description
1	Mobile Node (MN) secures a traffic channel over the airlink with the RAN through the BSC/PCF.
2	The PCF and PDSN/FA establish the R-P interface for the session.

Step	Description
3	The PDSN/FA and MN negotiate Link Control Protocol (LCP).
4	Upon successful LCP negotiation, the MN sends a PPP Authentication Request message to the PDSN/FA.
5	The PDSN/FA sends an Access Request message to the RADIUS AAA server.
6	The RADIUS AAA server successfully authenticates the subscriber and returns an Access Accept message to the PDSN/FA. The Accept message may contain various attributes to be assigned to the MN including the MN's Home Address (IP address) and the IP address of the HA to use.
7	The PDSN/FA sends a PPP Authentication Response message to the MN.
8	The MN sends an Internet Protocol Control Protocol (IPCP) Configuration Request message to the PDSN/FA with an MN address of 0.0.0.0.
9	The PDSN/FA forwards a Proxy Mobile IP Registration Request message to the HA. The message includes such things as the MN's home address, the IP address of the FA (the care-of-address), and the FA-HA extension (security parameter index (SPI)).
10	While the FA is communicating with the HA, the MN may send additional IPCP Configuration Request messages.
11	The HA responds with a Proxy Mobile IP Registration Response after validating the home address against its pool(s). The HA also creates a Mobile Binding Record (MBR) for the subscriber session.
12	The MN and the PDSN/FA negotiate IPCP. The result is that the MN is assigned the home address originally specified by the AAA server.
13	While the MN and PDSN/FA are negotiating IPCP, the HA and AAA server initiate accounting.
14	Upon completion of the IPCP negotiation, the PDSN/FA and AAA server initiate accounting fully establishing the session allowing the MN to send/receive data to/from the PDN.
15	Upon completion of the session, the MN sends an LCP Terminate Request message to the PDSN to end the PPP session.

Scenario 2: HA Assigns IP Address to MN from Locally Configured Dynamic Pools

Step	Description
16	The PDSN/FA sends a Proxy Mobile IP De-registration Request message to the HA.
17	The PDSN/FA send an LCP Terminate Acknowledge message to the MN ending the PPP session.
18	The HA sends a Proxy Mobile IP De-Registration Response message to the FA terminating the Pi interface
19	The PDSN/FA and the PCF terminate the R-P session.
20	The HA and the AAA server stop accounting for the session.
21	The PDSN and the AAA server stop accounting for the session.

Scenario 2: HA Assigns IP Address to MN from Locally Configured Dynamic Pools

The following figure and table display and describe a call flow in which the MN receives its IP address from the AAA server and PDSN/FA.

Figure 9: HA Assigned IP Address Proxy Mobile IP Call Flow

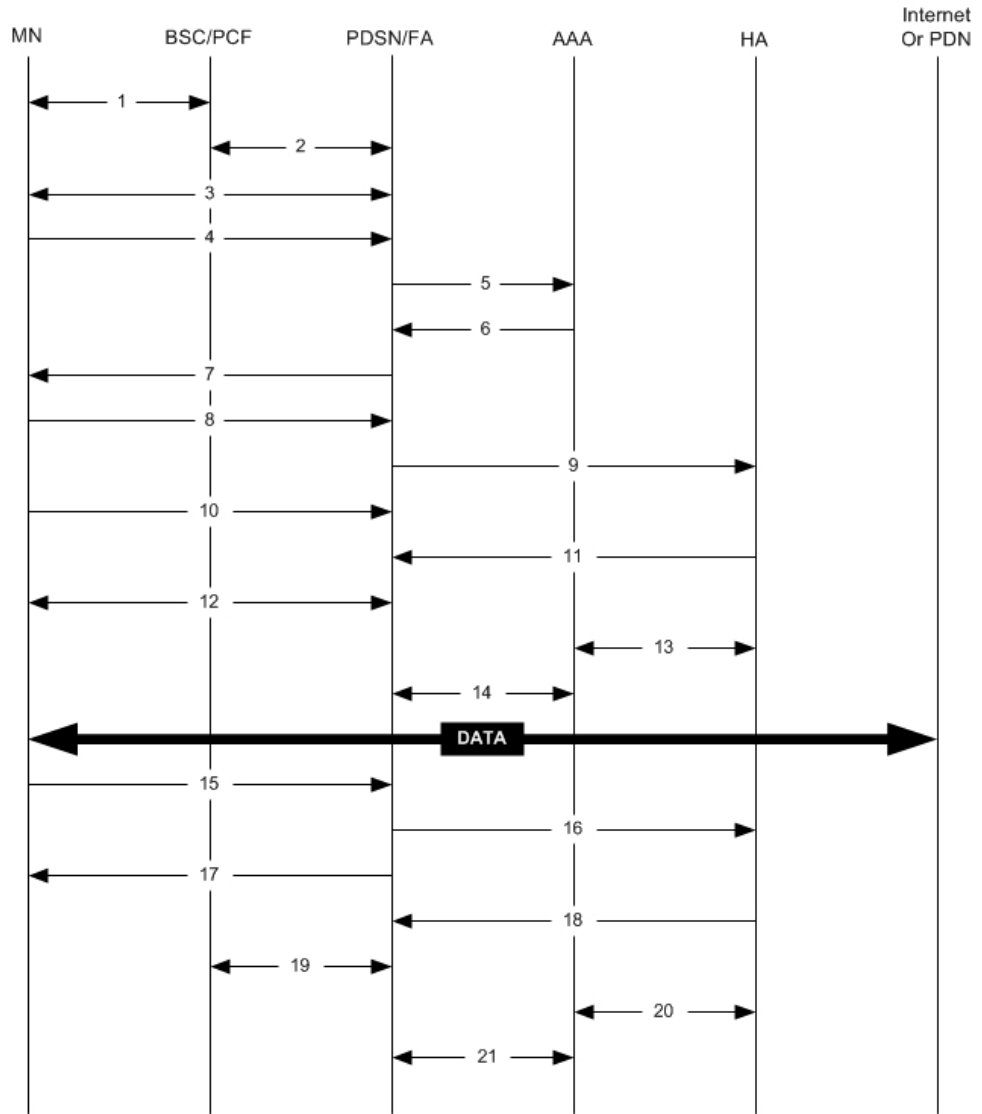

335164

Table 4: HA Assigned IP Address Proxy Mobile IP Call Flow Description

Step	Description
1	Mobile Node (MN) secures a traffic channel over the airlink with the RAN through the BSC/PCF.
2	The PCF and PDSN/FA establish the R-P interface for the session.
3	The PDSN/FA and MN negotiate Link Control Protocol (LCP).

Step	Description
4	Upon successful LCP negotiation, the MN sends a PPP Authentication Request message to the PDSN/FA.
5	The PDSN/FA sends an Access Request message to the RADIUS AAA server.
6	The RADIUS AAA server successfully authenticates the subscriber and returns an Access Accept message to the PDSN/FA. The Accept message may contain various attributes to be assigned to the MN including the IP address of the HA to use.
7	The PDSN/FA sends a PPP Authentication Response message to the MN.
8	The MN sends an Internet Protocol Control Protocol (IPCP) Configuration Request message to the PDSN/FA with an MN address of 0.0.0.0.
9	The PDSN/FA forwards a Proxy Mobile IP Registration Request message to the HA. The message includes such things as a Home Address indicator of 0.0.0.0, the IP address of the FA (the care-of-address), the IP address of the FA (the care-of-address), and the FA-HA extension (Security Parameter Index (SPI)).
10	While the FA is communicating with the HA, the MN may send additional IPCP Configuration Request messages.
11	The HA responds with a Proxy Mobile IP Registration Response. The response includes an IP address from one of its locally configured pools to assign to the MN (its Home Address). The HA also creates a Mobile Binding Record (MBR) for the subscriber session.
12	The MN and the PDSN/FA negotiate IPCP. The result is that the MN is assigned the home address originally specified by the AAA server.
13	While the MN and PDSN/FA are negotiating IPCP, the HA and AAA server initiate accounting.
14	Upon completion of the IPCP negotiation, the PDSN/FA and AAA server initiate accounting fully establishing the session allowing the MN to send/receive data to/from the PDN.
15	Upon completion of the session, the MN sends an LCP Terminate Request message to the PDSN to end the PPP session.

Step	Description
16	The PDSN/FA sends a Proxy Mobile IP De-registration Request message to the HA.
17	The PDSN/FA send an LCP Terminate Acknowledge message to the MN ending the PPP session.
18	The HA sends a Proxy Mobile IP De-Registration Response message to the FA terminating the Pi interface
19	The PDSN/FA and the PCF terminate the R-P session.
20	The HA and the AAA server stop accounting for the session.
21	The PDSN and the AAA server stop accounting for the session.

Supported Standards

The system supports the following industry standards for 1x/CDMA2000/EV-DO devices.

Requests for Comments (RFCs)

- RFC-768, User Datagram Protocol (UDP), August 1980
- RFC-791, Internet Protocol (IP), September 1982
- RFC-793, Transmission Control Protocol (TCP), September 1981
- RFC-894, A Standard for the Transmission of IP Datagrams over Ethernet Networks, April 1984
- RFC-1089, SNMP over Ethernet, February 1989
- RFC-1144, Compressing TCP/IP headers for low-speed serial links, February 1990
- RFC-1155, Structure and Identification of Management Information for TCP/IP-based Internets, May 1990
- RFC-1157, Simple Network Management Protocol (SNMP) Version 1, May 1990
- RFC-1212, Concise MIB Definitions, March 1991
- RFC-1213, Management Information Base for Network Management of TCP/IP-based Internets: MIB-II, March 1991
- RFC-1215, A Convention for Defining Traps for use with the SNMP, March 1991
- RFC-1224, Techniques for Managing Asynchronously Generated Alerts, May 1991
- RFC-1256, ICMP Router Discovery Messages, September 1991
- RFC-1305, Network Time Protocol (Version 3) Specification, Implementation and Analysis, March 1992
- RFC-1332, The PPP Internet Protocol Control Protocol (IPCP), May 1992

- RFC-1398, Definitions of Managed Objects for the Ethernet-Like Interface Types, January 1993
- RFC-1418, SNMP over OSI, March 1993
- RFC-1570, PPP LCP Extensions, January 1994
- RFC-1643, Definitions of Managed Objects for the Ethernet-like Interface Types, July 1994
- RFC-1661, The Point to Point Protocol (PPP), July 1994
- RFC-1662, PPP in HDLC-like Framing, July 1994
- RFC-1701, Generic Routing Encapsulation (GRE), October 1994
- RFC-1771, A Border Gateway Protocol 4 (BGP-4)
- RFC-1850, OSPF Version 2 Management Information Base, November 1995
- RFC-1901, Introduction to Community-based SNMPv2, January 1996
- RFC-1902, Structure of Management Information for Version 2 of the Simple Network Management Protocol (SNMPv2), January 1996
- RFC-1903, Textual Conventions for Version 2 of the Simple Network Management Protocol (SNMPv2), January 1996
- RFC-1904, Conformance Statements for Version 2 of the Simple Network Management Protocol (SNMPv2), January 1996
- RFC-1905, Protocol Operations for Version 2 of the Simple Network Management Protocol (SNMPv2), January 1996
- RFC-1906, Transport Mappings for Version 2 of the Simple Network Management Protocol (SNMPv2), January 1996
- RFC-1907, Management Information Base for Version 2 of the Simple Network Management Protocol (SNMPv2), January 1996
- RFC-1908, Coexistence between Version 1 and Version 2 of the Internet-standard Network Management Framework, January 1996
- RFC-1918, Address Allocation for Private Internets, February 1996
- RFC-1919, Classical versus Transparent IP Proxies, March 1996
- RFC-1962, The PPP Compression Control Protocol (CCP), June 1996
- RFC-1974, PPP STAC LZS Compression Protocol, August 1996
- RFC-2002, IP Mobility Support, May 1995
- RFC-2003, IP Encapsulation within IP, October 1996
- RFC-2004, Minimal Encapsulation within IP, October 1996
- RFC-2005, Applicability Statement for IP Mobility Support, October 1996
- RFC-2118, Microsoft Point-to-Point Compression (MPPC) Protocol, March 1997
- RFC-2136, Dynamic Updates in the Domain Name System (DNS UPDATE)

- RFC-2211, Specification of the Controlled-Load Network Element Service
- RFC-2246, The Transport Layer Security (TLS) Protocol Version 1.0, January 1999
- RFC-2290, Mobile IPv4 Configuration Option for PPP IPCP, February 1998
- RFC-2328, OSPF Version 2, April 1998
- RFC-2344, Reverse Tunneling for Mobile IP, May 1998
- RFC-2394, IP Payload Compression Using DEFLATE, December 1998
- RFC-2401, Security Architecture for the Internet Protocol, November 1998
- RFC-2402, IP Authentication Header (AH), November 1998
- RFC-2406, IP Encapsulating Security Payload (ESP), November 1998
- RFC-2408, Internet Security Association and Key Management Protocol (ISAKMP), November 1998
- RFC-2409, The Internet Key Exchange (IKE), November 1998
- RFC-2474, Definition of the Differentiated Services Field (DS Field) in the IPv4 and IPv6 Headers, December 1998
- RFC-2475, An Architecture for Differentiated Services, December 1998
- RFC-2484, PPP LCP Internationalization Configuration Option, January 1999
- RFC-2486, The Network Access Identifier (NAI), January 1999
- RFC-2571, An Architecture for Describing SNMP Management Frameworks, April 1999
- RFC-2572, Message Processing and Dispatching for the Simple Network Management Protocol (SNMP), April 1999
- RFC-2573, SNMP Applications, April 1999
- RFC-2574, User-based Security Model (USM) for version 3 of the Simple Network Management Protocol (SNMPv3), April 1999
- RFC-2597, Assured Forwarding PHB Group, June 1999
- RFC2598 - Expedited Forwarding PHB, June 1999
- RFC-2618, RADIUS Authentication Client MIB, June 1999
- RFC-2620, RADIUS Accounting Client MIB, June 1999
- RFC-2661, Layer Two Tunneling Protocol "L2TP", August 1999
- RFC-2697, A Single Rate Three Color Marker, September 1999
- RFC-2698, A Two Rate Three Color Marker, September 1999
- RFC-2784, Generic Routing Encapsulation (GRE) - March 2000, IETF
- RFC-2794, Mobile IP Network Access Identifier Extension for IPv4, March 2000
- RFC-2809, Implementation of L2TP Compulsory Tunneling via RADIUS, April 2000
- RFC-2845, Secret Key Transaction Authentication for DNS (TSIG), May 2000

- RFC-2865, Remote Authentication Dial In User Service (RADIUS), June 2000
- RFC-2866, RADIUS Accounting, June 2000
- RFC-2867, RADIUS Accounting Modifications for Tunnel Protocol Support, June 2000
- RFC-2868, RADIUS Attributes for Tunnel Protocol Support, June 2000
- RFC-2869, RADIUS Extensions, June 2000
- RFC-3007, Secure Domain Name System (DNS) Dynamic Update, November 2000
- RFC-3012, Mobile IPv4 Challenge/Response Extensions, November 2000
- RFC-3095, Robust Header Compression (ROHC): Framework and four profiles: RTP, UDP, ESP and uncompressed, July 2001
- RFC-3101, OSPF NSSA Option, January 2003.
- RFC-3141, CDMA2000 Wireless Data Requirements for AAA, June 2001
- RFC-3143, Known HTTP Proxy/Caching Problems, June 2001
- RFC-3193, Securing L2TP using IPSEC, November 2001
- RFC-3241 Robust Header Compression (ROHC) over PPP, April 2002
- RFC-3409, Lower Layer Guidelines for Robust (RTP/UDP/IP) Header Compression, December 2002
- RFC-3519, NAT Traversal for Mobile IP, April 2003
- RFC-3543, Registration Revocation in Mobile IPv4, August 2003
- RFC 3576 - Dynamic Authorization Extensions to Remote Authentication Dial In User Service (RADIUS), July 2003
- RFC-3706, A Traffic-Based Method of Detecting Dead Internet Key Exchange (IKE) Peers, February 2004
- RFC-3759, Robust Header Compression (ROHC): Terminology and Channel Mapping Examples, April 2004
- RFC-3588, Diameter Based Protocol, September 2003
- RFC-4005, Diameter Network Access Server Application, August 2005
- RFC-4006, Diameter Credit-Control Application, August 2005
- Draft, Generalized Key Distribution Extensions for Mobile IP
- Draft, AAA Keys for Mobile IP

TIA and Other Standards

Telecommunications Industry Association (TIA) Standards

- TIA/EIA/IS-835-A, CDMA2000 Wireless IP Network Standard, April 2001
- TIA/EIA/IS-835-B, CDMA2000 Wireless IP Network Standard, October 2002

- TIA/EIA/IS-835-C, CDMA2000 Wireless IP Network Standard, August 2003
- TIA/EIA/IS-707-A-1, Data Service Options for Wideband Spread Spectrum Systems
- TIA/EIA/IS-707-A.5 Packet Data Services
- TIA/EIA/IS-707-A.9 High Speed Packet Data Services
- TIA/EIA/IS-2000.5, Upper Layer (Layer 3) Signaling for CDMA2000 Spread Spectrum Systems
- TIA/EIA/IS-2001, Interoperability Specifications (IOS) for CDMA2000 Access Network Interfaces
- TIA/EIA/TSB100, Wireless Network Reference Model
- TIA/EIA/TSB115, CDMA2000 Wireless IP Architecture Based on IETF Protocols
- TIA/EIA J-STD-025 PN4465, TR-45 Lawfully Authorized Electronic Surveillance

Object Management Group (OMG) Standards

- CORBA 2.6 Specification 01-09-35, Object Management Group

3GPP2 Standards

- 3GPP2 A.S0001-A v2: 3GPP2 Access Network Interfaces Interoperability Specification (also known as 3G-IOS v4.1.1)
- 3GPP2 P.S0001-A-3: Wireless IP Network Standard
- 3GPP2 P.S0001-B: Wireless IP Network Standard
- 3GPP2 S.R0068: Link Layer Assisted Robust Header Compression
- [9] 3GPP2 C.S0047-0: Link Layer Assisted Service Options for Voice-over-IP: Header Removal (SO60) and Robust Header Compression (SO61)
- 3GPP2 A.S0008 v3.0 Interoperability Specification (IOS) for High Rate Packet Data (HRPD) Access Network Interfaces
- 3GPP2 A.S0015-0 v2: Interoperability Specification (IOS) for CDMA2000 1X Access Network Interfaces — Part 5 (A3 and A7 1X Interfaces) (Partial Support) (also know as 3G-IOSv4.2)
- 3GPP2 P.S0001-B V1.0.0 Wireless IP Network Standard October 25, 2002 (relating to MIP interactions with IPSEC)
- 3GPP2 P.S0001 (TIA/EIA/IS-835-1) Version 1.0, Wireless IP Network Standard - December 10, 1999
- 3GPP2 P.R0001 (TSB115) Version 1.0.0, Wireless IP: Architecture Based on IETF Protocols - July 14, 2000
- 3GPP2 3GPP2 X.S0011-005-C Version: 1.0.0, CDMA2000 Wireless IP Network Standard: Accounting Services and 3GPP2 RADIUS VSAs - August 2003
- 3GPP2 X.S0011-006-C Version: 1.0.0, CDMA2000 Wireless IP Network Standard: PrePaid Packet Data Service - Date: August 2003
- 3GPP2 TSGA A.S0013-c v0.4 Interoperability Specification (IOS) for CDMA2000 June 2004

- 3GPP2 TSG-A A.S.0017-C baseline Interoperability Specification (IOS) for CDMA2000 Access Network Interfaces - Part 7(A10 and A11 Interfaces) (IOS v5.0 baseline) June 2004
- 3GPP2 A.S0012-D Segmentation for GRE January, 2005
- Inter-operability Specification (IOS) for CDMA2000 Access Network Interfaces
- 3GPP2 X.S0011-005-D Accounting Services and 3GPP2 RADIUS VSAs, February 2006
- 3GPP2 TSG-X (PSN) X.P0013-014-0, Service Based Bearer Control – Ty Interface Stage-3

IEEE Standards

- 802.1Q VLAN Standard



CHAPTER 2

Understanding the Service Operation and Configuration

The system provides wireless carriers with a flexible solution that can support both Simple IP and Mobile IP applications (independently or simultaneously) within a single scalable platform. Simple IP and Mobile IP applications are described in detail in the *System Overview Guide*.

When supporting Simple IP data applications, the system is configured to perform the role of a Packet Data Serving Node (PDSN) within the carrier's 3G CDMA2000 data network. The PDSN terminates the mobile subscriber's Point-to-Point Protocol (PPP) session and then routes data to and from the packet data network (PDN) on behalf of the subscriber. The PDN could consist of Wireless Application Protocol (WAP) servers or it could be the Internet.

When supporting Mobile IP data applications, the system can be configured to perform the role of the PDSN/Foreign Agent (FA) and/or the Home Agent (HA) within the carrier's 3G CDMA2000 data network. When functioning as an HA, the system can either be located within the carrier's 3G network or in an external enterprise or ISP network. Regardless, the PDSN/FA terminates the mobile subscriber's PPP session, and then routes data to and from the appropriate HA on behalf of the subscriber.

Prior to connecting to the command line interface (CLI) and beginning the system's configuration, there are important things to understand about how the system supports these applications. This chapter provides terminology and background information that must be considered before attempting to configure the system.

The following topics are included:

- [Terminology, on page 47](#)
- [How the System Selects Contexts, on page 55](#)

Terminology

This section defines some of the terms used in this manual.

Contexts

A context is a logical grouping or mapping of configuration parameters that pertain to various physical ports, logical IP interfaces, and services. A context can be thought of as a virtual private network (VPN).

The system supports the configuration of multiple contexts. Each is configured and operates independently from the others. Once a context has been created, administrative users can then configure services, logical IP

interfaces, subscribers, etc. for that context. Administrative users would then bind the logical interfaces to physical ports.

Contexts can also be assigned domain aliases, wherein if a subscriber's domain name matches one of the configured alias names for that context, then that context is used.

Contexts on the system can be categorized as follows:

- **Source context:** Also referred to as the "ingress" context, this context provides the subscriber's point-of-entry in the system. It is also the context in which services are configured. For example, in a CDMA2000 network, the radio network containing the packet control functions (PCFs) would communicate with the system via R-P interfaces configured within the source context as part of the PDSN service.
- **Destination context:** Also referred to as the "egress" context, this context is where a subscriber is provided services (such as access to the Internet). Destination contexts are typically named after particular domains. For example, the system's destination context would be configured with the interfaces facilitating subscriber data traffic to/from the Internet, a VPN, or other PDN.
- **AAA context:** This context provides authorization, authentication, and accounting (AAA) functionality for subscriber and/or administrative user sessions. The AAA context contains context-specific AAA policies, the logical interfaces for communicating with AAA servers, and records for locally configured subscribers and/or administrative users.



Important

It is important to note that "source," "destination," and AAA functionality can optionally be configured within the same context or be configured as separate contexts. As a general rule, however, if the carrier owns and operates the AAA server, it is recommended that AAA functionality be configured within the source context. Conversely, if a home network other than the carrier's own operates the AAA server, it is recommended that AAA functionality be configured within the destination context.

To ensure scalability, AAA functionality for subscriber sessions should not be configured in the local out-of-band context.

AAA Realms

A AAA realm is the location within the AAA context where subscriber-specific templates can be defined that are applied to subscribers who match that realm. A AAA realm is considered part of the AAA context; and the AAA context itself is also considered to be a realm. There may be many different AAA realms defined within a single AAA context.

An example of a realm would be that within a source context named `ingress`, there could be a domain alias of `nova.com`, another domain alias of `bigco.com`, and a single AAA configuration that is used by the entire system. In this example, the source context is also serving as a AAA context. There would be three specific AAA realms in this case; `ingress`, `nova.com`, and `bigco.com`, since all three could have their own subscriber templates defined.

The primary purpose of a AAA realm is to host a subscriber template for each realm that provides AAA attributes that may be used in the event that an authenticated subscriber's access-accept message from RADIUS fails to contain certain attributes. In this case, the default attributes contained in the realm-based subscriber template would be used. However, if the RADIUS authentication message contains an attribute from that subscriber's RADIUS user profile, then that information will be used to overwrite any default attribute parameters that are contained in the subscriber template.

More information about subscriber templates will be provided later in this chapter when subscribers are discussed.

Realms must be globally unique in their naming convention in that each realm name can only be used in one context in one system.

Ports

Ports are the physical interfaces that reside upon the system's line cards (Ethernet 10/100, Gigabit Ethernet 1000 Line Cards and the four-port Quad Gigabit Ethernet Line Card otherwise known as the Quad Gig-E or QGLC). Ethernet Port configuration addresses traffic profiles, data encapsulation methods, media type, and other information needed to allow physical connectivity between the system and the rest of the network. Ports are identified by the chassis slot number in which the line card resides, followed by the number of the physical connector on the line card. For example, Port 24/1 identifies connector number 1 on the card in slot 24.

Ports are associated with contexts through bindings. Additional information on bindings can be found in the Bindings section. Each physical port can be configured to support multiple logical IP interfaces each with up to 17 IP addresses (one primary and up to 16 secondaries).

Logical Interfaces

Prior to allowing the flow of user data, the port must be associated with a virtual circuit or tunnel called a logical interface. A logical interface within the system is defined as the logical assignment of a virtual router instance that provides higher-layer protocol transport, such as Layer 3 IP addressing. Interfaces are configured as part of the VPN context and are independent from the physical port that will be used to bridge the virtual interfaces to the network.

Logical interfaces are assigned to IP addresses and are bound to a specific port during the configuration process. Logical interfaces are also associated with services through bindings. Services are bound to an IP address that is configured for a particular logical interface. When associated, the interface takes on the characteristics of the functions enabled by the service. For example, if an interface is bound to a PDSN service, it will function as an R-P interface between the PDSN service and the PCF. Services are defined later in this section.

There are several types of logical interfaces that must be configured to support Simple and Mobile IP data applications as described below:

- **Management interface:** This interface provides the system's point of attachment to the management network. The interface supports remote access to the system CLI, Common Object Request Broker Architecture (CORBA)-based management via the Web Element Manager application, and event notification via the Simple Network Management Protocol (SNMP).

The system defaults to a Local context which should not be deleted. Management interfaces are defined in the Local management context and should only be bound to the ports on the Switch Processor Input/Output (SPIO) cards port on the Virtual Management Card.

- **R-P interface:** Also referred to as the A10/A11 interface, this interface is the communications path between the Radio Node (also referred to as a PCF) and the PDSN.

The A10/A11 interface carries traffic signaling (A11) and user data traffic (A10). The A10/A11 interface is implemented in accordance with IS-835.

R-P interfaces are bound to ports on either the Ethernet 10/100 or Ethernet 1000/QGLC Line Cards.

- **Pi interface:** The packet interface (Pi) is the communications path between the PDSN/Foreign Agent (PDSN/FA) and the Home Agent (HA) for Mobile IP applications.

Pi interfaces are bound to ports on either the Ethernet 10/100 or Ethernet 1000/QGLC Line Cards.

- **PDN interface:** The interface to the packet data network (PDN). For Simple IP applications, this is the communications path between the PDSN and the PDN. For Mobile IP applications, this is the communications path between the HA and the PDN.

PDN interfaces are bound to Ethernet ports.

- **AAA interface:** The AAA interface is the connection between the PDSN and/or HA and the network servers that perform AAA functions. With this release of the system, the Remote Authentication Dial-In User Service (RADIUS) Protocol is used for communication on this interface.

AAA interfaces are bound to Ethernet ports. However, AAA interfaces can also be bound to the Local management context and to virtual management ports on the SPIO to provide AAA functions for subscribers, and for context-level administrative users.

- **ICC interface:** Inter-context communication (ICC) interfaces are only required when multiple services are configured in the same context. As mentioned previously, services are bound to interfaces. Creating an ICC interface provides a communication path between the services. For example, if an FA and HA service were configured in the same context, the FA service would need to be bound to an address assigned to the ICC interface and the HA service would need to be bound to a secondary address on the same ICC interface to provide a communications path between the two services.

The ICC interface must be configured with multiple addresses (one per service that it is facilitating) and bound to a physical port.

Bindings

A binding is an association between "elements" within the system. There are two types of bindings: static and dynamic.

Static binding is accomplished through the configuration of the system. Static bindings are used to associate:

- A specific logical interface (configured within a particular context) to a physical port. Once the interface is bound to the physical port, traffic can flow through the context just as if it were any physically defined circuit. Static bindings support any encapsulation method over any interface and port type.
- A service to an IP address assigned to a logical interface within the same context. This allows the interface to take on the characteristics (i.e., support the protocols) required by the service. For example, a PDSN service bound to a logical interface will cause the logical interface to take on the characteristics of an R-P interface within a 3G CDMA2000 network.

Dynamic binding associates a subscriber to a specific egress context based on the configuration of their profile or system parameters. This provides a higher degree of deployment flexibility as it allows a wireless carrier to support multiple services and facilitates seamless connections to multiple networks.

Services

Services are configured within a context and enable certain functionality. The following services can be configured on the system:

- **PDSN services:** Required for both Simple IP and Mobile IP applications, PDSN services define PDSN functionality for the system. The PDSN service must be bound to a logical interface within the same context. Once bound, the interface takes on the characteristics of an R-P interface. Multiple services can be bound to the same logical interface. Therefore, a single physical port can facilitate multiple R-P interfaces.

The system treats the connection between the PCF and the PDSN service as a VPN (referred to as an RP-VPN). Individual R-P sessions are identified on this RP-VPN using the PCF address, the PDSN interface address, and the R-P Session ID.

- **FA services:** Currently supported only for use in CDMA 2000 networks, FA services are configured to support Mobile IP and define FA functionality on the system.

The system supports multiple Mobile IP configurations. A single system can perform the function of a FA only, an HA only, or a combined PDSN/FA/HA. Depending on your configuration, the FA service can create and maintain the Pi interface between the PDSN/FA and the HA or it can communicate with an HA service configured within the same context.

The FA service should be configured in a different context from the PDSN service. However, if the FA service will be communicating with an HA that is a separate network element, it must be configured within the same context as and be bound to the Pi interfaces that allow it to communicate with the HA.

- **HA services:** Currently supported only for use in CDMA 2000 networks, HA services are configured to support Mobile IP and define HA functionality on the system. Depending on your configuration, the HA service can be used to terminate the Pi interface from the FA or it can communicate with an FA service configured in the same context.

If the HA service is configured within the same system as the PDSN/FA, then it should be configured within the same context as the FA service. This context, then, would also facilitate the PDSN interfaces to the data network.

If the HA service is configured in a separate system, it should be configured in the same context as and bound to the Pi interfaces that allow it to communicate with the FA.

- **LAC services:** LAC services are configured on the system to provide Layer 2 Tunneling Protocol (L2TP) access concentrator (LAC) functionality. LAC services can be configured and used within either CDMA 2000 or GPRS/UMTS networks to provide secure tunneling to an L2TP network server (LNS) on a remote PDN.

The following figure diagrams the relationship between services, interfaces, and contexts within the system for CDMA 2000 networks.

Figure 10: Service, Interface, and Context Relationship Within the System for CDMA 2000 Networks

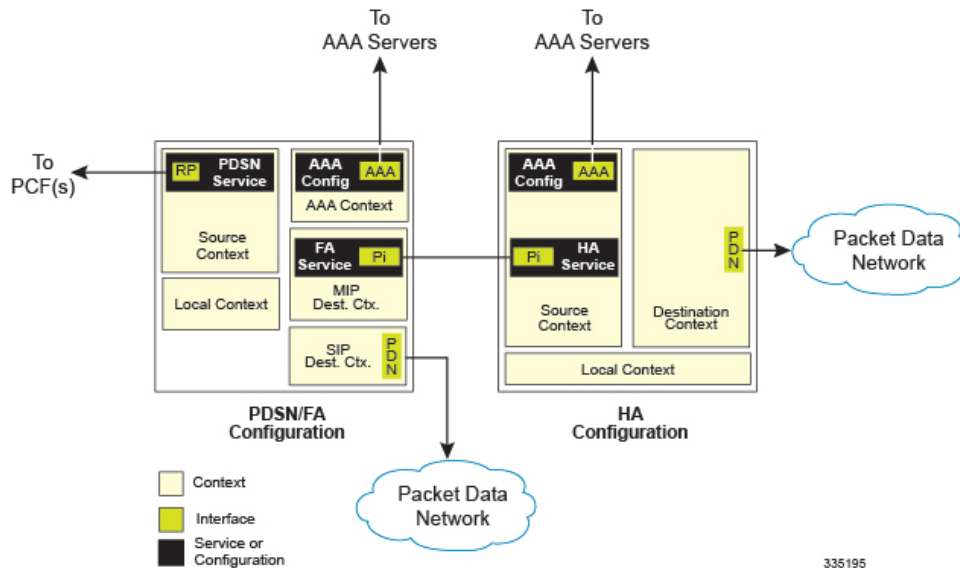

335195

AAA Servers

For most configurations, AAA servers will be used to store profiles, perform authentication, and maintain accounting records for each mobile data subscriber. The AAA servers communicate with the system over the AAA interface. The system supports the configuration of up to 128 AAA servers with which to communicate.

It is important to note that for Mobile IP, there can be foreign AAA (FAAA) and home AAA (HAAA) servers. The FAAA server(s) typically resides in the carrier's network. The HAAA server(s) could be owned and controlled by either the carrier or the home network. If the HAAA server is owned and controlled by the home network, accounting data can be transferred to the carrier via a AAA proxy server.

For most configurations, AAA servers will be used to store subscriber profiles and perform authentication. In addition, RADIUS AAA servers may be used to maintain accounting records for each mobile data subscriber as opposed to a GTPP-based Charging Gateway Function (CGF). The AAA servers communicate with the system over the AAA interface. The system supports the configuration of up to 128 AAA servers with which to communicate.

Subscribers

Subscribers are the end-users of the service who gain access to the Internet, their home network, or a public network through the system. There are three primary types of subscribers/users:

- **RADIUS-based Subscribers:** The most common type of subscriber, these users are identified by their International Mobile Subscriber Identity (IMSI) number, an Electronic Serial Number (ESN), or by their domain name or user name and are configured on and authenticated by a RADIUS AAA server.

Upon successful authentication various attributes (contained in the subscriber profile) are returned that dictate such things as session parameter settings (e.g. protocol settings, IP address assignment method, etc.), and what privileges the subscriber has (e.g. Simple IP, Mobile IP, etc.).

Attribute settings received by the system from a RADIUS AAA server take precedence over local-subscriber attributes and parameters configured on the system.

- **Local Subscribers:** These are subscribers, primarily used for testing purposes, that are configured and authenticated within a specific context. Unlike RADIUS-based subscribers, the local subscriber's user profile (containing attributes like those used by RADIUS-based subscribers) is configured within the context where they are created.

When local subscriber profiles are first created, attributes for that subscriber are set to the system's default settings. The same default settings are applied to all subscriber profiles including the subscriber named default (created automatically by the system for each system context; refer to the Default Subscribers and Realm-based Subscriber Templates section for more information). When configuring local profile attributes, the changes are made on a subscriber-by-subscriber basis.

Attributes configured for local subscribers take precedence over context-level parameters. However, they could be over-ridden by attributes returned from a RADIUS AAA server.

- **Management Subscribers:** A management user is an authorized user who can monitor, control, and configure the system through its command line interface (CLI) or Web Element Manager application. This management can be performed either locally, through the system's console port, or remotely through the use of the Telnet or secure shell (SSH) protocols. Management users are typically configured as a local subscriber within the localout-of-band management context, which is used exclusively for system management and administration. Like a local subscriber, the management subscriber's user profile is configured within the context where they are created (in this case the localout-of-band management context). However, management subscribers may also be authenticated remotely via RADIUS, if a AAA configuration exists within the localout-of-band management context.

Default Subscribers and Realm-based Subscriber Templates

Used for RADIUS-based subscribers, default subscribers – created on a per context basis, and subscriber templates – optionally created on per realm basis, contain default AAA attributes that can be used by subscribers who are remotely authenticated within a specific context or domain alias (AAA realm) when needed.

Default Subscriber

When each context is created, the system automatically creates a subscriber named default. There is only one default subscriber per context. The profile for the subscriber named default provides a configuration template of attribute values for subscribers who are remotely authenticated in that context. Any subscriber information that is not included in a RADIUS-based subscriber's user profile is configured according to the defaults defined for the default subscriber.

No matter where created all default subscribers initially have the same attributes set. The attributes for the default subscriber in each context can be changed from the CLI on a context by context basis.



Important

Local subscribers, who are authenticated locally within the context where they were created, cannot use any attributes that are defined for subscriber default. Rather, each local subscriber must have any attributes configured for them individually.

Realm-based Subscriber Templates

As defined earlier, a context can have numerous domain aliases that allows a single context to serve numerous different subscribers who have different domain names. When assigned, these domain aliases become AAA realms within the context.

Since each realm is used for a specific group of subscribers (e.g. corporate subscribers who may only have access to a specific corporate network that is protected by a virtual private network), each realm must have the ability to define what AAA attributes should be applied to these different subscriber groups. This is achieved through the use of realm-based subscriber templates.

A subscriber template contains defined attributes that are specific to a select subscriber who belongs to that realm. Like the default subscriber (subscriber named default) who has a context-level set of configuration attributes, the subscriber template is used to provide default attribute values that may be used should a RADIUS user profile for a subscriber belonging to the specific realm fail to contain a needed attribute.



Important

If a realm-based subscriber template is not created for a specified realm, then the system will use the attributes configured for default subscriber (named default) within the context where the AAA realm exists.

Below is an example of how realm-based subscriber templates may be used.

As depicted above, a context named "ingress" contains:

- a PDSN service named "PDSN".
- a AAA configuration that is used to communicate with an external RADIUS server. A default subscriber for the context named "default". This default subscriber has an idle timeout attribute value of 45000 seconds.
- three additional realms, based on the following domain alias names:
 - "mega.com", which has a realm-based subscriber template named "megauser". This template contains an idle timeout attribute value of 36000 seconds.
 - "bigco.com", which has a realm-based subscriber template named "bigco". This template contains an idle timeout attribute value of 3600 seconds.
 - "smallco.com", which has no realm-based subscriber template defined.

For this example, we will assume that all subscribers enter the system through the PDSN service defined in the [ingress] context. Configuration procedures and context selection methods will be provided in other sections in this document.

If a subscriber enters the system with a domain name that matches the context name "ingress" (example: user1@ingress), then the [ingress] context would be used for authentication. If the RADIUS server authenticates the subscriber and returns no value for the idle-timeout attribute, then this subscriber would be assigned the value contained in the subscriber default configuration. If a subscriber named user@mega.com enters the system with a domain name that matches a configured domain alias within the [ingress] context, in this case "mega.com", then the [ingress] context would be used for authentication. However, since a realm-based subscriber template named "megauser" is defined within this AAA realm, then should the RADIUS server return no value for the idle-timeout attribute, then this subscriber would be assigned the value contained in the "megauser" subscriber template.

If a subscriber named user@bigco.com enters the system with a domain name that matches a configured domain alias within the [ingress] context, in this case "bigco.com", then the [ingress] context would be used for authentication. However, since a realm-based subscriber template name "bigco" is defined within this AAA realm, any attributes not returned could be assigned from this subscriber template. In this example, the RADIUS server returns an idle-timeout of 18000 seconds. Because the RADIUS user profile contained a value for this attribute, the system would use that value (18000) rather than the value defined in the subscriber template.

If a subscriber name `user@smallco.org` enters the system with a domain name that matches a configured domain alias within the `[ingress]` context, in this case `"smallco.org"`, then the `[ingress]` context would be used for authentication. Note that the `"smallco.org"` domain alias does not have a realm-based subscriber template defined. In this case, the system would obtain any attribute values not returned from the RADIUS server from the subscriber default configuration. So if no attribute value was returned from RADIUS, `user@smallco.org` would be assigned an idle-timeout value of 45000 seconds.

How the System Selects Contexts

The previous section of this chapter defined what a context is and how it is used within the system. This section provides details about the process that is used to determine which context to use for context-level administrative user and/or subscriber sessions. Understanding this process allows you to better plan your configuration in terms of how many contexts and interfaces need to be configured.

Context Selection for Context-level Administrative User Sessions

The system comes configured with a context called local management context that should be used specifically for management purposes. The context selection process for context-level administrative users (those configured within a context) is simplified because the management interface(s) on the SPIO are only associated with the local out-of-band management context. Therefore, the source and destination contexts for a context-level administrative user responsible for managing the entire system should always be the local management context.

Although this is not commonly done, a context-level administrative user can also connect through other interfaces on the system and still have full system management privileges. A context-level administrative user can be created in a non-local management context. These management accounts only have privileges in the context where they are created. This type of management account can connect directly to a port in the context in which they belong, if local connectivity is enabled (SSHD for example) in that context. For all FTP or SFTP connections, you must connect through a SPIO interface. If you SFTP or FTP as a non-local management context account you must use the username syntax of `usernamecontextname`.

The context selection process becomes more involved depending on whether or not you will be configuring the system to provide local authentication or work with a AAA server to authenticate the context-level administrative user.

The system provides the flexibility to configure context-level administrative users locally (meaning that their profile will be configured and stored in its own memory) or remotely on an AAA server. If the user is configured locally, when he/she attempts to log onto the system, the system performs the authentication. If the user profile is configured on a AAA server, the system must determine how to contact the AAA server in order to perform authentication. It does this by determining the AAA context for the session.

The following table and figure describe the process that the system uses to select an AAA context for a context-level administrative user.

Table 5: Context-level Administrative User AAA Context Selection

Item	Description
1	<p>During authentication, the system determines if local authentication is enabled in the local management context.</p> <p>If it is, the system attempts to authenticate the administrative user in the local out-of-band management context. If it is not, proceed to item 2 in this table.</p> <p>If the administrative user's username is configured, authentication is performed using the AAA configuration within the local management context. If not, proceed to item 2 in this table.</p>
2	<p>If local authentication is disabled on the system or if the administrative user's username is not configured in the local management context, then the system determines if a domain was received as part of the username.</p> <p>If there is a domain and it matches the name of a configured context or domain, then the AAA configuration within that context is used.</p> <p>If there is a domain and it does not match the name of a configured context or domain, go to item 4 in this table.</p> <p>If there is no domain as part of the username, go to item 3 in this table.</p>
3	<p>If there was no domain specified in the username or the domain is not recognized, the system determines if an AAA Administrator Default Domain is configured.</p> <p>If the default domain is configured and it matches a configured context, then the AAA configuration within the AAA Administrator Default Domain context is used.</p> <p>If the default domain is not configured or does not match a configured context or domain, go to item 4 in this table.</p>

Item	Description
4	<p>If a domain was specified as part of the username but it did not match a configured context, or if a domain was not specified as part of the username, the system determines if the AAA Administrator Last Resort context parameter is configured.</p> <p>If a last resort context is configured and it matches a configured context, then the AAA configuration within that context is used.</p> <p>If a last resort context is not configured or does not match a configured context or domain, then the AAA configuration within the local management context is used.</p>

Context Selection for Subscriber Sessions

The context selection process for a subscriber session is more involved than that for the administrative users.

The source context used to service a subscriber session is mostly dependant on the mapping of PCFs to PDSNs. Depending on this mapping and the subscribers' location in the network, the same subscriber may initiate several different data sessions throughout the day and have their session serviced by several different source contexts.

The AAA and destination context selection is determined based on what services are provided to the subscriber. For example, a carrier may only offer wireless Internet access and therefore be responsible for performing AAA functions for a subscriber session and for providing the network interfaces to the Internet. In this example, the carrier may choose to combine the source and AAA contexts into one and provide a separate destination context. Another carrier may choose to provide both wireless Internet access and VPN service to a corporate or Internet Service Provider (ISP) network. The system is flexible enough to simultaneously support these services because of the unique way in which it determines how to provide AAA functionality and route the session to the appropriate destination.

The following two sections provide details on the system's process in determining the correct AAA and destination contexts for a subscriber session.

AAA Context Selection for Subscriber Sessions

The following table and figure describe the process that the system uses to select an AAA context for a subscriber.

Table 6: Subscriber AAA Context Selection

Item	Description
1	<p>During authentication, the system determines if a domain was received as part of the username.</p> <p>If there is a domain and it matches the name of a configured context or domain alias, then the AAA configuration within that context is used.</p>

Item	Description
2	<p>If there was no domain specified in the username, the system determines if an AAA Subscriber Default Domain was configured. The AAA Subscriber Default Domain parameter is a system-wide AAA parameter that provides the system with the name of a context or domain that can provide AAA functions.</p> <p>If the AAA Subscriber Default Domain is configured and it matches a configured context or domain, then the AAA configuration within the AAA Subscriber Default Domain context is used.</p> <p>If the AAA Subscriber Default Domain is not configured or does not match a configured context or domain, then the system determines if an AAA Subscriber Last Resort is configured.</p>

Figure 11: Subscriber AAA Context Selection

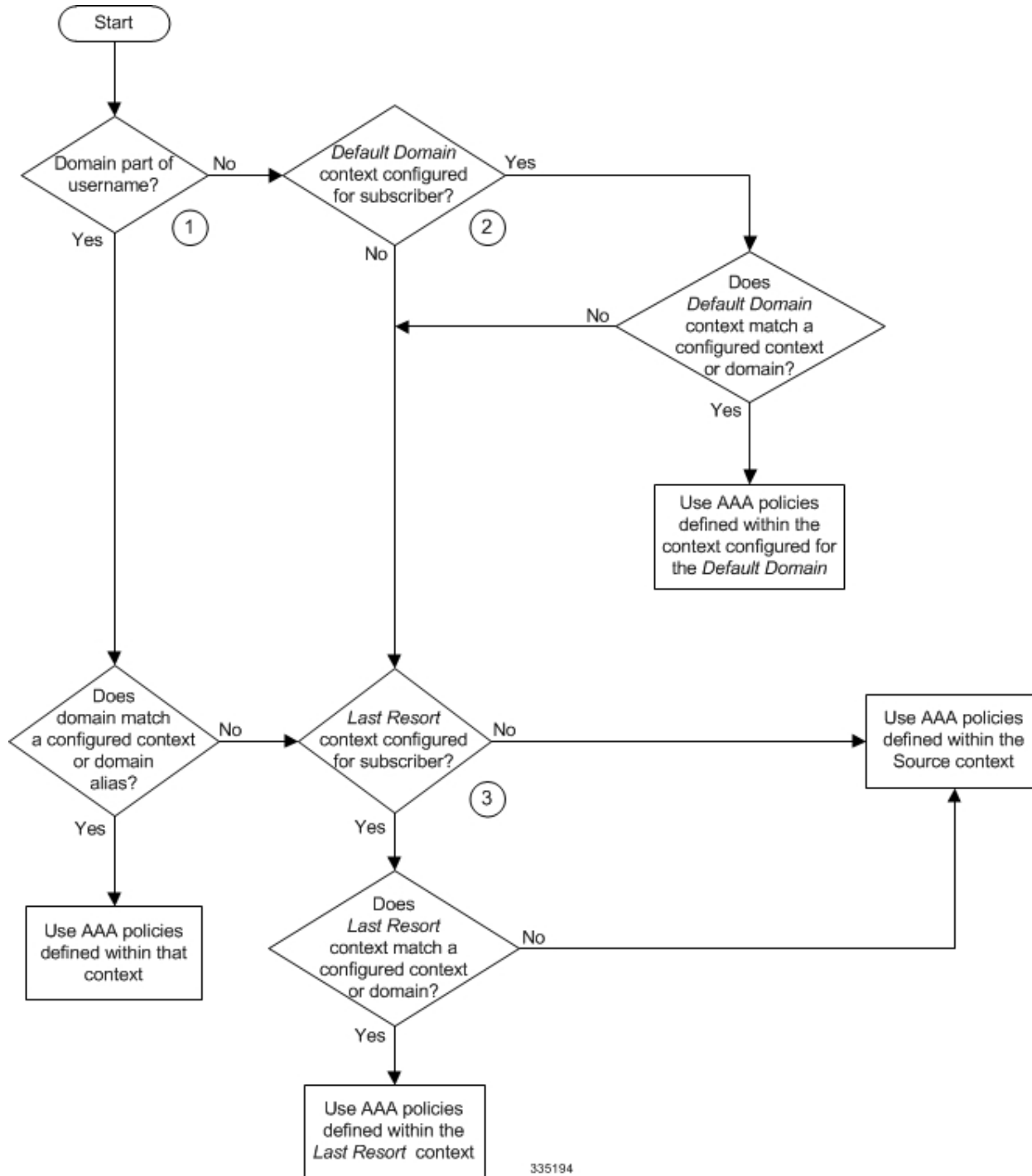

Destination Context Selection For Subscriber Sessions

This section provides information on how a destination context is selected for subscribers whose profiles are configured on a RADIUS AAA server and for those whose profiles are locally configured. Note that the destination context for context-level administrative users is always the local management context.

The following table describes the process that the system uses to select a destination context for a RADIUS-based subscriber whose profile is configured on a RADIUS AAA server and for a subscriber whose profile is configured within a specific context.

Table 7: Subscriber Destination Context Selection

Item	Description
1	<p>The system supports a RADIUS attribute called SN1-VPN-name (or SN-VPN-name in some dictionaries). This attribute specifies the name of the subscriber's destination context. If configured in the subscriber's RADIUS user profile, it will be returned as part of the Access Accept message. If the SN1-VPN-Name attribute is returned, and it matches a configured context, then that context is used as the destination context.</p> <p>If the SN1-VPN-Name attribute is returned, and it does not match a configured context, the call is rejected.</p> <p>If the SN1-VPN-Name attribute is not returned with a value, go to item 2 in this table.</p>
2	<p>The system attempts to use the ip context name parameter configuration for the realm-based subscriber template or context-level default subscriber configured within the AAA context. If a realm-based subscriber template does not exist, go to item 3 in this table. If a realm-based subscriber template exists, the system checks to see if ip context-name is configured in the template.</p> <p>If ip context-name is not configured in the template, the AAA context is used for the destination context.</p> <p>If ip context-name is configured in the template, a check is made to see if it matches the name of a configured context.</p> <p>If ip context-name is configured in the template, but does not match the name of a configured context, the call is rejected.</p> <p>If ip context-name is configured in the template, and matches the name of a configured context, the destination context is set to the ip name-context f or the default subscriber.</p>

Item	Description
3	<p>The local default subscriber profile contains an attribute called ip context-name. This attribute specifies the destination context to use for a local subscriber.</p> <p>If ip context-name is not configured, the AAA context is used for the destination context. If ip context-name is configured, a check is made to see if it matches the name of a configured context.</p> <p>If ip context-name is configured, but does not match the name of a configured context, the AAA context is used for the destination context.</p> <p>If ip context-name is configured, and matches the name of a configured context, the destination context is set to the ip name-context for the default subscriber.</p>

Figure 12: Subscriber Destination Context Selection

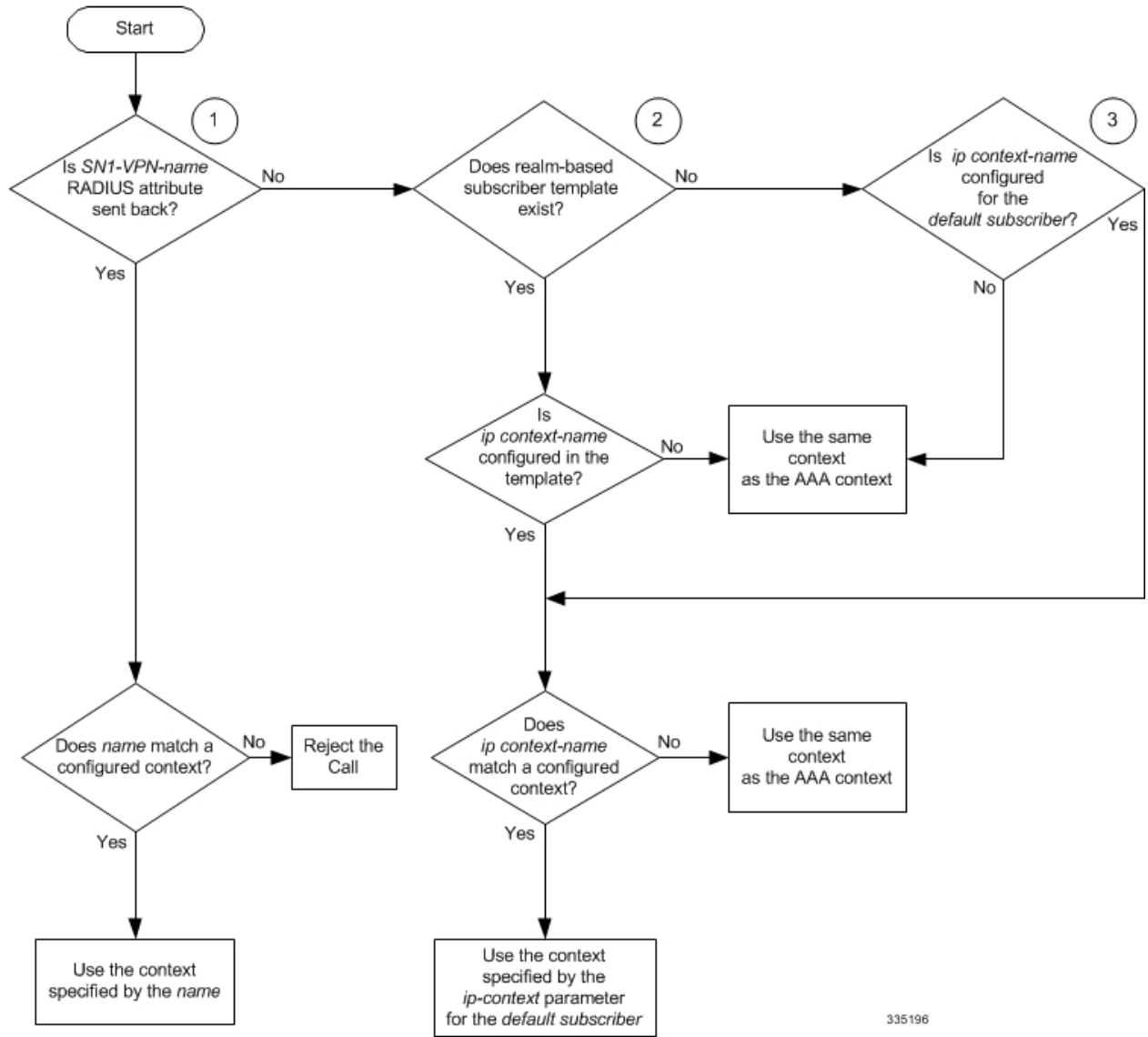

335196



CHAPTER 3

Simple IP Configuration Examples

This chapter provides information for several configuration examples that can be implemented on the system to support Simple IP data services.



Important

This chapter does not discuss the configuration of the local context. Information about the local management context can be found in the *Command Line Interface Reference* guide.

- [Example 1: Simple IP Support Using a Single Source and Destination Context, on page 63](#)
- [Example 2: Simple IP Using a Single Source Context and Multiple Outsourced Destination Contexts, on page 73](#)

Example 1: Simple IP Support Using a Single Source and Destination Context

The most simple configuration that can be implemented on the system to support Simple IP data applications requires that two contexts (one source and one destination) be configured on the system as shown below.

Figure 13: Simple IP Support Using a Single Source and Destination Context

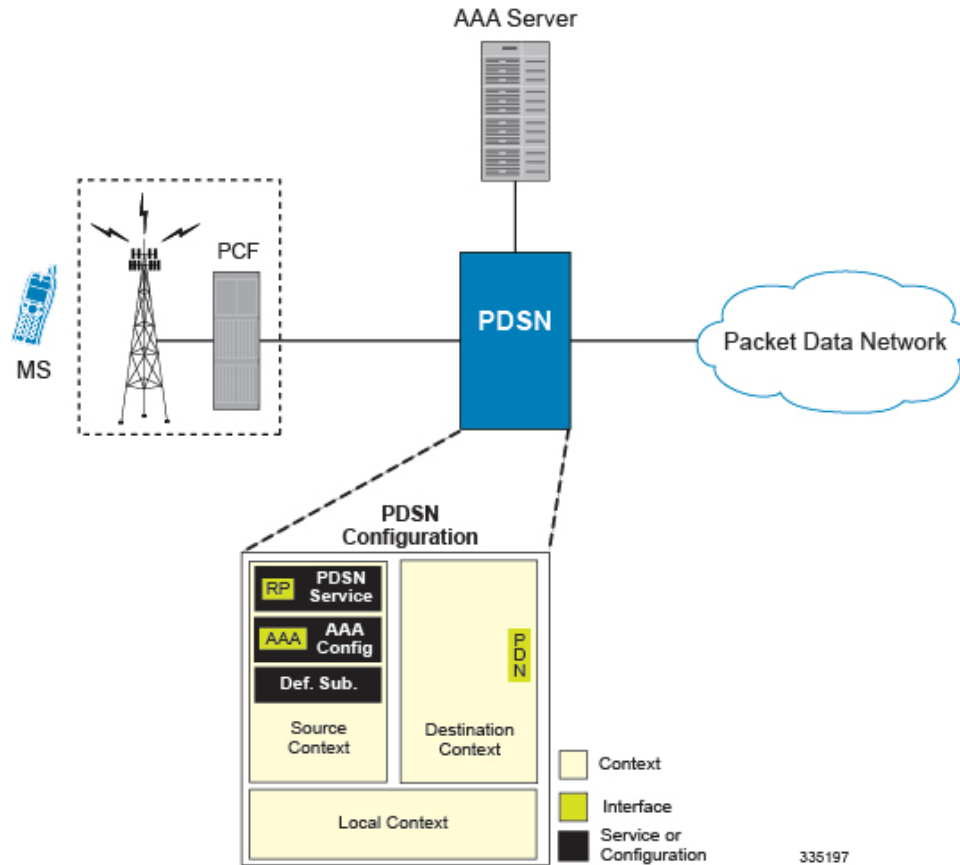

The source context will facilitate the packet data serving node (PDSN) service(s) and the R-P and AAA interfaces. The source context will also be configured to provide AAA functionality for subscriber sessions. The destination context will facilitate the packet data network interface(s).

In this configuration, the wireless carrier provides the function of an Internet Service Provider (ISP) to their subscribers. The PDSN service in the source context terminates subscriber point-to-point protocol (PPP) sessions and routes their data traffic through the destination context to and from a packet data network such as the Internet.

Information Required

Prior to configuring the system as shown in this example, there is a minimum amount of information required. The following sections describe the information required to configure the source and destination contexts.

Source Context Configuration

The following table lists the information that is required to configure the source context.

Table 8: Required Information for Source Context Configuration

Required Information	Description
Source context name	This is an identification string between 1 and 79 characters (alpha and/or numeric) by which the source context will be recognized by the system.
R-P Interface Configuration	
R-P interface name	This is an identification string between 1 and 79 characters (alpha and/or numeric) by which the interface will be recognized by the system. Multiple names are needed if multiple interfaces will be configured. R-P interfaces are configured in the source context.
IP address and subnet	These will be assigned to the R-P interface. Multiple addresses and/or subnets are needed if multiple interfaces will be configured.
Physical port number	This specifies the physical port to which the interface will be bound. Ports are identified by the chassis slot number where the line card resides in, followed by the number of the physical connector on the line card. For example, port 17/1 identifies connector number 1 on the card in slot 17. A single physical port can facilitate multiple interfaces.
Physical port description	This is an identification string between 1 and 79 characters (alpha and/or numeric) by which the physical port will be recognized by the system. Multiple descriptions are needed if multiple ports will be used. Physical ports are configured within the source context and are used to bind logical R-P interfaces.
Gateway IP address	Used when configuring static routes from the R-P interface(s) to a specific network.
PDSN service Configuration	
PDSN service name	This is an identification string between 1 and 63 characters (alpha and/or numeric) by which the PDSN service will be recognized by the system. Multiple names are needed if multiple PDSN services will be used. PDSN services are configured in the source context.

Required Information	Description
UDP port number for R-P traffic	Specifies the port used by the PDSN service and the PCF for communications. The UDP port number and can be any integer value between 1 and 65535. The default value is 699.
Authentication protocols used	Specifies how the system handles authentication: using a protocol (such as CHAP, PAP, or MSCHAP), or not requiring any authentication.
Domain alias for NAI-construction	Specifies a context name for the system to use to provide accounting functionality for a subscriber session. This parameter is needed only if the system is configured to support no authentication.

Required Information	Description
Security Parameter Index Information	<p>PCF IP address:</p> <p>Specifies the IP address of the PCF that the PDSN service will be communicating with. The PDSN service allows the creation of a security profile that can be associated with a particular PCF.</p> <p>Multiple IP addresses are needed if the PDSN service will be communicating with multiple PCFs.</p> <p>Index:</p> <p>Specifies the shared SPI between the PDSN service and a particular PCF. The SPI can be configured to any integer value between 256 and 4294967295.</p> <p>Multiple SPIs can be configured if the PDSN service is to communicate with multiple PCFs.</p> <p>Secret:</p> <p>Specifies the shared SPI secret between the PDSN service and the PCF. The secret can be between 1 and 127 characters (alpha and/or numeric).</p> <p>An SPI secret is required for each SPI configured.</p> <p>Hash-algorithm:</p> <p>Specifies the algorithm used to hash the SPI and SPI secret. The possible algorithms that can be configured are MD5 per RFC 1321 and keyed-MD5 per RFC 2002. The default is MD5.</p> <p>A hash-algorithm is required for each SPI configured.</p> <p>Replay-protection process:</p> <p>Specifies how protection against replay-attacks is implemented. The possible processes are nonce and timestamp. The default is timestamp with a tolerance of 60 seconds.</p> <p>A replay-protection process is required for each SPI configured.</p>
Subscriber session lifetime	<p>Specifies the time in seconds that an A10 connection can exist before its registration is considered expired.</p> <p>The time is expressed in seconds and can be configured to any integer value between 1 and 65534, or the timer can be disabled to set an infinite lifetime. The default value is 1800 seconds.</p>
AAA Interface Configuration	

Required Information	Description
AAA interface name	<p>This is an identification string between 1 and 79 characters (alpha and/or numeric) by which the interface will be recognized by the system.</p> <p>Multiple names are needed if multiple interfaces will be configured.</p> <p>AAA interfaces will be configured in the source context.</p>
IP address and subnet	<p>These will be assigned to the AAA interface.</p> <p>Multiple addresses and/or subnets are needed if multiple interfaces will be configured.</p>
Physical port number	<p>This specifies the physical port to which the interface will be bound. Ports are identified by the chassis slot number where the line card resides in, followed by the number of the physical connector on the line card. For example, port 17/1 identifies connector number 1 on the card in slot 17.</p> <p>A single physical port can facilitate multiple interfaces.</p>
Physical port description	<p>This is an identification string between 1 and 79 characters (alpha and/or numeric) by which the physical port will be recognized by the system.</p> <p>Multiple descriptions are needed if multiple ports will be used.</p> <p>Physical ports are configured within the source context and are used to bind logical AAA interfaces.</p>
Gateway IP address	<p>Used when configuring static routes from the AAA interface(s) to a specific network.</p>
RADIUS Server Configuration	

Required Information	Description
RADIUS Authentication server	<p data-bbox="963 285 1523 426">IP Address: Specifies the IP address of the RADIUS authentication server the source context will communicate with to provide subscriber authentication functions. Multiple addresses are needed if multiple RADIUS servers will be configured.</p> <p data-bbox="963 520 1523 615">RADIUS authentication servers are configured within the source context. Multiple servers can be configured and each assigned a priority.</p> <p data-bbox="963 646 1523 898">Shared Secret: The shared secret is a string between 1 and 15 characters (alpha and/or numeric) that specifies the key that is exchanged between the RADIUS authentication server and the source context. A shared secret is needed for each configured RADIUS server.</p> <p data-bbox="963 930 1523 1098">UDP Port Number: Specifies the port used by the source context and the RADIUS authentication server for communications. The UDP port number can be any integer value between 1 and 65535. The default value is 1812.</p>

Required Information	Description
RADIUS Accounting server	<p>IP Address:</p> <p>Specifies the IP address of the RADIUS accounting server that the source context will communicate with to provide subscriber accounting functions.</p> <p>Multiple addresses are needed if multiple RADIUS servers will be configured.</p> <p>RADIUS accounting servers are configured within the source context. Multiple servers can be configured and each assigned a priority.</p> <p>Shared Secret:</p> <p>The shared secret is a string between 1 and 15 characters (alpha and/or numeric) that specifies the key that is exchanged between the RADIUS accounting server and the source context.</p> <p>A shared secret is needed for each configured RADIUS server.</p> <p>UDP Port Number:</p> <p>Specifies the port used by the source context and the RADIUS Accounting server for communications. The UDP port number can be any integer value between 1 and 65535. The default value is 1813.</p>
RADIUS attribute NAS Identifier	Specifies the name by which the source context will be identified in the Access-Request message(s) it sends to the RADIUS server. The name must be between 1 and 32 alpha and/or numeric characters and is case sensitive.
RADIUS NAS IP address	Specifies the IP address of the source context's AAA interface. A secondary IP address interface can optionally be configured.
Default Subscriber Configuration	
"Default" subscriber's IP context name	<p>Specifies the name of the egress context on the system that facilitates the PDN ports.</p> <p>Important For this configuration, the IP context name should be identical to the name of the destination context.</p>

Destination Context Configuration

The following table lists the information that is required to configure the destination context.

Table 9: Required Information for Destination Context Configuration

Required Information	Description
Destination context name	<p>This is an identification string between 1 and 79 characters (alpha and/or numeric) by which the destination context will be recognized by the system.</p> <p>Important For this configuration, the destination context name should not match the domain name of a specific domain.</p>
PDN Interface Configuration	
PDN interface name	<p>This is an identification string between 1 and 79 characters (alpha and/or numeric) by which the interface will be recognized by the system.</p> <p>Multiple names are needed if multiple interfaces will be configured.</p> <p>PDN interfaces are configured in the destination context.</p>
IP address and subnet	<p>These will be assigned to the PDN interface.</p> <p>Multiple addresses and/or subnets are needed if multiple interfaces will be configured.</p>
Physical port number	<p>This specifies the physical port to which the interface will be bound. Ports are identified by the chassis slot number where the line card resides in, followed by the number of the physical connector on the line card. For example, port 17/1 identifies connector number 1 on the card in slot 17.</p> <p>A single physical port can facilitate multiple interfaces.</p>
Physical port description(s)	<p>This is an identification string between 1 and 79 characters (alpha and/or numeric) by which the physical port will be recognized by the system.</p> <p>Multiple descriptions will be needed if multiple ports will be used.</p> <p>Physical ports are configured within the destination context and are used to bind logical PDN interfaces.</p>
Gateway IP address(es)	Used when configuring static routes from the PDN interface(s) to a specific network.
IP Address Pool Configuration (optional)	

Required Information	Description
IP address pool name(s)	If IP address pools will be configured in the destination context(s), names or identifiers will be needed for them. The pool name can be between 1 and 31 alpha and/or numeric characters and is case sensitive.
IP pool addresses	An initial address and a subnet, or a starting address and an ending address, are required for each configured pool. The pool will then consist of every possible address within the subnet, or all addresses from the starting address to the ending address. The pool can be configured as public, private, or static.

How This Configuration Works

The following figure and the text that follows describe how this configuration with a single source and destination context would be used by the system to process a Simple IP data call.

Figure 14: Call Processing Using a Single Source and Destination Context

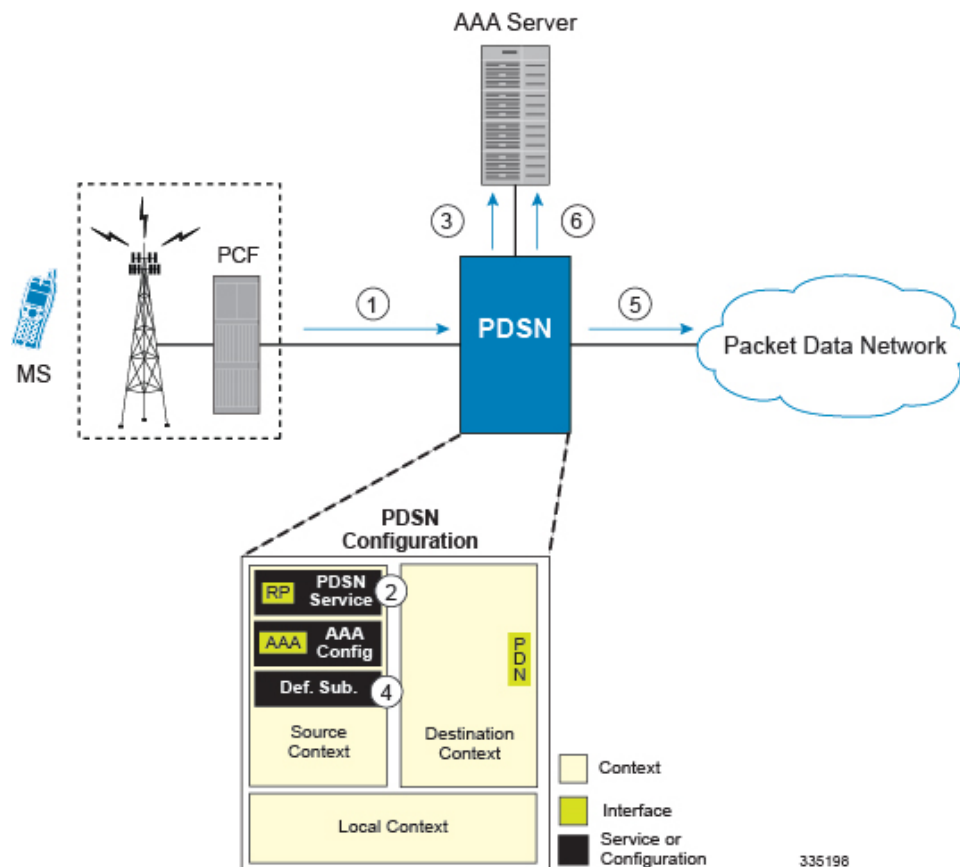

1. A subscriber session from the PCF is received by the PDSN service over the R-P interface.

2. The PDSN service determines which context to use in providing AAA functionality for the session. This process is described in the How the System Selects Contexts section located in the Understanding the System Operation and Configuration chapter of the *System Administration Guide*.

For this example, the result of this process is that PDSN service determined that AAA functionality should be provided by the *Source* context.

3. The system communicates with the AAA server specified in the *Source* context's AAA configuration to authenticate the subscriber.
4. Upon successful authentication, the system determines which egress context to use for the subscriber session. This process is described in the How the System Selects Contexts section located in the Understanding the System Operation and Configuration chapter of the *System Administration Guide*.

The system determines that the egress context is the destination context based on the configuration of either the *Default* subscriber's *ip-context* name or from the *SN-VPN-NAME* or *SNI-VPN-NAME* attributes that is configured in the subscriber's RADIUS profile.

5. Data traffic for the subscriber session is routed through the PDN interface in the *Destination* context.
6. Accounting information for the session is sent to the AAA server over the AAA interface.

Example 2: Simple IP Using a Single Source Context and Multiple Outsourced Destination Contexts

The system allows the wireless carrier to easily generate additional revenue by providing the ability to configure separate contexts that can then be leased or outsourced to various enterprises or ISPs, each having a specific domain.

In order to support multiple outsourced domains, the system must first be configured with at least one source context and multiple destination contexts as shown in the following figure. The AAA servers could be owned/maintained by either the carrier or the domain. If they are owned by the domain, the carrier will have to receive the AAA information via proxy.

Figure 15: Simple IP Support Using a Single Source Context and Multiple Outsourced Destination Contexts

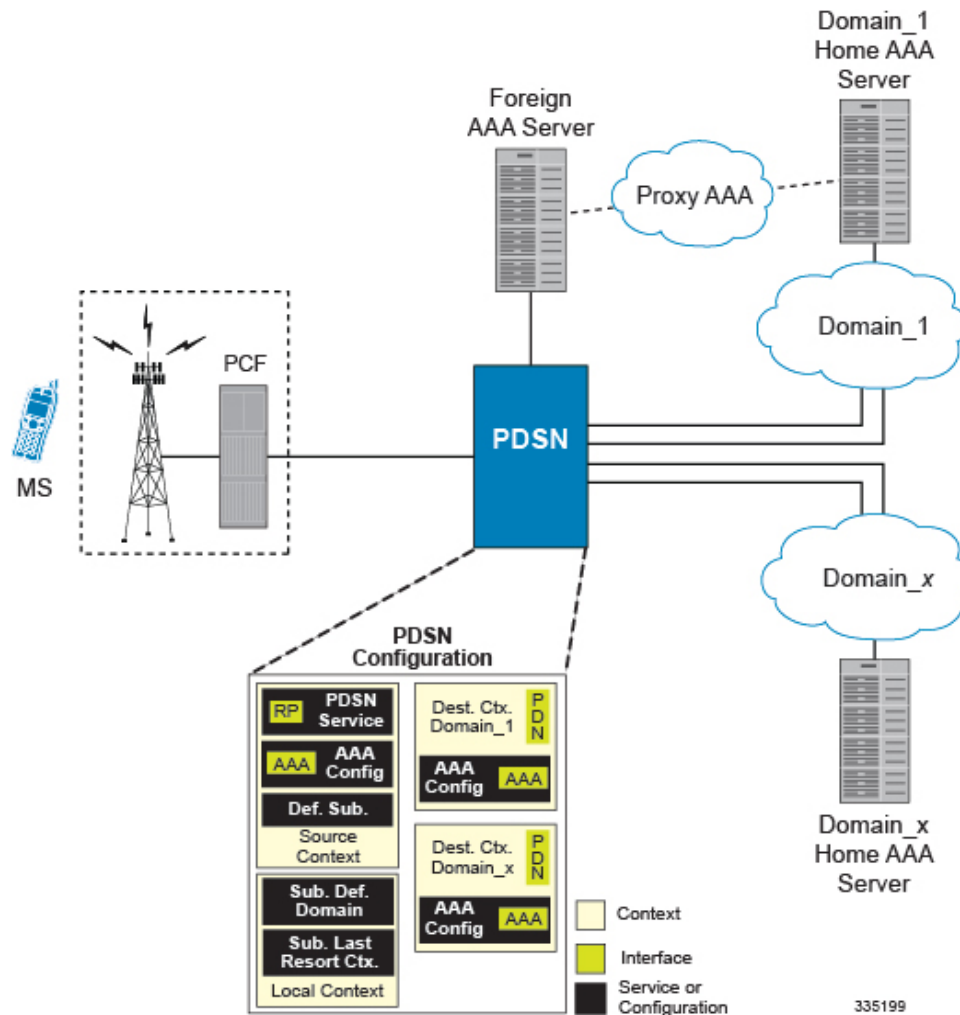

The source context will facilitate the PDSN service(s), and the R-P interface(s). The source context will also be configured with AAA interface(s) to provide AAA functionality for subscriber sessions. The destination contexts will each be configured to facilitate PDN interfaces. In addition, because each of the destination contexts can be outsourced to different domains, they will also be configured with AAA interface(s) to provide AAA functionality for that domain.

In addition to the source and destination contexts, there are additional system-level AAA parameters that must be configured.

Information Required

Prior to configuring the system as shown in this example, there is a minimum amount of information required. The following sections describe the information required to configure the source and destination contexts.

Source Context Configuration

The following table lists the information that is required to configure the source context.

Table 10: Required Information for Source Context Configuration

Required Information	Description
Source context name	This is an identification string between 1 and 79 characters (alpha and/or numeric) by which the source context will be recognized by the system.
R-P Interface Configuration	
R-P interface name	This is an identification string between 1 and 79 characters (alpha and/or numeric) by which the interface will be recognized by the system. Multiple names are needed if multiple interfaces will be configured. R-P interfaces are configured in the source context.
IP address and subnet	These will be assigned to the R-P interface. Multiple addresses and/or subnets are needed if multiple interfaces will be configured.
Physical port number	This specifies the physical port to which the interface will be bound. Ports are identified by the chassis slot number where the line card resides in, followed by the number of the physical connector on the line card. For example, port 17/1 identifies connector number 1 on the card in slot 17. A single physical port can facilitate multiple interfaces.
Physical port description	This is an identification string between 1 and 79 characters (alpha and/or numeric) by which the physical port will be recognized by the system. Multiple descriptions are needed if multiple ports will be used. Physical ports are configured within the source context and are used to bind logical R-P interfaces.
Gateway IP address	Used when configuring static routes from the R-P interface(s) to a specific network.
PDSN service Configuration	
PDSN service name	This is an identification string between 1 and 63 characters (alpha and/or numeric) by which the PDSN service will be recognized by the system. Multiple names are needed if multiple PDSN services will be used. PDSN services are configured in the source context.

Required Information	Description
UDP port number for R-P traffic	Specifies the port used by the PDSN service and the PCF for communications. The UDP port number and can be any integer value between 1 and 65535. The default value is 699.
Authentication protocols used	Specifies how the system handles authentication: using a protocol (such as CHAP, PAP, or MSCHAP), or not requiring any authentication.
Domain alias for NAI-construction	Specifies a context name for the system to use to provide accounting functionality for a subscriber session. This parameter is needed only if the system is configured to support no authentication.

Required Information	Description
Security Parameter Index Information	<p>PCF IP address:</p> <p>Specifies the IP address of the PCF that the PDSN service will be communicating with. The PDSN service allows the creation of a security profile that can be associated with a particular PCF.</p> <p>Multiple IP addresses are needed if the PDSN service will be communicating with multiple PCFs.</p> <p>Index:</p> <p>Specifies the shared SPI between the PDSN service and a particular PCF. The SPI can be configured to any integer value between 256 and 4294967295.</p> <p>Multiple SPIs can be configured if the PDSN service is to communicate with multiple PCFs.</p> <p>Secret:</p> <p>Specifies the shared SPI secret between the PDSN service and the PCF. The secret can be between 1 and 127 characters (alpha and/or numeric).</p> <p>An SPI secret is required for each SPI configured.</p> <p>Hash-algorithm:</p> <p>Specifies the algorithm used to hash the SPI and SPI secret. The possible algorithms that can be configured are MD5 per RFC 1321 and keyed-MD5 per RFC 2002. The default is MD5.</p> <p>A hash-algorithm is required for each SPI configured.</p> <p>Replay-protection process:</p> <p>Specifies how protection against replay-attacks is implemented. The possible processes are nonce and timestamp. The default is timestamp with a tolerance of 60 seconds.</p> <p>A replay-protection process is required for each SPI configured.</p>
Subscriber session lifetime	<p>Specifies the time in seconds that an A10 connection can exist before its registration is considered expired.</p> <p>The time is expressed in seconds and can be configured to any integer value between 1 and 65534, or the timer can be disabled to set an infinite lifetime. The default value is 1800 seconds.</p>
AAA Interface Configuration	

Required Information	Description
AAA interface name	<p>This is an identification string between 1 and 79 characters (alpha and/or numeric) by which the interface will be recognized by the system.</p> <p>Multiple names are needed if multiple interfaces will be configured.</p> <p>AAA interfaces will be configured in the source context.</p>
IP address and subnet	<p>These will be assigned to the AAA interface.</p> <p>Multiple addresses and/or subnets are needed if multiple interfaces will be configured.</p>
Physical port number	<p>This specifies the physical port to which the interface will be bound. Ports are identified by the chassis slot number where the line card resides in, followed by the number of the physical connector on the line card. For example, port 17/1 identifies connector number 1 on the card in slot 17.</p> <p>A single physical port can facilitate multiple interfaces.</p>
Physical port description	<p>This is an identification string between 1 and 79 characters (alpha and/or numeric) by which the physical port will be recognized by the system.</p> <p>Multiple descriptions are needed if multiple ports will be used.</p> <p>Physical ports are configured within the source context and are used to bind logical AAA interfaces.</p>
Gateway IP address	<p>Used when configuring static routes from the AAA interface(s) to a specific network.</p>
RADIUS Server Configuration	

Required Information	Description
RADIUS Authentication server	<p data-bbox="963 283 1523 426">IP Address: Specifies the IP address of the RADIUS authentication server the source context will communicate with to provide subscriber authentication functions. Multiple addresses are needed if multiple RADIUS servers will be configured.</p> <p data-bbox="963 520 1523 615">RADIUS authentication servers are configured within the source context. Multiple servers can be configured and each assigned a priority.</p> <p data-bbox="963 642 1523 894">Shared Secret: The shared secret is a string between 1 and 15 characters (alpha and/or numeric) that specifies the key that is exchanged between the RADIUS authentication server and the source context. A shared secret is needed for each configured RADIUS server.</p> <p data-bbox="963 921 1523 1100">UDP Port Number: Specifies the port used by the source context and the RADIUS authentication server for communications. The UDP port number can be any integer value between 1 and 65535. The default value is 1812.</p>

Required Information	Description
RADIUS Accounting server	<p>IP Address:</p> <p>Specifies the IP address of the RADIUS accounting server that the source context will communicate with to provide subscriber accounting functions.</p> <p>Multiple addresses are needed if multiple RADIUS servers will be configured.</p> <p>RADIUS accounting servers are configured within the source context. Multiple servers can be configured and each assigned a priority.</p> <p>Shared Secret:</p> <p>The shared secret is a string between 1 and 15 characters (alpha and/or numeric) that specifies the key that is exchanged between the RADIUS accounting server and the source context.</p> <p>A shared secret is needed for each configured RADIUS server.</p> <p>UDP Port Number:</p> <p>Specifies the port used by the source context and the RADIUS Accounting server for communications. The UDP port number can be any integer value between 1 and 65535. The default value is 1813.</p>
RADIUS attribute NAS Identifier	Specifies the name by which the source context will be identified in the Access-Request message(s) it sends to the RADIUS server. The name must be between 1 and 32 alpha and/or numeric characters and is case sensitive.
RADIUS NAS IP address	Specifies the IP address of the source context's AAA interface. A secondary IP address interface can optionally be configured.
Default Subscriber Configuration	
"Default" subscriber's IP context name	<p>Specifies the name of the egress context on the system that facilitates the PDN ports.</p> <p>Important For this configuration, the IP context name should be identical to the name of the destination context.</p>

Destination Context Configuration

The following table lists the information that is required to configure the destination context.

Table 11: Required Information for Destination Context Configuration

Required Information	Description
Destination context name	<p>This is an identification string between 1 and 79 characters (alpha and/or numeric) by which the destination context will be recognized by the system.</p> <p>Important For this configuration, the destination context name should not match the domain name of a specific domain.</p>
PDN Interface Configuration	
PDN interface name	<p>This is an identification string between 1 and 79 characters (alpha and/or numeric) by which the interface will be recognized by the system.</p> <p>Multiple names are needed if multiple interfaces will be configured.</p> <p>PDN interfaces are configured in the destination context.</p>
IP address and subnet	<p>These will be assigned to the PDN interface.</p> <p>Multiple addresses and/or subnets are needed if multiple interfaces will be configured.</p>
Physical port number	<p>This specifies the physical port to which the interface will be bound. Ports are identified by the chassis slot number where the line card resides in, followed by the number of the physical connector on the line card. For example, port 17/1 identifies connector number 1 on the card in slot 17.</p> <p>A single physical port can facilitate multiple interfaces.</p>
Physical port description(s)	<p>This is an identification string between 1 and 79 characters (alpha and/or numeric) by which the physical port will be recognized by the system.</p> <p>Multiple descriptions will be needed if multiple ports will be used.</p> <p>Physical ports are configured within the destination context and are used to bind logical PDN interfaces.</p>
Gateway IP address(es)	Used when configuring static routes from the PDN interface(s) to a specific network.
IP Address Pool Configuration (optional)	

Required Information	Description
IP address pool name(s)	If IP address pools will be configured in the destination context(s), names or identifiers will be needed for them. The pool name can be between 1 and 31 alpha and/or numeric characters and is case sensitive.
IP pool addresses	An initial address and a subnet, or a starting address and an ending address, are required for each configured pool. The pool will then consist of every possible address within the subnet, or all addresses from the starting address to the ending address. The pool can be configured as public, private, or static.
AAA Interface Configuration	
AAA interface name	This is an identification string between 1 and 79 characters (alpha and/or numeric) by which the interface will be recognized by the system. Multiple names are needed if multiple interfaces will be configured. AAA interfaces will be configured in the source context.
IP address and subnet	These will be assigned to the AAA interface. Multiple addresses and/or subnets are needed if multiple interfaces will be configured.
Physical port number	This specifies the physical port to which the interface will be bound. Ports are identified by the chassis slot number where the line card resides in, followed by the number of the physical connector on the line card. For example, port 17/1 identifies connector number 1 on the card in slot 17. A single physical port can facilitate multiple interfaces.
Physical port description	This is an identification string between 1 and 79 characters (alpha and/or numeric) by which the physical port will be recognized by the system. Multiple descriptions are needed if multiple ports will be used. Physical ports are configured within the source context and are used to bind logical AAA interfaces.
Gateway IP address	Used when configuring static routes from the AAA interface(s) to a specific network.
RADIUS Server Configuration	

Required Information	Description
RADIUS Authentication server	<p data-bbox="963 283 1524 422">IP Address: Specifies the IP address of the RADIUS authentication server the source context will communicate with to provide subscriber authentication functions. Multiple addresses are needed if multiple RADIUS servers will be configured.</p> <p data-bbox="963 520 1524 615">RADIUS authentication servers are configured within the source context. Multiple servers can be configured and each assigned a priority.</p> <p data-bbox="963 642 1524 890">Shared Secret: The shared secret is a string between 1 and 15 characters (alpha and/or numeric) that specifies the key that is exchanged between the RADIUS authentication server and the source context. A shared secret is needed for each configured RADIUS server.</p> <p data-bbox="963 917 1524 1100">UDP Port Number: Specifies the port used by the source context and the RADIUS authentication server for communications. The UDP port number can be any integer value between 1 and 65535. The default value is 1812.</p>

Required Information	Description
RADIUS Accounting server	<p>IP Address:</p> <p>Specifies the IP address of the RADIUS accounting server that the source context will communicate with to provide subscriber accounting functions.</p> <p>Multiple addresses are needed if multiple RADIUS servers will be configured.</p> <p>RADIUS accounting servers are configured within the source context. Multiple servers can be configured and each assigned a priority.</p>
	<p>Shared Secret:</p> <p>The shared secret is a string between 1 and 15 characters (alpha and/or numeric) that specifies the key that is exchanged between the RADIUS accounting server and the source context.</p> <p>A shared secret is needed for each configured RADIUS server.</p>
	<p>UDP Port Number:</p> <p>Specifies the port used by the source context and the RADIUS Accounting server for communications. The UDP port number can be any integer value between 1 and 65535. The default value is 1813.</p>
RADIUS attribute NAS Identifier	<p>Specifies the name by which the source context will be identified in the Access-Request message(s) it sends to the RADIUS server. The name must be between 1 and 32 alpha and/or numeric characters and is case sensitive.</p>
RADIUS NAS IP address	<p>Specifies the IP address of the source context's AAA interface. A secondary IP address interface can optionally be configured.</p>

System-Level AAA Configuration

The following table lists the information required to configure the system-level AAA parameters.

Table 12: Required Information for System-Level AAA Configuration

Required Information	Description
Subscriber default domain name	<p>Specifies the name of a context that can provide AAA functions in the event that the domain-part of the username is missing or poorly formed.</p> <p>This parameter will be applied to all subscribers if their domain can not be determined from their username regardless of what domain they are trying to access.</p> <p>Important The default domain name can be the same as the source context.</p>
Subscriber Last-resort context	<p>Specifies the name of a context that can provide AAA functions in the event that the domain-part of the username was present but does not match the name of a configured destination context.</p> <p>This parameter will be applied to all subscribers if their specified domain does not match a configured destination context regardless of what domain they are trying to access.</p> <p>Important The last-resort context name can be the same as the source context.</p>

Required Information	Description
Subscriber username format	<p>Specifies the format of subscriber usernames as to whether or not the username or domain is specified first and the character that separates them. The possible separator characters are:</p> <ul style="list-style-type: none"> • @ • % • - • \ • # • / <p>Up to six username formats can be specified. The default is <i>username @</i>.</p> <p>Important The username string is searched from right to left for the separator character. Therefore, if there is one or more separator characters in the string, only the first one that is recognized is considered the actual separator. For example, if the default username format was used, then for the username string <i>user1@enterprise@isp1</i>, the system resolves to the username <i>user1@enterprise</i> with domain <i>isp1</i>.</p>

How This Configuration Works

The following figure and the text that follows describe how this configuration with a single source and destination context would be used by the system to process a Simple IP data call.

Figure 16: Call Processing Using a Single Source and Destination Context

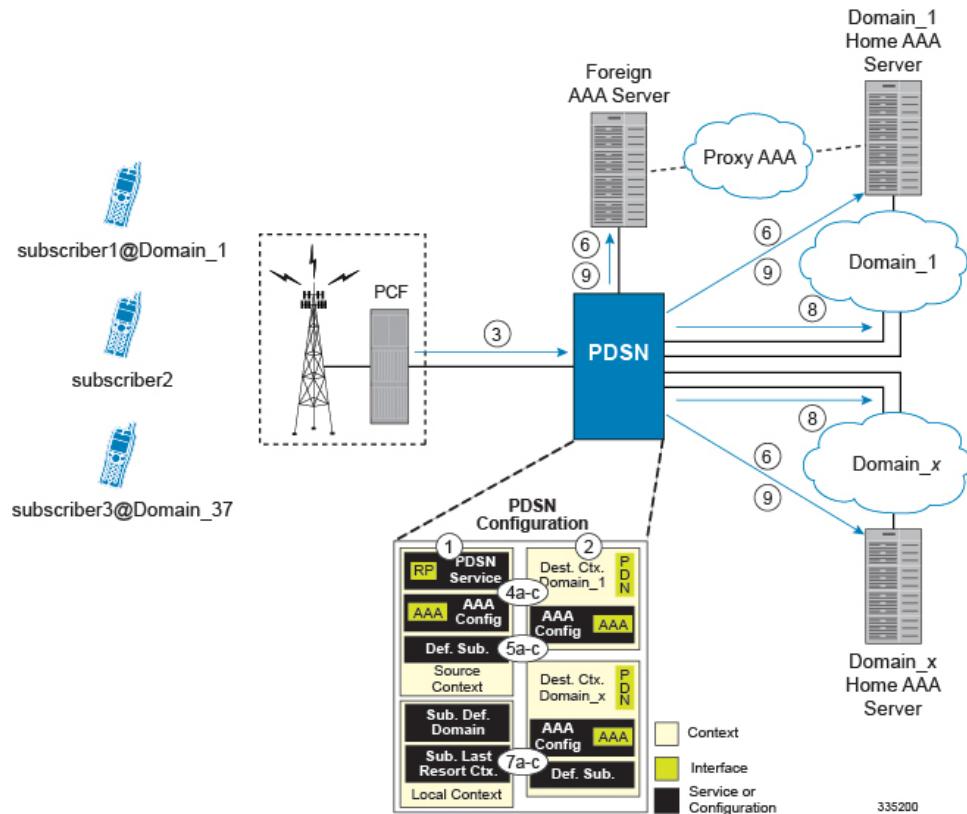

1. The system-level AAA settings were configured as follows: Default subscriber domain name = DomainxSubscriber username format = username @No subscriber last-resort context name was configured. The IP context names for the Default subscriber were configured as follows: Within the Source context, the IP context name was configured as Domainx. Within the Domainx context, the IP context name was configured as Domainx. Sessions are received by the PDSN service from the PCF over the R-P interface for subscriber1@Domain1, subscriber2, and subscriber3@Domain37. The PDSN service attempts to determine the domain names for each session. For subscriber1, the PDSN service determines that a domain name is present and is Domain1. For subscriber2, the PDSN service determines that no domain name is present. For subscriber3, the PDSN service determines that a domain name is present and is Domain37. The PDSN service determines which context to use to provide AAA functionality for the session. This process is described in the How the System Selects Contexts section located in the Understanding the System Operation and Configuration chapter of the System Administration Guide. For subscriber1, the PDSN service determines that a context is configured with a name that matches the domain name specified in the username string (Domain1). Therefore, Domain1 is used. For subscriber2, the PDSN service determines that Domainx was configured as the subscriber default domain name. Therefore, Domainx was used. For subscriber3, the PDSN service determines that no context was configured that matched the domain name specified in the username string (Domain37). Because no subscriber last-resort context name is configured, the source context is used. The system then communicates with the AAA servers specified in each of the selected context's AAA configuration to authenticate the subscriber. Upon successful authentication of all three subscribers, the PDSN service determines which destination context to use for each of the subscriber sessions. This process is described in the How the System Selects Contexts section located in the Understanding the System Operation and Configuration chapter of the System Administration Guide. For subscriber1, the PDSN service receives the SN-VPN-NAME or SN1-VPN-NAME attribute equal to Domain1 as part of the authentication accept message from the AAA server on Domain1's network.

Therefore, Domain1 is used as the destination context. For subscriber2, the PDSN service determined that the SN-VPN-NAME or SN1-VPN-NAME attribute was not returned with the Authentication Accept response, and determines the subscriber IP context name configured for the Default subscriber within the Domainx context. Because this parameter is configured to Domainx, the Domainx context will be used as the destination context. For subscriber3, the PDSN service determines that the SN-VPN-NAME or SN1-VPN-NAME attribute was not returned with the Authentication Accept response, and determined the Default subscriber IP context name configured within the Source context. Because this parameter is configured to Domainx, the Domainx context is used as the destination context. Data traffic for the subscriber session is routed through the PDN interface in each subscriber's destination context. Accounting messages for the session are sent to the AAA servers over the AAA interfaces

A subscriber session from the PCF is received by the PDSN service over the R-P interface.

2. The PDSN service determines which context to use in providing AAA functionality for the session. This process is described in the How the System Selects Contexts section located in the Understanding the System Operation and Configuration chapter of the *System Administration Guide*.

For this example, the result of this process is that PDSN service determined that AAA functionality should be provided by the *Source* context.

3. The system communicates with the AAA server specified in the *Source* context's AAA configuration to authenticate the subscriber.
4. Upon successful authentication, the system determines which egress context to use for the subscriber session. This process is described in the How the System Selects Contexts section located in the Understanding the System Operation and Configuration chapter of the *System Administration Guide*.

The system determines that the egress context is the destination context based on the configuration of either the *Default* subscriber's *ip-context* name or from the *SN-VPN-NAME* or *SN1-VPN-NAME* attributes that is configured in the subscriber's RADIUS profile.

5. Data traffic for the subscriber session is routed through the PDN interface in the *Destination* context.
 6. Accounting information for the session is sent to the AAA server over the AAA interface.
1. The system-level AAA settings were configured as follows:
 - Default subscriber domain name = Domainx
 - Subscriber username format = username @
 - No subscriber last-resort context name was configured.
 2. The IP context names for the Default subscriber were configured as follows:
 - Within the Source context, the IP context name was configured as Domainx.
 - Within the Domainx context, the IP context name was configured as Domainx.
 3. Sessions are received by the PDSN service from the PCF over the R-P interface for subscriber1@Domain1, subscriber2, and subscriber3@Domain37.
 4. The PDSN service attempts to determine the domain names for each session.
 - For subscriber1, the PDSN service determines that a domain name is present and is Domain1.
 - For subscriber2, the PDSN service determines that no domain name is present.

- For subscriber3, the PDSN service determines that a domain name is present and is Domain37.
5. The PDSN service determines which context to use to provide AAA functionality for the session. This process is described in the How the System Selects Contexts section located in the Understanding the System Operation and Configuration chapter of the System Administration Guide.
 - For subscriber1, the PDSN service determines that a context is configured with a name that matches the domain name specified in the username string (Domain1). Therefore, Domain1 is used.
 - For subscriber2, the PDSN service determines that Domainx was configured as the subscriber default domain name. Therefore, Domainx was used.
 - For subscriber3, the PDSN service determines that no context was configured that matched the domain name specified in the username string (Domain37). Because no subscriber last-resort context name is configured, the source context is used.
 6. The system then communicates with the AAA servers specified in each of the selected context's AAA configuration to authenticate the subscriber.
 7. Upon successful authentication of all three subscribers, the PDSN service determines which destination context to use for each of the subscriber sessions. This process is described in the How the System Selects Contexts section located in the Understanding the System Operation and Configuration chapter of the System Administration Guide.
 - For subscriber1, the PDSN service receives the SN-VPN-NAME or SN1-VPN-NAME attribute equal to Domain1 as part of the authentication accept message from the AAA server on Domain1's network. Therefore, Domain1 is used as the destination context.
 - For subscriber2, the PDSN service determined that the SN-VPN-NAME or SN1-VPN-NAME attribute was not returned with the Authentication Accept response, and determines the subscriber IP context name configured for the Default subscriber within the Domainx context. Because this parameter is configured to Domainx, the Domainx context will be used as the destination context.
 - For subscriber3, the PDSN service determines that the SN-VPN-NAME or SN1-VPN-NAME attribute was not returned with the Authentication Accept response, and determined the Default subscriber IP context name configured within the Source context. Because this parameter is configured to Domainx, the Domainx context is used as the destination context.
 8. Data traffic for the subscriber session is routed through the PDN interface in each subscriber's destination context.
 9. Accounting messages for the session are sent to the AAA servers over the AAA interfaces



CHAPTER 4

Mobile IP Configuration Examples

This chapter provides information for several configuration examples that can be implemented on the system to support Mobile IP (MIP) data services.



Important

This chapter does not discuss the configuration of the local management context. Information about the local management context can be found in Chapter 1 of Command Line Reference. Additionally, when configuring Mobile IP take into account the MIP timing considerations discussed in *MIP Timer Considerations*.

This chapter contains the following topics:

- [Example 1: Mobile IP Support Using the System as a PDSN/FA, on page 91](#)
- [Example 2: Mobile IP Support Using the System as an HA, on page 106](#)
- [Example 3: HA Using a Single Source Context and Multiple Outsourced Destination Contexts, on page 116](#)

Example 1: Mobile IP Support Using the System as a PDSN/FA

The system supports both Simple and Mobile IP. For Mobile IP applications, the system can be configured to perform the function of a Packet Data Serving Node/Foreign Agent (PDSN/FA) and/or a Home Agent (HA). This example describes what is needed for and how the system performs the role of the PDSN/FA. Examples 2 and 3 provide information on using the system to provide HA functionality.

The system's PDSN/FA configuration for Mobile IP applications is best addressed with three contexts (one source, one AAA, and one Mobile IP destination) configured as shown in the figure below.



Important

A fourth context that serves as a destination context must also be configured if Reverse Tunneling is disabled in the FA service configuration. Reverse Tunneling is enabled by default.

The source context will facilitate the PDSN service(s), and the R-P interfaces. The AAA context will be configured to provide foreign AAA functionality for subscriber sessions and facilitate the AAA interfaces. The MIP destination context will facilitate the FA service(s) and the Pi interface(s) from the PDSN/FA to the HA.

Information Required

The optional destination context will allow the routing of data from the mobile node to the packet data network by facilitating a packet data network (PDN) interface. This context will be used only if reverse tunneling was disabled.

Figure 17: Mobile IP Support using the system as a PDSN/FA

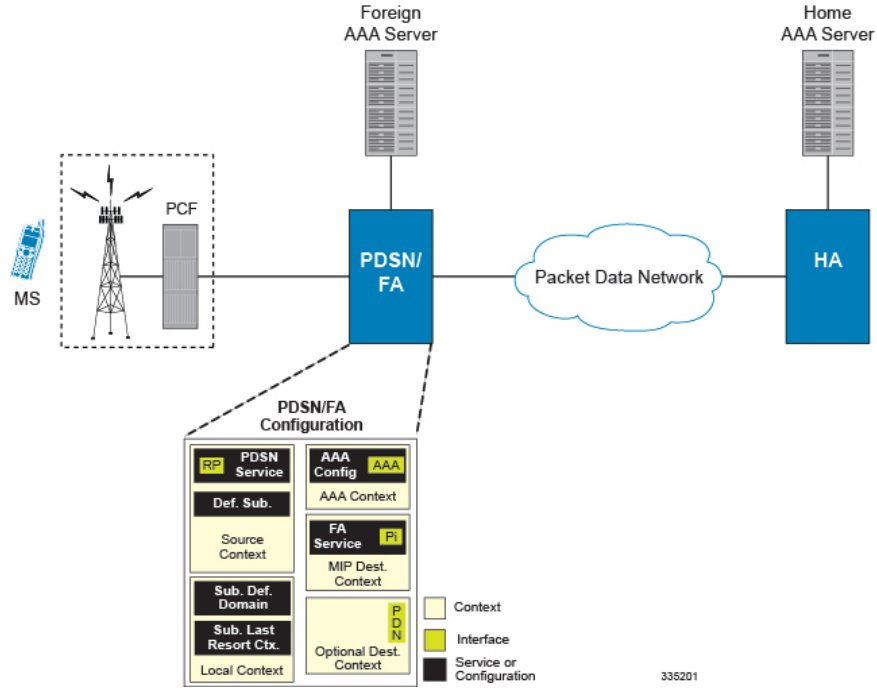

Information Required

Prior to configuring the system as shown in this example, there is a minimum amount of information required. The following sections describe the information required to configure the source and destination contexts.

Source Context Configuration

The following table lists the information that is required to configure the source context.

Table 13: Required Information for Source Context Configuration

Required Information	Description
Source context name	This is an identification string between 1 and 79 characters (alpha and/or numeric) by which the source context will be recognized by the system.
R-P Interface Configuration	

Required Information	Description
R-P interface name	<p>This is an identification string between 1 and 79 characters (alpha and/or numeric) by which the interface will be recognized by the system.</p> <p>Multiple names are needed if multiple interfaces will be configured.</p> <p>R-P interfaces are configured in the source context.</p>
IP address and subnet	<p>These will be assigned to the R-P interface.</p> <p>Multiple addresses and/or subnets are needed if multiple interfaces will be configured.</p>
Physical port number	<p>This specifies the physical port to which the interface will be bound. Ports are identified by the chassis slot number where the line card resides in, followed by the number of the physical connector on the line card. For example, port 17/1 identifies connector number 1 on the card in slot 17.</p> <p>A single physical port can facilitate multiple interfaces.</p>
Physical port description	<p>This is an identification string between 1 and 79 characters (alpha and/or numeric) by which the physical port will be recognized by the system.</p> <p>Multiple descriptions are needed if using multiple ports.</p> <p>Physical ports are configured within the source context and are used to bind logical R-P interfaces.</p>
Gateway IP address	<p>Used when configuring static routes from the R-P interface(s) to a specific network.</p>
PDSN service Configuration	
PDSN service name	<p>This is an identification string between 1 and 63 characters (alpha and/or numeric) by which the PDSN service will be recognized by the system.</p> <p>Multiple names are needed if using multiple PDSN services.</p> <p>PDSN services are configured in the source context.</p>
UDP port number for R-P traffic	<p>Specifies the port used by the PDSN service and the PCF for communications. The UDP port number and can be any integer value between 1 and 65535. The default value is 699.</p>

Required Information	Description
Authentication protocols used	Specifies how the system handles authentication: using a protocol (such as CHAP, PAP, or MSCHAP), or not requiring any authentication.
Domain alias for NAI-construction	Specifies a context name for the system to use to provide accounting functionality for a subscriber session. This parameter is needed only if the system is configured to support no authentication.
Security Parameter Index Information	<p>PCF IP address:</p> <p>Specifies the IP address of the PCF that the PDSN service will be communicating with. The PDSN service allows the creation of a security profile that can be associated with a particular PCF.</p> <p>Multiple IP addresses are needed if the PDSN service is to communicate with multiple PCFs.</p> <p>Index:</p> <p>Specifies the shared SPI between the PDSN service and a particular PCF. The SPI can be configured to any integer value between 256 and 4294967295.</p> <p>Configure multiple SPIs if the PDSN service is to communicate with multiple PCFs.</p> <p>Secret:</p> <p>Specifies the shared SPI secret between the PDSN service and the PCF. The secret can be between 1 and 127 characters (alpha and/or numeric).</p> <p>An SPI secret is required for each SPI configured.</p> <p>Hash-algorithm:</p> <p>Specifies the algorithm used to hash the SPI and SPI secret. The possible algorithms that can be configured are MD5 per RFC 1321 and keyed-MD5 per RFC 2002. The default is MD5.</p> <p>A hash-algorithm is required for each SPI configured.</p> <p>Replay-protection process:</p> <p>Specifies how protection against replay-attacks is implemented. The possible processes are nonce and timestamp. The default is timestamp with a tolerance of 60 seconds.</p> <p>A replay-protection process is required for each SPI configured.</p>

Required Information	Description
Subscriber session lifetime	Specifies the time in seconds that an A10 connection can exist before its registration is considered expired. The time is expressed in seconds and can be configured to any integer value between 1 and 65534, or the timer can be disabled to set an infinite lifetime. The default value is 1800 seconds.
Mobile IP FA context name	Specifies the name of the context in which the FA service is configured.

AAA Context Configuration

The following table lists the information that is required to configure the AAA context.

Table 14: Required Information for AAA Context Configuration

Required Information	Description
AAA context name	This is an identification string between 1 and 79 characters (alpha and/or numeric) by which the AAA context will be recognized by the system. Important If a separate system is used to provide HA functionality, the AAA context name should match the name of the context in which the AAA functionality is configured on the HA machine.
AAA Interface Configuration	
AAA interface name	This is an identification string between 1 and 79 characters (alpha and/or numeric) by which the interface will be recognized by the system. Multiple names are needed if multiple interfaces will be configured. AAA interfaces will be configured in the source context.
IP address and subnet	These will be assigned to the AAA interface. Multiple addresses and/or subnets are needed if multiple interfaces will be configured.

Required Information	Description
Physical port number	<p>This specifies the physical port to which the interface will be bound. Ports are identified by the chassis slot number where the line card resides in, followed by the number of the physical connector on the line card. For example, port 17/1 identifies connector number 1 on the card in slot 17.</p> <p>A single physical port can facilitate multiple interfaces.</p>
Physical port description	<p>This is an identification string between 1 and 79 characters (alpha and/or numeric) by which the physical port will be recognized by the system.</p> <p>Multiple descriptions are needed if multiple ports will be used.</p> <p>Physical ports are configured within the destination context and are used to bind logical AAA interfaces.</p>
Gateway IP address(es)	Used when configuring static routes from the AAA interface(s) to a specific network.
Foreign RADIUS Server Configuration	

Required Information	Description
Foreign RADIUS Authentication server	<p>IP Address:</p> <p>Specifies the IP address of the foreign RADIUS accounting server that the source context will communicate with to provide subscriber accounting functions.</p> <p>Multiple addresses are needed if configuring multiple RADIUS servers.</p> <p>Foreign RADIUS accounting servers are configured within the source context. Multiple servers can be configured and each assigned a priority.</p> <p>Shared Secret:</p> <p>The shared secret is a string between 1 and 15 characters (alpha and/or numeric) that specifies the key exchanged between the RADIUS accounting server and the source context.</p> <p>A shared secret is needed for each configured RADIUS server.</p> <p>UDP Port Number:</p> <p>Specifies the port used by the source context and the foreign RADIUS Accounting server for communications. The UDP port number can be any integer value between 1 and 65535. The default value is 1812.</p>

Required Information	Description
Foreign RADIUS Accounting server	<p>IP Address:</p> <p>Specifies the IP address of the foreign RADIUS accounting server that the source context will communicate with to provide subscriber accounting functions.</p> <p>Multiple addresses are needed if configuring multiple RADIUS servers.</p> <p>Foreign RADIUS accounting servers are configured within the source context. Multiple servers can be configured and each assigned a priority.</p> <p>Shared Secret:</p> <p>The shared secret is a string between 1 and 15 characters (alpha and/or numeric) that specifies the key exchanged between the RADIUS accounting server and the source context.</p> <p>A shared secret is needed for each configured RADIUS server.</p> <p>UDP Port Number:</p> <p>Specifies the port used by the source context and the foreign RADIUS Accounting server for communications. The UDP port number can be any integer value between 1 and 65535. The default value is 1813.</p>
RADIUS attribute NAS Identifier	<p>Specifies the name by which the source context will be identified in the Access-Request message(s) it sends to the foreign RADIUS server. The name must be between 1 and 32 alpha and/or numeric characters and is case sensitive.</p>
RADIUS NAS IP address	<p>Specifies the IP address of the source context's AAA interface. A secondary address can be optionally configured.</p>

Mobile IP Destination Context Configuration

The following table lists the information required to configure the destination context.

Table 15: Required Information for Destination Context Configuration

Required Information	Description
Mobile IP destination context name	<p>This is an identification string between 1 and 79 characters (alpha and/or numeric) by which the destination context will be recognized by the system.</p> <p>Important For this configuration, the destination context name should not match the domain name of a specific domain. It should, however, match the name of the context in which the HA service is configured if a separate system is used to provide HA functionality.</p>
Pi Interface Configuration	
Pi interface name	<p>This is an identification string between 1 and 79 characters (alpha and/or numeric) by which the interface will be recognized by the system.</p> <p>Multiple names are needed if multiple interfaces will be configured.</p> <p>Pi interfaces are configured in the destination context.</p>
IP address and subnet	<p>These will be assigned to the Pi interface.</p> <p>Multiple addresses and/or subnets are needed if multiple interfaces will be configured.</p>
Physical port number	<p>This specifies the physical port to which the interface will be bound. Ports are identified by the chassis slot number where the line card resides in, followed by the number of the physical connector on the line card. For example, port 17/1 identifies connector number 1 on the card in slot 17.</p> <p>A single physical port can facilitate multiple interfaces.</p>
Physical port description	<p>This is an identification string between 1 and 79 characters (alpha and/or numeric) by which the physical port will be recognized by the system.</p> <p>Multiple descriptions are needed if multiple ports will be used.</p> <p>Physical ports are configured within the destination context and are used to bind logical Pi interfaces.</p>
Gateway IP address(es)	Used when configuring static routes from the Pi interface(s) to a specific network.
FA Service Configuration	

Required Information	Description
FA service name	<p>This is an identification string between 1 and 63 characters (alpha and/or numeric) by which the FA service will be recognized by the system.</p> <p>Multiple names are needed if multiple FA services will be used.</p> <p>FA services are configured in the destination context.</p>
UDP port number for Mobile IP traffic	<p>Specifies the port used by the FA service and the HA for communications. The UDP port number can be any integer value between 1 and 65535. The default value is 434.</p>
Security Parameter Index (indices) Information	<p>HA IP address:</p> <p>Specifies the IP address of the HAs with which the FA service communicates. The FA service allows the creation of a security profile that can be associated with a particular HA.</p> <p>Index:</p> <p>Specifies the shared SPI between the FA service and a particular HA. The SPI can be configured to any integer value between 256 and 4294967295. Multiple SPIs can be configured if the FA service is to communicate with multiple HAs.</p> <p>Secrets:</p> <p>Specifies the shared SPI secret between the FA service and the HA. The secret can be between 1 and 127 characters (alpha and/or numeric). An SPI secret is required for each SPI configured.</p> <p>Hash-algorithm:</p> <p>Specifies the algorithm used to hash the SPI and SPI secret. The possible algorithms that can be configured are MD5 per RFC 1321 and keyed-MD5 per RFC 2002. The default is hmac-md5.</p> <p>A hash-algorithm is required for each SPI configured.</p>
FA agent advertisement lifetime	<p>Specifies the time (in seconds) that an FA agent advertisement remains valid in the absence of further advertisements.</p> <p>The time can be configured to any integer value between 1 and 65535. The default is 9000.</p>

Required Information	Description
Number of allowable unanswered FA advertisements	<p>Specifies the number of unanswered agent advertisements that the FA service will allow during call setup before it will reject the session.</p> <p>The number can be any integer value between 1 and 65535. The default is 5.</p>
Maximum mobile-requested registration lifetime allowed	<p>Specifies the longest registration lifetime that the FA service will allow in any Registration Request message from the mobile node.</p> <p>The lifetime is expressed in seconds and can be configured between 1 and 65534. An infinite registration lifetime can be configured by disabling the timer. The default is 600 seconds.</p>
Registration reply timeout	<p>Specifies the amount of time that the FA service will wait for a Registration Reply from an HA.</p> <p>The time is measured in seconds and can be configured to any integer value between 1 and 65535. The default is 7.</p>
Number of simultaneous registrations	<p>Specifies the number of simultaneous Mobile IP sessions that will be supported for a single subscriber.</p> <p>The maximum number of sessions is 3. The default is 1.</p> <p>Important The system will only support multiple Mobile IP sessions per subscriber if the subscriber's mobile node has a static IP address.</p>
Mobile node re-registration requirements	<p>Specifies how the system should handle authentication for mobile node re-registrations.</p> <p>The FA service can be configured to always require authentication or not. If not, the initial registration and de-registration will still be handled normally.</p>

System-Level AAA Configuration

The following table lists the information that is required to configure the system-level AAA parameters.

Table 16: Required Information for System-Level AAA Configuration

Required Information	Description
Subscriber default domain name	<p>Specifies the name of a context that can provide AAA functions in the event that the domain-part of the username is missing or poorly formed.</p> <p>This parameter will be applied to all subscribers if their domain can not be determined from their username regardless of what domain they are trying to access.</p> <p>Important The default domain name can be the same as the source context.</p>
Subscriber Last-resort context	<p>Specifies the name of a context that can provide AAA functions in the event that the domain-part of the username was present but does not match the name of a configured destination context.</p> <p>This parameter will be applied to all subscribers if their specified domain does not match a configured destination context regardless of what domain they are trying to access.</p> <p>Important The last-resort context name can be the same as the source context.</p>

Required Information	Description
Subscriber username format	<p>Specifies the format of subscriber usernames as to whether or not the username or domain is specified first and the character that separates them. The possible separator characters are:</p> <ul style="list-style-type: none"> • @ • % • - • \ • # • / <p>Up to six username formats can be specified. The default is <i>username @</i>.</p> <p>Important The username string is searched from right to left for the separator character. Therefore, if there is one or more separator characters in the string, only the first one that is recognized is considered the actual separator. For example, if the default username format was used, then for the username string <i>user1@enterprise@isp1</i>, the system resolves to the username <i>user1@enterprise</i> with domain <i>isp1</i>.</p>

Optional Destination Context

The following table lists the information required to configure the optional destination context. As discussed previously, This context is required if: 1) reverse tunneling is disabled in the FA service, or 2) if access control lists (ACLs) are used.



Important

If ACLs are used, the destination context would only consist of the ACL configuration. Interface configuration would not be required.

Table 17: Required Information for Destination Context Configuration 0

Required Information	Description
Destination context name	<p>This is an identification string between 1 and 79 characters (alpha and/or numeric) by which the destination context will be recognized by the system.</p> <p>Important For this configuration, the destination context name should not match the domain name of a specific domain.</p>
PDN Interface Configuration	
PDN interface name	<p>This is an identification string between 1 and 79 characters (alpha and/or numeric) by which the interface will be recognized by the system.</p> <p>Multiple names are needed if multiple interfaces will be configured.</p> <p>PDN interfaces are configured in the destination context.</p>
IP address and subnet	<p>These will be assigned to the PDN interface.</p> <p>Multiple addresses and/or subnets are needed if multiple interfaces will be configured.</p>
Physical port number	<p>This specifies the physical port to which the interface will be bound. Ports are identified by the chassis slot number where the line card resides in, followed by the number of the physical connector on the line card. For example, port 17/1 identifies connector number 1 on the card in slot 17.</p> <p>A single physical port can facilitate multiple interfaces.</p>
Physical port description	<p>This is an identification string between 1 and 79 characters (alpha and/or numeric) by which the physical port will be recognized by the system.</p> <p>Multiple descriptions are needed if multiple ports will be used.</p> <p>Physical ports are configured within the destination context and are used to bind logical PDN interfaces.</p>
Gateway IP address(es)	Used when configuring static routes from the PDN interface(s) to a specific network.
IP Address Pool Configuration	

Required Information	Description
IP address pool name	<p>Each IP address pool is identified by a name. The pool name can be between 1 and 31 alpha and/or numeric characters and is case sensitive.</p> <p>IP address pools are configured in the destination context(s). Multiple address pools can be configured within a single context.</p>
IP pool addresses	<p>An initial address and a subnet, or a starting address and an ending address, are required for each configured pool. The pool will then consist of every possible address within the subnet, or all addresses from the starting address to the ending address.</p> <p>The pool can be configured as public, private, or static.</p> <p>If this IP pool is being used for Interchassis Session Recovery, it must be a static and srp-activated.</p>

How This Configuration Works

The following figure and the text that follows describe how this configuration with a single source and destination context would be used by the system to process a Mobile IP data call.

Figure 18: Call Processing When Using the system as a PDSN/FA

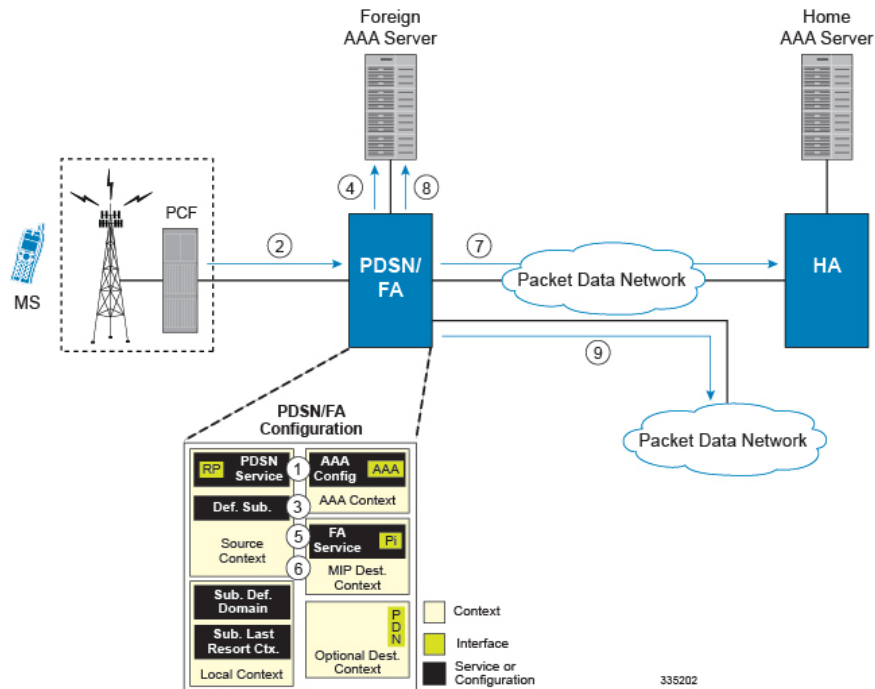

1. The system-level AAA settings were configured as follows:

- Subscriber default domain name = AAA context

- Subscriber username format = *username @*
- Subscriber last-resort context name = *AAA context*

2. A subscriber session from the PCF is received by the PDSN service over the R-P interface.
3. The PDSN service determines which context to use to provide foreign AAA functionality for the session. This process is described in the How the System Selects Contexts section located in the Understanding the System Operation and Configuration chapter of the *System Administration Guide*.

For this example, the result of this process is that PDSN service determined that foreign AAA functionality should be provided by the *AAA context*.

4. The system then communicates with the foreign AAA server specified in the AAA context's AAA configuration to authenticate the subscriber.
5. Upon successful authentication, the PDSN service determines the IP address of the subscriber's HA using either an attribute returned in the Access Accept message, or the address specified by the mobile.

The PDSN service uses the Mobile IP FA context name to determine what destination context is facilitating the FA service. In this example, it determines that it must use the *MIP Destination* context.

6. The PDSN service passes the HA IP address to the FA service.
7. The FA service then establishes a connection to the specified HA over the Pi interface.
8. Accounting messages for the session are sent to the Foreign AAA server over the AAA interface.
9. If reverse tunneling is disabled, then subscriber data traffic would have been routed over the PDN interface configured in the *Optional Destination* context.

Example 2: Mobile IP Support Using the System as an HA

The system supports both Simple and Mobile IP. For Mobile IP applications, the system can be configured to perform the function of a PDSN/FA and/or a HA. This example describes what is needed for and how the system performs the role of the HA. Example number 1 provides information on using the system to provide PDSN/FA functionality.

The system's HA configuration for Mobile IP applications requires that at least two contexts (one source and one destination) be configured as shown in the following figure .

Figure 19: Mobile IP Support Using the system as an HA

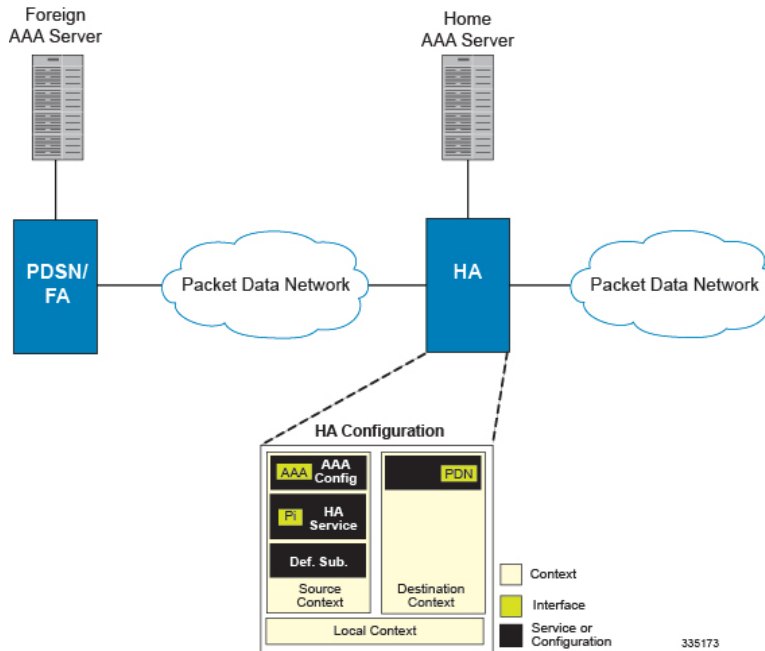

The source context will facilitate the HA service(s), the Pi interfaces from the FA, and the AAA interfaces. The source context will also be configured to provide Home AAA functionality for subscriber sessions. The destination context will facilitate the PDN interface(s).

Information Required

Prior to configuring the system as shown in this example, there is a minimum amount of information required. The following sections describe the information required to configure the source and destination contexts.

Source Context Configuration

The following table lists the information that is required to configure the source context.

Table 18: Required Information for Source Context Configuration

Required Information	Description
Source context name	This is an identification string between 1 and 79 characters (alpha and/or numeric) by which the source context will be recognized by the system. Important The name of the source context should be the same as the name of the context in which the FA-context is configured if a separate system is being used to provide PDSN/FA functionality.
Pi Interface Configuration	

Required Information	Description
Pi interface name	<p>This is an identification string between 1 and 79 characters (alpha and/or numeric) by which the interface will be recognized by the system.</p> <p>Multiple names are needed if multiple interfaces will be configured.</p> <p>Pi interfaces are configured in the source context.</p> <p>If this interface is being used for Interchassis Session Recovery, you must specify a loopback interface type after the interface_name.</p>
IP address and subnet	<p>These will be assigned to the Pi interface.</p> <p>Multiple addresses and/or subnets are needed if multiple interfaces will be configured.</p>
Physical port number	<p>This specifies the physical port to which the interface will be bound. Ports are identified by the chassis slot number where the line card resides in, followed by the number of the physical connector on the line card. For example, port 17/1 identifies connector number 1 on the card in slot 17.</p> <p>A single physical port can facilitate multiple interfaces.</p>
Physical port description	<p>This is an identification string between 1 and 79 characters (alpha and/or numeric) by which the physical port will be recognized by the system.</p> <p>Multiple descriptions are needed if using multiple ports.</p> <p>Physical ports are configured within the source context and are used to bind logical Pi interfaces.</p>
Gateway IP address	Used when configuring static routes from the R-P interface(s) to a specific network.
HA service Configuration	
HA service name	<p>This is an identification string between 1 and 63 characters (alpha and/or numeric) by which the HA service will be recognized by the system.</p> <p>Multiple names are needed if multiple HA services will be used.</p> <p>HA services are configured in the destination context.</p>
UDP port number for Mobile IP traffic	Specifies the port used by the HA service and the FA for communications. The UDP port number can be any integer value between 1 and 65535. The default value is 434.

Required Information	Description
Mobile node re-registration requirements	<p>Specifies how the system should handle authentication for mobile node re-registrations.</p> <p>The HA service can be configured as follows: Always require authentication</p> <p>Never require authentication (NOTE: the initial registration and de-registration will still be handled normally)</p> <p>Never look for mn-aaa extension</p> <p>Not require authentication but will authenticate if mn-aaa extension present</p>
FA-to-HA Security Parameter Index Information	<p>FA IP address:</p> <p>The HA service allows the creation of a security profile that can be associated with a particular FA. This specifies the IP address of the FA that the HA service will be communicating with.</p> <p>Multiple FA addresses are needed if the HA will be communicating with multiple FAs.</p>
	<p>Index:</p> <p>Specifies the shared SPI between the HA service and a particular FA. The SPI can be configured to any integer value between 256 and 4294967295.</p> <p>Multiple SPIs can be configured if the HA service is to communicate with multiple FAs.</p>
	<p>Secret:</p> <p>Specifies the shared SPI secret between the HA service and the FA. The secret can be between 1 and 127 characters (alpha and/or numeric).</p> <p>An SPI secret is required for each SPI configured.</p>
	<p>Hash-algorithm:</p> <p>Specifies the algorithm used to hash the SPI and SPI secret. The possible algorithms that can be configured are MD5 per RFC 1321 and keyed-MD5 per RFC 2002. The default algorithm is hmac-md5.</p> <p>A hash-algorithm is required for each SPI configured.</p>

Required Information	Description
Mobile Node Security Parameter Index Information	<p>Index:</p> <p>Specifies the shared SPI between the HA service and the mobile node(s). The SPI can be configured to any integer value between 256 and 4294967295.</p> <p>Multiple SPIs can be configured if the HA service is to communicate with multiple mobile nodes.</p>
	<p>Secret(s):</p> <p>Specifies the shared SPI secret between the HA service and the mobile node. The secret can be between 1 and 127 characters (alpha and/or numeric).</p> <p>An SPI secret is required for each SPI configured.</p>
	<p>Hash-algorithm:</p> <p>Specifies the algorithm used to hash the SPI and SPI secret. The possible algorithms that can be configured are MD5 per RFC 1321 and keyed-MD5 per RFC 2002. The default algorithm is hmac-md5.</p> <p>A hash-algorithm is required for each SPI configured.</p>
	<p>Replay-protection process:</p> <p>Specifies how protection against replay-attacks is implemented. The possible processes are nonce and timestamp. The default is timestamp with a tolerance of 60 seconds.</p> <p>A replay-protection process is required for each mobile node-to-HA SPI configured.</p>
Maximum registration lifetime	<p>Specifies the longest registration lifetime that the HA service will allow in any Registration Request message from the mobile node.</p> <p>The time is measured in seconds and can be configured to any integer value between 1 and 65534. An infinite registration lifetime can also be configured by disabling the timer. The default is 600.</p>
Maximum number of simultaneous bindings	<p>Specifies the maximum number of "care-of" addresses that can simultaneously be bound for the same user as identified by NAI and Home address.</p> <p>The number can be configured to any integer value between 1 and 5. The default is 3.</p>
AAA Interface Configuration	

Required Information	Description
AAA interface name	<p>This is an identification string between 1 and 79 characters (alpha and/or numeric) by which the interface will be recognized by the system.</p> <p>Multiple names are needed if multiple interfaces will be configured.</p> <p>AAA interfaces will be configured in the source context.</p>
IP address and subnet	<p>These will be assigned to the AAA interface.</p> <p>Multiple addresses and/or subnets are needed if multiple interfaces will be configured.</p>
Physical port number	<p>This specifies the physical port to which the interface will be bound. Ports are identified by the chassis slot number where the line card resides in, followed by the number of the physical connector on the line card. For example, port 17/1 identifies connector number 1 on the card in slot 17.</p> <p>A single physical port can facilitate multiple interfaces.</p>
Physical port description	<p>This is an identification string between 1 and 79 characters (alpha and/or numeric) by which the physical port will be recognized by the system.</p> <p>Multiple descriptions are needed if multiple ports will be used.</p> <p>Physical ports are configured within the source context and are used to bind logical AAA interfaces.</p>
Gateway IP address	<p>Used when configuring static routes from the AAA interface(s) to a specific network.</p>
Home RADIUS Server Configuration	
Home RADIUS Authentication server	<p>IP Address: Specifies the IP address of the home RADIUS authentication server the source context will communicate with to provide subscriber authentication functions.</p> <p>Multiple addresses are needed if multiple RADIUS servers will be configured.</p> <p>Home RADIUS authentication servers are configured within the source context. Multiple servers can be configured and each assigned a priority.</p>

Required Information	Description
	<p>Shared Secret:</p> <p>The shared secret is a string between 1 and 15 characters (alpha and/or numeric) that specifies the key that is exchanged between the RADIUS authentication server and the source context.</p> <p>A shared secret is needed for each configured RADIUS server.</p>
	<p>UDP Port Number:</p> <p>Specifies the port used by the source context and the home RADIUS authentication server for communications. The UDP port number can be any integer value between 1 and 65535. The default value is 1812.</p>
Home RADIUS Accounting server	<p>IP Address:</p> <p>Specifies the IP address of the home RADIUS accounting server that the source context will communicate with to provide subscriber accounting functions.</p> <p>Multiple addresses are needed if multiple RADIUS servers will be configured. Home RADIUS accounting servers are configured within the source context. Multiple servers can be configured and each assigned a priority.</p> <p>Shared Secret:</p> <p>The shared secret is a string between 1 and 15 characters (alpha and/or numeric) that specifies the key that is exchanged between the RADIUS accounting server and the source context.</p> <p>A shared secret is needed for each configured RADIUS server.</p> <p>UDP Port Number:</p> <p>Specifies the port used by the source context and the home RADIUS Accounting server for communications. The UDP port number can be any integer value between 1 and 65535. The default value is 1813.</p>
RADIUS attribute NAS Identifier	<p>Specifies the name by which the source context will be identified in the Access-Request message(s) it sends to the home RADIUS server. The name must be between 1 and 32 alpha and/or numeric characters and is case sensitive.</p>

Required Information	Description
RADIUS NAS IP address	Specifies the IP address of the source context's AAA interface. A secondary address can be optionally configured.
Default Subscriber Configuration	
"Default" subscriber's IP context name	Specifies the name of the egress context on the system that facilitates the PDN ports. Important For this configuration, the IP context name should be identical to the name of the destination context.

Destination Context Configuration

The following table lists the information required to configure the destination context.

Table 19: Required Information for Destination Context Configuration 1

Required Information	Description
Destination context name	This is an identification string between 1 and 79 characters (alpha and/or numeric) by which the destination context will be recognized by the system. Important For this configuration, the destination context name should not match the domain name of a specific domain.
PDN Interface Configuration	
PDN interface name	This is an identification string between 1 and 79 characters (alpha and/or numeric) by which the interface will be recognized by the system. Multiple names are needed if multiple interfaces will be configured. PDN interfaces are configured in the destination context.
IP address and subnet	These will be assigned to the PDN interface. Multiple addresses and/or subnets are needed if multiple interfaces will be configured.

Required Information	Description
Physical port number	<p>This specifies the physical port to which the interface will be bound. Ports are identified by the chassis slot number where the line card resides in, followed by the number of the physical connector on the line card. For example, port 17/1 identifies connector number 1 on the card in slot 17.</p> <p>A single physical port can facilitate multiple interfaces.</p>
Physical port description	<p>This is an identification string between 1 and 79 characters (alpha and/or numeric) by which the physical port will be recognized by the system.</p> <p>Multiple descriptions are needed if multiple ports will be used.</p> <p>Physical ports are configured within the destination context and are used to bind logical PDN interfaces.</p>
Gateway IP address(es)	Used when configuring static routes from the PDN interface(s) to a specific network.
IP Address Pool Configuration	
IP address pool name	<p>Each IP address pool is identified by a name. The pool name can be between 1 and 31 alpha and/or numeric characters and is case sensitive.</p> <p>IP address pools are configured in the destination context(s). Multiple address pools can be configured within a single context.</p>
IP pool addresses	<p>An initial address and a subnet, or a starting address and an ending address, are required for each configured pool. The pool will then consist of every possible address within the subnet, or all addresses from the starting address to the ending address.</p> <p>The pool can be configured as public, private, or static.</p> <p>If this IP pool is being used for Interchassis Session Recovery, it must be a static and srp-activated.</p>

How This Configuration Works

The following figure and the text that follows describe how this configuration with a single source and destination context would be used by the system to process a Mobile IP data call.

Figure 20: Call Processing When Using the system as a PDSN/FA

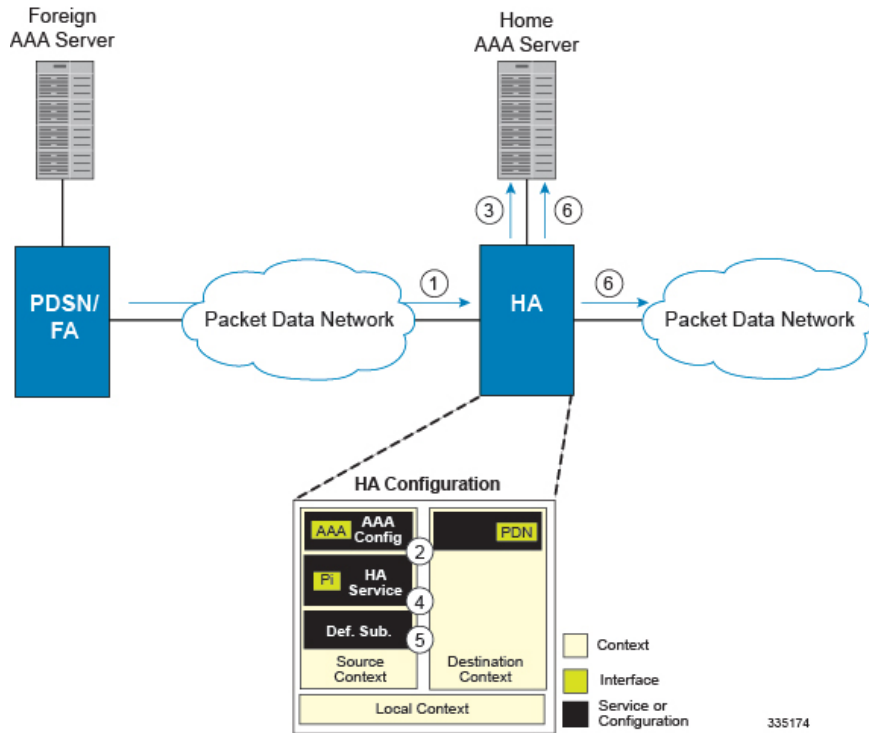

1. The system-level AAA settings were configured as follows:
 - Subscriber default domain name = *AAA context*
 - Subscriber username format = *username @*
 - Subscriber last-resort context name = *AAA context*
2. A subscriber session from the PCF is received by the PDSN service over the R-P interface.
3. The PDSN service determines which context to use to provide foreign AAA functionality for the session. This process is described in the How the System Selects Contexts section located in the Understanding the System Operation and Configuration chapter of the *System Administration Guide*.
For this example, the result of this process is that PDSN service determined that foreign AAA functionality should be provided by the *AAA context*.
4. The system then communicates with the foreign AAA server specified in the AAA context's AAA configuration to authenticate the subscriber.
5. Upon successful authentication, the PDSN service determines the IP address of the subscriber's HA using either an attribute returned in the Access Accept message, or the address specified by the mobile.
The PDSN service uses the Mobile IP FA context name to determine what destination context is facilitating the FA service. In this example, it determines that it must use the *MIP Destination* context.
6. The PDSN service passes the HA IP address to the FA service.
7. The FA service then establishes a connection to the specified HA over the Pi interface.

Example 3: HA Using a Single Source Context and Multiple Outsourced Destination Contexts

8. Accounting messages for the session are sent to the Foreign AAA server over the AAA interface.
9. If reverse tunneling is disabled, then subscriber data traffic would have been routed over the PDN interface configured in the *Optional Destination* context.

Example 3: HA Using a Single Source Context and Multiple Outsourced Destination Contexts

The system allows the wireless carrier to easily generate additional revenue by providing the ability to configure separate contexts that can then be leased or outsourced to various enterprises or ISPs, each having a specific domain.

In order to perform the role of an HA and support multiple outsourced domains, the system must be configured with at least one source context and multiple destination contexts as shown in the following figure. The AAA servers could be owned/maintained by either the carrier or the domain. If they are owned by the domain, the carrier will have to receive the AAA information via proxy.

Figure 21: The system as an HA Using a Single Source Context and Multiple Outsourced Destination Contexts

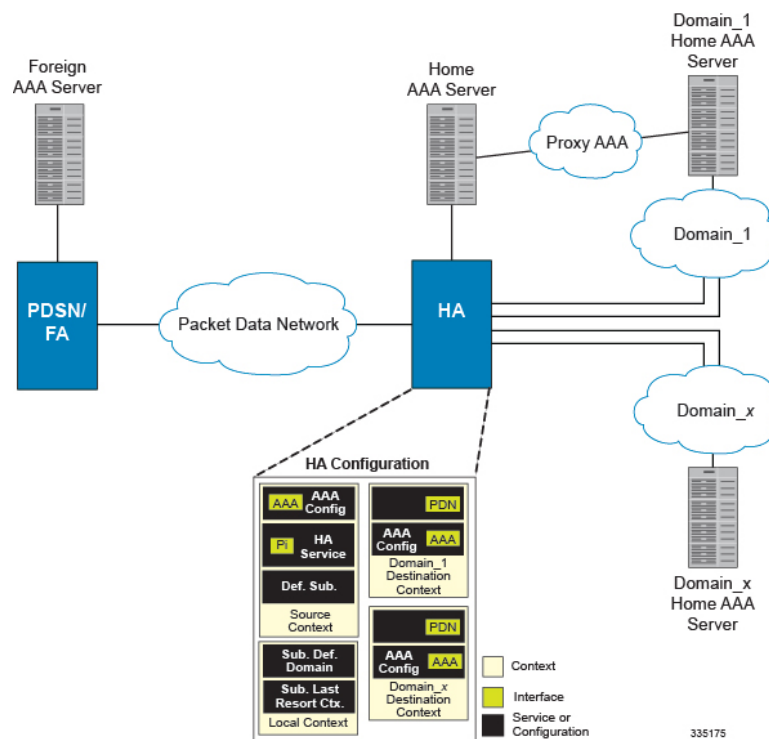

The source context will facilitate the HA service(s), and the Pi interface(s) to the FA(s). The source context will also be configured with AAA interface(s) and to provide Home AAA functionality for subscriber sessions. The destination contexts will each be configured to facilitate PDN interfaces. In addition, because each of the destination contexts can be outsourced to different domains, they will also be configured with AAA interface(s) and to provide AAA functionality for that domain.

In addition to the source and destination contexts, there are additional system-level AAA parameters that must be configured.

Information Required

Prior to configuring the system as shown in this example, there is a minimum amount of information required. The following sections describe the information required to configure the source and destination contexts.

Source Context Configuration

The following table lists the information that is required to configure the source context.

Table 20: Required Information for Source Context Configuration 4

Required Information	Description
Source context name	This is an identification string between 1 and 79 characters (alpha and/or numeric) by which the source context will be recognized by the system.
Pi Interface Configuration	
Piinterface name	This is an identification string between 1 and 79 characters (alpha and/or numeric) by which the interface will be recognized by the system. Multiple names are needed if multiple interfaces will be configured. Pi interfaces are configured in the source context.
IP address and subnet	These will be assigned to the Pi interface. Multiple addresses and/or subnets are needed if multiple interfaces will be configured.
Physical port number	This specifies the physical port to which the interface will be bound. Ports are identified by the chassis slot number where the line card resides in, followed by the number of the physical connector on the line card. For example, port 17/1 identifies connector number 1 on the card in slot 17. A single physical port can facilitate multiple interfaces.
Physical port description	This is an identification string between 1 and 79 characters (alpha and/or numeric) by which the physical port will be recognized by the system. Multiple descriptions are needed if using multiple ports. Physical ports are configured within the source context and are used to bind logical Pi interfaces.
Gateway IP address	Used when configuring static routes from the Pi interface(s) to a specific network.

Required Information	Description
HA service Configuration	
HA service name	<p>This is an identification string between 1 and 63 characters (alpha and/or numeric) by which the PDSN service will be recognized by the system.</p> <p>Multiple names are needed if using multiple HA services.</p> <p>HA services are configured in the source context.</p>
UDP port number for Mobile IP traffic	<p>Specifies the port used by the HA service and the FA for communications. The UDP port number can be any integer value between 1 and 65535. The default value is 434.</p>
Mobile node re-registration requirements	<p>Specifies how the system should handle authentication for mobile node re-registrations.</p> <p>The HA service can be configured as follows:</p> <p>Always require authentication</p> <p>Never require authentication (NOTE: the initial registration and de-registration will still be handled normally)</p> <p>Never look for mn-aaa extension</p> <p>Not require authentication but will authenticate if mn-aaa extension present</p>

Required Information	Description
FA-to-HA Security Parameter Index Information	<p>FA IP address:</p> <p>The HA service allows the creation of a security profile that can be associated with a particular FA.</p> <p>This specifies the IP address of the FA that the HA service will be communicating with.</p> <p>Multiple FA addresses are needed if the HA will be communicating with multiple FAs.</p> <hr/> <p>Index:</p> <p>Specifies the shared SPI between the HA service and a particular FA. The SPI can be configured to any integer value between 256 and 4294967295.</p> <p>Multiple SPIs can be configured if the HA service is to communicate with multiple FAs.</p> <hr/> <p>Secret:</p> <p>Specifies the shared SPI secret between the HA service and the FA. The secret can be between 1 and 127 characters (alpha and/or numeric).</p> <p>An SPI secret is required for each SPI configured.</p> <hr/> <p>Hash-algorithm:</p> <p>Specifies the algorithm used to hash the SPI and SPI secret. The possible algorithms that can be configured are MD5 per RFC 1321 and keyed-MD5 per RFC 2002. The default algorithm is hmac-md5.</p> <p>A hash-algorithm is required for each SPI configured.</p>

Required Information	Description
Mobile Node Security Parameter Index Information	<p>Index:</p> <p>Specifies the shared SPI between the HA service and the mobile node(s). The SPI can be configured to any integer value between 256 and 4294967295.</p> <p>Multiple SPIs can be configured if the HA service is to communicate with multiple mobile nodes.</p> <p>Secret(s):</p> <p>Specifies the shared SPI secret between the HA service and the mobile node. The secret can be between 1 and 127 characters (alpha and/or numeric).</p> <p>An SPI secret is required for each SPI configured.</p> <p>Hash-algorithm:</p> <p>Specifies the algorithm used to hash the SPI and SPI secret. The possible algorithms that can be configured are MD5 per RFC 1321 and keyed-MD5 per RFC 2002. The default algorithm is hmac-md5.</p> <p>A hash-algorithm is required for each SPI configured.</p> <p>Replay-protection process:</p> <p>Specifies how protection against replay-attacks is implemented. The possible processes are nonce and timestamp. The default is timestamp with a tolerance of 60 seconds.</p> <p>A replay-protection process is required for each mobile node-to-HA SPI configured.</p>
Maximum registration lifetime	<p>Specifies the longest registration lifetime that the HA service will allow in any Registration Request message from the mobile node.</p> <p>The time is measured in seconds and can be configured to any integer value between 1 and 65535. An infinite registration lifetime can also be configured by disabling the timer. The default is 600.</p>
Maximum number of simultaneous bindings	<p>Specifies the maximum number of "care-of" addresses that can simultaneously be bound for the same user as identified by NAI and Home address.</p> <p>The number can be configured to any integer value between 1 and 5. The default is 3.</p>
AAA Interface Configuration	

Required Information	Description
AAA interface name	<p>This is an identification string between 1 and 79 characters (alpha and/or numeric) by which the interface will be recognized by the system.</p> <p>Multiple names are needed if multiple interfaces will be configured.</p> <p>AAA interfaces will be configured in the source context.</p>
IP address and subnet	<p>These will be assigned to the AAA interface.</p> <p>Multiple addresses and/or subnets are needed if multiple interfaces will be configured.</p>
Physical port number	<p>This specifies the physical port to which the interface will be bound. Ports are identified by the chassis slot number where the line card resides in, followed by the number of the physical connector on the line card. For example, port 17/1 identifies connector number 1 on the card in slot 17.</p> <p>A single physical port can facilitate multiple interfaces.</p>
Physical port description	<p>This is an identification string between 1 and 79 characters (alpha and/or numeric) by which the physical port will be recognized by the system.</p> <p>Multiple descriptions are needed if multiple ports will be used.</p> <p>Physical ports are configured within the source context and are used to bind logical AAA interfaces.</p>
Gateway IP address	<p>Used when configuring static routes from the AAA interface(s) to a specific network.</p>
Home RADIUS Server Configuration	

Required Information	Description
Home RADIUS Authentication server	<p>IP Address:</p> <p>Specifies the IP address of the home RADIUS authentication server the source context will communicate with to provide subscriber authentication functions.</p> <p>Multiple addresses are needed if multiple RADIUS servers will be configured.</p> <p>Home RADIUS authentication servers are configured within the source context. Multiple servers can be configured and each assigned a priority.</p>
	<p>Shared Secret:</p> <p>The shared secret is a string between 1 and 15 characters (alpha and/or numeric) that specifies the key that is exchanged between the RADIUS authentication server and the source context.</p> <p>A shared secret is needed for each configured RADIUS server.</p>
	<p>UDP Port Number:</p> <p>Specifies the port used by the source context and the home RADIUS authentication server for communications. The UDP port number can be any integer value between 1 and 65535. The default value is 1812.</p>

Required Information	Description
Home RADIUS Accounting server	<p data-bbox="963 285 1089 312">IP Address:</p> <p data-bbox="963 331 1516 453">Specifies the IP address of the home RADIUS accounting server that the source context will communicate with to provide subscriber accounting functions.</p> <p data-bbox="963 474 1516 535">Multiple addresses are needed if multiple RADIUS servers will be configured.</p> <p data-bbox="963 556 1516 646">Home RADIUS accounting servers are configured within the source context. Multiple servers can be configured and each assigned a priority.</p> <p data-bbox="963 674 1117 701">Shared Secret:</p> <p data-bbox="963 722 1516 844">The shared secret is a string between 1 and 15 characters (alpha and/or numeric) that specifies the key that is exchanged between the RADIUS accounting server and the source context.</p> <p data-bbox="963 865 1451 926">A shared secret is needed for each configured RADIUS server.</p> <p data-bbox="963 953 1166 980">UDP Port Number:</p> <p data-bbox="963 1001 1516 1157">Specifies the port used by the source context and the home RADIUS Accounting server for communications. The UDP port number can be any integer value between 1 and 65535. The default value is 1813.</p>
RADIUS attribute NAS Identifier	<p data-bbox="963 1188 1516 1339">Specifies the name by which the source context will be identified in the Access-Request message(s) it sends to the home RADIUS server. The name must be between 1 and 32 alpha and/or numeric characters and is case sensitive.</p>
RADIUS NAS IP address	<p data-bbox="963 1371 1516 1461">Specifies the IP address of the source context's AAA interface. A secondary address can be optionally configured.</p>
Default Subscriber Configuration	
"Default" subscriber's IP context name	<p data-bbox="963 1549 1516 1610">Specifies the name of the egress context on the system that facilitates the PDN ports.</p> <p data-bbox="963 1631 1516 1713">Important For this configuration, the IP context name should be identical to the name of the destination context.</p>

Destination Context Configuration

The following table lists the information required to configure the destination context.

Table 21: Required Information for Destination Context Configuration 6

Required Information	Description
Destination context name	<p>This is an identification string between 1 and 79 characters (alpha and/or numeric) by which the destination context will be recognized by the system.</p> <p>Important For this configuration, the destination context name should not match the domain name of a specific domain.</p>
PDN Interface Configuration	
PDN interface name	<p>This is an identification string between 1 and 79 characters (alpha and/or numeric) by which the interface will be recognized by the system.</p> <p>Multiple names are needed if multiple interfaces will be configured.</p> <p>PDN interfaces are configured in the destination context.</p>
IP address and subnet	<p>These will be assigned to the PDN interface.</p> <p>Multiple addresses and/or subnets are needed if multiple interfaces will be configured.</p>
Physical port number	<p>This specifies the physical port to which the interface will be bound. Ports are identified by the chassis slot number where the line card resides in, followed by the number of the physical connector on the line card. For example, port 17/1 identifies connector number 1 on the card in slot 17.</p> <p>A single physical port can facilitate multiple interfaces.</p>
Physical port description	<p>This is an identification string between 1 and 79 characters (alpha and/or numeric) by which the physical port will be recognized by the system.</p> <p>Multiple descriptions are needed if multiple ports will be used.</p> <p>Physical ports are configured within the destination context and are used to bind logical PDN interfaces.</p>
Gateway IP address(es)	<p>Used when configuring static routes from the PDN interface(s) to a specific network.</p>
IP Address Pool Configuration	

Required Information	Description
IP address pool name	<p>Each IP address pool is identified by a name. The pool name can be between 1 and 31 alpha and/or numeric characters and is case sensitive.</p> <p>IP address pools are configured in the destination context(s). Multiple address pools can be configured within a single context.</p>
IP pool addresses	<p>An initial address and a subnet, or a starting address and an ending address, are required for each configured pool. The pool will then consist of every possible address within the subnet, or all addresses from the starting address to the ending address.</p> <p>The pool can be configured as public, private, or static.</p> <p>If this IP pool is being used for Interchassis Session Recovery, it must be a static and srp-activated.</p>
AAA Interface Configuration	
AAA interface name	<p>This is an identification string between 1 and 79 characters (alpha and/or numeric) by which the interface will be recognized by the system.</p> <p>Multiple names are needed if multiple interfaces will be configured.</p> <p>AAA interfaces will be configured in the source context.</p>
IP address and subnet	<p>These will be assigned to the AAA interface.</p> <p>Multiple addresses and/or subnets are needed if multiple interfaces will be configured.</p>
Physical port number	<p>This specifies the physical port to which the interface will be bound. Ports are identified by the chassis slot number where the line card resides in, followed by the number of the physical connector on the line card. For example, port 17/1 identifies connector number 1 on the card in slot 17.</p> <p>A single physical port can facilitate multiple interfaces.</p>
Physical port description	<p>This is an identification string between 1 and 79 characters (alpha and/or numeric) by which the physical port will be recognized by the system.</p> <p>Multiple descriptions are needed if multiple ports will be used.</p> <p>Physical ports are configured within the source context and are used to bind logical AAA interfaces.</p>

Required Information	Description
Gateway IP address	Used when configuring static routes from the AAA interface(s) to a specific network.
Home RADIUS Server Configuration	
Home RADIUS Authentication server	<p>IP Address:</p> <p>Specifies the IP address of the home RADIUS authentication server the source context will communicate with to provide subscriber authentication functions.</p> <p>Multiple addresses are needed if multiple RADIUS servers will be configured.</p> <p>Home RADIUS authentication servers are configured within the source context. Multiple servers can be configured and each assigned a priority.</p>
	<p>Shared Secret:</p> <p>The shared secret is a string between 1 and 15 characters (alpha and/or numeric) that specifies the key that is exchanged between the RADIUS authentication server and the source context.</p> <p>A shared secret is needed for each configured RADIUS server.</p>
	<p>UDP Port Number:</p> <p>Specifies the port used by the source context and the home RADIUS authentication server for communications. The UDP port number can be any integer value between 1 and 65535. The default value is 1812.</p>

Required Information	Description
Home RADIUS Accounting server	<p data-bbox="964 283 1089 310">IP Address:</p> <p data-bbox="964 331 1516 453">Specifies the IP address of the home RADIUS accounting server that the source context will communicate with to provide subscriber accounting functions.</p> <p data-bbox="964 474 1516 533">Multiple addresses are needed if multiple RADIUS servers will be configured.</p> <p data-bbox="964 554 1516 646">Home RADIUS accounting servers are configured within the source context. Multiple servers can be configured and each assigned a priority.</p> <hr/> <p data-bbox="964 674 1117 701">Shared Secret:</p> <p data-bbox="964 722 1516 844">The shared secret is a string between 1 and 15 characters (alpha and/or numeric) that specifies the key that is exchanged between the RADIUS accounting server and the source context.</p> <p data-bbox="964 865 1451 924">A shared secret is needed for each configured RADIUS server.</p> <hr/> <p data-bbox="964 951 1166 978">UDP Port Number:</p> <p data-bbox="964 999 1516 1155">Specifies the port used by the source context and the home RADIUS Accounting server for communications. The UDP port number can be any integer value between 1 and 65535. The default value is 1813.</p>
RADIUS attribute NAS Identifier	<p data-bbox="964 1186 1516 1341">Specifies the name by which the source context will be identified in the Access-Request message(s) it sends to the home RADIUS server. The name must be between 1 and 32 alpha and/or numeric characters and is case sensitive.</p>
RADIUS NAS IP address	<p data-bbox="964 1369 1516 1461">Specifies the IP address of the source context's AAA interface. A secondary address can be optionally configured.</p>

System-Level AAA Configuration

The following table lists the information that is required to configure the system-level AAA parameters.

Table 22: Required Information for System-Level AAA Configuration

Required Information	Description
Subscriber default domain name	<p>Specifies the name of a context that can provide AAA functions in the event that the domain-part of the username is missing or poorly formed.</p> <p>This parameter will be applied to all subscribers if their domain can not be determined from their username regardless of what domain they are trying to access.</p> <p>Important The default domain name can be the same as the source context.</p>
Subscriber Last-resort context	<p>Specifies the name of a context that can provide AAA functions in the event that the domain-part of the username was present but does not match the name of a configured destination context.</p> <p>This parameter will be applied to all subscribers if their specified domain does not match a configured destination context regardless of what domain they are trying to access.</p> <p>Important The last-resort context name can be the same as the source context.</p>

Required Information	Description
Subscriber username format	<p>Specifies the format of subscriber usernames as to whether or not the username or domain is specified first and the character that separates them. The possible separator characters are:</p> <ul style="list-style-type: none"> • @ • % • - • \ • # • / <p>Up to six username formats can be specified. The default is <i>username @</i>.</p> <p>Important The username string is searched from right to left for the separator character. Therefore, if there is one or more separator characters in the string, only the first one that is recognized is considered the actual separator. For example, if the default username format was used, then for the username string <i>user1@enterprise@isp1</i>, the system resolves to the username <i>user1@enterprise</i> with domain <i>isp1</i>.</p>

How This Configuration Works

The following figure and the text that follows describe how this configuration with a single source and destination context would be used by the system to process a Mobile IP data call.

Figure 22: Call Processing When Using the system as a PDSN/FA

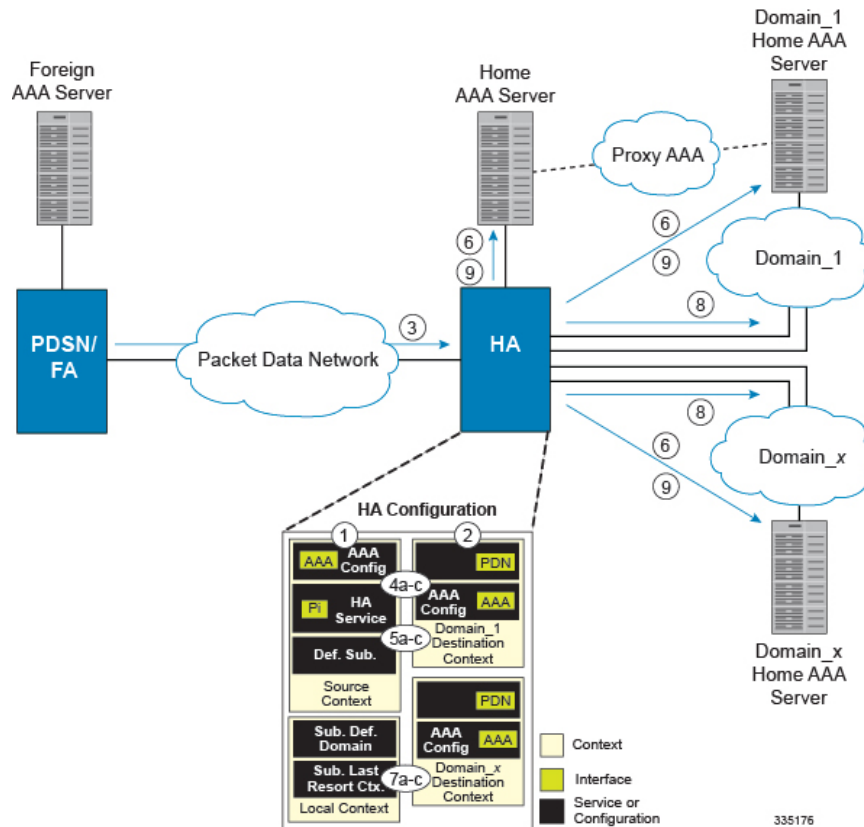

- The system-level AAA settings were configured as follows:
 - Subscriber default domain name = *AAA context*
 - Subscriber username format = *username @*
 - Subscriber last-resort context name = *AAA context*
- A subscriber session from the PCF is received by the PDSN service over the R-P interface.
- The PDSN service determines which context to use to provide foreign AAA functionality for the session. This process is described in the How the System Selects Contexts section located in the Understanding the System Operation and Configuration chapter of the *System Administration Guide*.
 For this example, the result of this process is that PDSN service determined that foreign AAA functionality should be provided by the *AAA context*.
- The system then communicates with the foreign AAA server specified in the AAA context's AAA configuration to authenticate the subscriber.
- Upon successful authentication, the PDSN service determines the IP address of the subscriber's HA using either an attribute returned in the Access Accept message, or the address specified by the mobile.
 The PDSN service uses the Mobile IP FA context name to determine what destination context is facilitating the FA service. In this example, it determines that it must use the *MIP Destination context*.
- The PDSN service passes the HA IP address to the FA service.

7. The FA service then establishes a connection to the specified HA over the Pi interface.
8. Accounting messages for the session are sent to the Foreign AAA server over the AAA interface.



CHAPTER 5

Simple IP and Mobile IP in a Single System Configuration Example

This chapter provides information for several configuration examples that can be implemented on the system to support Simple IP and Mobile IP data services in a single system.



Important

This chapter does not discuss the configuration of the localout-of-band management context. Information about the localout-of-band management context can be found in Chapter 1 of *Command Line Reference*. Additionally, when configuring Mobile IP take into account the MIP timing considerations discussed in the section MIP Timer Considerations.

The following topics are covered:

- [Using the System as Both a PDSN/FA and an HA, on page 133](#)

Using the System as Both a PDSN/FA and an HA

The system supports both Simple and Mobile IP. For Mobile IP applications, the system can be configured to perform the function of a Packet Data Service Node/Foreign Agent (PDSN/FA) and/or a Home Agent (HA). This example describes what is needed and how a single system simultaneously supports both of these functions.

In order to support PDSN, FA, and HA functionality, the system must be configured with at least one source context and at least two destination contexts as shown in the following figure.

The source context will facilitate the PDSN service(s), and the R-P interfaces. The AAA context will be configured to provide foreign/home AAA functionality for subscriber sessions and facilitate the AAA interfaces.

The Mobile IP destination context will be configured to facilitate the FA service, the HA service and the PDN interfaces for Mobile IP data services. The Simple IP destination context will facilitate the PDN interfaces for Simple IP data Services.

In addition to the source and destination contexts, there are additional system-level AAA parameters that must be configured.

Figure 23: Simple and Mobile IP Support Within a Single System

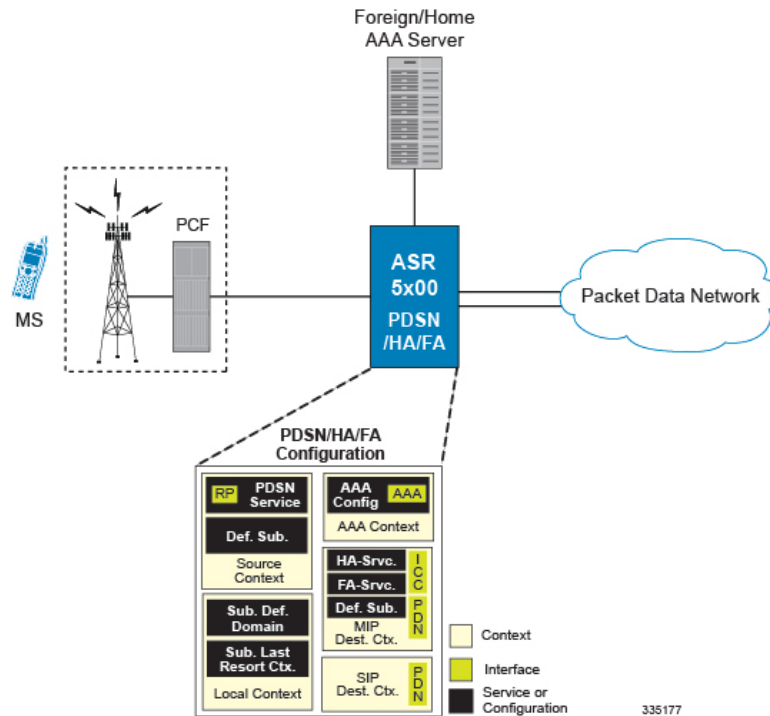

Information Required

Prior to configuring the system as shown in this example, there is a minimum amount of information required. The following sections describe the required information to configure the source and destination contexts.

Source Context Configuration

The following table lists the information that is required to configure the source context.

Table 23: Required Information for Source Context Configuration

Required Information	Description
Source context name	This is an identification string between 1 and 79 characters (alpha and/or numeric) by which the source context will be recognized by the system.
R-P Interface Configuration	
R-P interface name	This is an identification string between 1 and 79 characters (alpha and/or numeric) by which the interface will be recognized by the system. Multiple names are needed if multiple interfaces will be configured. R-P interfaces are configured in the source context.

Required Information	Description
IP address and subnet	<p>These will be assigned to the R-P interface.</p> <p>Multiple addresses and/or subnets are needed if multiple interfaces will be configured.</p>
Physical port number	<p>This specifies the physical port to which the interface will be bound. Ports are identified by the chassis slot number where the line card resides in, followed by the number of the physical connector on the line card. For example, port 17/1 identifies connector number 1 on the card in slot 17.</p> <p>A single physical port can facilitate multiple interfaces.</p>
Physical port description	<p>This is an identification string between 1 and 79 characters (alpha and/or numeric) by which the physical port will be recognized by the system.</p> <p>Multiple descriptions are needed if multiple ports will be used.</p> <p>Physical ports are configured within the source context and are used to bind logical R-P interfaces.</p>
Gateway IP address	Used when configuring static routes from the R-P interface(s) to a specific network.
PDSN service Configuration	
PDSN service name	<p>This is an identification string between 1 and 63 characters (alpha and/or numeric) by which the PDSN service will be recognized by the system.</p> <p>Multiple names are needed if multiple PDSN services will be used.</p> <p>PDSN services are configured in the source context.</p>
UDP port number for R-P traffic	Specifies the port used by the PDSN service and the PCF for communications. The UDP port number and can be any integer value between 1 and 65535. The default value is 699.
Authentication protocols used	Specifies how the system handles authentication: using a protocol (such as CHAP, PAP, or MSCHAP), or not requiring any authentication.
Domain alias for NAI-construction	Specifies a context name for the system to use to provide accounting functionality for a subscriber session. This parameter is needed only if the system is configured to support no authentication.

Required Information	Description
Security Parameter Index Information	<p>PCF IP address:</p> <p>Specifies the IP address of the PCF that the PDSN service will be communicating with. The PDSN service allows the creation of a security profile that can be associated with a particular PCF.</p> <p>Multiple IP addresses are needed if the PDSN service will be communicating with multiple PCFs.</p> <p>Index:</p> <p>Specifies the shared SPI between the PDSN service and a particular PCF. The SPI can be configured to any integer value between 256 and 4294967295.</p> <p>Multiple SPIs can be configured if the PDSN service is to communicate with multiple PCFs.</p> <p>Secret:</p> <p>Specifies the shared SPI secret between the PDSN service and the PCF. The secret can be between 1 and 127 characters (alpha and/or numeric).</p> <p>An SPI secret is required for each SPI configured.</p> <p>Hash-algorithm:</p> <p>Specifies the algorithm used to hash the SPI and SPI secret. The possible algorithms that can be configured are MD5 per RFC 1321 and keyed-MD5 per RFC 2002. The default is MD5.</p> <p>A hash-algorithm is required for each SPI configured.</p> <p>Replay-protection process:</p> <p>Specifies how protection against replay-attacks is implemented. The possible processes are nonce and timestamp. The default is timestamp with a tolerance of 60 seconds.</p> <p>A replay-protection process is required for each SPI configured.</p>
Subscriber session lifetime	<p>Specifies the time in seconds that an A10 connection can exist before its registration is considered expired.</p> <p>The time is expressed in seconds and can be configured to any integer value between 1 and 65534, or the timer can be disabled to set an infinite lifetime. The default value is 1800 seconds.</p>
Mobile IP FA context name	<p>Specifies the name of the context in which the FA service is configured.</p>

Required Information	Description
Default Subscriber Configuration	
"Default" subscriber's IP context name	<p>Specifies the name of the egress context on the system that facilitates the PDN ports.</p> <p>Important For this configuration, the IP context name should be identical to the name of the destination context.</p>

AAA Context Configuration

The following table lists the information that is required to configure the AAA context.

Table 24: Required Information for AAA Context Configuration

Required Information	Description
AAA context name	This is an identification string between 1 and 79 characters (alpha and/or numeric) by which the AAA context will be recognized by the system.
AAA Interface Configuration	
AAA interface name	<p>This is an identification string between 1 and 79 characters (alpha and/or numeric) by which the interface will be recognized by the system.</p> <p>Multiple names are needed if multiple interfaces will be configured.</p> <p>AAA interfaces will be configured in the source context.</p>
IP address and subnet	<p>These will be assigned to the AAA interface.</p> <p>Multiple addresses and/or subnets are needed if multiple interfaces will be configured.</p>
Physical port number	<p>This specifies the physical port to which the interface will be bound. Ports are identified by the chassis slot number where the line card resides in, followed by the number of the physical connector on the line card. For example, port 17/1 identifies connector number 1 on the card in slot 17.</p> <p>A single physical port can facilitate multiple interfaces.</p>

Required Information	Description
Physical port description	<p>This is an identification string between 1 and 79 characters (alpha and/or numeric) by which the physical port will be recognized by the system.</p> <p>Multiple descriptions are needed if multiple ports will be used.</p> <p>Physical ports are configured within the source context and are used to bind logical AAA interfaces.</p>
Gateway IP address	Used when configuring static routes from the AAA interface(s) to a specific network.
Foreign/Home RADIUS Server Configuration	
Foreign/Home RADIUS Authentication server	<p>IP Address:</p> <p>Specifies the IP address of the foreign/home RADIUS authentication server the source context will communicate with to provide subscriber authentication functions.</p> <p>Multiple addresses are needed if multiple RADIUS servers will be configured.</p> <p>Foreign/home RADIUS authentication servers are configured within the source context. Multiple servers can be configured and each assigned a priority.</p>
	<p>Shared Secret:</p> <p>The shared secret is a string between 1 and 15 characters (alpha and/or numeric) that specifies the key that is exchanged between the RADIUS authentication server and the source context.</p> <p>A shared secret is needed for each configured RADIUS server.</p>
	<p>UDP Port Number:</p> <p>Specifies the port used by the source context and the foreign/home RADIUS authentication server for communications. The UDP port number can be any integer value between 1 and 65535. The default value is 1812.</p>

Required Information	Description
Foreign/Home RADIUS Accounting server	<p data-bbox="963 285 1089 312">IP Address:</p> <p data-bbox="963 331 1523 453">Specifies the IP address of the foreign/home RADIUS accounting server that the source context will communicate with to provide subscriber accounting functions.</p> <p data-bbox="963 474 1523 535">Multiple addresses are needed if multiple RADIUS servers will be configured.</p> <p data-bbox="963 556 1523 646">Foreign/home RADIUS accounting servers are configured within the source context. Multiple servers can be configured and each assigned a priority.</p> <p data-bbox="963 674 1117 701">Shared Secret:</p> <p data-bbox="963 720 1523 842">The shared secret is a string between 1 and 15 characters (alpha and/or numeric) that specifies the key that is exchanged between the RADIUS accounting server and the source context.</p> <p data-bbox="963 863 1450 924">A shared secret is needed for each configured RADIUS server.</p> <p data-bbox="963 951 1166 978">UDP Port Number:</p> <p data-bbox="963 997 1523 1157">Specifies the port used by the source context and the foreign/home RADIUS Accounting server for communications. The UDP port number can be any integer value between 1 and 65535. The default value is 1813.</p>
RADIUS attribute NAS Identifier	<p data-bbox="963 1188 1523 1339">Specifies the name by which the source context will be identified in the Access-Request message(s) it sends to the foreign/home RADIUS server. The name must be between 1 and 32 alpha and/or numeric characters and is case sensitive.</p>
RADIUS NAS IP address	<p data-bbox="963 1371 1523 1461">Specifies the IP address of the source context's AAA interface. A secondary IP address interface can optionally be configured.</p>

Mobile IP Destination Context Configuration

The following table lists the information that is required to configure the destination context.

Table 25: Required Information for Destination Context Configuration

Required Information	Description
Mobile IP Destination context name	<p>This is an identification string between 1 and 79 characters (alpha and/or numeric) by which the Mobile IP destination context will be recognized by the system.</p> <p>Important For this configuration, the destination context name should not match the domain name of a specific domain. It should, however, match the name of the context in which the HA service is configured if a separate system is used to provide HA functionality.</p>
ICC Interface Configuration	
ICC interface name	<p>The intra-context communication (ICC) interface is configured to allow FA and HA services configured within the same context to communicate with each other.</p> <p>The ICC interface name is an identification string between 1 and 79 characters (alpha and/or numeric) by which the interface will be recognized by the system.</p> <p>Multiple names are needed if multiple interfaces will be configured.</p> <p>ICC interface(s) are configured in the same destination context as the FA and HA services.</p>
IP address and subnet	<p>These will be assigned to the ICC interface(s).</p> <p>Multiple addresses (at least one per service) on the same subnet will be needed to assign to the same ICC interface.</p>
Physical port number	<p>This specifies the physical port to which the interface will be bound. Ports are identified by the chassis slot number where the line card resides in, followed by the number of the physical connector on the line card. For example, port 17/1 identifies connector number 1 on the card in slot 17.</p> <p>A single physical port can facilitate multiple interfaces.</p>

Required Information	Description
Physical port description	<p>This is an identification string between 1 and 79 characters (alpha and/or numeric) by which the physical port will be recognized by the system.</p> <p>Multiple descriptions are needed if multiple ports will be used.</p> <p>Physical ports are configured within the destination context and are used to bind logical ICC interfaces.</p>
PDN Interface Configuration	
PDN interface name	<p>This is an identification string between 1 and 79 characters (alpha and/or numeric) by which the interface will be recognized by the system.</p> <p>Multiple names are needed if multiple interfaces will be configured.</p> <p>PDN interfaces are configured in the destination context.</p>
IP address and subnet	<p>These will be assigned to the PDN interface.</p> <p>Multiple addresses and/or subnets are needed if multiple interfaces will be configured.</p>
Physical port number	<p>This specifies the physical port to which the interface will be bound. Ports are identified by the chassis slot number where the line card resides in, followed by the number of the physical connector on the line card. For example, port 17/1 identifies connector number 1 on the card in slot 17.</p> <p>A single physical port can facilitate multiple interfaces.</p>
Physical port description(s)	<p>This is an identification string between 1 and 79 characters (alpha and/or numeric) by which the physical port will be recognized by the system.</p> <p>Multiple descriptions will be needed if multiple ports will be used.</p> <p>Physical ports are configured within the destination context and are used to bind logical PDN interfaces.</p>
Gateway IP address(es)	<p>Used when configuring static routes from the PDN interface(s) to a specific network.</p>
IP Address Pool Configuration (optional)	

Required Information	Description
IP address pool name(s)	If IP address pools will be configured in the destination context(s), names or identifiers will be needed for them. The pool name can be between 1 and 31 alpha and/or numeric characters and is case sensitive.
IP pool addresses	An initial address and a subnet, or a starting address and an ending address, are required for each configured pool. The pool will then consist of every possible address within the subnet , or all addresses from the starting address to the ending address. The pool can be configured as public, private, or static.
FA Service Configuration	
FA service name	This is an identification string between 1 and 63 characters (alpha and/or numeric) by which the FA service will be recognized by the system. Multiple names are needed if multiple FA services will be used. FA services are configured in the destination context.
UDP port number for Mobile IP traffic	Specifies the port used by the FA service and the HA for communications. The UDP port number can be any integer value between 1 and 65535. The default value is 434.

Required Information	Description
Security Parameter Index (indices) Information	<p>HA IP address:</p> <p>Specifies the IP address of the HAs with which the FA service communicates. The FA service allows the creation of a security profile that can be associated with a particular HA.</p>
	<p>Index:</p> <p>Specifies the shared SPI between the FA service and a particular HA. The SPI can be configured to any integer value between 256 and 4294967295.</p> <p>Multiple SPIs can be configured if the FA service is to communicate with multiple HAs.</p>
	<p>Secrets:</p> <p>Specifies the shared SPI secret between the FA service and the HA. The secret can be between 1 and 127 characters (alpha and/or numeric).</p> <p>An SPI secret is required for each SPI configured.</p>
	<p>Hash-algorithm:</p> <p>Specifies the algorithm used to hash the SPI and SPI secret. The possible algorithms that can be configured are MD5 per RFC 1321 and keyed-MD5 per RFC 2002. The default is hmac-md5.</p> <p>A hash-algorithm is required for each SPI configured.</p>
FA agent advertisement lifetime	<p>Specifies the time (in seconds) that an FA agent advertisement remains valid in the absence of further advertisements.</p> <p>The time can be configured to any integer value between 1 and 65535. The default is 9000.</p>
Number of allowable unanswered FA advertisements	<p>Specifies the number of unanswered agent advertisements that the FA service will allow during call setup before it will reject the session.</p> <p>The number can be any integer value between 1 and 65535. The default is 5.</p>
Maximum mobile-requested registration lifetime allowed	<p>Specifies the longest registration lifetime that the FA service will allow in any Registration Request message from the mobile node.</p> <p>The lifetime is expressed in seconds and can be configured between 1 and 65534. An infinite registration lifetime can be configured by disabling the timer. The default is 600 seconds.</p>

Required Information	Description
Registration reply timeout	<p>Specifies the amount of time that the FA service will wait for a Registration Reply from an HA.</p> <p>The time is measured in seconds and can be configured to any integer value between 1 and 65535. The default is 7.</p>
Number of simultaneous registrations	<p>Specifies the number of simultaneous Mobile IP sessions that will be supported for a single subscriber.</p> <p>The maximum number of sessions is 3. The default is 1.</p> <p>Important The system will only support multiple Mobile IP sessions per subscriber if the subscriber's mobile node has a static IP address.</p>
Mobile node re-registration requirements	<p>Specifies how the system should handle authentication for mobile node re-registrations.</p> <p>The FA service can be configured to always require authentication or not. If not, the initial registration and de-registration will still be handled normally.</p>
HA service Configuration	
HA service name	<p>This is an identification string between 1 and 63 characters (alpha and/or numeric) by which the HA service will be recognized by the system.</p> <p>Multiple names are needed if multiple HA services will be used.</p> <p>HA services are configured in the destination context.</p>
UDP port number for Mobile IP traffic	<p>Specifies the port used by the HA service and the FA for communications. The UDP port number can be any integer value between 1 and 65535. The default value is 434.</p>

Required Information	Description
Mobile node re-registration requirements	<p>Specifies how the system should handle authentication for mobile node re-registrations.</p> <p>The HA service can be configured as follows:</p> <ul style="list-style-type: none"> • Always require authentication • Never require authentication (NOTE: the initial registration and de-registration will still be handled normally) • Never look for mn-aaa extension • Not require authentication but will authenticate if mn-aaa extension present
FA-to-HA Security Parameter Index Information	<p>FA IP address:</p> <p>The HA service allows the creation of a security profile that can be associated with a particular FA. This specifies the IP address of the FA that the HA service will be communicating with. Multiple FA addresses are needed if the HA will be communicating with multiple FAs.</p> <hr/> <p>Index:</p> <p>Specifies the shared SPI between the HA service and a particular FA. The SPI can be configured to any integer value between 256 and 4294967295. Multiple SPIs can be configured if the HA service is to communicate with multiple FAs.</p> <hr/> <p>Secret:</p> <p>Specifies the shared SPI secret between the HA service and the FA. The secret can be between 1 and 127 characters (alpha and/or numeric). An SPI secret is required for each SPI configured.</p> <hr/> <p>Hash-algorithm:</p> <p>Specifies the algorithm used to hash the SPI and SPI secret. The possible algorithms that can be configured are MD5 per RFC 1321 and keyed-MD5 per RFC 2002. The default algorithm is hmac-md5. A hash-algorithm is required for each SPI configured.</p>

Required Information	Description
Mobile Node Security Parameter Index Information	<p>Index:</p> <p>Specifies the shared SPI between the HA service and the mobile node(s). The SPI can be configured to any integer value between 256 and 4294967295.</p> <p>Multiple SPIs can be configured if the HA service is to communicate with multiple mobile nodes.</p> <p>Secret(s):</p> <p>Specifies the shared SPI secret between the HA service and the mobile node. The secret can be between 1 and 127 characters (alpha and/or numeric).</p> <p>An SPI secret is required for each SPI configured.</p> <p>Hash-algorithm:</p> <p>Specifies the algorithm used to hash the SPI and SPI secret. The possible algorithms that can be configured are MD5 per RFC 1321 and keyed-MD5 per RFC 2002. The default algorithm is hmac-md5.</p> <p>A hash-algorithm is required for each SPI configured.</p> <p>Replay-protection process:</p> <p>Specifies how protection against replay-attacks is implemented. The possible processes are nonce and timestamp. The default is timestamp with a tolerance of 60 seconds.</p> <p>A replay-protection process is required for each mobile node-to-HA SPI configured.</p>
Maximum registration lifetime	<p>Specifies the longest registration lifetime that the HA service will allow in any Registration Request message from the mobile node.</p> <p>The time is measured in seconds and can be configured to any integer value between 1 and 65535. An infinite registration lifetime can also be configured by disabling the timer. The default is 600.</p>
Maximum number of simultaneous bindings	<p>Specifies the maximum number of "care-of" addresses that can simultaneously be bound for the same user as identified by NAI and Home address.</p> <p>The number can be configured to any integer value between 1 and 5. The default is 3.</p>
Default Subscriber Configuration	

Required Information	Description
"Default" subscriber's IP context name	<p>Specifies the name of the egress context on the system that facilitates the PDN ports.</p> <p>Important For this configuration, the IP context name should be identical to the name of the destination context.</p>

Simple IP Destination Context

The following table lists the information that is required to configure the optional destination context. As discussed previously, This context is only required if Reverse Tunneling is disabled in the FA service.

Table 26: Required Information for Destination Context Configuration

Required Information	Description
Destination context name	<p>This is an identification string between 1 and 79 characters (alpha and/or numeric) by which the destination context will be recognized by the system.</p> <p>Important For this configuration, the destination context name should not match the domain name of a specific domain.</p>
PDN Interface Configuration	
PDN interface name	<p>This is an identification string between 1 and 79 characters (alpha and/or numeric) by which the interface will be recognized by the system.</p> <p>Multiple names are needed if multiple interfaces will be configured.</p> <p>PDN interfaces are configured in the destination context.</p>
IP address and subnet	<p>These will be assigned to the PDN interface.</p> <p>Multiple addresses and/or subnets are needed if multiple interfaces will be configured.</p>
Physical port number	<p>This specifies the physical port to which the interface will be bound. Ports are identified by the chassis slot number where the line card resides in, followed by the number of the physical connector on the line card. For example, port 17/1 identifies connector number 1 on the card in slot 17.</p> <p>A single physical port can facilitate multiple interfaces.</p>

Required Information	Description
Physical port description	<p>This is an identification string between 1 and 79 characters (alpha and/or numeric) by which the physical port will be recognized by the system.</p> <p>Multiple descriptions are needed if multiple ports will be used.</p> <p>Physical ports are configured within the destination context and are used to bind logical PDN interfaces.</p>
Gateway IP address(es)	Used when configuring static routes from the PDN interface(s) to a specific network.
IP Address Pool Configuration (optional)	
IP address pool name	<p>Each IP address pool is identified by a name. The pool name can be between 1 and 31 alpha and/or numeric characters and is case sensitive.</p> <p>IP address pools are configured in the destination context(s). Multiple address pools can be configured within a single context.</p>
IP pool addresses	<p>An initial address and a subnet, or a starting address and an ending address, are required for each configured pool. The pool will then consist of every possible address within the subnet, or all addresses from the starting address to the ending address.</p> <p>The pool can be configured as public, private, or static.</p>

System-Level AAA Parameter Configuration

The following table lists the information that is required to configure the system-level AAA parameters.

Table 27: Required Information for System-Level AAA Configuration

Required Information	Description
Subscriber default domain name	<p>Specifies the name of a context that can provide AAA functions in the event that the domain-part of the username is missing or poorly formed.</p> <p>This parameter will be applied to all subscribers if their domain can not be determined from their username regardless of what domain they are trying to access.</p> <p>Important The default domain name can be the same as the source context.</p>

Required Information	Description
Subscriber Last-resort context	<p>Specifies the name of a context that can provide AAA functions in the event that the domain-part of the username was present but does not match the name of a configured destination context.</p> <p>This parameter will be applied to all subscribers if their specified domain does not match a configured destination context regardless of what domain they are trying to access.</p> <p>Important The last-resort context name can be the same as the source context.</p>
Subscriber username format	<p>Specifies the format of subscriber usernames as to whether or not the username or domain is specified first and the character that separates them. The possible separator characters are:</p> <ul style="list-style-type: none"> • @ • % • - • \ • # • / <p>Up to six username formats can be specified. The default is <i>username @</i>.</p> <p>Important The username string is searched from right to left for the separator character. Therefore, if there is one or more separator characters in the string, only the first one that is recognized is considered the actual separator. For example, if the default username format was used, then for the username string <i>user1@enterprise@isp1</i>, the system resolves to the username <i>user1@enterprise</i> with domain <i>isp1</i>.</p>

How This Configuration Works

The following figure and the text that follows describe how this configuration with a single source and destination context would be used by the system to process a Simple IP data call.

Figure 24: Call Processing When Using the System as a PDSN, FA, and HA

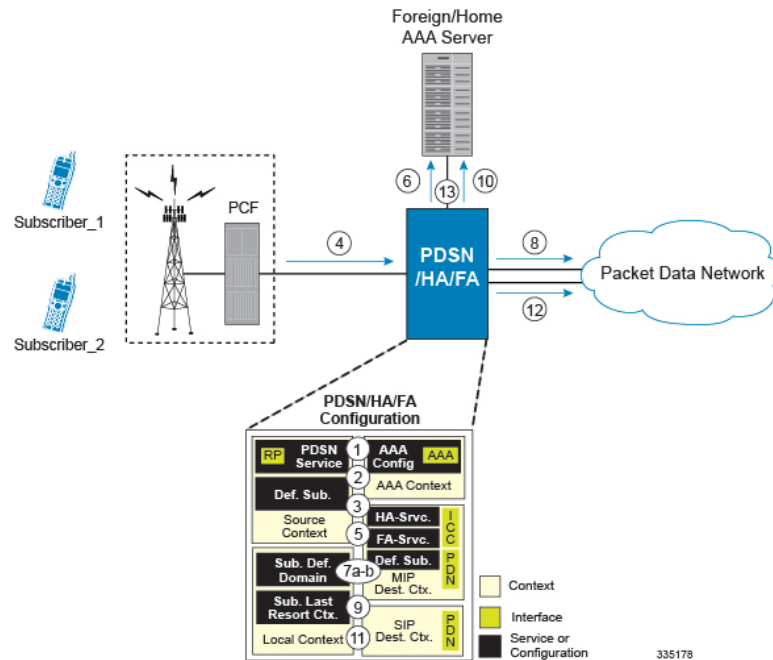

In this example, *Subscriber1* is establishing a Simple IP data session, while *Subscriber2* is establishing a Mobile IP data session.

- The system-level AAA settings were configured as follows:
 - Default domain name = AAA
 - Subscriber username format = *username @*
 - Last-resort context name = AAA
- The Default Subscriber was configured with an IP context name of *SIP Destination*.
- The Mobile IP FA context name parameter within the PDSN service was configured to the *MIP Destination* context.
- Sessions for *Subscriber1* and *Subscriber2* are received by the PDSN service over the R-P interface from the PCF.
- The PDSN service determines which context to use to provide foreign AAA functionality for each session. This process is described in the How the System Selects Contexts section located in the Understanding the System Operation and Configuration chapter of the *System Administration Guide*.
 For this configuration, the result of this process for both *Subscriber1* and *Subscriber2* would be that the system determines that AAA functionality should be provided by the AAA context.
- The system would then communicate with the AAA server specified in the AAA context's AAA configuration to authenticate the subscribers.
- Upon successful authentication, the PDSN service will take the following actions for *Subscriber1* and *Subscriber2*:

- a. *Subscriber1*: The system will go through the process of determining which destination context to use for the subscriber session. This process is described in the How the System Selects Contexts section located in the Understanding the System Operation and Configuration chapter of the *System Administration Guide*. For this configuration, the system determines that the egress context is the *SIP Destination* context based on the configuration of the *Default* subscriber in the *Source* context.
 - b. *Subscriber2*: The system uses the Mobile IP FA context name configured within the PDSN service to determine what destination context facilitates the FA service. In this example, it determines that it must use the *MIP Destination* context and it passes the HA IP address to the FA service.
8. For *Subscriber1's* session, data traffic would then be routed through the PDN interface in the *SIP Destination* context.
9. For *Subscriber2*, the FA service then establishes a connection to the specified HA service through the ICC interface.
10. For *Subscriber2*, the system would then communicate with the AAA server specified in the AAA context's AAA configuration to authenticate the subscriber.
11. For *Subscriber2*, upon successful authentication, the *MIP Destination* context determines which destination context to use for the session and Mobile IP registration would be completed. This process is described in the How the System Selects Contexts section located in the Understanding the System Operation and Configuration chapter of the *System Administration Guide*.

For this example, the *Source* context determines that the egress context is the *MIP Destination* context based on the configuration of the *Default* subscriber.
12. For *Subscriber2's* session, data traffic would then be routed through the PDN interface in the *MIP Destination* context.
13. Accounting messages for both sessions would be sent to the AAA server over the AAA interface in the AAA context.



CHAPTER 6

Service Configuration Procedures

This chapter is meant to be used in conjunction with the previous chapters that provide examples for configuring the system to support Simple IP services, Mobile IP services, or both. It provides procedures for configuring the various elements to support these services.

It is recommended that you first select the configuration example that best meets your service model, and then use the procedures in this chapter to configure the required elements for that model.



Important

This manual is valid for configuring PDSN on multiple platforms. Consequently not all sections, descriptions, features and commands are supported on all platforms. Others are activated by license only.



Important

For hardware supporting them, at least onepacket processing card must be made active prior to service configuration. Information and instructions for configuring active cards can be found in the "Configuring System Settings" chapter of the *System Administration Guide*.

The following topics are included:

- [Configuring PDSN Closed R-P Services, on page 153](#)
- [Creating and Configuring PDSN Services, on page 155](#)
- [Creating and Configuring FA Services, on page 157](#)
- [Creating and Configuring HA Services, on page 160](#)
- [Configuring IP Address Pools on the System, on page 162](#)

Configuring PDSN Closed R-P Services

PDSN Closed R-P services are configured within contexts and allow the system to function as a PDSN in 3G wireless data networks that implement the proprietary Closed R-P protocol from Nortel Networks®.



Important

A valid feature license must be installed prior to configuring PDSN Closed R-P services. This section provides the minimum instruction set for configuring a Closed R-P service that allows the system to process data sessions. Commands that configure additional Closed R-P service properties are provided in the *Command Line Interface Reference*.

Use this example to configure PDSN Closed R-P services:

```
configure
context <name>
pdsnclosedrpservice <name>
peer-pcf <ipv4/ipv6_address> | <ipv4_address/ipv6_address/mask>
bind address <interface_address>
authentication
nai-construction domain <domain_name>
end
```

- Optionally configure the accounting start/stop RRQ generation during intra-PDSN handoff, by entering the **accounting peer-pcf handoff** command. If disabled, accounting start/stop RRQs are not generated for the Closed R-P to Closed R-P handoff between two PCFs, which are within the same PCF address range as configured in **peer-pcf** configuration. By default it is enabled.
- Repeat this example as needed to create and bind additional PDSN Closed R-P services to any other interfaces.
- Save your configuration to flash memory, an external memory device, and/or a network location using the Exec mode command **save configuration**. For additional information on how to verify and save configuration files, refer to the *System Administration Guide* and the *Command Line Interface Reference*.

Following are a few items to be aware of:

- Since a Closed-RP service uses the R-P interface as an ingress (arriving) interface to receive incoming sessions and session requests from PCFs, this service type must reside in a source context.
- Up to 10000 peer PCFs can be configured for each Closed R-P Service.



Important

The Closed R-P service must not be bound to the same ip address of an interface as other L2TP LAC or LNS services.

Verifying your Configuration

Use the following command to verify the Closed R-P configuration:

```
show pdsnclosedrpservice name service_name
```

The output of this command should be similar to the output shown in the following example.

```
Service name: closedrp-1
Context:                pdsn
Bind:                   Done
Local IP Address:       192.168.2.20
First Retransmission Timeout: 1 (secs)
Max Retransmission Timeout: 8 (secs)
Max Retransmissions:    5
Max Sessions:           500000      Max Tunnels: 10000
Max Sessions Per Tunnel: 65535
Keep-alive interval:    60          Control receive window: 16
Data Sequence Numbers: Disabled
PPP Authentication:     CHAP 1 PAP 2
Allow Noauthentication: Disabled     MSID Authentication: Disabled
No Default Subscriber defined
```

```

PPP Tunnel Type:           None
PPP Tunnel Context:       <NONE DEFINED>
MIP FA Context:           <NONE DEFINED>
Service Status:           Started
Newcall Policy:           None

```

Creating and Configuring PDSN Services

PDSN services are configured within contexts and allow the system to function as a PDSN in the 3G wireless data network.



Important

This section provides the minimum instruction set for configuring a PDSN service that allows the system to process data sessions. Commands that configure additional PDSN service properties are provided in the *Command Line Interface Reference*.

Use this example to configure PDSN services:

```

configure
context <name>
pdsn-service <name>
ip local-port <port>
authentication allow-noauth
authentication chap 1 mschap 2 pap 3 allow-noauth
nai-construct domain <alias>
spi remote-address <pcf_ipv4_address/pcf_ipv6_address/mask> spi-number <number> {
secret <secret> }
lifetime <time>
gre protocol-type { any | byte-stream | ppp }
bind address address
exit
ppp lcp-start-delay <seconds>
no ppp renegotiation retain-ip-address
end

```

Notes:

- Optional: If you are implementing Mobile IP data services, configure the name of the context in which the FA service is configured by entering the **mobile-ip foreign-agent context fa_context_name [fa-service <name>]** command.
- Optionally configure the PDSN service to monitor all PCFs that it is associated with, enter the **pcf-monitor** command.
- Optionally configure the PDSN behavior for A11 RRQ related parameters. **airlink bad-sequence-number deny** can be used to deny A11 RRQ messages that have an unsupported Vendor Id or invalid Airlink Sequence number (less than or equal to a previously received sequence number). Keywords and options that configure additional PDSN service behavior for A11 RRQs with this command are provided in the *Command Line Interface Reference*.
- Optionally use the **no dormant-transition initial-session-setup** command to configure the PDSN behavior to terminate A10 session, when the PDSN receives the A11-RRQ (Type 4) before the session for the original MN is established completely.

- Optionally use the **no pcf-session-id-change restart-ppp** command to configure the PDSN behavior to disable the ppp renegotiation, when the PDSN receives the A11 RRQ (Type 4) with a change in GRE key or PCF session Id, from current PCF and no change in PCF/PANID/CANID.
- Optionally use the **setup-timeout**<seconds> command to change the maximum amount of time, in seconds, allowed to set up a session. The default setting is 60 seconds.
- Optionally configure a delay before starting LCP to avoid the first LCP Configuration Request being lost because the RP link may not be ready even if it has indicated it is active. Losing an LCP Config Request increases the total session setup time.
- Optional: You can configure the system whether to retain the currently allocated IP address for the session or to release the current IP address, and a new IP address is to allocate after PPP renegotiation.
- To retain the allocated IP during PPP renegotiation use the **[default] ppp renegotiation retain-ip-address** command



Important By default it will use the same IP address, allocated during renegotiation, after renegotiation also. Detailed informations are provided in the *Command Line Interface Reference*.

- Optionally configure the MSID length to reject the A11-RRQs with illegal IMSI value by entering the **[default] msid length [min min_length] max max_length** command:
By default it will use the default MSID length as per standard. Detailed informations are provided in the *Command Line Interface Reference*.
- The nai-construct domain command should only be used if the PDSN service is configured to allow no authentication using the authentication allow-noauth command.
- Multiple SPIs can be configured within the PDSN service in order to accommodate a single PDSN interface communicating with multiple PCFs.
- An infinite lifetime can be configured using the no lifetime command.
- Multiple addresses on the same IP interface can be bound to different PDSN services. However, each address can be bound to only one PDSN service.
- The hardware configuration and features installed can affect the maximum subscriber sessions that can be supported.
- Repeat this configuration as needed to create and bind additional PDSN services to any other interfaces.
- Save your configuration to flash memory, an external memory device, and/or a network location using the Exec mode command **save configuration**. For additional information on how to verify and save configuration files, refer to the *System Administration Guide* and the *Command Line Interface Reference*.

Verifying the PDSN Services

Step 1 Use the following command to verify that the PDSN service was created and configured properly:

```
show pdsn-service { name service_name | all }
```

The output is a concise listing of PDSN service parameter settings as shown in the sample output below. In this example, a PDSN service called `pdsn1` was configured.

```
Service name: pdsn1
Context: test1
Bind:                Not Done
Local IP Address:    0.0.0.0           Local IP Port:        699
Lifetime:           00h30m00s        Retransmission Timeout: 3 (secs)
Max Retransmissions: 5                Setup Timeout        : 60 (secs)
No MIP FA Context defined
No NAI construct domain defined
GRE Sequence Numbers: Enabled         GRE Protocol Type:    Any
GRE Reorder Timeout: 100 msec         GRE Sequence Mode:    None
GRE Checksum: Disabled                GRE Checksum Verification: Disabled
Enable Data Available Indicator: Yes   Inter-PDSN handoffs have MEI: No
Reg discard on bad extension: No       Reg discard on GRE key change: No
Reg ack deny terminates session: No    Reg update wait timeout: No
Deny newcall if no rev. tunnel: No
Terminate session on R-P errors: No    Max retried replies on reg deny: 3
Deny using zero GRE key: No           Deny if session already closed: No
Deny if session already dormant: No    Deny if session already active: No
Deny if CoA & src addr mismatch: No
Deny newcall if no conn setup: No     (Deny code: Reason Unspecified)
RRQ with bad airlink seq num: No       Accept (Deny code: Poorly Formed Request)
Deny if CRP to RP H/O in progress: No
Handoff with no conn setup: Accept
Accept H/O if sess being disc: No
PPP Authentication: CHAP 1 PAP 2
Allow Noauthentication: Disabled       MSID Authentication: Disabled
Fragment PPP Data: Enabled
GRE Flow Control: Disabled
GRE Flow Control Timeout: 10000 msec
GRE Flow Control Timeout Action: disconnect-session
Max sessions: 500000
Alt-PPP: Disabled
PPP Tunnel Type: None                  No PPP Tunnel Context defined
No Default Subscriber defined
IP SRC-Violation Reneg Limit: 5        IP SRC-Violation Drop Limit: 10
IP SRC-Violation Clear-on-ValidPDU: No IP SRC-Violation Period: 120 secs
Always-On-Indication: Disabled        SDB Indication for Echo Req: Disabled
SPI(s):
Service Status: Not started
Overload Policy: Reject (Reject code: Admin Prohibited)
Newcall Policy: None
Service Option Policy: Enforce
Service Options: 7,15,22,23,24,25,33,59
PCF Monitor Config: Disabled
```

Step 2 Verify configuration for errors by entering the following command:

```
show configuration errors section pdsn-service verbose | more
```

Creating and Configuring FA Services

FA services are configured within contexts and allow the system to function as an FA in the 3G wireless data network.

**Important**

This section provides the minimum instruction set for configuring an FA service that allows the system to process data sessions. Commands that configure additional FA service properties are provided in the *Command Line Interface Reference*. Additionally, when configuring Mobile IP take into account the MIP timing considerations discussed in the Appendix *MIP Timer Considerations*.

Use this example to create and/or configure FA services:

```
configure
context <name>
fa-service <name>
ip local-port <port>

fa-ha-spi remote-address <ipv4_address/ipv6_address>|<ipv4/ipv6_address/mask
spi-number number
{ encrypted secret secret | secret secret }
advertise adv-lifetime <time>
advertise num-adv-sent <number>
advertise reg-lifetime <reg_time>
multiple-reg <number>
authentication mn-aaa { always | ignore-after-handoff | init-reg |
init-reg-except-handoff | renew-and-dereg-noauth | renew-reg-noauth }
reg-timeout time
bind address ipv4_address max-subscribers max
end
```

Following are a few things to be aware of:

- The **ip local-port** command configures the User Datagram Protocol (UDP) port for the Pi interfaces' IP socket.
- A maximum of 2048 FA-HA SPIs can be configured for a single FA service.
- The agent advertisement lifetime is the amount of time that an FA agent advertisement remains valid in the absence of further advertisements.
- An infinite registration lifetime can be configured using the **no advertise reg-lifetime** command.
- The system only supports multiple Mobile IP sessions per subscriber if the subscriber's mobile node has a static IP address. The system only allows a single Mobile IP session for mobile nodes that receive a dynamically assigned home IP address. The hardware configuration and features installed can affect the maximum subscriber sessions that can be supported.
- Optionally configure the FA service for controlling the negotiation and sending of the I-bit in revocation messages by adding the **revocation negotiate-i-bit** command. By default, it will not send I-bit in revocation message.
- Repeat the configuration as needed to create and bind additional FA services to any other interfaces.

Verifying the FA Service

Step 1 Verify that your FA services were created and configured properly by entering the following command:

```
show fa-service { name service_name | all }
```

The output is a concise listing of FA service parameter settings similar the sample displayed below. In this example, a FA service called fal was configured.

```
Service name:      fal
Context:          xxx
  Bind:           Done           Max Subscribers:    500000
Local IP Address: 195.20.20.3    Local IP Port:      434
Lifetime:        00h10m00s     Registration Timeout: 45 (secs)
Advt Lifetime:   02h30m00s     Advt Interval:      5000 (msecs)
Num Advt:        5
Advt Prefix Length Extn: NO
Reverse Tunnel:  Enabled       GRE Encapsulation:  Enabled
Optimize Tunnel Reassembly: Disabled Allow Priv Addr w/o Rev Tunnel: Disabled
Dynamic MIP Key Update: Enabled Ignore Dynamic MIP Key: Disabled
Remove MN-AAA/MN-FAC extns: Disabled
Proxy MIP:       Enabled       Proxy MIP Max Retransmissions: 5
Proxy MIP Retrans Timeout: 3 (secs) Proxy MIP Renew Percent Time: 75
SPI(s):
  FAHA: Remote Addr: 195.30.30.3/32
    Hash Algorithm:  HMAC_MD5      SPI Num: 1000
    Replay Protection: Timestamp   Timestamp Tolerance: 60
  FAHA: Remote Addr: 195.30.30.2/32
    Hash Algorithm:  HMAC_MD5      SPI Num: 1000
    Replay Protection: Timestamp   Timestamp Tolerance: 60
  FAHA: Remote Addr: 195.30.30.1/32
    Hash Algorithm:  HMAC_MD5      SPI Num: 1000
    Replay Protection: Timestamp   Timestamp Tolerance: 60
  FAHA: Remote Addr: 195.20.20.4/32
    Hash Algorithm:  HMAC_MD5      SPI Num: 1000
    Replay Protection: Timestamp   Timestamp Tolerance: 60
IPSEC Crypto Map(s):
  Peer HA Addr:      195.30.30.2
  Crypto Map:       test
GRE Sequence Numbers: Disabled GRE Sequence Mode: None
GRE Reorder Timeout: 100 msec
GRE Checksum:       Disabled GRE Checksum Verification: Disabled
  Registration Revocation: Enabled Reg-Revocation I bit: Enabled
Reg-Revocation Max Retries: 3      Reg-Revocation Timeout: 3 (secs)
Reg-Rev on InternalFailure: Enabled
Default Subscriber: None
Max sessions:       500000
Max challenge len:  16
Challenge Window:   2
Service Status:     Started
MN-AAA Auth Policy: Always
MN-HA Auth Policy:  Always
Newcall Policy:     None
Idle Timeout Mode:  Normal
Ignore Stale Challenge: Disabled
```

Step 2

Save your configuration to flash memory, an external memory device, and/or a network location using the Exec mode command **save configuration**. For additional information on how to verify and save configuration files, refer to the *System Administration Guide* and the *Command Line Interface Reference*.

Creating and Configuring HA Services

HA services are configured within contexts and allow the system to function as an HA in the 3G wireless data network.



Note This section provides the minimum instruction set for configuring an HA service that allows the system to process data sessions. Commands that configure additional HA service properties are provided in the *Command Line Interface Reference*. Additionally, when configuring Mobile IP take into account the MIP timing considerations discussed in *MIP Timer Considerations*.

Use this example to create and/or configure HA services:

```
configure
context <name>
    ha-service <name>
ip local-port <port>
authentication mn-aaa { allow-noauth | always | noauth | renew-reg-noauth
}
fa-ha-spi remote-address <ipv4/ipv6_address > | <ipv4/ipv6_address/mask> spi-number
<number> { [encrypted] secret <secret> }
mn-ha-spi spi-number <number> { encrypted secret <secret> | secret
<secret> }
reg-lifetime <time>
simultaneous-bindings <number>
bind address <ipv4_address> max-subscribers <max>
end
```

Following are a few things to be aware of:

- The **ip local-port** command configures the User Datagram Protocol (UDP) port for the Pi interfaces' IP socket.
- A maximum of 2048 FA-HA SPIs can be configured for each HA service.
- An infinite registration lifetime can be configured using the **no reg-lifetime** command.
- The hardware configuration and features installed can affect the maximum subscriber sessions that can be supported.
- Optionally configure the HA service for controlling the negotiation and sending of the I-bit in revocation messages by adding the **revocation negotiate-i-bit** command. By default it will not send I-bit in revocation message.
- Optionally change the maximum amount of time, in seconds, allowed to set up a session. The default setting is 60 seconds. To change this value add the **setup-timeout seconds** command.
- Repeat the configuration as needed to create and bind additional HA services to any other interfaces.

Verifying the HA Service

Step 1 Verify that your HA services were created and configured properly by entering the following command:

```
show ha-service { name service_name | all }
```

The output is a concise listing of HA service parameter settings. In this example, a HA service called ha1 was configured.

```
Service name: ha1
Context: ha
Bind: Done Max Subscribers: 500000
Local IP Address: 192.168.4.10 Local IP Port: 434
Lifetime: 00h10m00s Simul Bindings: 3
Reverse Tunnel: Enabled GRE Encapsulation: Enabled
Optimize Tunnel Reassembly: Enabled Setup Timeout: 60 sec
SPI(s):
MNHA: Remote Addr: 0.0.0.0
Hash Algorithm: MD5 SPI Num: 1000
Replay Protection: Timestamp Timestamp Tolerance: 60
Permit Any Hash Algorithm: Disabled
FAHA: Remote Addr: 195.20.20.6/32
Hash Algorithm: HMAC_MD5 SPI Num: 1000
Replay Protection: Timestamp Timestamp Tolerance: 60
FAHA: Remote Addr: 195.20.20.5/32
Hash Algorithm: HMAC_MD5 SPI Num: 1000
Replay Protection: Timestamp Timestamp Tolerance: 60
FAHA: Remote Addr: 195.20.20.3/32
Hash Algorithm: HMAC_MD5 SPI Num: 1000
Replay Protection: Timestamp Timestamp Tolerance: 60
FAHA: Remote Addr: 195.20.20.2/32
Hash Algorithm: HMAC_MD5 SPI Num: 1000
Replay Protection: Timestamp Timestamp Tolerance: 60
IPSEC Crypto Map(s):
Peer FA Addr: 192.168.4.1
Crypto Map: test
'S' Key expires at: No Valid S-Key
'S' Lifetime Skew: 00h00m10s
IPSEC AAA Context: xxx
GRE Sequence Numbers: Disabled GRE Sequence Mode: None
GRE Reorder Timeout: 100 msec
GRE Checksum: Disabled GRE Checksum Verification: Disabled
Registration Revocation: Enabled Reg-Revocation I bit: Enabled
Reg-Revocation Max Retries: 3 Reg-Revocation Timeout: 3 (secs)
Reg-Rev Handoff old-FA: Enabled Reg-Rev Idle-Timeout: Enabled
Default Subscriber: None
Max Sessions: 500000
Service Status: Started
MN-AAA Auth Policy: Always
MN-HA Auth Policy: Always
IMSI Auth: Disabled
AAA accounting: Enabled
Idle Timeout Mode: Aggressive
Newcall Policy: None
Overload Policy: Reject (Reject code: Admin Prohibited)
NW-Reachability Policy: Reject (Reject code: Admin Prohibited)
```

Step 2 Save your configuration to flash memory, an external memory device, and/or a network location using the Exec mode command **save configuration**. For additional information on how to verify and save configuration files, refer to the *System Administration Guide* and the *Command Line Interface Reference*.

Configuring IP Address Pools on the System

One of the steps in establishing a PPP session between the mobile and the PDSN service running on the system is that upon successful authentication, the subscriber's mobile node is assigned an IP address. The IP address could be dynamically assigned from a pool that is configured on the system or on the AAA server. It may also be an address that is statically configured in the user profile or even one that is requested by the subscriber.

IP addresses can be dynamically assigned from a single pool/a group of IP pools/a group of IP pool groups. The addresses/IP pools/ IP pool groups are placed into a queue in each pool or pool group. An address is assigned from the head of the queue and, when released, returned to the end. This method is known as least recently used (LRU).

When a group of pools have the same priority, an algorithm is used to determine a probability for each pool based on the number of available addresses, then a pool is chosen based on the probability. This method, over time, allocates addresses evenly from the group of pools.



Important

Note that setting different priorities on each individual pool can cause addresses in some pools to be used more frequently.

To configure the IP pool:

- Create the IP pool for IPv4 addresses in system context by applying the example configuration.
- Optional. Configure the IP pool for IPv6 addresses in system context by applying the example.
- Optional. Configure the overlap-pool addresses to routing by applying the example configuration.
- Verify your IP pool configuration.
- Save your configuration to flash memory, an external memory device, and/or a network location using the Exec mode command **save configuration**. For additional information on how to verify and save configuration files, refer to the *System Administration Guide* and the *Command Line Interface Reference*.

Creating IPv4 Pool

Use the following example to create the IPv4 address pool:

```
configure
context <dest_ctxt_name>
ip pool <pool_name> <ipv4/ipv6_address|ipv4/ipv6_address/mask>
end
```

Following are a few things to be aware of:

- To ensure proper operation, IP pools should be configured within a destination context.
- Each address in the pool requires approximately 24 bytes of memory. Therefore, in order to conserve available memory, the number of pools may need to be limited depending on the number of addresses to be configured and the number of PACs/PSCs installed.
- Setting different priorities on individual pools can cause addresses in some pools to be used more frequently.

- For more information on commands/keywords that configure additional parameters and options, refer `ipv6 pool` command section in the "Context Configuration Mode Commands" chapter of the *Command Line Interface Reference*.

Creating IPv6 Pool

Use the following example to create the IPv6 address pool:

```
configure
context <dest_ctxt_name>
ipv6 pool <pool_name> 6to4 local-endpoint <ipv4/ipv6_address>
end
```

Following are a few things to be aware of:

- To ensure proper operation, IP pools should be configured within a destination context.
- Each address in the pool requires approximately 24 bytes of memory. Therefore, in order to conserve available memory, the number of pools may need to be limited depending on the number of addresses to be configured and the number of PACs/PSCs installed.
- Setting different priorities on individual pools can cause addresses in some pools to be used more frequently.
- For more information on commands/keywords that configure additional parameters and options, refer `ipv6 pool` command section in the "Context Configuration Mode Commands" chapter of the *Command Line Interface Reference*.

Adding Overlap-Pool Addresses to Routing

Use the following configuration to advertise overlap-pool addresses in dynamic routing protocols.

```
configure
context <context_name>
[ no | default ] ip routing overlap-pool
```

If `ip routing overlap-pool` is configured, then the overlap addresses are added as interface addresses in the routing stack and a route is added in the kernel. The intf-address in the routing stack and the route in the kernel for the overlap address are removed when all the overlap-pools are deleted. The default is **no ip routing overlap-pool**.

Verifying IP Pool Configuration

Step 1 Verify that your IPv4 address pool configured properly by entering the following command in Exec Mode:

```
show ip pool
```

The output from this command should look similar to the sample shown below. In this example all IP pools were configured in the `isp1` context.

```
context : isp1:
+-----Type:      (P) - Public      (R) - Private
|                  (S) - Static      (E) - Resource
```

```

|
|+----State:   (G) - Good      (D) - Pending Delete   (R)-Resizing
||
||+---Priority: 0..10 (Highest (0) .. Lowest (10))
||||
||||+---Busyout: (B) - Busyout configured
|||||
|||||
vvvvv Pool Name Start Address   Mask/End Address Used      Avail
-----
PG00 ipsec          12.12.12.0      255.255.255.0   0        254
RG00 pool3        30.30.0.0       255.255.0.0    0        65534
SG00 pool2        20.20.0.0       255.255.0.0    10       65524
PG00 pool1        10.10.0.0       255.255.0.0    0        65534
SG00 vpnpool      192.168.1.250   192.168.1.254  0         5
Total Pool Count: 5

```

Step 2 Verify that your IPv6 address pools configured properly by entering the following command in Exec Mode:

```
show ipv6 pools
```

The output from this command should look similar to the sample shown above except IPv6 addresses.



CHAPTER 7

Monitoring the Service

This chapter provides information for monitoring service status and performance using the **show** commands found in the Command Line Interface (CLI). These commands have many related keywords that allow them to provide useful information on all aspects of the system ranging from current software configuration through call activity and status.

The selection of keywords described in this chapter is intended to provide the most useful and in-depth information for monitoring the system. For additional information on these and other **show** command keywords, refer to the *Command Line Interface Reference*.

In addition to the CLI, the system supports the sending of Simple Network Management Protocol (SNMP) traps that indicate status and alarm conditions. Refer to the *SNMP MIB Reference Guide* for a detailed listing of these traps.

This chapter includes the following topics:

- [Monitoring System Status and Performance, on page 165](#)
- [Clearing Statistics and Counters, on page 169](#)

Monitoring System Status and Performance

This section contains commands used to monitor the status of tasks, managers, applications and other software components in the system. Output descriptions for most of the commands are located in the *Statistics and Counters Reference*.

Table 28: System Status and Performance Monitoring Commands

To do this:	Enter this command:
View Congestion-Control Statistics	
View Congestion-Control Statistics	show congestion-control statistics { a11mgr gtpcmgr hamgr l2tpmgr }
View Subscriber Information	
View session resource status	show resources session
Display Subscriber Configuration Information	
View locally configured subscriber profile settings (must be in context where subscriber resides)	show subscribers configuration username <i>subscriber_name</i>

To do this:	Enter this command:
View remotely configured subscriber profile settings	show subscribers aaa-configuration username <i>subscriber_name</i>
View Subscribers Currently Accessing the System	
View a listing of subscribers currently accessing the system	show subscribers all
Display PCF-Summary Session Counters	
View PCF-summary session counters	show session counters pcf-summary
Display Session State Statistics	
View session state statistics	show session progress
Display Session State PCF Statistics	
View session state PCF statistics	show session progress pcf all
Display Session Subsystem and Task Statistics Important Refer to the System Software Task and Subsystem Descriptions appendix in the System Administration Guide for additional information on the Session subsystem and its various manager tasks.	
View A11 Manager statistics	show session subsystem facility a11mgr all
View AAA Manager statistics	show session subsystem facility aaamgr all
View FA Manager statistics	show session subsystem facility famgr all
View L2TP demux manager statistics	show session subsystem facility l2tpdemux all
View L2TP Manager statistics	show session subsystem facility l2tpmgr all
View Session Manager statistics	show session subsystem facility sessmgr all
View Session Recovery Status	
View session recovery status	show session recovery status [verbose]
Display Session Disconnect Reasons	
View session disconnect reasons with verbose output	show session disconnect-reasons
View Point-to-Point Protocol Statistics	
Display a Summary of PPP Counter Status	
View cumulative subscriber session PPP counters	show ppp
Display PPP Counters for a Specific Subscriber	
View individual subscriber session PPP counters	show ppp username <i>subscriber_name</i>
View individual subscriber session PPP error and data counters	show ppp counters username <i>subscriber_name</i>

To do this:	Enter this command:
View individual subscriber session detailed PPP counters	show ppp full username <i>subscriber_name</i>
Display PPP Statistics for PDSN Services	
Views PPP statistics for a all PDSN services	show ppp statistics pdsn-service
Views PPP statistics for a specific PDSN service	show ppp statistics pdsn-service <i>service_name</i>
View R-P Interface Statistics	
Display a Summary of R-P Interface Counter Status	
View cumulative R-P interface counters for every subscriber session currently in progress	show rp
Display R-P Interface Counters for a Specific Subscriber	
View R-P interface counters for a specific subscriber	show rp full username <i>subscriber_name</i>
Display R-P Interface Statistics for PDSN Services	
View R-P interface statistics for all PDSN services	show rp statistics pdsn-service
View R-P interface statistics for a specific PDSN service	show rp statistics pdsn-service <i>service_name</i>
View Mobile IP Foreign Agent Statistics	
Display Mobile IP FA Information for a Specific Subscriber	
View Mobile IP FA counters for a specific subscriber	show mipfa full username <i>subscriber_name</i>
Display Mobile IP Statistics for FA Services	
View statistics for a specific FA service	show mipfa statistics fa-service <i>service_name</i>
Display Mobile IP FA Counters	
View Mobile IP FA counters for individual subscriber sessions	show mipfa counters
Display RADIUS Server States Important These commands can display 10 state transition histories of RADIUS accounting and authentication servers (Active/Not responding/Down States). For a complete explanation of RADIUS server states, refer to the RADIUS Server State Behavior appendix in the AAA Administration and Reference.	
View RADIUS authentication server group server states for a specific group	show radius authentication servers radius group <i>group_name</i> detail

To do this:	Enter this command:
View RADIUS accounting server group server states for a specific group	show radius accounting servers radius group group_name detail
Display RADIUS Protocol Counters	
View cumulative RADIUS protocol counters	show radius counters all
View RADIUS protocol counter summary of RADIUS authentication and accounting	show radius counters summary
View L2TP Information	
Display L2TP Session Information	
View cumulative statistics for all sessions processed within the current context Important If this command is executed from within the localout-of-band context, cumulative session information is displayed for all contexts.	show l2tp sessions
View all information pertaining to the L2TP session of a specific subscriber	show l2tp session full username subscriber_name
Display L2TP Statistics	
View statistics for a specific LAC service Important If this command is executed from within the localout-of-band context, cumulative session information is displayed for all contexts.	show l2tp statistics lac-service service_name
Display L2TP Tunnel Information	
View all tunnels currently being facilitated by LAC services within a specific context	show l2tp tunnels all
Display IPSec Security Association Statistics	
View IPSec security association statistics for crypto maps in the current context	show crypto ipsec security-associations statistics
Display Pre-shared ISAKMP Keys	
View pre-shared keys received from peer security gateways as part of the Diffie-Hellman exchange	show crypto isakmp keys
Display IPSec Statistics	
View cumulative IPSec statistics for the current context	show crypto statistics

Clearing Statistics and Counters

It may be necessary to periodically clear statistics and counters in order to gather new information. The system provides the ability to clear statistics and counters based on their grouping (PPP, MIPHA, MIPFA, etc.).

Statistics and counters can be cleared using the CLI **clear** command. Refer to the *Command Line Interface Reference* for detailed information on using this command.



CHAPTER 8

Troubleshooting the System

This chapter provides information and instructions for using the system command line interface (CLI) for troubleshooting any issues that may arise during system operation.

- [Test Commands, on page 171](#)

Test Commands

In the event that an issue was discovered with an installed application or line card, depending on the severity, it may be necessary to take corrective action.

The system provides several redundancy and fail-over mechanisms to address issues with application and line cards in order to minimize system downtime and data loss. These mechanisms are described below.

Using the PPP Echo-Test Command

The system provides a mechanism to verify the Point-to-Point Protocol session of a particular subscriber by sending Link Control Protocol (LCP) packets to the mobile node. This functionality can be extremely useful in determining the quality of the air link and delays that may occur.

The command has the following syntax:

```
ppp echo-test { callid call_id | ipaddr ipv4_address | msid ms_id | username subscriber_name }
```

Keyword/Variable	Description
callid <i>call_id</i>	Specifies that the test is executed for a subscriber with a specific call identification number (callid). <i>call_id</i> is the specific call identification number that you wish to test.
ipaddr <i>ip_address</i>	Specifies that the test is executed for a subscriber with a specific IP address. <i>ipv4_address</i> is the specific IPV4 address that you wish to test.
msid <i>ms_id</i>	Specifies that the test is executed for a subscriber with a specific mobile station identification (MSID) number. <i>ms_id</i> is the specific mobile station identification number that you wish to test.

Keyword/Variable	Description
<code>username</code> <i>subscriber_name</i>	Specifies that the test is executed for a subscriber with a specific username. <i>subscriber_name</i> is the specific username that you wish to test.

**Important**

For descriptions of the keywords and variables, see the *CLI Reference Guide*.

The following displays a sample of this command's output showing a successful PPP echo-test to a subscriber named *user2aaa*.

```

USERNAME: user2aaa  MSID: 0000012345  CALLID: 001e8481
Tx/Rx 1/0  RTT (min/max/avg) 0/0/0
USERNAME: user2aaa  MSID: 0000012345  CALLID: 001e8481
Tx/Rx 1/1  RTT (min/max/avg) 77/77/77 (COMPLETE)

```



APPENDIX **A**

Engineering Rules

This section provides engineering rules or guidelines that must be considered prior to configuring the system for your network deployment.

- [Interface and Port Rules, on page 173](#)
- [Subscriber Rules, on page 175](#)
- [Service Rules, on page 175](#)

Interface and Port Rules

The rules discussed in this section pertain to the Ethernet 10/100 line card, the Ethernet 1000 line card and the four-port Quad Gig-E line card and the type of interfaces they facilitate, regardless of the application.

R-P Interface Rules

The following engineering rules apply to the R-P interface:

- An R-P interface is created once the IP address of a logical interface is bound to a PDSN service.
- The logical interface(s) that will be used to facilitate the R-P interface(s) must be configured within an "ingress" context.
- PDSN services must be configured within an "ingress" context.
- At least one PDSN service must be bound to each interface; however, multiple PDSN services can be bound to a single interface if secondary addresses are assigned to the interface.
- Each PDSN service must be configured with the Security Parameter Index (SPI) of the Packet Control Function (PCF) that it will be communicating with over the R-P interface.
- Multiple SPIs can be configured within the PDSN service to allow communications with multiple PCFs over the R-P interface. It is best to define SPIs using a netmask to specify a range of addresses rather than entering separate SPIs. This assumes that the network is physically designed to allow this communication.
- Depending on the services offered to the subscriber, the number of sessions facilitated by the R-P interface can be limited.

Closed R-P Interface Rules

The following engineering rules apply to the Closed R-P interface:

- A Closed R-P interface is created once the IP address of a logical interface is bound to a Closed R-P service.
- The logical interface(s) that will be used to facilitate the Closed R-P interface(s) must be configured within an "ingress" context.
- Closed R-P services must be configured within an "ingress" context.
- Up to 64 Closed R-P services may be configured system wide. All 64 Closed R-P services may be configured in one context.
- At least one Closed R-P service must be bound to each interface; however, multiple Closed R-P services can be bound to a single interface.
- The Closed R-P service must not be bound to the same ip address of an interface as other L2TP LAC or LNS services.
- Each Closed R-P service must be configured with the Peer PCF address of the Packet Control Function (PCF) that it will be communicating with over the Closed R-P interface.
- Multiple Peer PCFs can be configured within the Closed R-P service to allow communications with multiple PCFs over the Closed R-P interface. This assumes that the network is physically designed to allow this communication.
- Depending on the services offered to the subscriber, the number of sessions facilitated by the Closed R-P interface can be limited.

Pi Interface Rules

FA to HA Rules

When supporting Mobile IP, the system can be configured to perform the role of a FA, an HA, or both. This section describes the engineering rules for the Pi interface when using the system as a FA.

The following engineering rules apply to the Pi interface between the FA and HA:

- A Pi interface is created once the IP address of a logical interface is bound to an FA service.
- The logical interface(s) that will be used to facilitate the Pi interface(s) must be configured within the egress context.
- FA services must be configured within the egress context.
- If the system is configured as a FA is communicating with a system configured as an HA, then it is recommended that the name of the context in which the FA service is configured is identical to the name of the context that the HA service is configured in on the other system.
- Each FA service may be configured with the Security Parameter Index (SPI) of the HA that it will be communicating with over the Pi interface.

- Multiple SPIs can be configured within the FA service to allow communications with multiple HAs over the Pi interface. It is best to define SPIs using a netmask to specify a range of addresses rather than entering separate SPIs. This assumes that the network is physically designed to allow this communication.
- Depending on the services offered to the subscriber, the number of sessions facilitated by the Pi interface can be limited.

HA to FA

The following engineering rules apply to the Pi interface between the HA and FA:

- When supporting Mobile IP, the system can be configured to perform the role of a FA, an HA or both. This section describes the engineering rules for the Pi interface when using the system as an HA.
- A Pi interface is created once the IP address of a logical interface is bound to an HA service.
- The logical interface(s) that will be used to facilitate the Pi interface(s) must be configured within an ingress context.
- HA services must be configured within an ingress context.
- If the system configured as an HA is communicating with a system configured as a FA, then it is recommended that the name of the context in which the HA service is configured is identical to the name of the context that the FA service is configured in on the other system.
- Each HA service may be configured with the Security Parameter Index (SPI) of the FA that it will be communicating with over the Pi interface.
- Multiple SPIs can be configured within the HA service to allow communications with multiple FAs over the Pi interface. It is best to define SPIs using a netmask to specify a range of addresses rather than entering separate SPIs. This assumes that the network is physically designed to allow this communication.
- Each HA service must be configured with a Security Parameter Index (SPI) that it will share with mobile nodes.
- Depending on the services offered to the subscriber, the number of sessions facilitated by the Pi interface can be limited in order to allow higher bandwidth per subscriber.

Subscriber Rules

The following engineering rule applies to subscribers configured within the system:

- A maximum of 2,048 local subscribers can be configured per context.
- Default subscriber templates may be configured on a per PDSN or FA service.

Service Rules

The following engineering rules apply to services configured within the system:

- A maximum of 256 services (regardless of type) can be configured per system.



Caution Large numbers of services greatly increase the complexity of management and may impact overall system performance (i.e. resulting from such things as system handoffs). Therefore, it is recommended that a large number of services only be configured if your application absolutely requires it. Please contact your local service representative for more information.

- Up to 2,048 Security Parameter Indices (SPIs) can be configured for a single PDSN service.
- Up to 2,048 MN-HA and 2048 FA-HA SPIs can be supported for a single HA service.
- Up to 2,048 FA-HA SPIs can be supported for a single FA service.
- The system supports unlimited peer FA addresses per HA.
 - The system maintains statistics for a maximum of 8192 peer FAs per HA service.
 - If more than 8192 FAs are attached, older statistics are identified and overwritten.
- The system maintains statistics for a maximum of 4096 peer HAs per FA service.
- There are a maximum of 8 HA assignment tables per context and per chassis.
- The total number of entries per table and per chassis is limited to 256.
- Up to 10,000 LAC addresses can be configured per LNS service.
- Even though service names can be identical to those configured in different contexts on the same system, this is not a good practice. Having services with the same name can lead to confusion, difficulty troubleshooting problems, and make it difficult understanding outputs of show commands.
- Up to 10,000 PCF addresses can be configured per PDSN ClosedRP service.
- Up to 64 Closed R-P services may be configured system wide. All 64 Closed R-P services may be configured in one context.



APPENDIX B

Supported Registration Reply Codes

Each of the sections that follow describe the registration reply codes supported by the system for the PDSN and FA services.

- [PDSN Service Reply Codes, on page 177](#)
- [FA Service Reply Codes, on page 178](#)

PDSN Service Reply Codes

The following registration reply codes are supported by the system's PDSN service in accordance with the *3GPP2 A.S0001-A v2: 3GPP2 Access Network Interfaces Interoperability Specification* (also known as *3G-IOS v4.1.1*).

Table 29: Supported PDSN Service Registration Reply Codes

Reply Code (Hex / Base 10)	Description	Notes
00H / 0	Registration Accepted	Sent when the subscriber session is successfully set up.
80H / 128	Registration Denied - reason unspecified	Sent when internal errors are encountered when processing the Request packet.
81H / 129	Registration Denied - administratively prohibited	Sent when a newcall policy is set to reject.
82H / 130	Registration Denied - insufficient resources	Sent when no memory or session managers are available to process the session.
83H / 131	Registration Denied - mobile node failed authentication	Sent when the mobile node failed authentication. When multiple errors occur on authentication this message takes precedence and is listed first.

Reply Code (Hex / Base 10)	Description	Notes
85H / 133	Registration Denied - identification mismatch	Sent when the PCF's timestamp does not match the PDSN. The PDSN sends a corrected timestamp to be used as the ID by the PCF in subsequent requests.
86H / 134	Registration Denied - poorly formed request	Sent when an unsupported Service option is received or the packet is malformed in any way.
88H / 136	Registration Denied - unknown PDSN address	Sent when PDSN redirect policy is invoked.
89H / 137	Registration Denied - requested reverse tunnel unavailable	Sent when reverse tunneling is requested by the mobile node but it is not enabled on the system.
8AH / 138	Registration Denied - reverse tunnel is mandatory and 'T' bit not set	Sent when reverse tunneling is enabled on the system but is not supported by the mobile node.
8DH / 139	Registration Denied - unsupported vendor ID or unable to interpret data in the CVSE	Sent when the Airlink records from the PCF contain a Vendor ID value other than 0x159F or the Accounting VSE contains an Application Sub Type other than RADIUS or the Request contains a Critical Vendor Specific Extension Type that is not recognized by the PDSN.

FA Service Reply Codes

The following registration reply codes are supported by the system's FA service in accordance with the following Request For Comments (RFCs):

- RFC-2002, IPv4 Mobility, May 1995
- RFC-2344, Reverse Tunneling for Mobile IP, May 1998
- RFC-2794, Mobile IP Network Access Identifier Extension for IPv4, March 2000
- RFC-3012, Mobile IPv4 Challenge/Response Extensions, November 2000

Table 30: Supported FA Service Registration Reply Codes

Reply Code (Hex / Base 10)	Description	Notes
40H / 64	Registration Denied - reason unspecified	Sent when internal errors are encountered when processing the Request packet.
41H / 65	Registration Denied - administratively prohibited	Sent when a newcall policy is set to reject calls or the subscriber is not permitted to use Mobile IP FA services.
42H / 66	Registration Denied - insufficient resources	Sent when no memory or session managers are available to process the session.
43H / 67	Registration Denied - mobile node failed authentication	Sent when the mobile node failed authentication.
44H / 68	Registration Denied - home agent failed authentication	Sent when an HA attempted to communicate with the FA service using an incorrect security parameter index (SPI).
45H / 69	Registration Denied - requested lifetime too long	Sent when the mobile node requests a registration lifetime longer than the maximum supported by the FA.
46H / 70	Registration Denied - poorly formed request	Sent when the registration request is poorly formed (i.e. missing an Authentication extension).
47H / 71	Registration Denied - poorly formed reply	Sent when the registration reply is poorly formed (i.e. missing an Authentication extension).
48H / 72	Registration Denied - requested encapsulation unavailable	Sent when requested encapsulation type is unavailable (GRE or minimal IP encapsulation).
4AH / 74	Registration Denied - reverse tunneling unavailable	Sent when reverse tunneling is requested by the mobile node but it is not enabled on the system.
4BH / 75	Registration Denied - reverse tunneling mandatory	Sent when reverse tunneling is enabled on the system but is not supported by the mobile node.
4CH / 76	Registration Denied - reverse tunneling mobile node too distant	Sent when IP TTL is not set to 255 in Reg Request with T bit set
4DH / 77	Registration Denied - invalid care-of address	Sent when D bit is set in the Registration Request.

Reply Code (Hex / Base 10)	Description	Notes
4EH / 78	Registration Denied - registration timeout	Sent when FA reg-timeout is exceeded.
4FH / 79	Registration Denied - reverse tunneling delivery style unavailable	Sent if the Encapsulating Delivery Style Extension sent by the mobile is not supported by the FA service.
50H / 80	Registration Denied - home network unreachable (ICMP error received)	Sent when the FA service can not contact the home network due to an Internet Control Message Protocol (ICMP) error.
51H / 81	Registration Denied - home agent host unreachable (ICMP error received)	Sent when the FA service can not contact the HA host due to an Internet Control Message Protocol (ICMP) error.
52H / 82	Registration Denied - home agent port unreachable (ICMP error received)	Sent when the FA service can not contact the HA port due to an Internet Control Message Protocol (ICMP) error.
58H / 88	Registration Denied - home agent unreachable (other ICMP error received)	Sent when the FA service can not contact the HA due to an Internet Control Message Protocol (ICMP) error.
60H / 96	Registration Denied - missing home address	Sent when the FA service could not determine the IP address of the mobile node.
61H / 97	Registration Denied - missing NAI	Sent when the FA service could not determine the subscriber's network access identifier.
62H / 98	Registration Denied - missing home agent	Sent when the FA service could not determine the IP address of the mobile node's home agent.
68H / 104	Registration Denied - unknown challenge	Sent if the FA cannot validate the Mobile IP mobile-to-foreign agent advertisement challenge extension provided in the Registration Request.
69H / 105	Registration Denied - missing challenge	Sent if the mobile node's Registration Request does not include a mobile-to-foreign agent advertisement challenge extension.

Reply Code (Hex / Base 10)	Description	Notes
6AH / 106	Registration Denied - stale challenge	Sent when the mobile node has sent a Registration Request with a challenge value that was already used before.



APPENDIX **C**

Mobile-IP and Proxy-MIP Timer Considerations

This section is intended to provide a brief explanation of the considerations for lifetime, idle, and absolute timer settings that must be understood when setting up a system in a mobile IP or proxy mobile IP environment. In the Cisco ASR 5500 platform, there is not an explicitly defined MIP lifetime. The MIP lifetime is determined through various timers settings in the configuration and through radius attributes returned in an Access-Accept message.

This chapter contains the following topics:

- [Call Flow Summary, on page 183](#)
- [Dealing with the 'Requested Lifetime Too Long' Error Code, on page 185](#)
- [Controlling the Mobile IP Lifetime on a Per-Domain Basis, on page 185](#)

Call Flow Summary

The following steps describe the call flow as regards the timers that affect a call initiated by the Mobile Node (MN).

1. **PPP Negotiation:** A data call is initiated by beginning PPP. Once PPP is successfully established, the system will understand if the call is a mobile IP call or simple IP call. At this point, the system is not aware of the subscriber username and will use settings from the default subscriber template in the source context or the context defined by the "aaa default-domain subscriber" setting in the global configuration.
2. **FA Agent Advertisement:** Once the system has determined the call is a Mobile IP call, the FA will send a Router Advertisement message with a Mobility Agent Advertisement extension. The Mobility Agent Advertisement includes a Registration Lifetime field. The value of this field will come from one of two places. The FA service has a configurable setting named "advertise reg-lifetime". The default value for this setting is 600. A setting in the default subscriber template called "timeout idle" is also a candidate. The default value for this setting is 0 (null). The smaller of these two configurable parameters is used as the Registration Lifetime value. Leaving the settings at the defaults will result in an advertised lifetime of 600.

Advertise Reg-Lifetime in FA Service	Timeout Idle in Subscriber Template	Resulting Advertised Registration Lifetime
600	0	600
600	900	600
3600	1200	1200

The device will receive the agent advertisement and send a MIP Registration Request. The device uses the advertised registration lifetime value as the requested MIP lifetime.

- 3. AAA Authentication and MIP Registration Request:** The next step in the MIP process will be to authenticate the user at the FA. It is at this stage where a failure condition can be introduced.

If the Access-Accept message does not return any values related to timers, the subscribers MIP Registration Request is sent on to the HA.

If the Access-Accept message does include an attribute relating to Idle or Absolute timer the FA will evaluate the requested lifetime from the device to the value returned by the AAA. The FA will treat any Idle or Absolute timer value returned by the AAA as a maximum value and as such:

- If the requested MIP lifetime from the device is less-than than the returned radius attribute, the lifetime value is considered valid and the MIP Registration Request is forwarded on to the HA.
- If the requested MIP lifetime from the device is greater-than the returned radius attribute, the requested lifetime value is considered to be too long. The FA will send a MIP Registration Reply to the device with a response code of Error 69 - Requested Lifetime Too Long. In the reply message, the FA will populate the Lifetime value with the maximum acceptable lifetime. The device may send a new MIP request with this new lifetime value.

MIP Lifetime Requested by Device	Idle-Timer Value in Access-Accept	Resulting MIP Lifetime Request in MIP Request to HA
3600	(Not Returned)	3600
3600	7200	3600
3600	1800	Failure - Error 69

- 4. HA Process MIP Request:** The HA has now received a Mobile IP Registration request forwarded by the FA on behalf of the device. The MIP request contains the username and the requested lifetime (as well as other parameters). The HA will take this lifetime request and compare it to the configurable parameters associated with the HA service and associated configurations. The HA will use the username to determine which subscriber template to use for subscriber specific settings.

The parameters the HA uses to determine the MIP lifetime are the requested lifetime, the "reg-lifetime" setting in the HA service and the "timeout idle" setting in the subscriber template. If the requested MIP lifetime is lower it is be sent back to the mobile; if the MIP lifetime is higher the system sends back an RRQ accept with the lifetime set to 5 seconds less than the lower of the idle or absolute timeout for the user.

MIP Lifetime Requested by Device	Timeout Idle/Absolute in Subscriber Template	Reg-Lifetime Value in HA Service	MIP Lifetime Returned to Mobile Device
3600	0(default)	7200	3600
3600	7200	1805	1800
3600	1705	3600	1700

PDSN/FA			HA		
Advertise Reg-Lifetime in FA Service	Timeout Idle/Absolute in Subsc. Template (Source Context)	Idle-Timer Value in Access-Accept	Timeout Idle/Absolute in Subscriber Template(HA Context)	Reg-Lifetime Value in HA Service	Resulting Lifetime Value sent to Mobile Device
600	0(default)	(not returned)	0(default)	7200	600
1800	900	7200	7200	1805	900
3600	1200	3600	1705	3600	1200
1500	3600	1500	0(default)	3600	1500
3600	0(default)	(not returned)	0(default)	2405	2400
3600	0(default)	(not returned)	2005	3600	2000
65534	0(default)	7200	0(default)	3600	Lifetime Too Long

Dealing with the 'Requested Lifetime Too Long' Error Code

In some configurations, a roaming partner may return an "Idler-Timer" attribute in an access-accept whose value is smaller than what a carrier may have configured for its own subscribers. This will result in a "Requested Lifetime Too Long" error message being returned to the device. There are several ways to correct this. One is to use a setting in the FA service configuration. Using the "no limit-reg-lifetime" in the FA service configuration will tell the FA service to allow the MIP lifetime to be greater than the Idle or Absolute timers. The FA will not send Error 69 and continue to process the call. The lifetime value in the MIP Request sent to the HA will still be what was determined in Phase 2.

Controlling the Mobile IP Lifetime on a Per-Domain Basis

The system does not support the configuration of the MIP lifetime timer on per-domain (context) basis. However, a domain-wide lifetime timer can be achieved by configuring the idle-timeout attribute for the default subscriber for each domain.



Important

Mobile IP lifetime settings can be controlled on a per-domain basis **only** in deployments for which the idle timeout attribute for individual subscriber profiles is **not** used during operation.

In this configuration, the value of the registration lifetime sent by the system in Agent Advertisements is selected by comparing the configured FA Agent Advertisement lifetime setting, and the idle and/or absolute timeout settings configured for the domain's default subscriber. If the value of the idle and/or absolute timeout parameter is less than the Agent Advertisement lifetime, then the system provides a registration lifetime equal to 5 seconds less than the lowest timer value.

If the idle timeout attribute is configured in individual subscriber profiles, per-domain lifetime control is not possible. In this case, the registration lifetime configured for the FA must be the lower of the two values.



Important

Commands used in the examples in this section provide base functionality to the extent that the most common or likely commands and/or keyword options are presented. In many cases, other optional commands and/or keyword options are available. Refer to the *Command Line Interface Reference* for complete information regarding all commands.

The following is an example CLI command sequence used to configure the Mobile IP lifetime on a per-domain basis.

configure

```

context <aaa_context_name>
  subscriber default
    ip context-name <abc>
    exit
  subscriber name <ptt.bigco.com>
    timeout idle <3605>
    ip context-name <abc>
    exit
  subscriber name <bigco.com>
    timeout idle <7205>
    ip context-name <abc>
    exit
  domain <ptt.bigco.com> default subscriber <ptt.bigco.com>
  domain <bigco.com> default subscriber <bigco.com>
end

```

configure

```

context <ha_context_name>
  subscriber default
  exit
ha-service <ha>
  idle-timeout-mode normal
  reg-lifetime <7200>
end

```

configure

```

context <fa_context_name>
  fa-service <fa>
    advertise reg-lifetime <7200>
  end

```

In the example above, two domains (ptt.bigco.com and bigco.com) are configured. The default subscribers are defined for the two domains respectively. The desired operation requires a Mobile IP lifetime of 1 hour (3600 secs) for the ptt.bigco.com domain, and a lifetime of 2 hours (7200 secs) for the bigco.com domain.

Whenever a subscriber session belonging to the ptt.bigco.com domain arrives, the system uses a Mobile IP lifetime timer value equal to 5 seconds less than the idle timeout configured for the default subscriber because the configured value is less than the registration lifetime value configured for the Agent Advertisement. 5 seconds less than the configured value of 3605 seconds equals 3600 seconds which meets the desired operation.

Whenever a subscriber session belonging to the bigco.com domain arrives, the system uses the configured registration lifetime value as the Mobile IP lifetime in Agent Advertisements because it is less than the configured idle timeout in the default subscriber's profile.

As a general rule, the registration lifetime value on the agent **must** be configured as the highest Mobile IP lifetime that is desired for a subscriber. (In the above example, it would be the subscriber bigco.com.)

Another important factor to consider is that the idle timeout value should be reset on receipt of a renewal request. To support this operation, the system provides the **idle-timeout-mode** configurable in the HA service. The following modes are supported:

- **normal**: Resets the idle timeout value on receipt of Mobile IP user data and control signaling
- **aggressive**: Resets the idle timeout value on receipt of Mobile IP user data only (this is the default behavior)
- **handoff**: Resets the idle timeout value on receipt of Mobile IP user data and upon inter-AGW handoff or inter access technologies

The following optional modifier is also supported:

- **upstream-only**: Only upstream user data (data from the mobile node) resets the idle timer for the session. This is disabled by default.



APPENDIX **D**

Always-on

This chapter provides information on configuring an enhanced, or extended, service. The product Administration Guides provide examples and procedures for configuration of basic services on the system. It is recommended that you select the configuration example that best meets your service model, and configure the required elements for that model, as described in this Administration Guide, before using the procedures in this chapter.

This chapter contains the following topics:

- [Overview, on page 189](#)
- [Configuring Always-on, on page 190](#)

Overview

Always-on is enabled for each subscriber individually through a local subscriber profile or a RADIUS profile. Always-on is disabled for all subscribers by default.

If Always-on is enabled for a subscriber, when the idle time-out limit is reached the subscribers IP/PPP session remains connected as long as the subscriber is reachable. This is true even if the airlink between the mobile device and the RN (Radio Node) is moved from active to dormant (inactive) status. When the idle timeout limit is reached, the PDSN determines Mobile Node availability using LCP keepalive messages. A response to these messages indicates that the "always-on" status should be maintained. Failure to respond to a predetermined number of LCP keepalive messages causes the PDSN to tear-down (disconnect) the subscriber session.



Caution

When always-on is enabled, the subscriber must have an idle time-out period configured (default is 0, no time-out). Failure to configure an idle time-out results in the LCP keepalive messages never being sent and the subscriber session stays up indefinitely.

The RADIUS attribute **3GPP2-Always-On** defined in a subscriber profile stored remotely on a RADIUS server can be used to enable Always-on for the subscriber. The attribute has two possible values, **inactive** and **active**. To enable Always-on, set the attribute to **active**.

For more information on the attributes, if you are using StarOS 12.3 or an earlier release, refer to the *AAA and GTPP Interface Administration and Reference*. If you are using StarOS 14.0 or a later release, refer to the *AAA Interface Administration and Reference*.

Configuring Always-on

To configure Always-on for a subscriber:

-
- Step 1** Configure Always-on as described in the [Configuring Always-on, on page 190](#).
- Step 2** Verify your configuration as described in the [Verifying Your Configuration, on page 191](#).
- Step 3** Save your configuration to flash memory, an external memory device, and/or a network location using the Exec mode command **save configuration**. For additional information on how to verify and save configuration files, refer to the *System Administration Guide* and the *Command Line Interface Reference*.
-

What to do next



Important

Commands used in the configuration examples in this section provide base functionality to the extent that the most common or likely commands and/or keyword options are presented. In many cases, other optional commands and/or keyword options are available. Refer to the *Command Line Interface Reference* for complete information regarding all commands.

Configuring Always-on

Use the following example to configure Always-on:

```
configure
  context <context_name>
    subscriber name <subscriber_name>
    timeout idle <seconds>
    always-on
  end
```

Notes:

- *<context_name>* must be the name of the destination context where the subscriber that you want to enable always-on is configured.
- *Option:* To configure the echo-retransmit-timeout setting to wait before sending a keepalive message to an always-on subscriber, in the Context Configuration Mode, enter the following command:
ppp echo-retransmit-timeout <milliseconds>
- *Option:* To configure the echo-max-retransmissions setting to retransmit a Keepalive message to a subscriber, in the Context Configuration Mode use the following command:
ppp echo-max-retransmissions <num_retries>
- The optional echo-retransmit-timeout and echo-max-retransmissions settings apply to all subscriber sessions within the current context that have always-on enabled.
- *Option:* To configure the long duration timer for the subscriber, in the Subscriber Configuration Mode, enter the following command:

timeout long-duration <ld_timeout> [**inactivity-time** <inact_timeout>]

- *Option:* To configure the long duration timer detection to trigger long duration timer action for the subscriber, in the Subscriber Configuration Mode enter the following command:

long-duration-action detection

- *Option:* To configure the long duration timer action for sessions exceeding the long duration timer timeout or the idle timeout durations for the subscriber, in the Subscriber Configuration Mode enter the following command:

long-duration-action disconnection [**suppress-notification**] [**dormant-only**] +

Verifying Your Configuration

To verify your configuration:

Step 1 Change to the context where Always-on was configured by entering the following command:

```
context <context_name>
```

Step 2 View the subscriber's configuration by entering the following command:

```
show subscriber configuration username <name>
```

Output of the command displays the subscriber's configurations. Examine the output for the idle timeout and always-on fields.



APPENDIX **E**

Broadcast Multicast Service

This chapter provides information on Broadcast Multicast Service (BCMCS) functionality. The product Administration Guides provide examples and procedures for configuration of basic services on the system. It is recommended that you select the configuration example that best meets your service model, and configure the required elements for that model, as described in this Administration Guide, before using the procedures in this chapter.



Important

The features described in this chapter are only available if you have purchased and installed a feature license for Broadcast & Multicast Services.

This chapter contains the following topics:

- [Overview, on page 193](#)
- [Configuring BCMCS, on page 194](#)

Overview

BCMCS eliminates unnecessary replication of data on CDMA2000 wireless networks by transmitting a single stream of data to multiple users. By delivering a single, unidirectional data stream to many subscribers, BCMCS makes more efficient use of wireless network resources than traditional point to point connections.

BCMCS functionality on the system is provided by an existing PDSN service and is enabled by a valid Broadcast & Multicast Services license. In the absence of a valid license, the system functions as a standard unicast PDSN. When a PDSN is functioning in a BCMCS environment, it is designated as a Broadcast Serving Node (BSN). The main features supported by the Broadcast & Multicast Services license are:

- Multicast proxy-host functionality.
- Support for BCMCS-specific A11 messages.
- Authentication of BCMCS flow-IDs using a BCMCS controller.
- Establishment and teardown of BCMCS bearer paths using the multicast framework.
- Support for framing HDLC-like and segment based framing.
- Accounting for the BCMCS flows to charge the originator of the content.

Licensing

The BCMCS is a licensed Cisco feature. A separate feature license may be required. Contact your Cisco account representative for detailed information on specific licensing requirements. For information on installing and verifying licenses, refer to the *Managing License Keys* section of the *Software Management Operations* chapter in the *System Administration Guide*.

Configuring BCMCS

To configure the system for BCMCS:

-
- Step 1** Configure the system for PDSN functionality as described in the this Administration Guide.
 - Step 2** Set the BCMCS group user name and password for RADIUS access as described in the [BCMCS Group Configuration, on page 194](#).
 - Step 3** Create a multicast group profile on your RADIUS server to achieve BCMCS functionality as described in the [RADIUS Server Configuration, on page 194](#).
 - Step 4** Save your configuration to flash memory, an external memory device, and/or a network location using the Exec mode command **save configuration**. For additional information on how to verify and save configuration files, refer to the *System Administration Guide* and the *Command Line Interface Reference*.
-

What to do next



Important

Commands used in the configuration examples in this section provide base functionality to the extent that the most common or likely commands and/or keyword options are presented. In many cases, other optional commands and/or keyword options are available. Refer to the *Command Line Interface Reference* for complete information regarding all commands.

BCMCS Group Configuration

Use the following example to set the BCMCS group user name and password for RADIUS access:

```
configure
context context_name
pdsn-service pdsn_service_name
bcmcs grpusrname group_name
bcmcs grppasswd group_password
end
```

RADIUS Server Configuration

You must create a multicast group profile on your RADIUS server to achieve BCMCS functionality. The group name and password must be the same as configured in [BCMCS Group Configuration, on page 194](#).

For information about the supported BCMCS attributes, refer to the *AAA and GTP Interface Administration and Reference*.



APPENDIX **F**

CoA, RADIUS DM, and Session Redirection (Hotlining)

This chapter describes Change of Authorization (CoA), Disconnect Message (DM), and Session Redirect (Hotlining) support in the system. RADIUS attributes, Access Control Lists (ACLs) and filters that are used to implement these features are discussed. The product administration guides provide examples and procedures for configuration of basic services on the system. It is recommended that you select the configuration example that best meets your service model, and configure the required elements for that model, as described in this Administration Guide, before using the procedures in this chapter.



Important

Not all functions, commands, and keywords/variables are available or supported for all network function or services. This depends on the platform type and the installed license(s).

- [RADIUS Change of Authorization and Disconnect Message, on page 197](#)
- [Session Redirection \(Hotlining\), on page 202](#)

RADIUS Change of Authorization and Disconnect Message

This section describes how the system implements CoA and DM RADIUS messages and how to configure the system to use and respond to CoA and DM messages.

CoA Overview

The system supports CoA messages from the AAA server to change data filters associated with a subscriber session. The CoA request message from the AAA server must contain attributes to identify NAS and the subscriber session and a data filter ID for the data filter to apply to the subscriber session. The filter-id attribute (attribute ID 11) contains the name of an Access Control List (ACL). For detailed information on configuring ACLs, refer to the *IP Access Control Lists* chapter in the *System Administration Guide*.

If the system successfully executes a CoA request, a CoA-ACK message is sent back to the RADIUS server and the data filter is applied to the subscriber session. Otherwise, a CoA-NAK message is sent with an error-cause attribute without making any changes to the subscriber session.



Important Changing ACL and rulebase together in a single CoA is not supported. For this, two separate CoA requests can be sent through AAA server requesting for one attribute change per request.

DM Overview

The DM message is used to disconnect subscriber sessions in the system from a RADIUS server. The DM request message should contain necessary attributes to identify the subscriber session. If the system successfully disconnects the subscriber session, a DM-ACK message is sent back to the RADIUS server, otherwise, a DM-NAK message is sent with proper error reasons.

License Requirements

The RADIUS Change of Authorization (CoA) and Disconnect Message (DM) are licensed Cisco features. A separate feature license may be required. Contact your Cisco account representative for detailed information on specific licensing requirements. For information on installing and verifying licenses, refer to the *Managing License Keys* section of the *Software Management Operations* chapter in the *System Administration Guide*.

Enabling CoA and DM

To enable RADIUS Change of Authorization and Disconnect Message:

-
- Step 1** Enable the system to listen for and respond to CoA and DM messages from the RADIUS server as described in [Enabling CoA and DM, on page 198](#).
 - Step 2** Save your configuration to flash memory, an external memory device, and/or a network location using the Exec mode command **save configuration**. For additional information on how to verify and save configuration files, refer to the *System Administration Guide* and the *Command Line Interface Reference*.
 - Step 3** View CoA and DM message statistics as described in [Viewing CoA and DM Statistics, on page 201](#).

Important Commands used in the configuration examples in this section provide base functionality to the extent that the most common or likely commands and/or keyword options are presented. In many cases, other optional commands and/or keyword options are available. Refer to the *Command Line Interface Reference* for complete information regarding all commands. Not all commands and keywords/variables are available or supported. This depends on the platform type and the installed license(s).

Enabling CoA and DM

Use the following example to enable the system to listen for and respond to CoA and DM messages from the RADIUS server:

```
configure
context <context_name>
radius change-authorize-nas-ip <ipv4/ipv6_address>
end
```

Notes:

- `<context_name>` must be the name of the AAA context where you want to enable CoA and DM.
For more information on configuring the AAA context, if you are using StarOS 12.3 or an earlier release, refer to the *Configuring Context-Level AAA Functionality* section of the *AAA and GTPP Interface Administration and Reference*. If you are using StarOS 14.0 or a later release, refer to the *AAA Interface Administration and Reference*.
- A number of optional keywords and variables are available for the **radius change-authorize-nas-ip** command. For more information regarding this command please refer to the *Command Line Interface Reference*.

CoA and DM Attributes

For CoA and DM messages to be accepted and acted upon, the system and subscriber session to be affected must be identified correctly.

To identify the system, use any one of the following attributes:

- **NAS-IP-Address**: NAS IP address if present in the CoA/DM request should match with the NAS IP address.
- **NAS-Identifier**: If this attribute is present, its value should match to the nas-identifier generated for the subscriber session

To identify the subscriber session, use any one of the following attributes.

- If 3GPP2 service is configured the following attribute is used for correlation identifier:
 - **3GPP2-Correlation-ID**: The values should exactly match the 3GPP2-correlation-id of the subscriber session. This is one of the preferred methods of subscriber session identification.
- If 3GPP service is configured the following attributes are used for different identifiers:
 - **3GPP-IMSI**: International Mobile Subscriber Identification (IMSI) number should be validated and matched with the specified IMSI for specific PDP context.
 - **3GPP-NSAPI**: Network Service Access Point Identifier (NSAPI) should match to the NSAPI specified for specific PDP context.
- **User-Name**: The value should exactly match the subscriber name of the session. This is one of the preferred methods of subscriber session identification.
- **Framed-IP-Address**: The values should exactly match the framed IP address of the session.
- **Calling-station-id**: The value should match the Mobile Station ID.

To specify the ACL to apply to the subscriber session, use the following attribute:

- **Filter-ID**: CoA only. This must be the name of an existing Access Control List. If this is present in a CoA request, the specified ACL is immediately applied to the specified subscriber session. The Context Configuration mode command, **radius attribute filter-id direction**, controls in which direction filters are applied.

The following attributes are also supported:

- Event-Timestamp: This attribute is a timestamp of when the event being logged occurred.
- If 3GPP2 service is configured following additional attributes are supported:
 - 3GPP2-Disconnect-Reason: This attribute indicates the reason for disconnecting the user. This attribute may be present in the RADIUS Disconnect-request Message from the Home Radius server to the PDSN.
 - 3GPP2-Session-Termination-Capability: When CoA and DM are enabled by issuing the radius change-authorize-nas-ip command, this attribute is included in a RADIUS Access-request message to the Home RADIUS server and contains the value 3 to indicate that the system supports both Dynamic authorization with RADIUS and Registration Revocation for Mobile IPv4. The attribute is also included in the RADIUS Access-Accept message and contains the preferred resource management mechanism by the home network, which is used for the session and may include values 1 through 3.

CoA and DM Error-Cause Attribute

The Error-Cause attribute is used to convey the results of requests to the system. This attribute is present when a CoA or DM NAK or ACK message is sent back to the RADIUS server.

The value classes of error causes are as follows:

- 0-199, 300-399 reserved
- 200-299 - successful completion
- 400-499 - errors in RADIUS server
- 500-599 - errors in NAS/Proxy

The following error cause is sent in ACK messages upon successful completion of a CoA or DM request:

- 201- Residual Session Context Removed

The following error causes are sent in NAK messages when a CoA or DM request fails:

- 401 - Unsupported Attribute
- 402 - Missing Attribute
- 403 - NAS Identification Mismatch
- 404 - Invalid Request
- 405 - Unsupported Service
- 406 - Unsupported Extension
- 501 - Administratively Prohibited
- 503 - Session Context Not Found
- 504 - Session Context Not Removable
- 506 - Resources Unavailable

Viewing CoA and DM Statistics

View CoA and DM message statistics by entering the following command:

```
show session subsystem facility aaamgr
```

The following is a sample output of this command.

```

1 AAA Managers
807 Total aaa requests                0 Current aaa requests
379 Total aaa auth requests           0 Current aaa auth requests
    0 Total aaa auth probes           0 Current aaa auth probes
    0 Total aaa auth keepalive        0 Current aaa auth keepalive
426 Total aaa acct requests           0 Current aaa acct requests
    0 Total aaa acct keepalive        0 Current aaa acct keepalive
379 Total aaa auth success            0 Total aaa auth failure
    0 Total aaa auth purged           0 Total aaa auth cancelled
    0 Total auth keepalive success    0 Total auth keepalive failure
    0 Total auth keepalive purged
    0 Total aaa auth DMU challenged
367 Total radius auth requests        0 Current radius auth requests
    2 Total radius auth requests retried
    0 Total radius auth responses dropped
    0 Total local auth requests       0 Current local auth requests
    12 Total pseudo auth requests     0 Current pseudo auth requests
    0 Total null-username auth requests (rejected)
    0 Total aaa acct completed        0 Total aaa acct purged
    0 Total acct keepalive success    0 Total acct keepalive timeout
    0 Total acct keepalive purged
    0 Total aaa acct cancelled
426 Total radius acct requests        0 Current radius acct requests
    0 Total radius acct requests retried
    0 Total radius acct responses dropped
    0 Total gtpv acct requests        0 Current gtpv acct requests
    0 Total gtpv acct cancelled       0 Total gtpv acct purged
    0 Total null acct requests        0 Current null acct requests
    54 Total aaa acct sessions         5 Current aaa acct sessions
    3 Total aaa acct archived         0 Current aaa acct archived
    0 Current recovery archives       0 Current valid recovery records

    2 Total aaa sockets opened        2 Current aaa sockets open
    0 Total aaa requests pend socket open
    0 Current aaa requests pend socket open
    0 Total radius requests pend server max-outstanding
    0 Current radius requests pend server max-outstanding
    0 Total aaa radius coa requests    0 Total aaa radius dm requests
    0 Total aaa radius coa acks       0 Total aaa radius dm acks
    0 Total aaa radius coa naks       0 Total aaa radius dm naks
    2 Total radius charg auth         0 Current radius charg auth
    0 Total radius charg auth succ    0 Total radius charg auth fail
    0 Total radius charg auth purg    0 Total radius charg auth cancel

    0 Total radius charg acct         0 Current radius charg acct
    0 Total radius charg acct succ    0 Total radius charg acct purg
    0 Total radius charg acct cancel
357 Total gtpv charg                  0 Current gtpv charg
357 Total gtpv charg success          0 Total gtpv charg failure
    0 Total gtpv charg cancel         0 Total gtpv charg purg
    0 Total prepaid online requests   0 Current prepaid online requests

    0 Total prepaid online success    0 Current prepaid online failure

    0 Total prepaid online retried    0 Total prepaid online cancelled

```

```

0 Current prepaid online purged
0 Total aaamgr purged requests
0 SGSN: Total db records
0 SGSN: Total sub db records
0 SGSN: Total mm records
0 SGSN: Total pdp records
0 SGSN: Total auth records

```

Session Redirection (Hotlining)



Important Functionality described for this feature in this segment is not applicable for HNB-GW sessions.

Overview

Session redirection provides a means to redirect subscriber traffic to an external server by applying ACL rules to the traffic of an existing or a new subscriber session. The destination address and optionally the destination port of TCP/IP or UDP/IP packets from the subscriber are rewritten so the packet is forwarded to the designated redirected address. Return traffic to the subscriber has the source address and port rewritten to the original values. The redirect ACL may be applied dynamically by means of the RADIUS Change of Authorization (CoA) feature.

Note that the session redirection feature is only intended to redirect a very small subset of subscribers at any given time. The data structures allocated for this feature are kept to the minimum to avoid large memory overhead in the session managers.

License Requirements

The Session Redirection (Hotlining) is a licensed Cisco feature. A separate feature license may be required. Contact your Cisco account representative for detailed information on specific licensing requirements. For information on installing and verifying licenses, refer to the *Managing License Keys* section of the *Software Management Operations* chapter in the *System Administration Guide*.

Operation

ACL Rule

An ACL rule named **readdress server** supports redirection of subscriber sessions. The ACL containing this rule must be configured in the destination context of the user. Only TCP and UDP protocol packets are supported. The ACL rule allows specifying the redirected address and an optional port. The source and destination address and ports (with respect to the traffic originating from the subscriber) may be wildcarded. If the redirected port is not specified, the traffic will be redirected to the same port as the original destination port in the datagrams. For detailed information on configuring ACLs, refer to the *IP Access Control Lists* chapter in the *System Administration Guide*. For more information on **readdress server**, refer to the *ACL Configuration Mode Commands* chapter of the *Command Line Interface Reference*.

Redirecting Subscriber Sessions

An ACL with the **readdress server** rule is applied to an existing subscriber session through CoA messages from the RADIUS server. The CoA message contains the 3GPP2-Correlation-ID, User-Name, Acct-Session-ID, or Framed-IP-Address attributes to identify the subscriber session. The CoA message also contains the Filter-Id attribute which specifies the name of the ACL with the **readdress server** rule. This enables applying the ACL dynamically to existing subscriber sessions. By default, the ACL is applied as both the input and output filter for the matching subscriber unless the Filter-Id in the CoA message bears the prefix **in:** or **out:**.

For information on CoA messages and how they are implemented in the system, refer to [RADIUS Change of Authorization and Disconnect Message, on page 197](#).



Important

Changing ACL and rulebase together in a single CoA is not supported. For this, two separate CoA requests can be sent through AAA server requesting for one attribute change per request.

Session Limits On Redirection

To limit the amount of memory consumed by a session manager a limit of 2000 redirected session entries per session manager is allocated. This limit is equally shared by the set of subscribers who are currently being redirected. Whenever a redirected session entry is subject to revocation from a subscriber due to an insufficient number of available session entries, the least recently used entry is revoked.

Stopping Redirection

The redirected session entries for a subscriber remain active until a CoA message issued from the RADIUS server specifies a filter that does not contain the readdress server ACL rule. When this happens, the redirected session entries for the subscriber are deleted.

All redirected session entries are also deleted when the subscriber disconnects.

Handling IP Fragments

Since TCP/UDP port numbers are part of the redirection mechanism, fragmented IP datagrams must be reassembled before being redirected. Reassembly is particularly necessary when fragments are sent out of order. The session manager performs reassembly of datagrams and reassembly is attempted only when a datagram matches the redirect server ACL rule. To limit memory usage, only up to 10 different datagrams may be concurrently reassembled for a subscriber. Any additional requests cause the oldest datagram being reassembled to be discarded. The reassembly timeout is set to 2 seconds. In addition, the limit on the total number of fragments being reassembled by a session manager is set to 1000. If this limit is reached, the oldest datagram being reassembled in the session manager and its fragment list are discarded. These limits are not configurable.

Recovery

When a session manager dies, the ACL rules are recovered. The session redirect entries have to be re-created when the MN initiates new traffic for the session. Therefore when a crash occurs, traffic from the Internet side is not redirected to the MN.

AAA Accounting

Where destination-based accounting is implemented, traffic from the subscriber is accounted for using the original destination address and not the redirected address.

Viewing the Redirected Session Entries for a Subscriber

View the redirected session entries for a subscriber by entering the following command:

```
show subscribers debug-info { callid <id> | msid <id> | username <name> }
```

The following command displays debug information for a subscriber with the MSID 0000012345:

```
show subscribers debug-info msid 0000012345
```

The following is a sample output of this command:

```
username: user1 callid: 01callb1      msid: 0000100003
Card/Cpu: 4/2
Sessmgr Instance: 7
Primary callline:
Redundancy Status: Original Session
Checkpoints  Attempts  Success  Last-Attempt  Last-Success
  Full:           27         26       15700ms       15700ms
  Micro:          76         76        4200ms        4200ms
Current state: SMGR_STATE_CONNECTED
FSM Event trace:
      State                               Event
SMGR_STATE_OPEN                          SMGR_EVT_NEWCALL
SMGR_STATE_NEWCALL_ARRIVED                SMGR_EVT_ANSWER_CALL
SMGR_STATE_NEWCALL_ANSWERED               SMGR_EVT_LINE_CONNECTED
SMGR_STATE_LINE_CONNECTED                 SMGR_EVT_LINK_CONTROL_UP
SMGR_STATE_LINE_CONNECTED                 SMGR_EVT_AUTH_REQ
SMGR_STATE_LINE_CONNECTED                 SMGR_EVT_IPADDR_ALLOC_SUCCESS
SMGR_STATE_LINE_CONNECTED                 SMGR_EVT_AUTH_SUCCESS
SMGR_STATE_LINE_CONNECTED                 SMGR_EVT_UPDATE_SESS_CONFIG
SMGR_STATE_LINE_CONNECTED                 SMGR_EVT_LOWER_LAYER_UP

Data Reorder statistics
  Total timer expiry:          0          Total flush (tmr expiry):  0
  Total no buffers:            0          Total flush (no buffers):  0
  Total flush (queue full):    0          Total flush (out of range):0
  Total flush (svc change):    0          Total out-of-seq pkt drop: 0
  Total out-of-seq arrived:    0

IPv4 Reassembly Statistics:
  Success:                      0          In Progress:              0
  Failure (timeout):            0          Failure (no buffers):     0
  Failure (other reasons):      0

Redirected Session Entries:
  Allowed:                       2000       Current:                   0
  Added:                          0          Deleted:                   0
  Revoked for use by different subscriber: 0

Peer callline:
Redundancy Status: Original Session
Checkpoints  Attempts  Success  Last-Attempt  Last-Success
  Full:           0         0         0ms           0ms
  Micro:          0         0         0ms           0ms
Current state: SMGR_STATE_CONNECTED
FSM Event trace:
      State                               Event
SMGR_STATE_OPEN                          SMGR_EVT_MAKECALL
SMGR_STATE_MAKECALL_PENDING               SMGR_EVT_LINE_CONNECTED
SMGR_STATE_LINE_CONNECTED                 SMGR_EVT_LOWER_LAYER_UP
SMGR_STATE_CONNECTED                       SMGR_EVT_AUTH_REQ
```

```

SMGR_STATE_CONNECTED          SMGR_EVT_AUTH_SUCCESS
SMGR_STATE_CONNECTED          SMGR_EVT_REQ_SUB_SESSION
SMGR_STATE_CONNECTED          SMGR_EVT_RSP_SUB_SESSION
username: user1 callid: 01callb1    msid: 0000100003
Card/Cpu: 4/2
Sessmgr Instance: 7
Primary callline:
Redundancy Status: Original Session
Checkpoints  Attempts    Success  Last-Attempt  Last-Success
  Full:           27         26       15700ms      15700ms
  Micro:          76         76        4200ms      4200ms
Current state: SMGR_STATE_CONNECTED
FSM Event trace:
State                      Event
SMGR_STATE_OPEN            SMGR_EVT_NEWCALL
SMGR_STATE_NEWCALL_ARRIVED SMGR_EVT_ANSWER_CALL
SMGR_STATE_NEWCALL_ANSWERED SMGR_EVT_LINE_CONNECTED
SMGR_STATE_LINE_CONNECTED  SMGR_EVT_LINK_CONTROL_UP
SMGR_STATE_LINE_CONNECTED  SMGR_EVT_AUTH_REQ
SMGR_STATE_LINE_CONNECTED  SMGR_EVT_IPADDR_ALLOC_SUCCESS
SMGR_STATE_LINE_CONNECTED  SMGR_EVT_AUTH_SUCCESS
SMGR_STATE_LINE_CONNECTED  SMGR_EVT_UPDATE_SESS_CONFIG
SMGR_STATE_LINE_CONNECTED  SMGR_EVT_LOWER_LAYER_UP

Data Reorder statistics
Total timer expiry:      0      Total flush (tmr expiry): 0
Total no buffers:        0      Total flush (no buffers): 0
Total flush (queue full): 0      Total flush (out of range):0
Total flush (svc change): 0      Total out-of-seq pkt drop: 0
Total out-of-seq arrived: 0

IPv4 Reassembly Statistics:
Success:                  0      In Progress:              0
Failure (timeout):        0      Failure (no buffers):    0
Failure (other reasons):  0

Redirected Session Entries:
Allowed:                   2000   Current:                  0
Added:                     0      Deleted:                  0
Revoked for use by different subscriber: 0

Peer callline:
Redundancy Status: Original Session
Checkpoints  Attempts    Success  Last-Attempt  Last-Success
  Full:           0         0         0ms          0ms
  Micro:          0         0         0ms          0ms
Current state: SMGR_STATE_CONNECTED
FSM Event trace:
State                      Event
SMGR_STATE_OPEN            SMGR_EVT_MAKECALL
SMGR_STATE_MAKECALL_PENDING SMGR_EVT_LINE_CONNECTED
SMGR_STATE_LINE_CONNECTED  SMGR_EVT_LOWER_LAYER_UP
SMGR_STATE_CONNECTED       SMGR_EVT_AUTH_REQ
SMGR_STATE_CONNECTED       SMGR_EVT_AUTH_SUCCESS
SMGR_STATE_CONNECTED       SMGR_EVT_REQ_SUB_SESSION
SMGR_STATE_CONNECTED       SMGR_EVT_RSP_SUB_SESSION
SMGR_STATE_CONNECTED       SMGR_EVT_ADD_SUB_SESSION
SMGR_STATE_CONNECTED       SMGR_EVT_AUTH_REQ
SMGR_STATE_CONNECTED       SMGR_EVT_AUTH_SUCCESS

Data Reorder statistics
Total timer expiry:      0      Total flush (tmr expiry): 0
Total no buffers:        0      Total flush (no buffers): 0
Total flush (queue full): 0      Total flush (out of range):0
Total flush (svc change): 0      Total out-of-seq pkt drop: 0
Total out-of-seq arrived: 0

IPv4 Reassembly Statistics:
Success:                  0      In Progress:              0
Failure (timeout):        0      Failure (no buffers):    0

```

```
Failure (other reasons): 0
Redirected Session Entries:
  Allowed:                2000      Current:                0
  Added:                  0         Deleted:                0
  Revoked for use by different subscriber: 0
```



APPENDIX **G**

Gx Interface Support

This chapter provides information on configuring Gx interface to support policy and charging control for subscribers.

The IMS service provides application support for transport of voice, video, and data independent of access support. Roaming IMS subscribers require apart from other functionality sufficient, uninterrupted, consistent, and seamless user experience during an application session. It is also important that a subscriber gets charged only for the resources consumed by the particular IMS application used.

It is recommended that before using the procedures in this chapter you select the configuration example that best meets your service model, and configure the required elements for that model as described in this Administration Guide.

The following topics are covered in this chapter:

- [Rel. 7 Gx Interface, on page 207](#)
- [Rel. 8 Gx Interface, on page 234](#)
- [Rel. 9 Gx Interface, on page 257](#)
- [Rel. 10 Gx Interface, on page 265](#)
- [Supported Gx Features, on page 274](#)

Rel. 7 Gx Interface

Rel. 7 Gx interface support is available on the Cisco ASR chassis running StarOS 8.1 or StarOS 9.0 and later releases for the following products:

- GGSN
- IPSP

This section describes the following topics:

- [Introduction, on page 208](#)
- [Terminology and Definitions, on page 210](#)
- [How Rel. 7 Gx Works, on page 225](#)
- [Configuring Rel. 7 Gx Interface, on page 229](#)
- [Gathering Statistics, on page 234](#)

Introduction

For IMS deployment in GPRS/UMTS networks the system uses Rel. 7 Gx interface for policy-based admission control support and flow-based charging. The Rel. 7 Gx interface supports enforcing policy control features like gating, bandwidth limiting, and so on, and also supports flow-based charging. This is accomplished via dynamically provisioned Policy Control and Charging (PCC) rules. These PCC rules are used to identify Service Data Flows (SDF) and do charging. Other parameters associated with the rules are used to enforce policy control.

The PCC architecture allows operators to perform service-based QoS policy, and flow-based charging control. In the PCC architecture, this is accomplished mainly by the Policy and Charging Enforcement Function (PCEF)/Cisco Systems GGSN and the Policy and Charging Rules Function (PCRF).

In GPRS/UMTS networks, the client functionality lies with the GGSN, therefore in the IMS authorization scenario it is also called the Gateway. In the following figure, Gateway is the Cisco Systems GGSN, and the PCEF function is provided by Enhanced Charging Service (ECS). The Rel 7. Gx interface is implemented as a Diameter connection. The Gx messages mostly involve installing/modifying/removing dynamic rules and activating/deactivating predefined rules.

The Rel. 7 Gx reference point is located between the Gateway and the PCRF. This reference point is used for provisioning and removal of PCC rules from the PCRF to the Gateway, and the transmission of traffic plane events from the Gateway to the PCRF. The Gx reference point can be used for charging control, policy control, or both by applying AVPs relevant to the application. The following figure shows the reference points between various elements involved in the policy and charging architecture.

Figure 25: PCC Logical Architecture

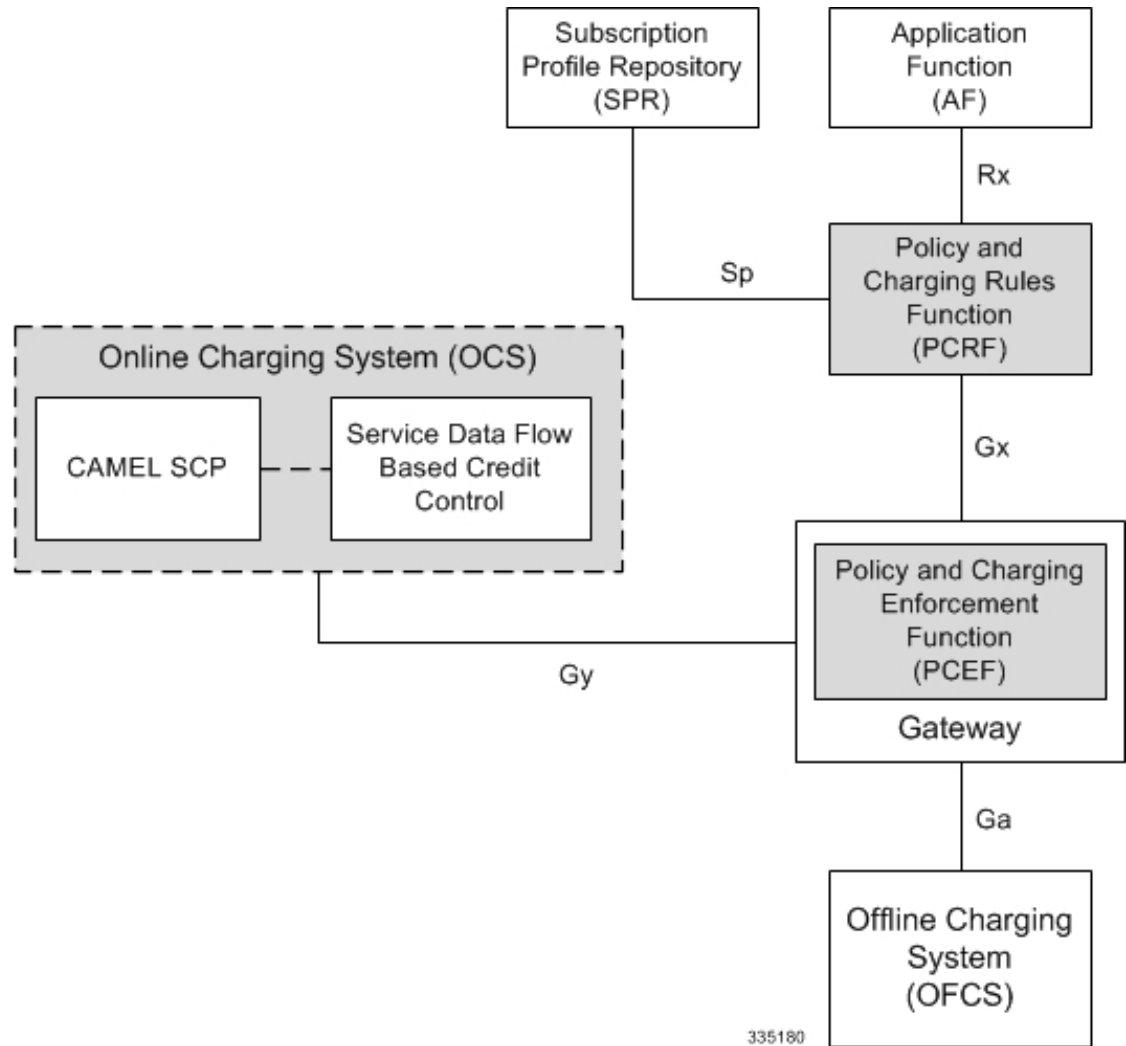

Within the Gateway, the IMSA and DPCA modules handle the Gx protocol related functions (at the SessMgr) and the policy enforcement and charging happens at ECS. The Gy protocol related functions are handled within the DCCA module (at the ECS). The following figure shows the interaction between components within the Gateway.

Figure 26: PCC Architecture within Cisco PCEF

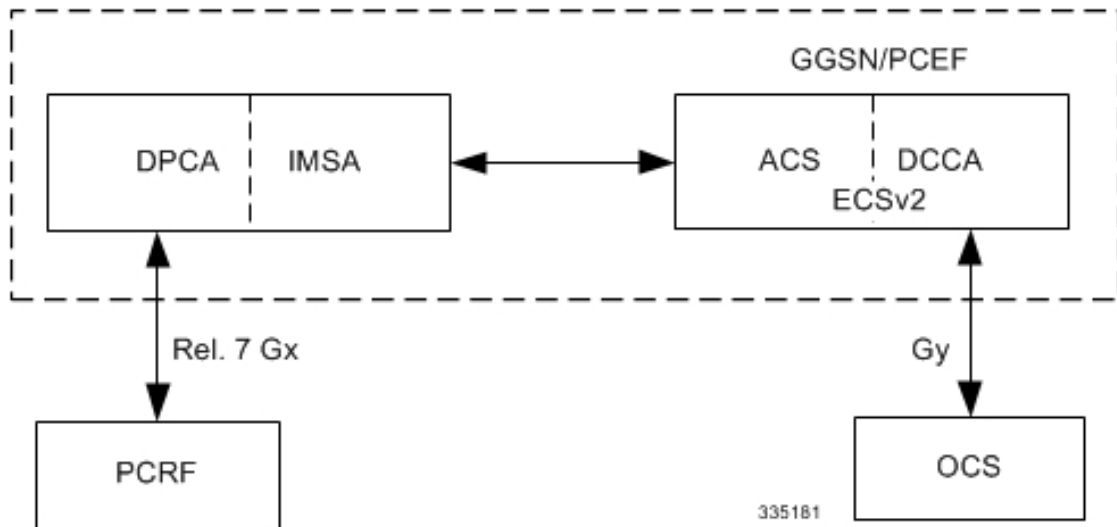

Supported Networks and Platforms

This feature is supported on all chassis with StarOS Release 8.1 and later running GGSN service for the core network services.

License Requirements

The Rel. 7 Gx interface support is a licensed Cisco feature. A separate feature license may be required. Contact your Cisco account representative for detailed information on specific licensing requirements. For information on installing and verifying licenses, refer to the *Managing License Keys* section of the *Software Management Operations* chapter in the *System Administration Guide*.

Supported Standards

The Rel 7. Gx interface support is based on the following standards and RFCs:

- 3GPP TS 23.203 V7.6.0 (2008-03): 3rd Generation Partnership Project; Technical Specification Group Services and System Aspects; Policy and charging control architecture (Release 7)
- 3GPP TS 29.212 V7.8.0 (2009-03): 3rd Generation Partnership Project; Technical Specification Group Core Network and Terminals; Policy and Charging Control over Gx reference point (Release 7)
- 3GPP TS 29.213 V7.4.0 (2008-03): 3rd Generation Partnership Project; Technical Specification Group Core Network and Terminals; Policy and Charging Control signalling flows and QoS parameter mapping; (Release 7)
- RFC 3588, Diameter Base Protocol; September 2003
- RFC 4006, Diameter Credit-Control Application; August 2005

Terminology and Definitions

This section describes features and terminology pertaining to Rel. 7 Gx functionality.

Policy Control

The process whereby the PCRF indicates to the PCEF how to control the IP-CAN bearer.

Policy control comprises the following functions:

- **Binding:** Binding is the generation of an association between a Service Data Flow (SDF) and the IP CAN bearer (for GPRS a PDP context) transporting that SDF.

The QoS demand in the PCC rule, as well as the SDF template are input for the bearer binding. The selected bearer will have the same QoS Class as the one indicated by the PCC rule.

Depending on the type of IP-CAN and bearer control mode, bearer binding can be executed either by the PCRF, or both PCRF and PCEF.

- For UE-only IP-CAN bearer establishment mode, the PCRF performs bearer binding. When the PCRF performs bearer binding, it indicates the bearer (PDP context) by means of Bearer ID. The Bearer ID uniquely identifies the bearer within the PDP session.
- For UE/NW IP-CAN bearer establishment mode, the PCRF performs the binding of the PCC rules for user controlled services, while the PCEF performs the binding of the PCC rules for the network-controlled services.

Prior to Release 16.0, the rule binding was getting rejected. In 16.0 and later releases, the binding of PCEF rules will be successful when BCM mode is set to UE-only for EPS IP-CAN bearer without "bearer-ID" in the PCRF messages such as RAR or CCA-U.

In the 3G to 4G handover scenario, rule binding and rule removal will be successful in UE-only mode and any filter (and related info) changes because of this modification/installation/removal will not be notified to UE as updates in UE only mode cannot be sent to UE. These rules are only considered for charging and the expectation is that the same rules are again modified in 4G (if handover is done) so that the filters (and related info) can be notified to UE.

In releases prior to 18, P-GW/GGSN does not send CCR-U with Charging Rule report for rule binding failure occurred during 4G to 3G HO in a collision case where create/update bearer response in 3G/4G is pending and update bearer of 3G HO is received. In 18 and later releases, CCR-U is generated and sent to PCRF for reporting rule failure when the collision happens during GnGp HO scenario.

This additional Gx message (CCR-U) triggered will require multiple CCR-U's to be configured when RAT_TYPE trigger is enabled. Otherwise, the subscriber call will be dropped whenever the collision happens during HO.

- **Gating Control:** Gating control is the blocking or allowing of packets, belonging to an SDF, to pass through to the desired endpoint. A gate is described within a PCC rule and gating control is applied on a per SDF basis. The commands to open or close the gate leads to the enabling or disabling of the passage for corresponding IP packets. If the gate is closed, all packets of the related IP flows are dropped. If the gate is opened, the packets of the related IP flows are allowed to be forwarded.
- **Event Reporting:** Event reporting is the notification of and reaction to application events to trigger new behavior in the user plane as well as the reporting of events related to the resources in the Gateway (PCEF).
 - Event triggers may be used to determine which IP-CAN session modification or specific event causes the PCEF to re-request PCC rules. Although event trigger reporting from PCEF to PCRF can apply for an IP CAN session or bearer depending on the particular event, provisioning of event triggers will be done at session level.

Note that in 11.0 and later releases, RAR with unknown event triggers are silently ignored and responded with `DIAMETER_SUCCESS`. In earlier releases, when unknown event triggers were received in the RAR command from PCRF, invalid AVP result code was set in the RAA command.

- The Event Reporting Function (ERF) receives event triggers from PCRF during the Provision of PCC Rules procedure and performs event trigger detection. When an event matching the received event trigger occurs, the ERF reports the occurred event to the PCRF. If the provided event triggers are associated with certain parameter values then the ERF includes those values in the response back to the PCRF. The Event Reporting Function is located in the PCEF.

In StarOS releases prior to 14.0, `SUCCESSFUL_RESOURCE_ALLOCATION (22)` event trigger was sent for rules irrespective of successful installation. In 14.0 and later releases, `SUCCESSFUL_RESOURCE_ALLOCATION (22)` event trigger will be sent under the following conditions:

- When a rule is installed successfully (and the event trigger is armed by PCRF and resource-allocation-notification is enabled).
- On partial failure, i.e., when two or more rules are installed and at least one of the rules were successfully installed. (and the event trigger is armed by PCRF and resource-allocation-notification is enabled).

On complete failure, i.e., none of the rules were installed, the event-trigger `SUCCESSFUL_RESOURCE_ALLOCATION (22)` will not be sent.



Important In this release, event triggers "IP-CAN_CHANGE" and "MAX_NR_BEARERS_REACHED" are not supported.

- **QoS Control:** QoS control is the authorization and enforcement of the maximum QoS that is authorized for a SDF or an IP-CAN bearer or a QoS Class Identifier (QCI). In case of an aggregation of multiple SDFs (for GPRS a PDP context), the combination of the authorized QoS information of the individual SDFs is provided as the authorized QoS for this aggregate.
 - QoS control per SDF allows the PCC architecture to provide the PCEF with the authorized QoS to be enforced for each specific SDF.
 - The enforcement of the authorized QoS of the IP-CAN bearer may lead to a downgrading or upgrading of the requested bearer QoS by the Gateway (PCEF) as part of a UE-initiated IP-CAN bearer establishment or modification. Alternatively, the enforcement of the authorized QoS may, depending on operator policy and network capabilities, lead to network-initiated IP-CAN bearer establishment or modification. If the PCRF provides authorized QoS for both, the IP-CAN bearer and PCC rule(s), the enforcement of authorized QoS of the individual PCC rules takes place first.
 - QoS authorization information may be dynamically provisioned by the PCRF, or it can be a predefined PCC rule in the PCEF. In case the PCRF provides PCC rules dynamically, authorized QoS information for the IP-CAN bearer (combined QoS) may be provided. For a predefined PCC rule within the PCEF, the authorized QoS information takes affect when the PCC rule is activated. The PCEF combines the different sets of authorized QoS information, that is the information received from the PCRF and the information corresponding to the predefined PCC rules. The PCRF knows the authorized QoS information of the predefined PCC rules and takes this information into account when activating them. This ensures that the combined authorized QoS of a set of PCC rules that are

activated by the PCRF is within the limitations given by the subscription and operator policies regardless of whether these PCC rules are dynamically provided, predefined, or both.



Important In this release, QoS Resource Reservation is not supported.

Supported Features:

- Provisioning and Policy Enforcement of Authorized QoS: The PCRF may provide authorized QoS to the PCEF. The authorized QoS provides appropriate values for resources to be enforced.
- Provisioning of "Authorized QoS" Per IP CAN Bearer: The authorized QoS per IP-CAN bearer is used if the bearer binding is performed by the PCRF.
- Policy Enforcement for "Authorized QoS" per IP CAN Bearer: The PCEF is responsible for enforcing the policy-based authorization, that is to ensure that the requested QoS is in-line with the "Authorized QoS" per IP CAN Bearer.
- Policy Provisioning for Authorized QoS Per SDF: The provisioning of authorized QoS per SDF is a part of PCC rule provisioning procedure.
 - Policy Enforcement for Authorized QoS Per SDF: If an authorized QoS is defined for a PCC rule, the PCEF limits the data rate of the SDF corresponding to that PCC rule not to exceed the maximum authorized bandwidth for the PCC rule by discarding packets exceeding the limit.
 - Upon deactivation or removal of a PCC rule, the PCEF frees the resources reserved for that PCC rule. If the PCRF provides authorized QoS for both the IP-CAN bearer and PCC rule(s), the enforcement of authorized QoS of the individual PCC rules takes place first.



Important In this release, coordination of authorized QoS scopes in mixed mode (BCM = UE_NW) is not supported.

- Provisioning of Authorized QoS Per QCI: If the PCEF performs the bearer binding, the PCRF may provision an authorized QoS per QCI for non-GBR bearer QCI values. If the PCRF performs the bearer binding the PCRF does not provision an authorized QoS per QCI. The PCRF does not provision an authorized QoS per QCI for GBR bearer QCI values.



Important Only standards-based QCI values of 1 through 9 are supported. QCI values 1 through 9 are defined in 3GPP Specification TS 23.203 "Policy and charging control architecture".

- Policy Enforcement for Authorized QoS per QCI: The PCEF can receive an authorized QoS per QCI for non GBR-bearer QCI values.
- Other Features:
 - Bearer Control Mode Selection: The PCEF may indicate, via the Gx reference point, a request for Bearer Control Mode (BCM) selection at IP-CAN session establishment or IP-CAN session

modification (as a consequence of an SGSN change). It will be done using the "PCC Rule Request" procedure.

If the Bearer-Control-Mode AVP is not received from PCRF, the IP-CAN session is not terminated. The value negotiated between UE/SGSN/GGSN is considered as the BCM. The following values are considered for each of the service types:

- GGSN: The negotiated value between UE/SGSN/GGSN is considered.

In the following scenarios UE_ONLY is chosen as the BCM:

Scenario 1:

- UE-> UE_ONLY
- SGSN-> UE_ONLY
- GGSN-> UE_ONLY
- PCRF-> NO BCM

Scenario 2:

- UE-> UE_ONLY
- SGSN-> UE_ONLY
- GGSN-> Mixed
- PCRF-> NO BCM

- GTP-PGW: BCM of UE_NW is considered.
- IPSG: BCM of UE_ONLY is considered.
- HSGW/SGW/PDIF/FA/PDSN/HA/MIPv6HA: BCM of NONE is considered.
- PCC Rule Error Handling: If the installation/activation of one or more PCC rules fails, the PCEF includes one or more Charging-Rule-Report AVP(s) in either a CCR or an RAA command for the affected PCC rules. Within each Charging-Rule-Report AVP, the PCEF identifies the failed PCC rule(s) by including the Charging-Rule-Name AVP(s) or Charging-Rule-Base-Name AVP(s), identifies the failed reason code by including a Rule-Failure-Code AVP, and includes the PCC-Rule-Status AVP.

If the installation/activation of one or more new PCC rules (that is, rules that were not previously successfully installed) fails, the PCEF sets the PCC-Rule-Status to INACTIVE for both the PUSH and the PULL modes.

If a PCC rule was successfully installed/activated, but can no longer be enforced by the PCEF, the PCEF sends the PCRF a new CCR command and include a Charging-Rule-Report AVP. The PCEF includes the Rule-Failure-Code AVP within the Charging-Rule-Report AVP and sets the PCC-Rule-Status to INACTIVE.

In releases prior to 18, P-GW/GGSN does not send CCR-U with Charging Rule report for rule binding failure occurred during 4G to 3G HO in a collision case where create/update bearer response in 3G/4G is pending and update bearer of 3G HO is received. In 18 and later releases, CCR-U is generated and sent to PCRF for reporting rule failure when the collision happens during GnGp HO scenario.

This additional Gx message (CCR-U) triggered will require multiple CCR-U's to be configured when RAT_TYPE trigger is enabled. Otherwise, the subscriber call will be dropped whenever the collision happens during HO.

- Time of the Day Procedures: PCEF performs PCC rule request as instructed by the PCRF. Revalidation-Time when set by the PCRF, causes the PCEF to trigger a PCRF interaction to request PCC rules from the PCRF for an established IP CAN session. The PCEF stops the timer once the PCEF triggers a REVALIDATION_TIMEOUT event.



Important

In 11.0 and later releases, Rule-Activation-Time / Rule-Deactivation-Time / Revalidation-Time AVP is successfully parsed only if its value corresponds to current time or a later time than the current IPSG time, else the AVP and entire message is rejected. In earlier releases the AVP is successfully parsed only if its value corresponds to a later time than the current IPSG time, else the AVP and entire message is rejected.

In releases prior to 17.0, if "Rule-Deactivation-Time" AVP for a predefined rule was omitted in a CCA-U or RAR message, then any previous value for this AVP was continued to be used in the chassis. In 17.0 and later releases, if Rule-Deactivation-Time AVP is omitted in CCA/RAR, then any previous value for this AVP is no longer valid. The new behavior is compliant to the 3GPP specification for Gx, version 12.1.0.

If PCRF enables the same predefined rule again in RAR/CCA-U without Rule-Deactivation-Time AVP, then the deactivation-time for this rule, if any, will be removed.

For switching to the old behavior, PCRF should re-send the same value of Rule-Deactivation-Time AVP along with predef-rule name in the PCRF message (RAR, CCA-U).



Important

This behavior change is applicable only to predefined rules.

Support for Firewall Policy on Gx: The Diameter AVP "SN-Firewall-Policy" has been added to the Diameter dynamic dictionary to support Firewall policy on Gx interface. This AVP can be encoded in CCA-I message to apply/overwrite the fw-and-nat policy that has either been statically assigned to the PDP context via APN configuration or dynamically assigned via RADIUS in Access-Accept. This AVP can also be parsed in any CCA-U or RAR message to modify the fw-and-nat policy that is currently assigned to the PDP context.

Charging Control

Charging Control is the process of associating packets belonging to a SDF to a charging key, and applying online charging and/or offline charging, as appropriate. Flow-based charging handles differentiated charging of the bearer usage based on real time analysis of the SDFs. In order to allow for charging control, the information in the PCC rule identifies the SDF and specifies the parameters for charging control. The PCC rule information may depend on subscription data.

In the case of online charging, it is possible to apply an online charging action upon PCEF events (for example, re-authorization upon QoS change).

It is possible to indicate to the PCEF that interactions with the charging systems are not required for a PCC rule, that is to perform neither accounting nor credit control for this SDF, and then no offline charging information is generated.

Supported Features:

- Provisioning of Charging-related Information for the IP-CAN Session.
- Provisioning of Charging Addresses: Primary or secondary event charging function name (Online Charging Server (OCS) addresses or the peer names).



Important In this release, provisioning of primary or secondary charging collection function name (Offline Charging Server (OFCS) addresses) over Gx is not supported.

- Provisioning of Default Charging Method: In this release, the default charging method is sent in CCR-I message. For this, new AVPs Online/Offline are sent in CCR-I message based on the configuration. The Online/Offline AVP received at command level applies only to dynamic rules if they are not configured at PCC rule level.

Charging Correlation

For the purpose of charging correlation between SDF level and application level (for example, IMS) as well as on-line charging support at the application level, applicable charging identifiers and IP-CAN type identifiers are passed from the PCRF to the AF, if such identifiers are available.

For IMS bearer charging, the IP Multimedia Core Network (IM CN) subsystem and the Packet Switched (PS) domain entities are required to generate correlated charging data.

In order to achieve this, the Gateway provides the GGSN Charging Identifier (GCID) associated with the PDP context along with its address to the PCRF. The PCRF in turn sends the IMS Charging Identifier (ICID), which is provided by the P-CSCF, to the Gateway. The Gateway generates the charging records including the GCID as well as the ICID if received from PCRF, so that the correlation of charging data can be done with the billing system.

PCRF also provides the flow identifier, which uniquely identifies an IP flow in an IMS session.

Policy and Charging Control (PCC) Rules

A PCC rule enables the detection of an SDF and provides parameters for policy control and/or charging control. The purpose of the PCC rule is to:

- Detect a packet belonging to an SDF.
 - Select downlink IP CAN bearers based on SDF filters in the PCC rule.
 - Enforce uplink IP flows are transported in the correct IP CAN bearer using the SDF filters within the PCC rule.
- Identify the service that the SDF contributes to.
- Provide applicable charging parameters for an SDF.
- Provide policy control for an SDF.

The PCEF selects a PCC rule for each packet received by evaluating received packets against SDF filters of PCC rules in the order of precedence of the PCC rules. When a packet matches a SDF filter, the packet matching process for that packet is completed, and the PCC rule for that filter is applied.

There are two types of PCC rules:

- **Dynamic PCC Rules:** Rules dynamically provisioned by the PCRF to the PCEF via the Gx interface. These PCC rules may be either predefined or dynamically generated in the PCRF. Dynamic PCC rules can be installed, modified, and removed at any time.
- **Predefined PCC Rule:** Rules preconfigured in the PCEF by the operators. Predefined PCC rules can be activated or deactivated by the PCRF at any time. Predefined PCC rules within the PCEF may be grouped allowing the PCRF to dynamically activate a set of PCC rules over the Gx reference point.



Important

A third type of rule, the static PCC rule can be preconfigured in the chassis by the operators. Static PCC rules are not explicitly known in the PCRF, and are not under control of the PCRF. Static PCC rules are bound to general purpose bearer with no Gx control.

A PCC rule consists of:

- **Rule Name:** The rule name is used to reference a PCC rule in the communication between the PCEF and PCRF.
- **Service Identifier:** The service identifier is used to identify the service or the service component the SDF relates to.
- **Service Data Flow Filter(s):** The service flow filter(s) is used to select the traffic for which the rule applies.
- **Precedence:** For different PCC rules with overlapping SDF filter, the precedence of the rule determines which of these rules is applicable. When a dynamic PCC rule and a predefined PCC rule have the same priority, the dynamic PCC rule takes precedence.
- **Gate Status:** The gate status indicates whether the SDF, detected by the SDF filter(s), may pass (gate is open) or will be discarded (gate is closed) in uplink and/or in downlink direction.
- **QoS Parameters:** The QoS information includes the QoS class identifier (authorized QoS class for the SDF), the Allocation and Retention Priority (ARP), and authorized bitrates for uplink and downlink.



Important

In earlier releases, ECS used only the Priority-Level part of ARP byte for bearer binding, (along with QCI). Now the entire ARP byte is used for bearer binding (along with QCI). Since the capability and vulnerability bits are optional in a dynamic rule, if a dynamic rule is received without these flags, it is assumed that the capability bit is set to 1 (disabled) and vulnerability bit is set to 0 (enabled). For predefined rules, currently configuring these two flags is not supported, so as of now all predefined rules are assumed to have capability bit set to 1 (disabled) and vulnerability bit set to 0 (enabled).

- **Charging key (rating group)**
- **Other charging parameters:** The charging parameters define whether online and offline charging interfaces are used, what is to be metered in offline charging, on what level the PCEF will report the usage related to the rule, and so on.



Important In this release, configuring the Metering Method and Reporting Level for dynamic PCC rules is not supported.

PCC rules also include Application Function (AF) record information for enabling charging correlation between the application and bearer layer if the AF has provided this information via the Rx interface. For IMS, this includes the IMS Charging Identifier (ICID) and flow identifiers.



Important ASR 5500 supports only eight flow information including the flow description per dynamic charging rule in a Gx message.

In releases prior to 14.0, there were only 10 PCC rules that were recovered per bearer in the event of a session manager crash. In 14.0 and later releases, this limit has been increased to 24. That is, up to 24 PCC rules can be recovered post ICSR.

With the increase in the limit of PCC rules that can be recovered, the rules are not lost and hence the charging applied to the end users are not impacted.

In releases prior to 17.0, when P-GW received PCC rules from PCRF and it results in Create Bearer or Update Bearer to be triggered towards MME/S-GW, the PCC rules were kept in a pending-active state. Any modification request that was received for these pending-active rules were not currently honored by the P-GW. In 17.0 and later releases, when modification for the PCC rules in pending-active state is received, the modified parameters will be buffered at P-GW. After the response for the pending request is received from the access network, P-GW will process the modification of the buffered parameters and if required generate another update towards network.

PCC Procedures over Gx Reference Point

Request for PCC Rules

The PCEF, via the Gx reference point, requests for PCC rules in the following instances:

- At IP-CAN session establishment
- At IP-CAN session modification

PCC rules can also be requested as a consequence of a failure in the PCC rule installation/activation or enforcement without requiring an event trigger.

Provisioning of PCC Rules

The PCRF indicates, via the Rel. 8 Gx reference point, the PCC rules to be applied at the PCEF. This may be using one of the following procedures:

- PULL (provisioning solicited by the PCEF): In response to a request for PCC rules being made by the PCEF, the PCRF provisions PCC rules in the CC-Answer.
- PUSH (unsolicited provisioning): The PCRF may decide to provision PCC rules without obtaining a request from the PCEF. For example, in response to information provided to the PCRF via the Rx reference point, or in response to an internal trigger within the PCRF. To provision PCC rules without a request from the PCEF, the PCRF includes these PCC rules in an RA-Request message. No CCR/CCA messages are triggered by this RA-Request.

For each request from the PCEF or upon unsolicited provisioning, the PCRF provisions zero or more PCC rules. The PCRF may perform an operation on a single PCC rule by one of the following means:

- To activate or deactivate a PCC rule that is predefined at the PCEF, the PCRF provisions a reference to this PCC rule within a Charging-Rule-Name AVP and indicates the required action by choosing either the Charging-Rule-Install AVP or the Charging-Rule-Remove AVP.
- To install or modify a PCRF-provisioned PCC rule, the PCRF provisions a corresponding Charging-Rule-Definition AVP within a Charging-Rule-Install AVP.
- To remove a PCC rule which has previously been provisioned by the PCRF, the PCRF provisions the name of this rule as value of a Charging-Rule-Name AVP within a Charging-Rule-Remove AVP.



Important

In 11.0 and later releases, the maximum valid length for a charging rule name is 63 bytes. When the length of the charging rule name is greater than 63 bytes, a charging rule report with RESOURCES_LIMITATION as Rule-Failure-Code is sent. This charging rule report is sent only when the length of the rule name is lesser than 128 characters. When the charging rule name length is greater than or equal to 128 characters no charging rule report will be sent. In earlier releases, the length of the charging rule name constructed by PCRF was limited to 32 bytes.

Releases prior to 14.0, when PCRF has subscribed to Out of Credit trigger, on session connect when one rule validation fails and also when an Out of Credit was received from OCS for another rule, P-GW was trying to report these failures in different CCR-U to PCRF. However, the second CCR-U of Out of credit was getting dropped internally.

In 14.0 and later releases, on session connect, P-GW combines the rule failure and out of credit in the same CCR-U and sends to PCRF.

Selecting a PCC Rule for Uplink IP Packets

If PCC is enabled, the PCEF selects the applicable PCC rule for each received uplink IP packet within an IP CAN bearer by evaluating the packet against uplink SDF filters of PCRF-provided or predefined active PCC rules of this IP CAN bearer in the order of the precedence of the PCC rules.



Important

When a PCRF-provided PCC rule and a predefined PCC rule have the same precedence, the uplink SDF filters of the PCRF-provided PCC rule is applied first.



Important

In 11.0 and later releases, IMSA and ECS allow the PCRF to install two (or more) dynamic rules with the same precedence value. In earlier releases, for two distinct dynamic rules having the same precedence the second rule used to be rejected.

When a packet matches an SDF filter, the packet matching process for that packet is completed, and the PCC rule for that filter is applied. Uplink IP packets which do not match any PCC rule of the corresponding IP CAN bearer are discarded.

Selecting a PCC Rule and IP CAN Bearer for Downlink IP Packets

If PCC is enabled, the PCEF selects a PCC rule for each received downlink IP packet within an IP CAN session by evaluating the packet against downlink SDF filters of PCRF-provided or predefined active PCC rules of all IP CAN bearers of the IP CAN session in the order of the precedence of the PCC rules.



Important

When a PCRF-provided PCC rule and a predefined PCC rule have the same precedence, the downlink SDF filters of the PCRF-provided PCC rule are applied first.

When a packet matches a SDF filter, the packet matching process for that packet is completed, and the PCC rule for that filter is applied. The Downlink IP Packet is transported within the IP CAN bearer where the selected PCC rule is mapped. Downlink IP packets that do not match any PCC rule of the IP CAN session are discarded.

The following procedures are also supported:

- Indication of IP-CAN Bearer Termination Implications
- Indication of IP-CAN Session Termination: When the IP-CAN session is being terminated (for example, for GPRS when the last PDP Context within the IP-CAN session is being terminated) the PCEF contacts the PCRF.
- Request of IP-CAN Bearer Termination: If the termination of the last IP CAN bearer within an IP CAN session is requested, the PCRF and PCEF apply the "Request of IP-CAN Session Termination" procedure.
- Request of IP-CAN Session Termination: If the PCRF decides to terminate an IP CAN session due to an internal trigger or trigger from the SPR, the PCRF informs the PCEF. The PCEF acknowledges to the PCRF and instantly removes/deactivates all the PCC rules that have been previously installed or activated on that IP-CAN session.

The PCEF applies IP CAN specific procedures to terminate the IP CAN session. For GPRS, the GGSN send a PDP context deactivation request with the teardown indicator set to indicate that the termination of the entire IP-CAN session is requested. Furthermore, the PCEF applies the "Indication of IP CAN Session Termination" procedure.

In 12.0 and later releases, volume or rule information obtained from PCRF is discarded if the subscriber is going down.

Volume Reporting Over Gx

This section describes the 3GPP Rel. 9 Volume Reporting over Gx feature, which is supported by all products supporting Rel. 7 Gx interface.

License Requirements

The Volume Reporting over Gx is a licensed Cisco feature. A separate feature license may be required. Contact your Cisco account representative for detailed information on specific licensing requirements. For information on installing and verifying licenses, refer to the *Managing License Keys* section of the *Software Management Operations* chapter in the *System Administration Guide*.



Important

In 12.0 and later releases, no separate license is required for Charging over Gx / Volume Reporting over Gx feature. This feature can be enabled as part of "Policy Interface" license.

Supported Standards

The Volume Reporting over Gx feature is based on the following standard:

3GPP TS 29.212 V9.5.0 (2010-06): 3rd Generation Partnership Project; Technical Specification Group Core Network and Terminals; Policy and Charging Control over Gx reference point (Release 9).

Feature Overview

The Volume Reporting over Gx feature provides PCRF the capability to make real-time decisions based on the data usage by subscribers.



Important

Volume Reporting over Gx is applicable only for volume quota.

In release 10.0, only total data usage reporting is supported, uplink/downlink level reporting is not supported. In 10.2 and later releases, it is supported.

The PCEF only reports the accumulated usage since the last report for usage monitoring and not from the beginning.

If the usage threshold is set to zero (infinite threshold), no further threshold events will be generated by PCEF, but monitoring of usage will continue and be reported at the end of the session.

In 12.2 and later releases, usage reporting on bearer termination is supported.

The following steps explain how Volume Reporting over Gx works:

1. PCEF after receiving the message from PCRF parses the usage monitoring related AVPs, and sends the information to IMSA.
2. IMSA updates the information to ECS.
3. Once the ECS is updated with the usage monitoring information from PCRF, the PCEF (ECS) starts tracking the data usage.
4. For session-level monitoring, the ECS maintains the amount of data usage.
5. For PCC rule monitoring, usage is monitored with the monitoring key as the unique identifier. Each node maintains the usage information per monitoring key. When the data traffic is passed, the usage is checked against the usage threshold values and reported as described in the *Usage Reporting* section.
6. The PCEF continues to track data usage after the threshold is reached and before a new threshold is provided by the PCRF. If a new usage threshold is not provided by the PCRF in the acknowledgement of an IP-CAN Session modification where its usage was reported, then usage monitoring does not continue in the PCEF for that IP CAN session.

Usage Monitoring

- Usage Monitoring at Session Level: PCRF subscribes to the session-level volume reporting over Gx by sending the Usage-Monitoring-Information AVP with the usage threshold level set in Granted-Service-Unit AVP and Usage-Monitoring-Level AVP set to SESSION_LEVEL(0). After the AVPs are parsed by DPCA, IMSA updates the information to ECS. Once ECS is updated usage monitoring is started and constantly checked with the usage threshold whenever the data traffic is present. In 11.0 and later releases, Monitoring Key at session level is supported.

In 12.0 and later releases, enabling and disabling session usage in a single message from PCRF is supported. This is supported only if the monitoring key is associated at session level.

In 12.0 and later releases, monitoring of usage based on input/output octet threshold levels is supported. Usage is reported based on the enabled threshold level. If multiple levels are enabled, usage will be reported on all the enabled levels even if only one of the levels is breached. Monitoring will be stopped on the missing threshold levels in the response for the usage report from PCRF (expected to provide the complete set again if PCRF wants to continue monitoring on the multiple levels enabled earlier).

Total threshold level along with UL/DL threshold level in the GSU AVP is treated as an error and only total threshold level is accepted.

In releases prior to 17.0, extra CCR-U was generated for a monitoring key when the following requests are received in the response to the CCR-U which reported the usage for the same monitoring key.

- immediate reporting request with monitoring key at rule level
- immediate reporting request with or without monitoring key at session level
- explicit disable request at rule level
- explicit disable request at session level

In 17.0 and later releases, extra CCR-U is not generated for a monitoring key when all the above mentioned requests are received in the response to the CCR-U which reported the usage for the same monitoring key. Also, extra CCR-U is not generated when immediate reporting request without monitoring key at rule level is received in the response to the CCR-U which reported the usage for all the active monitoring keys.

- **Usage Monitoring at Flow Level:** PCRF subscribes to the flow-level volume reporting over Gx by sending the Usage-Monitoring-Information AVP with the usage threshold level set in Granted-Service-Unit AVP and Usage-Monitoring-Level AVP set to PCC_RULE_LEVEL(1). Monitoring Key is mandatory in case of a flow-level monitoring since the rules are associated with the monitoring key and enabling/disabling of usage monitoring at flow level can be controlled by PCRF using it. After the AVPs are parsed by DPCA, IMSA updates the information to ECS. Once ECS is updated usage monitoring is started and constantly checked with the usage threshold whenever the data traffic is present.

Usage monitoring is supported for static, predefined rules, and dynamic rule definitions.

- **Usage Monitoring for Static Rules:** In the case of static rules, the usage reporting on last rule removal associated with the monitoring key is not applicable. In this case only the usage monitoring information is received from the PCRF.
- **Usage Monitoring for Predefined Rules:** If the usage monitoring needs to be enabled for the predefined rules, PCRF sends the rule and the usage monitoring information containing the monitoring key and the usage threshold. The Monitoring key should be the same as the one pre-configured in PCEF for that predefined rule. There can be multiple rules associated with the same monitoring key. Hence enabling a particular monitoring key would result in the data being tracked for multiple rules having the same monitoring key. After DPCA parses the AVPs IMSA updates the information to ECS. Once ECS is updated usage monitoring is started and constantly checked with the usage threshold whenever the data traffic is present.
- **Usage Monitoring for Dynamic Rules:** If the usage monitoring needs to be enabled for dynamic ruledefs, PCRF provides the monitoring key along with a charging rule definition and the usage monitoring information containing the monitoring key and the usage threshold. This would result in the usage monitoring being done for all the rules associated with that monitoring key. After DPCA parses the AVPs, IMSA updates the information to ECS. Once ECS is updated, the usage monitoring is started and constantly checked with the usage threshold whenever the data traffic is present.

Monitoring key for dynamic ruledef is dynamically assigned by PCRF which is the only difference with predefined rules in case of usage monitoring.

In releases prior to 15.0, when threshold breach happens for multiple monitoring keys at the same time, only one of the monitoring keys' usage is reported and the rest of the monitoring keys' usage is reported in CCR-T (threshold set to infinity). On Tx expiry/TCP link error, unreported usage is stored at ECS and reported only on session termination.

In 15.0 and later releases, only one of the monitoring keys' usage is reported first. Upon receiving successful response from PCRF, the rest of the monitoring keys' usage is reported to PCRF. On Tx expiry/TCP link error, unreported usage is stored at ECS. Any future successful interaction with PCRF for the session will send unreported UMI to PCRF.

Usage Reporting

Usage at subscriber/flow level is reported to PCRF under the following conditions:

- **Usage Threshold Reached:** PCEF records the subscriber data usage and checks if the usage threshold provided by PCRF is reached. This is done for both session and rule level reporting.

For session-level reporting, the actual usage volume is compared with the usage volume threshold.

For rule-level reporting the rule that hits the data traffic is used to find out if the monitoring key is associated with it, and based on the monitoring key the data usage is checked. Once the condition is met, it reports the usage information to IMSA and continues monitoring. IMSA then triggers the CCR-U if "USAGE_REPORT" trigger is enabled by the PCRF. The Usage-Monitoring-Information AVP is sent in this CCR with the "Used-Service-Unit" set to the amount of data usage by subscriber.

If PCRF does not provide a new usage threshold in the usage monitoring information as a result of CCR from PCEF when the usage threshold is reached, the usage monitoring is stopped at PCEF and no usage status is reported.

In the non-standard Volume Reporting over Gx implementation, usage monitoring will be stopped once the threshold is breached, else the monitoring will continue. There will be no further usage reporting until the CCA is received.

- **Usage Monitoring Disabled:** If the PCRF explicitly disables the usage monitoring with Usage-Monitoring-Support AVP set to USAGE_MONITORING_DISABLED, the PCEF stops monitoring and reports the usage information (when the monitoring was enabled) to PCRF if the usage monitoring is disabled by PCRF as a result of CCR from PCEF which is not related to reporting usage, other external triggers, or a PCRF internal trigger. If the PCRF does not provide a new usage threshold as a result of CCR from PCEF when the usage threshold is reached, the usage monitoring is stopped at PCEF and no further usage status is reported.

- **IP CAN Session Termination:** When the IP CAN session is terminated, the accumulated subscriber usage information is reported to PCRF in the CCR-T from PCEF. If PCC usage level information is enabled by PCRF, the PCC usage will also be reported.

PCRF uses RAR message and includes Session-Release-Cause AVP in it to initiate IP CAN Session Termination. However, there are some scenarios where PCRF may want to terminate the IP CAN Session in CCA messages. In order to avoid an unnecessary additional message, PCRF can inform P-GW to terminate the subscriber in CCA-U message itself. Hence, in 17.0 and later releases, the Session Release Cause has been added in CCA messages for all Gx dictionaries.

- **PCC Rule Removal:** When the PCRF deactivates the last PCC rule associated with a usage monitoring key, the PCEF sends a CCR with the data usage for that monitoring key. If the PCEF reports the last

PCC rule associated with a usage monitoring key is inactive, the PCEF reports the accumulated usage for that monitoring key within the same CCR command if the Charging-Rule-Report AVP was included in a CCR command; otherwise, if the Charging-Rule-Report AVP was included in an RAA command, the PCEF sends a new CCR command to report accumulated usage for the usage monitoring key. In 12.0 and later releases, usage reporting on last rule deactivation using rule deactivation time set by PCRF is supported.

Releases prior to 14.0, when PCC rule was tried to be removed while waiting for access side update bearer response, the charging rules were not removed. In 14.0 and later releases, on receiving message from PCRF, the rule that is meant for removal is marked and then after the access side procedure is complete the rule is removed.

- **PCRF Requested Usage Report:** In 10.2 and later releases, the accumulated usage since the last report is sent even in case of immediate reporting, the usage is reset after immediate reporting and usage monitoring continued so that the subsequent usage report will have the usage since the current report. In earlier releases the behavior was to accumulate the so far usage in the next report.
- **Release 12.2 onwards,** usage reporting on bearer termination can be added. When a bearer is deleted due to some reason, the rules associated with the bearer will also be removed. So, the usage will be reported on the monitoring key(s) whose associated rule is the last one that is removed because of bearer termination.
- **Revalidation Timeout:** In the non-standard implementation, if usage monitoring and reporting is enabled and a revalidation timeout occurs, the PCEF sends a CCR to request PCC rules and reports all accumulated usage for all enabled monitoring keys since the last report (or since usage reporting was enabled if the usage was not yet reported) with the accumulated usage at IP-CAN session level (if enabled) and at service data flow level (if enabled) This is the default behavior.

In the case of standard implementation, this must be enabled by CLI configuration.



Important

The Usage Reporting on Revalidation Timeout feature is available by default in non-standard implementation of Volume Reporting over Gx. In 10.2 and later releases, this is configurable in the standard implementation. This is not supported in 10.0 release for standard based volume reporting.

Once the usage is reported, the usage counter is reset to zero. The PCEF continues to track data usage from the zero value after the threshold is reached and before a new threshold is provided by the PCRF. If a new usage threshold is not provided by the PCRF in the acknowledgement of an IP-CAN Session modification where its usage was reported, then usage monitoring does not continue in the PCEF for that IP CAN session and the usage accumulated between the CCR-CCA will be discarded.

In releases prior to 17.0, CCR-U triggered on server retries does not take server granted quota into account for reporting USU. In 17.0 and later releases, CCR-U triggered on server retries takes server granted quota into account for reporting USU. For newly created MSCC, interim quota configuration is taken as reference for reporting USU.

For information on how to configure the Volume Reporting over Gx feature, see [Configuring Volume Reporting over Gx, on page 233](#).

ICSR Support for Volume Reporting over Gx (VoRoGx)

In releases prior to 15.0, post the ICSR switchover, any existing session for which the PCRF has enabled volume reporting used to continue indefinitely until the session is terminated or until CCR-U is sent for a given trigger, without having the volume counted via Gx.

To summarize, after an ICSR switchover, volume reporting over Gx is no longer done for existing sessions. Also, volume usage is not synced to standby chassis.

In 15.0 and later releases, volume threshold and volume usage are synced to standby chassis to support volume reporting over Gx for existing sessions post switchover.

Without this support it cannot cause a subscriber to use higher speeds than what s/he is supposed to get, if volume reporting is for example used to enforce fair usage; the operator may already consider this a revenue loss. It will also severely impact roaming subscribers who are supposed to get a notification and be blocked/redirected once the limits set by the EU roaming regulation are reached. If a session continues now without being blocked, the operator is not allowed to charge for data beyond the limit and will have a significant and real revenue loss (roaming partner may still charge for the data used on their SGSNs).

How Rel. 7 Gx Works

This section describes how dynamic policy and charging control for subscribers works with Rel. 7 Gx interface support in GPRS/UMTS networks.

The following figure and table explain the IMSA process between a system and IMS components that is initiated by the UE.

In this example, the Diameter Policy Control Application (DPCA) is the Gx interface to the PCRF. The interface between IMSA with PCRF is the Gx interface, and the interface between Session Manager (SessMgr) and Online Charging Service (OCS) is the Gy interface. Note that the IMSA service and DPCA are part of SessMgr on the system and separated in the figure for illustration purpose only.



Important

In 14.0 and later releases, the DPCA and the IMSA will be acting as one module within the Policy Server interface application.

Figure 27: Rel. 7 Gx IMS Authorization Call Flow

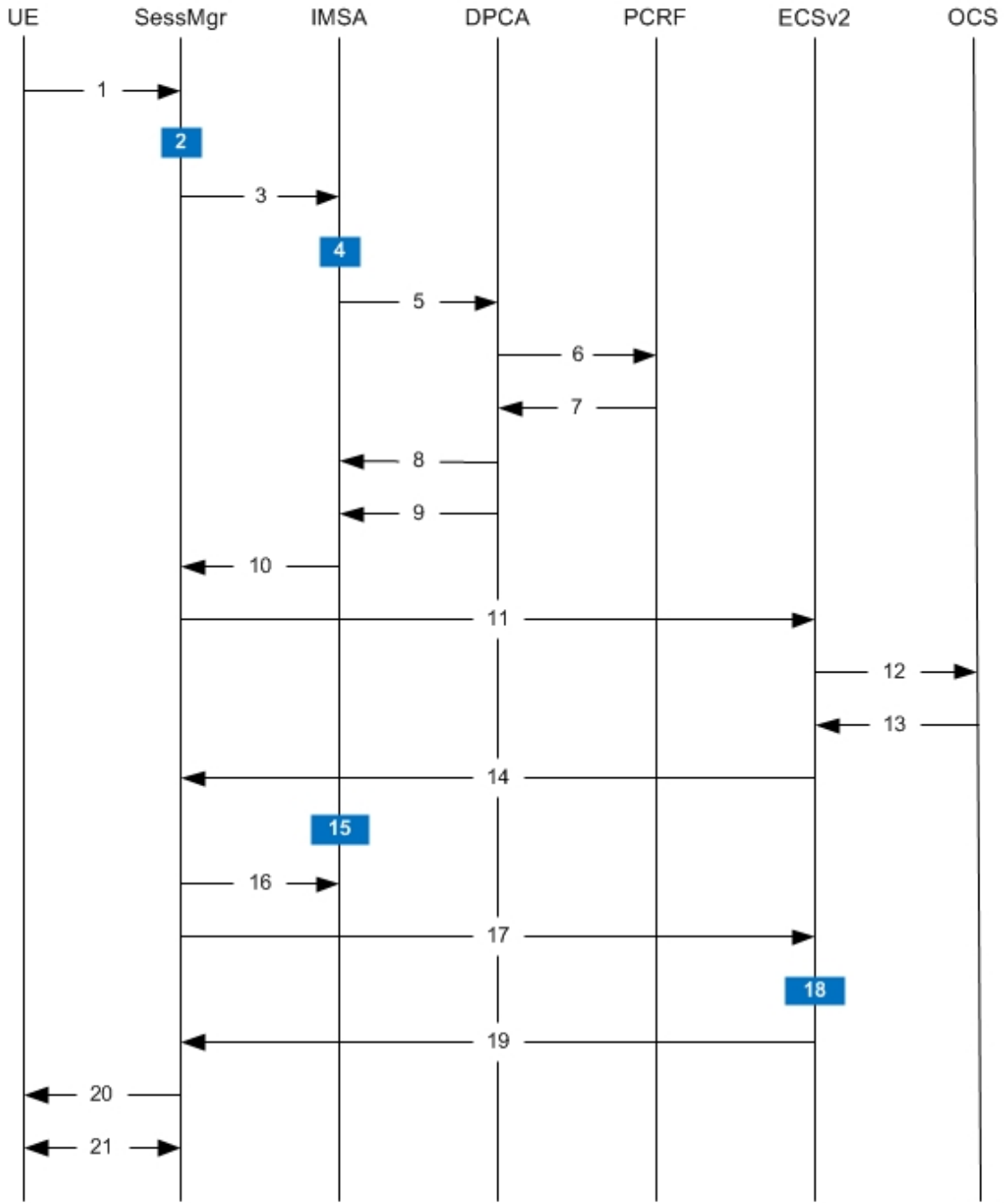

335182

Table 31: Rel. 7 Gx IMS Authorization Call flow Description

Step	Description
1	UE (IMS subscriber) requests for primary PDP context activation/creation.

Step	Description
2	SessMgr allocates an IP address to the UE.
3	SessMgr requests IMS Authorization, if IMSA is enabled for the APN.
4	IMSA allocates resources for the IP CAN session and the bearer, and selects the PCRF to contact based on the user's selection key (for example, msisdn).
5	IMSA requests the DPCA module to issue an auth request to the PCRF.
6	DPCA sends a CCR initial message to the selected PCRF. This message includes the Context-Type AVP set to PRIMARY and the IP address allocated to the UE. The message may include the Bearer-Usage AVP set to GENERAL. The Bearer-Operation is set to Establishment. The Bearer ID is included if the PCRF does the bearer binding.
7	PCRF may send preconfigured charging rules in CCA, if a preconfigured rule set for general purpose PDP context is provided in PCRF. The dynamic rules and the authorized QoS parameters could also be included by the PCRF.
8	DPCA passes the charging rule definition, charging rule install, QoS information received from the PCRF, event triggers, and so on, along with the Bearer ID that corresponds to the rules received from the PCRF to IMSA. IMSA stores the information. If the Bearer ID is absent, and PCRF does the bearer binding, the rule is skipped. Whereas, if the Bearer ID is absent and the PCEF does the bearer binding, the rule is passed onto the ECS to perform bearer binding.
9	DPCA calls the callback function registered with it by IMSA.
10	IMSA stores the bearer authorized QoS information and notifies the SessMgr. Other PCRF provided information common to the entire PDP session (event trigger, primary/secondary OCS address, and so on) is stored within the IMSA. After processing the information, IMSA notifies the SessMgr about the policy authorization complete.

Step	Description
11	If the validation of the rules fails in IMSA/DPCA, a failure is notified to PCRF containing the Charging-Rule-Report AVP. Else, IMSA initiates creation of ECS session. The APN name, primary/secondary OCS server address, and so on are sent to the ECS from the SessMgr.
12	ECS performs credit authorization by sending CCR(I) to OCS with CC-Request-Type set to INITIAL_REQUEST to open the credit control session. This request includes the active Rulebase-Id (default rulebase ID from the APN/AAA) and GPRS specific attributes (for example, APN, UMTS QoS, and so on).
13	OCS returns a CCA initial message that may activate a statically configured Rulebase and may include preemptive quotas.
14	ECS responds to SessMgr with the response message.
15	SessMgr requests IMSA for the dynamic rules.
16	<p>IMSA sends the dynamic rules to SessMgr.</p> <p>Note that, in 14.0 and later releases, the RAR messages are allowed before the session is established. In earlier releases, until the primary PDP context is established, all RAR messages from the PCRF were rejected.</p> <p>Also note that, in 14.0 and later releases, the RAR message is rejected and RAA is sent with 3002 result code when the recovery of dynamic rule information and audit of Session Manager are in progress. Earlier, the RAR messages were processed by DPCA even when the recovery audit was in progress.</p>
17	SessMgr sends the dynamic rule information to the ECS. The gate flow status information and the QoS per flow (charging rule) information are also sent in the message.
18	ECS activates the predefined rules received, and installs the dynamic rules received. Also, the gate flow status and the QoS parameters are updated by ECS as per the dynamic charging rules. The Gx rulebase is treated as an ECS group-of-ruledefs. The response message contains the Charging Rule Report conveying the status of the rule provisioning at the ECS. ECS performs PCEF bearer binding for rules without bearer ID.

Step	Description
19	If the provisioning of rules fails partially, the context setup is accepted, and a new CCR-U is sent to the PCRF with the Charging-Rule-Report containing the PCC rule status for the failed rules. If the provisioning of rules fails completely, the context setup is rejected.
20	Depending on the response for the PDP Context Authorization, SessMgr sends the response to the UE and activates/rejects the call. If the Charging-Rule-Report contains partial failure for any of the rules, the PCRF is notified, and the call is activated. If the Charging-Rule-Report contains complete failure, the call is rejected.
21	Based on the PCEF bearer binding for the PCC rules at Step 18, the outcome could be one or more network-initiated PDP context procedures with the UE (Network Requested Update PDP Context (NRUPC) / Network Requested Secondary PDP Context Activation (NRSPCA)).

Configuring Rel. 7 Gx Interface

To configure Rel. 7 Gx interface functionality, the IMS Authorization service must be configured at the context level, and then the APN configured to use the IMS Authorization service.

To configure Rel. 7 Gx interface functionality:

-
- Step 1** Configure IMS Authorization service at the context level for IMS subscriber in GPRS/UMTS network as described in [Configuring IMS Authorization Service at Context Level, on page 230](#).
 - Step 2** Verify your configuration as described in [Verifying the Configuration, on page 232](#).
 - Step 3** Configure an APN within the same context to use the IMS Authorization service for IMS subscriber as described in [Applying IMS Authorization Service to an APN, on page 232](#).
 - Step 4** Verify your configuration as described in [Verifying Subscriber Configuration, on page 233](#).
 - Step 5** *Optional:* Configure the Volume Reporting over Gx feature as described in [Configuring Volume Reporting over Gx, on page 233](#).
 - Step 6** Save your configuration to flash memory, an external memory device, and/or a network location using the Exec mode command **save configuration**. For additional information on how to verify and save configuration files, refer to the *System Administration Guide* and the *Command Line Interface Reference*.

Important Commands used in the configuration examples in this section provide base functionality to the extent that the most common or likely commands and/or keyword options are presented. In many cases, other optional commands and/or keyword options are available. Refer to the *Command Line Interface Reference* for complete information regarding all commands.

Configuring IMS Authorization Service at Context Level

Use the following example to configure IMS Authorization service at context level for IMS subscribers in GPRS/UMTS networks:

```
configure
  context <context_name>
    ims-auth-service <imsa_service_name>
      p-cscf discovery table { 1 | 2 } algorithm {
ip-address-modulus | msisdn-modulus | round-robin }
      p-cscf table { 1 | 2 } row-precedence <precedence_value> {
address <ip_address> | ipv6-address <ipv6_address> } [ secondary { address
<ip_address> | ipv6-address <ipv6_address> } ]
      policy-control
        diameter origin endpoint <endpoint_name>
        diameter dictionary <dictionary>
        diameter request-timeout <timeout_duration>
        diameter host-select table { { { 1 | 2 } algorithm {
ip-address-modulus | msisdn-modulus | round-robin } } | prefix-table {
1 | 2 } }
          diameter host-select row-precedence <precedence_value>
table { { { { 1 | 2 } host <host_name> [ realm <realm_id> ] [ secondary host
<host_name> [ realm <realm_id> ] ] } | { prefix-table { 1 | 2 }
msisdn-prefix-from <msisdn_prefix_from> msisdn-prefix-to <msisdn_prefix_to> host
<host_name> [ realm <realm_id> ] [ secondary host <sec_host_name> [ realm
<sec_realm_id> ] algorithm { active-standby | round-robin } ] } } } [ -noconfirm
]
          diameter host-select reselect subscriber-limit
<subscriber_limit> time-interval <duration>
          failure-handling cc-request-type { any-request |
initial-request | terminate-request | update-request } {
diameter-result-code { any-error | <result_code> [ to <end_result_code> ] } }
{ continue | retry-and-terminate | terminate }
        end
      end
    end
  end
```

Notes:

- <context_name> must be the name of the context where you want to enable IMS Authorization service.
- <imsa_service_name> must be the name of the IMS Authorization service to be configured for Rel. 7 Gx interface authentication.
- In releases prior to 18, a maximum of 16 authorization services can be configured globally in the system. There is also a system limit for the maximum number of total configured services. In 18 and later releases, up to a maximum of 30 IMS authorization service profiles can be configured within the system.
- Secondary P-CSCF IP address can be configured in the P-CSCF table. Refer to the *Command Line Interface Reference* for more information on the **p-cscf table** command.

In 18 and later releases, the syntax for **p-cscf table** configuration command is:

```
p-cscf table { 1 | 2 } row-precedence precedence_value { ipv4-address
ipv4_address [ ipv6-address ipv6_address ] | ipv6-address ipv6_address [
ipv4-address ipv4_address ] } [ secondary { ipv4-address ipv4_address [
```

```
ipv6-address ipv6_address ] | ipv6-address ipv6_address [ ipv4-address
ipv4_address ] } [ weight value ]
```

- To enable Rel. 7 Gx interface support, pertinent Diameter dictionary must be configured. For information on the specific Diameter dictionary to use, contact your Cisco account representative.

- When configuring the MSISDN prefix range based PCRF selection mechanism:

To enable the Gx interface to connect to a specific PCRF for a range of subscribers configure **msisdn-prefix-from** <*msisdn_prefix_from*> and **msisdn-prefix-to** <*msisdn_prefix_to*> with the starting and ending MSISDNs respectively.

To enable the Gx interface to connect to a specific PCRF for a specific subscriber, configure both **msisdn-prefix-from** <*msisdn_prefix_from*> and **msisdn-prefix-to** <*msisdn_prefix_to*> with the same MSISDN.

In StarOS 8.1 and later releases, per MSISDN prefix range table a maximum of 128 rows can be added. In StarOS 8.0 and earlier releases, a maximum of 100 rows can be added.

The MSISDN ranges must not overlap between rows.

- The Round Robin algorithm for PCRF selection is effective only over a large number of PCRF selections, and not at a granular level.
- *Optional:* To configure the Quality of Service (QoS) update timeout for a subscriber, in the IMS Authorization Service Configuration Mode, enter the following command:

```
qos-update-timeout <timeout_duration>
```



Important This command is obsolete in release 11.0 and later releases.

- *Optional:* To configure signalling restrictions, in the IMS Authorization Service Configuration Mode, enter the following commands:

```
signaling-flag { deny | permit }
```

```
signaling-flow permit server-address <ip_address> [ server-port { <port_number> | range
<start_number> to <end_number> } } ] [ description <string> ]
```

- *Optional:* To configure action on packets that do not match any policy gates in the general purpose PDP context, in the IMS Authorization Service Configuration Mode, enter the following command:

```
traffic-policy general-pdp-context no-matching-gates direction { downlink | uplink } { forward |
discard }
```

- To configure the PCRF host destinations configured in the GGSN/PCEF, use the **diameter host-select** CLI commands.
- To configure the GGSN/PCEF to use a pre-defined rule when the Gx fails, set the **failure-handling cc-request-type** CLI to **continue**. Policies available/in use will continue to be used and there will be no further interaction with the PCRF.
- For provisioning of default charging method, use the following configurations. For this, the AVPs Online and Offline will be sent in CCR-I message based on the configuration. The Online/Offline AVP received at command level applies only to dynamic rules if they are not configured at PCC rule level.

- To send Enable Online:

```

configure
active-charging service <ecs_service_name>
charging-action <charging_action_name>
cca charging credit
exit

```

- To send Enable Offline:

```

configure
active-charging service <ecs_service_name>
rulebase <rulebase_name>
billing-records rf
exit

```

Verifying the Configuration

To verify the IMS Authorization service configuration:

-
- Step 1** Change to the context where you enabled IMS Authorization service by entering the following command:

```
context <context_name>
```

- Step 2** Verify the IMS Authorization service's configurations by entering the following command:

```
show ims-authorization service name <imsa_service_name>
```

Applying IMS Authorization Service to an APN

After configuring IMS Authorization service at the context-level, an APN must be configured to use the IMS Authorization service for an IMS subscriber.

Use the following example to apply IMS Authorization service functionality to a previously configured APN within the context configured as described in [Configuring Rel. 7 Gx Interface, on page 229](#).

```

configure
  context <context_name>
    apn <apn_name>
      ims-auth-service <imsa_service_name>
      active-charging rulebase <rulebase_name>
    end

```

Notes:

- <context_name> must be the name of the context in which the IMS Authorization service was configured.
- <imsa_service_name> must be the name of the IMS Authorization service configured for IMS authentication in the context.
- For Rel. 7 Gx, the ECS rulebase must be configured in the APN.

- ECS allows change of rulebase via Gx for PCEF binding scenarios. When the old rulebase goes away, all the rules that were installed from that rulebase are removed. This may lead to termination of a few bearers (PDP contexts) if they are left without any rules. If there is a Gx message that changes the rulebase, and also activates some predefined rules, the rulebase change is made first, and the rules are activated from the new rulebase. Also, the rulebase applies to the entire call. All PDP contexts (bearers) in one call use the same ECS rulebase.
- For predefined rules configured in the ECS, MBR/GBR of a dynamic/predefined rule is checked before it is used for PCEF binding. All rules (dynamic as well as predefined) have to have an MBR associated with them and all rules with GBR QCI should have GBR also configured. So for predefined rules, one needs to configure appropriate peak-data-rate, committed-data-rate as per the QCI being GBR QCI or non-GBR QCI. For more information, in the ACS Charging Action Configuration Mode, see the **flow limit-for-bandwidth** CLI command.
- For interpretation of the Gx rulebase (Charging-Rule-Base-Name AVP) from PCRF as ECS group-of-ruledefs, configure the following command in the Active Charging Service Configuration Mode:
policy-control charging-rule-base-name active-charging-group-of-ruledefs

Verifying Subscriber Configuration

Verify the IMS Authorization service configuration for subscriber(s) by entering the following command:

```
show subscribers ims-auth-service <imsa_service_name>
```

<imsa_service_name> must be the name of the IMS Authorization service configured for IMS authentication.

Configuring Volume Reporting over Gx

This section describes the configuration required to enable Volume Reporting over Gx.

To enable Volume Reporting over Gx, use the following configuration:

```
configure
  active-charging service <ecs_service_name>
    rulebase <rulebase_name>
      action priority <priority> dynamic-only ruledef <ruledef_name>
  charging-action <charging_action_name> monitoring-key <monitoring_key>
  exit
exit
context <context_name>
  ims-auth-service <imsa_service_name>
    policy-control
      event-update send-usage-report [ reset-usage ]
    end
```

Notes:

- The maximum accepted monitoring key value by the PCEF is 4294967295. If the PCEF sends a greater value, the value is converted to an Unsigned Integer value.
- The **event-update** CLI which enables volume usage report to be sent in event updates is available only in 10.2 and later releases. The optional keyword **reset-usage** enables to support delta reporting wherein the usage is reported and reset at PCEF. If this option is not configured, the behavior is to send the usage information as part of event update but not reset at PCEF.

Gathering Statistics

This section explains how to gather Rel. 7 Gx statistics and configuration information.

In the following table, the first column lists what statistics to gather, and the second column lists the action to perform.

Table 32: Gathering Rel. 7 Gx Statistics and Information

Statistics/Information	Action to perform
Information and statistics specific to policy control in IMS Authorization service.	show ims-authorization policy-control statistics
Information and statistics specific to the authorization servers used for IMS Authorization service.	show ims-authorization servers ims-auth-service
Information of all IMS Authorization service.	show ims-authorization service all
Statistics of IMS Authorization service.	show ims-authorization service statistics
Information, configuration, and statistics of sessions active in IMS Authorization service.	show ims-authorization sessions all
Complete information, configuration, and statistics of sessions active in IMS Authorization service.	show ims-authorization sessions full
Summarized information of sessions active in IMS Authorization service.	show ims-authorization sessions summary
Complete statistics for active charging service sessions.	show active-charging sessions full
Information for all rule definitions configured in the service.	show active-charging ruledef all
Information for all rulebases configured in the system.	show active-charging rulebase all
Information on all group of ruledefs configured in the system.	show active-charging group-of-ruledefs all
Information on policy gate counters and status.	show ims-authorization policy-gate { counters status } This command is no longer an option in StarOS release 11.0 and beyond.

Rel. 8 Gx Interface

Rel. 8 Gx interface support is available on the Cisco ASR chassis running StarOS 10.0 or StarOS 11.0 and later releases.

This section describes the following topics:

- [HA/PDSN Rel. 8 Gx Interface Support, on page 235](#)
- [P-GW Rel. 8 Gx Interface Support, on page 252](#)

HA/PDSN Rel. 8 Gx Interface Support

This section provides information on configuring Rel. 8 Gx interface for HA and PDSN to support policy and charging control for subscribers in CDMA networks.

The IMS service provides application support for transport of voice, video, and data independent of access support. Roaming IMS subscribers in CDMA networks require apart from other functionality sufficient, uninterrupted, consistent, and seamless user experience during an application session. It is also important that a subscriber gets charged only for the resources consumed by the particular IMS application used.

It is recommended that before using the procedures in this section you select the configuration example that best meets your service model, and configure the required elements for that model as described in this Administration Guide.

This section describes the following topics:

- [Introduction, on page 235](#)
- [Terminology and Definitions, on page 237](#)
- [How it Works, on page 245](#)
- [Configuring HA/PDSN Rel. 8 Gx Interface Support, on page 248](#)
- [Gathering Statistics, on page 251](#)

Introduction

For IMS deployment in CDMA networks the system uses Rel. 8 Gx interface for policy-based admission control support and flow-based charging (FBC). The Rel. 8 Gx interface supports enforcing policy control features like gating, bandwidth limiting, and so on, and also supports FBC. This is accomplished via dynamically provisioned Policy Control and Charging (PCC) rules. These PCC rules are used to identify Service Data Flows (SDF) and to do charging. Other parameters associated with the rules are used to enforce policy control.

The PCC architecture allows operators to perform service-based QoS policy and FBC control. In the PCC architecture, this is accomplished mainly by the Policy and Charging Enforcement Function (PCEF)/HA/PDSN and the Policy and Charging Rules Function (PCRF). The client functionality lies with the HA/PDSN, therefore in the IMS Authorization (IMSA) scenario it is also called the Gateway. The PCEF function is provided by the Enhanced Charging Service (ECS). The Gx interface is implemented as a Diameter connection. The Gx messaging mostly involves installing/modifying/removing dynamic rules and activating/deactivating predefined rules.

The Gx reference point is located between the Gateway/PCEF and the PCRF. This reference point is used for provisioning and removal of PCC rules from the PCRF to the Gateway/PCEF, and the transmission of traffic plane events from the Gateway/PCEF to the PCRF. The Gx reference point can be used for charging control, policy control, or both by applying AVPs relevant to the application.

The following figure shows the reference points between elements involved in the policy and charging architecture.

Figure 28: HA/PDSN Rel. 8 Gx PCC Logical Architecture

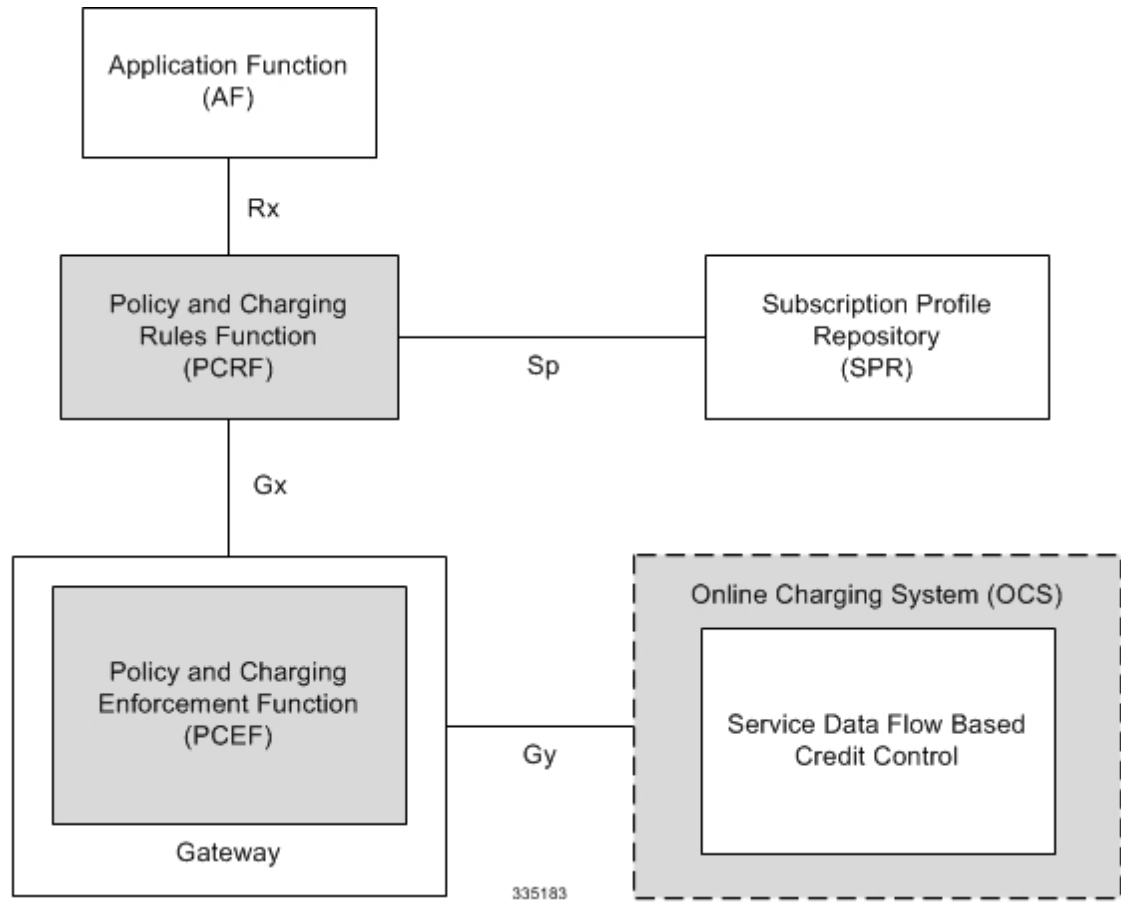

Within the Gateway, the IMSA and DPCA modules handle the Gx protocol related functions (at the SessMgr) and the policy enforcement and charging happens at ECS. The Gy protocol related functions are handled within the DCCA module (at the ECS).

The following figure shows the interaction between components within the Gateway.

Figure 29: HA/PDSN Rel. 8 Gx PCC Architecture within PCEF

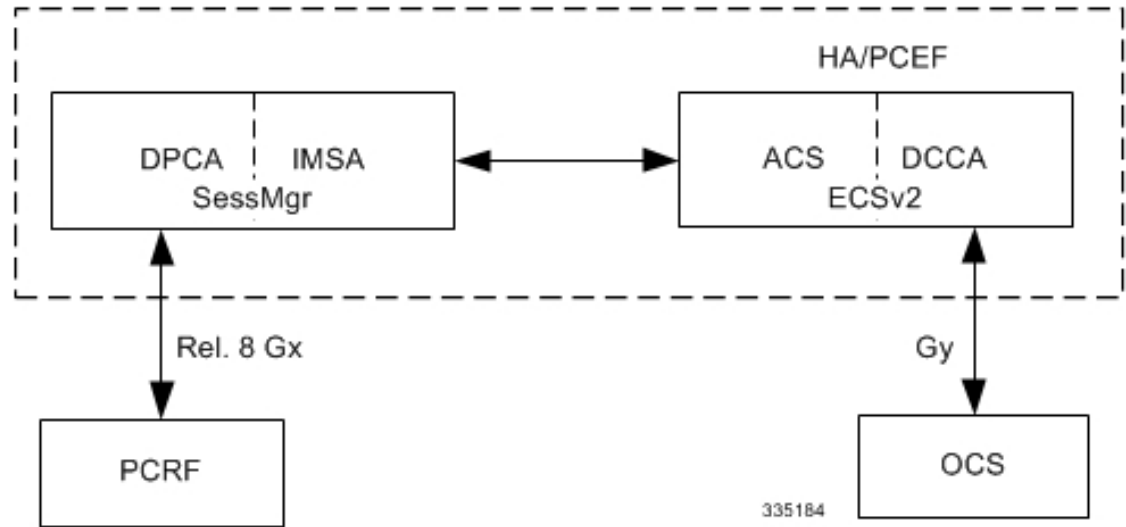

License Requirements

The HA/PDSN Rel. 8 Gx interface support is a licensed Cisco feature. A separate feature license may be required. Contact your Cisco account representative for detailed information on specific licensing requirements. For information on installing and verifying licenses, refer to the *Managing License Keys* section of the *Software Management Operations* chapter in the *System Administration Guide*.

Supported Standards

HA/PDSN Rel 8. Gx interface support is based on the following standards and RFCs:

- 3GPP TS 23.203 V8.3.0 (2008-09) 3rd Generation Partnership Project; Technical Specification Group Services and System Aspects; Policy and charging control architecture (Release 8)
- 3GPP TS 29.212 V8.6.0 (2009-12) 3rd Generation Partnership Project; Technical Specification Group Core Network and Terminals; Policy and Charging Control over Gx reference point (Release 8)
- 3GPP TS 29.213 V8.1.1 (2008-10) 3rd Generation Partnership Project; Technical Specification Group Core Network and Terminals; Policy and Charging Control signalling flows and QoS parameter mapping; (Release 8)
- RFC 3588, Diameter Base Protocol; September 2003
- RFC 4006, Diameter Credit-Control Application; August 2005

Terminology and Definitions

This section describes features and terminology pertaining to HA/PDSN Rel. 8 Gx functionality.

Policy Control

The process whereby the PCRF indicates to the PCEF how to control the IP-CAN session.

Policy control comprises the following functions:

- Binding

- Gating Control
- Event Reporting
- QoS Control
- Other Features

Binding

In the HA/PDSN Rel. 8 Gx implementation, since there are no bearers within a MIP session the IP-CAN Bearer concept does not apply. Only authorized IP-CAN session is applicable.

Gating Control

Gating control is the blocking or allowing of packets belonging to an SDF, to pass through to the desired endpoint. A gate is described within a PCC rule and gating control is applied on a per SDF basis. The commands to open or close the gate leads to the enabling or disabling of the passage for corresponding IP packets. If the gate is closed, all packets of the related IP flows are dropped. If the gate is open, the packets of the related IP flows are allowed to be forwarded.

Event Reporting



Important

Unconditional reporting of event triggers from PCRF to PCEF when PCEF has not requested for is not supported.



Important

In the HA/PDSN Rel. 8 Gx implementation, only the AN_GW_CHANGE (21) event trigger is supported.

Event reporting is the notification of and reaction to application events to trigger new behavior in the user plane as well as the reporting of events related to the resources in the Gateway (PCEF). Event triggers may be used to determine which IP-CAN session modification or specific event causes the PCEF to re-request PCC rules. Event trigger reporting from PCEF to PCRF, and provisioning of event triggers happens at IP-CAN session level.

The Event Reporting Function (ERF) located in the PCEF, receives event triggers from PCRF during the Provision of PCC Rules procedure and performs event trigger detection. When an event matching the received event trigger occurs, the ERF reports the occurred event to the PCRF. If the provided event triggers are associated with certain parameter values then the ERF includes those values in the response to the PCRF.

QoS Control



Important

In the HA/PDSN Rel. 8 Gx implementation, only authorized IP-CAN Session is supported. Provisioning of authorized QoS per IP-CAN bearer, policy enforcement for authorized QoS per QCI, and coordination of authorized QoS scopes in mixed mode are not applicable.

QoS control is the authorization and enforcement of the maximum QoS that is authorized for an SDF. In case of an aggregation of multiple SDFs, the combination of the authorized QoS information of the individual

SDFs is provided as the authorized QoS for this aggregate. QoS control per SDF allows the PCC architecture to provide the PCEF with the authorized QoS to be enforced for each specific SDF.

QoS authorization information may be dynamically provisioned by the PCRF, or it can be a predefined PCC rule in the PCEF. For a predefined PCC rule within the PCEF, the authorized QoS information takes affect when the PCC rule is activated. The PCEF combines the different sets of authorized QoS information, that is the information received from the PCRF and the information corresponding to the predefined PCC rules. The PCRF knows the authorized QoS information of the predefined PCC rules and takes this information into account when activating them. This ensures that the combined authorized QoS of a set of PCC rules that are activated by the PCRF is within the limitations given by the subscription and operator policies regardless of whether these PCC rules are dynamically provided, predefined, or both.

Supported features include:

- **Provisioning and Policy Enforcement of Authorized QoS:** The PCRF may provide authorized QoS to the PCEF. The authorized QoS provides appropriate values for resources to be enforced.
- **Policy Provisioning for Authorized QoS Per SDF:** The provisioning of authorized QoS per SDF is a part of PCC rule provisioning procedure.
- **Policy Enforcement for Authorized QoS Per SDF:** If an authorized QoS is defined for a PCC rule, the PCEF limits the data rate of the SDF corresponding to that PCC rule not to exceed the maximum authorized bandwidth for the PCC rule by discarding packets exceeding the limit.
- **Upon deactivation or removal of a PCC rule,** the PCEF frees the resources reserved for that PCC rule.

Other Features

This section describes some of the other features.

PCC Rule Error Handling

If the installation/activation of one or more PCC rules fails, the PCEF communicates the failure to the PCRF by including one or more Charging-Rule-Report AVP(s) in either a CCR or an RAA command for the affected PCC rules. Within each Charging-Rule-Report AVP, the PCEF identifies the failed PCC rule(s) by including the Charging-Rule-Name AVP(s) or Charging-Rule-Base-Name AVP(s), identifies the failed reason code by including a Rule-Failure-Code AVP, and includes the PCC-Rule-Status AVP.

If the installation/activation of one or more new PCC rules (that is, rules that were not previously successfully installed) fail, the PCEF sets the PCC-Rule-Status to INACTIVE for both the PUSH and the PULL modes.

If a PCC rule was successfully installed/activated, but can no longer be enforced by the PCEF, the PCEF sends the PCRF a new CCR command and includes the Charging-Rule-Report AVP. The PCEF includes the Rule-Failure-Code AVP within the Charging-Rule-Report AVP and sets the PCC-Rule-Status to INACTIVE.

In releases prior to 18, P-GW/GGSN does not send CCR-U with Charging Rule report for rule binding failure occurred during 4G to 3G HO in a collision case where create/update bearer response in 3G/4G is pending and update bearer of 3G HO is received. In 18 and later releases, CCR-U is generated and sent to PCRF for reporting rule failure when the collision happens during GnGp HO scenario.

This additional Gx message (CCR-U) triggered will require multiple CCR-U's to be configured when RAT_TYPE trigger is enabled. Otherwise, the subscriber call will be dropped whenever the collision happens during HO.

In the HA/PDSN Gx implementation, the following rule failure codes are supported:

- RATING_GROUP_ERROR (2)

- SERVICE_IDENTIFIER_ERROR (3)
- GW/PCEF_MALFUNCTION (4)
- RESOURCES_LIMITATION (5)

If the installation/activation of one or more PCC rules fails during RAR procedure, the RAA command is sent with the Experimental-Result-Code AVP set to DIAMETER_PCC_RULE_EVENT (5142).

Time of the Day Procedures

PCEF performs PCC rule request as instructed by the PCRF. Revalidation-Time when set by the PCRF, causes the PCEF to trigger a PCRF interaction to request PCC rules from the PCRF for an established IP-CAN session. The PCEF stops the timer once the PCEF triggers a REVALIDATION_TIMEOUT event.

When installed, the PCC rule is inactive. If Rule-Activation-Time / Rule-Deactivation-Time is specified, then the PCEF sets the rule active / inactive after that time.

In releases prior to 17.0, if "Rule-Deactivation-Time" AVP for a predefined rule was omitted in a CCA-U or RAR message, then any previous value for this AVP was continued to be used in the chassis. In 17.0 and later releases, if Rule-Deactivation-Time AVP is omitted in CCA/RAR, then any previous value for this AVP is no longer valid. The new behavior is compliant to the 3GPP specification for Gx, version 12.1.0.

If PCRF enables the same predefined rule again in RAR/CCA-U without Rule-Deactivation-Time AVP, then the deactivation-time for this rule, if any, will be removed.

For switching to the old behavior, PCRF should re-send the same value of Rule-Deactivation-Time AVP along with predef-rule name in the PCRF message (RAR, CCA-U).



Note This behavior change is applicable only to predefined rules.

Support for Firewall Policy on Gx

The Diameter AVP "SN-Firewall-Policy" has been added to the Diameter dynamic dictionary to support Firewall policy on Gx interface. This AVP can be encoded in CCA-I message to apply/overwrite the fw-and-nat policy that has either been statically assigned to the PDP context via APN configuration or dynamically assigned via RADIUS in Access-Accept. This AVP can also be parsed in any CCA-U or RAR message to modify the fw-and-nat policy that is currently assigned to the PDP context.

Charging Control



Important In the HA/PDSN Rel. 8 Gx implementation, offline charging is not supported.

Charging Control is the process of associating packets belonging to an SDF to a charging key, and applying online charging as appropriate. FBC handles differentiated charging of the bearer usage based on real-time analysis of the SDFs. In order to allow for charging control, the information in the PCC rule identifies the SDF and specifies the parameters for charging control. The PCC rule information may depend on subscription data.

Online charging is supported via the Gy interface. In the case of online charging, it is possible to apply an online charging action upon PCEF events (for example, re-authorization upon QoS change).

It is possible to indicate to the PCEF that interactions with the charging systems are not required for a PCC rule, that is to perform neither accounting nor credit control for this SDF, then neither online nor offline charging is performed.

Supported Features:

- Provisioning of charging-related information for the IP-CAN Session
- Provisioning of charging addresses: Primary or secondary event charging function name (Online Charging Server (OCS) addresses)



Important In the HA/PDSN Rel. 8 Gx implementation, provisioning of primary or secondary charging collection function name (Offline Charging Server (OFCS) addresses) over Gx is not supported.

- Provisioning of Default Charging Method: In this release, the default charging method is sent in CCR-I message. For this, new AVPs Online/Offline are sent in CCR-I message based on the configuration. The Online/Offline AVP received at command level applies only to dynamic rules if they are not configured at PCC rule level.

Charging Correlation

In the HA/PDSN Rel. 8 Gx implementation, Charging Correlation is not supported. PCRF provides the flow identifier, which uniquely identifies an IP flow in an IMS session.

Policy and Charging Control (PCC) Rules

A PCC rule enables the detection of an SDF and provides parameters for policy control and/or charging control. The purpose of the PCC rule is to:

- Detect a packet belonging to an SDF in case of both uplink and downlink IP flows based on SDF filters in the PCC rule (packet rule matching).

If no PCC rule matches the packet, the packet is dropped.

- Identify the service that the SDF contributes to.
- Provide applicable charging parameters for an SDF.
- Provide policy control for an SDF.

The PCEF selects a PCC rule for each packet received by evaluating received packets against SDF filters of PCC rules in the order of precedence of the PCC rules. When a packet matches an SDF filter, the packet matching process for that packet is completed, and the PCC rule for that filter is applied.

There are two types of PCC rules:

- **Dynamic PCC Rules:** Rules dynamically provisioned by the PCRF to the PCEF via the Gx interface. These PCC rules may be either predefined or dynamically generated in the PCRF. Dynamic PCC rules can be activated, modified, and deactivated at any time.
- **Predefined PCC Rule:** Rules preconfigured in the PCEF by the operators. Predefined PCC rules can be activated or deactivated by the PCRF at any time. Predefined PCC rules within the PCEF may be grouped allowing the PCRF to dynamically activate a set of PCC rules over the Gx reference point.

**Important**

A third kind of rule, the static PCC rule can be preconfigured in the chassis by the operators. Static PCC rules are not explicitly known in the PCRF, and are not under control of the PCRF. Static PCC rules are bound to general purpose bearer with no Gx control.

A PCC rule consists of:

- **Rule Name:** The rule name is used to reference a PCC rule in the communication between the PCEF and PCRF.
- **Service Identifier:** The service identifier is used to identify the service or the service component the SDF relates to.
- **Service Data Flow Filter(s):** The service flow filter(s) is used to select the traffic for which the rule applies.
- **Precedence:** For different PCC rules with overlapping SDF filter, the precedence of the rule determines which of these rules is applicable. When a dynamic PCC rule and a predefined PCC rule have the same priority, the dynamic PCC rule takes precedence.
- **Gate Status:** The gate status indicates whether the SDF, detected by the SDF filter(s), may pass (gate is open) or will be discarded (gate is closed) in uplink and/or in downlink direction.
- **QoS Parameters:** The QoS information includes the QoS class identifier (authorized QoS class for the SDF), and authorized bitrates for uplink and downlink.
- **Charging Key (rating group)**
- **Other charging parameters:** The charging parameters define whether online charging interfaces are used, on what level the PCEF will report the usage related to the rule, etc.

**Important**

Configuring the Metering Method and Reporting Level for dynamic PCC rules is not supported.

PCC rules also include Application Function (AF) record information for enabling charging correlation between the application and bearer layer if the AF has provided this information via the Rx interface. For IMS, this includes the IMS Charging Identifier (ICID) and flow identifiers.

**Important**

ASR 5500 supports only eight flow information including the flow description per dynamic charging rule in a Gx message.

In releases prior to 14.0, there were only 10 PCC rules that were recovered per bearer in the event of a session manager crash. In 14.0 and later releases, this limit has been increased to 24. That is, up to 24 PCC rules can be recovered post ICSR.

With the increase in the limit of PCC rules that can be recovered, the rules are not lost and hence the charging applied to the end users are not impacted.

In releases prior to 17.0, when P-GW received PCC rules from PCRF and it results in Create Bearer or Update Bearer to be triggered towards MME/S-GW, the PCC rules were kept in a pending-active state. Any modification request that was received for these pending-active rules were not currently honored by the P-GW.

In 17.0 and later releases, when modification for the PCC rules in pending-active state is received, the modified parameters will be buffered at P-GW. After the response for the pending request is received from the access network, P-GW will process the modification of the buffered parameters and if required generate another update towards network.

PCC Procedures over Gx Reference Point

Request for PCC Rules

The PCEF, via the Gx reference point, requests for PCC rules in the following instances:

- At IP-CAN session establishment
- At IP-CAN session modification

PCC rules can also be requested as a consequence of a failure in the PCC rule installation/activation or enforcement without requiring an event trigger.

Provisioning of PCC Rules

The PCRF indicates, via the Rel. 8 Gx reference point, the PCC rules to be applied at the PCEF. This may be using one of the following procedures:

- PULL (provisioning solicited by the PCEF): In response to a request for PCC rules being made by the PCEF, the PCRF provisions PCC rules in the CC-Answer.
- PUSH (unsolicited provisioning): The PCRF may decide to provision PCC rules without obtaining a request from the PCEF. For example, in response to information provided to the PCRF via the Rx reference point, or in response to an internal trigger within the PCRF. To provision PCC rules without a request from the PCEF, the PCRF includes these PCC rules in an RA-Request message. No CCR/CCA messages are triggered by this RA-Request.

For each request from the PCEF or upon unsolicited provisioning, the PCRF provisions zero or more PCC rules. The PCRF may perform an operation on a single PCC rule by one of the following means:

- To activate or deactivate a PCC rule that is predefined at the PCEF, the PCRF provisions a reference to this PCC rule within a Charging-Rule-Name AVP and indicates the required action by choosing either the Charging-Rule-Install AVP or the Charging-Rule-Remove AVP.
- To install or modify a PCRF-provisioned PCC rule, the PCRF provisions a corresponding Charging-Rule-Definition AVP within a Charging-Rule-Install AVP.
- To remove a PCC rule which has previously been provisioned by the PCRF, the PCRF provisions the name of this rule as value of a Charging-Rule-Name AVP within a Charging-Rule-Remove AVP.



Important

In 11.0 and later releases, the maximum valid length for a charging rule name is 63 bytes. When the length of the charging rule name is greater than 63 bytes, a charging rule report with RESOURCES_LIMITATION as Rule-Failure-Code is sent. This charging rule report is sent only when the length of the rule name is lesser than 128 characters. When the charging rule name length is greater than or equal to 128 characters no charging rule report will be sent. In earlier releases, the length of the charging rule name constructed by PCRF was limited to 32 bytes.

Releases prior to 14.0, when PCRF has subscribed to Out of Credit trigger, on session connect when one rule validation fails and also when an Out of Credit was received from OCS for another rule, P-GW was trying to report these failures in different CCR-U to PCRF. However, the second CCR-U of Out of credit was getting dropped internally.

In 14.0 and later releases, on session connect, P-GW combines the rule failure and out of credit in the same CCR-U and sends to PCRF.

Selecting a PCC Rule for Uplink IP Packets

If PCC is enabled, the PCEF selects the applicable PCC rule for each received uplink IP packet within an IP-CAN session by evaluating the packet against uplink SDF filters of PCRF-provided or predefined active PCC rules of this IP-CAN session in the order of the precedence of the PCC rules.



Important

When a PCRF-provided PCC rule and a predefined PCC rule have the same precedence, the uplink SDF filters of the PCRF-provided PCC rule is applied first.

When a packet matches an SDF filter, the packet matching process for that packet is completed, and the PCC rule for that filter is applied. Uplink IP packets which do not match any PCC rule of the corresponding IP-CAN session are discarded.

Selecting a PCC Rule for Downlink IP Packets

If PCC is enabled, the PCEF selects a PCC rule for each received downlink IP packet within an IP-CAN session by evaluating the packet against downlink SDF filters of PCRF-provided or predefined active PCC rules of the IP-CAN session in the order of precedence of the PCC rules.



Important

When a PCRF-provided PCC rule and a predefined PCC rule have the same precedence, the downlink SDF filters of the PCRF-provided PCC rule are applied first.

When a packet matches an SDF filter, the packet matching process for that packet is completed, and the PCC rule for that filter is applied. Downlink IP packets that do not match any PCC rule of the IP-CAN session are discarded.

The following procedures are also supported:

- **Indication of IP-CAN Session Termination:** When the IP-CAN session is being terminated the PCEF contacts the PCRF.
- **Request of IP-CAN Session Termination:** If the PCRF decides to terminate an IP-CAN session due to an internal trigger or trigger from the SPR, the PCRF informs the PCEF. The PCEF acknowledges to the PCRF and instantly removes/deactivates all the PCC rules that have been previously installed or activated on that IP-CAN session.

The PCEF applies IP-CAN specific procedures to terminate the IP-CAN session. The HA/PDSN sends a MIP Revocation Request with the teardown indicator set to indicate that the termination of the entire IP-CAN session is requested. Furthermore, the PCEF applies the "Indication of IP-CAN Session Termination" procedure.

- **Use of the Supported-Features AVP during session establishment** to inform the destination host about the required and optional features that the origin host supports.

How it Works

This section describes how HA/PDSN Rel. 8 Gx Interface support works.

The following figure and table explain the IMS Authorization process between a system and IMS components that is initiated by the UE.

In this example, the Diameter Policy Control Application (DPCA) is the Gx interface to the PCRF. The interface between IMSA with PCRF is the Gx interface, and the interface between Session Manager (SessMgr) and Online Charging Service (OCS) is the Gy interface. Note that the IMSA service and DPCA are part of SessMgr on the system and separated in the figure for illustration purpose only.



Important

In 14.0 and later releases, the DPCA and the IMSA will be acting as one module within the Policy Server interface application.

Figure 30: HA/PDSN Rel. 8 Gx IMS Authorization Call Flow

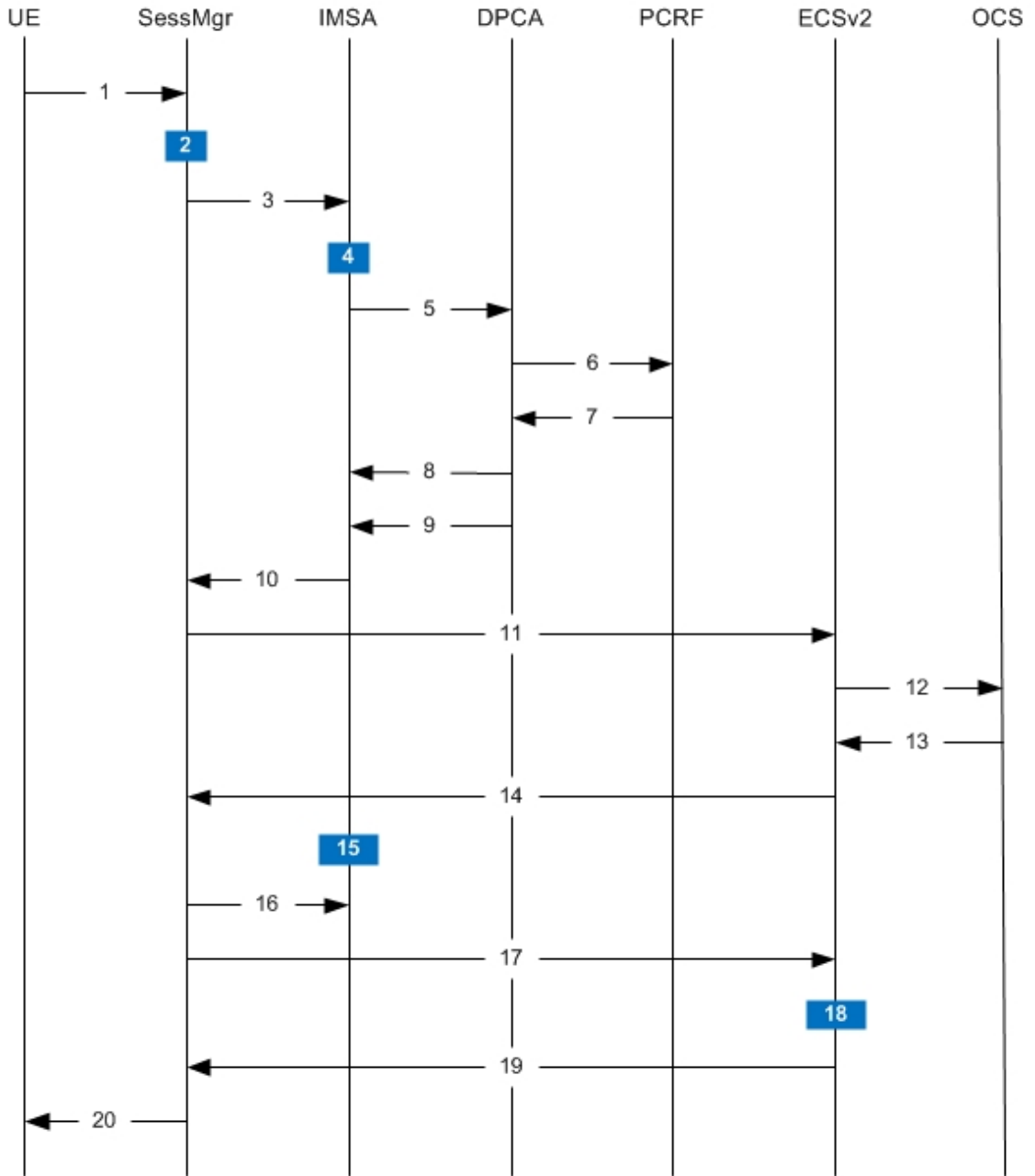

335185

Table 33: HA/PDSN Rel. 8 Gx IMS Authorization Call flow Description

Step	Description
1	UE (IMS subscriber) requests for MIP Registration Request.
2	SessMgr allocates an IP address to the UE.

Step	Description
3	<p>SessMgr requests IMS Authorization, if IMSA is enabled for the subscriber.</p> <p>IMSA service can either be configured in the subscriber template, or can be received from the AAA.</p>
4	<p>IMSA allocates resources for the IP-CAN session, and selects the PCRF to contact based on the user's selection key (for example, round-robin).</p>
5	<p>IMSA requests the DPCA module to issue an auth request to the PCRF.</p>
6	<p>DPCA sends a CCR initial message to the selected PCRF.</p>
7	<p>PCRF may send preconfigured charging rules in CCA. The dynamic rules and the authorized QoS parameters could also be included by the PCRF.</p>
8	<p>DPCA passes the charging rule definition, charging rule install, QoS information received from the PCRF, event triggers, etc. IMSA stores the information.</p>
9	<p>DPCA calls the callback function registered with it by IMSA.</p>
10	<p>PCRF-provided information common to the entire IP-CAN session (event trigger, primary/secondary OCS address, etc.) is stored within the IMSA. After processing the information, IMSA notifies the SessMgr about the policy authorization complete.</p>
11	<p>If the validation of the rules fails in IMSA/DPCA, a failure is notified to PCRF containing the Charging-Rule-Report AVP. Else, IMSA initiates creation of ECS session. The primary/secondary OCS server address, etc. are sent to the ECS from the SessMgr.</p>
12	<p>ECS performs credit authorization by sending CCR(I) to OCS with CC-Request-Type set to INITIAL_REQUEST to open the credit control session. This request includes the active Rulebase-Id (default rulebase ID from the AAA).</p>
13	<p>OCS returns a CCA initial message that may activate a statically configured Rulebase and may include preemptive quotas.</p>
14	<p>ECS responds to SessMgr with the response message.</p>

Step	Description
15	SessMgr requests IMSA for the dynamic rules.
16	<p>IMSA sends the dynamic rules to SessMgr.</p> <p>Note that, in 14.0 and later releases, the RAR messages are allowed before the session is established. In earlier releases, until the MIP session is established, all RAR messages from the PCRF were rejected.</p> <p>Also note that, in 14.0 and later releases, the RAR message is rejected and RAA is sent with 3002 result code when the recovery of dynamic rule information and audit of Session Manager are in progress. Earlier, the RAR messages were processed by DPCA even when the recovery audit was in progress.</p>
17	SessMgr sends the dynamic rule information to the ECS. The gate flow status information and the QoS per flow (charging rule) information are also sent in the message.
18	ECS activates the predefined rules received, and installs the dynamic rules received. Also, the gate flow status and the QoS parameters are updated by ECS as per the dynamic charging rules. The Gx rulebase is treated as an ECS group-of-ruledefs. The response message contains the Charging Rule Report conveying the status of the rule provisioning at the ECS.
19	If the provisioning of rules fails partially, the context setup is accepted, and a new CCR-U is sent to the PCRF with the Charging-Rule-Report containing the PCC rule status for the failed rules. If the provisioning of rules fails completely, the context setup is rejected.
20	Depending on the response for the MIP Session Authorization, SessMgr sends the response to the UE and activates/rejects the call. If the Charging-Rule-Report contains partial failure for any of the rules, the PCRF is notified, and the call is activated. If the Charging-Rule-Report contains complete failure, the call is rejected.

Configuring HA/PDSN Rel. 8 Gx Interface Support

To configure HA/PDSN Rel. 8 Gx Interface functionality:

1. At the context level, configure IMSA service for IMS subscribers as described in [Configuring IMS Authorization Service at Context Level](#), on page 249.

2. Within the same context, configure the subscriber template to use the IMSA service as described in [Applying IMS Authorization Service to Subscriber Template, on page 250](#).
3. Save your configuration to flash memory, an external memory device, and/or a network location using the Exec mode command **save configuration**. For additional information on how to verify and save configuration files, refer to the *System Administration Guide* and the *Command Line Interface Reference*.

**Important**

Commands used in the configuration examples in this section provide base functionality to the extent that the most common or likely commands and/or keyword options are presented. In many cases, other optional commands and/or keyword options are available. Refer to the *Command Line Interface Reference* for complete information regarding all commands.

Configuring IMS Authorization Service at Context Level

Use the following example to configure IMSA service at context level for IMS subscribers:

```

configure
  context <context_name>
    ims-auth-service <imsa_service_name>
      policy-control
        diameter origin endpoint <endpoint_name>
        diameter dictionary <dictionary>
        diameter request-timeout <timeout_duration>
        diameter host-select table { 1 | 2 } algorithm
round-robin
        diameter host-select row-precedence <precedence_value>
table { 1 | 2 } host <primary_host_name> [ realm <primary_realm_id> ] [ secondary
  host <secondary_host_name> [ realm <secondary_realm_id> ] ] [ -noconfirm ]
        failure-handling cc-request-type { any-request |
initial-request | terminate-request | update-request } {
diameter-result-code { any-error | <result_code> [ to <end_result_code> ] } }
{ continue | retry-and-terminate | terminate }
      exit
    exit
    diameter endpoint <endpoint_name> [ -noconfirm ]
    origin realm <realm_name>
    use-proxy
    origin host <host_name> address <ip_address>
    no watchdog-timeout
    response-timeout <timeout_duration>
    connection timeout <timeout_duration>
    connection retry-timeout <timeout_duration>
    peer <primary_peer_name> [ realm <primary_realm_name> ] address
<ip_address> [ port <port_number> ]
    peer <secondary_peer_name> [ realm <secondary_realm_name> ] address
<ip_address> [ port <port_number> ]
    end

```

Notes:

- <context_name> must be the name of the context where you want to enable IMSA service.

- *<imsa_service_name>* must be the name of the IMSA service to be configured for Rel. 8 Gx interface authentication.
- In releases prior to 18, a maximum of 16 authorization services can be configured globally in the system. There is also a system limit for the maximum number of total configured services. In 18 and later releases, up to a maximum of 30 IMS authorization service profiles can be configured within the system.
- To enable Rel. 8 Gx interface support, pertinent Diameter dictionary must be configured. For information on the specific Diameter dictionary to use, contact your Cisco account representative.
- The Round Robin algorithm for PCRF selection is effective only over a large number of PCRF selections, and not at a granular level.
- To configure the PCRF host destinations configured in the PCEF, use the **diameter host-select** CLI command.
- To configure the PCEF to use a pre-defined rule when the Gx fails, set the **failure-handling cc-request-type** CLI to **continue**. Policies available/in use will continue to be used and there will be no further interaction with the PCRF.

Verifying the IMSA Service Configuration

To verify the IMSA service configuration:

1. Change to the context where you enabled IMSA service by entering the following command:

```
context <context_name>
```

2. Verify the IMSA service configuration by entering the following command:

```
show ims-authorization service name <imsa_service_name>
```

Applying IMS Authorization Service to Subscriber Template

After configuring IMSA service at the context-level, within the same context subscriber template must be configured to use the IMSA service for IMS subscribers.

Use the following example to apply IMSA service functionality to subscriber template within the context configured as described in [Configuring IMS Authorization Service at Context Level, on page 249](#).

```
configure
context <context_name>
  subscriber default
    encrypted password <encrypted_password>
    ims-auth-service <imsa_service_name>
    ip access-group <access_group_name> in
    ip access-group <access_group_name> out
    ip context-name <context_name>
    mobile-ip home-agent <ip_address>
    active-charging rulebase <rulebase_name>
end
```

Notes:

- *<context_name>* must be the name of the context in which the IMSA service was configured.

- *<imsa_service_name>* must be the name of the IMSA service configured for IMS authentication in the context.
- The ECS rulebase must be configured in the subscriber template.
- For interpretation of the Gx rulebase (Charging-Rule-Base-Name AVP) from PCRF as ECS group-of-ruledefs, configure the following command in the Active Charging Service Configuration Mode:
policy-control charging-rule-base-name active-charging-group-of- ruledefs

Verifying the Subscriber Configuration

Verify the IMSA service configuration for subscriber(s) by entering the following command in the Exec CLI configuration mode:

```
show subscribers ims-auth-service <imsa_service_name>
```

Notes:

- *<imsa_service_name>* must be the name of the IMSA service configured for IMS authentication.

Gathering Statistics

This section explains how to gather Rel. 8 Gx statistics and configuration information.

In the following table, the first column lists what statistics to gather, and the second column lists the action to perform.

Table 34: Gathering HA/PDSN Rel. 8 Gx Statistics and Information

Statistics/Information	Action to perform
Information and statistics specific to policy control in IMS Authorization service.	show ims-authorization policy-control statistics
Information and statistics specific to the authorization servers used for IMS Authorization service.	show ims-authorization servers ims-auth-service
Information of all IMS Authorization service.	show ims-authorization service all
Statistics of IMS Authorization service.	show ims-authorization service statistics
Information, configuration, and statistics of sessions active in IMS Authorization service.	show ims-authorization sessions all
Complete information, configuration, and statistics of sessions active in IMS Authorization service.	show ims-authorization sessions full
Summarized information of sessions active in IMS Authorization service.	show ims-authorization sessions summary
Complete statistics for active charging service sessions.	show active-charging sessions full
Information for all rule definitions configured in the service.	show active-charging ruledef all

Statistics/Information	Action to perform
Information for all rulebases configured in the system.	show active-charging rulebase all
Information on all group of ruledefs configured in the system.	show active-charging group-of-ruledefs all
Information on policy gate counters and status.	show ims-authorization policy-gate { counters status } This command is no longer an option in StarOS release 11.0 and beyond.

P-GW Rel. 8 Gx Interface Support

Introduction

The Gx reference point is located between the Policy and Charging Rules Function (PCRF) and the Policy and Charging Enforcement Function (PCEF) on the Packet Data Network (PDN) Gateway (P-GW). The Gx reference point is used for provisioning and removal of PCC rules from the PCRF to the PCEF and the transmission of traffic plane events from the PCEF to the PCRF. The Gx reference point can be used for charging control, policy control, or both, by applying AVPs relevant to the application.

The PCEF is the functional element that encompasses policy enforcement and flow based charging functionality. This functional entity is located at the P-GW. The main functions include:

- Control over the user plane traffic handling at the gateway and its QoS.
- Service data flow detection and counting, as well as online and offline charging interactions.
- For a service data flow that is under policy control, the PCEF allows the service data flow to pass through the gateway if and only if the corresponding gate is open.
- For a service data flow that is under charging control, the PCEF allows the service data flow to pass through the gateway if and only if there is a corresponding active PCC rule and, for online charging, the OCS has authorized the applicable credit with that charging key.
- If requested by the PCRF, the PCEF will report to the PCRF when the status of the related service data flow changes.
- In case the SDF is tunnelled at the BBERF, the PCEF informs the PCRF about the mobility protocol tunnelling header of the service data flows at IP-CAN session establishment.

Terminology and Definitions

This section describes features and terminology pertaining to Rel. 8 Gx functionality.

Volume Reporting Over Gx

This section describes the 3GPP Rel. 9 Volume Reporting over Gx feature.

License Requirements

The Volume Reporting over Gx is a licensed Cisco feature. A separate feature license may be required. Contact your Cisco account representative for detailed information on specific licensing requirements. For information on installing and verifying licenses, refer to the *Managing License Keys* section of the *Software Management Operations* chapter in the *System Administration Guide*.



Important

In 12.0 and later releases, no separate license is required for Charging over Gx / Volume Reporting over Gx feature. This feature can be enabled as part of "Policy Interface" license.

Supported Standards

The Volume Reporting over Gx feature is based on the following standard:

3GPP TS 29.212 V9.5.0 (2010-06): 3rd Generation Partnership Project; Technical Specification Group Core Network and Terminals; Policy and Charging Control over Gx reference point (Release 9).

Feature Overview

The Volume Reporting over Gx feature provides PCRF the capability to make real-time decisions based on the data usage by subscribers.



Important

Volume Reporting over Gx is applicable only for volume quota.

In release 10.0, only total data usage reporting is supported, uplink/downlink level reporting is not supported. In 10.2 and later releases, it is supported.

The PCEF only reports the accumulated usage since the last report for usage monitoring and not from the beginning.

If the usage threshold is set to zero (infinite threshold), no further threshold events will be generated by PCEF, but monitoring of usage will continue and be reported at the end of the session.

In 12.2 and later releases, usage reporting on bearer termination is supported.

The following steps explain how Volume Reporting over Gx works:

1. PCEF after receiving the message from PCRF parses the usage monitoring related AVPs, and sends the information to IMSA.
2. IMSA updates the information to ECS.
3. Once the ECS is updated with the usage monitoring information from PCRF, the PCEF (ECS) starts tracking the data usage.
4. For session-level monitoring, the ECS maintains the amount of data usage.
5. For PCC rule monitoring, usage is monitored with the monitoring key as the unique identifier. Each node maintains the usage information per monitoring key. When the data traffic is passed, the usage is checked against the usage threshold values and reported as described in the *Usage Reporting* section.
6. The PCEF continues to track data usage after the threshold is reached and before a new threshold is provided by the PCRF. If a new usage threshold is not provided by the PCRF in the acknowledgement of

an IP-CAN Session modification where its usage was reported, then usage monitoring does not continue in the PCEF for that IP CAN session.

Usage Monitoring

- Usage Monitoring at Session Level: PCRF subscribes to the session-level volume reporting over Gx by sending the Usage-Monitoring-Information AVP with the usage threshold level set in Granted-Service-Unit AVP and Usage-Monitoring-Level AVP set to SESSION_LEVEL(0). After the AVPs are parsed by DPCA, IMSA updates the information to ECS. Once ECS is updated usage monitoring is started and constantly checked with the usage threshold whenever the data traffic is present. In 11.0 and later releases, Monitoring Key at session level is supported.

In 12.0 and later releases, enabling and disabling session usage in a single message from PCRF is supported. This is supported only if the monitoring key is associated at session level.

In 12.0 and later releases, monitoring of usage based on input/output octet threshold levels is supported. Usage is reported based on the enabled threshold level. If multiple levels are enabled, usage will be reported on all the enabled levels even if only one of the levels is breached. Monitoring will be stopped on the missing threshold levels in the response for the usage report from PCRF (expected to provide the complete set again if PCRF wants to continue monitoring on the multiple levels enabled earlier).

Total threshold level along with UL/DL threshold level in the GSU AVP is treated as an error and only total threshold level is accepted.

In releases prior to 17.0, extra CCR-U was generated for a monitoring key when the following requests are received in the response to the CCR-U which reported the usage for the same monitoring key.

- immediate reporting request with monitoring key at rule level
- immediate reporting request with or without monitoring key at session level
- explicit disable request at rule level
- explicit disable request at session level

In 17.0 and later releases, extra CCR-U is not generated for a monitoring key when all the above mentioned requests are received in the response to the CCR-U which reported the usage for the same monitoring key. Also, extra CCR-U is not generated when immediate reporting request without monitoring key at rule level is received in the response to the CCR-U which reported the usage for all the active monitoring keys.

- Usage Monitoring at Flow Level: PCRF subscribes to the flow-level volume reporting over Gx by sending the Usage-Monitoring-Information AVP with the usage threshold level set in Granted-Service-Unit AVP and Usage-Monitoring-Level AVP set to PCC_RULE_LEVEL(1). Monitoring Key is mandatory in case of a flow-level monitoring since the rules are associated with the monitoring key and enabling/disabling of usage monitoring at flow level can be controlled by PCRF using it. After the AVPs are parsed by DPCA, IMSA updates the information to ECS. Once ECS is updated usage monitoring is started and constantly checked with the usage threshold whenever the data traffic is present.

Usage monitoring is supported for static, predefined rules, and dynamic rule definitions.

- Usage Monitoring for Static Rules: In the case of static rules, the usage reporting on last rule removal associated with the monitoring key is not applicable. In this case only the usage monitoring information is received from the PCRF.
- Usage Monitoring for Predefined Rules: If the usage monitoring needs to be enabled for the predefined rules, PCRF sends the rule and the usage monitoring information containing the monitoring key and the usage threshold. The Monitoring key should be same as the one pre-configured in PCEF for that predefined rule. There can be multiple rules associated with the same monitoring key. Hence

enabling a particular monitoring key would result in the data being tracked for multiple rules having the same monitoring key. After DPCA parses the AVPs IMSA updates the information to ECS. Once ECS is updated usage monitoring is started and constantly checked with the usage threshold whenever the data traffic is present.

- Usage Monitoring for Dynamic Rules: If the usage monitoring needs to be enabled for dynamic ruledefs, PCRF provides the monitoring key along with a charging rule definition and the usage monitoring information containing the monitoring key and the usage threshold. This would result in the usage monitoring being done for all the rules associated with that monitoring key. After DPCA parses the AVPs, IMSA updates the information to ECS. Once ECS is updated, the usage monitoring is started and constantly checked with the usage threshold whenever the data traffic is present. Monitoring key for dynamic ruledef is dynamically assigned by PCRF which is the only difference with predefined rules in case of usage monitoring.

In releases prior to 15.0, when threshold breach happens for multiple monitoring keys at the same time, only one of the monitoring keys' usage is reported and the rest of the monitoring keys' usage is reported in CCR-T (threshold set to infinity). On Tx expiry/TCP link error, unreported usage is stored at ECS and reported only on session termination.

In 15.0 and later releases, only one of the monitoring keys' usage is reported first. Upon receiving successful response from PCRF, the rest of the monitoring keys' usage is reported to PCRF. On Tx expiry/TCP link error, unreported usage is stored at ECS. Any future successful interaction with PCRF for the session will send unreported UMI to PCRF.

Usage Reporting

Usage at subscriber/flow level is reported to PCRF under the following conditions:

- Usage Threshold Reached: PCEF records the subscriber data usage and checks if the usage threshold provided by PCRF is reached. This is done for both session and rule level reporting.

For session-level reporting, the actual usage volume is compared with the usage volume threshold.

For rule-level reporting the rule that hits the data traffic is used to find out if the monitoring key is associated with it, and based on the monitoring key the data usage is checked. Once the condition is met, it reports the usage information to IMSA and continues monitoring. IMSA then triggers the CCR-U if "USAGE_REPORT" trigger is enabled by the PCRF. The Usage-Monitoring-Information AVP is sent in this CCR with the "Used-Service-Unit" set to the amount of data usage by subscriber.

If PCRF does not provide a new usage threshold in the usage monitoring information as a result of CCR from PCEF when the usage threshold is reached, the usage monitoring is stopped at PCEF and no usage status is reported.

In the non-standard Volume Reporting over Gx implementation, usage monitoring will be stopped once the threshold is breached, else the monitoring will continue. There will be no further usage reporting until the CCA is received.

- Usage Monitoring Disabled: If the PCRF explicitly disables the usage monitoring with Usage-Monitoring-Support AVP set to USAGE_MONITORING_DISABLED, the PCEF stops monitoring and reports the usage information (when the monitoring was enabled) to PCRF if the usage monitoring is disabled by PCRF as a result of CCR from PCEF which is not related to reporting usage, other external triggers, or a PCRF internal trigger. If the PCRF does not provide a new usage threshold as a result of CCR from PCEF when the usage threshold is reached, the usage monitoring is stopped at PCEF and no further usage status is reported.

- **IP CAN Session Termination:** When the IP CAN session is terminated, the accumulated subscriber usage information is reported to PCRF in the CCR-T from PCEF. If PCC usage level information is enabled by PCRF, the PCC usage will also be reported.

PCRF uses RAR message and includes Session-Release-Cause AVP in it to initiate IP CAN Session Termination. However, there are some scenarios where PCRF may want to terminate the IP CAN Session in CCA messages. In order to avoid an unnecessary additional message, PCRF can inform P-GW to terminate the subscriber in CCA-U message itself. Hence, in 17.0 and later releases, the Session Release Cause has been added in CCA messages for all Gx dictionaries.

- **PCC Rule Removal:** When the PCRF deactivates the last PCC rule associated with a usage monitoring key, the PCEF sends a CCR with the data usage for that monitoring key. If the PCEF reports the last PCC rule associated with a usage monitoring key is inactive, the PCEF reports the accumulated usage for that monitoring key within the same CCR command if the Charging-Rule-Report AVP was included in a CCR command; otherwise, if the Charging-Rule-Report AVP was included in an RAA command, the PCEF sends a new CCR command to report accumulated usage for the usage monitoring key. In 12.0 and later releases, usage reporting on last rule deactivation using rule deactivation time set by PCRF is supported.

Releases prior to 14.0, when PCC rule was tried to be removed while waiting for access side update bearer response, the charging rules were not removed. In 14.0 and later releases, on receiving message from PCRF, the rule that is meant for removal is marked and then after the access side procedure is complete the rule is removed.

- **PCRF Requested Usage Report:** In 10.2 and later releases, the accumulated usage since the last report is sent even in case of immediate reporting, the usage is reset after immediate reporting and usage monitoring continued so that the subsequent usage report will have the usage since the current report. In earlier releases the behavior was to accumulate the so far usage in the next report.
- **Release 12.2 onwards,** usage reporting on bearer termination can be added. When a bearer is deleted due to some reason, the rules associated with the bearer will also be removed. So, the usage will be reported on the monitoring key(s) whose associated rule is the last one that is removed because of bearer termination.
- **Revalidation Timeout:** In the non-standard implementation, if usage monitoring and reporting is enabled and a revalidation timeout occurs, the PCEF sends a CCR to request PCC rules and reports all accumulated usage for all enabled monitoring keys since the last report (or since usage reporting was enabled if the usage was not yet reported) with the accumulated usage at IP-CAN session level (if enabled) and at service data flow level (if enabled) This is the default behavior.

In the case of standard implementation, this must be enabled by CLI configuration.



Important

The Usage Reporting on Revalidation Timeout feature is available by default in non-standard implementation of Volume Reporting over Gx. In 10.2 and later releases, this is configurable in the standard implementation. This is not supported in 10.0 release for standard based volume reporting.

Once the usage is reported, the usage counter is reset to zero. The PCEF continues to track data usage from the zero value after the threshold is reached and before a new threshold is provided by the PCRF. If a new usage threshold is not provided by the PCRF in the acknowledgement of an IP-CAN Session modification where its usage was reported, then usage monitoring does not continue in the PCEF for that IP CAN session and the usage accumulated between the CCR-CCA will be discarded.

In releases prior to 17.0, CCR-U triggered on server retries does not take server granted quota into account for reporting USU. In 17.0 and later releases, CCR-U triggered on server retries takes server granted quota into account for reporting USU. For newly created MSCC, interim quota configuration is taken as reference for reporting USU.

For information on how to configure the Volume Reporting over Gx feature, refer to [Configuring Volume Reporting over Gx](#), on page 233.

ICSR Support for Volume Reporting over Gx (VoRoGx)

In releases prior to 15.0, post the ICSR switchover, any existing session for which the PCRF has enabled volume reporting used to continue indefinitely until the session is terminated or until CCR-U is sent for a given trigger, without having the volume counted via Gx.

To summarize, after an ICSR switchover, volume reporting over Gx is no longer done for existing sessions. Also, volume usage is not synced to standby chassis.

In 15.0 and later releases, volume threshold and volume usage are synced to standby chassis to support volume reporting over Gx for existing sessions post switchover.

Without this support it cannot cause a subscriber to use higher speeds than what s/he is supposed to get, if volume reporting is for example used to enforce fair usage; the operator may already consider this a revenue loss. It will also severely impact roaming subscribers who are supposed to get a notification and be blocked/redirected once the limits set by the EU roaming regulation are reached. If a session continues now without being blocked, the operator is not allowed to charge for data beyond the limit and will have a significant and real revenue loss (roaming partner may still charge for the data used on their SGSNs).

Rel. 9 Gx Interface

Rel. 9 Gx interface support is available on the Cisco ASR chassis running StarOS 12.2 and later releases.

P-GW Rel. 9 Gx Interface Support

Introduction

The Gx reference point is located between the Policy and Charging Rules Function (PCRF) and the Policy and Charging Enforcement Function (PCEF) on the Packet Data Network (PDN) Gateway (P-GW). The Gx reference point is used for provisioning and removal of PCC rules from the PCRF to the PCEF and the transmission of traffic plane events from the PCEF to the PCRF. The Gx reference point can be used for charging control, policy control, or both, by applying AVPs relevant to the application.

The PCEF is the functional element that encompasses policy enforcement and flow based charging functionality. This functional entity is located at the P-GW. The main functions include:

- Control over the user plane traffic handling at the gateway and its QoS.
- Service data flow detection and counting, as well as online and offline charging interactions.
- For a service data flow that is under policy control, the PCEF allows the service data flow to pass through the gateway if and only if the corresponding gate is open.
- For a service data flow that is under charging control, the PCEF allows the service data flow to pass through the gateway if and only if there is a corresponding active PCC rule and, for online charging, the OCS has authorized the applicable credit with that charging key.

- If requested by the PCRF, the PCEF reports to the PCRF when the status of the related service data flow changes.
- In case the SDF is tunnelled at the BBERF, the PCEF informs the PCRF about the mobility protocol tunnelling header of the service data flows at IP-CAN session establishment.



Important ASR 5500 supports only eight flow information including the flow description per dynamic charging rule in a Gx message.

Terminology and Definitions

This section describes features and terminology pertaining to Rel. 9 Gx functionality.

Volume Reporting Over Gx

This section describes the 3GPP Rel. 9 Volume Reporting over Gx feature.

License Requirements

The Volume Reporting over Gx is a licensed Cisco feature. A separate feature license may be required. Contact your Cisco account representative for detailed information on specific licensing requirements. For information on installing and verifying licenses, refer to the *Managing License Keys* section of the *Software Management Operations* chapter in the *System Administration Guide*.



Important In 12.0 and later releases, no separate license is required for Charging over Gx / Volume Reporting over Gx feature. This feature can be enabled as part of "Policy Interface" license.

Supported Standards

The Volume Reporting over Gx feature is based on the following standard:

3GPP TS 29.212 V9.5.0 (2011-01): 3rd Generation Partnership Project; Technical Specification Group Core Network and Terminals; Policy and Charging Control over Gx reference point (Release 9).

Feature Overview

The Volume Reporting over Gx feature provides PCRF the capability to make real-time decisions based on the data usage by subscribers.



Important Volume Reporting over Gx is applicable only for volume quota.

In release 10.0, only total data usage reporting is supported, uplink/downlink level reporting is not supported. In 10.2 and later releases, it is supported.

In release 10.0, only total data usage reporting is supported, uplink/downlink level reporting is not supported. In 10.2 and later releases, it is supported.

The PCEF only reports the accumulated usage since the last report for usage monitoring and not from the beginning.

If the usage threshold is set to zero (infinite threshold), no further threshold events will be generated by PCEF, but monitoring of usage will continue and be reported at the end of the session.

In 12.2 and later releases, usage reporting on bearer termination is supported.

The following steps explain how Volume Reporting over Gx works:

1. PCEF after receiving the message from PCRF parses the usage monitoring related AVPs, and sends the information to IMSA.
2. IMSA updates the information to ECS.
3. Once the ECS is updated with the usage monitoring information from PCRF, the PCEF (ECS) starts tracking the data usage.
4. For session-level monitoring, the ECS maintains the amount of data usage.
5. For PCC rule monitoring, usage is monitored with the monitoring key as the unique identifier. Each node maintains the usage information per monitoring key. When the data traffic is passed, the usage is checked against the usage threshold values and reported as described in the *Usage Reporting* section.
6. The PCEF continues to track data usage after the threshold is reached and before a new threshold is provided by the PCRF. If a new usage threshold is not provided by the PCRF in the acknowledgement of an IP-CAN Session modification where its usage was reported, then usage monitoring does not continue in the PCEF for that IP CAN session.

Usage Monitoring

- Usage Monitoring at Session Level: PCRF subscribes to the session-level volume reporting over Gx by sending the Usage-Monitoring-Information AVP with the usage threshold level set in Granted-Service-Unit AVP and Usage-Monitoring-Level AVP set to SESSION_LEVEL(0). After the AVPs are parsed by DPCA, IMSA updates the information to ECS. Once ECS is updated usage monitoring is started and constantly checked with the usage threshold whenever the data traffic is present. In 11.0 and later releases, Monitoring Key at session level is supported.

In 12.0 and later releases, enabling and disabling session usage in a single message from PCRF is supported. This is supported only if the monitoring key is associated at session level.

In 12.0 and later releases, monitoring of usage based on input/output octet threshold levels is supported. Usage is reported based on the enabled threshold level. If multiple levels are enabled, usage will be reported on all the enabled levels even if only one of the levels is breached. Monitoring will be stopped on the missing threshold levels in the response for the usage report from PCRF (expected to provide the complete set again if PCRF wants to continue monitoring on the multiple levels enabled earlier).

Total threshold level along with UL/DL threshold level in the GSU AVP is treated as an error and only total threshold level is accepted.

In releases prior to 17.0, extra CCR-U was generated for a monitoring key when the following requests are received in the response to the CCR-U which reported the usage for the same monitoring key.

- immediate reporting request with monitoring key at rule level
- immediate reporting request with or without monitoring key at session level
- explicit disable request at rule level
- explicit disable request at session level

In 17.0 and later releases, extra CCR-U is not generated for a monitoring key when all the above mentioned requests are received in the response to the CCR-U which reported the usage for the same monitoring key. Also, extra CCR-U is not generated when immediate reporting request without monitoring key at rule level is received in the response to the CCR-U which reported the usage for all the active monitoring keys.

- **Usage Monitoring at Flow Level:** PCRF subscribes to the flow-level volume reporting over Gx by sending the Usage-Monitoring-Information AVP with the usage threshold level set in Granted-Service-Unit AVP and Usage-Monitoring-Level AVP set to PCC_RULE_LEVEL(1). Monitoring Key is mandatory in case of a flow-level monitoring since the rules are associated with the monitoring key and enabling/disabling of usage monitoring at flow level can be controlled by PCRF using it. After the AVPs are parsed by DPCA, IMSA updates the information to ECS. Once ECS is updated usage monitoring is started and constantly checked with the usage threshold whenever the data traffic is present.

Usage monitoring is supported for static, predefined rules, and dynamic rule definitions.

- **Usage Monitoring for Static Rules:** In the case of static rules, the usage reporting on last rule removal associated with the monitoring key is not applicable. In this case only the usage monitoring information is received from the PCRF.
- **Usage Monitoring for Predefined Rules:** If the usage monitoring needs to be enabled for the predefined rules, PCRF sends the rule and the usage monitoring information containing the monitoring key and the usage threshold. The Monitoring key should be same as the one pre-configured in PCEF for that predefined rule. There can be multiple rules associated with the same monitoring key. Hence enabling a particular monitoring key would result in the data being tracked for multiple rules having the same monitoring key. After DPCA parses the AVPs IMSA updates the information to ECS. Once ECS is updated usage monitoring is started and constantly checked with the usage threshold whenever the data traffic is present.
- **Usage Monitoring for Dynamic Rules:** If the usage monitoring needs to be enabled for dynamic ruledefs, PCRF provides the monitoring key along with a charging rule definition and the usage monitoring information containing the monitoring key and the usage threshold. This would result in the usage monitoring being done for all the rules associated with that monitoring key. After DPCA parses the AVPs, IMSA updates the information to ECS. Once ECS is updated, the usage monitoring is started and constantly checked with the usage threshold whenever the data traffic is present. Monitoring key for dynamic ruledef is dynamically assigned by PCRF which is the only difference with predefined rules in case of usage monitoring.

In releases prior to 15.0, when threshold breach happens for multiple monitoring keys at the same time, only one of the monitoring keys' usage is reported and the rest of the monitoring keys' usage is reported in CCR-T (threshold set to infinity). On Tx expiry/TCP link error, unreported usage is stored at ECS and reported only on session termination.

In 15.0 and later releases, only one of the monitoring keys' usage is reported first. Upon receiving successful response from PCRF, the rest of the monitoring keys' usage is reported to PCRF. On Tx expiry/TCP link error, unreported usage is stored at ECS. Any future successful interaction with PCRF for the session will send unreported UMI to PCRF.

Usage Reporting

Usage at subscriber/flow level is reported to PCRF under the following conditions:

- **Usage Threshold Reached:** PCEF records the subscriber data usage and checks if the usage threshold provided by PCRF is reached. This is done for both session and rule level reporting.

For session-level reporting, the actual usage volume is compared with the usage volume threshold.

For rule-level reporting the rule that hits the data traffic is used to find out if the monitoring key is associated with it, and based on the monitoring key the data usage is checked. Once the condition is met, it reports the usage information to IMSA and continues monitoring. IMSA then triggers the CCR-U if "USAGE_REPORT" trigger is enabled by the PCRF. The Usage-Monitoring-Information AVP is sent in this CCR with the "Used-Service-Unit" set to the amount of data usage by subscriber.

If PCRF does not provide a new usage threshold in the usage monitoring information as a result of CCR from PCEF when the usage threshold is reached, the usage monitoring is stopped at PCEF and no usage status is reported.

In the non-standard Volume Reporting over Gx implementation, usage monitoring will be stopped once the threshold is breached, else the monitoring will continue. There will be no further usage reporting until the CCA is received.

- **Usage Monitoring Disabled:** If the PCRF explicitly disables the usage monitoring with Usage-Monitoring-Support AVP set to USAGE_MONITORING_DISABLED, the PCEF stops monitoring and reports the usage information (when the monitoring was enabled) to PCRF if the usage monitoring is disabled by PCRF as a result of CCR from PCEF which is not related to reporting usage, other external triggers, or a PCRF internal trigger. If the PCRF does not provide a new usage threshold as a result of CCR from PCEF when the usage threshold is reached, the usage monitoring is stopped at PCEF and no further usage status is reported.
- **IP CAN Session Termination:** When the IP CAN session is terminated, the accumulated subscriber usage information is reported to PCRF in the CCR-T from PCEF. If PCC usage level information is enabled by PCRF, the PCC usage will also be reported.

PCRF uses RAR message and includes Session-Release-Cause AVP in it to initiate IP CAN Session Termination. However, there are some scenarios where PCRF may want to terminate the IP CAN Session in CCA messages. In order to avoid an unnecessary additional message, PCRF can inform P-GW to terminate the subscriber in CCA-U message itself. Hence, in 17.0 and later releases, the Session Release Cause has been added in CCA messages for all Gx dictionaries.

- **PCC Rule Removal:** When the PCRF deactivates the last PCC rule associated with a usage monitoring key, the PCEF sends a CCR with the data usage for that monitoring key. If the PCEF reports the last PCC rule associated with a usage monitoring key is inactive, the PCEF reports the accumulated usage for that monitoring key within the same CCR command if the Charging-Rule-Report AVP was included in a CCR command; otherwise, if the Charging-Rule-Report AVP was included in an RAA command, the PCEF sends a new CCR command to report accumulated usage for the usage monitoring key. In 12.0 and later releases, usage reporting on last rule deactivation using rule deactivation time set by PCRF is supported.

Releases prior to 14.0, when PCC rule was tried to be removed while waiting for access side update bearer response, the charging rules were not removed. In 14.0 and later releases, on receiving message from PCRF, the rule that is meant for removal is marked and then after the access side procedure is complete the rule is removed.

- **PCRF Requested Usage Report:** In 10.2 and later releases, the accumulated usage since the last report is sent even in case of immediate reporting, the usage is reset after immediate reporting and usage monitoring continued so that the subsequent usage report will have the usage since the current report. In earlier releases the behavior was to accumulate the so far usage in the next report.
- **Release 12.2 onwards,** usage reporting on bearer termination can be added. When a bearer is deleted due to some reason, the rules associated with the bearer will also be removed. So, the usage will be reported on the monitoring key(s) whose associated rule is the last one that is removed because of bearer termination.
- **Revalidation Timeout:** In the non-standard implementation, if usage monitoring and reporting is enabled and a revalidation timeout occurs, the PCEF sends a CCR to request PCC rules and reports all accumulated usage for all enabled monitoring keys since the last report (or since usage reporting was enabled if the usage was not yet reported) with the accumulated usage at IP-CAN session level (if enabled) and at service data flow level (if enabled) This is the default behavior.

In the case of standard implementation, this must be enabled by CLI configuration.



Important

The Usage Reporting on Revalidation Timeout feature is available by default in non-standard implementation of Volume Reporting over Gx. In 10.2 and later releases, this is configurable in the standard implementation. This is not supported in 10.0 release for standard based volume reporting.

Once the usage is reported, the usage counter is reset to zero. The PCEF continues to track data usage from the zero value after the threshold is reached and before a new threshold is provided by the PCRF. If a new usage threshold is not provided by the PCRF in the acknowledgement of an IP-CAN Session modification where its usage was reported, then usage monitoring does not continue in the PCEF for that IP CAN session and the usage accumulated between the CCR-CCA will be discarded.

In releases prior to 17.0, CCR-U triggered on server retries does not take server granted quota into account for reporting USU. In 17.0 and later releases, CCR-U triggered on server retries takes server granted quota into account for reporting USU. For newly created MSCC, interim quota configuration is taken as reference for reporting USU.

For information on how to configure the Volume Reporting over Gx feature, see the [Configuring Volume Reporting over Gx, on page 233](#) section.

ICSR Support for Volume Reporting over Gx (VoRoGx)

In releases prior to 15.0, post the ICSR switchover, any existing session for which the PCRF has enabled volume reporting used to continue indefinitely until the session is terminated or until CCR-U is sent for a given trigger, without having the volume counted via Gx.

To summarize, after an ICSR switchover, volume reporting over Gx is no longer done for existing sessions. Also, volume usage is not synced to standby chassis.

In 15.0 and later releases, volume threshold and volume usage are synced to standby chassis to support volume reporting over Gx for existing sessions post switchover.

Without this support it cannot cause a subscriber to use higher speeds than what s/he is supposed to get, if volume reporting is for example used to enforce fair usage; the operator may already consider this a revenue loss. It will also severely impact roaming subscribers who are supposed to get a notification and be blocked/redirected once the limits set by the EU roaming regulation are reached. If a session continues now without being blocked, the operator is not allowed to charge for data beyond the limit and will have a significant and real revenue loss (roaming partner may still charge for the data used on their SGSNs).

3GPP Rel.9 Compliance for IPFilterRule

This section describes the overview and implementation of 3GPP Rel.9 Compliance for IPFilterRule feature.

This section discusses the following topics for this feature:

- [Feature Description, on page 263](#)
- [Configuring Rel.9 Compliant AVPs, on page 264](#)
- [Monitoring and Troubleshooting the 3GPP Rel.9 Compliance for IPFilterRule, on page 265](#)

Feature Description

Currently, PCEF is 3GPP Rel. 8 compliant for IPFilterRule in Flow-Description AVP, TFT-Filter, and Packet-Filter-Content AVPs. When PCRF sends the CCA-U or RAR with Flow-Description AVP in Rel. 9 format during a network initiated dedicated bearer creation or modification, PCEF was misinterpreting the source and destination IP address, resulting in sending a wrong TFT to UE.

When the PCRF is upgraded to 3GPP Rel. 9, PCEF still sends CCR-U with Flow-Description, TFT-Filter and Packet-Filter-Content AVPs in Rel. 8 format during UE initiated secondary bearer creation or modification.

To make the PCEF 3GPP Rel. 9 compliant for Flow-Description AVP, TFT-Filter, and Packet-Filter-Content AVPs, the following changes are implemented:

- Interpretation of the source and destination IP address in IPFilterRule in Flow-Description AVP is changed to maintain 3GPP Rel.9 compliancy. That is, when a Rel. 9 Flow-Description for UPLINK is received during a network-initiated bearer creation or modification, the source IP address is interpreted as remote and the destination as local IP address.
- Traffic flow direction is interpreted from a new Diameter AVP "Flow-Direction". This new AVP indicates the direction or directions that a filter is applicable, downlink only, uplink only or both downlink and uplink (bi-directional).
- IMSA module is modified to encode TFT-Packet-Filter-Information and Packet-Filter-Information AVPs in Rel. 9 format if the negotiated supported feature is Rel. 9 and above.
- Configuration support is provided to enable Rel.9 changes for Flow-Description, TFT-Filter, and Packet-Filter-Content AVPs sent by PCEF in CCR-U. The **diameter 3gpp-r9-flow-direction** CLI command is used to enable Rel. 9 changes. When this CLI command is configured and negotiated supported feature is Rel. 9 or above (both gateway and PCRF are Rel. 9+ compliant), P-GW sends Flow-Description, TFT-Filter, and Packet-Filter-Content AVPs in Rel. 9 format.

Backward compatibility is maintained, i.e. both Rel. 8 (permit in/out) and Rel. 9 (permit out with flow-direction) formats are accepted by PCEF.

Per the 3GPP Rel. 8 standards, the IPFilterRule in Flow-Description, TFT-Filter, and Packet-Filter-Content AVPs is sent as "permit in" for UPLINK and "permit out" for DOWNLINK direction. From 3GPP Rel. 9 onwards, the Flow-Description AVP within the Flow-Information AVP will have only "permit out" and the

traffic flow direction is indicated through Flow-Direction AVP. In 3GPP Rel. 9 format, both UPLINK and DOWNLINK are always sent as "permit out" and hence the usage of "permit in" is deprecated.



Important This feature is applicable for 3GPP Rel. 9 compliant PCEF and PCRF only when the supported feature negotiated in CCA-I is Rel. 9 or above through the **diameter update-dictionary-avps { 3gpp-r9 | 3gpp-r10 }** CLI command.

Relationships to Other Features

This feature works only when the **diameter update-dictionary-avps** CLI command is configured as 3gpp-r9 or 3gpp-r10. That is, PCEF will send Flow-Description, TFT-Filter, and Packet-Filter-Content AVPs in 3GPP Rel. 9 format only when **diameter 3gpp-r9-flow-direction** CLI command is enabled and negotiated supported feature is Rel. 9 or above. The **diameter 3gpp-r9-flow-direction** CLI command for activating this feature must be used only after the PCRF is upgraded to Rel. 9.

Configuring Rel.9 Compliant AVPs

The following section provides the configuration commands to enable Rel.9 changes for Flow-Description, TFT-Filter, and Packet-Filter-Content AVPs.

Encoding AVPs for 3GPP Compliance

Use the following configuration commands to control PCEF from sending Flow-Description, TFT-Filter, and Packet-Filter-Content AVPs in Rel. 9 format.

```
configure
  context context_name
    ims-auth-service service_name
      policy-control
        diameter 3gpp-r9-flow-direction
  end
```

- **3gpp-r9-flow-direction**: Encodes Flow-Direction, Flow-Description, TFT-Filter, and Packet-Filter-Content AVPs based on 3GPP Rel. 9 specification. By default, this feature is disabled.
- This CLI configuration is applicable only for TFT-Filter, Packet-Filter-Content, and Flow-Description AVPs sent by PCEF in CCR-U.
- This CLI command must be used only after the PCRF is upgraded to Rel. 9.
- This CLI command works in conjunction with **diameter update-dictionary-avps { 3gpp-r9 | 3gpp-r10 }**. When **diameter 3gpp-r9-flow-direction** is configured and negotiated supported feature is 3gpp-r9 or above, PCEF will send Flow-Description, TFT-Filter, and Packet-Filter-Content AVPs in 3GPP Rel. 9 format.

Verifying the Configuration for AVP Compliance

Use the following command to verify the configuration status of this feature.

```
show ims-authorization service name service_name
```

service_name must be the name of the IMS Authorization service configured for IMS authentication.

The "3GPP R9 Flow Direction Compliance" field can be used to determine whether this feature is enabled or disabled.

```
[local]st40# show ims-authorization service name gngp-gx
Context: gngp
IMS Authorization Service name: gngp-gx
Service State: Enabled
Service Mode: Single Interface Policy and Charging
...
Diameter Policy Control:
Endpoint: gx
Origin-Realm: xyz.com
Dictionary: r8-gx-standard
Supported Features:
    3gpp-r9
...
Host Selection: Table: 1 Algorithm: Round-Robin
Host Reselection Subscriber Limit: Not Enabled
Host Reselection Interval: Not Enabled
Sgsn Change Reporting: Not Enabled
    3GPP R9 Flow Direction Compliance: Enabled
Host Selection Table[1]: 1 Row(s)
Precedence: 1
...
```

Monitoring and Troubleshooting the 3GPP Rel.9 Compliance for IPFilterRule

This section provides information regarding show commands and/or their outputs in support of this feature.

The following operations should be performed for any failure related to this feature:

- Verify if the feature is enabled using **show ims-authorization service name** *<service_name>* CLI command. If not enabled, configure the **diameter 3gpp-r9-flow-direction** CLI command and check if it works.
- Execute **monitor protocol** command, and check if supported feature negotiated in CCA-I is Rel. 9 or above. If not, this feature will not work. Set the supported feature using **diameter update-dictionary-avps { 3gpp-r9 | 3gpp-r10 }** CLI command.
- If the failure is still observed, obtain the following information and contact Cisco account representative for further analysis:
 - monitor protocol log with options 24 (GTPC) and 75-3 (App Specific Diameter - DIAMETER Gx/Ty/Gxx) turned on
 - logs with acsmgr enabled
 - Output of **show active-charging sessions full all** and show ims-authorization sessions CLI commands

show ims-authorization service name

A new field "3GPP R9 Flow Direction Compliance" is added to the output of this show command to indicate whether the Rel. 9 Flow-Direction change is enabled or disabled.

Rel. 10 Gx Interface

Rel. 10 Gx interface support is available on the Cisco ASR chassis running StarOS 15.0 and later releases.

This section describes the following topic:

- [P-GW Rel. 10 Gx Interface Support, on page 266](#)

P-GW Rel. 10 Gx Interface Support

Introduction

The Gx reference point is located between the Policy and Charging Rules Function (PCRF) and the Policy and Charging Enforcement Function (PCEF) on the Packet Data Network (PDN) Gateway (P-GW). The Gx reference point is used for provisioning and removal of PCC rules from the PCRF to the PCEF and the transmission of traffic plane events from the PCEF to the PCRF. The Gx reference point can be used for charging control, policy control, or both, by applying AVPs relevant to the application.

The PCEF is the functional element that encompasses policy enforcement and flow based charging functionality. This functional entity is located at the P-GW. The main functions include:

- Control over the user plane traffic handling at the gateway and its QoS.
- Service data flow detection and counting, as well as online and offline charging interactions.
- For a service data flow that is under policy control, the PCEF allows the service data flow to pass through the gateway if and only if the corresponding gate is open.
- For a service data flow that is under charging control, the PCEF allows the service data flow to pass through the gateway if and only if there is a corresponding active PCC rule and, for online charging, the OCS has authorized the applicable credit with that charging key.
- If requested by the PCRF, the PCEF will report to the PCRF when the status of the related service data flow changes.
- In case the SDF is tunnelled at the BBERF, the PCEF informs the PCRF about the mobility protocol tunnelling header of the service data flows at IP-CAN session establishment.



Important ASR 5500 supports only eight flow information including the flow description per dynamic charging rule in a Gx message.

Terminology and Definitions

This section describes features and terminology pertaining to Rel. 10 Gx functionality.

Volume Reporting Over Gx

This section describes the 3GPP Rel. 10 Volume Reporting over Gx feature.

License Requirements

The Volume Reporting over Gx is a licensed Cisco feature. A separate feature license may be required. Contact your Cisco account representative for detailed information on specific licensing requirements. For information on installing and verifying licenses, refer to the *Managing License Keys* section of the *Software Management Operations* chapter in the *System Administration Guide*.

**Important**

In 12.0 and later releases, no separate license is required for Charging over Gx / Volume Reporting over Gx feature. This feature can be enabled as part of "Policy Interface" license.

Supported Standards

The Volume Reporting over Gx feature is based on the following standard:

3GPP TS 29.212 V10.5.0 (2012-01): 3rd Generation Partnership Project; Technical Specification Group Core Network and Terminals; Policy and Charging Control over Gx reference point (Release 10).

Feature Overview

The Volume Reporting over Gx feature provides PCRF the capability to make real-time decisions based on the data usage by subscribers.

**Important**

Volume Reporting over Gx is applicable only for volume quota.

In release 10.0, only total data usage reporting is supported, uplink/downlink level reporting is not supported. In 10.2 and later releases, it is supported.

The PCEF only reports the accumulated usage since the last report for usage monitoring and not from the beginning.

If the usage threshold is set to zero (infinite threshold), no further threshold events will be generated by PCEF, but monitoring of usage will continue and be reported at the end of the session.

In 12.2 and later releases, usage reporting on bearer termination is supported.

The following steps explain how Volume Reporting over Gx works:

1. PCEF after receiving the message from PCRF parses the usage monitoring related AVPs, and sends the information to IMSA.
2. IMSA updates the information to ECS.
3. Once the ECS is updated with the usage monitoring information from PCRF, the PCEF (ECS) starts tracking the data usage.
4. For session-level monitoring, the ECS maintains the amount of data usage.
5. For PCC rule monitoring, usage is monitored with the monitoring key as the unique identifier. Each node maintains the usage information per monitoring key. When the data traffic is passed, the usage is checked against the usage threshold values and reported as described in the *Usage Reporting* section.
6. The PCEF continues to track data usage after the threshold is reached and before a new threshold is provided by the PCRF. If a new usage threshold is not provided by the PCRF in the acknowledgement of an IP-CAN Session modification where its usage was reported, then usage monitoring does not continue in the PCEF for that IP CAN session.

Usage Monitoring

- Usage Monitoring at Session Level: PCRF subscribes to the session-level volume reporting over Gx by sending the Usage-Monitoring-Information AVP with the usage threshold level set in Granted-Service-Unit

AVP and Usage-Monitoring-Level AVP set to SESSION_LEVEL(0). After the AVPs are parsed by DPCA, IMSA updates the information to ECS. Once ECS is updated usage monitoring is started and constantly checked with the usage threshold whenever the data traffic is present. In 11.0 and later releases, Monitoring Key at session level is supported.

In 12.0 and later releases, enabling and disabling session usage in a single message from PCRF is supported. This is supported only if the monitoring key is associated at session level.

In 12.0 and later releases, monitoring of usage based on input/output octet threshold levels is supported. Usage is reported based on the enabled threshold level. If multiple levels are enabled, usage will be reported on all the enabled levels even if only one of the levels is breached. Monitoring will be stopped on the missing threshold levels in the response for the usage report from PCRF (expected to provide the complete set again if PCRF wants to continue monitoring on the multiple levels enabled earlier).

Total threshold level along with UL/DL threshold level in the GSU AVP is treated as an error and only total threshold level is accepted.

In releases prior to 17.0, extra CCR-U was generated for a monitoring key when the following requests are received in the response to the CCR-U which reported the usage for the same monitoring key.

- immediate reporting request with monitoring key at rule level
- immediate reporting request with or without monitoring key at session level
- explicit disable request at rule level
- explicit disable request at session level

In 17.0 and later releases, extra CCR-U is not generated for a monitoring key when all the above mentioned requests are received in the response to the CCR-U which reported the usage for the same monitoring key. Also, extra CCR-U is not generated when immediate reporting request without monitoring key at rule level is received in the response to the CCR-U which reported the usage for all the active monitoring keys.

- Usage Monitoring at Flow Level: PCRF subscribes to the flow-level volume reporting over Gx by sending the Usage-Monitoring-Information AVP with the usage threshold level set in Granted-Service-Unit AVP and Usage-Monitoring-Level AVP set to PCC_RULE_LEVEL(1). Monitoring Key is mandatory in case of a flow-level monitoring since the rules are associated with the monitoring key and enabling/disabling of usage monitoring at flow level can be controlled by PCRF using it. After the AVPs are parsed by DPCA, IMSA updates the information to ECS. Once ECS is updated usage monitoring is started and constantly checked with the usage threshold whenever the data traffic is present.

Usage monitoring is supported for static, predefined rules, and dynamic rule definitions.

- Usage Monitoring for Static Rules: In the case of static rules, the usage reporting on last rule removal associated with the monitoring key is not applicable. In this case only the usage monitoring information is received from the PCRF.
- Usage Monitoring for Predefined Rules: If the usage monitoring needs to be enabled for the predefined rules, PCRF sends the rule and the usage monitoring information containing the monitoring key and the usage threshold. The Monitoring key should be same as the one pre-configured in PCEF for that predefined rule. There can be multiple rules associated with the same monitoring key. Hence enabling a particular monitoring key would result in the data being tracked for multiple rules having the same monitoring key. After DPCA parses the AVPs IMSA updates the information to ECS. Once ECS is updated usage monitoring is started and constantly checked with the usage threshold whenever the data traffic is present.
- Usage Monitoring for Dynamic Rules: If the usage monitoring needs to be enabled for dynamic ruledefs, PCRF provides the monitoring key along with a charging rule definition and the usage

monitoring information containing the monitoring key and the usage threshold. This would result in the usage monitoring being done for all the rules associated with that monitoring key. After DPCA parses the AVPs, IMSA updates the information to ECS. Once ECS is updated, the usage monitoring is started and constantly checked with the usage threshold whenever the data traffic is present. Monitoring key for dynamic ruledef is dynamically assigned by PCRF which is the only difference with predefined rules in case of usage monitoring.

In releases prior to 15.0, when threshold breach happens for multiple monitoring keys at the same time, only one of the monitoring keys' usage is reported and the rest of the monitoring keys' usage is reported in CCR-T (threshold set to infinity). On Tx expiry/TCP link error, unreported usage is stored at ECS and reported only on session termination.

In 15.0 and later releases, only one of the monitoring keys' usage is reported first. Upon receiving successful response from PCRF, the rest of the monitoring keys' usage is reported to PCRF. On Tx expiry/TCP link error, unreported usage is stored at ECS. Any future successful interaction with PCRF for the session will send unreported UMI to PCRF.

Usage Reporting

Usage at subscriber/flow level is reported to PCRF under the following conditions:

- **Usage Threshold Reached:** PCEF records the subscriber data usage and checks if the usage threshold provided by PCRF is reached. This is done for both session and rule level reporting.

For session-level reporting, the actual usage volume is compared with the usage volume threshold.

For rule-level reporting the rule that hits the data traffic is used to find out if the monitoring key is associated with it, and based on the monitoring key the data usage is checked. Once the condition is met, it reports the usage information to IMSA and continues monitoring. IMSA then triggers the CCR-U if "USAGE_REPORT" trigger is enabled by the PCRF. The Usage-Monitoring-Information AVP is sent in this CCR with the "Used-Service-Unit" set to the amount of data usage by subscriber.

If PCRF does not provide a new usage threshold in the usage monitoring information as a result of CCR from PCEF when the usage threshold is reached, the usage monitoring is stopped at PCEF and no usage status is reported.

In the non-standard Volume Reporting over Gx implementation, usage monitoring will be stopped once the threshold is breached, else the monitoring will continue. There will be no further usage reporting until the CCA is received.

- **Usage Monitoring Disabled:** If the PCRF explicitly disables the usage monitoring with Usage-Monitoring-Support AVP set to USAGE_MONITORING_DISABLED, the PCEF stops monitoring and reports the usage information (when the monitoring was enabled) to PCRF if the usage monitoring is disabled by PCRF as a result of CCR from PCEF which is not related to reporting usage, other external triggers, or a PCRF internal trigger. If the PCRF does not provide a new usage threshold as a result of CCR from PCEF when the usage threshold is reached, the usage monitoring is stopped at PCEF and no further usage status is reported.
- **IP CAN Session Termination:** When the IP CAN session is terminated, the accumulated subscriber usage information is reported to PCRF in the CCR-T from PCEF. If PCC usage level information is enabled by PCRF, the PCC usage will also be reported.

PCRF uses RAR message and includes Session-Release-Cause AVP in it to initiate IP CAN Session Termination. However, there are some scenarios where PCRF may want to terminate the IP CAN Session in CCA messages. In order to avoid an unnecessary additional message, PCRF can inform P-GW to

terminate the subscriber in CCA-U message itself. Hence, in 17.0 and later releases, the Session Release Cause has been added in CCA messages for all Gx dictionaries.

- **PCC Rule Removal:** When the PCRF deactivates the last PCC rule associated with a usage monitoring key, the PCEF sends a CCR with the data usage for that monitoring key. If the PCEF reports the last PCC rule associated with a usage monitoring key is inactive, the PCEF reports the accumulated usage for that monitoring key within the same CCR command if the Charging-Rule-Report AVP was included in a CCR command; otherwise, if the Charging-Rule-Report AVP was included in an RAA command, the PCEF sends a new CCR command to report accumulated usage for the usage monitoring key. In 12.0 and later releases, usage reporting on last rule deactivation using rule deactivation time set by PCRF is supported.

Releases prior to 14.0, when PCC rule was tried to be removed while waiting for access side update bearer response, the charging rules were not removed. In 14.0 and later releases, on receiving message from PCRF, the rule that is meant for removal is marked and then after the access side procedure is complete the rule is removed.

- **PCRF Requested Usage Report:** In 10.2 and later releases, the accumulated usage since the last report is sent even in case of immediate reporting, the usage is reset after immediate reporting and usage monitoring continued so that the subsequent usage report will have the usage since the current report. In earlier releases the behavior was to accumulate the so far usage in the next report.
- **Release 12.2 onwards,** usage reporting on bearer termination can be added. When a bearer is deleted due to some reason, the rules associated with the bearer will also be removed. So, the usage will be reported on the monitoring key(s) whose associated rule is the last one that is removed because of bearer termination.
- **Revalidation Timeout:** In the non-standard implementation, if usage monitoring and reporting is enabled and a revalidation timeout occurs, the PCEF sends a CCR to request PCC rules and reports all accumulated usage for all enabled monitoring keys since the last report (or since usage reporting was enabled if the usage was not yet reported) with the accumulated usage at IP-CAN session level (if enabled) and at service data flow level (if enabled) This is the default behavior.

In the case of standard implementation, this must be enabled by CLI configuration.



Important

The Usage Reporting on Revalidation Timeout feature is available by default in non-standard implementation of Volume Reporting over Gx. In 10.2 and later releases, this is configurable in the standard implementation. This is not supported in 10.0 release for standard based volume reporting.

Once the usage is reported, the usage counter is reset to zero. The PCEF continues to track data usage from the zero value after the threshold is reached and before a new threshold is provided by the PCRF. If a new usage threshold is not provided by the PCRF in the acknowledgement of an IP-CAN Session modification where its usage was reported, then usage monitoring does not continue in the PCEF for that IP CAN session and the usage accumulated between the CCR-CCA will be discarded.

In releases prior to 17.0, CCR-U triggered on server retries does not take server granted quota into account for reporting USU. In 17.0 and later releases, CCR-U triggered on server retries takes server granted quota into account for reporting USU. For newly created MSCC, interim quota configuration is taken as reference for reporting USU.

For information on how to configure the Volume Reporting over Gx feature, refer to [Configuring Volume Reporting over Gx, on page 233](#).

ICSR Support for Volume Reporting over Gx (VoRoGx)

In releases prior to 15.0, post the ICSR switchover, any existing session for which the PCRF has enabled volume reporting used to continue indefinitely until the session is terminated or until CCR-U is sent for a given trigger, without having the volume counted via Gx.

To summarize, after an ICSR switchover, volume reporting over Gx is no longer done for existing sessions. Also, volume usage is not synced to standby chassis.

In 15.0 and later releases, volume threshold and volume usage are synced to standby chassis to support volume reporting over Gx for existing sessions post switchover.

Without this support it cannot cause a subscriber to use higher speeds than what s/he is supposed to get, if volume reporting is for example used to enforce fair usage; the operator may already consider this a revenue loss. It will also severely impact roaming subscribers who are supposed to get a notification and be blocked/redirected once the limits set by the EU roaming regulation are reached. If a session continues now without being blocked, the operator is not allowed to charge for data beyond the limit and will have a significant and real revenue loss (roaming partner may still charge for the data used on their SGSNs).

Use of the Supported-Features AVP on the Gx Interface

The Supported-Features AVP is used during session establishment to inform the destination host about the required and optional features that the origin host supports. The client will, in the first request in a Diameter session indicate the set of features required for the successful processing of the session. If there are features supported by the client that are not advertised as part of the required set of features, the client will provide in the same request this set of optional features that are optional for the successful processing of the session. The server will, in the first answer within the Diameter session indicate the set of features that it has in common with the client and that the server will support within the same Diameter session. Any further command messages will always be compliant with the list of supported features indicated in the Supported-Features AVPs and features that are not indicated in the Supported-Features AVPs during session establishment. Features that are not advertised as supported will not be used to construct the command messages for that Diameter session. Unless otherwise stated, the use of the Supported-Features AVP on the Gx reference point will be compliant with the requirements for dynamic discovery of supported features and associated error handling.

The base functionality for the Gx reference point is the 3GPP Rel. 7 standard and a feature is an extension to that functionality. If the origin host does not support any features beyond the base functionality, the Supported-Features AVP may be absent from the Gx commands. As defined in 3GPP TS 29.229, when extending the application by adding new AVPs for a feature, the new AVPs will have the M bit cleared and the AVP will not be defined mandatory in the command ABNF.

The Supported-Features AVP is of type grouped and contains the Vendor-Id, Feature-List-ID and Feature-List AVPs. On the Gx reference point, the Supported-Features AVP is used to identify features that have been defined by 3GPP and hence, the Vendor-Id AVP will contain the vendor ID of 3GPP (10415). If there are multiple feature lists defined for the Gx reference point, the Feature-List-ID AVP will differentiate those lists from one another.

Feature bit	Feature	M/O	Description
0	Rel8	M	This feature indicates the support of base 3GPP Rel-8 Gx functionality, including the AVPs and corresponding procedures supported by the base 3GPP Rel-7 Gx standard, but excluding those features represented by separate feature bits.
1	Rel9	M	This feature indicates the support of base 3GPP Rel-9 Gx functionality, including the AVPs and corresponding procedures supported by the Rel8 feature bit, but excluding those features represented by separate feature bits.
3	Rel10	M	This feature indicates the support of base 3GPP Rel-10 Gx functionality, including the AVPs and corresponding procedures supported by the Rel8 and Rel9 feature bit, but excluding those features represented by separate feature bits.
4	SponsoredConnectivity	O	This feature indicates support for sponsored data connectivity feature. If the PCEF supports this feature, the PCRF may authorize sponsored data connectivity to the subscriber.

In releases prior to 15.0, the Supported-Features AVP was not encoded in CCR-U messages, but it was supported only in CCR-I message. If Rel. 8 dictionary or any dictionary beyond Rel. 8 is used and PCRF does not provide Supported-Features AVP in CCA-I, then the call gets dropped.

In 15.0 and later releases, if PCEF configures Diameter dictionary as release 8, 9 or 10, then PCRF sends Supported-Features AVP so that PCEF will know what feature PCRF supports. If PCEF receives supported features lesser than or greater than requested features then supported feature will be mapped to the lower one.

Whenever the custom dictionary "dpca-custom24" is configured, the Supported-Features AVP including Vendor-Id AVP will be sent in all CCR messages.

Rule-Failure-Code AVP

The Rule-Failure-Code AVP indicates the reason that the QoS/PCC rules cannot be successfully installed/activated or enforced. The Rule-Failure-Code AVP is of type Enumerated. It is sent by the PCEF to the PCRF within a Charging-Rule-Report AVP to identify the reason a PCC Rule is being reported.

In releases prior to 15.0, only 11 rule failure codes were defined as the values for this AVP. In 15.0 and later releases, two new rule failure codes `INCORRECT_FLOW_INFORMATION` (12) and `NO_BEARER_BOUND` (15) are added. The name of the existing rule failure code 9 is changed to `MISSING_FLOW_INFORMATION`. For 3GPP Rel. 10, rule failure code 9 maps to `GW/PCEF_MALFUNCTION`.

Sponsored Data Connectivity

With Sponsored Data Connectivity, the sponsor has a business relationship with the operator and the sponsor reimburses the operator for the user's data connectivity in order to allow the user access to an associated Application Service Provider's (ASP) services. Alternatively, the user pays for the connectivity with a transaction which is separate from the subscriber's charging. It is assumed the user already has a subscription with the operator.

Sponsored Data Connectivity feature is introduced in Rel. 10 of 3GPP TS 29.212 specification. If Sponsored Data Connectivity is supported, the sponsor identity for a PCC rule identifies the 3rd party organization (the sponsor) who is willing to pay for the operator's charge for connectivity required to deliver a service to the end user.

The purpose of this feature is to identify the data consumption for a certain set of flows differently and charge it to sponsor. To support this, a new reporting level `"SPONSORED_CONNECTIVITY_LEVEL"` is added for reporting at Sponsor Connection level and two new AVPs `"Sponsor-Identity"` and `"Application-Service-Provider-Identity"` have been introduced at the rule level.

Sponsored Data Connectivity will be performed for service data flows associated with one or more PCC rules if the information about the sponsor, the application service provider and optionally the threshold values are provided by the Application Function (AF).

The provisioning of sponsored data connectivity per PCC rule will be performed using the PCC rule provisioning procedure. The sponsor identity will be set using the Sponsor-Identity AVP within the Charging-Rule-Definition AVP of the PCC rule. The application service provider identity will be set using the Application-Service-Provider-Identity AVP within the Charging-Rule-Definition AVP of the PCC rule. Sponsor-Identity AVP and Application-Service-Provider-Identity AVP will be included if the Reporting-Level AVP is set to the value `SPONSORED_CONNECTIVITY_LEVEL`.

When receiving the flow based usage thresholds from the AF, the PCRF will use the sponsor identity to generate a monitoring key. The PCRF may also request usage monitoring control, in this case, only the flow based usage is applied for the sponsored data connectivity. If requested, the PCEF may also report the usage to the PCRF.

A new CLI command **"diameter encode-supported-features"** has been added in Policy Control Configuration mode to send supported features with Sponsor Identity. For more information on the command, see the *Command Line Interface Reference*.

Sponsored connectivity feature will be supported only when both P-GW and PCRF support 3GPP Rel. 10. P-GW advertises release as a part of supported features in CCR-I to PCRF. If P-GW supports Release 10 and also sponsored connectivity but PCRF does not support it (as a part of supported features in CCA-I), this feature will be turned off.

This feature implementation impacts only the Gx dictionary "dpca-custom15". Also note that this feature is supported only for the dynamic rules.

Volume Reporting

For Volume Reporting over Gx, PCRF generates a unique monitoring key based on sponsor identity. Since flows with different monitoring keys are treated differently, flows with sponsor ID are charged differently.

Supported Gx Features

Assume Positive for Gx

In a scenario where both the primary and secondary PCRF servers are overloaded, the PCRF returns an error to P-GW and HSGW. Current behavior for the P-GW and HSGW is to terminate the session if both primary and secondary return a failure or timeout.

This feature is developed to enhance this behavior by applying local policy on the GW to ensure that the subscriber session continues. P-GW / HSGW should implement Assume Positive feature to handle errors and based on the event type implement specific rules.



Important

Use of Gx Assume Positive requires that a valid license key be installed. Contact your Cisco account representative for information on how to obtain a license.

The failure handling behavior is enhanced to ensure that the subscriber service is maintained in case of PCRF unavailability. It is also required that the GW reduces the traffic towards the PCRF when receiving a Diameter Too Busy (3004) by stopping the transmission and reception of Diameter messages (CCRs and RARs) to and from the PCRF for a configurable amount of time.

In case of any of the following failures with PCRF, the GW chooses to apply failure handling which results in subscriber termination or to allow browsing without any more policy enforcement.

- TCP link failure
- Application Timer (Tx) expiry
- Result code based failures

In 14.1 and later releases, the PCRF is allowed to fall back to Local Policy for all connection level failures, result code/experimental result code failures. Local Policy may choose to allow the subscriber for a configured amount of time. During this time any subscriber/internal event on the call would be handled from Local Policy. After the expiry of the timer, the subscriber session can be either terminated or else PCRF can be retried. Note that the retry attempt to PCRF happens only when the **timer-expiry event** is configured as **reconnect-to-server**.

The fallback support is added to the failure handling template and the local policy service needs to be associated to IMS Authorization service.

Once the local policy is applied, all PCRF enabled event triggers will be disabled. When the subscriber session is with the local-policy, the GW skips sending of CCR-T and cleans up the session locally.

For a session that was created with active Gx session, the GW sends the CCR-T to primary and on failure sends the CCR-T to the secondary PCRF. If the CCR-T returns a failure from both primary and secondary or times out, the GW cleans up the session locally.

Fallback to Local Policy is done in the following scenarios:

- Tx timer expiry
- Database Error

- Result Code Error (Permanent/Transient)
- Experimental Result Code
- Response Timeout

The following points are applicable only in the scenario where reconnect to PCRF is attempted.

- If the subscriber falls back to local-policy because of CCR-I failure, CCR-I will be sent to the PCRF after the timer expiry. On successful CCA-I call will be continued with PCRF or else the call will be continued with local-policy and retry-count will be incremented.
- If the subscriber falls back to local-policy because of the CCR-U failure, IMS Authorization application waits for some event change to happen or to receive an RAR from PCRF.
- In case of event change after the timer expiry, CCR-U will be sent to PCRF. On successful CCA-U message, call will be continued with PCRF or else call will be with local-policy and retry-count will be incremented.
- If RAR is received after the timer-expiry the call will be continued with the PCRF. On expiry of maximum of retries to connect to PCRF, call will be disconnected.

Default Policy on CCR-I Failure

The following parameters are supported for local configuration on P-GW. The configuration parameters are configurable per APN and per RAT Type.

The following fields for a Default Bearer Charging Rule are configurable per APN and per RAT Type:

- Rule Name
- Rating Group
- Service ID
- Online Charging
- Offline Charging
- QCI
- ARP
 - Priority Level
 - QCI
 - QVI
- Max-Requested-Bandwidth
 - UL
 - DL

Flow Description and Flow Status are not configurable but the default value will be set to Any to Any and Flow Status will be set to Enabled.

The following command level fields are configurable per APN and per RAT Type:

- AMBR
 - UL
 - DL
- QCI
- ARP

- Priority Level
- QCI
- QVI

Gx Back off Functionality

This scenario is applicable when Primary PCRF cluster is unavailable but the secondary PCRF is available to handle new CCR-I messages.

When the chassis receives 3004 result-code then back-off timer will be started for the peer and when the timer is running no messages will be sent to that peer.

The timer will be started only when the value is being configured under endpoint configuration.

Releases prior to 15.0, when the IP CAN session falls back to local policy it remained with local policy until the termination timer expires or the subscriber disconnects. Also, the RAR message received when the local-policy timer was running got rejected with the cause "Unknown Session ID".

In 15.0 and later releases, P-GW/GGSN provides a fair chance for the subscriber to reconnect with PCRF in the event of CCR failure. To support this feature, configurable validity and peer backoff timers are introduced in the Local Policy Service and Diameter endpoint configuration commands. Also, the RAR received when the local-policy timer is running will be rejected with the cause "DIAMETER_UNABLE_TO_DELIVER".

In releases prior to 17.0, rule report was not sent in the CCR messages when PCRF is retried after the expiry of validity timer. In 17.0 and later releases, rule report will be sent to the PCRF during reconnect when the CLI command **diameter encodeevent-avps local-fallback** is configured under Policy Control Configuration mode.

Support for Volume Reporting in Local Policy

This feature provides support for time based reconnect to PCRF instead of the event based for CCR-U failure scenarios.

In releases prior to 17.0, the following behaviors were observed with respect to the Volume Reporting for Local Policy:

- In the event of CCR-U failure, CCR-U was triggered to PCRF only on receiving subscriber event.
- When a CCR-U failure happened and a call continued without Gx, unreported volume is lost as the threshold is set to infinity. In next CCR-U triggered to PCRF, the cumulative volume was sent to PCRF.
- RAR was rejected with result-code `diameter_unable_to_comply` (3002) when the validity timer is running.

In 17.0 and later releases, with the timer-based implementation, this feature introduces the following changes to the existing behavior:

- When send-usage-report is configured, the CCR-U with usage report will be sent immediately after the local-policy timer-expiry.
- The unreported usage will not be returned to ECS. Thus, usage since last tried CCR-U will be sent to PCRF.
- RAR will be accepted and the rules received on RAR will be installed even when the timer is running.

Session can be connected to PCRF immediately instead of waiting for subscriber event, and the updated usage report can be sent.

Support for Session Recovery and Session Synchronization

Currently PCRF and ASR 5500 gateway node are in sync during normal scenarios and when Gx assume positive is not applied. However, there are potential scenarios where the PCRF might have been locally deleted or lost the Gx session information and it is also possible that due to the loss of message, gateway node and PCRF can be out of sync on the session state.

While these are rare conditions in the network, the desired behavior is to have PCRF recover the Gx session when it is lost and also to have PCRF and gateway sync the rule and session information. This feature provides functionality to ensure PCRF and gateway can sync on session information and recover any lost Gx sessions. Configuration support has been provided to enable session recovery and session sync features.

In releases prior to 17.0, the implementation is as follows:

- If the PCRF deletes or loses session information during a Gx session update (CCR-U) initiated by the gateway, PCRF will respond back with DIAMETER_UNKNOWN_SESSION_ID resulting in session termination even in the case of CCR-U.
- If the PCRF deletes or loses session information and an Rx message is received, PCRF will not be able to implement corresponding rules and will result in failure of subscriber voice or video calls.
- For subscriber's existing Rx sessions and active voice/video calls, PCRF will not be able to initiate cleanup of the sessions towards the gateway and can result in wastage of the resources in the network (dedicated bearers not removed) or can result in subscriber not able to place calls on hold or conference or remove calls from hold.
- For out of sync scenarios, PCRF and gateway could be implementing different policies and can result in wastage of resources or in poor subscriber experience. Existing behavior does not provide for a way to sync the entire session information.

In 17.0 and later releases, the gateway (GW) node and PCRF now supports the ability to exchange session information and the GW provides the complete subscriber session information to enable PCRF to build the session state. This will prevent the occurrence of the above mentioned scenarios and ensure that GW and PCRF are always in sync. The keywords **session-recovery** and **session-sync** are used with the **diameter encode-supported-features** CLI command in Policy Control Configuration mode to support Gx Synchronization.

Configuring Gx Assume Positive Feature

To configure Gx Assume Positive functionality:

-
- Step 1** At the global configuration level, configure Local Policy service for subscribers as described in the [Configuring Local Policy Service at Global Configuration Level, on page 278](#).
 - Step 2** At the global configuration level, configure the failure handling template to use the Local Policy service as described in the [Configuring Failure Handling Template at Global Configuration Level, on page 279](#).
 - Step 3** Within the IMS Authorization service, associate local policy service and failure handling template as described in the [Associating Local Policy Service and Failure Handling Template, on page 279](#).
 - Step 4** Verify your configuration as described in the [Verifying Local Policy Service Configuration, on page 279](#).
 - Step 5** Save your configuration to flash memory, an external memory device, and/or a network location using the Exec mode command **save configuration**. For additional information on how to verify and save configuration files, refer to the *System Administration Guide* and the *Command Line Interface Reference*.

Important Commands used in the configuration examples in this section provide base functionality to the extent that the most common or likely commands and/or keyword options are presented. In many cases, other optional commands and/or keyword options are available. Refer to the *Command Line Interface Reference* for complete information regarding all commands.

Configuring Local Policy Service at Global Configuration Level

Use the following example to configure Local Policy Service at global configuration level for subscribers:

```

configure
  local-policy-service LOCAL_PCC
    ruledef 2G_RULE
      condition priority 1 apn match .*
      exit
    ruledef all-plmn
      condition priority 1 serving-plmn match .*
      exit
    actiondef 2G_UPDATE
      action priority 1 activate-ambr uplink 18000 downlink 18000
      action priority 2 reject-requested-qos
      exit
    actiondef action1
      action priority 2 allow-requested-qos
      exit
    actiondef allow
      action priority 1 allow-session
      exit
    actiondef delete
      action priority 1 terminate-session
      exit
    actiondef lp_fall
      action priority 1 reconnect-to-server
      exit
    actiondef time
      action priority 1 start-timer timer duration 10
    exit
  eventbase default
    rule priority 1 event fallback ruledef 2G_RULE actiondef time
  continue
    rule priority 2 event new-call ruledef 2G_RULE actiondef action1
    rule priority 3 event location-change ruledef 2G_RULE actiondef
  action1
    rule priority 5 event timer-expiry ruledef 2G_RULE actiondef
  lp_fall
    rule priority 6 event request-qos default-qos-change ruledef
  2G_RULE actiondef allow
  end

```

Notes:

- On occurrence of some event, event will be first matched based on the priority under the eventbase default. For the matched rule and if the corresponding ruledef satisfies, then specific action will be taken.

Configuring Failure Handling Template at Global Configuration Level

Use the following example to configure failure handling template at global configuration level:

```
configure
  failure-handling-template <template_name>
    msg-type any failure-type any action continue local-fallback
  end
```

Notes:

- When the TCP link failure, Application Timer (Tx) expiry, or Result code based failure happens, the associated failure-handling will be considered and if the failure-handling action is configured as local-fallback, then call will fall back to local-fallback mode.

Associating Local Policy Service and Failure Handling Template

Use the following example to associate local policy service and failure handling template:

```
configure
  context <context_name>
    ims-auth-service <service_name>
      associate local-policy-service <lp_service_name>
      associate failure-handling <failure-handling-template-name>
    end
```

Verifying Local Policy Service Configuration

To verify the local policy service configuration, use this command:

```
show local-policy statistics service service_name
```

Time Reporting Over Gx

This section describes the Time Reporting over Gx feature supported for GGSN in this release.

License Requirements

No separate license is required for Time Reporting over Gx feature. This feature can be enabled as part of "Policy Interface" license.

Contact your Cisco account representative for detailed information on specific licensing requirements. For information on installing and verifying licenses, refer to the *Managing License Keys* section of the *Software Management Operations* chapter in the *System Administration Guide*.

Feature Overview

This non-standard Time Usage Reporting over Gx feature is similar to Volume Usage Reporting over Gx. PCRF provides the time usage threshold for entire session or particular monitoring key in CCA or RAR. When the given threshold breached usage report will be sent to PCRF in CCR. This time threshold is independent of data traffic. Apart from the usage threshold breach there are other scenarios where usage report will be sent to PCRF.



Important Time reporting over Gx is applicable only for time quota.

The PCEF only reports the accumulated time usage since the last report for time monitoring and not from the beginning.

If the time usage threshold is set to zero (infinite threshold), no further threshold events will be generated by PCEF, but monitoring of usage will continue and be reported at the end of the session.

Time usage reporting on bearer termination is supported. When a bearer is deleted due to some reason, the rules associated with the bearer will also be removed. So, the usage will be reported on the monitoring key(s) whose associated rule is the last one that is removed because of bearer termination.

The following steps explain how Time Reporting over Gx works:

1. PCEF after receiving the message from PCRF parses the time monitoring related AVPs, and sends the information to IMSA.
2. IMSA updates the information to ECS.
3. Once the ECS is updated with the time monitoring information from PCRF, the PCEF (ECS) starts tracking the time usage.
4. For session-level monitoring, the ECS maintains the amount of time usage.
5. For PCC rule monitoring, usage is monitored with the monitoring key as the unique identifier. Each node maintains the time usage information per monitoring key.
6. The PCEF continues to track time usage after the threshold is reached and before a new threshold is provided by the PCRF. If a new usage threshold is not provided by the PCRF in the acknowledgement of an IP-CAN Session modification where its usage was reported, then time monitoring does not continue in the PCEF for that IP CAN session.

Limitations

This section lists the limitations for Time Reporting over Gx in this release.

- Only integer monitoring key will be supported like Volume Reporting over Gx
- If the same monitoring key is used for both time and data volume monitoring then disabling monitoring key will disable both time and data usage monitoring.
- If the same monitoring key is used for both time and data usage monitoring and if an immediate report request is received, then both time and volume report of that monitoring key will be sent.

Usage Monitoring

Two levels of time usage reporting are supported:

- Usage Monitoring at Session Level
- Usage Monitoring at Flow Level

Usage Monitoring at Session Level

PCRF subscribes to the session level time reporting over Gx by sending the Usage-Monitoring-Information AVP with the usage threshold level set in Granted-Service-Unit AVP and Usage-Monitoring-Level AVP set to SESSION_LEVEL (0).

Usage Monitoring at Flow Level

PCRF subscribes to the flow level time reporting over Gx by sending the Usage-Monitoring-Information AVP with the usage threshold level set in Granted-Service-Unit AVP and Usage-Monitoring-Level AVP set to PCC_RULE_LEVEL(1). Monitoring Key is mandatory in case of a flow level monitoring since the rules are associated with the monitoring key and enabling or disabling of usage monitoring at flow level can be controlled by PCRF using it. Usage monitoring is supported for both predefined rules and dynamic rule definition.

Usage Monitoring for Predefined and Static Rules

If the usage monitoring needs to be enabled for the predefined rules, PCRF sends the rule and the usage monitoring information containing the monitoring key and the usage threshold. The monitoring key should be same as the one pre-configured in PCEF for that predefined rule. There can be multiple rules associated with the same monitoring key. Hence enabling a particular monitoring key would result in the time being tracked for multiple rules having the same monitoring key. Similarly, usage monitoring information is sent from PCRF for the static rules also.

Usage Monitoring for Dynamic Ruledefs

If the usage monitoring needs to be enabled for dynamic ruledefs, PCRF provides the monitoring key along with a charging rule definition and the usage monitoring information containing the monitoring key and the usage threshold. This results in the usage monitoring being done for all the rules associated with that monitoring key.

Usage Reporting

Time usage at subscriber/flow level is reported to PCRF under the following conditions:

- **Usage Threshold Reached:** PCEF records the subscriber usage and checks if the usage threshold provided by PCRF is reached. Once the condition is met, it reports the usage information to IMSA and continues monitoring. IMSA then triggers the CCR-U if "USAGE_REPORT" trigger is enabled by PCRF. The Usage-Monitoring-Information AVP is sent in this CCR with the "CC-Time" in "Used-Service-Unit" set to track the time usage of the subscriber.
- **Usage Monitoring Disabled:** If PCRF explicitly disables the usage monitoring with Usage-Monitoring-Support AVP set to USAGE_MONITORING_DISABLED, PCEF stops monitoring and reports the usage information (when the monitoring was enabled) to PCRF if the usage monitoring is disabled by PCRF as a result of CCR from PCEF which is not related to reporting usage, other external triggers, or a PCRF internal trigger.
- **IP CAN Session Termination:** When the IP CAN session is terminated, the accumulated subscriber usage information is reported to PCRF in the CCR-T from PCEF.

PCRF uses RAR message and includes Session-Release-Cause AVP in it to initiate IP CAN Session Termination. However, there are some scenarios where PCRF may want to terminate the IP CAN Session in CCA messages. In order to avoid an unnecessary additional message, PCRF can inform P-GW to terminate the subscriber in CCA-U message itself. Hence, in 17.0 and later releases, the Session Release Cause has been added in CCA messages for all Gx dictionaries.

- **PCC Rule Removal:** When the PCRF deactivates the last PCC rule associated with a usage monitoring key, PCEF sends a CCR with the usage time for that monitoring key. If the PCEF reports the last PCC rule associated with a usage monitoring key is inactive, the PCEF reports the accumulated usage for that monitoring key within the same CCR command if the Charging-Rule-Report AVP was included in a CCR command; otherwise, if the Charging-Rule-Report AVP was included in an RAA command, the PCEF sends a new CCR command to report accumulated usage for the usage monitoring key.

- **PCRF Requested Usage Report:** When PCRF provides the Usage-Monitoring-Information with the Usage-Monitoring-Report set to `USAGE_MONITORING_REPORT_REQUIRED`, PCEF sends the time usage information. If the monitoring key is provided by PCRF, time usage for that monitoring key is notified to PCRF regardless of usage threshold. If the monitoring key is not provided by PCRF, time usage for all enabled monitoring keys is notified to PCRF.
- **Event Based Reporting:** The event based reporting can be enabled through the CLI command **event-update send-usage-report events**. When an event like sgsn change, qos change or revalidation-timeout is configured under this CLI, time usage report is generated whenever that event happens.

Once the usage is reported, the usage counter is reset to zero. The PCEF continues to track time usage from the zero value after the threshold is reached and before a new threshold is provided by the PCRF. If a new usage threshold is not provided by the PCRF in the acknowledgement of an IP-CAN Session modification where its usage was reported, then time usage monitoring does not continue in the PCEF for that IP CAN session.

For information on how to configure the Time Reporting over Gx feature, see the [Configuring Time Reporting over Gx, on page 282](#).

Configuring Time Reporting over Gx

This section describes the configuration required to enable Time Reporting over Gx.

To enable Time Reporting over Gx, use the following configuration:

```
configure
  active-charging service <ecs_service_name>
    rulebase <rulebase_name>
      action priority <priority> dynamic-only ruledef <ruledef_name>
  charging-action <charging_action_name> monitoring-key <monitoring_key>
  exit
  exit
  context <context_name>
    ims-auth-service <imsa_service_name>
      policy-control
        event-update send-usage-report [ reset-usage ]
      end
  end
```

Notes:

- The configuration for enabling Time Reporting over Gx is same as the Volume Reporting over Gx configuration. If a time threshold is received from PCRF then Time monitoring is done, and if a volume threshold is received then Volume monitoring will be done.
- The maximum accepted monitoring key value by the PCEF is 4294967295. If the PCEF sends a greater value, the value is converted to an Unsigned Integer value.
- The **event-update** CLI enables time usage report to be sent in event updates. The optional keyword **reset-usage** enables to support delta reporting wherein the usage is reported and reset at PCEF. If this option is not configured, the behavior is to send the time usage information as part of event update but not reset at PCEF.

Support for Multiple Active and Standby Gx Interfaces to PCRF

In the earlier Gx implementation, Diameter Policy Control Application has the limitation to mandatorily configure hosts as part of IMS Authorization service or associate a host template and select the hosts to be communicated for each subscriber session. Since the peer selection can happen at diabase and application need not select any hosts, this feature is developed to remove the restrictions imposed in the application and allow diabase to pick the peers in a round robin fashion. In addition, this feature will take care of peer selection at diabase even when the hosts picked by application are not active. This change in behavior is controlled through the CLI command "**endpoint-peer-select**" as the default behavior is to drop the call if the server discovery fails at application.

When the call is established, IMSA module checks the host selection table/prefix table/host template associated in IMSA service to pick the primary and secondary peers to be contacted. If no host table/prefix table/host template is configured or none of the rows in prefix table are matching or the hosts selected by IMSA are inactive, then based on the CLI configuration the control is given to diabase module which will select the peers in a round robin fashion or terminate the call based on the CLI configuration.

When the CCR message results in a diabase error/Tx expiry/response timeout, then IMSA will let diabase select an alternate route by excluding the peer which resulted in the failure and switch to the peer if the lookup is successful.

When CCR/CCA message is exchanged with the directly connected host selected by diabase and RAR message is received from new host, then IMSA will skip host configuration check and let further communication to happen with the new host. If the directly connected host is selected by application during call establishment, then IMSA will check if the new host is the secondary server per application. When the CCR/CCA message is exchanged with indirectly connected host through DRA which is picked by diabase and RAR message is received from same host through another DRA, then IMSA will skip host configuration check and let further communication to happen with the same host through the new DRA. If the DRA is selected by application during call establishment, then IMSA will check if the new DRA is the secondary server per application. Even if RAR message is received from different host though another DRA, IMSA will skip host configuration check and let further communication to happen with the new host through the new DRA.

Configuring Diameter Peer Selection at Diabase in Failure Scenarios

The following configuration enables diabase to select the Diameter peers when IMSA fails.

```

configure
  context context_name
    ims-auth-service service_name
      policy-control
        endpoint-peer-select [ on-host-select-failure |
on-inactive-host ]
          { default | no } endpoint-peer-select
        end
      end
    end
  end

```

Notes:

- This command is used to perform server selection at diabase when the hosts could not be selected by IMS Authorization application or when the hosts selected by the IMS Authorization application is inactive. For example, host table is not configured in IMSA service, host table is configured but not activated, none of the rows in prefix table match the subscriber, host template is not associated with IMSA service, host template could not select the hosts.
- **on-host-select-failure**: Specifies to perform server selection at Diabase when the hosts could not be selected by IMS Authorization application.

- **on-inactive-host**: Specifies to perform server selection at database when the hosts selected by application are inactive.
- This CLI command is added in policy control configuration mode to maintain backward compatibility with the old behavior of terminating the call when server selection fails at IMS Authorization application.

Support for Multiple CCR-U's over Gx Interface

ASR 5500 node earlier supported only one pending CCR-U message per session over Gx interface. Any request to trigger CCR-U (for access side updates/internal updates) were ignored/dropped, when there was already an outstanding message pending at the node. PCEF and PCRF were out of synch if CCR-U for critical update was dropped (like RAT change/ULI change).

In 17.0 and later releases, ASR 5500 supports multiple CCR-U messages at a time per session through the use of a configurable CLI command "**max-outstanding-ccr-u**" under IMS Authorization Service configuration mode. That is, this CLI will allow the user to configure a value of up to 12 as the maximum number of CCR-U messages per session.

The CLI-based implementation allows sending request messages as and when they are triggered and processing the response when they are received. The gateway does re-ordering if the response messages are received out of sequence.

To support multiple outstanding messages towards PCRF, the following items should be supported:

- Allowing IMSA to send multiple CCR-U messages – This can be achieved through the use of **max-outstanding-ccr-u** command in the IMS Authorization Service configuration mode.
- Queuing of response message for ordering – DPCA should parse the received message irrespective of order in which they are received. IMSA will check whether to forward the response to session manager or queue it locally.
- Peer switch – When multiple CCR-U's are triggered, IMSA will start Tx timer for each request sent out. On first Tx expiry, IMSA/DPCA will do peer switch. That is, IMSA will stop all other requests' Tx timers and switch to secondary peer (if available) or take appropriate failure handling action.
- Failure handling – On peer switch failure due to Tx expiry, DPCA will take failure handling action based on the configuration present under `ims-auth-service`.
- Handling back pressure – In case of multiple CCR-U's triggered to Primary PCRF and due to Tx timeout all the messages are switched to Secondary PCRF. If Secondary server is already in backpressure state, then IMSA will put first message in the backpressure queue and once after message is processed next pending request will be put into BP queue.
- Volume reporting – In case of multiple CCR-U's for usage report is triggered (for different monitoring keys) and failure handling is configured as "**continue send-ccrt-on-call-termination**", on first Tx timeout or response timeout, usage report present in all the CCR-U's will be sent to ECS. All the unreported usage will be sent in CCR-T message when the subscriber goes down. If "**event-update send-usage-report**" CLI is present, then there are chances of reporting usage for same monitoring key in multiple CCR-U's.

Though the **max-outstanding-ccr-u** CLI command supports configuring more than one CCR-U, only one outstanding CCR-U for access side update is sent out at a time and multiple CCR-U's for internal updates are sent.

These are the access side updates for which CCR-U might be triggered:

- Bearer Resource Command
- Modify Bearer Request (S-GW change, RAT change, ULI change)
- Modify Bearer Command

These are the following internal updates for which CCR-U is triggered:

- S-GW restoration
- Bearer going down (GGSN, BCM UE_Only)
- ULI/Timezone notification
- Default EPS bearer QoS failure
- APN AMBR failure
- Charging-Rule-Report
- Out of credit / reallocation of credit
- Usage reporting
- Tethering flow detection
- Access network charging identifier

Configuring Gateway Node to Support Back-to-Back CCR-Us

The following configuration enables or disables the gateway to send multiple back-to-back CCR-Us to PCRF.

```
configure
  context context_name
    ims-auth-service service_name
      policy-control
        [ default ] max-outstanding-ccr-u value
      end
    end
```

Notes:

- *value* must be an integer value from 1 through 12. The default value is 1.

Support for RAN/NAS Cause IE on Gx Interface

New supported feature "Netloc-RAN-NAS-Cause" has been introduced to be in compliance with the Release 12 specification of 3GPP TS 29.212. This feature is used to send detailed RAN and/or NAS release cause code information from the access network to PCRF. It requires that the NetLoc feature is also supported.



Important

This feature can be enabled only when the NetLoc feature license is installed.

A new Diameter AVP "RAN-NAS-Release-Cause" will be included in the Charging-Rule-Report AVP and in CCR-T for bearer and session deletion events respectively, when the NetLoc-RAN-NAS-Cause supported feature is enabled. This AVP will indicate the cause code for the subscriber/bearer termination.

Configuring Supported Feature Netloc-RAN-NAS-Cause

The following configuration enables the supported feature "Netloc-RAN-NAS-Cause".

```
configure
  context context_name
    ims-auth-service service_name
      policy-control
        diameter encode-supported-features netloc-ran-nas-cause
      end
    end
```

Notes:

- **netloc-ran-nas-cause:** Enables the Netloc-RAN-NAS-Cause feature. By default, this supported feature will be disabled.
- If the supported features "netloc-ran-nas-code" and "netloc" are enabled, then netloc-ran-nas-cause code will be sent to PCRF.

To disable this supported feature, use the following command:

```
[ default | no ] diameter encode-supported-features
```

Support ADC Rules over Gx Interface

In this release, P-GW will use Application Detection and Control (ADC) functionality over Gx as defined in the Release 11 specification of 3GPP standard.

ADC extension over Gx provides the functionality to notify PCRF about the start and stop of a specific protocol or a group of protocols, and provide the possibility to PCRF that with the knowledge of this information, change the QoS of the user when the usage of application is started and until it is finished.

The provision of ADC information is done through the ADC rule, the action initiated by PCRF is done through the PCC rule.

ADC rules are certain extensions to dynamic and predefined PCC rules in order to support specification, detection and reporting of an application flow. These rules are installed (modified/removed) by PCRF via CCA-I/CCA-U/RAR events. ADC rules can be either dynamic PCC or predefined PCC rules, and the existing attributes of dynamic and predefined rules will be applicable.

Dynamic PCC rule contains either traffic flow filters or Application ID. When Application ID is present, the rule is treated as ADC rule. Application ID is the name of the ruledef which is pre-defined in the boxer configuration. This ruledef contains application filters that define the application supported by P2P protocols.

PCEF will process and install ADC rules that are received from PCRF interface, and will detect the specified applications and report detection of application traffic to the PCRF. PCRF in turn controls the reporting of application traffic.

PCEF monitors the specified applications that are enabled by PCRF and generates Start/Stop events along with the Application ID. Such application detection is performed independent of the bearer on which the ADC PCC rule is bound to. For instance, if ADC rule is installed on a dedicated bearer whereas the ADC traffic is received on default bearer, application detection unit still reports the start event to PCRF.



Important

ADC Rule support is a licensed-controlled feature. Contact your Cisco account representative for detailed information on specific licensing requirements.

In support of this feature, the following Diameter AVPs are newly added to the Charging-Rule-Definition AVP, which PCEF will receive from PCRF.

- **TDF-Application-Identifier:** It references the application detection filter which the PCC rule for application detection and control in the PCEF applies. The TDF-Application-Identifier AVP references also the application in the reporting to the PCRF.
- **Redirect-Information:** This indicates whether the detected application traffic should be redirected to another controlled address.
- **Mute-Notification:** This AVP is used to mute the notification to the PCRF of the detected application's start/stop for the specific ADC/PCC rule from the PCEF.

- Application Detection Information: If Mute-Notification AVP is not enclosed with charging rule report and APPLICATION_START/APPLICATION_STOP event trigger is enabled then PCEF will send Application-Detection-Information to PCRF corresponding TDF-Application-Identifier.

In addition, these two new event triggers "APPLICATION_START" and "APPLICATION_STOP" are generated for reporting purpose.

Limitations

The limitations for the ADC over Gx feature are:

- ADC does not support group of ruledefs.
- Registration of the duplicate application IDs are not supported.
- Readdress/Redirection for P2P flows will not be supported.
- Redirection happens only on transactions of GET/Response.
- Port based, IP Protocol based, and URL based applications are not supported.
- Pre-configured options (precedence, redirect-server-ip) for dynamic ADC rules are not supported.
- Simultaneous instances of an application for the same subscriber are not distinguished.
- Flow recovery is not supported for application flows.

Configuring ADC Rules over Gx

The following configuration enables ADC rules over Gx interface.

```
configure
  context context_name
    ims-auth-service service_name
      policy-control
        diameter encode-supported-features adc-rules
      end
    end
```

Notes:

- The keyword "**adc-rules**" will be available only when the feature-specific license is configured.
- For ADC 6th bit of supported feature will be set.

To disable the support for ADC Rules over Gx, use the following command:

```
[ default | no ] diameter encode-supported-features
```

GoR Name Support in TDF-Application-Identifier

ASR 5500 supports dynamic rules to be installed with GoR name as TDF-Application-Identifier. When ADC rule is installed as a dynamic rule from PCRF, the TDF-Application-Identifier can include the GoR name pre-configured in the P-GW.

If the ADC feature is enabled, PCRF can send TDF-Application-Identifier as the name of GoR predefined in the P-GW configuration.

- When dynamic charging-rules with the Charging-Rule-Definition AVP are activated from PCRF, the PCRF can specify the GoR name configured in ECS as TDF-Application-Identifier.
- When dynamic charging-rules with the Charging-Rule-Definition AVP are activated, the PCRF can remove or modify the rule through the Charging-Rule-Definition using RAR. During rule activation or modification, the PCRF can add, modify or remove the charging-rule attributes of the rule.

The configuration changes for TDF-Application-Identifier from PCRF are listed below:

- A non-ADC dynamic rule can be changed to ADC dynamic rule by sending TDF-Application-Identifier AVP with relevant ruledef or GoR name.
ADC dynamic rule cannot be changed to non-ADC dynamic rule.
- The following AVPs will be modified and applied when received from PCRF:
 - Precedence
 - Rating-Group/Service-Identifier/Sponsor-Identity (mandatory depending on the Reporting-Level)
 - Metering-Method
 - Online/Offline
 - QoS-Information
 - Monitoring-Key
 - Redirect-Information
- Dynamic route will be updated for all protocols of rules that are part of TDF-Application-Identifier GoR.
- Any change in dynamic rule priority or TDF-Application-Identifier value will lead to sending of APP-START and APP-STOP event notifications as new rule match. If an APP-START notification was sent already before rule modification, the corresponding APP-STOP notification will not be sent.
- Runtime deletion of associated GoR will take immediate effect and APP-STOP notification will not be sent if an APP-START was already sent. Addition of GoR at service level will need to have rules to be re-installed for the new addition to take effect for both dynamic and predefined ADC rules.

ADC Mute Customization

Earlier, 3GPP ADC over Gx did not support application MUTE status change. Once the application was muted, it was not possible to unmute it. From release 21.1, this feature introduces custom MUTE/UNMUTE functionality. ASR 5500 PCEF now supports customization to control reporting of the Application Detection Information CCRUs. For this, an AVP has been introduced with two possible values - custom MUTE and custom UNMUTE.

- A Gx message might contain both Standards based MUTE and the custom MUTE.
- Standards based MUTE is given preference over the custom MUTE/UNMUTE.
- A dynamic ADC rule can be installed and modified with a custom MUTE.
- Custom-Mute-Notification AVP can be sent by the PCRF in CCA-I and RAR.
- A dynamic ADC rule can be modified with a custom UNMUTE.
- On a custom MUTE for a given dynamic ADC rule, PCEF sends a single APPLICATION_START/ APPLICATION_STOP response for the entire application traffic rather the per flow APPLICATION_START/APPLICATION_STOP response.
- On a custom MUTE for a given dynamic ADC rule, if no APPLICATION_START has been sent prior to the custom MUTE then a single APPLICATION_START is sent on the next flow packet that hits the dynamic rule.
- On a custom MUTE for a given dynamic rule, the APPLICATION_START response is sent with the flow's 5-tuple information.

- On a custom MUTE for a given dynamic rule, the APPLICATION_START response is sent with TDF-Application-Instance-Identifier = 0.
- On a custom MUTE for a given dynamic rule, a single APPLICATION_STOP is sent when the last flow associated with the given dynamic rule is terminated. Such an APPLICATION_STOP will not contain 5-tuple information of the last flow and is sent with TDF-Application-Instance-Identifier = 0.
- On a custom UNMUTE for a given dynamic rule, APPLICATION_STARTs response is matched with the given dynamic rule and then sent to all the forthcoming flows.
- There is no change in behavior for a custom UNMUTE, which has not been custom MUTED or standard MUTED before UNMUTING. APPLICATION_STARTs and APPLICATION_STOPs is continued to be sent per flow as before.
- On a custom UNMUTE, PCEF sends an APPLICATION_STOP each for all flows that terminate then onwards.
- A given dynamic rule is recovered in both SR and ICSR including the Custom MUTE/UNMUTE status. The APPLICATION_START status for a given dynamic rule is check-pointed and recovered. This ensures that an extra APPLICATION_START is not sent to the PCRF post recoveries.

Enhancement to the ADC Custom Mute/Unmute Functionality

Feature Information

Summary Data

Status	Modified Functionality
Introduced-In Release	21.1
Modified-In Release(s)	21.2
Applicable Product(s)	SAEGW
Applicable Platform(s)	ASR 5500
Default Setting	Disabled
Related CDETS ID(s)	CSCvd00699
Related Changes in This Release	Not Applicable
Related Documentation	Command Line Interface Reference SAEGW Administration Guide

Revision History



Important

Revision history details are not provided for features introduced before release 21.2.

Revision Details	Release	Release Date
Modified in this release.	21.2	April 27, 2017

Feature Changes

The "ADC mute customization" feature introduced custom MUTE/UNMUTE functionality to control reporting of the Application Detection Information CCRUs. With the custom MUTE PCRF AVP, the PCRF informed P-GW when to disable/enable the ADC application notifications.

This feature enhances the "ADC mute customization" feature further and report the flow activities between custom mute and unmute events. P-GW learns the flow activities between custom mute events and then reports them to PCRF after the custom unmute event has occurred on the ADC rule. It minimizes the ADC application start and stop mechanism in standard ADC mute and unmute case.

A new CLI command has been implemented at the rulebase, which when configured, reports ADC application start and stop notifications only once per rule. This helps in reducing messaging flows towards the PCRF.

Limitations

Following are the limitations of this feature:

- P-GW stores maximum of 12 learned flows per ADC rule. Once the limit 12 has been reached, P-GW forgets the oldest flow and learns about the latest flow. Once P-GW receives the custom unmute event, it notifies the PCRF about the learned notifications. P-GW sends application stop notification, if the application start notification for the flow is sent.
- Flow information stored for sending the application start notifications to the PCRF after the event of the custom unmute is not recovered.
- On LTE to WiFi handover, the values received from the PCRF for custom mute or custom unmute per ADC dynamic rule gets applied in the new RAT. If there is no value received in the handover context, the previous values before the RAT change are retained for all the ADC dynamic rules which are present.
- If the CLI command **adc notify** is enabled, then the single ADC application start and stop notification is notified to the PCRF. If there are multiple flows which match the same ADC dynamic rule, only one application start and stop notification is sent to the PCRF.
- This feature is implemented only for the dynamic rules.

How it Works

Following is the sequence of events that occur when P-GW receives packet and ADC rule event occurs from PCRF:

1. Packet reaches the ECS rule matching engine.
2. The rule matching engine checks if the ADC dynamic rule is matched. It also checks if the custom mute is applied through the PCRF or rulebase level CLI. A single application start notification is sent, if not sent earlier.
3. For all the subsequent flows matching the same ADC rule, application start notification is stored. These notifications are sent in the CCRU after the custom unmute event is received.

Following are some important points:

- The values received from the PCRF has the highest priority. Hence, standard mute has the highest priority than custom-mute/custom-unmute. The CLI *adc notify once* has the least priority.
- If the CLI **adc notify once** is configured at the rulebase, the converse **no adc notify** does not have any impact. To converse the CLI impact, do either of the following tasks:

- Switch the rulebase in which the CLI **adc notify once** is not configured.
- Send the "custom unmute" for that particular dynamic rule.

Configuring the ADC Notifications

The new CLI command, **adc notify**, has been added to the active charging service mode.

When this CLI is configured, a single application start or application stop notification for the ADC flow matching per rule is sent to the PCRF. If this CLI is configured and the PCRF sends the custom mute notification, then the PCRF notification takes precedence over the standard behavior for reporting the notification.

The default value of this keyword is false. If this CLI is not configured, then no action is taken on sending the ADC notifications.

To enable or disable the feature, enter the following commands:

```
configure
  active-charging service <service_name>
    rulebase <rulebase_name>
      [no] adc notify [once]
    end
```

For configuring single notification use the following command:

```
adc notify once
```

Notes:

- **no**: Disables the ADC notifications and ADC notifications are sent as per default behavior.
- **adc**: Configures the ADC notifications.
- **notify**: Configures the application notification. If this keyword is not configured, ADC notifications are sent as per default behavior.
- **once**: Configures the application notification only once. PCRF takes the priority.

Support for TAI and ECGI Change Reporting

This section describes the overview and implementation of TAI and ECGI Change Reporting feature.

This section discusses the following topics for this feature:

- [Feature Description, on page 291](#)
- [How it Works, on page 292](#)
- [Monitoring and Troubleshooting the TAI and ECGI Change Reporting Feature, on page 293](#)

Feature Description

For activating User Location Reporting for a UE over Gx, PCRF sends RAR/CCA with the "USER_LOCATION_CHANGE (13)" event trigger. On receiving this event trigger, P-GW typically sends

Change Reporting Action (CRA) Information Element (IE) with "Start Reporting" towards MME to enable the Location-Change reporting for the UE in MME.

In the current architecture, the "USER_LOCATION_CHANGE (13)" trigger is used to report the changes in User Location Information (ULI), Tracking Area Identity (TAI) and E-UTRAN Cell Global Identifier (ECGI). In release 19.4 and beyond, separate event triggers TAI_CHANGE (26) and ECGI_CHANGE (27) are supported for reporting the changes in TAI and ECGI correspondingly. CLI changes are done to display the new event triggers in show configuration commands.



Important

For TAI reporting to work, the **diameter map usage-report** CLI command must be configured in Policy Control configuration mode to use the value 33.

PCRF subscribes to the CRA event for reporting change of TAI and ECGI. P-GW sends event trigger in CCR-U only if it is subscribed by PCRF. When PCRF installs the event trigger for ECGI Change and/or TAI change, any change in ECGI and TAI (based on installed triggers) is reported.

The TAI and ECGI Change Reporting feature complies with 3GPP TS 29.212 v9.7.0. This feature is supported on Gx interface so that UE can be tracked on ECGI/TAI change and reported to PCRF. For more information on the User Location Information Reporting feature, see the administration guide for the product that you are deploying.

In releases prior to 19.3, the CRA event included in Create Session Response (CSRsp) for reporting location change was always set to START_REPORTING_ECGI (4).

In release 19.4 and beyond, the CRA value varies based on the event triggers received from PCRF.

Change Reporting Support Indication (CRSI) and ULI are also supported in Bearer Resource Command.

P-GW sends the ULI received in Delete Bearer Command from MME to PCRF when the corresponding Delete Bearer Response is received. When the ULI is included in both Delete Bearer Command and Delete Bearer Response, the ULI in Delete Bearer Response is sent to the PCRF. In the absence of ULI in Delete Bearer Response, then the ULI received in Delete Bearer Command is sent to PCRF.

Relationships to Other Features

This feature has a dependency on USAGE_REPORT value of Event-Trigger AVP. This feature works only when the value of USAGE_REPORT is set to 33. This can be achieved using the **diameter map usage-report** CLI command in Policy Control configuration mode.

How it Works

P-GW sends Event Trigger value based on the event trigger detected by P-GW in CCR-U. P-GW sends Event Trigger and ULI Type in CCR-U to PCRF as per the following table.

Event Trigger from PCRF	CRA Value	Event Detected at P-GW	What to Inform PCRF
ULI_CHANGE	6	TAI_CHANGE or ECGI_CHANGE	Event Trigger: ULI_CHANGE ULI Type: TAI + ECGI
TAI_CHANGE	3	TAI_CHANGE	Event Trigger: TAI_CHANGE ULI Type: TAI

Event Trigger from PCRF	CRA Value	Event Detected at P-GW	What to Inform PCRF
ECGI_CHANGE	4	ECGI_CHANGE	Event Trigger: ECGI_CHANGE ULI Type: ECGI
ULI_CHANGE + TAI_CHANGE	6	TAI_CHANGE	Event Trigger: ULI_CHANGE+ TAI_CHANGE ULI Type: TAI+ECGI
ULI_CHANGE + ECGI_CHANGE	6	ECGI_CHANGE	Event Trigger: ULI_CHANGE + ECGI_CHANGE ULI Type: TAI+ECGI
ULI_CHANGE + TAI_CHANGE + ECGI_CHANGE	6	TAI/ECGI has changed	Event Trigger: ULI_CHANGE + TAI/ECGI CHANGE ULI_Type: TAI+ECGI
TAI_CHANGE + ECGI_CHANGE	6	TAI/ECGI has changed	Event Trigger: TAI_CHANGE/ECGI_CHANGE ULI_Type: TAI+ECGI
For combinations not specifically mentioned above	6		Event Trigger: ULI_CHANGE ULI_Type: TAI+ECGI

Limitations

TAI and ECGI Change Reporting feature is supported only when *diameter map usage-report* CLI command is configured as 33.

Monitoring and Troubleshooting the TAI and ECGI Change Reporting Feature

This section provides information regarding show commands and/or their outputs in support of the TAI and ECGI Change Reporting feature.

show ims-authorization sessions full all

The following fields are added to the output of this show command in support of this feature:

- TAI-Change - Displays this event trigger when TAI has changed for a subscriber session.
- ECGI-Change - Displays this event trigger when ECGI has changed for a subscriber session.

show ims-authorization service statistics all

The following statistics are added to the output of this show command in support of this feature:

- TAI Change - Displays the total number of times P-GW has reported TAI_CHANGE (26) event trigger to PCRF.
- ECGI Change - Displays the total number of times P-GW has reported ECGI_CHANGE (27) event trigger to PCRF.

Location Based Local-Policy Rule Enforcement

This section describes the overview and implementation of Location-based Local-Policy (LP) Rule Enforcement feature.

This section discusses the following topics for this feature:

- [Feature Description, on page 294](#)
- [How it Works, on page 295](#)
- [Configuring Location Based Local Policy Rule Enforcement Feature, on page 296](#)
- [Monitoring and Troubleshooting the Location Based LP Rule Enforcement Feature, on page 298](#)

Feature Description

This feature is introduced to activate different predefined rules for different E-UTRAN Cell Global Identifiers (ECGIs) when the subscriber is connected to a corporate APN. The subscriber has to explicitly bring down the connection with the corporate APN and re-establish session with Internet APN when out of the company area. It is assumed that corporate APN does not use PCRF and use only Local-Policy. In this case, all calls matching the APN is directed to the Local-Policy.



Important

For this feature to work, the license to activate Local-Policy must be configured. For more information on the licensing requirements, contact your local Cisco account representative.

To activate different predefined rules for ECGI, Local-Policy configurations are enhanced to support:

- Configuration and validation of a set of ECGIs
- Installation of ECGI_CHANGE event trigger through Change Reporting Action (CRA) event
- Detection of ECGI_CHANGE event

This feature supports the following actions to be applied based on the ECGI match with Local-Policy ruledef condition:

- Enable a redirect rule on ECGI_CHANGE event notification when the ECGI belongs to a certain group
- Enable a wild card rule for any other ECGIs

Relationships to Other Features

This feature has a dependency on TAI and ECGI Change Reporting feature, which provides a framework to report ECGI-Change from session manager module to IMSA/Local-Policy module.

How it Works

This section describes how the Local Policy Rule selection and enforcement happens based on ECGI-CHANGE event trigger.

Flows

The following figure describes how the ECGI-CHANGE event is being handled in Local-Policy, MME and P-GW.

Figure 31: ECGI-CHANGE Event Handling

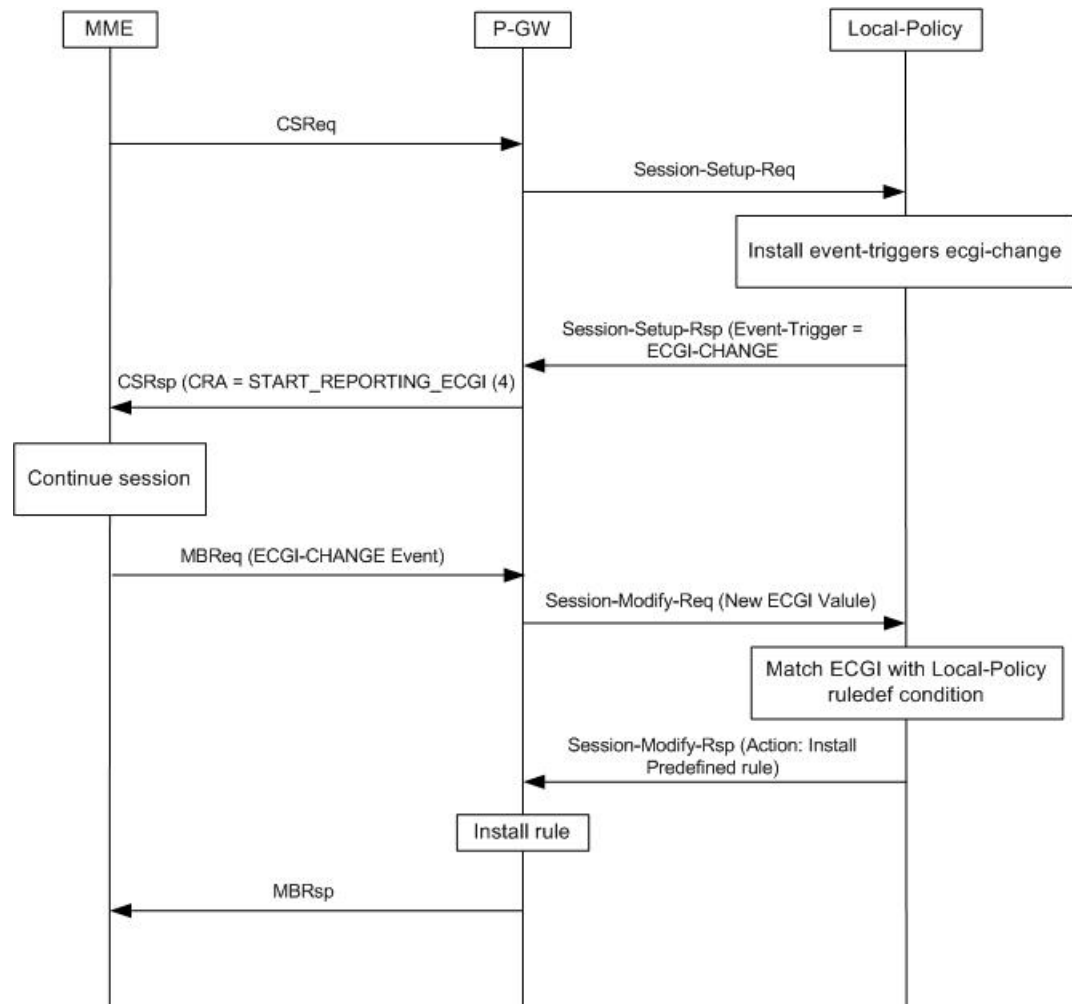

412867

When a new call is established the ECGI-CHANGE event trigger is sent from Local-Policy. P-GW requests the MME for ECGI reporting by sending CRA of 4 in Create Session Response (CSRsp). MME informs the P-GW of ECGI Change through Change Notification request/Modify Bearer Request (MBReq). Local-Policy configuration at P-GW will handle the ECGI-CHANGE event and take appropriate action based on the ECGI group to which the new ECGI belongs. One action could be to activate a certain redirect rule when ECGI belongs to a certain group, and other action could be to enable a wildcard rule for any other ECGI.

Limitations

This section identifies the known limitations of this feature.

- ECGI Change detection and triggering is a pre-requisite for this feature.
- This feature is supported for Local-Policy-only (lp-only) mode wherein, all requests and responses within a particular APN directly go to Local-Policy without contacting PCRF. That is, this feature does not work in Local-Policy fallback mode and dual mode wherein both PCRF and Local-Policy co-exist.

Configuring Location Based Local Policy Rule Enforcement Feature

This section provides the configuration of parameters within Local-Policy to enable rule enforcement based on ECGI-Change event notification.

Configuring ECGI Change Trigger

Use the following configuration to install ECGI-Change trigger from local-policy.

```
configure
  local-policy-service service_name
    actiondef actiondef_name
      action priority priority event-triggers ecgi-change
    exit
  eventbase default
    rule priority priority event new-call ruledef ruledef_name actiondef
actiondef_name [ continue ]
  end
```

Notes:

- **priority** *priority*: Specifies a priority for the specified action. *priority* must be unique and an integer from 1 to 2048.
- **ecgi-change**: This keyword specifies to install ECGI-CHANGE event trigger. If enabled, ECGI-CHANGE event trigger is sent from local-policy.
- This CLI command is configured in local-policy if operator wants to enable ECGI-Change notification in MME by sending a CRA value.

Applying Rules for ECGI-Change Event

Use the following configuration to enable ECGI Change detection and take specific action for ECGI-CHANGE event reported by MME.

```
configure
  local-policy-service service_name
    eventbase eventbase_name
      rule priority priority event ecgi-change ruledef ruledef_name
actiondef actiondef_name [ continue ]
  end
```

Notes:

- **priority** *priority*: Specifies a priority for the specified rule. *priority* must be unique and an integer from 1 to 2048.

- **ruledef** *ruledef_name*: Associates the rule with a specific ruledef. *ruledef_name* must be an existing ruledef within this local QoS policy service.
- **actiondef** *actiondef_name*: Associates the rule with a specific actiondef. *actiondef_name* must be an existing actiondef within this local QoS policy service expressed as an alphanumeric string of 1 through 63 characters.
- **ecgi-change**: Enables a new event to detect ECGI-CHANGE and applies specific action for the ECGI-CHANGE event as defined in actiondef configuration.
- **continue**: Subsequent rules are also matched; otherwise, rule evaluation is terminated on first match.

Enforcing Local Policy Rule based on ECGI Value

Use the following configuration to apply rules based on the ECGI value received in ECGI-Change event notification by MME.

```
configure
  local-policy-service service_name
    ruledef ruledef_name
      condition priority priority ecgi mcc mcc_num mnc mnc_num eci { eq |
ge | gt | le | lt | match | ne | nomatch } regex | string_value | int_value |
set }
    end
```

Notes:

- **priority** *priority*: Specifies a priority for the specified condition. *priority* must be unique and an integer from 1 to 2048.
- **ecgi** *mcc* *mcc_num* *mnc* *mnc_num* *eci*: Configures ECGI with values for MCC, MNC and ECI.
 - **mcc** *mcc_num* : MCC is a three digit number between 001 to 999. It is a string of size 3 to 3.
 - **mnc** *mnc_num* : MNC is a two/three digit number between 01 to 999. It is a string of size 2 to 3.
 - **eci**: ECI is a hexadecimal number between 0x1 to 0xfffffff. It is a string of size 1 to 7.
- This CLI command is configured in local-policy if operator wants to take specific action based on certain ECGI value received in ECGI-Change event notification by MME.

Verifying the Location Based LP Rule Enforcement Configuration

Use the following command to verify the configuration of this feature.

```
show configuration context
```



Important

This feature is supported for Local-Policy-only mode wherein, all requests and responses within a particular APN directly go to Local-Policy without contacting PCRF.

Here is an example configuration for this feature.

```
configure
  context source
```

```

    apn corporate-apn
      ims-auth-service LocalPolicy_1
    exit
  exit
end

configure
  local-policy-service LocalPolicy_1
    ruledef any-imsi
      condition priority 1 imsi match *
    exit
    ruledef ecgi-group
      condition priority 1 ecgi mcc 123 mnc 456 eci eq ffff
    exit
    actiondef ecgi-trigger
      action priority 1 event-triggers ecgi-change
    exit
    actiondef ecgi-redirect-rule
      action priority 1 activate-rule name rule-1
    exit
    eventbase default
      rule priority 1 event new-call ruledef any-imsi actiondef ecgi-trigger

      rule priority 2 event ecgi-change ruledef ecgi-group actiondef
ecgi-redirect-rule
      rule priority 3 event location-change ruledef ecgi-group actiondef
ecgi-redirect-rule
    exit
  exit
end

```

Monitoring and Troubleshooting the Location Based LP Rule Enforcement Feature

This section provides information regarding show commands and/or their outputs in support of the Location Based Local Policy Rule Enforcement feature.

Use the following CLI commands to troubleshoot if any issue is encountered with this feature.

```

show configuration context

logging filter active facility local-policy level debug

show local-policy statistics

show active-charging sessions full

```

show local-policy statistics summary

The following statistics are added to the output of this show command to support the ECGI-CHANGE event trigger installation:

- Event Statistics:
 - ECGI Change - Displays the number of ECGI-CHANGE event triggers that has been received by Local-Policy.

- Variable Matching Statistics
 - ECGI - Displays the number of times the ECGI is matched and the specific action is applied based on the event.

Gx Support for GTP based S2a/S2b

In releases prior to 18, for WiFi integration in P-GW, Gx support was already available for GTP based S2a/S2, but the implementation was specific to a particular customer.

In 18 and later releases, the Gx support for GTP based S2a/S2 interface is extended to all customers. This implementation is in compliance with standard Rel.8 Non-3GPP specification part of 29.212, along with C3-101419 C3-110338 C3-110225 C3-120852 C3-130321 C3-131222 CRs from Rel.10/Rel.11.

As part of this enhancement, the following changes are introduced:

- AVP support for TWAN ID is provided
- TWAN-ID is added to r8-gx-standard dictionary

Gx-based Virtual APN Selection

This section describes the overview and implementation of Gx based Virtual APN Selection feature.

This section discusses the following topics for this feature:

- [Feature Description, on page 299](#)
- [Configuring Gx based Virtual APN Selection Feature , on page 300](#)
- [Monitoring and Troubleshooting the Gx based Virtual APN Selection, on page 300](#)

Feature Description

Overview

The current implementation supports Virtual APN (VAPN) Selection through RADIUS or local configuration. In Release 19, ASR 5500 uses PCRF and Gx interface for Virtual APN selection to achieve signaling reduction.

A new supported feature "**virtual-apn**" with feature bit set to 4 is added to the IMSA configuration. This configuration enables Gx based Virtual APN Selection feature for a given IMS authorization service. When this configuration is enabled at P-GW/GGSN, then P-GW/GGSN advertises this feature to PCRF through the Supported-Features AVP in CCR-I. When the VAPN is selected, then the PCRF rejects the CCR-I message with the Experimental-Result-Code AVP set to 5999 (DIAMETER_GX_APN_CHANGE), and sends a new APN through the Called-Station-Id AVP in CCA-I message. The existing call is then disconnected and reestablished with the new virtual APN. Note that the Experimental Result Code 5999 will have the Cisco Vendor ID.



Important

Enabling this feature might have CPU impact (depending on the number of calls using this feature).

License Requirements

This feature requires a valid license to be installed prior to configuring this feature. Contact your Cisco account representative for detailed information on specific licensing requirements. For information on installing and verifying licenses, refer to the *Managing License Keys* section of the *Software Management Operations* chapter in the *System Administration Guide*.

Limitations

The following are the limitations of this feature:

- Virtual APN supported feature negotiation, Experimental Result Code (5999), Called-Station-Id AVP should be received to establish the call with new virtual APN. When any one of conditions is not met then the call will be terminated.
- Failure-handling will not be taken into account for 5999 result-code when received in the CCA-I message.
- When the Experimental Result Code 5999 is received in the CCA-U then failure-handling action will be taken.
- If the Called-Station-Id AVP is received in CCA-U or CCA-T, then the AVP will be ignored.
- If virtual-apn is received in local-policy initiated initial message then the call will be terminated.
- When PCRF repeatedly sends the same virtual-apn, then the call will be terminated.

Configuring Gx based Virtual APN Selection Feature

The following section provides the configuration commands to enable the Gx based Virtual APN Selection.

```
configure
  context context_name
    ims-auth-service service_name
      policy-control
        diameter encode-supported-features virtual-apn
      end
```

Notes:

- **virtual-apn**: This keyword enables configuration of Gx-based Virtual APN Selection feature. By default, this feature is disabled.
- This keyword is license dependent. For more information, contact your Cisco account representative.

Verifying the Gx based Virtual APN Configuration

Use the following command in Exec mode to display whether the Gx based Virtual APN Selection feature is configured as part of the Supported-Features AVP.

```
show ims-authorization sessions full all
```

The "Negotiated Supported Features" field in this show command output displays the configuration status. This supported feature is displayed only when the feature license is configured.

Monitoring and Troubleshooting the Gx based Virtual APN Selection

This section provides information regarding show commands and/or their outputs in support of this feature.

show ims-authorization policy-control statistics

The following field has been added to the output of this show command to track the number of times the PCRF sends the Diameter Experimental Result Code (5999) when a new virtual APN is selected.

- **Gx APN Change**

For descriptions of this statistics, see the *Statistics and Counters Reference* guide.

Debugging Statistics

Use the following command to debug the Gx based Virtual APN calls.

```
show session subsystem facility sessmgr debug-info
```

This command displays the detailed statistics associated with the Gx-based VAPN feature. For example, number of Gx VAPN received, number of AAAMGR/SGX/DHCP messages after enabling Gx VAPN, and Gx VAPN calls setup time.

Bulk Statistics for Gx based Virtual APN Selection Feature

IMSA Schema

The following new bulk statistic variable is added to the IMSA schema to track the number of times the PCRF sends the Diameter Experimental Result Code (5999) when a new virtual APN is selected.

- **dpca-expres-gx-apn-change**

For descriptions of this variable, see the *Statistics and Counters Reference* guide.

System Schema

The following new disconnect reason is added to the System schema to track the number of times a P-GW/GGSN/SAEGW session was disconnected due to validation failure of virtual APN received from PCRF.

- **gx-vapn-selection-failed (618)**

For descriptions of this variable, see the *Statistics and Counters Reference* guide.

Graceful Handling of RAR from Different Peers

In StarOS Gx architecture, every Diameter session is associated with a Primary and a Secondary peer when host select is configured at the IMSA service. The behavior for processing RAR prior to release 20 is as follows:

- If the RAR is received from the Primary peer for the session, the RAR is responded using the Primary peer connection.
- If the RAR is received from a Secondary peer for the session, host-switch takes effect. This results in the RAA (and any further session signaling) happening via the Secondary peer.
- If the RAR is received via a third peer which is neither the Primary nor the Secondary peer for the session, the RAR is dropped.

In certain networks where PCRF and PCEF are connected through multiple DRAs the PCRF may select the DRA in a round-robin fashion and the RAR for a session may come from a peer which is neither Primary nor Secondary. In order to handle such a scenario, the ability to respond to the RAR received from a non-primary and non-secondary peer was added. In this case, the RAR is answered via the peer from which RAR was received. However any future signaling for the session will still occur via the previously communicating peer. If the RAR is received via the secondary peer, the host-switch occurs and the behavior remains unchanged. In order to be able to process the RAR from a third peer, that peer must be configured in the Diameter endpoint configuration. Further, this issue is seen only when host select is configured at IMSA service. When the host selection happens at endpoint level, this issue is not seen.

Assume there are three DRAs and they are configured as shown in the sample configuration below:

```
configure
  context test
    diameter endpoint Gx
      ...
      peer DRA1 realm realmName address 192.168.23.3
      peer DRA2 realm realmName address 192.168.23.3 port 3869
      peer DRA3 realm realmName address 192.168.23.3 port 3870
      exit
    ims-auth-service imsa-Gx
      policy-control
        diameter host-select row-precedence 1 table 1 host DRA1
        secondary host DRA2
      end
    end
```

Without the feature, when RAR is received from DRA3, it is rejected. With the feature enabled, RAR from DRA3 is responded via DRA3 only and Peer switch will not occur in this case and subsequent messaging will be sent through DRA1 or DRA2 if any prior peer switch had happened.

Limitations

This section identifies the limitations for this feature.

- RAR will be rejected when received from different origin host.
- RAR will be rejected when received from a DRA not configured in Diameter endpoint.

NetLoc Feature Enhancement

This feature adds compliance with 3GPP standard R13 version to the existing NetLoc feature functionality.

Feature Description



Important

This is a license controlled feature. Netloc feature license key is required to be enabled. Contact your Cisco account representative for information on how to obtain a license.

This feature adds compliance with 3GPP standard R13 version to the existing NetLoc feature functionality. Using this NetLoc feature, the IMS network can retrieve location information of the UE from the access or LTE network. This enhances the location related functionality and charging based on the location information.

This feature introduces the following behavior changes:

- Assuming that NetLoc feature is enabled on chassis and Access Network Information (ANI-45) Event trigger is installed, following behavior changes have been introduced:

Table 35: Gx Interface Behavior Change Towards PCRF

PCRF Gx Interface Interaction	Access Side Interaction	ULI & MS TZ Behavior Before 21.1 Release(Standard Gx-R8/Custom15 (AT&T))	ULI & MS TZ Behavior Change(Standard Gx-R8/Custom15 (AT&T))
RAI AVP with '0 - ULI' is received in the charging rule install request.	Create Bearer Response is received with only New ULI parameter.	Create Bearer Response is received with only New ULI parameter.	No change in the behavior.
RAI AVP with '0 - ULI' is received in the charging rule install request.	Create Bearer Response is received with No ULI parameter.	Old ULI parameter is sent towards the PCRF in the CCR-U message.	PLMN-id in 3GPP-SGSN-MCC-MNC AVP is sent towards the PCRF.
RAI AVP with '0 - ULI' is received in the charging rule modify request.	Update Bearer Response is received with only New ULI parameter.	New ULI parameter is sent towards the PCRF in the CCR-U message.	No change in the behavior.
RAI AVP with '0 - ULI' is received in the charging rule Modify request.	Update Bearer Response is received with No ULI parameter.	Old ULI parameter is sent towards the PCRF in the CCR-U message.	PLMN-id in 3GPP-SGSN-MCC-MNC AVP is sent towards the PCRF.
RAI AVP with '0 - ULI' is received in the charging rule modify request.	Delete Bearer Response is received with only New ULI parameter and No MS TZ parameter.	New ULI and old MS TZ parameters are sent towards the PCRF in the CCR-U message.	Only New ULI is sent towards the PCRF in the CCR-U message.
RAI AVP with '0 - ULI' is received in the charging rule Modify request.	Delete Bearer Response is received with No ULI parameter and No MS TZ parameter.	Old ULI and old MS TZ parameters are sent towards the PCRF in the CCR-U message.	PLMN-id in the 3GPP-SGSN-MCC-MNC AVP is sent towards the PCRF.
RAI AVP with '1 -MSTZ' is received in the charging rule install request.	Create Bearer Response is received with only new MS TZ parameter.	New MS TZ parameter is sent towards the PCRF in the CCR-U message.	No change in the behavior.
RAI AVP with '1 - MSTZ' is received in the charging rule install request.	Create Bearer Response is received with No MS TZ parameter.	Old MS TZ parameter is sent towards the PCRF in the CCR-U message.	No change in the behavior.

PCRF Gx Interface Interaction	Access Side Interaction	ULI & MS TZ Behavior Before 21.1 Release(Standard Gx-R8/Custom15 (AT&T))	ULI & MS TZ Behavior Change(Standard Gx-R8/Custom15 (AT&T))
RAI AVP with '1-MSTZ' is received in the charging rule modify request.	Update Bearer Response is received with only New MS TZ parameter.	New MS TZ parameter is sent towards the PCRF in the CCR-U message.	No change in the behavior.
RAI AVP with '1-MSTZ' is received in the charging rule Modify request.	Update Bearer Response is received with No MS TZ parameter.	Old MS TZ parameter is sent towards the PCRF in the CCR-U message.	No change in the behavior.
RAI AVP with '1-MSTZ' is received in the charging rule modify request.	Delete Bearer Response is received with only New MS TZ parameter.	Old ULI and New MS TZ parameters are sent towards the PCRF in the CCR-U message.	Only New MS TZ is sent towards the PCRF in the CCR-U message.
RAI AVP with '1-MSTZ' is received in the charging rule Modify request.	Delete Bearer Response is received with No MS TZ parameter.	New ULI and old MS TZ parameters are sent towards the PCRF in the CCR-U message.	Only old MS TZ is sent towards the PCRF.
Nothing is received.	Delete Session Request is received with New ULI and New MS TZ parameters.	New ULI and New MS TZ parameters are sent towards the PCRF in the CCR-T message.	No change in the behavior.
Nothing is received.	Delete Session Request is received with New ULI and No MS TZ parameter.	New ULI and Old MS TZ parameters are sent towards the PCRF in the CCR-T message.	No change in the behavior.
Nothing is received.	Delete Session Request is received with No ULI and No MS TZ parameter.	Old ULI and Old MS TZ parameters are sent towards the PCRF in the CCR-T message.	No change in the behavior.



Important ULI and ULI timestamp is considered as paired. If the ULI timestamp is forwarded, it is forwarded and received with the ULI. If the ULI is received and the ULI timestamp is not received, then that P-GW does not forward the old timestamp.

- Inclusion of AVP support of NETLOC-ACCESS-NOT-SUPPORTED on Gx interface. This inclusion of AVP is based on the below conditions:
 - RAT type is other than E-UTRAN, UTRAN, WCDMA, GPRS, GERAN, and W-LAN
 - IP CAN type is other than 3GPP EPS, GPRS, and non 3GPP EPS

- Re-Auth-Request is received with Required-Access-Info AVP.
- NetLoc feature is enabled on the chassis.
- Event-Trigger ACCESS_NETWORK_INFO_REPORT (45) is installed.

Before Release 21.1 Behavior (Standard Gx-R8/Custom15(AT&T))	New Behavior(Standard Gx-R8/Custom15(AT&T))
Earlier, if IP-CAN type or RAT type was not support NETLOC, P-GW(PCEF) ignored RAI received from the PCRF.	New AVP NetLoc-Access-Support has been added in the Re-Auth-Answer message in the R8-Gx-standard and the Custom15 Gx Dictionary.

• **Table 36: Behavior Change Regarding LastUserLocationInformation AVP and LastMSTimeZone AVP**

P-GW CDR Behavior	Post 21.1 Release, Behavior in Custom 35/Custom 24/Custom 48 Dictionaries	Custom52 Dictionary (standard compliance new dictionary)/ Custom 35 Dictionary (Customer Specific)
ULI is received in Delete Bearer Command/Delete Bearer Request /Delete Session Request.	ULI was not part of P-GW CDR generation.	ULI is recorded as LastUserLocationInformation AVP in the P-GW CDR generation. (AVP is not controlled using the CLI command.)
MS TZ is received in the Delete Bearer Command/Delete Bearer Request /Delete Session Request.	MS TZ was not part of P-GW CDR generation.	MS TZ is recorded as LastMSTimeZone AVP in the P-GW CDR generation. CDR is released as Normal Release. MS TZ is not detected in this case as full trigger and does not release extra CDR with MS TZ changes cause. AVP is not controlled using the CLI command.
S-GW CDR behavior	Post 21.1 Release behavior in Custom 35/Custom 24 Dictionary	Custom24 Dictionary (standard dictionary)/ Custom 35 Dictionary (AT&T)
ULI is received in Delete Bearer Command/Delete Bearer Request /Delete Session Request.	ULI was not part of CDR generation.	ULI is Recorded as LastUserLocationInformation AVP in the S-GW CDR generation. The attribute is controlled using a CLI command.

MS TZ is received in Delete Bearer Command/Delete Bearer Request /Delete Session Request.	MS TZ was not part of CDR generation.	MS TZ is Recorded as LastMSTimeZone AVP in S-GW CDR generation. The attribute is controlled using a CLI command. CDR is released as Normal Release. MS TZ is not detected in this case as full trigger and does not release extra CDR with MS TZ changes cause.
---	---------------------------------------	---

Limitations

1. This feature enhancement is applicable only for S-GW, P-GW, and SAEGW. For GGSN ad SGSN, there is no change in the behavior of the NetLoc feature.
2. The attributes **Last-MS-Timezone** and **Last ULI attributes** have been added in the dictionaries custom24 and custom35 for S-GW CDR generation only.
3. The keywords **last-ms-timezone** and **last-uli** added to the CLI command **gtp attribute** are applicable and limited to only S-GW CDR generation.
4. **Last-MS-Timezone** and **Last ULI attributes** added in dictionary custom35 (customer specific dictionary) and custom52 (3GPP R13 standard compliance) are applicable and limited to P-GW CDR generation only. These attributes are not CLI controlled.

Command Changes

gtp attribute

This CLI command allows the specification of the optional attributes to be present in the Call Detail Records (CDRs) that the GPRS/PDN/UMTS access gateway generates. It also defines that how the information is presented in CDRs by encoding the attribute field values. The keywords **last-ms-timezone** and **last-uli** have been added to this CLI command to control attribute while CDR generation.



Important

The keywords added are applicable only for S-GW CDR. They are not applicable for P-GW CDR.

```

configure
  context <context_name>
    gtp group group_name
      gtp attribute { last-ms-timezone | last-uli | .. }
      [no | default ] gtp attribute { last-ms-timezone | last-uli |
.. }
    end

```

Notes:

- **no:** Removes the configured GTPP attributes from the CDRs.
- **default:** Sets the default GTPP attributes in the generated CDRs. It also sets the default presentation of attribute values in generated CDRs.

- **last-ms-timezone:** Sets the "Last MS-Timezone" in the CDR field. This option would be disabled when the default option is used.
- **last-uli:** Sets the "Last ULI" in the CDR field. This option would be disabled when the default option is used.

Performance Indicator Changes

show configuration

This command has been modified to display the following output:

- Last-MS-Timezone present
- Last-User Location Information present

show gtp group name *group_name*

This command has been modified to display the following output:

```
Last-MS-Timezone present: yes
Last-User Location Information present:
yes
```

RAN-NAS Cause Code Feature Enhancement

This chapter describes the RAN-NAS Cause Code Feature Enhancement.

Feature Description



Important

This is a license controlled feature. You must enable the existing license of NPLI. Contact your Cisco account representative for information on how to obtain a license.

This feature introduces support for 3GPP RAN/NAS cause code IE for "Failed Create Bearer Response", "Failed Updated Bearer Response", and "Delete Bearer Response" at the Gx interface, the P-GW, and S-GW CDRs. This will enable the operator to get detailed RAN/NAS release cause code information from the access network. RAN/NAS cause can be received from the access side in either of the following messages:

- Failed Create Bearer Response
- Failed Update Bearer Response
- Delete Session Request
- Delete Bearer Response
- Delete Bearer Command

This support of 3GPP Release 12 RAN/NAS cause IE on the S4, S11, S5, and S8 interfaces exists for "Delete Session Request" and "Delete Bearer" command through private extension as well as Standard IE for customer specific dictionaries Gx- dpca-custom15 and Gz-Custom35.

However, RAN/NAS cause received in the "ERAB creation Failure", "ERAB modification Failure", and "ERAB release indication" messages were not processed at the S-GW and P-GW. Hence, it was also not forwarded to the PCRF by P-GW neither populated in the P-GW and S-GW CDRs. With this feature enhancement, support has been added to process the RAN/NAS cause codes at the S-GW (S4,S11 interface) and P-GW (S5,S8 interface) for the "Create bearer response", "Update bearer response", and "Delete bearer response". Also, RAN/NAS cause codes will be forwarded to the PCRF by the P-GW and will be populated in the P-GW and S-GW CDRs.

There is no requirement to add the support for the 3GPP Release 12 RAN/NAS cause IE received in the private extension for "Create Bearer Response", "Update Bearer Response", and "Delete Bearer Response". Private extension support for 3GPP Release 12 cause code IE in "Delete Session Request" and "Delete Bearer Command" will continue to be supported.

This feature enhancement introduces the following RAN/NAS cause IE behavior changes at the Gx interface for dpca-custom15 dictionary and at Gz interface for custom35 dictionary.

Table 37: Gx Interface Requirements for RAN/NAS Cause

Message	GTP Cause	Gx Message Carrying RAN-NAS Cause Information
Create Bearer Response	Accepted	RAN/NAS cause is not expected as per 29.274 Table 7.2.4-2. So if it is received, it is ignored and is not forwarded to the PCRF.
	Temporarily rejected due to HO in progress.	RAN/NAS cause with this GTP cause is not applicable as per 29.274 Table C.4. So if received it is ignored and is not forwarded to the PCRF.
	Other GTP Causes	CCR-U
Update Bearer Response	Accepted	RAN/NAS cause is not expected as per 29.274 Table 7.2.16-2. So if it is received, it is ignored and is not forwarded to the PCRF.
	No Resources	CCR-U
	Available	Important If the UE-initiated (MBC) bearer modification fails with the GTP cause "NO RESOURCES AVAILABLE", then P-GW deletes the entire PDN session. In this case, RAN-NAS cause information is forwarded as part of the CCR-T message.
	Context Not Found	If the update bearer response is received with the message level cause as "CONTEXT NOT FOUND", which leads to the PDN deletion, then the RAN-NAS cause information is forwarded as part of the CCR-T message.
	Temporarily rejected due to HO in progress.	RAN/NAS cause with this GTP cause is not applicable as per 29.274 Table C.4. So if this cause is received, it is ignored and is not forwarded to the PCRF.
	Other GTP Causes	CCR-U

Message	GTP Cause	Gx Message Carrying RAN-NAS Cause Information
Delete Bearer Response	Temporarily rejected due to HO in progress	<p>RAN/NAS cause with this GTP cause is not applicable as per 29.274 Table C.4. So if this cause is received, it is ignored and is not forwarded to the PCRF.</p> <p>Important As per existing design of S-GW, if "Delete Bearer Response" is received with GTP cause "Temporarily rejected due to handover/ TAU/ RAU procedure in progress" it changes GTP cause to "Request Accepted" and forwards it to the P-GW. In this case, if RAN/NAS cause is received in the "Delete Bearer Response", S-GW will forward it to the P-GW. And at the P-GW since "Delete Bearer Response" is received with the GTP cause "Request Accepted" hence RAN/NAS cause is forwarded to the PCRF and populated in the P-GW CDR. This behavior will be seen for SAEGW and S-GW + P-GW combination call.</p>
	Accepted / Other GTP CCR-UCauses	<p>Important If RAN/NAS cause is received in the delete bearer response that is initiated by the network through RAR/CCA-U, then P-GW will not send CCR-U to the PCRF to report the RAN/NAS cause.</p> <p>This support is introduced in 29.212 release 13.5 with "Enhance RAN/NAS" feature".</p>

Table 38: Gz Interface Requirements for RAN/NAS Cause

Message	S-GW CDR	P-GW CDR
Delete Session Request	Yes	Yes
Delete Bearer Command	Yes	Yes NOTE: RAN/NAS cause if received in delete bearer response will overwrite the RAN/NAS cause received in delete bearer command
Failed Create Bearer Response	No	No
Failed Update Bearer Response	No	No
Delete Bearer Response	No	Yes

Limitations

Following are the limitations of this feature:

- Support of RAN/NAS cause over S2a and S2b interfaces is not supported.

- Support of RAN/NAS cause information has not been added for standard Gx and Gz dictionaries.
- P-GW processes first two RAN/NAS cause IE (max one RAN and max one NAS) information received from the GTP interface. For example, if the access network misbehaves and sends RAN/NAS cause list with two NAS and one RAN then only first two causes are considered and validated. In this case, these are two NAS causes, only first NAS cause will be populated at the Gx interface and in the CDRs as only one NAS is allowed.
- As per spec 32.251 Table 5.2.3.4.1.1 and Table 5.2.3.4.2.1, there is no trigger to generate the S-GW CDRs and P-GW CDRs for failed create bearer response and failed update bearer response. Hence, RAN/NAS cause received in "Failed Create Bearer" response and "Failed Update Bearer" response will not be sent to the Gz interface.
- In "Delete Bearer" scenario, S-GW CDRs are generated immediately after receiving "Delete Bearer" request. Hence, RAN/NAS cause received in the "Delete Bearer" response is not populated in the S-GW CDRs.
- If RAN/NAS cause is received in the "Delete Bearer" response that is initiated by the network through RAR/CCA-U, P-GW will not send CCR-U to the PCRF to report the RAN/NAS cause. This support is introduced in spec 29.212 release 13.5 with "Enhance RAN/NAS" feature".
- If the RAN-NAS-Cause feature is supported, only RAN/NAS cause is forwarded to PCRF . ANI information will be forwarded only when NetLoc feature is enabled. Below table describes various scenarios,

Scenario	RAN/NAS Cause Behavior	ANI Behavior
IP-CAN Bearer Termination	If the RAN-NAS-Cause feature is supported (If Netloc-ran-nas-cause CLI is configured and Supported-Features = RAN-NAS-CAUSE was asserted in the Gx CCR-I/CCA-I), PCEF will include the received RAN cause and/or the NAS cause due to bearer termination, in the RAN-NAS-Release-Cause AVP included in the Charging-Rule-Report AVP.	ANI information received during bearer termination is populated in the CCR-U, if Required-Access-Info was asserted when one or more of the failed charging rules installation request was received in CCA-U/RAR (If Netloc CLI is configured and Supported-Features = Netloc was asserted in Gx CCR-I/CCA-I).
IP-CAN Session Termination	If the RAN-NAS-Cause feature is supported (If Netloc-ran-nas-cause CLI is configured and Supported-Features = RAN-NAS-CAUSE was asserted in the Gx CCR-I/CCA-I), PCEF will include the received RAN cause and/or the NAS cause due to session termination, in the RAN-NAS-Release-Cause AVP at the command level.	ANI information received during session termination is populated in CCR-T, if Required-Access-Info was asserted when one or more of the failed charging rules installation request was received in the CCA-U/RAR (If Netloc CLI is configured and Supported-Features = Netloc was asserted in the Gx CCR-I/CCA-I).

Scenario	RAN/NAS Cause Behavior	ANI Behavior
PCC Rule Error Handling	If the RAN-NAS-Cause feature is supported (If Netloc-ran-nas-cause CLI is configured and Supported-Features = RAN-NAS-CAUSE was asserted in Gx CCR-I/CCA-I), PCEF will include the received RAN cause and/or the NAS cause due to rule installation/ activation/ modification failure, in the RAN-NAS-Release-Cause AVP included in the Charging-Rule-Report AVP.	ANI information received due to rule installation/activation/modification failure is populated in CCR-U, if Required-Access-Info was asserted when one or more of the failed charging rules installation request was received in CCA-U/RAR (If Netloc CLI is configured and Supported-Features = Netloc was asserted in the Gx CCR-I/CCA-I).

Command Changes

diameter encode-supported-features netloc netloc-ran-nas-cause

The behavior of this CLI command has been modified in this feature enhancement.

Previous Behavior: To enable the RAN/NAS Cause feature, it was mandatory to enable the NetLoc feature. For this, it was mandatory to configure the **netloc** keyword in the CLI command **diameter encode-supported-features netloc netloc-ran-nas-cause** .

New Behavior: Now, you can enable the RAN/NAS feature without configuring the NetLoc feature. This implied that it is not mandatory to configure the **netloc** keyword in the CLI command **diameter encode-supported-features netloc netloc-ran-nas-cause** .

```
configure > context context_name > ims-auth-service service_name > policy-control
diameter encode-supported-features netloc netloc-ran-nas-cause
```

Session Disconnect During Diamproxy-Session ID Mismatch

This section describes how to clear the subscriber sessions that are impacted due to the mismatch in Diamproxy grouping information and Session ID.

This section discusses the following topics for this feature:

- [Feature Description, on page 311](#)
- [Configuring System to Delete Diamproxy-Session ID Mismatched Sessions, on page 312](#)
- [Monitoring and Troubleshooting the Mismatched Session Deletion Feature, on page 313](#)

Feature Description

During rapid back-to-back ICSR switchovers or extensive multiple process failures, the Diameter proxy-Session manager mapping information is not preserved across ICSR pairs. This mismatch in the Diameter proxy-Session ID results in rejection of RAR with 5002 - DIAMETER_UNKNOWN_SESSION_ID cause code. This behavior impacts the VoLTE call setup procedure. Hence, this feature is introduced to clear the subscriber sessions that are impacted due to the mismatch in the Diameter proxy-session manager mapping. New CLI configuration

is provided to control the behavior and new bulk statistic counter is supported to report the Diamproxy-Session ID mismatch.

The bulk statistic counter will be incremented only when session is cleared upon receiving RAR message with 5002 result code and detecting session-ID Diamproxy mapping mismatch. A Delete Bearer Request is sent to S-GW with a Reactivation Requested as the cause code while suppressing the CCR-T from being sent to PCRF. So, the subscriber reattaches immediately without impacting the subsequent VoLTE calls, encountering only one failure instead of manual intervention.



Important This enhancement is applicable only to IMS PDN so that there is a limit of one failure when encountering this situation instead of manual intervention. This is applicable to only the Gx RARs.

Configuring System to Delete Diamproxy-Session ID Mismatched Sessions

The following section provides the configuration commands to enable the system to clear the subscriber sessions that are impacted due to the mismatch in Diamproxy grouping information and Session ID.

Clearing Mismatched Subscriber Sessions

Use the following configuration commands to configure the system to disconnect the subscriber sessions based on signaling trigger when session ID and Diamproxy mismatch is identified.

```
configure
  context context_name
    ims-auth-service service_name
      policy-control
        diameter clear-session sessid-mismatch
  end
```

- **sessid-mismatch**: Clears the session with mismatched session ID. This CLI configuration is optional.
- The default configuration is **no diameter clear-session**. By default, the sessions will not be cleared.

Verifying the Configuration to Delete Mismatched Sessions

Use the following command to verify the configuration status of this feature.

```
show ims-authorization service name service_name
```

service_name must be the name of the IMS Authorization service configured for IMS authentication.

This command displays all the configurations that are enabled within the specified IMS authorization service. The "Session-Id Mismatch Clear Session" field can be used to determine whether this feature is enabled or disabled.

```
[local]st40# show ims-authorization service name service1
Context: test
IMS Authorization Service name: service1
Service State: Enabled
Service Mode: Single Interface Policy and Charging
...
Diameter Policy Control:
Endpoint: gx
Origin-Realm: xyz.com
Dictionary: standard
```



```

Supported Features:
  3gpp-r9
...
Host Selection: Table: 1 Algorithm: Round-Robin
Host Reselection Subscriber Limit: Not Enabled
Host Reselection Interval: Not Enabled
Sgsn Change Reporting: Not Enabled
Session-Id Mismatch Clear Session: Enabled
3GPP R9 Flow Direction Compliance: Not Enabled
Host Selection Table[1]: 1 Row(s)
Precedence: 1
...

```

Monitoring and Troubleshooting the Mismatched Session Deletion Feature

This section provides information regarding show commands and/or their outputs in support of this feature.

The following operations should be performed for any failure related to this feature:

- Verify if the feature is enabled using **show ims-authorization service name** *<service_name>* CLI command. If not enabled, configure the **diameter clear-session sessid-mismatch** CLI command and check if it works.
- Collect the output of **show ims-authorization policy-control statistics debug-info** and **show diameter statistics proxy debug-info** commands and analyze the debug statistics.
- Check the system logs that are reported while deleting the affected sessions. For further analysis, contact Cisco account representative.

show ims-authorization service name

A new field "Session-Id Mismatch Clear Session" is added to the output of this show command to indicate whether this feature is enabled or disabled within the specified IMS authorization service.

IMSA Schema

The following bulk statistic variable is added to this schema to report the Diamproxy-Session ID mismatch.

- **dpcarar-dp-mismatch** - This counter displays the total number of sessions cleared while receiving RAR because of session-ID Diamproxy mapping mismatch.

Support for Negotiating Mission Critical QCI

This section describes the overview and implementation of the Mission Critical QCI Negotiation feature.

This section includes the following topics:

- [Feature Description, on page 314](#)
- [Configuring DPCA for Negotiating Mission Critical QCIs, on page 314](#)
- [Monitoring and Troubleshooting the Mission Critical QCI, on page 315](#)

Feature Description

To support Mission Critical (MC) Push to Talk (PTT) services, a new set of standardized QoS Class Identifiers (QCIs) (65, 66, 69, 70) have been introduced. These are 65-66 (GBR) and 69-70 (non-GBR) network-initiated QCIs defined in 3GPP TS 23.203 v13.6.0 and 3GPP TS 23.401 v13.5.0 specifications. These QCIs are used for Premium Mobile Broadband (PMB)/Public Safety solutions.



Important

The MC-PTT QCI feature requires Wireless Priority Service (WPS) license to be configured. For more information, contact Cisco account representative.

Previous Behavior: The gateway accepted only standard QCIs (1-9) and operator defined QCIs (128-254). If the PCRF sends QCIs with values between 10 and 127, then the gateway rejects the request. MC QCI support was not negotiated with PCRF.

New Behavior: PCRF accepts the new standardized QCI values 69 and 70 for default bearer creation and 65, 66, 69 and 70 for dedicated bearer creation.

For this functionality to work, a new configurable attribute, **mission-critical-qcis**, is introduced under the **diameter encode-supported-features** CLI command. When this CLI option is enabled, the gateway allows configuring MC QCIs as a supported feature and then negotiates the MC-PTT QCI feature with PCRF through Supported-Features AVP.

The gateway rejects the session create request with MC-PTT QCIs when the WPS license is not enabled and Diameter is not configured to negotiate MC-PTT QCI feature, which is part of Supported Feature bit.

For more information on this feature and associated configurations, refer to *P-GW Enhancements for 21.0* section in the *Release Change Reference* guide.

Configuring DPCA for Negotiating Mission Critical QCIs

The following section provides the configuration commands to enable support for MC-PTT QCI feature.

Enabling Mission Critical QCI Feature

Use the following configuration commands to enable MC-PTT QCI feature.

```
configure
  context context_name
    ims-auth-service service_name
      policy-control
        diameter encode-supported-features mission-critical-qcis
      end
    end
```

Notes:

- **mission-critical-qcis:** This keyword enables MC-PTT QCI feature. By default, this feature will not be enabled.
- This keyword can be enabled only if the WPS license is configured. For more information, contact your Cisco account representative.
- To disable the negotiation of this feature, the existing **no diameter encode-supported-features** command needs to be configured. On executing this command, none of the configured supported features will be negotiated with PCRF.

Verifying the Mission Critical QCI Feature Configuration

The **show ims-authorization sessions full all** command generates a display that indicates the configuration status of this feature.

The following sample display is only a portion of the output which shows *mission-critical-qcis* among the Negotiated Supported Features.

```
show ims-authorization sessions full all

CallId: 00004e29           Service Name:  ims-ggsn-auth
  IMSI: 123456789012341
  ....

Negotiated Supported Features:
  3gpp-r8
  mission-critical-qcis
  Bound PCRF Server: 192.1.1.1
  Primary PCRF Server: 192.1.1.1
  Secondary PCRF Server: NA
  ....
```

Monitoring and Troubleshooting the Mission Critical QCI

The following section describes commands available to monitor the Mission Critical QCI feature.

Mission Critical QCI Show Command(s) and/or Outputs

show ims-authorization sessions full all

On running the above mentioned show command, statistics similar to the following are displayed and will indicate if the Mission Critical QCI feature is enabled or not.

```
show ims-authorization sessions full all

CallId: 00004e29           Service Name:  ims-ggsn-auth
  IMSI: 123456789012341
  ....

Negotiated Supported Features:
  3gpp-r8
  mission-critical-qcis
  ....
```

HSS and PCRF-based P-CSCF Restoration Support for WLAN

This section describes the overview and implementation of the HSS-based and PCRF-based P-CSCF Restoration feature for WLAN and EPC networks.

This section includes the following topics:

- [Feature Description, on page 316](#)
- [Configuring the HSS/PCRF-based P-CSCF Restoration, on page 317](#)
- [Monitoring and Troubleshooting the HSS/PCRF-based P-CSCF Restoration, on page 318](#)

Feature Description

The P-CSCF restoration procedures were standardized to minimize the time a UE is unreachable for terminating calls after a P-CSCF failure. In compliance with 3GPP standard Release 13, this feature is developed to include the following P-CSCF restoration mechanisms:

- HSS-based P-CSCF Restoration for Trusted/Untrusted WLAN Access (S2a/S2b)
- PCRF-based P-CSCF Restoration for LTE (S5/S8) and Trusted/Untrusted WLAN Access (S2a/S2b)



Important HSS-based P-CSCF Restoration was supported at P-GW for LTE (S5/S8) prior to StarOS release 21.0.

This feature provides support for both basic and extended P-CSCF Restoration procedures.



Important

The P-CSCF Restoration is a license-controlled feature. A valid feature license must be installed prior to configuring this feature. Contact your Cisco account representative for more information.

- **HSS-based P-CSCF Restoration for WLAN:**

If the P-CSCF restoration mechanism is supported, gateway indicates the restoration support to AAA server through Feature-List AVP in the Authorization Authentication Request (AAR) message sent over S6b interface. The Feature-List AVP is part of the Supported-Features grouped AVP. The Bit 0 of the Feature-List AVP is used to indicate P-CSCF Restoration support for WLAN.

During the P-CSCF Restoration, 3GPP AAA server, after having checked that the PGW supports the HSS-based P-CSCF restoration for WLAN, sends a P-CSCF restoration indication to the P-GW over S6b in a Re-authorization Request (RAR) command. A new Diameter AVP “**RAR-Flags**” is encoded in the RAR message with the Bit 1 set, would indicate to the gateway that the AAA server requests the execution of HSS-based P-CSCF restoration procedures for WLAN.

The existing CLI command **diameter authentication** under AAA Group configuration is extended to encode P-CSCF Restoration feature as part of Supported-Features AVP in the AAR message.



Important Supported-Features will be sent in every AAR message for RAT type WLAN. Feature negotiation is required in every AAR. ReAuth AAR will also do the feature renegotiation.

- **PCRF-based P-CSCF Restoration:**

PCEF supporting P-CSCF restoration mechanism indicates the restoration support in CCR-I message through the Supported-Features AVP. The 24th Bit of the Supported-Feature-List AVP indicates whether this mechanism is supported or not.

The existing CLI command **diameter encode-supported-features** in Policy Control configuration is extended to allow the negotiation of P-CSCF Restoration feature support with PCRF. A new Diameter AVP “**PCSCF-Restoration-Indication**” is introduced to indicate to PCEF that a P-CSCF Restoration is requested. This is achieved by setting AVP value to 0.

Supported-Features AVP is negotiated in CCR-I of all access types (eHRPD, P-GW, GGSN); however, Restoration trigger, if received, is ignored in eHRPD and GGSN.

Limitations

- As per the 3GPP standard specification, if S6b re-authorization request is used for P-CSCF Restoration for WLAN, then for extended P-CSCF Restoration the gateway may send authorization request with only mandatory AVPs. However, in the current implementation, ReAuth used for extended P-CSCF Restoration is a common authorization request of normal ReAuth. It will contain all the AVP of ReAuthorization AAR.

For more information on this feature and associated configurations, refer to *P-GW Enhancements for 21.0* and *SAEGW Enhancements for 21.0* section in the *Release Change Reference* guide.

Configuring the HSS/PCRF-based P-CSCF Restoration

The following section provides the configuration commands to enable support for HSS-based and PCRF-based P-CSCF Restoration feature.

Enabling P-CSCF Restoration Indication on S6b AAA interface

Use the following configuration commands for encoding Supported-Features AVP in the AAR message sent to AAA server via S6b interface.

```
configure
  context context_name
    aaa group group_name
      diameter authentication encode-supported-features
pcscf-restoration-indication
end
```

Notes:

- **encode-supported-features**: Encodes Supported-Features AVP.
- **pcscf-restoration-indication**: Enables the P-CSCF Restoration Indication feature.
- **default encode-supported-features**: Configures the default setting, that is not to send the Supported-Features AVP in AAR message.
- **no encode-supported-features**: Disables the CLI command to not send the Supported-Features AVP.
- The **pcscf-restoration-indication** keyword is license dependent. For more information, contact your Cisco account representative.

Enabling P-CSCF Restoration Indication on Gx interface

Use the following configuration to enable P-CSCF Restoration Indication feature on Gx interface.

```
configure
  context context_name
    ims-auth-service service_name
      policy-control
        diameter encode-supported-features pcscf-restoration-ind
end
```

Notes:

- **pcscf-restoration-ind**: Enables the P-CSCF Restoration Indication feature. This keyword is license dependent. For more information, contact your Cisco account representative. By default, this feature is disabled.
- **default encode-supported-features**: The default configuration is to remove/reset the supported features.
- **no encode-supported-features**: Removes the previously configured supported features.

Verifying the HSS/PCRF-based P-CSCF Restoration

show ims-authorization sessions full all

This command generates a display that indicates the negotiation status of this feature.

The following sample display is only a portion of the output which shows **pcscf-restoration-ind** among the Negotiated Supported Features.

```
show ims-authorization sessions full all

CallId: 00004e22          Service Name:  imsa-Gx
   IMSI: 123456789012341
   ....
Negotiated Supported Features:
  3gpp-r8
  pcscf-restoration-ind
  ....
```

show aaa group all

This show command displays **pcscf-restoration-ind** as part of Supported-Features, if this feature is configured under AAA group.

```
show aaa group all
Group name:  default
Context:    local

Diameter config:
Authentication:
....
Supported-Features:  pcscf-restoration-ind
....
```

Monitoring and Troubleshooting the HSS/PCRF-based P-CSCF Restoration

This section provides information regarding show commands and/or their outputs in support of this feature.

The following operations can be performed for troubleshooting any failure related to this feature:

- Verify if the feature is enabled using **show ims-authorization sessions full all** and **show aaa group all** CLI commands. If not enabled, configure the required CLI commands both under Policy Control and AAA group configuration and check if it works.
- Execute **monitor protocol** command and check if the support for P-CSCF Restoration feature is negotiated in CCR-I and AAR messages. If not, enable the respective CLI commands for this feature to work.
- If the failure is still observed, obtain the following information and contact Cisco account representative for further analysis:

- Monitor protocol log with options 74 (EGTPC) and 75 (App Specific Diameter –Gx/S6b) turned on
- Logs with sessmgr, imsa, and diameter-auth enabled
- Output of **show session disconnect reason** CLI command and the relevant statistics at service level

Show Commands and/or Outputs

show ims-authorization sessions full all

The **Negotiated Supported Features** field in this show command output displays whether or not the P-CSCF Restoration feature is negotiated with PCRF.

This supported feature is displayed only when the feature license is configured.

show aaa group all

The **Supported Features** field in this show command output displays whether or not the P-CSCF Restoration feature is configured as part of the Supported-Features AVP.

This supported feature is displayed only when the feature license is configured.

show license information

If the license to enable the P-CSCF Restoration feature is configured, then the **show license information** command displays the associated license information.

Monitoring Logs

This section provides information on how to monitor the logs that are generated relating to the HSS/PCRF-based P-CSCF Restoration feature.

S6b Diameter Protocol Logs

The **Supported-Features** field is available in AAR/AAA section. The log output generated will appear similar to the following:

```
<<<<OUTBOUND 15:37:23:561 Eventid:92870(5)
....
[V] [M] Supported-Features:
[M] Vendor-Id: 10415
[V] Feature-List-ID: 1
[V] Feature-List: 1
....
INBOUND>>>> 15:37:23:562 Eventid:92871(5)
....
[V] [M] Supported-Features:
[M] Vendor-Id: 10415
[V] Feature-List-ID: 1
[V] Feature-List: 1
....
```

The **RAR-Flags** field is available in RAR section. The log output generated will appear similar to the following:

```
INBOUND>>>> 15:37:43:562 Eventid:92871(5)
....
[M] Re-Auth-Request-Type: AUTHORIZE_ONLY (0)
[V] RAR-Flags: 2
....
```

Gx Diameter Protocol Logs

Under **Supported-Features**, the P-CSCF Restoration **Feature-List** is available in CCR-I/CCA-I section. The output generated will appear similar to the following:

```
<<<<OUTBOUND 13:52:06:117 Eventid:92820(5)
....
[V] [M] Supported-Features:
[M] Vendor-Id: 10415
[V] Feature-List-ID: 1
  [V] Feature-List: 16777217
....
INBOUND>>>>> 13:52:06:118 Eventid:92821(5)
....
[V] [M] Supported-Features:
[M] Vendor-Id: 10415
[V] Feature-List-ID: 1
  [V] Feature-List: 16777216
....
```

The **PCSCF-Restoration-Indication** AVP is available in RAR. The output generated will appear similar to the following:

```
INBOUND>>>>> 13:52:26:119 Eventid:92821(5)
....
[M] Re-Auth-Request-Type: AUTHORIZE_ONLY (0)
[V] PCSCF-Restoration-Indication: 0
....
```

Loop Prevention for Dynamic Rules

Feature Information

Summary Data

Status	New Functionality
Introduced-In Release	21.2
Modified-In Release(s)	Not Applicable
Applicable Product(s)	P-GW
Applicable Platform(s)	ASR 5500
Default Setting	Disabled
Related CDETS ID(s)	CSCvc97345, CSCvd02249
Related Changes in This Release	Not Applicable
Related Documentation	P-GW Administration Guide Command Line Interface Reference

Revision History



Important

Revision history details are not provided for features introduced before release 21.2.

Revision Details	Release	Release Date
New in this release.	21.2	April 27, 2017

Feature Description

When a PCC (Dynamic or Predefined) rule installation fails, the PCEF initiates a CCR-U toward the PCRF to report the failed rule. In case the PCRF responds back with same rule definition, then the rule failure CCR-U is initiated again. This results in a loop of rule failure.

With this feature, gateways have the ability to prevent the loop by reporting the rule install failure to PCRF only once until it is successfully installed.

How It Works

This feature is configurable through a CLI command with which, once a failure is being reported for a subscriber, failure for the same rule is suppressed for that subscriber until it is installed successfully. The rulenames are preserved for a subscriber for which the failures are reported. However, when the condition of the rule failure is rectified for an error (for example, rule definition is added to the configuration and the rule is successfully installed), then the gateway removes the rulename from the failed rules list. So, if the failure for that particular rule occurs again, it is reported to the PCRF.

The failed rulename is not checkpointed and so, if a recovery event like session recovery or an ICSR occurs then the failure of these rules are reported once again.

Configuring Loop Prevention for Dynamic Rules

This section explains the configuration procedures required to enable the feature.

Enabling ACS Policy to Control Loop Prevention

Use the following commands under ACS Configuration Mode to enable or disable the feature which prevents the rule failure loop between PCRF and PCEF:

```
configure
  active-charging service<service_name>
    policy-control report-rule-failure-once
  end
```

Notes:

- When configured, CCR-U will be sent only once for the same rule failure.
- By default, the feature is disabled.
- If previously configured, use the **no policy-control report-rule-failure-once** to disable the feature.

Monitoring and Troubleshooting

The following sections describe commands available to monitor the feature.

Show Commands and Outputs

This section provides information regarding show commands and their outputs for the Loop Prevention for Dynamic Rules feature.

show active-charging service all

The output of the above command has been enhanced to display the status (Enabled/Disabled) of the feature. For example:

```
show active-charging service all
.
.
.
Report Rule Failure Once: Enabled
```

show active-charging subscribers full all

The output of the above command has been enhanced to display the new parameter which shows the total number of rule failures not reported. For example:

```
Callid: 4e21 ACSMgr Card/Cpu: 15/0
Active Charging Service name: acs
Active charging service scheme:
ACSMgr Instance: 1 Number of Sub sessions: 1
Data Sessions Active: 0 Dynamic Routes created: 0
Uplink Bytes: 0 Downlink Bytes: 0
Uplink Packets: 0 Downlink Packets: 0
Accel Packets: 0
FastPath Packets: 0
Total NRSPCA Requests: 0 NRSPCA Req. Succeeded: 0
NRSPCA Req. Failed: 0
Total NRUPC Requests: 0 NRUPC Req. Succeeded: 0
NRUPC Req. Failed: 0
Pending NRSPCA Requests: 0 Pending NRUPC Requests: 0
Total Bound Dynamic Rules: 0 Total Bound Predef. Rules: 0
Data Sessions moved: 0
Bearers Terminated for no rules: 0
Failed Rulebase Install (unknown bearer-id): 0
Failed Rule Install (unknown bearer-id): 0
Total number of rule failures not reported: 1
```

show active-charging subsystem all

The output of the above command has been enhanced to display the new parameter which shows the total number of rule failures not reported. For example:

```
Total ACS Managers: 2
Session Creation Succ: 1 Session Creation Fail: 0
.
.
.
Total Number of Unsolicited Downlink packets received : 0
Total Number of ICMP-HU packets sent : 0
```

```

RADIUS Prepaid Statistics:
Total prepaid sess:          0      Current prepaid sess:      0
Total prepaid auth req:     0      Total prepaid auth success: 0
Total prepaid auth fail:    0      Total prepaid errors:      0
Total number of rule failures not reported :      4

Content Filtering URL Cache Statistics:
Total cached entries:       0
Total hits:                 0      Total misses:              0
.
.
.

```

Separation of Accounting Interim Interval Timer for RADIUS and Diameter Rf

Feature Information

Summary Data

Status	New Functionality
Introduced-In Release	21.2
Modified-In Release(s)	Not Applicable
Applicable Product(s)	eHRPD, GGSN, P-GW
Applicable Platform(s)	ASR 5500
Default Setting	Disabled
Related CDETS ID(s)	CSCvc97616
Related Changes in This Release	Not Applicable
Related Documentation	AAA Interface Administration and Reference Command Line Interface Reference

Revision History



Important

Revision history details are not provided for features introduced before release 21.2.

Revision Details	Release	Release Date
New in this release.	21.2	April 27, 2017

Feature Description

Prior to Release 21.2, the Cisco StarOS platform had a single configuration parameter for sending accounting interim records to RADIUS and Diameter Rf servers. Consequently, it was not possible to send accounting

interim records to RADIUS and Diameter Rf servers with different intervals using the available CLI options. This feature provides a CLI controlled mechanism to have different interim intervals for Diameter Rf and RADIUS accounting applications. Having a separate configurable CLI and interim interval timer values for RADIUS and Diameter Rf servers provides enhanced usability.

How It Works

Currently, the Diameter accounting uses the value configured for RADIUS accounting interim interval. With this feature, configurable through a CLI command, provides an option to separately configure Diameter accounting interim interval for Rf interface. Until Diameter interim CLI is configured with either “no” option or any specific timer value, as a measure for compatibility, RADIUS interim interval value is used for Diameter interim interval. Once Diameter configuration takes effect, any change to RADIUS configuration will not affect Diameter configuration and vice versa. The following table shows the Diameter interim interval values used for different scenarios.

Radius Configuration	Diameter Configuration	Diameter Interim Behavior
No configuration OR Interim Interval: X OR Interim disabled	Interim Interval: Y	Interim Interval: Y Note: X may or may not be same as Y
No configuration OR Interim Interval: X OR Interim disabled	Interim disabled using “No” option	Interim disabled
No configuration OR Interim Interval: X OR Interim disabled	No configuration	Fallback to RADIUS configuration

- Recovery/ICSR behavior: Interim interval configuration used at the time of PDN creation is applicable for entire lifetime of PDN. Recovery/ICSR will not have any impact of existing PDN behavior with regard to Diameter interim interval.
- ICSR Upgrade/Downgrade behavior:
 - Existing session will be recovered based on RADIUS configuration present in old chassis.
 - New session behavior is as per configuration available on newly active chassis.

Limitations

Following are the known limitations of this feature:

1. In case Diameter interim interval CLI is not configured, the P-GW retains the older behavior where Diameter accounting uses the same interim interval value configured for RADIUS accounting.
2. Once diameter accounting configuration is done, it's not possible to go back to the older behavior.

Configuring Diameter Accounting Interim Interval

Use the following commands under AAA Server Group Configuration Mode to configure Diameter accounting interim interval independently from RADIUS accounting interim interval:

```
configure
  context context_name
    aaa group group_name
      diameter accounting interim interval interval_in_seconds
    end
```

Notes:

- *interval_in_seconds*: Specifies the interim interval, and must be in the range of 50 through 40000000.
- If previously configured, use the **no diameter accounting interim interval** to disable the interim accounting messages on Rf interface.
- There is no default Diameter interim interval value.
- In case Diameter interim interval CLI is not configured, the P-GW retains the older behavior where Diameter accounting uses RADIUS interim interval configuration available in AAA server group configuration block.

Monitoring and Troubleshooting

The following sections describe commands available to monitor the feature.

Show Commands and Outputs

This section provides information regarding show commands and their outputs in support of the feature.

```
show aaa group { name <group_name> | all }
```

The output of the above command is modified to display the following new field to show the current configuration for interim interval used for upcoming Diameter Rf accounting sessions:

- Interim-timeout: <50-40000000> or <None>

Following is a sample output where Diameter interim interval is not configured:

```
show aaa group name default
Group name:          default
Context:             pgw

Diameter config:
  Accounting:
```

show configuration [verbose]

```
Request-timeout:      20
Interim-timeout:     None
```

Following is a sample output where Diameter interim interval is configured with the value 900:

```
show aaa group name default
Group name:           default
Context:             pgw

Diameter config:
Accounting:
Request-timeout:     20
Interim-timeout:     900
```

show configuration [verbose]

The output of the above command is modified to display the following new field to show the interval of interim messages in seconds:

- diameter accounting interim interval <value_in_seconds>

Following is a sample output where Diameter interim interval is configured with the value 60:

```
show configuration context isp verbose
config
  context isp
    aaa group default
      diameter accounting interim interval 60
```

Enhancement to OCS Failure Reporting for Gy

Feature Information

Summary Data

Status	Modified Functionality
Introduced-In Release	21.1
Modified-In Release(s)	21.2
Applicable Product(s)	P-GW, SAEGW
Applicable Platform(s)	ASR 5500
Default Setting	Enabled
Related CDETS ID(s)	CSCvc93904
Related Changes in This Release	Not Applicable
Related Documentation	AAA Interface Administration and Reference P-GW Administration Guide SAEGW Administration Guide

Revision History



Important Revision history details are not provided for features introduced before release 21.2.

Revision Details	Release	Release Date
New in this release.	21.2	April 27, 2017

Feature Description

When Cisco-Event-Trigger-Type AVP is installed by PCRF in CCA-I, CCA-U or in RAR messages with value CREDIT_CONTROL_FAILURE (5), then the Cisco-Event grouped AVP is sent by the P-GW to PCRF in CCR-U message with the exact value of OCS failure code. This trigger is sent only when Gy failure occurs and based on the configuration (Credit-Control-Failure-Handling), the ‘Continue’ action is taken and Gy session moves to Offline state.

In releases prior to the implementation of this enhancement, if a failure code was received from OCS in the range of 3000-3999, then Cisco-CC-Failure-Type was sent with the value 3XXX. Similarly, for error codes in the range of 4000-4999 or 5000-5999, Cisco-CC-Failure-Type was reported as 4XXX or 5XXX respectively. With this enhancement, the exact failure code is reported to the PCRF instead of the range. For example, when the Cisco-Event-Trigger-Type is CREDIT_CONTROL_FAILURE (5) and OCS failure code is 3002 in CCA-U, then in CCR-U towards PCRF Cisco-CC-Failure-Type (as part of grouped AVP Cisco-Event) is sent with a value of 3002.

Support Added for RAN/NAS Cause Code for S5/S8 and S2b Interfaces

Feature Information

Summary Data

Status	Modified Functionality
Introduced-In Release	21.1
Modified-In Release(s)	21.2
Applicable Product(s)	P-GW, S-GW, SAEGW
Applicable Platform(s)	ASR 5500
Default Setting	Disabled
Related CDETS ID(s)	CSCuy93748/CSCvc97356
Related Changes in This Release	Not Applicable

Related Documentation	<i>P-GW Administration Guide</i> <i>S-GW Administration Guide</i> <i>SAEGW Administration Guide</i> <i>Command Line Interface Reference</i>
------------------------------	--

Revision History



Important

Revision history details are not provided for features introduced before Release 21.2.

Revision Details	Release	Release Date
New in this release.	21.2	April 27, 2017

Feature Changes



Important

This is a license controlled feature. There are separate licenses for this feature. You must enable the existing license of NPLI or contact your Cisco account representative for information on how to obtain the custom license.

For billing co-ordination at IMS domain and VoWiFi deployments, an operator may require access to the RAN or NAS (or both) release cause code information available at P-CSCF. The P-GW provides detailed RAN/NAS cause information with ANI information received from the access network to the P-GW and further down to the PCRF based on the following events:

- Bearer deactivation (Delete Bearer Response/Delete Bearer Command)
- Session deactivation (Delete Session Request)
- Bearer creation/modification failures (Create/Update Bearer Response with cause as FAILURE)

The IMS network can retrieve detailed RAN and/or NAS release cause codes information from the access network that is used for call performance analysis, user QoE analysis, and proper billing reconciliation. This feature is supported on the S5, S8, Gx, and S2b interfaces.

This feature includes support RAN/NAS cause IE in Create Bearer Response, Update Bearer Response, Delete Bearer Response, Delete Bearer Command, and Delete Session Request. The following table shows the supported protocol type for RAN/NAS cause IE.

Table 39: Protocol Type for RAN/NAS IE

Interface	Supported Protocol Type for RAN/NAS IE
S5/S8	S1AP Cause (1)/EMM Cause (2)/ESM Cause (3)
S2b	Diameter Cause (4)/IKEv2 Cause (5)



Note Any protocol type value that is received apart from the supported protocol type values listed in the table are ignored and not forwarded to the PCRF.

GTP interface Requirements for RAN/NAS Cause

For S5/S8 interface, RAN/NAS cause is supported for the following messages for the dpca-custom8 dictionary.

- Failed Create Bearer Response
- Failed Update Bearer Response
- Delete Session Request
- Delete Bearer Response
- Delete Bearer Command

For S2b interface, RAN/NAS cause is supported for the following messages for the custom dpca-custom8 dictionary:

- Failed Create Bearer Response
- Failed Update Bearer Response
- Delete Session Request

Gx interface Requirements for RAN/NAS Cause

The RAN/NAS cause is added for the custom dpca-custom8 dictionary to ensure that the RAN/NAS cause is populated. The Gx interface behavior to handle RAN/NAS cause is as follows:

Table 40: Gx Interface Requirements for RAN/NAS Cause

Message	GTP Cause	Gx Message Carrying RAN-NAS Cause Information
Create Bearer Response	Accepted	RAN/NAS cause is not expected as per 29.274 Table 7.2.4-2. Therefore, if it is received, it is ignored and not forwarded to the PCRF.
	Temporarily rejected due to HO in progress.	RAN/NAS cause with this GTP cause is not applicable as per 29.274 Table C.4. Therefore, if it is received, it is ignored and not forwarded to the PCRF.
	Other GTP Causes	CCR-U

Message	GTP Cause	Gx Message Carrying RAN-NAS Cause Information
Update Bearer Response	Accepted	RAN/NAS cause is not expected as per 29.274 Table 7.2.16-2. Therefore, if it is received, it is ignored and not forwarded to the PCRF.
	No Resources Available	CCR-U Note If UE-initiated (MBC) bearer modification fails with GTP cause "NO RESOURCES AVAILABLE", P-GW deletes the entire PDN session. In this case, RAN-NAS cause information is forwarded as part of CCR-T message.
	Context Not Found	CCR-U Note If the Update Bearer Response is received with the message level cause as "CONTEXT NOT FOUND", which leads to the PDN deletion, then the RAN-NAS cause information is forwarded as part of the CCR-T message.
	Temporarily rejected due to HO in progress.	RAN/NAS cause with this GTP cause is not applicable as per 29.274 Table C.4. Therefore, if it is received, it is ignored and not forwarded to the PCRF.
	Other GTP Causes	CCR-U

Message	GTP Cause	Gx Message Carrying RAN-NAS Cause Information
Delete Bearer Response	Temporarily rejected due to HO in progress	<p>RAN/NAS cause with this GTP cause is not applicable as per 29.274 Table C.4. Therefore, if it is received, it is ignored and not forwarded to the PCRF.</p> <p>Note</p> <ul style="list-style-type: none"> • If RAN/NAS cause is received in the Delete Bearer Response, which is triggered as a part of the Delete Bearer command and cause as “Request Accepted”, P-GW forwards the RAN/NAS cause (received in Delete Bearer Response) to the PCRF. • If RAN/NAS cause is received in the Delete Bearer command and Delete Bearer Response with HO in progress, the RAN/NAS Cause received in the Delete Bearer command is forwarded to the PCRF. • If RAN/NAS Cause is received in the Delete Bearer command and Delete Bearer Response with Accepted/Other Cause and new RAN/NAS Cause, the new RAN/NAS cause is forwarded to the PCRF.
	Accepted / Other GTP CCR-UCauses	<p>CCR-U</p> <p>Note If RAN/NAS cause is received in the delete bearer response that is initiated through RAR/CCA-U, then P-GW does not send CCR-U to the PCRF to report the RAN/NAS cause.</p> <p>This support is introduced in 29.212 release 13.5 with "Enhance RAN/NAS" feature".</p>
Delete Session Request	Accepted	CCR-T

ANI Behavior Towards PCRF

Section 4.5.6, 4.5.7, 4.5.12 of 3GPP 29.212 v13.4.0 mentions that if the RAN-NAS-Cause feature is supported, the PCEF should provide the available access network information within the 3GPP-User-Location-Info AVP (if available), TWAN-Identifier (if available and Trusted-WLAN feature is supported), User-Location-Info-Time AVP (if available), and 3GPP-MS-TimeZone AVP (if available).

In the earlier releases, the dpca-custom8 dictionary did not support USER-LOCATION-INFO-TIME AVP.

In this release, the USER-LOCATION-INFO-TIME AVP is added to the dpca-custom8 dictionary, which is sent to the PCRF (if available) as a part of ANI. Also, new PROTOCOL-TYPE, 1 to 5 are supported for RAN/NAS. This AVP can be seen in the CCR-U and CCR-T (whenever applicable). Also the new PROTOCOL-TYPE (S1AP Cause, EMM Cause, ESM Cause, IKEv2, DIAMETER) is visible on the Gx interface (if the same is received over the S5/S8/S2b interface).

ANI Behavior for S5/S8 Interface

Along with RAN/NAS cause, P-GW also sends following information to the PCRF, if available, for the dpca-custom8 dictionary:

Table 41: Mapping of GTP IE to ANI AVPs on Gx Interface

GTP IE	Gx AVP
UE Time Zone	3GPP-MS-TimeZone
ULI Timestamp	User-Location-Info-Time
User Location Information	3GPP-User-Location-Info

ANI information is sent to the PCRF irrespective of the event triggers configured when the RAN/NAS feature is enabled.

ANI Behavior for S2b Interface

ANI information is not sent towards PCRF for the dpca-custom8 dictionary. Also, the TWAN-Identifier is not supported as part of ANI for the dpca-custom8 dictionary.

Limitations

Following are the limitations of this feature:

- Support of RAN/NAS cause information is added only for the dpca-custom8 dictionary.
- PGW processes first two RAN/NAS cause IE (max one RAN and max one NAS) information received from the GTP interface. For example, if the access network misbehaves and sends RAN/NAS cause list with two NAS and one RAN then only first two causes are considered and validated. In this case, there are two NAS causes, only first NAS cause is populated at the Gx interface.
- RAN/NAS information is populated only on the Gx interface, no other interface is impacted.

Command Changes

diameter encode-supported-features netloc-ran-nas-cause

Use the existing CLI command, **diameter encode-supported-features netloc-ran-nas-cause** to enable the RAN/NAS cause on each of the S5/S8 and S2b interfaces.

This feature is disabled by default.

To enable this feature, enter the following commands:

```

configure
context ISP1
ims-auth-service MSGx
policy-control
diameter encode-supported-features netloc-ran-nas-cause
end

```



APPENDIX **H**

Gy Interface Support

This chapter provides an overview of the Gy interface and describes how to configure the Gy interface.

Gy interface support is available on the Cisco system running StarOS 9.0 or later releases for the following products:

- GGSN
- HA
- IPSP
- PDSN
- P-GW

It is recommended that before using the procedures in this chapter you select the configuration example that best meets your service model, and configure the required elements for that model as described in the administration guide for the product that you are deploying.

- [Introduction, on page 333](#)
- [Features and Terminology, on page 335](#)
- [Configuring Gy Interface Support, on page 372](#)

Introduction

The Gy interface is the online charging interface between the PCEF/GW (Charging Trigger Function (CTF)) and the Online Charging System (Charging-Data-Function (CDF)).

The Gy interface makes use of the Active Charging Service (ACS) / Enhanced Charging Service (ECS) for real-time content-based charging of data services. It is based on the 3GPP standards and relies on quota allocation. The Online Charging System (OCS) is the Diameter Credit Control server, which provides the online charging data to the PCEF/GW. With Gy, customer traffic can be gated and billed in an online or prepaid style. Both time- and volume-based charging models are supported. In these models differentiated rates can be applied to different services based on ECS shallow- or deep-packet inspection.

In the simplest possible installation, the system will exchange Gy Diameter messages over Diameter TCP links between itself and one prepaid server. For a more robust installation, multiple servers would be used. These servers may optionally share or mirror a single quota database so as to support Gy session failover from one server to the other. For a more scalable installation, a layer of proxies or other Diameter agents can be introduced to provide features such as multi-path message routing or message and session redirection features.

The following figure shows the Gy reference point in the policy and charging architecture.

Figure 32: PCC Logical Architecture

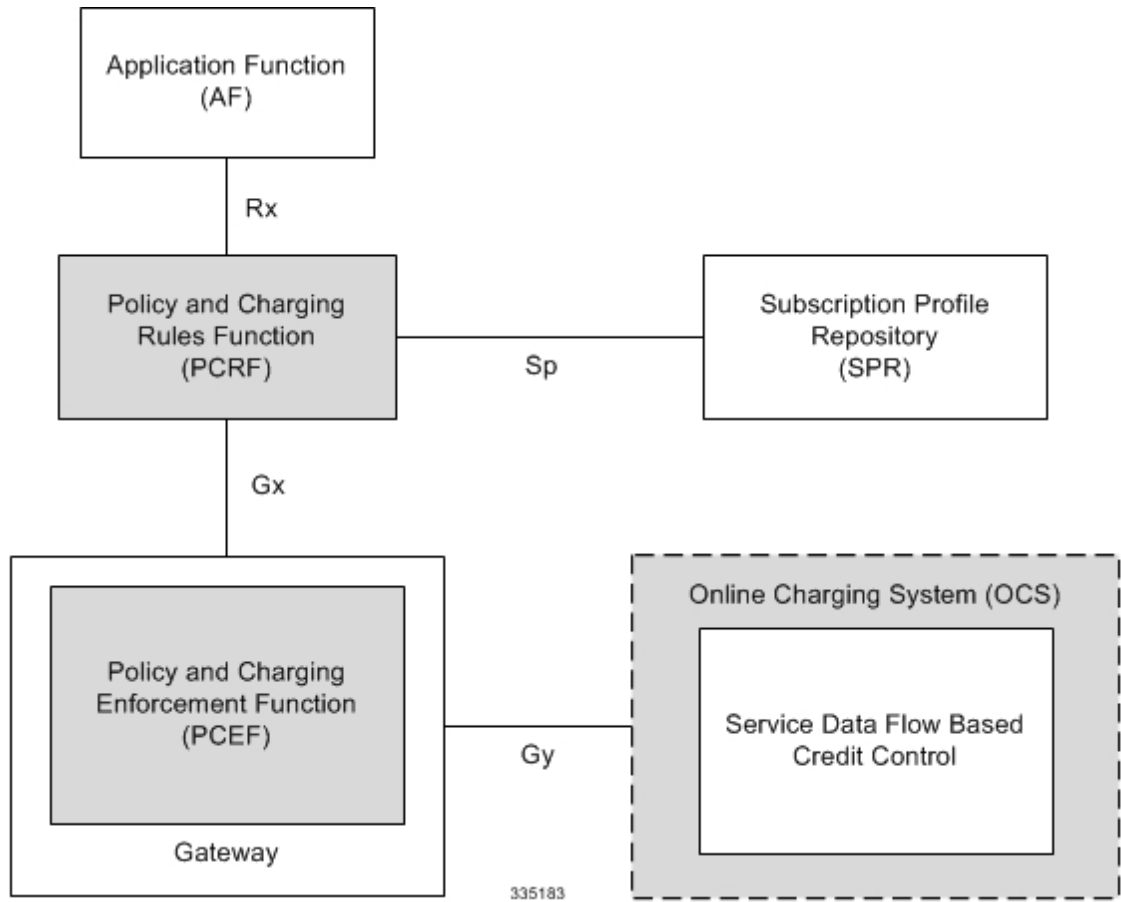

The following figure shows the Gy interface between CTF/Gateway/PCEF/Client running ECS and OCS (CDF/Server). Within the PCEF/GW, the Gy protocol functionality is handled in the DCCA module (at the ECS).

Figure 33: Gy Architecture

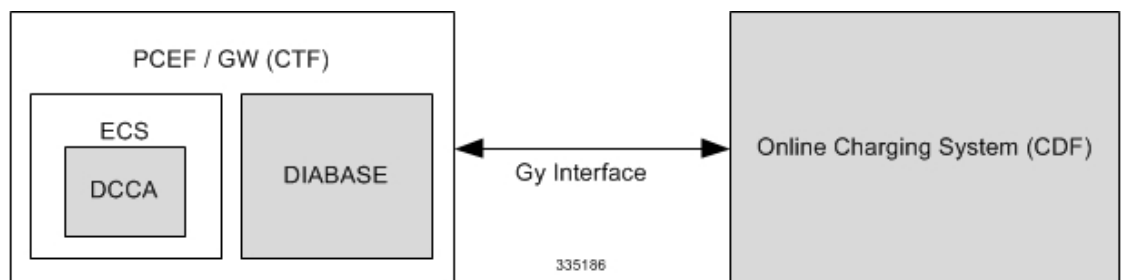

License Requirements

The Gy interface support is a licensed Cisco feature. A separate feature license may be required. Contact your Cisco account representative for detailed information on specific licensing requirements. For information on

installing and verifying licenses, refer to the *Managing License Keys* section of the *Software Management Operations* chapter in the *System Administration Guide*.

Supported Standards

Gy interface support is based on the following standards:

- IETF RFC 4006: Diameter Credit Control Application; August 2005
- 3GPP TS 32.299 V9.6.0 (2010-12) 3rd Generation Partnership Project; Technical Specification Group Services and System Aspects; Telecommunication management; Charging management; Diameter charging applications (Release 9)

Features and Terminology

This section describes features and terminology pertaining to Gy functionality.

Charging Scenarios



Important

Online charging for events ("Immediate Event Charging" and "Event Charging with Reservation") is not supported. Only "Session Charging with Reservation" is supported.

Session Charging with Reservation

Session Charging with Unit Reservation is used for credit control of sessions.

Decentralized Unit Determination and Centralized Rating

In this scenario, the CTF requests the reservation of units prior to session supervision. An account debit operation is carried out following the conclusion of session termination.

Centralized Unit Determination and Centralized Rating

In this scenario, the CTF requests the OCS to reserve units based on the session identifiers specified by the CTF. An account debit operation is carried out following the conclusion of session.

Decentralized Unit Determination and Decentralized Rating



Important

Decentralized Rating is not supported in this release. Decentralized Unit determination is done using CLI configuration.

In this scenario, the CTF requests the OCS to assure the reservation of an amount of the specified number of monetary units from the subscriber's account. An account debit operation that triggers the deduction of the amount from the subscriber's account is carried out following the conclusion of session establishment.

Basic Operations



Important

Immediate Event Charging is not supported in this release. "Reserve Units Request" and "Reserve Units Response" are done for Session Charging and not for Event Charging.

Online credit control uses the basic logical operations "Debit Units" and "Reserve Units".

- Debit Units Request; sent from CTF to OCS: After receiving a service request from the subscriber, the CTF sends a Debit Units Request to the OCS. The CTF may either specify a service identifier (centralised unit determination) or the number of units requested (decentralised unit determination). For refund purpose, the CTF sends a Debit Units Request to the OCS as well.
- Debit Units Response; sent from OCS to CTF: The OCS replies with a Debit Units Response, which informs the CTF of the number of units granted as a result of the Debit Units Request. This includes the case where the number of units granted indicates the permission to render the requested service. For refund purpose, the OCS replies with a Debit Units Response.
- Reserve Units Request; sent from CTF to OCS: Request to reserve a number of units for the service to be provided by an CTF. In case of centralised unit determination, the CTF specifies a service identifier in the Reserve Unit Request, and the OCS determines the number of units requested. In case of decentralised unit determination, the number of units requested is specified by the CTF.
- Reserve Units Response; sent from OCS to CTF: Response from the OCS which informs the CTF of the number of units that were reserved as a result of the "Reserve Units Request".

Session Charging with Unit Reservation (SCUR) use both the "Debit Units" and "Reserve Units" operations. SCUR uses the Session Based Credit Control procedure specified in RFC 4006. In session charging with unit reservation, when the "Debit Units" and "Reserve Units" operations are both needed, they are combined in one message.



Important

Cost-Information, Remaining-Balance, and Low-Balance-Indication AVPs are not supported.

The consumed units are deducted from the subscriber's account after service delivery. Thus, the reserved and consumed units are not necessarily the same. Using this operation, it is also possible for the CTF to modify the current reservation, including the return of previously reserved units.

Re-authorization

The server may specify an idle timeout associated with a granted quota. Alternatively, the client may have a configurable default value. The expiry of that timer triggers a re-authorization request.

Mid-session service events (re-authorization triggers) may affect the rating of the current service usage. The server may instruct the credit control client to re-authorize the quota upon a number of different session related triggers that can affect the rating conditions.

When a re-authorization is trigger, the client reports quota usage. The reason for the quota being reported is notified to the server.

Threshold based Re-authorization Triggers

The server may optionally include an indication to the client of the remaining quota threshold that triggers a quota re-authorization.

Termination Action

The server may specify to the client the behavior on consumption of the final granted units; this is known as termination action.

Diameter Base Protocol

The Diameter Base Protocol maintains the underlying connection between the Diameter Client and the Diameter Server. The connection between the client and server is TCP based. There are a series of message exchanges to check the status of the connection and the capabilities.

- Capabilities Exchange Messages: Capabilities Exchange Messages are exchanged between the diameter peers to know the capabilities of each other and identity of each other.
 - Capabilities Exchange Request (CER): This message is sent from the client to the server to know the capabilities of the server.
 - Capabilities Exchange Answer (CEA): This message is sent from the server to the client in response to the CER message.



Important Acct-Application-Id is not parsed and if sent will be ignored by the PCEF/GW. In case the Result-Code is not DIAMETER_SUCCESS, the connection to the peer is closed.

- Device Watchdog Request (DWR): After the CER/CEA messages are exchanged, if there is no more traffic between peers for a while, to monitor the health of the connection, DWR message is sent from the client. The Device Watchdog timer (Tw) is configurable in PCEF/GW and can vary from 6 through 30 seconds. A very low value will result in duplication of messages. The default value is 30 seconds. On two consecutive expiries of Tw without a DWA, the peer is taken to be down.



Important DWR is sent only after Tw expiry after the last message that came from the server. Say if there is continuous exchange of messages between the peers, DWR might not be sent if (Current Time - Last message received time from server) is less than Tw.

- Device Watchdog Answer (DWA): This is the response to the DWR message from the server. This is used to monitor the connection state.
- Disconnect Peer Request (DPR): This message is sent to the peer to inform to shutdown the connection. PCEF/GW only receives this message. There is no capability currently to send the message to the diameter server.

- **Disconnect Peer Answer (DPA):** This message is the response to the DPR request from the peer. On receiving the DPR, the peer sends DPA and puts the connection state to "DO NOT WANT TO TALK TO YOU" state and there is no way to get the connection back except for reconfiguring the peer again.

A timeout value for retrying the disconnected peer must be provided.

- **Tw Timer Expiry Behavior:** The connection between the client and the server is taken care by the DIABASE application. When two consecutive Tw timers are expired, the peer state is set to idle and the connection is retried to be established. All the active sessions on the connection are then transferred to the secondary connection if one is configured. All new session activations are also tried on the secondary connection.

There is a connection timeout interval, which is also equivalent to Tw timer, wherein after a CER has been sent to the server, if there is no response received while trying to reestablish connection, the connection is closed and the state set to idle.

Diameter Credit Control Application

The Diameter Credit Control Application (DCCA) is a part of the ECS subsystem. For every prepaid customer with Diameter Credit Control enabled, whenever a session comes up, the Diameter server is contacted and quota for the subscriber is fetched.

Quota Behavior

Various forms of quotas are present that can be used to charge the subscriber in an efficient way. Various quota mechanisms provide the end user with a variety of options to choose from and better handling of quotas for the service provider.

Time Quotas

The Credit-Control server can send the CC-Time quota for the subscriber during any of the interrogation of client with it. There are also various mechanisms as discussed below which can be used in conjunction with time quota to derive variety of methods for customer satisfaction.

- **Quota Consumption Time:** The server can optionally indicate to the client that the quota consumption must be stopped after a period equal to the "Quota Consumption Time" in which no packets are received or at session termination, whichever is sooner. The idle period equal to the Quota Consumption Time is included in the reported usage. The quota is consumed normally during gaps in traffic of duration less than or equal to the Quota-Consumption-Time. Quota consumption resumes on receipt of a further packet belonging to the service data flow.

If packets are allowed to flow during a CCR (Update)/CCA exchange, and the Quota-Consumption-Time AVP value in the provided quota is the same as in the previously provided quota, then the Quota-Consumption-Time runs normally through this procedure. For example, if 5 seconds of a 10 second QCT timer have passed when a CCR(U) is triggered, and the CCA(U) returns 2 seconds later, then the QCT timer will expire 3 seconds after the receipt of the CCA and the remaining unaccounted 5 seconds of usage will be recorded against the new quota even though no packets were transmitted with the new quota.

A locally configurable default value in the client can be used if the server does not send the QCT in the CCA.

- **Combinational Quota:** Discrete-Time-Period (DTP) and Continuous-Time-Period (CTP) defines mechanisms that extends and generalize the Quota-Consumption-Time for consuming time-quota.

- Both DTP and CTP uses a "base-time-interval" that is used to create time-envelopes of quota used.
 - Instead of consuming the quota linearly, DTP and CTP consumes the granted quota discretely in chunks of base-time-interval at the start of the each base-time-interval.
 - Selection of one of this algorithm is based on the "Time-Quota-Mechanism" AVP sent by the server in CCA.
 - Reporting usage can also be controlled by Envelope-Reporting AVP sent by the server in CCA during the quota grant. Based on the value of this AVP, the usage can be reported either as the usage per envelope or as usual cumulative usage for that grant.
- Discrete-Time-Period: The base-time-interval defines the length of the Discrete-Time-Period. So each time-envelope corresponds to exactly one Discrete-Time-Period. So when a traffic is detected, an envelope of size equal to Base-Time-Interval is created. The traffic is allowed to pass through the time-envelope. Once the traffic exceeds the base-time-interval another new envelope equal to the base-time-interval is created. This continues till the quota used exceeds the quota grant or reaches the threshold limit for that quota.
 - Continuous-Time-Period: Continuous time period mechanism constructs time envelope out of consecutive base-time intervals in which the traffic occurred up to and including a base time interval which contains no traffic. Therefore the quota consumption continues within the time envelope, if there was traffic in the previous base time interval. After an envelope has closed, then the quota consumption resumes only on the first traffic following the closure of the envelope. The envelope for CTP includes the last base time interval which contains no traffic.

The size of the envelope is not constant as it was in Parking meter. The end of the envelope can only be determined retrospectively.

- Quota Hold Time: The server can specify an idle timeout associated with a granted quota using the Quota-Holding-Time AVP. If no traffic associated with the quota is observed for this time, the client understands that the traffic has stopped and the quota is returned to the server. The client starts the quota holding timer when quota consumption ceases. This is always when traffic ceases, i.e. the timer is re-started at the end of each packet. It applies equally to the granted time quota and to the granted volume quota. The timer is stopped on sending a CCR and re-initialized on receiving a CCA with the previous used value or a new value of Quota-Holding-Time if received.

Alternatively, if this AVP is not present, a locally configurable default value in the client is used. A Quota-Holding-Time value of zero indicates that this mechanism is not used.

- Quota Validity Time: The server can optionally send the validity time for the quota during the interrogation with the client. The Validity-Time AVP is present at the MSCC level and applies equally to the entire quota that is present in that category. The quota gets invalidated at the end of the validity time and a CCR-Update is sent to the server with the Used-Service-Units AVP and the reporting reason as VALIDITY_TIME. The entire quota present in that category will be invalidated upon Quota-Validity-Time expiry and traffic in that category will be passed or dropped depending on the configuration, till a CCA-Update is received with quota for that category.

Validity-Time of zero is invalid. Validity-Time is relative and not absolute.

In releases prior to 17.0, the AVP "SN-Remaining-Service-Unit" was not sent in the CCR-T and CCR-U messages with reporting Reason FINAL when the FUI action was received as Redirect and the granted units was zero in CCA. In 17.0 and later releases, for the Final-Reporting, the AVP "SN-Remaining-Service-Unit" will be encoded.

The "SN-Remaining-Service-Unit" AVP behavior is inherited from "Used-Service-Unit" AVP. This Final-Reporting is missing for the Remaining-Service-Unit AVP, which is now incorporated.

Volume Quota

The server sends the CC-Total-Octets AVP to provide volume quota to the subscriber. DCCA currently supports only CC-Total-Octets AVP, which applies equally to uplink and downlink packets. If the total of uplink and downlink packets exceeds the CC-Total-Octets granted, the quota is assumed to be exhausted.

If CC-Input-Octets and/or CC-Output-Octets is provided, the quota is counted against CC-Input-Octets and/or CC-Output-Octets respectively.



Important

Restricting usages based on CC-Input-Octets and CC-Output-Octets is not supported in this release.

Units Quota

The server can also send a CC-Service-Specific-Units quota which is used to have packets counted as units. The number of units per packet is a configurable option.

Granting Quota

Gy implementation assumes that whenever the CC-Total-Octets AVP is present, volume quota has been granted for both uplink and downlink.

If the Granted-Service-Unit contains no data, Gy treats it as an invalid CCA.

If the values are zero, it is assumed that no quota was granted.

If the AVP contains the sub AVPs without any data, it is assumed to be infinite quota.

Additional parameters relating to a category like QHT, QCT is set for the category after receiving a valid volume or time grant.

If a default quota is configured for the subscriber, and subscriber traffic is received it is counted against the default quota. The default quota is applicable only to the initial request and is not regranted during the course of the session. If subscriber disconnects and reconnects, the default quota will be applied again for the initial request.

Requesting Quota

Quotas for a particular category type can be requested using the Requested-Service-Unit AVP in the CCR. The MSCC is filled with the Rating-Group AVP which corresponds to the category of the traffic and Requested-Service-Unit (RSU) AVP without any data.

The Requested-Service-Unit can contain the CC AVPs used for requesting specific quantity of time or volume grant. Gy CLI can be used to request quota for a category type.

Alternatively quota can also be requested from the server preemptively for a particular category in CCR- I. When the server grants preemptive quota through the Credit control answer response, the quota will be used only when traffic is hit for that category. Quota can be preemptively requested from the Credit Control server from the CLI.

In 12.3 and earlier releases, when no pre-emptive quota request is present in CCR-I, on hitting server unreachable state for initial request, MSCC AVP with RSU is present in the CCR-I on server retries. Release

14.0 onwards, the MSCC AVP is skipped in the CCR-I on server retries. Corresponding quota usage will be reported in the next CCR-U (MSCC AVP with USU and RSU).

Reporting Quota

Quotas are reported to the server for number of reasons including:

- Threshold
- QHT Expiry
- Quota Exhaustion
- Rating Condition Change
- Forced Reauthorization
- Validity Time Expiry
- Final during Termination of Category Instance from Server

For the above cases except for QHT and Final, the Requested-Service-Unit AVP is present in the CCR.

Reporting Reason is present in CCR to let the server know the reason for the reporting of Quota. The Reporting-Reason AVP can be present either in MSCC level or at Used Service Unit (USU) level depending on whether the reason applies to all quotas or to single quota.

When one of these conditions is met, a CCR Update is sent to the server containing a Multiple-Services-Credit-Control AVP(s) indicating the reason for reporting usage in the Reporting-Reason and the appropriate value(s) for Trigger, where appropriate. Where a threshold was reached, the DCCA still has the amount of quota available to it defined by the threshold.

For all other reporting reasons the client discards any remaining quota and either discards future user traffic matching this category or allows user traffic to pass, or buffers traffic according to configuration.

For Reporting-Reason of Rating Condition Change, Gy requires the Trigger Type AVP to be present as part of the CCR to indicate which trigger event caused the reporting and re-authorization request.

For Reporting-Reason of end user service denied, this happens when a category is blacklisted by the credit control server, in this case a CCR-U is sent with used service unit even if the values as zero. When more quota is received from the server for that particular category, the blacklisting is removed.

If a default quota has been set for the subscriber then the usage from the default quota is deducted from the initial GSU received for the subscriber for the Rating Group or Rating Group and Service ID combination.

Default Quota Handling

- If default quota is set to 0, no data is passed/reported.
- If default quota is configured and default quota is not exhausted before OCS responds with quota, traffic is passed. Initial default quota used is counted against initial quota allocated. If quota allocated is less than the actual usage then actual usage is reported and additional quota is requested. If no additional quota is available then traffic is denied.
- If default quota is not exhausted before OCS responds with denial of quota, gateway blocks traffic after OCS response. Gateway will report usage on default quota even in this case in CCR-U (FINAL) or CCR-T.
- If default quota is consumed before OCS responds, if OCS is not declared dead (see definition in use case 1 above) then traffic is blocked until OCS responds.

Thresholds

The Gy client supports the following threshold types:

- Volume-Quota-Threshold
- Time-Quota-Threshold
- Units-Quota-Threshold

A threshold is always associated with a particular quota and a particular quota type. In the Multiple-Services-Credit-Control AVP, the Time-Quota-Threshold, Volume-Quota-Threshold, and Unit-Quota-Threshold are optional AVPs.

They are expressed as unsigned numbers and the units are seconds for time quota, octets for volume quota and units for service specific quota. Once the quota has reached its threshold, a request for more quotas is triggered toward the server. User traffic is still allowed to flow. There is no disruption of traffic as the user still has valid quota.

The Gy sends a CCR-U with a Multiple-Services-Credit-Control AVP containing usage reported in one or more User-Service-Unit AVPs, the Reporting-Reason set to THRESHOLD and the Requested-Service-Unit AVP without data.

When quota of more than one type has been assigned to a category, each with its own threshold, then the threshold is considered to be reached once one of the unit types has reached its threshold even if the other unit type has not been consumed.

When reporting volume quota, the DCCA always reports uplink and downlink separately using the CC-Input-Octets AVP and the CC-Output-Octets AVP, respectively.

On receipt of more quotas in the CCA the Gy discards any quota not yet consumed since sending the CCR. Thus the amount of quota now available for consumption is the new amount received less any quota that may have been consumed since last sending the CCR.

Conditions for Reauthorization of Quota

Quota is re-authorized/requested from the server in case of the following scenarios:

- Threshold is hit
- Quota is exhausted
- Validity time expiry
- Rating condition change:
 - Cellid change: Applicable only to GGSN and P-GW implementations.
 - LAC change: Applicable only to GGSN and P-GW implementations.
 - QoS change
 - RAT change
 - SGSN/Serving-Node change: Applicable only to GGSN and P-GW implementations.

Discarding or Allowing or Buffering Traffic to Flow

Whenever Gy is waiting for CCA from the server, there is a possibility of traffic for that particular traffic type to be encountered in the Gy. The behavior of what needs to be done to the packet is determined by the

configuration. Based on the configuration, the traffic is either allowed to pass or discarded or buffered while waiting for CCA from the server.

This behavior applies to all interrogation of client with server in the following cases:

- No quota present for that particular category
- Validity timer expiry for that category
- Quota exhausted for that category
- Forced Reauthorization from the server

In addition to allowing or discarding user traffic, there is an option available in case of quota exhausted or no quota circumstances to buffer the traffic. This typically happens when the server has been requested for more quota, but a valid quota response has not been received from the server, in this case the user traffic is buffered and on reception of valid quota response from the server the buffered traffic is allowed to pass through.

Procedures for Consumption of Time Quota

- QCT is zero: When QCT is deactivated, the consumption is on a wall-clock basis. The consumption is continuous even if there is no packet flow.
- QCT is active: When QCT is present in the CCA or locally configured for the session, then the consumption of quota is started only at the time of first packet arrival. The quota is consumed normally till last packet arrival plus QCT time and is passed till the next packet arrival.

If the QCT value is changed during intermediate interrogations, then the new QCT comes into effect from the time the CCA is received. For instance, if the QCT is deactivated in the CCA, then quota consumptions resume normally even without any packet flow. Or if the QCT is activated from deactivation, then the quota consumption resume only after receiving the first packet after CCA.

- QHT is zero: When QHT is deactivated, the user holds the quota indefinitely in case there is no further usage (for volume quota and with QCT for time quota). QHT is active between the CCA and the next CCR.
- QHT is non-zero: When QHT is present in CCA or locally configured for the session, then after a idle time of QHT, the quota is returned to the server by sending a CCR-Update and reporting usage of the quota. On receipt of CCR-U, the server does not grant quota. QHT timer is stopped on sending the CCR and is restarted only if QHT is present in the CCA.

QHT timer is reset every time a packet arrives.

Envelope Reporting

The server may determine the need for additional detailed reports identifying start time and end times of specific activity in addition to the standard quota management. The server controls this by sending a CCA with Envelope-Reporting AVP with the appropriate values. The DCCA client, on receiving the command, will monitor for traffic for a period of time controlled by the Quota-Consumption-Time AVP and report each period as a single envelope for each Quota-Consumption-Time expiry where there was traffic. The server may request envelope reports for just time or time and volume. Reporting the quota back to the server, is controlled by Envelope AVP with Envelope-Start-Time and Envelope-End-Time along with usage information.

Credit Control Request

Credit Control Request (CCR) is the message that is sent from the client to the server to request quota and authorization. CCR is sent before the establishment of MIP session, and at the termination of the MIP session. It can be sent during service delivery to request more quotas.

- Credit Control Request - Initial (CCR-I)
- Credit Control Request - Update (CCR-U)
- Credit Control Request - Terminate (CCR-T)
- Credit Control Answer (CCA)
- Credit Control Answer - Initial (CCA-I)
- Credit Control Answer - Update (CCA-U)

If the MSCC AVP is missing in CCA-U it is treated as invalid CCA and the session is terminated.

- Credit Control Answer - Terminate (CCA-T)

In releases prior to 16.0, CCR-T was immediately sent without waiting for CCA-U if the call was cleared and there was a pending CCA-U. In 16.0 and later releases, if call is cleared when there is a pending update, the gateway will wait for CCA-U to arrive or timeout to happen (whichever happens first).

In releases prior to 20, CCR-Ts were not reported over Gy interface when the calls were terminated due to audit failure during ICSR switchover. In 20 and later releases, DCCA allows generation of CCR-Ts in this scenario.

The following figure depicts the call flow for a simple call request in the GGSN/P-GW/IPSG Gy implementation.

Figure 34: Gy Call Flow for Simple Call Request for GGSN/P-GW/IPSG

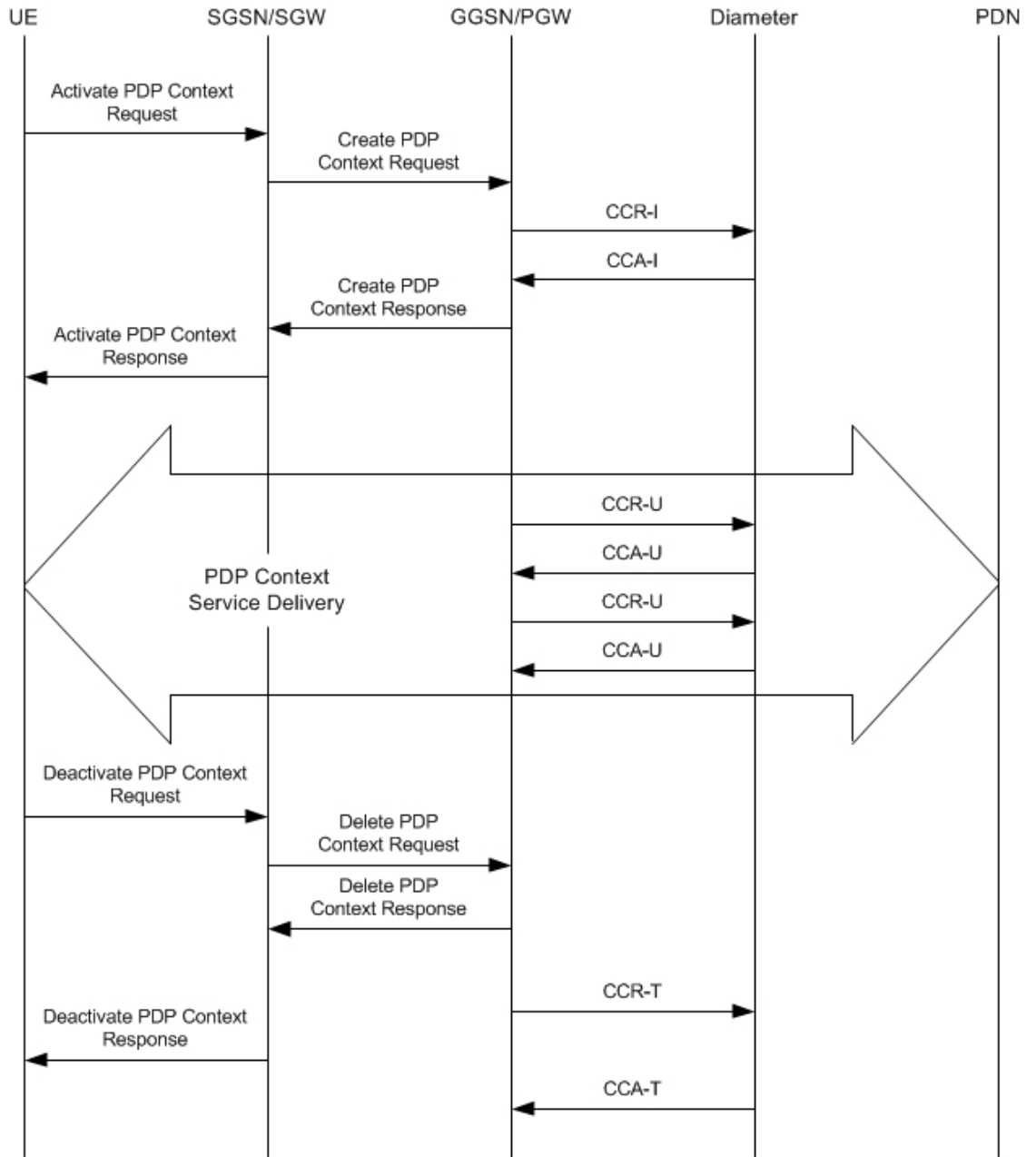

335187

The following figure depicts the call flow for a simple call request in the HA Gy implementation.

Figure 35: Gy Call Flow for Simple Call Request for HA

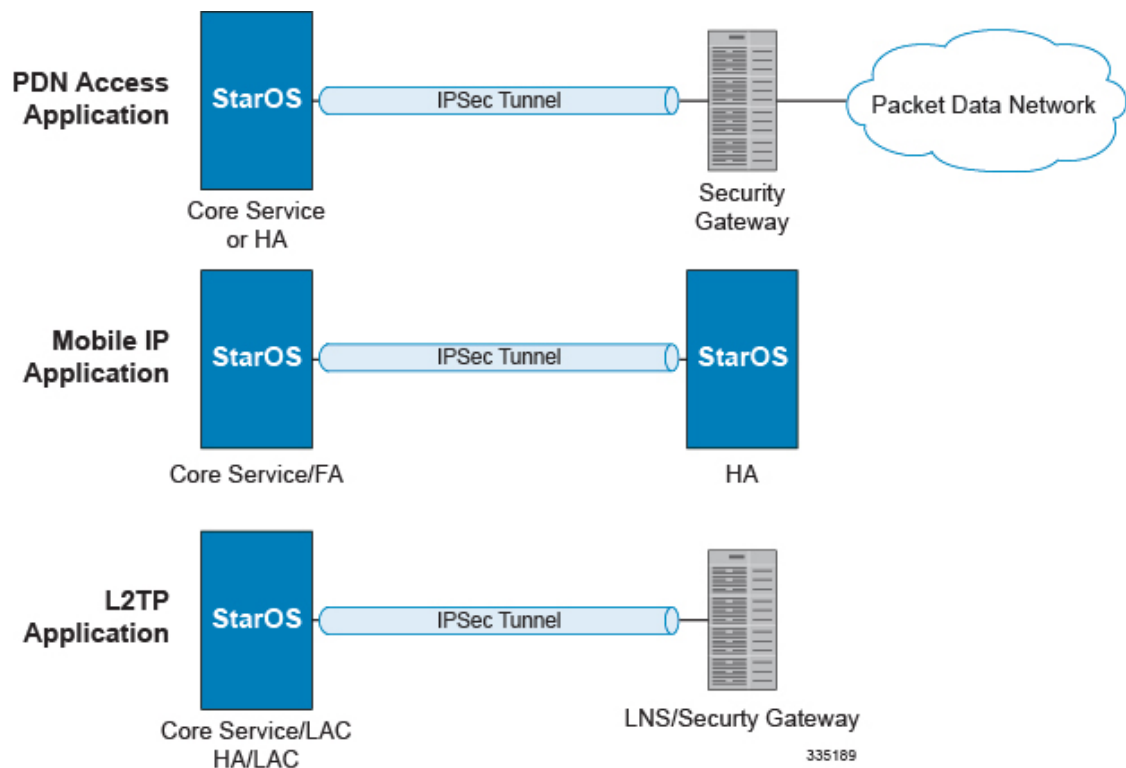

Tx Timer Expiry Behavior

A timer is started each time a CCR is sent out from the system, and the response has to arrive within Tx time. The timeout value is configurable in the Diameter Credit Control Configuration mode.

In case there is no response from the Diameter server for a particular CCR, within Tx time period, and if there is an alternate server configured, the CCR is sent to the alternate server after Tw expiry as described in "Tw Timer expiry behavior" section.

It also depends on the Credit-Control-Session-Failover AVP value for the earlier requests. If this AVP is present and is coded to FAILOVER_SUPPORTED then the credit-control message stream is moved to the secondary server, in case it is configured. If the AVP value is FAILOVER_NOT_SUPPORTED, then the call is dropped in case of failures, even if a secondary server is configured.

In releases prior to 16.0, once a CCR-U was sent out over Gy interface, ACR-I message was immediately triggered (or containers were cached) based on policy accounting configuration and did not wait for CCA-U. In 16.0 and later releases, containers are closed only after CCA-U is received successfully. That is, Rf trigger will be sent only after receiving CCA-U message.

Redirection

In the Final-Unit-Indication AVP, if the Final-Unit-Action is REDIRECT or Redirect-Server AVP is present at command level, redirection is performed.

The redirection takes place at the end of consumption of quota of the specified category. The Gy sends a CCR-Update without any RSU or Rating-Group AVP so that the server does not give any more quotas.

If the Final-Unit-Action AVP is RESTRICT_ACCESS, then according to the settings in Restriction-Filter-Rule AVP or Filter-Id AVP. Gy sends CCR-Update to the server with used quota.

Triggers

The Diameter server can provide with the triggers for which the client should reauthorize a particular category. The triggers can be configured locally as well but whatever trigger is present in the CCA from the server will have precedence.



Important In this release, Gy triggers are not supported for HA.

The trigger types that are supported are:

- SGSN/Serving-Node Change
- QoS Change - Any
- RAT Change
- LAC Change
- CellID Change

On any event as described in the Trigger type happens, the client reauthorizes quota with the server. The reporting reason is set as RATING_CONDITION_CHANGE.

Tariff Time Change

The tariff change mechanism applies to each category instance active at the time of the tariff change whenever the server indicated it should apply for this category.

The concept of dual coupon is supported. Here the server grants two quotas, which is accompanied by a Tariff-Time-Change, in this case the first granted service unit is used until the tariff change time, once the tariff change time is reached the usage is reported up to the point and any additional usage is not accumulated, and then the second granted service unit is used.

If the server expects a tariff change to occur within the validity time of the quota it is granting, then it includes the Tariff-Time-Change AVP in the CCA. The DCCA report usage, which straddles the change time by sending two instances of the Used-Service-Unit AVP, one with Tariff-Change-Usage set to UNIT_BEFORE_TARIFF_CHANGE, and one with Tariff-Change-Usage set to UNIT_AFTER_TARIFF_CHANGE, and this independently of the type of units used by application. Both Volume and Time quota are reported in this way.

The Tariff time change functionality can as well be done using Validity-Time AVP, where in the Validity-Time is set to Tariff Time change and the client will reauthorize and get quota at Validity-Time expiry. This will trigger a lot of reauthorize request to the server at a particular time and hence is not advised.

Tariff-Time-Usage AVP along with the Tariff-Time-Change AVP in the answer message to the client indicates that the quotas defined in Multiple-Services-Credit-Control are to be used before or after the Tariff Time change. Two separate quotas are allocated one for before Tariff-Time-Change and one for after Tariff-Time-Change. This gives the flexibility to the operators to allocate different quotas to the users for different periods of time. In this case, the DCCA should not send the Before-Usage and After-Usage counts in the update messages to the server. When Tariff-Time-Change AVP is present without Tariff-Time-Usage AVP in the answer message, then the quota is used as in single quota mechanism and the client has to send before usage and after usage quotas in the updates to the server.



Important In this release, Gy does not support UNIT_INDETERMINATE value.

In the StarOS 21.20.22 release, support for Tariff-Time-Change AVP is enhanced to maintain continuous traffic flow in the fast path and the user's traffic rate when the Tariff-Time-Change AVP is received from Gy for a Rating Group.

Final Unit Indication

The Final-Unit-Indication AVP can be present in the CCA from the server to indicate that the given quota is the final quota from the server and the corresponding action as specified in the AVP needs to be taken.

Final Unit Indication at Command Level

Gy currently does not support FUI AVP at command level. If this AVP is present at command level it is ignored. If the FUI AVP is present at command level and the Final-Unit-Action AVP set to TERMINATE, Gy sends a CCR-Terminate at the expiry of the quota, with all quotas in the USU AVP.



Important FUI AVP at command level is only supported for Terminate action.

Final Unit Indication at MSCC Level

If the Final-Unit-Indication AVP is present at MSCC level, and if the Final-Unit-Action AVP is set to TERMINATE, a CCR-Update is sent at the expiry of the allotted quota and report the usage of the category that is terminated.

For information on redirection cases refer to the [Redirection, on page 346](#).

Credit Control Failure Handling

CCFH AVP defines what needs to be done in case of failure of any type between the client and the server. The CCFH functionality can be defined in configuration but if the CCFH AVP is present in the CCA, it takes precedence. CCFH AVP gives flexibility to have different failure handling.

Gy supports the following Failure Handling options:

- TERMINATE
- CONTINUE
- RETRY AND TERMINATE

CCFH with Failover Supported

In case there is a secondary server is configured and if the CC-Session-Failover AVP is set to FAILOVER_SUPPORTED, the following behavior takes place:

- Terminate: On any Tx expiry for the CCR-I the message is discarded and the session is torn down. In case of CCR-Updates and Terminates the message is sent to the secondary server after response timeout and the session is proceeded with the secondary server. In case there is a failure with the secondary server too, the session is torn down.
- Continue: On any Tx expiry, the message is sent to the secondary server after response timeout and the session is proceeded with the secondary server. In case there is a failure with the secondary server too, the session is still established, but without quota management.

- **Retry and Terminate:** On any Tx expiry, the message is sent to the secondary server after the response timeout. In case there is a failure with secondary server too, the session is taken down.

CCFH with Failover Not Supported

In case there is a secondary server configured and if the CC-Session-Failover AVP is set to `FAILOVER_NOT_SUPPORTED`, the following behavior takes place as listed below. Same is the case if there is no secondary server configured on the system.

- **Terminate:** On any Tx expiry, the session is taken down.
- **Continue:** On any Tx expiry, the session is still established, but without quota management.
- **Retry and Terminate:** On any Tx expiry, the session is taken down.

Failover Support

The CC-Session-Failover AVP and the Credit-Control-Failure-Handling (CCFH) AVP may be returned by the CC server in the CCA-I, and are used by the DCCA to manage the failover procedure. If they are present in the CCA they override the default values that are locally configured in the system.

If the CC-Session-Failover is set to `FAILOVER_NOT_SUPPORTED`, a CC session will never be moved to an alternative Diameter Server.

If the value of CC-Session-Failover is set to `FAILOVER_SUPPORTED`, then the Gy attempts to move the CC session to the alternative server when it considers a request to have failed, i.e:

- On receipt of result code "DIAMETER_UNABLE_TO_DELIVER", "DIAMETER_TOO_BUSY", or "DIAMETER_LOOP_DETECTED".
- On expiry of the request timeout.
- On expiry of Tw without receipt of DWA, if the server is connected directly to the client.

The CCFH determines the behavior of the client in fault situations. If the Tx timer expires then based on the CCFH value the following actions are taken:

- **CONTINUE:** Allow the MIP session and user traffic for the relevant category or categories to continue, regardless of the interruption (delayed answer). Note that quota management of other categories is not affected.
- **TERMINATE:** Terminate the MIP session, which affects all categories.
- **RETRY_AND_TERMINATE:** Allow the MIP session and user traffic for the relevant category or categories to continue, regardless of the interruption (delayed answer). The client retries to send the CCR when it determines a failure-to-send condition and if this also fails, the MIP session is then terminated.

After the failover action has been attempted, and if there is still a failure to send or temporary error, depending on the CCFH action, the following action is taken:

- **CONTINUE:** Allow the MIP session to continue.
- **TERMINATE:** Terminate the MIP session.
- **RETRY_AND_TERMINATE:** Terminate the MIP session.

Recovery Mechanisms

DCCA supports a recovery mechanism that is used to recover sessions without much loss of data in case of Session Manager failures. There is a constant check pointing of Gy data at regular intervals and at important events like update, etc.



Important

The DCCA supports maximum of three bearers (including default) for the ICSR Checkpointing and Recovery. When more than three bearers are configured in the DCCA, checkpointing occurs from Active to Standby for all the bearers. However, during recovery, only the first three bearers are recovered and the rest remain in the memory consuming resources.

For more information on recovery mechanisms, please refer to the *System Administration Guide*.

Error Mechanisms

Following are supported Error Mechanisms.

Unsupported AVPs

All unsupported AVPs from the server with "M" bit set are ignored.

Invalid Answer from Server

If there is an invalid answer from the server, Gy action is dependent on the CCFH setting:

- In case of continue, the MIP session context is continued without further control from Gy.
- In case of terminate and retry-and-terminate, the MIP session is terminated and a CCR-T is sent to the diameter server.

Result Code Behavior

- **DIAMETER_RATING_FAILED**: On reception of this code, Gy discards all traffic for that category and does not request any more quota from the server. This is supported at the MSCC level and not at the command level.
- **DIAMETER_END_USER_SERVICE_DENIED**: On reception of this code, Gy temporarily blacklists the category and further traffic results in requesting new quota from the server. This is supported at the MSCC level and not at the command level.
- **DIAMETER_CREDIT_LIMIT_REACHED**: On reception of this code, Gy discards all traffic for that category and waits for a configured time, after which if there is traffic for the same category requests quota from the server. This is supported at the MSCC level and not at the command level.
- **DIAMETER_CREDIT_CONTROL_NOT_APPLICABLE**: On reception of this code, Gy allows the session to establish, but without quota management. This is supported only at the command level and not at the MSCC level.
- **DIAMETER_USER_UNKNOWN**: On reception of this code, DCCA does not allow the credit control session to get established, the session is terminated. This result code is supported only at the command level and not at the MSCC level.

For all other permanent/transient failures, Gy action is dependent on the CCFH setting.

Supported AVPs

The Gy functionality supports the following AVPs:

- Supported Diameter Credit Control AVPs specified in RFC 4006:
 - CC-Input-Octets (AVP Code: 412):
Gy supports this AVP only in USU.
 - CC-Output-Octets (AVP Code: 414):
Gy supports this AVP only in USU.
 - CC-Request-Number (AVP Code: 415)
 - CC-Request-Type (AVP Code: 416):
Gy currently does not support EVENT_REQUEST value.
 - CC-Service-Specific-Units (AVP Code: 417)
 - CC-Session-Failover (AVP Code: 418)
 - CC-Time (AVP Code: 420):
Gy does not support this AVP in RSU.
 - CC-Total-Octets (AVP Code: 421):
Gy does not support this AVP in RSU.
 - Credit-Control-Failure-Handling (AVP Code: 427)
 - Final-Unit-Action (AVP Code: 449):
Supported at Multiple-Services-Credit-Control grouped AVP level and not at command level.
 - Final-Unit-Indication (AVP Code: 430):
Fully supported at Multiple-Services-Credit-Control grouped AVP level and partially supported (TERMINATE) at command level.
 - Granted-Service-Unit (AVP Code: 431)
 - Multiple-Services-Credit-Control (AVP Code: 456)
 - Multiple-Services-Indicator (AVP Code: 455)
 - Rating-Group (AVP Code: 432)
 - Redirect-Address-Type (AVP Code: 433):
Gy currently supports only URL (2) value.
 - Redirect-Server (AVP Code: 434)
 - Redirect-Server-Address (AVP Code: 435)
 - Requested-Service-Unit (AVP Code: 437)
 - Result-Code (AVP Code: 268)
 - Service-Context-Id (AVP Code: 461)

- Service-Identifier (AVP Code: 439)
- Subscription-Id (AVP Code: 443)
- Subscription-Id-Data (AVP Code: 444)
- Subscription-Id-Type (AVP Code: 450)
- Tariff-Change-Usage (AVP Code: 452):
Gy does NOT support UNIT_INDETERMINATE (2) value.
- Tariff-Time-Change (AVP Code: 451)
- Used-Service-Unit (AVP Code: 446):
Gy sends only incremental counts for all the AVPs from the last CCA-U.
- User-Equipment-Info (AVP Code: 458)
- User-Equipment-Info-Type (AVP Code: 459):
Gy currently supports only IMEISV value.
Cisco GGSN and P-GW support IMEISV by default.
- User-Equipment-Info-Value (AVP Code: 460)
- Validity-Time (AVP Code: 448)
- Supported 3GPP specific AVPs specified in 3GPP TS 32.299:
 - 3GPP-Charging-Characteristics (AVP Code: 13)
 - 3GPP-Charging-Id (AVP Code: 2)
 - 3GPP-GGSN-MCC-MNC (AVP Code: 9)
 - 3GPP-GPRS-QoS-Negotiated-Profile (AVP Code: 5)
 - 3GPP-IMSI-MCC-MNC (AVP Code: 8)
 - 3GPP-NSAPI (AVP Code: 10)
 - 3GPP-PDP-Type (AVP Code: 3)
 - 3GPP-RAT-Type (AVP Code: 21)
 - 3GPP-Selection-Mode (AVP Code: 12)
 - 3GPP-Session-Stop-Indicator (AVP Code: 11)
 - 3GPP-SGSN-MCC-MNC (AVP Code: 18)
 - 3GPP-User-Location-Info (AVP Code: 22)
 - Base-Time-Interval (AVP Code: 1265)
 - Charging-Rule-Base-Name (AVP Code: 1004)
 - Envelope (AVP Code: 1266)
 - Envelope-End-Time (AVP Code: 1267)

- Envelope-Reporting (AVP Code: 1268)
 - Envelope-Start-Time (AVP Code: 1269)
 - GGSN-Address (AVP Code: 847)
 - Offline-Charging (AVP Code: 1278)
 - PDP-Address (AVP Code: 1227)
 - PDP-Context-Type (AVP Code: 1247)
This AVP is present only in CCR-I.
 - PS-Information (AVP Code: 874)
 - Quota-Consumption-Time (AVP Code: 881):
This optional AVP is present only in CCA.
 - Quota-Holding-Time (AVP Code: 871):
This optional AVP is present only in the CCA command. It is contained in the Multiple-Services-Credit-Control AVP. It applies equally to the granted time quota and to the granted volume quota.
 - Reporting-Reason (AVP Code: 872):
Gy currently does not support the POOL_EXHAUSTED (8) value. It is used in case of credit-pooling which is currently not supported.
 - Service-Information (AVP Code: 873):
Only PS-Information is supported.
 - SGSN-Address (AVP Code: 1228)
 - Time-Quota-Mechanism (AVP Code: 1270):
The Gy server may include this AVP in an Multiple-Services-Credit-Control AVP when granting time quota.
 - Time-Quota-Threshold (AVP Code: 868)
 - Time-Quota-Type (AVP Code: 1271)
 - Trigger (AVP Code: 1264)
 - Trigger-Type (AVP Code: 870)
 - Unit-Quota-Threshold (AVP Code: 1226)
 - Volume-Quota-Threshold (AVP Code: 869)
- Supported Diameter AVPs specified in 3GPP TS 32.299 V8.1.0:
 - Auth-Application-Id (AVP Code: 258)
 - Destination-Host (AVP Code: 293)
 - Destination-Realm (AVP Code: 283)
 - Disconnect-Cause (AVP Code: 273)

- Error-Message (AVP Code: 281)
- Event-Timestamp (AVP Code: 55)
- Failed-AVP (AVP Code: 279)
- Multiple-Services-Credit-Control (AVP Code: 456)
- Origin-Host (AVP Code: 264)
- Origin-Realm (AVP Code: 296)
- Origin-State-Id (AVP Code: 278)
- Redirect-Host (AVP Code: 292)
- Redirect-Host-Usage (AVP Code: 261)
- Redirect-Max-Cache-Time (AVP Code: 262)
- Rating-Group (AVP Code: 432)
- Result-Code (AVP Code: 268)
- Route-Record (AVP Code: 282)
- Session-Id (AVP Code: 263)
- Service-Context-Id (AVP Code: 461)
- Service-Identifier (AVP Code: 439)
- Supported-Vendor-Id (AVP Code: 265)
- Termination-Cause (AVP Code: 295)
- Used-Service-Unit (AVP Code: 446)
- User-Name (AVP Code: 1)

Unsupported AVPs

This section lists the AVPs that are NOT supported.

- NOT Supported Credit Control AVPs specified in RFC 4006:
 - CC-Correlation-Id
 - CC-Money
 - CC-Sub-Session-Id
 - CC-Unit-Type (AVP Code: 454)
 - Check-Balance-Result
 - Cost-Information (AVP Code: 423)
 - Cost-Unit (AVP Code: 445)
 - Credit-Control

- Currency-Code (AVP Code: 425)
 - Direct-Debiting-Failure-Handling (AVP Code: 428)
 - Exponent (AVP Code: 429)
 - G-S-U-Pool-Identifier (AVP Code: 453)
 - G-S-U-Pool-Reference (AVP Code: 457)
 - Requested-Action (AVP Code: 436)
 - Service-Parameter-Info (AVP Code: 440)
 - Service-Parameter-Type (AVP Code: 441)
 - Service-Parameter-Value (AVP Code: 442)
 - Unit-Value (AVP Code: 424)
 - Value-Digits (AVP Code: 447)
- NOT supported Diameter AVPs specified in 3GPP TS 32.299 V8.1.0:
 - Acct-Application-Id (AVP Code: 259)
 - Error-Reporting-Host (AVP Code: 294)
 - Experimental-Result (AVP Code: 297)
 - Experimental-Result-Code (AVP Code: 298)
 - Proxy-Host
 - Proxy-Info
 - Proxy-State
- NOT supported 3GPP-specific AVPs specified in 3GPP TS 32.299 V8.1.0:
 - 3GPP-CAMEL-Charging-Info (AVP Code: 24)
 - 3GPP-MS-TimeZone (AVP Code: 23)
 - 3GPP-PDSN-MCC-MNC
 - Authorised-QoS
 - Access-Network-Information
 - Adaptations
 - Additional-Content-Information
 - Additional-Type-Information
 - Address-Data
 - Address-Domain
 - Addressee-Type
 - Address-Type
 - AF-Correlation-Information
 - Alternate-Charged-Party-Address
 - Application-provided-Called-Party-Address
 - Application-Server

- Application-Server-Information
- Applic-ID
- Associated-URI
- Aux-Applic-Info
- Bearer-Service
- Called-Asserted-Identity
- Called-Party-Address
- Calling-Party-Address
- Cause-Code
- Charged-Party
- Class-Identifier
- Content-Class
- Content-Disposition
- Content-Length
- Content-Size
- Content-Type
- Data-Coding-Scheme
- Deferred-Location-Event-Type
- Delivery-Report-Requested
- Destination-Interface
- Domain-Name
- DRM-Content
- Early-Media-Description
- Event
- Event-Type
- Expires
- File-Repair-Supported
- IM-Information
- IMS-Charging-Identifier (ICID)
- IMS-Communication-Service-Identifier
- IMS-Information
- Incoming-Trunk-Group-ID
- Interface-Id
- Interface-Port
- Interface-Text
- Interface-Type
- Inter-Operator-Identifier
- LCS-APN
- LCS-Client-Dialed-By-MS
- LCS-Client-External-ID
- LCS-Client-ID
- LCS-Client-Name
- LCS-Client-Type
- LCS-Data-Coding-Scheme
- LCS-Format-Indicator
- LCS-Information

- LCS-Name-String
- LCS-Requestor-ID
- LCS-Requestor-ID-String
- Location-Estimate
- Location-Estimate-Type
- Location-Type
- Low-Balance-Indication
- MBMS-Information
- MBMS-User-Service-Type
- Media-Initiator-Flag
- Media-Initiator-Party
- Message-Body
- Message-Class
- Message-ID
- Message-Size
- Message-Type
- MMBBox-Storage-Requested
- MM-Content-Type
- MMS-Information
- Node-Functionality
- Number-Of-Participants
- Number-Of-Received-Talk-Bursts
- Number-Of-Talk-Bursts
- Originating-IOI
- Originator
- Originator-Address
- Originator-Interface
- Originator-SCCP-Address
- Outgoing-Trunk-Group-ID
- Participant-Access-Priority
- Participants-Group
- Participants-Involved
- PDG-Address
- PDG-Charging-Id
- PoC-Change-Condition
- PoC-Change-Time
- PoC-Controlling-Address
- PoC-Group-Name
- PoC-Information
- PoC-Server-Role
- PoC-Session-Id
- PoC-Session-Initialtion-Type
- PoC-Session-Type
- PoC-User-Role
- PoC-User-Role-IDs
- PoC-User-Role-info-Units

- Positioning-Data
- Priority
- PS-Append-Free-Format-Data (AVP Code: 867):
The PCEF/GW ignores this AVP if no PS free format data is stored for the online charging session.
- PS-Free-Format-Data (AVP Code: 866)
- PS-Furnish-Charging-Information (AVP Code: 865)
- RAI (AVP Code: 909)
- Read-Reply-Report-Requested
- Received-Talk-Burst-Time
- Received-Talk-Burst-Volume
- Recipient-Address
- Recipient-SCCP-Address
- Refund-Information
- Remaining-Balance
- Reply-Applic-ID
- Reply-Path-Requested
- Requested-Party-Address
- Role-of-node
- SDP-Answer-Timestamp
- SDP-Media-Component
- SDP-Media-Description
- SDP-Media-Name
- SDP-Offer-Timestamp
- SDP-Session-Description
- SDP-TimeStamp
- Served-Party-IP-Address
- Service-Generic-Information
- Service-ID
- Service-Specific-Data
- Service-Specific-Info
- Service-Specific-Type
- SIP-Method
- SIP-Request-Timestamp
- SIP-Response-Timestamp
- SM-Discharge-Time
- SM-Message-Type
- SM-Protocol-Id
- SMSC-Address
- SMS-Information
- SMS-Node
- SM-Status
- SM-User-Data-Header
- Submission-Time
- Talk-Burst-Exchange

- Talk-Burst-Time
- Talk-Burst-Volume
- Terminating-IOI
- Time-Stamps
- Token-Text
- Trunk-Group-ID
- Type-Number
- User-Participating-Type
- User-Session-ID
- WAG-Address
- WAG-PLMN-Id
- WLAN-Information
- WLAN-Radio-Container
- WLAN-Session-Id
- WLAN-Technology
- WLAN-UE-Local-IPAddress

PLMN and Time Zone Reporting

For some implementations of online charging, the OCS requires the PCEF to reporting location-specific subscriber information. For certain subscriber types, subscriber information such as PLMN, Time Zone, and ULI can be sent over the Gy interface as the subscriber changes location, time zone, and serving networks to provide accurate online charging services. Such information can be reported independently from time and volume-based reporting.

PLMN and Time Zone Reporting feature is enabled to support location event reporting based on triggers from Gx, when the following conditions are met:

- Session-based Gy is not initiated due to the absence of charging-actions in rulebase with Credit-Control enabled or due to delayed Gy session initiation.
- PLMN and Time Zone Reporting feature is either enabled in the credit control group or through the use of triggers received from Gx.

If session-based Gy initiation fails or the session goes offline due to configuration or network issues, event-based Gy session will not be initiated.



Important

Note that the failure-handling will not be supported for event-based Gy.

Though, in event-based Gy, multiple events can be reported independently and simultaneously this is presently not supported. If an event occurs when the CCA-Event (CCA-E) of the previously reported event is awaited, then the new event is queued and reported only when a CCA-E is received or the message is timed out.

To enable the PLMN and Time Zone Reporting feature, the PCRF shall send the Trigger AVP (Trigger Type 1, Trigger Type 2) at the command level in a CCA.

The Event-based Gy session will be terminated in the following scenarios:

- On termination of the bearer/subscriber (subscriber level Gy).
- Initiation of session-based Gy session (delayed session initiation).

- Once the CCR-E transaction is complete and there are no further events to report.

For information on how to configure this feature, refer to the *Gy Interface Support* chapter in the administration guide for the product that uses the Gy interface functionality.

Interworking between Session-based Gy and Event-based Gy

If both session-based Gy and event-based Gy mode are activated, then session-based Gy will take precedence i.e. all the events will be reported through CCR-U if the corresponding triggers are enabled. Event-based Gy mode will be active only when session-based Gy has been disabled and has never been activated previously for this session during its lifetime.

OCS Unreachable Failure Handling Feature

The OCS Unreachable Failure Handling feature is required to handle when OCS goes down or unavailable. This feature is otherwise noted as Assume Positive for Gy.

The OCS is considered unavailable/unreachable in the following scenarios:

- PCEF transmits a CCR-U or CCR-I message but no response is received before the specified timeout
- Diameter Watchdog request times out to the current RDR, causing the TCP connection state to be marked down
- Diameter command-level error codes received in a CCA
- If the PCEF is unable to successfully verify transmission of a CCR-T, the PCEF will not assign interim quota, because the user has disconnected.

In 15.0 and later releases, the error result codes can be configured using the CLI command **servers-unreachable behavior-triggers initial-request { result-code { any-error | result-code [to end-result-code] }** } to trigger the server unreachable mode. The same is applicable for the update request also. For more information on the CLI command, see the *Credit Control Configuration Mode Commands* chapter of the *Command Line Interface Reference*. However, if the CLI command **no servers-unreachable behavior-triggers { initial-request | update-request } result-code { any-error | result-code [to end-result-code] }** is configured, then the default set of hard-coded error codes are applicable.

The default set is:

- UNABLE_TO_DELIVER 3002
- UNABLE_TOO_BUSY 3004
- LOOP_DETECTED 3005
- ELECTION_LOST 4003
- Permanent failures 5001-5999 except 5002, 5003 and 5031.

In 12.2 and later releases, existing failure handling mechanism is enhanced such that the subscriber can be allowed to browse for a pre-configured amount of interim-volume and/or interim-time if OCS becomes unreachable due to transport connection failure or gives an impression that OCS is unreachable owing to slow response for Diameter request messages.

The purpose of this feature is to support Gy based data sessions in the event of an OCS outage. Diameter client allows the user's data session to continue for some fixed quota and then retries the OCS server to restore normal functionality. This feature adds more granularity to the existing failure handling mechanism.

With the implementation of this feature, Gy reporting during outages is supported. A temporary time and/or volume quota is assigned to the user in the event of an OCS outage which will be used during the outage period.

When the OCS returns to service, the GW reports all used quota back to OCS and continues with normal Gy reporting.

For each DCCA-service, CLI control is available for the following options:

- Interim quota volume (in bytes) and quota time (seconds). Both values will apply simultaneously, if configured together and if either quota time or quota volume is exhausted, the Diameter client retries the OCS.
- Option to limit the number of times a session can be assigned a temporary quota. If the user exceeds this amount, the session will be terminated/converted to postpaid.

The quota value is part of the dcca-service configuration, and will apply to all subscribers using that dcca-service. The temporary quota will be specified in volume (bytes) and/or time (seconds) to allow enforcement of both quota tracking mechanisms individually or simultaneously.

When a user consumes the interim total quota or time configured for use during failure handling scenarios, the GW retries the OCS server to determine if functionality has been restored. In the event that services have been restored, quota assignment and tracking will proceed as per standard usage reporting procedures. Data used during the outage will be reported to the OCS.

In the event that the OCS services have not been restored, the GW re-allocates the configured amount of quota and/or time to the user. The GW reports all accumulated used data back to OCS when OCS is back online. If multiple retries and interim allocations occur, the GW reports quota used during all allocation intervals. This cycle will continue until OCS services have been successfully restored, or the maximum number of quota assignments has been exhausted.

Support for OCS unreachable CLI commands is added under Diameter Credit Control Configuration mode.

For the P-GW/XGW/GGSN, this behavior will apply to all APNs and subscribers that have online charging enabled by the PCRF. In the HA, this behavior will apply to all users that have online charging enabled by the AAA. Settings will be applied to the dcca-service.

In Release 15.0, the following enhancements are implemented as part of the Assume Positive Gy feature:

- Configurable per error code treatment to enter assume positive mode
- Graceful session restart upon receipt of a 5002 error



Important

Note that the Graceful session restart feature is customer specific. For more information contact your Cisco account representative.

Configurable per Error Code Treatment

This feature allows the customers to configure error result codes using the CLI command "**servers-unreachable behavior-triggers**" that will trigger entering assume positive mode on the fly for CCR-Initial and CCR-Update messages. CCR-Terminate message is currently not supported.

Any error result codes from the range 3xxx to 5xxx can be specified using the CLI commands. This feature has been implemented to provide more flexibility and granularity in the way assume positive mode is triggered for error result codes.

Graceful Session Restart

Graceful session restart upon receipt of a 5002 error code is supported for server retried CCR-U messages during assume positive state. Also, any unreported usage from the time, server retried CCR-U sent till CCA-I is received, will be reported immediately by triggering CCR-U with usages for the same.



Important Note that the Graceful session restart feature is customer specific. For more information contact your Cisco account representative.

Any pending updates are aborted once CCA-U with 5002 is received from the server. Also CCR-U is triggered immediately following session restart only if there are any unreported usages pending.



Important When the server responds with 5002 error result code, it does not include any granted service units for the requested rating groups.

For more information on the commands introduced in support of this feature, see the *Credit Control Configuration Mode Command* chapter in the *Command Line Interface Reference*.

Enhancement to OCS Failure Reporting for Gy

Feature Description

When Cisco-Event-Trigger-Type AVP is installed by PCRF in CCA-I, CCA-U or in RAR messages with value CREDIT_CONTROL_FAILURE (5), then the Cisco-Event grouped AVP is sent by the P-GW to PCRF in CCR-U message with the exact value of OCS failure code. This trigger is sent only when Gy failure occurs and based on the configuration (Credit-Control-Failure-Handling), the 'Continue' action is taken and Gy session moves to Offline state.

In releases prior to the implementation of this enhancement, if a failure code was received from OCS in the range of 3000-3999, then Cisco-CC-Failure-Type was sent with the value 3XXX. Similarly, for error codes in the range of 4000-4999 or 5000-5999, Cisco-CC-Failure-Type was reported as 4XXX or 5XXX respectively. With this enhancement, the exact failure code is reported to the PCRF instead of the range. For example, when the Cisco-Event-Trigger-Type is CREDIT_CONTROL_FAILURE (5) and OCS failure code is 3002 in CCA-U, then in CCR-U towards PCRF Cisco-CC-Failure-Type (as part of grouped AVP Cisco-Event) is sent with a value of 3002.

Backpressure Handling

Diameter base (Diabase) maintains an outbound stream. When an application wants to write a message into a socket, the message handle of those messages are stored in the outbound stream. Only on receiving the response to the corresponding request, the stored message handle is removed from the outbound stream. In order to rate-limit the message transactions based on the responses received from the server, ASR 5500 maintains a limit on the number of messages stored in the outbound stream. This is done using "max-outstanding <>" CLI (default value is 256). If the number of messages created by the application exceeds the max-outstanding limit, diabase sends a 'Backpressure' indication to the application to wait till it receives a decongestion indication from diabase to try again.

On receiving a response from the server, the corresponding request message handle will be removed from the outbound stream, creating a slot for another message to be written by the application. In order to intimate this

slot availability, decongestion notification is sent to the registered application. The application in turn loops through all sessions and processes the pending trigger to be sent.

When the application loops through the sessions in the system, it traverse the sessions in a sorted order and checks each session whether it has to send a pending CCR-Initial or CCR-Terminate or CCR-Update. When the first session gets the slot to fill the outbound stream, it writes the message into the stream. Now the slot gets back into filled state, reaching the max-outstanding limit again. So the rest of the sessions will still continue to be in backpressured state.

Backpressured request like Credit-Control-Initial and Credit-Control-Terminate are given higher priority over Credit-Control-Update as they are concerned with the creation or termination of a session. So on top of the decongestion notification, DCCA has some internal timers which periodically try to send the message out. So in case of heavy backpressure condition, the probability of CCR-I or CCR-T being sent out is more than CCR-U.

Gy Backpressure Enhancement

This feature facilitates maintaining a list of DCCA sessions that hit backpressure while creating a message i.e., backpressured list, eliminating the current polling procedure. This will maintain a single queue for all types of messages (CCR-I, CCR-U, CCR-T, CCR-E) that are backpressured. The messages will be sent in FIFO order from the queue.

After processing a session from the backpressure queue DCCA will check for the congestion status of the peer and continue only if the peer has empty slots in the outstanding message queue to accommodate further CCRs.

Releases prior to 16.0, the gateway has a max-outstanding configuration to manage a number of messages that are waiting for response from OCS. When the max-outstanding is configured to a low value, then the frequency to be in congested state is very high.

CPU utilization is very high if the max-outstanding count is low and network is congested.

In 16.0 and later releases, all DCCA sessions associated with the CCR messages that are triggered BACKPRESSURE (when max-outstanding has been reached) will be queued in backpressure list which is maintained per ACS manager instance (credit-control) level.

This list will not have any specific configurable limits on the number of sessions that will be queued in it. This is because there is an inherent limit that is already present which is dependent on the number of subscriber/DCCA sessions.

With this new separate backpressured list, CPU utilization will come down under high backpressure case.

Gy Support for GTP based S2a/S2b

For WiFi integration in P-GW, Gy support is provided for GTP based S2a/S2b in Release 18.0. This implementation is in compliance with standard Rel-11 non-3GPP access spec of 32.399: S5-120748 S5-131017 S5-143090.

As part of this enhancement, the following AVP changes are introduced:

- Added TWAN as a new enum value for Serving-Node-Type AVP
- Added a new Diameter AVP "TWAN-User-Location-Info". This is a grouped AVP and it contains the UE location in a Trusted WLAN Access Network (TWAN): BSSID and SSID of the access point.

The TWAN AVPs will be effective only for 3GPP release 11 and it is added only to the standard Gy dictionary. That is, the TWAN AVP will be included in CCR-I/CCR-U/CCR-T messages only when the CLI command "**diameter update-dictionary-avps 3gpp-rel11**" is configured.

Generating OOC/ROC with Changing Association between Rule and RG

The existing Gy implementation prevents duplicate Out-of-Credit (OOC) / Reallocation of Credit (ROC) report for the same rule to the PCRF. Subscriber throttling with the same rule with different Rating-Group across OOC event does not work. To overcome this, the following implementation is considered:

When a Rating-Group runs out of credit, OOC is sent to all rules that are currently associated with that Rating-Group. This is done irrespective of whether that rule was already OOC'd or not. Similarly, when a Rating-Group gets quota after being in OOC state, a ROC is sent to all rules that are currently associated with that Rating-Group. This is done irrespective of whether that rule was already ROC'd or not.

In releases prior to 18, MSCC's state was previously being maintained at MSCC and rule-level to suppress OOC/ROC events. So if MSCC triggered an OOC/ROC the same was suppressed by the status maintained at the rule-level if the previous event on the rule was the same.

In 18 and later releases, the rule level status bits are no longer used to avoid similar back-to-back OOC/ROC events. Now, the triggering of OOC/ROC events will solely be dependent on the MSCC state and triggers.

Customers might see an increase in OOC/ROC events on Gx if they change the association of the rule and RG or if they use the Override feature.

Static Rulebase for CCR

An APN/subscriber can have a single rulebase applied to it, but allowing a static rulebase configuration to always pass a different or same rulebase to the OCS through CCR messages.

A new CLI command "**charging-rulebase-name rulebase_name**" has been introduced under Credit Control (CC) group to override/change the rulebase name present in APN/subscriber template, in the CCR AVP "Charging-Rule-Base-Name". The rulebase value configured in CC group will be sent to OCS via CCR. If this CLI command is not configured, then the rulebase obtained from APN/subscriber template will be sent to OCS.

The configured value of rulebase under CC group is sent in all CCR (I/U/T) messages. This implies that any change in rulebase value in CC group during mid-session gets reflected in the next CCR message.

This feature, when activated with the CLI command, reduces the complication involved in configuration of services like adding and removing services per enterprise on the OCS system.

CC based Selective Gy Session Control

This section describes the overview and implementation of the Selective Gy Session Control feature based on Charging Characteristics (CC) profile of the subscriber.

This section discusses the following topics for this feature:

- [Feature Description, on page 365](#)
- [Configuring CC based Selective Gy Session Control, on page 365](#)
- [Monitoring and Troubleshooting the Selective Gy Session Control Feature, on page 366](#)

Feature Description

The functionality that allows users to configure certain Charging Characteristics (CC) values as prepaid/postpaid is available for GGSN service. In Release 17, this functionality is extended to P-GW service.

To enable/disable Gy session based on the CC value received, the APN configuration is extended so that additional credit-control-groups/prepaid prohibited value can be configured for each of the CC values.

The **cc profile *cc-profile-index* prepaid prohibited** CLI command is used to configure the CC values to disable Credit-Control based charging. The P-GW/GGSN/SAEGW service subscriber sessions using this APN, can use this configuration to stop the triggering of Gy messages towards the OCS.

The UE provides the charging characteristics value and the active subscriber is connected through an APN. The CC index mapping is done for a corresponding CC group/prepaid prohibited value configured under the APN. Depending on the match, the Gy session is enabled or disabled towards the OCS.

The Session controller stores/updates the APN configuration in the AAA manager. During the session setup, the session manager fills the CC value received in session authenticate request, and sends it to AAA manager. The AAA manager matches this against the locally stored APN configuration, and selects the desired credit-control-group/prepaid-prohibited configuration for the session. Then the session manager passes this credit-control-group/prepaid-prohibited information received from the AAA manager to ACS manager.

When the local authentication (session setup request) is done, the credit-control group with the matching charging characteristic is selected and used. If there is no matching charging characteristic configuration found for the credit-control group selection, then the default credit-control group for the APN is selected.

When a particular CC is configured as postpaid, any session with this CC does not trigger Gy connection. Any change in the CC during the lifetime of session is ignored.

The CC based Gy Session Controlling feature is applicable only for the CC value received via GTP-Auth-Request, and during the session establishment. The CC value updated via AAA/PCRF after the session setup will not cause any change in already selected credit-control group. Once the credit-control group is selected after session setup, this feature is not applicable.

Relationships to Other Features

This feature can also be used when the CC profile configuration is enabled through the GGSN service. When the CC profile is configured under APN service and GGSN service, the prepaid prohibited configuration for the matching CC profile is applied irrespective of the services.

Limitations

The following are the limitations of this feature:

- One charging characteristic value can be mapped to only one credit-control-group/prepaid-prohibited configuration within one APN.
- The charging-characteristic based OCS selection is possible only during the session-setup. Once the credit-control-group is selected (after session setup), this feature is not applicable.

Configuring CC based Selective Gy Session Control

The following sections provide the configuration commands to configure the Gy Session Control feature based on the CC profile of the subscriber.

Configuring CC Value

The following commands are used to configure Charging Characteristic values as postpaid/prepaid to disable/enable Gy session towards the OCS.

```
configure
  context context_name
    apn apn_name
      cc-profile { cc_profile_index | any } { prepaid-prohibited |
credit-control-group cc_group_name }
    end
```

Notes:

- *cc_profile_index*: Specifies the CC profile index. *cc_profile_index* must be an integer from 0 through 15.
- **any**: This keyword is applicable for any non-overridden cc-profile index. This keyword has the least priority over specific configuration for a CC profile value. So, configuring **any** keyword will not override other specific configurations under APN.
- **prepaid-prohibited**: Disables prepaid Gy session for the configured profile index.
- *cc_group_name*: Specifies name of the credit control group as an alphanumeric string of 1 through 63 characters.
- **no cc-profile** *cc_profile_index*: This command falls back to "any" cc-profile behavior irrespective of the CC profile index value configured.

Verifying the Selective Gy Session Control Configuration

Use the following command in Exec mode to display/verify the configuration of Selective Gy Session Control feature.

```
show configuration
```

Monitoring and Troubleshooting the Selective Gy Session Control Feature

This section provides information regarding show commands and/or their outputs in support of the Selective Gy Session Control feature.

show active-charging sessions

The "Credit-Control" field that appears as part of the **show active-charging sessions [callid | imsi | msisdn]** command output enables the user to determine the credit control state as "On" for online charging enabled session or "Off" for prepaid prohibited session and monitor the subscriber session.

Credit-Control Group in Rulebase Configuration

This section describes the overview and implementation of the Credit-Control (CC) Group Selection based on the rulebase of the subscriber.

This section discusses the following topics for this feature:

- [Feature Description, on page 367](#)
- [Configuring Credit-Control Group in Rulebase, on page 368](#)
- [Monitoring and Troubleshooting the CC-Group Selection in Rulebase, on page 368](#)

Feature Description

This feature is introduced to customize the behavior for different types of subscribers in the Assume Positive scenario. This customization is made by enabling the users to specify a desired Credit-Control (CC) group based on the rulebase dynamically selected by PCRF.

Typically, the behavior for Assume Positive is configured within the CC group. In releases prior to 20, there were options to choose the CC group through APN/subscriber-profiles, IMSA, or AAA configurations. In this release, the CC group selection functionality is extended to rulebase configuration.

This feature is explicitly required in scenarios where IMSA was not used, AAA server could not send CC group during authentication, and only a single APN/subscriber-profile was used for all the subscribers. In such situations, this feature targets to provide a premium CC group within rulebase to enable premium treatment to subscribers based on their types.

This feature introduces a new configurable option inside the rulebase configuration, so that the users can specify the desired CC group whenever the rulebase is selected during the subscriber session setup. This configured CC group overrides or has a higher priority than the CC group configured within the subscriber profile/APN. If the AAA or PCRF server sends the CC-Group AVP, the CC group value defined through the AVP overrides the rulebase configured CC group.

When this feature is enabled, the configuration allows specifying an association between the rulebase name and the CC group so that when a premium subscriber connects, a premium rulebase and a premium CC group are selected.



Important

Mid-session configuration change will not impact the existing subscribers in the system. This configuration change will be effected only to the new sessions.

Implementing this new configuration option enables different types of Assume-Positive behavior for subscribers based on the available quota. This results in achieving preferential treatment for premium customers.

The precedence order for selection of the CC group is defined as:

- PCRF provided CC group
- AAA provided CC group
- Rulebase configured CC group
- Subscriber Profile/APN selected CC group
- Default Credit-Control group



Important

This feature should not be used when there is an option for AAA server to send the CC group during authentication process. If during the authentication, AAA server sends a CC group, and the rulebase selected has a CC group defined within, then the rulebase defined CC group is selected for the session.

Limitations

There are no limitations or restrictions with this feature. However, it is important to keep in mind the precedence order for CC group selection.

Configuring Credit-Control Group in Rulebase

The following sections provide the configuration commands to configure the Credit-Control Group based on the rulebase of the subscriber.

Defining Credit-Control Group

The following commands are used to configure a desired Credit-Control group name when using the rulebase selected by PCRF.

```
configure
require active-charging
active-charging service service_name
    rulebase rulebase_name
        credit-control-group cc_group_name
    end
```

- *cc_group_name*: Specifies name of the credit control group as an alphanumeric string of 1 through 63 characters.
- **no credit-control-group**: Removes the previously configured CC group from the rulebase configuration. This is the default setting.
- This CLI configuration is applicable only during the session setup. Mid-session change in the CC group is not allowed.
- This is an optional CLI configuration, and used only when customized Assume Positive behavior is required for subscribers.
- If this CLI command is configured, the selection of the CC group will be based on the precedence order. That is, the rulebase defined CC group has higher precedence over the CC group value specified in the Subscriber/APN profile.
- If the CC group configuration is not present in the rulebase, the default subscriber/APN profile configuration is applied.

Verifying the Credit-Control Group Configuration

Use the following command in Exec mode to display/verify the configuration of CC group in rulebase.

```
show configuration verbose
```

Monitoring and Troubleshooting the CC-Group Selection in Rulebase

This section provides information regarding show commands and/or their outputs in support of this feature.

show active-charging sessions full

The output of this show CLI command displays the selected credit-control-group for the session. The output details are useful in verifying and troubleshooting the issues with this feature.

show configuration errors

This show CLI will list an error if the credit-control group that is configured inside the rulebase is not defined.

show configuration verbose

This command will show the "credit-control-group" option specified for the rulebase. For troubleshooting purpose, capture the output of **show configuration verbose** and **show subscribers full** along with the **monitor-protocol** output containing "Radius Access-Accept".

Combined CCR-U Triggering for QoS Change Scenarios

In release 20, the number of CCR-Us sent to the OCS is controlled for QoS change scenarios in P-GW call. This new behavior is introduced in the system to easily handle the issues with Transactions Per Second (TPS) on OCS.

In releases prior to 20, for a change in the default EPS bearer QoS and APN AMBR received from PCRF for LTE or S2b WiFi calls, P-GW used to send two separate CCR-Us to OCS through Gy interface, one each for QoS change and AMBR change. In 20 and later releases, when default EPS bearer QoS and APN AMBR values are changed, P-GW sends update request to access side to change default bearer and APN AMBR in a single message. P-GW will apply APN AMBR and default bearer QoS accordingly and will send only one CCR-U on Gy for this change condition.



Important

This behavior change is applicable only to P-GW calls. This change has no impact to the Rf/CDR records, and GGSN/P-GW eHRPD calls.

Also, note that this behavior is not applicable for split TFT case (QoS + APN AMBR + TFT) wherein multiple Update Bearer Requests are sent towards the access side.

Re-activating Offline Gy Session after Failure

This section describes the feature to re-enable Offline Gy session on detecting failure at Diameter Credit Control Application.

This section includes the following topics:

Feature Description

With this feature, a mechanism to re-enable the Offline Gy session back to Online charging, based on indication from PCRF is introduced in this release. Upon receiving the Online AVP from PCRF, the gateway will establish the Gy session.

In previous releases, there was no provision to activate Gy once the session was marked as Offline. On detecting failure at Diameter Credit Control Application, the configured Credit Control Failure Handling (CCFH) action would be taken. Once the Gy session has taken the CCFH Continue action, the subscriber session could not be retried/re-enabled.

The Online AVP in the Charging-Rule-Definition is considered as the trigger/indication from PCRF to enable the Offline Gy session, after the CCFH Continue action been taken. The Online AVP at the command level from PCRF will not be considered as a trigger to enable the Offline Gy session. As per 3GPP 29.212 (release 12.12.0), the Online AVP (1009) is an optional AVP inside the Charging-Rule-Definition grouped AVP (1003).

Limitations and Restrictions

This section lists the limitations and configuration restrictions with this feature:

- This feature is limited only to Volume Quota mechanism. Special handling is not done for Quota-Validity-Time (QVT) and Quota-Hold-Time (QHT) timers. When the Gy session goes offline and comes back again, these timers are not started. The timers will be started only when the next CCA-U provides the information from OCS.
- When the Gy session is marked Online, CDR closure is not required and this is handled by the billing system.
- This feature is not extended to the event-based credit-control sessions.
- When the CCFH action is taken due to MSCC level failure, the existing behavior is retained and the following behavior is observed:
 - CCFH Continue – Continue the category (MSCC) without charging at Gy and this is applicable to the MSCC (not to the entire session). The MSCC state in the output of the **show active-charging sessions full** command will display "No Charge".
 - CCFH Terminate/Retry-and-Terminate – The bearer gets terminated.
- When the Result-Code 4011 (DIAMETER_CREDIT_CONTROL_NOT_APPLICABLE) is received at MSCC level, the category is marked Free-of-Charge and no further accounting for this category is done. When this result code is received at command level, the Gy session is made Offline. The Offline Gy session can be made Online again using the Online AVP from PCRF and the accounting will resume normally (CCR-U will be seen at OCS for this session).
- When CCFH Continue is configured and CCR-I failure occurs, the following behavior is observed:
 - Diabase Error – When diabase error (TCP connection down) occurs, the Gy session is marked Offline and the session-state is maintained (session-ID created). When re-enabling the Gy session, a new CCR-I is sent immediately (without waiting for data).
 - Response Timeout – When the response timeout happens, if the CCR-I is sent at session-setup and the session-setup timeout happens before response-timeout, then the bearer itself will be terminated. The **diameter send-crri traffic-start** configuration can be used optionally so that the CCR-I timeout does not affect the bearer creation.
 - When the Gy session goes Offline due to CCR-I response timeout and the Gy session is marked Online, the same Session-ID will be used.
 - If the Gy session went offline due to CCR-I error response, the session-information is deleted (next session-ID used will be different).
- In case of rule-movement across bearers (LTE to WiFi or vice-versa) where the Online rule is moved/associated to an existing bearer, the status of the Gy session is not changed.
- The trigger for marking the Offline Gy Session to Online is only based on the Online AVP received from the PCRF in the Charging-Rule-Definition.

Configuring Offline Gy Session after Failure

The following section provides the configuration commands to re-enable the offline Gy session.

Re-enabling Offline Gy Session

Use the following configuration to re-enable offline Gy session after failure.

```

configure
  active-charging service service_name
    credit-control
      [ no ] offline-session re-enable
    end

```

Notes:

- When **offline-session re-enable** is configured and the PCRF installs/modifies a rule with "Online" AVP value set to 1, then the Offline DCCA will be marked Online.
- The default configuration is **no offline-session re-enable**. This feature is disabled by default and when disabled only the **show configuration verbose** command will display this configuration.

Verifying the Configuration

Use the following command to verify the offline/online state transition timestamp:

```
show active-charging sessions full
```

Monitoring and Troubleshooting the Offline Gy Session after Failure

This section provides information regarding show commands and/or their outputs in support of this feature.

The following operations should be performed to troubleshoot any failure related to this feature:

- The CLI output of the **show active-charging sessions full** command can be verified. The "Last State Change Time" field indicates the timestamps at which a session went Offline and came back Online.
- The messages from **monitor subscriber next-call** command can be enabled with "verbosity 3" to analyze the message exchanges happening for the subscriber.
- The "acsmgr" and "debug" level logs can be enabled for further debugging.

show active-charging sessions full

The following new fields are added to the output of this command to display the state transition timestamp:

- Last State Change Time:
 - Offline/Online – The Offline timestamp is updated when the Gy session goes Offline. The Online timestamp is updated when the session is back Online.

Suppress AVPs

This feature adds enhancement to the *Support MVNO Information in Gx, Gy and CDRs* feature.

Feature Description

This feature adds enhancement to the *Support MVNO Information in Gx, Gy and CDRs* feature. SAEGW sends MVNO-Reseller-ID and MVNO-Subclass-ID AVPs in the Gy messages towards the OCS and CDR, whenever these AVPs are received by SAEGW from the PCRF.

With this enhancement, this behavior is now CLI controlled and a new CLI command has been introduced to suppress the AVPs being sent in the Gy interface.

Old Behavior: Reseller-id and subclass-id AVPs were send in Gy when the same were received from PCRF for the ATT dictionary.

New Behavior: New CLI command **suppress_avp** has been added which allows to suppress the Reseller-id and subclass-id AVPs.

Command Changes

suppress_avp

New CLI command has been added to the Credit Control Group configuration mode to suppress the AVPs. Configuring this CLI command would suppress the MVNO-subclass-id and MVNO-Reseller-Id AVPs.

```
configure
  active-charging service <acs_service_name>
  credit-control group <group_name>
    diameter suppress-avp reseller-id subclass-id
    [ no | default ] diameter suppress-avp reseller-id subclass-id
  end
```

Notes:

- **no:** Disables AVP suppression. Whenever PCRF sends the MVNO-subclassid and MVNO-Reseller-id AVPs in the Gx interface, the same is sent in the Gy message.
- **default:** Sets the default configuration. AVPs are not suppressed by default. Whenever PCRF sends the MVNO-subclassid and MVNO-Reseller-id AVPs in the Gx interface, the same is sent in the Gy message.
- **suppress-avp:** Suppresses both MVNO-subclassid and MVNO-Reseller-id AVPs.
- **reseller-id:** Suppresses the MVNO-Reseller-Id AVP.
- **subclass-id:** Suppresses the MVNO-Sub-Class-Id AVP.

Performance Indicator Changes

show configuration

This command has been modified to display the following output:

```
credit-control group default
  diameter origin endpoint sundar
  diameter peer-select peer minid1 secondary-peer minid2
  diameter session failover
  diameter dictionary dcca-custom32
  failure-handling initial-request continue
  failure-handling update-request continue
  diameter dynamic-rules request-quota on-traffic-match
  diameter suppress-avp reseller-id subclass-id
```

Configuring Gy Interface Support

To configure Gy interface support:

-
- Step 1** Configure the core network service as described in this Administration Guide.

- Step 2** Configure Gy interface support as described in the sections [Configuring GGSN / P-GW / IPST Gy Interface Support, on page 373](#) and [Configuring HA / PDSN Gy Interface Support, on page 374](#).
- Step 3** Configure Event-based Gy support as described in [Configuring PLMN and Time Zone Reporting, on page 375](#).
- Step 4** *Optional.* Configure OCS Unreachable Failure Handling Feature or Assume Positive for Gy Feature as described in [Configuring Server Unreachable Feature, on page 376](#).
- Step 5** *Optional.* Configure Static Rulebase for CCR as described in [Configuring Static Rulebase for CCR, on page 377](#).
- Step 6** *Optional.* Configure Gy for GTP based S2a/S2b as described in [Configuring Gy for GTP based S2a/S2b, on page 377](#).
- Step 7** Save your configuration to flash memory, an external memory device, and/or a network location using the Exec mode command **save configuration**. For additional information on how to verify and save configuration files, refer to the *System Administration Guide* and the *Command Line Interface Reference*.

Important Commands used in the configuration examples in this section provide base functionality to the extent that the most common or likely commands and/or keyword options are presented. In many cases, other optional commands and/or keyword options are available. Refer to the *Command Line Interface Reference* for complete information regarding all commands.

Configuring GGSN / P-GW / IPST Gy Interface Support

To configure the standard Gy interface support for GGSN/P-GW/IPST, use the following configuration:

```
configure
  context <context_name>
    diameter endpoint <endpoint_name>
      origin realm <realm>
      origin host <diameter_host> address <ip_address>
      peer <peer> realm <realm> address <ip_address>
    exit
  active-charging service <ecs_service_name>
    credit-control [ group <cc_group_name> ]
      diameter origin endpoint <endpoint_name>
      diameter peer-select peer <peer> realm <realm>
      diameter pending-timeout <timeout_period>
      diameter session failover
      diameter dictionary <dictionary>
      failure-handling initial-request continue
      failure-handling update-request continue
      failure-handling terminate-request continue
    exit
  context <context_name>
    apn <apn_name>
      selection-mode sent-by-ms
      ims-auth-service <service>
      ip access-group <access_list_name> in
      ip access-group <access_list_name> out
      ip context-name <context_name>
      active-charging rulebase <rulebase_name>
```

```

credit-control-group <cc_group_name>
end

```

Notes:

- For information on configuring IP access lists, refer to the *Access Control Lists* chapter in the *System Administration Guide*.
- For more information on configuring ECS ruledefs, refer to the *ACS Ruledef Configuration Mode Commands* chapter in the *Command Line Interface Reference*.
- For more information on configuring ECS charging actions, refer to the *ACS Charging Action Configuration Mode Commands* chapter in the *Command Line Interface Reference*.
- For more information on configuring ECS rulebases, refer to the *ACS Rulebase Configuration Mode Commands* chapter in the *Command Line Interface Reference*.

Configuring HA / PDSN Gy Interface Support

To configure HA / PDSN Gy interface support, use the following configuration:

```

configure
  context <context_name>
    diameter endpoint <endpoint_name>
      origin realm <realm>
      origin host <diameter_host> address <ip_address>
      peer <peer> realm <realm> address <ip_address>
      exit
    exit
  active-charging service <ecs_service_name>
    ruledef <ruledef_name>
      ip any-match = TRUE
      exit
    charging-action <charging_action_name>
      content-id <content_id>
      cca charging credit rating-group <rating_group>
      exit
    rulebase <rulebase_name>
      action priority <action_priority> ruledef <ruledef_name>
charging-action <charging_action_name>
  exit
  credit-control [ group <cc_group_name> ]
    diameter origin endpoint <endpoint_name>
    diameter peer-select peer <peer> realm <realm>
    diameter pending-timeout <timeout>
    diameter session failover
    diameter dictionary <dictionary>
    failure-handling initial-request continue
    failure-handling update-request continue
    failure-handling terminate-request continue
    pending-traffic-treatment noquota buffer
    pending-traffic-treatment quota-exhausted buffer
  exit

```

```

exit
context <context_name>
  subscriber default
    ip access-group <acl_name> in
    ip access-group <acl_name> out
    ip context-name <context_name>
    active-charging rulebase <rulebase_name>

    credit-control-group <cc_group_name>
  end

```

Notes:

- For information on configuring IP access lists, refer to the *Access Control Lists* chapter in the *System Administration Guide*.
- For more information on configuring ECS ruledefs, refer to the *ACS Ruledef Configuration Mode Commands* chapter in the *Command Line Interface Reference*.
- For more information on configuring ECS charging actions, refer to the *ACS Charging Action Configuration Mode Commands* chapter in the *Command Line Interface Reference*.
- For more information on configuring ECS rulebases, refer to the *ACS Rulebase Configuration Mode Commands* chapter in the *Command Line Interface Reference*.

Configuring PLMN and Time Zone Reporting

PLMN and Time Zone Reporting feature requires a credit-control group to be defined in the APN or subscriber configuration or there must be a default credit-control group configured. The following CLI commands are available to enable/disable PLMN and Time Zone Reporting feature.

To enable PLMN and Time Zone Reporting through subscriber-template, use the following configuration:

```

configure
  context <context_name>
    subscriber name <subscriber_name>
      dns primary <primary_ipaddress>
      dns secondary <secondary_ipaddress>
      ip access-group test in
      ip access-group test out
      ip context-name <context_name>
      credit-control-client event-based-charging
      active-charging rulebase <rulebase_name>
    exit
  end

```

Notes:

- The **credit-control-client event-based-charging** command should be used to enable PLMN and Time Zone Reporting.
- For more information on configuring PLMN and Time Zone Reporting feature, refer to the *Command Line Interface Reference*.

To enable PLMN and Time Zone Reporting through APN template, use the following configuration:

```

configure
  context <context_name>
    apn <apn_name>
      selection-mode sent-by-ms
      accounting-mode none
      ip access-group test in
      ip access-group test out
      ip context-name <context_name>
      ip address pool name<pool_name>
      credit-control-client event-based-charging
      active-charging rulebase <rulebase_name>
      exit
    end
  end

```

Rest of the parameters needed for Event-based Gy such as dictionary, endpoint will be picked from the credit-control group.

In a scenario where the triggers are configured through the CLI command and another set of triggers are also received from Gx, then the triggers from Gx will have a higher priority.

Configuring Server Unreachable Feature

The Server Unreachable feature requires a failure handling behavior to be defined in the Diameter Credit Control configuration. The following CLI commands are available to enable/disable OCS Unreachable Failure Handling feature.

To enable OCS Unreachable Failure Handling feature, use the following configuration:

```

configure
require active-charging
  active-charging service <service_name>
  credit-control
    servers-unreachable { initial-request | update-request
  } { continue | terminate } [ { after-interim-volume <bytes> |
after-interim-time <seconds> } + server-retries <retry_count> ]
    servers-unreachable behavior-triggers { initial-request
| update-request } transport-failure [ response-timeout | tx-expiry ]
    servers-unreachable behavior-triggers initial-request
{ result-code { any-error | result-code [ to end-result-code ] } }
    servers-unreachable behavior-triggers update-request
{ result-code { any-error | result-code [ to end-result-code ] } }
  end

```



Important

After you configure **configure**, **require active-charging**, **active-charging service <service_name>**, and **credit-control** CLI commands, you must save the configuration and then reload the chassis for the command to take effect. For information on saving the configuration file and reloading the chassis, refer to the *System Administration Guide* for your deployment.

Notes:

- This CLI command **servers-unreachable { initial-request | update-request } { continue | terminate } [{ after-interim-volume ... }** allows configuring interim-volume and interim-time in the following ways:
 - after-interim-volume <bytes> alone followed by server-retries.
 - after-interim-time <secs> alone followed by server-retries.
 - after-interim-volume <bytes> after-interim-time <secs> followed by server-retries.
- This CLI command **servers-unreachable behavior-triggers** is used to trigger the servers-unreachable failure handling at either Tx expiry or Response timeout (This CLI is similar to retry-after-tx-expiry in **failure-handling update-request continue retry-after-tx-expiry** command.).
- This CLI command **servers-unreachable behavior-triggers initial-request { result-code { any-error | result-code [to end-result-code] } }** is used to trigger the servers-unreachable failure handling based on the configured Diameter error result codes.

For more information on configuring this feature, refer to the *Command Line Interface Reference*.

Configuring Static Rulebase for CCR

To allow static configuration of rulebase name to be passed to OCS via CCR message, use the following configuration:

```
configure
  require active-charging
  active-charging service service_name
    credit-control group ccgroup_name
      charging-rulebase-name rulebase_name
    no charging-rulebase-name
  end
```



Important

After you configure **configure**, **require active-charging**, **active-charging service service_name**, and **credit-control group ccgroup_name** CLI commands, you must save the configuration and then reload the chassis for the command to take effect. For information on saving the configuration file and reloading the chassis, refer to the *System Administration Guide* for your deployment.

Notes:

- By default, the rulebase obtained from APN/subscriber template will be sent to OCS through the CCR message.

For more information on configuring this feature, refer to the *Command Line Interface Reference*.

Configuring Gy for GTP based S2a/S2b

To provide Gy Support for WiFi integration in P-GW for GTP based S2a/S2b, use the following configuration:

```
configure
  require active-charging
  active-charging service service_name
    credit-control group ccgroup_name
```

```
diameter update-dictionary-avps 3gpp-rel11
[ default | no ] diameter update-dictionary-avps
end
```

Notes:

- **3gpp-rel11**: Provides support for 3GPP Rel.11 specific AVPs in the standard Gy dictionary.

Gathering Statistics

This section explains how to gather Gy related statistics and configuration information.

In the following table, the first column lists what statistics to gather, and the second column lists the action to perform.

Statistics/Information	Action to perform
Complete statistics for ECS sessions.	show active-charging sessions full
Detailed information for the Active Charging Service (ACS)	show active-charging service all
Information on all rule definitions configured in the service.	show active-charging ruledef all
Information on all charging actions configured in the service.	show active-charging charging-action all
Information on all rulebases configured in the service.	show active-charging rulebase all
Statistics of the Credit Control application, DCCA.	show active-charging credit-control statistics
States of the Credit Control application's sessions, DCCA.	show active-charging credit-control session-states [rulebase <rulebase_name>] [content-id <content_id>]



APPENDIX

IP Header Compression

This chapter provides information on configuring an enhanced, or extended, service. The product administration guides provide examples and procedures for configuration of basic services on the system. It is recommended that you select the configuration example that best meets your service model, and configure the required elements for that model, as described in the respective product administration guide, before using the procedures in this chapter.



Important

RoHC header compression is not applicable for SGSN and GGSN services.

- [Overview, on page 379](#)
- [Configuring VJ Header Compression for PPP, on page 380](#)
- [Configuring RoHC Header Compression for PPP, on page 381](#)
- [Configuring Both RoHC and VJ Header Compression, on page 382](#)
- [Configuring RoHC for Use with SO67 in PDSN or HSGW Service, on page 384](#)
- [Using an RoHC Profile for Subscriber Sessions, on page 385](#)
- [Disabling VJ Header Compression Over PPP, on page 388](#)
- [Disabling RoHC Header Compression Over SO67, on page 389](#)
- [Checking IP Header Compression Statistics, on page 390](#)
- [RADIUS Attributes for IP Header Compression, on page 391](#)

Overview

The system supports IP header compression on the PPP tunnels established over the EVDO-RevA A10 links and also over the GRE tunnel that is connected to the PCF to support EVDO-RevA Service Option 67 (SO67).

By default IP header compression using the VJ algorithm is enabled for subscribers using PPP.

Note that you can use the default VJ header compression algorithm alone, configure the use of RoHC header compression only, or use both VJ and RoHC IP header compression.

- **Van Jacobsen (VJ)** - The RFC 1144 (CTCP) header compression standard was developed by V. Jacobson in 1990. It is commonly known as VJ compression. It describes a basic method for compressing the headers of IPv4/TCP packets to improve performance over low speed serial links.
- **RObust Header Compression (RoHC)** - The RFC 3095 (RoHC) standard was developed in 2001. This standard can compress IP/UDP/RTP headers to just over one byte, even in the presence of severe channel

impairments. This compression scheme can also compress IP/UDP and IP/ESP packet flows. RoHC is intended for use in wireless radio network equipment and mobile terminals to decrease header overhead, reduce packet loss, improve interactive response, and increase security over low-speed, noisy wireless links.



Important

The RoHC is a licensed Cisco feature. A separate feature license may be required. Contact your Cisco account representative for detailed information on specific licensing requirements. For information on installing and verifying licenses, refer to the *Managing License Keys* section of the *Software Management Operations* chapter in the *System Administration Guide*.

In addition, you can configure RoHC profiles that define RoHC Compressor and Decompressor parameters. These RoHC profiles can be applied to subscribers.

You can also turn off all IP header compression for a subscriber.

The procedures in this chapter describe how to configure the IP header compression methods used, but for RoHC over PPP the Internet Protocol Control Protocol (IPCP) negotiations determine when they are used.

Implementing IP header compression provides the following benefits:

- Improves interactive response time
- Allows the use of small packets for bulk data with good line efficiency
- Allows the use of small packets for delay sensitive low data-rate traffic
- Decreases header overhead.
- Reduces packet loss rate over lossy links.

Configuring VJ Header Compression for PPP

By default, VJ IP header compression is enabled for subscriber sessions. When VJ header compression is configured all IP headers are compressed using the VJ compression algorithm.

Note that procedure described in this section is applicable only when VJ header compression is disabled.



Important

This section provides the minimum instruction set for configuring subscriber profile for header compression. For more information on commands that configure additional parameters and options, refer *Subscriber Configuration Mode Commands* chapter in *Command Line Interface Reference*.

To configure the system to enable VJ header compression to IP headers:

- Step 1** Enable VJ header compression by applying the example configuration in [Enabling VJ Header Compression, on page 381](#).
- Step 2** Verify your VJ header compression configuration by following the steps in [Verifying the VJ Header Compression Configuration, on page 389](#).

- Step 3** Save your configuration to flash memory, an external memory device, and/or a network location using the Exec mode command **save configuration**. For additional information on how to verify and save configuration files, refer to the *System Administration Guide* and the *Command Line Interface Reference*.
-

Enabling VJ Header Compression

Use the following example to enable the VJ header compression over PPP:

```
configure
  context <ctxt_name>
    subscriber name <subs_name>
      ip header-compression vj
    end
```

Notes:

- *<ctxt_name>* is the system context in which you wish to configure the subscriber profile. Typically this is an AAA context.
- *<subs_name>* is the name of the subscriber in the current context that you want to enable VJ IP header compression for.

Verifying the VJ Header Compression Configuration

These instructions are used to verify the VJ header compression configuration.

Verify that your header compression configurations for subscriber by entering the following command in Exec Mode in specific context:

```
show subscriber configuration username subs_name
```

The output of this command is a concise listing of subscriber parameter settings as configured.

Configuring RoHC Header Compression for PPP

RoHC IP header compression can be configured for all IP traffic, uplink traffic only, or downlink traffic only. When RoHC is configured for all traffic, you can specify the mode in which RoHC is applied.



Important

This section provides the minimum instruction set for configuring subscriber profile for header compression. For more information on commands that configure additional parameters and options, refer *Subscriber Configuration Mode Commands* chapter in the *Command Line Interface Reference*.

To configure the system to enable RoHC header compression to IP headers:

- Enable RoHC header compression by applying the example configuration in [Enabling RoHC Header Compression for PPP, on page 382](#).
- Verify your RoHC header compression configuration by following the steps in [Verifying the Header Compression Configuration, on page 382](#).
- Save your configuration to flash memory, an external memory device, and/or a network location using the Exec mode command **save configuration**. For additional information on how to verify and save configuration files, refer to the *System Administration Guide* and the *Command Line Interface Reference*.

Enabling RoHC Header Compression for PPP

Use the following example to enable the RoHC over PPP:

```
configure
  context <ctxt_name>
    subscriber name <subs_name>
      ip header-compression RoHC [ any [ mode { optimistic |
reliable | unidirectional } ] | cid-mode { { large | small } [
marked-flows-only | max-cid | max-hdr <value> | mrru <value> ] } | marked
flows-only | max-hdr <value> | mrru <value> | downlink | uplink ] }+
    end
```

Notes:

- *<ctxt_name>* is the system context in which you wish to configure the subscriber profile. Typically this is an AAA context.
- *<subs_name>* is the name of the subscriber in the current context that you want to enable RoHC header compression for.
- Refer to the *Subscriber Configuration Mode Commands* chapter in *Command Line Interface Reference* for more details on this command and its options.

Verifying the Header Compression Configuration

These instructions are used to verify the header compression configuration.

Verify that your header compression configurations for subscriber by entering the following command in Exec Mode in specific context:

```
show subscriber configuration username subs_name
```

The output of this command is a concise listing of subscriber parameter settings as configured.

Configuring Both RoHC and VJ Header Compression

You can configure the system to use both VJ and RoHC IP header compression. When both VJ and RoHC are specified, the optimum header compression algorithm for the type of data being transferred is used for data in the downlink direction.



Important If both RoHC and VJ header compression are specified, the optimum header compression algorithm for the type of data being transferred is used for data in the downlink direction.



Important This section provides the minimum instruction set for configuring subscriber profile for header compression. For more information on commands that configure additional parameters and options, refer *Subscriber Configuration Mode Commands* chapter in the *Command Line Interface Reference*.

To configure the system to enable both RoHC and VJ header compression to IP headers:

- Enable the RoHC and VJ header compression by applying the example configuration in [Enabling RoHC and VJ Header Compression for PPP, on page 383](#).
- Verify your RoHC and VJ header compression configuration by following the steps in [Verifying the Header Compression Configuration, on page 383](#).
- Save your configuration to flash memory, an external memory device, and/or a network location using the Exec mode command **save configuration**. For additional information on how to verify and save configuration files, refer to the *System Administration Guide* and the *Command Line Interface Reference*.

Enabling RoHC and VJ Header Compression for PPP

Use the following example to enable the header compression over PPP:

```
configure
  context <ctxt_name>
    subscriber name <subs_name>
      ip header-compression vj RoHC [ any [ mode { optimistic |
reliable | unidirectional } ] | cid-mode { { large | small } [
marked-flows-only | max-cid | max-hdr <value> | mrru <value> ] } | marked
flows-only | max-hdr <value> | mrru <value> | downlink | uplink ] ]+
    end
```

Notes:

- *<ctxt_name>* is the system context in which you wish to configure the subscriber profile. Typically this is an AAA context.
- *<subs_name>* is the name of the subscriber in the current context that you want to enable RoHC header compression for.
- Refer to the Subscriber Configuration Mode Commands chapter in Command Line Interface Reference for more details on this command and its options.

Verifying the Header Compression Configuration

These instructions are used to verify the header compression configuration.

Verify that your header compression configurations for subscriber by entering the following command in Exec Mode in specific context:

```
show subscriber configuration username subs_name
```

The output of this command is a concise listing of subscriber parameter settings as configured.

Configuring RoHC for Use with SO67 in PDSN or HSGW Service

This section explains how to set RoHC settings in the PDSN or HSGW Service configuration mode. These settings are transferred to the PCF during the initial A11 setup and are used for the GRE tunnel that is connected to the PCF to support EVDO-RevA Service Option 67 (SO67). RoHC is enabled through an auxiliary SO67 A10 connection and the PCF signals this information when the auxiliary A10 is connected.



Important This section provides the minimum instruction set for configuring subscriber profile for header compression. For more information on commands that configure additional parameters and options, refer *PDSN Service Configuration Mode Commands* or *HSGW Service Configuration Mode Commands* chapter in *Command Line Interface Reference*.

To configure the system to enable the RoHC header compression feature at the PDSN or HSGW Service over SO67:

- Step 1** Enable header compression by applying the example configuration in [Enabling RoHC Header Compression with PDSN, on page 384](#) or [Enabling ROHC Header Compression with HSGW section](#).
- Step 2** Verify your RoHC configuration by following the steps in [Verifying the Header Compression Configuration, on page 385](#).
- Step 3** Save your configuration to flash memory, an external memory device, and/or a network location using the Exec mode command **save configuration**. For additional information on how to verify and save configuration files, refer to the *System Administration Guide* and the *Command Line Interface Reference*.

Enabling RoHC Header Compression with PDSN

Use the following example to enable the RoHC header compression with PDSN over SO67:

```
configure
  context <ctxt_name>
    pdsn-service <svc_name>
      ip header-compression rohc
      cid-mode {large | small} max-cid integer
      mrru <num_octets>
      profile { [esp-ip] [rtp-udp] [udp-ip] [uncompressed-ip] }
    end
```

Notes:

- *<ctxt_name>* is the system context in which PDSN service is configured and you wish to configure the service profile.

- `<svc_name>` is the name of the PDSN service in which you want to enable RoHC over SO67.
- Refer to the *PDSN Service RoHC Configuration Mode Commands* chapter in *Command Line Interface Reference* for more details on this command and its options.

Enabling RoHC Header Compression with HSGW

Use the following example to enable the RoHC header compression with HSGW over SO67:

```
configure
  context <ctxt_name>
    hsgw-service <svc_name>
      ip header-compression rohc
        cid-mode {large | small} max-cid integer
        mrru <num_octets>
        profile { [esp-ip] [rtp-udp] [udp-ip] [uncompressed-ip]
      }
    end
```

Notes:

- `<ctxt_name>` is the system context in which HSGW service is configured and you wish to configure the service profile.
- `<svc_name>` is the name of the HSGW service in which you want to enable RoHC over SO67.
- Refer to the *HSGW Service RoHC Configuration Mode Commands* chapter in *Command Line Interface Reference* for more details on this command and its options.

Verifying the Header Compression Configuration

These instructions are used to verify the header compression configuration.

Verify that your header compression configurations for subscriber by entering the following command in Exec Mode in specific context:

```
show configuration context ctxt_name
```

The output of this command is a concise listing of subscriber parameter settings as configured.

Using an RoHC Profile for Subscriber Sessions

You can configure RoHC profiles that specify numerous compressor and decompressor settings. These profiles can in turn be applied to a specific subscriber or the default subscriber. RoHC profiles are used for both RoHC over PPP and for RoHC over SO67.



Important This section provides the minimum instruction set for configuring subscriber profile for header compression. For more information on commands that configure additional parameters and options, refer *Subscriber Configuration Mode Commands* chapter in *Command Line Interface Reference*.

To configure the system to apply RoHC profile to a subscriber session:

- Step 1** Create RoHC profile using decompression mode or decompression mode. If you want to use compression mode go to step a else follow step b:
- Configure RoHC profile by applying the example configuration in the [Creating RoHC Profile for Subscriber using Compression Mode, on page 386](#) using compression mode.
 - Alternatively configure RoHC profile by applying the example configuration in the [Creating RoHC Profile for Subscriber using Decompression Mode, on page 387](#) using compression mode.
- Step 2** Apply existing RoHC profile to a subscriber by applying the example configuration in the [Applying RoHC Profile to a Subscriber, on page 387](#).
- Step 3** Verify your RoHC header compression configuration by following the steps in the [Verifying the Header Compression Configuration, on page 388](#).
- Step 4** Save your configuration to flash memory, an external memory device, and/or a network location using the Exec mode command **save configuration**. For additional information on how to verify and save configuration files, refer to the *System Administration Guide* and the *Command Line Interface Reference*.

Creating RoHC Profile for Subscriber using Compression Mode

Use the following example to create RoHC profile for a subscriber using compression mode:

```
configure
  RoHC-profile profile-name <RoHC_comp_profile_name>
    decompression-options
      [no] multiple-ts-stride
      rtp-sn-p <p_value>
      [no] use-ipid-override
      [no] use-optimized-talkspurt
      [no] use-optimized-transience
      [no] use-timer-based-compression
    end
```

Notes:

- *<RoHC_comp_profile_name>* is the name of the RoHC profile with compression mode which you want to apply to a subscriber.
- System configured most of the parameters by default. For more information on other options and parameters and details, refer to the *RoHC Profile Compression Configuration Mode Commands* chapter in *Command Line Interface Reference*.

Creating RoHC Profile for Subscriber using Decompression Mode

Use the following example to create RoHC profile for a subscriber using decompression mode:

```

configure
  RoHC-profile profile-name <RoHC_decomp_profile_name>
    decompression-options
      context-timeout <dur>
      max-jitter-cd <dur_ms>
      nak-limit <limit>
      optimistic-mode-ack
      optimistic-mode-ack-limit <num_pkts>
      piggyback-wait-time <dur_ms>
      preferred-feedback-mode { bidirectional-optimistic |
bidirectional-reliable | unidirectional }
      rtp-sn-p <p_value>
      [no] rtp-sn-p-override
      [no] use-clock-option
      [no] use-crc-option
      [no] use-feedback
      [no] use-jitter-option
      [no] use-reject-option
      [no] use-sn-option
    end

```

Notes:

- <RoHC_profile_name> is the name of the RoHC profile with decompression mode which you want to apply to a subscriber.
- System configured most of the parameters by default. For more information on other options and parameters and details, refer to the *RoHC Profile Decompression Configuration Mode Commands* chapter in *Command Line Interface Reference*.

Applying RoHC Profile to a Subscriber

Once an RoHC profile has been created that profile can be specified to be used for a specific subscribers. Use the following example to apply the RoHC profile to a subscriber:

```

configure
  context <ctxt_name>
    subscriber name <subs_name>
      RoHC-profile-name <RoHC_profile_name>
    end

```

Notes:

- <ctxt_name> is the system context in which you wish to configure the subscriber profile. Typically this is an AAA context.
- <subs_name> is the name of the subscriber in the current context that you want to enable RoHC header compression for.

- `<RoHC_profile_name>` is the name of the existing RoHC profile (created with compressed or decompressed mode) which you want to apply to a subscriber in the current context.
- Refer to the *Subscriber Configuration Mode Commands* chapter in *Command Line Interface Reference* for more details on this command and its options.

Verifying the Header Compression Configuration

These instructions are used to verify the header compression configuration.

Verify that your header compression configurations for subscriber by entering the following command in Exec Mode in specific context:

```
show subscriber configuration username subs_name
```

The output of this command is a concise listing of subscriber parameter settings as configured.

Disabling VJ Header Compression Over PPP

By default, VJ IP header compression is enabled for subscriber sessions. When VJ header compression is configured all IP headers are compressed using the VJ compression algorithm.

If you do not want to apply compression to any IP headers for a subscriber session you can disable the IP header compression feature.



Important

This section provides the minimum instruction set for configuring subscriber profile for header compression. For more information on commands that configure additional parameters and options, refer *Subscriber Configuration Mode Commands* chapter in *Command Line Interface Reference*.

To configure the system to disable VJ header compression to IP headers:

- Step 1** Disable header compression by applying the example configuration in [Disabling VJ Header Compression, on page 388](#).
- Step 2** Verify your VJ header compression configuration by following the steps in [Verifying the VJ Header Compression Configuration, on page 389](#).
- Step 3** Save your configuration to flash memory, an external memory device, and/or a network location using the Exec mode command **save configuration**. For additional information on how to verify and save configuration files, refer to the *System Administration Guide* and the *Command Line Interface Reference*.

Disabling VJ Header Compression

Use the following example to disable the VJ header compression over PPP:

```
configure
  context <ctxt_name>
    subscriber name <subs_name>
      no ip header-compression
    end
```

Notes:

- <ctxt_name> is the system context in which you wish to configure the subscriber profile. Typically this is an AAA context.
- <subs_name> is the name of the subscriber in the current context that you want to disable IP header compression for.

Verifying the VJ Header Compression Configuration

These instructions are used to verify the VJ header compression configuration.

Verify that your header compression configurations for subscriber by entering the following command in Exec Mode in specific context:

```
show subscriber configuration username <subs_name>
```

The output of this command is a concise listing of subscriber parameter settings as configured.

Disabling RoHC Header Compression Over S067

If you do not want to apply compression to any IP headers for a subscriber sessions using the EVDO-RevA S067 feature, you can disable the IP header compression feature at the PDSN or HSGW Service.



Important

This section provides the minimum instruction set for configuring subscriber profile for header compression. For more information on commands that configure additional parameters and options, refer *PDSN Service Configuration Mode Commands* or *HSGW Service Configuration Mode Commands* chapter in *Command Line Interface Reference*.

To configure the system to disable the IP header compression feature at the PDSN or HSGW Service:

-
- Step 1** Disable header compression by applying the example configuration in [Disabling RoHC Header Compression, on page 390](#).
- Step 2** Verify your RoHC configuration by following the steps in [Verifying the Header Compression Configuration, on page 390](#).
- Step 3** Save your configuration to flash memory, an external memory device, and/or a network location using the Exec mode command **save configuration**. For additional information on how to verify and save configuration files, refer to the *System Administration Guide* and the *Command Line Interface Reference*.
-

Disabling RoHC Header Compression

Use the following example to disable the header compression over SO67:

```
configure
  context <ctxt_name>
    pdsn/hsgw-service <svc_name>
      no ip header-compression RoHC
    end
```

Notes:

- <ctxt_name> is the system context in which PDSN or HSGW service is configured and you wish to configure the service profile.
- <svc_name> is the name of the PDSN or HSGW service in which you want to disable RoHC over SO67.

Verifying the Header Compression Configuration

These instructions are used to verify the header compression configuration.

Verify that your header compression configurations for subscriber by entering the following command in Exec Mode in specific context:

```
show configuration context <ctxt_name>
```

The output of this command is a concise listing of subscriber parameter settings as configured.

Checking IP Header Compression Statistics

This section commands to use to retrieve statistics that include IP header compression information.

The following Exec mode commands can be used to retrieve IP header compression statistics:

- monitor protocol ppp
- show ppp
- show ppp statistics
- show RoHC statistics
- show RoHC statistics pdsn-service
- show subscriber full username

For more information on these commands, refer to the *Command Line Interface Reference*.

RADIUS Attributes for IP Header Compression

This section lists the names of the RADIUS attributes to use for RoHC header compression. For more information on these attributes, refer to the AAA Interface Administration and Reference.

One of the following attributes can be used to specify the name of the RoHC profile to use for the subscriber session:

- SN-RoHC-Profile-Name
- SN1-RoHC-Profile-Name

Any RoHC parameters not specified in the RoHC profile are set to their default values.



APPENDIX J

IP Pool Sharing Protocol

This chapter provides information on configuring an enhanced, or extended, service. The product administration guides provide examples and procedures for configuration of basic services on the system. It is recommended that you select the configuration example that best meets your service model, and configure the required elements for that model before using the procedures in this chapter.

This chapter contains the following topics:

- [Overview, on page 393](#)
- [How IPSP Works, on page 395](#)
- [Configuring IPSP Before the Software Upgrade, on page 398](#)
- [Configuring IPSP After the Software Upgrade, on page 400](#)
- [Disabling IPSP, on page 401](#)

Overview

The IP Pool Sharing Protocol (IPSP) is a protocol that system-based HA services can use during an offline-software upgrade to avoid the assignment of duplicate IP addresses to sessions while allowing them to maintain the same address, and to preserve network capacity.

In order for IPSP to be used, at least two system-based HAs with identical configurations must be present on the same LAN. IPSP uses a primary & secondary model to manage the IP pools between the HAs. When used, this protocol ensures the following:

- In-progress sessions can be handed-off to the secondary HA when an offline-software upgrade is being performed on the primary and receive the same IP address that it was originally assigned.
- New sessions can be redirected to the secondary HA when an offline-software upgrade is being performed on the primary and receive a non-duplicate IP address.

The protocol is enabled at the interface level. Each system-based HA must have an IPSP-enabled interface configured in the same context as the HA service for this protocol to function properly.

Primary HA Functionality

The primary HA is the system that is to be upgraded. It performs the following functions for IPSP:

- Queries the pool information from the secondary HA the pool configurations on both HAs must be identical

- Assigns an IP address or address block to the secondary HA when requested by the secondary HA the primary HA releases sessions if they have an IP address requested by the secondary
- For graceful termination conditions (e.g. an administrative user issues the **reload** command), sends a termination message to the secondary HA causing it to assume the responsibilities of the primary HA until the primary is available again.
- Sends a trap when the number of calls drops to zero after starting IPSP

Secondary HA Functionality

The secondary HA is the system that takes over Mobile IP sessions from the primary HA that is being upgraded. It performs the following functions for IPSP:

- Locks the IP pools until it receives an address or address block assignment from the primary HA it unlocks the IP pools after busying out the addresses that are not assigned to it
- Processes address requests for sessions that are within the address block assigned to it
- Communicates with the primary HA, as needed, to request IP addresses that are not currently assigned to it it does not assign the address until the primary HA approves it
- For graceful termination conditions (e.g. an administrative user issues the **reload** command), it notifies the primary HA that it is going out of service
- Assumes the responsibility of the primary HA when requested to
- In the event that it determines that primary HA is not available, it assumes the responsibility of the primary HA if there is at least one address allocated to verify that the AAA server is re-configured to direct the calls

Requirements, Limitations, & Behavior

- One IPSP interface can be configured per system context.
- The IPSP interfaces for both the primary and secondary HAs must be configured to communicate on the same network.
- If IP pool busyout is enabled on any configured address pool, IPSP can not be configured.
- The IP pool configuration (pool name, addresses, priority, pool group, etc.) on both the HAs must be identical.
- IP pools cannot be modified on either the primary or the secondary HAs once IPSP is enabled.
- Sessions are dropped during the IPSP setup process if:
 - the primary HA has not yet approved an IP address or address block.
 - the primary HA is not known to the secondary HA.
- Once an address is assigned to the secondary HA, all the information about that address is erased on the primary HA and that address becomes unusable by the primary HA.
- LRU is not supported across the systems. Although, LRU continues to be supported within the system.

- If the IPSP configuration is not disabled before removing the HA from the IPSP network link, sessions may be rejected if the system's VPN Manager is rebooted or restarts.
- IPSP does not control static IP pools. An external application (AAA, etc.) must be responsible for ensuring that duplicate addresses are not assigned.
- IPSP ignores interface failures allowing the configured dead-interval timer to determine when the HA should become the primary and control the pool addresses. Before the dead-interval timer starts, the secondary HA maintains its state and any busied out addresses remain busied out. After the dead-interval timer starts, IPSP marks the neighboring peer HA as down, becomes primary, and will unbusy out all pool addresses.

How IPSP Works

IPSP operation requires special configuration in both the primary and secondary HAs. As mentioned previously, both HAs must have identical configurations. This allows the secondary HA to process sessions identically to the primary when the primary is taken offline for upgrade.

Configuration must also be performed on the AAA server. Whereas subscriber profiles on the AAA server originally directed sessions to the primary HA, prior to using IPSP, subscriber profiles must be re-configured to direct sessions to the secondary HA.

There are two scenarios in which IPSP takes effect:

- **New sessions:** Once IPSP is configured, new sessions are directed to a secondary HA (HA2) allowing the primary HA to go through a software upgrade without degrading network capacity. The secondary HA requests addresses from the primary HA's (HA1) pools as needed. As the addresses are allocated, they are busied out on the primary HA. This procedure is displayed below.
- **Session handoffs:** Once IPSP is configured, sessions originally registered with the primary HA (HA1) are re-registered with the secondary HA (HA2). To ensure the session is assigned the same IP address, the secondary HA requests the address from the primary HA. The primary HA verifies the binding and releases it to the secondary HA which, in turn, re-assigns it to the session. As the addresses are allocated, they are busied out on the primary HA. This procedure is displayed below.

IPSP Operation for New Sessions

The following figure and text describe how new sessions are handled when IPSP is enabled.

Figure 36: IPSP Operation for New Sessions

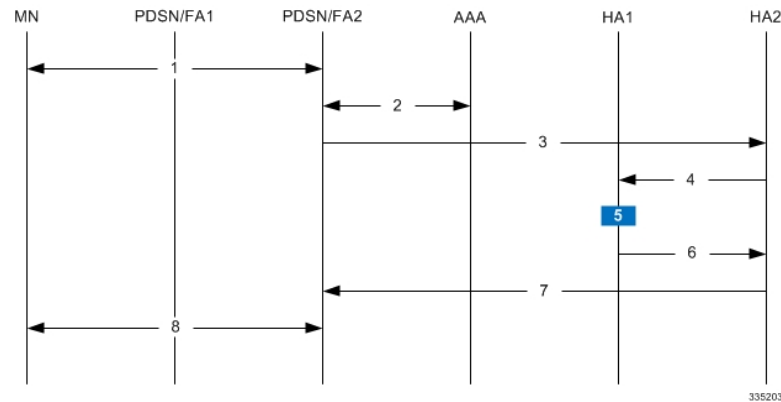

Table 42: IPSP Operation for New Sessions Description

Step	Description
1	A mobile node (MN) attempting to establish a data session is connected to PDSN/FA 2.
2	PDSNFA 2 authenticates the subscriber with the AAA server. One of the attributes returned by the AAA server as part of a successful authentication is the IP address of the secondary HA.
3	PDSN/FA 2 forwards the session request to HA2 for processing. HA2 processes the session as it would for any Mobile IP session.
4	With IPSP enabled, prior to assigning an IP address, HA2 sends a request to HA1 for an IP address.
5	HA1 allocates the address to HA2 and busies it out so it can not be re-assigned.
6	HA1 responds to HA2 with the IP address for the session.
7	HA2 proceeds with session processing and provides PDSN/FA 2 with the IP address for the MN.
8	The MN and PDSN/FA 2 complete session processing.

IPSP Operation for Session Handoffs

The following figure and text describe how session handoffs are handled when IPSP is enabled.

Figure 37: IPSP Operation for Session Handoffs

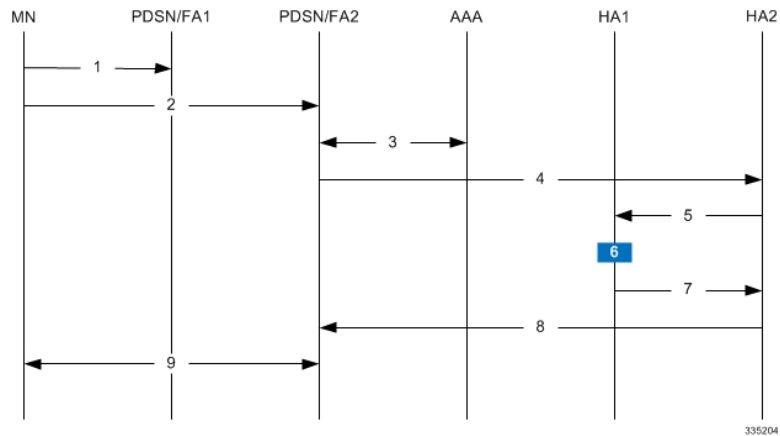

Table 43: IPSP Operation for Session Handoffs Description

Step	Description
1	A mobile node (MN) is connected to PDSN/FA 1.
2	The MN's session is handed-off to PDSN/FA2 and goes through the re-registration process.
3	PDSN/FA 2 authenticates the subscriber with the AAA server as part of the re-registration process. One of the attributes returned by the AAA server as part of a successful authentication is the IP address of the secondary HA.
4	PDSN/FA 2 forwards the session request to HA2 for processing. Included in the request is the MN's current IP address.
5	With IPSP enabled, prior to assigning an IP address, HA2 sends a request to HA1 for an IP address.
6	HA1 verifies the MN's information and releases the binding. It then busies out the address so it can not be re-assigned.
7	HA1 allocates the original IP address to HA2 for the session.
8	HA2 proceeds with session processing and provides PDSN/FA 2 with the IP address for the mobile node.
9	The mobile node and PDSN/FA 2 complete session processing.

Configuring IPSP Before the Software Upgrade

Configuring IPSP requires changes to the primary HA (the HA on which the software upgrade is to occur), the secondary HA (the HA to which subscribers sessions are to be directed), and the AAA server.

This section provides information and instructions for configuring IPSP before the software upgrade.



Important This section provides the minimum instruction set for configuring IPSP on the system. For more information on commands that configure additional parameters and options, refer to the *IPSP Configuration Mode Commands* chapter in the *Command Line Interface Reference*.

To enable the IP pool sharing during software upgrade:

-
- Step 1** Configure the AAA servers by applying the example configuration in [Configuring the AAA Server for IPSP, on page 398](#).
 - Step 2** Configure an interface on the system for use by IPSP according to the instructions found in the *Creating and Configuring Ethernet Interfaces and Ports* section of the *System Administration Guide*.
 - Step 3** Enable the IPSP on secondary HA by applying the example configuration in [Enabling IPSP on the Secondary HA, on page 399](#).
 - Step 4** Perform the boot system priority and SPC/SMC card synchronization as described in *Off-line Software Upgrade* section in the *System Administration Guide*.
 - Step 5** Enable the IPSP on primary HA by applying the example configuration in [Enabling IPSP on the Primary HA, on page 399](#).
 - Step 6** Verify your ACL configuration by following the steps in the *Verifying the IPSP Configuration* section.
 - Step 7** Proceed for software upgrade as described in *Off-line Software Upgrade* section in the *System Administration Guide*.
 - Step 8** Save your configuration to flash memory, an external memory device, and/or a network location using the Exec mode command **save configuration**. For additional information on how to verify and save configuration files, refer to the *System Administration Guide* and the *Command Line Interface Reference*.
-

Configuring the AAA Server for IPSP

For subscriber session establishment, the AAA server provides the IP address of the HA that is to service the session. This information exists in the 3GPP2_MIP_HA_Address RADIUS attribute configured for the subscriber.

Because the primary HA has been responsible for facilitating subscriber sessions, its IP address is the one configured via this attribute. For IPSP however, the attribute configuration must change in order to direct sessions to the secondary HA.

To do this, reconfigure the 3GPP2_MIP_HA_Address RADIUS attribute for each subscriber on the AAA server with the IP address of the secondary HA.

The precise instructions for performing this operation vary depending on the AAA server vendor. Refer to the documentation for your AAA server for more information.

Enabling IPSP on the Secondary HA

The secondary HA is the alternate HA that is to take responsibility while the primary HA is upgraded.



Important

This section provides the minimum instruction set for configuring IPSP on the system. For more information on commands that configure additional parameters and options, refer to the *IPSP Configuration Mode Commands* chapter in the *Command Line Interface Reference*.

Use the following example to enable the IPSP on secondary HA:

```
configure
context <ipsp_ctxt_name> [ -noconfirm ]
interface <ipsp_if_name>
pool-share-protocol primary <pri_ha_address> [ mode {active | inactive |
check-config } ]
dead-interval <dur_sec>
end
```

Notes:

- The interface must be configured in the same context as the HA service and must be on the same network as the primary HA's IPSP interface.
- *ipsp_if_name* is the name of the interface on which you want to enable IPSP.
- *dead-interval* is an optional command to configure time to wait before retrying the primary HA for the IP Pool Sharing Protocol.

Enabling IPSP on the Primary HA

The primary HA is the HA that is to be upgraded.



Important

This section provides the minimum instruction set for configuring IPSP on the system. For more information on commands that configure additional parameters and options, refer to the *IPSP Configuration Mode Commands* chapter in the *Command Line Interface Reference*.

Use the following example to enable the IPSP on primary HA:

```
configure
context <ipsp_ctxt_name> [ -noconfirm ]
interface <ipsp_if_name>
pool-share-protocol secondary <sec_ha_address> [ mode {active | inactive |
check-config } ]
dead-interval <dur_sec>
end
```

Notes:

- The interface must be configured in the same context as the HA service and must be on the same network as the secondary HA's IPSP interface.

- `ipsp_if_name` is the name of the interface on which you want to enable IPSP.
- `dead-interval` is an optional command to configure time to wait before retrying the secondary HA for the IP Pool Sharing Protocol.

**Important**

Once this configuration is done, the primary HA begins to hand responsibility for sessions and release IP addresses to the secondary HA. Prior to performing the software upgrade, all IP addresses must be released. When IPSP has released all IP pool addresses from the primary HA an SNMP trap (**starIPSPAllAddrsFree**) is triggered.

Verifying the IPSP Configuration

These instructions are used to verify the IPSP configuration.

Verify that IPSP has released all IP addresses by entering the following command in Exec Mode with in specific context:

```
show ip ipsp
```

The output of this command provides the list of used addresses and released addresses. The system will send the **starIPSPAllAddrsFree** trap once all IP addresses are released. When the value in the *Used Addresses* column reaches 0 for all IP pools listed, then the primary HA sends the SNMP trap and notifies the secondary HA to take over as the primary HA.

Configuring IPSP After the Software Upgrade

If desired, IP pool addresses can be migrated from the original secondary HA back to the original primary HA once the upgrade process is complete.

**Important**

It is important to note that the HA that was originally designated as the secondary is now functioning as the primary HA. Conversely, the HA that was originally designated as the primary is now functioning as the secondary.

In order to migrate the addresses, both HAs and the AAA server must be configured according to the instructions in this section.

This section provides information and instructions for configuring IPSP after the software upgrade.

**Important**

This section provides the minimum instruction set for configuring IPSP on the system. For more information on commands that configure additional parameters and options, refer *IPSP Configuration Mode Commands* chapter in the *Command Line Interface Reference*.

To enable the IP pool sharing after software upgrade:

-
- Step 1** Configure the AAA servers by applying the example configuration in [Configuring the AAA Server for IPSP](#), on page 398.
- Step 2** Configure an interface on the system for use by IPSP according to the instructions found in the Creating and Configuring Ethernet Interfaces and Ports section of *System Administration Guide*.
- Step 3** Enable the IPSP on secondary HA by applying the example configuration in [Enabling IPSP on the Secondary HA](#), on page 399.
- Step 4** Enable the IPSP on primary HA by applying the example configuration in [Enabling IPSP on the Primary HA](#), on page 399.
- Step 5** Verify your ACL configuration by following the steps in the *Verifying the IPSP Configuration*.
- Step 6** Save your configuration to flash memory, an external memory device, and/or a network location using the Exec mode command **save configuration**. For additional information on how to verify and save configuration files, refer to the *System Administration Guide* and the *Command Line Interface Reference*.
-

Disabling IPSP

Once all IP addresses on the primary HA have been released, IPSP must be disabled on both the primary and secondary HAs.



Caution Prior to disabling IPSP, ensure that the primary HA has released all IP addresses to secondary HA.

Follow the instructions in this section to disable IPSP on primary and secondary HA after migration of all IP addresses.



Important This section provides the minimum instruction set for disabling IPSP on the HAs. For more information on commands, refer to the *IPSP Configuration Mode Commands* chapter in the *Command Line Interface Reference*.

Use the following example to enable the IPSP on primary/secondary HA:

```
configure
context <ipsp_ctxt_name> [ -noconfirm ]
interface <ipsp_if_name>
no pool-share-protocol
end
```

Notes:

- The interface must be configured in the same context as the primary/secondary HA service and must be on the same network as the primary/secondary HA's IPSP interface.
- *ipsp_if_name* is the name of the interface on which you want to disable IPSP.
- IPSP must be disabled on both the HAs.



APPENDIX **K**

Intelligent Traffic Control

Before using the procedures in this chapter, it is recommended that you select the configuration example that best meets your service model, and configure the required elements as per that model.

This chapter contains the following topics:

- [Overview, on page 403](#)
- [Licensing, on page 404](#)
- [How it Works, on page 404](#)
- [Configuring Flow-based Traffic Policing, on page 405](#)

Overview

Intelligent Traffic Control (ITC) enables you to configure a set of customizable policy definitions that enforce and manage service level agreements for a subscriber profile, thus enabling you to provide differentiated levels of services for native and roaming subscribers.

In 3GPP2 service ITC uses a local policy look-up table and permits either static EV-DO Rev 0 or dynamic EV-DO Rev A policy configuration.



Important

ITC includes the class-map, policy-map and policy-group commands. Currently ITC does not include an external policy server interface.

ITC provides per-subscriber/per-flow traffic policing to control bandwidth and session quotas. Flow-based traffic policing enables the configuring and enforcing bandwidth limitations on individual subscribers, which can be enforced on a per-flow basis on the downlink and the uplink directions.

Flow-based traffic policies are used to support various policy functions like Quality of Service (QoS), and bandwidth, and admission control. It provides the management facility to allocate network resources based on defined traffic-flow, QoS, and security policies.

ITC and EV-DO Rev A in 3GPP2 Networks



Important

The Ev-Do Rev is a licensed Cisco feature. A separate feature license may be required. Contact your Cisco account representative for detailed information on specific licensing requirements. For information on installing and verifying licenses, refer to the *Managing License Keys* section of the *Software Management Operations* chapter in the *System Administration Guide*.

You can configure your system to support both EV-DO Rev A and ITC. ITC uses flow-based traffic policing to configure and enforce bandwidth limitations per subscriber. Enabling EV-DO Rev A with ITC allows you to control the actual level of bandwidth that is allocated to individual subscriber sessions and the application flows within the sessions.

For more information on EV-DO Rev A, refer to the *Policy-Based Management and EV-DO Rev A* chapter. For setting the DSCP parameters to control ITC functionality, refer to the *Traffic Policy-Map Configuration Mode Commands* chapter in the *Command Line Reference*.

Bandwidth Control and Limiting

Bandwidth control in ITC controls the bandwidth limit, flow action, and charging action for a subscriber, application, and source/destination IP addresses. This is important to help limit bandwidth intensive applications on a network. You can configure ITC to trigger an action to drop, lower-ip-precedence, or allow the flow when the subscriber exceeds the bandwidth usage they have been allotted by their policy.

Licensing

The Intelligent Traffic Control is a licensed Cisco feature. A separate feature license may be required. Contact your Cisco account representative for detailed information on specific licensing requirements. For information on installing and verifying licenses, refer to the *Managing License Keys* section of the *Software Management Operations* chapter in the *System Administration Guide*.

How it Works

ITC enables you to configure traffic policing on a per-subscriber/per-flow basis with the potential to manipulate Differentiated Services Code Points (DSCPs), queue redirection (for example, move traffic to a Best Effort (BE) classification), or drop profile traffic.

In flow-based traffic policies, policy modules interact with the system through a set of well defined entry points, provide access to a stream of system events, and permit the defined policies to implement functions such as access control decisions, QoS enforcement decisions, etc.

Traffic policing can be generally defined as

policy: condition >> action

- **condition:** Specifies the flow-parameters like source-address, destination-address, source-port, destination-port, protocol, etc. for ingress and/or egress packet.

- **action:** Specifies a set of treatments for flow/packet when condition matches. Broadly these actions are based on:
 - Flow Classification: Each flow is classified separately on the basis of source-address, destination-address, source-port, destination-port, protocol, etc. for ingress and/or egress packet. After classification access-control allowed or denied by the system.
 - QoS Processing for individual flow and DSCP marking: Flow-based traffic policing is implemented by each flow separately for the traffic-policing algorithm. Each flow has its own bucket (burst-size) along with committed data rate and peak data rate. A Token Bucket Algorithm (a modified trTCM) [RFC2698] is used to implement this flow-based QoS traffic policing feature.Refer to the *Traffic Policing and Shaping* chapter for more information on Token Bucket Algorithm.

Configuring Flow-based Traffic Policing

Traffic Policing is configured on a per-subscriber basis for either locally configured subscribers on the system or subscriber profiles configured on a remote RADIUS server.

Flow-based traffic policy is configured on the system with the following building blocks:

- Class Maps: The basic building block of a flow-based traffic policing. It is used to control over the packet classification.
- Policy Maps: A more advanced building block for a flow-based traffic policing. It manages admission control based on the Class Maps and the corresponding flow treatment based on QoS traffic-police or QoS DSCP marking.
- Policy Group: This is a set of one or more Policy Maps applied to a subscriber. it also resolves the conflict if a flow matches to multiple policies.

This section provides instructions for configuring traffic policies and assigning to local subscriber profiles on the system.

For information on how to configure subscriber profiles on a remote RADIUS server, refer to the *StarentVSA* and *StarentVSA1* dictionary descriptions in the *AAA and GTP Interface Administration and Reference*.



Important

This section provides the minimum instruction set for configuring flow-based traffic policing on an AGW service. Commands that configure additional properties are provided in the *Command Line Interface Reference*.

These instructions assume that you have already configured the system-level configuration as described in product administration guide.

To configure the flow-based traffic policing on an AGW service:

1. Configure the traffic class maps on the system to support flow-based traffic policing by applying the example configuration in [Configuring Class Maps, on page 406](#).
2. Configure the policy maps with traffic class maps on the system to support flow-based traffic policing by applying the example configuration in [Configuring Policy Maps, on page 407](#).

3. Configure the policy group with policy maps on the system to support flow-based traffic policing by applying the example configuration in [Configuring Policy Groups, on page 407](#).
4. Associate the subscriber profile with policy group to enable flow-based traffic policing for subscriber by applying the example configuration in [Configuring a Subscriber for Flow-based Traffic Policing, on page 408](#).
5. Verify your flow-based traffic policing configuration by following the steps in [Verifying Flow-based Traffic Policing Configuration, on page 408](#).
6. Save your configuration to flash memory, an external memory device, and/or a network location using the Exec mode command **save configuration**. For additional information on how to verify and save configuration files, refer to the *System Administration Guide* and the *Command Line Interface Reference*.

Configuring Class Maps

This section describes how to configure Class Maps on the system to support Flow-based Traffic Policing.



Important

In this mode classification match rules added sequentially with **match** command to form a Class-Map. To change and/or delete or re-add a particular rule user must delete specific Class-Map and re-define it.

configure

```

context <vpn_context_name> [ -noconfirm ]
  class-map name <class_name> [ match-all | match-any ]
    match src-ip-address <src_ip_address> [ <subnet_mask> ]
    match dst-ip-address <dst_ip_address> [ <subnet_mask> ]
    match source-port-range <initial_port_number> [ to
<last_port_number> ]
    match dst-port-range <initial_port_number> [ to <last_port_number>
]
    match protocol [ tcp | udp | gre | ip-in-ip ]
    match ip-tos <service_value>
    match ipsec-spi <index_value>
    match packet-size [ gt | lt ] <size>
  end

```

Notes:

- *<vpn_context_name>* is the name of the destination context in which you want to configure the flow-based traffic policing.
- *<class_name>* is the name of the traffic class to map with the flow for the flow-based traffic policing. A maximum of 32 class-maps can be configured in one context.
- For description and variable values of these commands and keywords, refer to the *Class-Map Configuration Mode Commands* chapter of the *Command Line Interface Reference*.

Configuring Policy Maps

This section provides information and instructions for configuring the policy maps on the system to support flow-based traffic policing.

configure

```

context <vpn_context_name>
  policy-map name <policy_name>
    class <class_name>
      type { static | dynamic }
      access-control { allow | discard }
      qos traffic-police committed <bps> peak <bps> burst-size
<byte> exceed-action { drop | lower-ip-precedence | allow } violate-action
  { drop | lower-ip-precedence | allow }
      qos encaps-header dscp-marking [ copy-from-user-datagram
| <dscp_code> ]
    end

```

Notes:

- <vpn_context_name> is the name of the destination context in which is configured during Class-Map configuration for flow-based traffic policing.
- <policy_name> is the name of the traffic policy map you want to configure for the flow-based traffic policing. A maximum of 32 policy maps can be configured in one context.
- <class_name> is the name of the traffic class to map that you configured in *Configuring Class Maps* section for the flow-based traffic policing.
- For description and variable values of these commands and keywords, refer to the *Traffic Policy-Map Configuration Mode Commands* chapter of the *Command Line Interface Reference*.

Configuring Policy Groups

This section provides information and instructions for configuring the policy group in a context to support flow-based traffic policing.

configure

```

context <vpn_context_name>
  policy-group name <policy_group>
    policy <policy_map_name> precedence <value>
  end

```

Notes:

- <vpn_context_name> is the name of the destination context which is configured during Class-Map configuration for flow-based traffic policing.
- <policy_group> is name of the traffic policy group of policy maps you want to configure for the flow-based traffic policing. A maximum of 32 policy groups can be configured in one context.
- <policy_map_name> is name of the traffic policy you configured in *Configuring Policy Maps* section for the flow-based traffic policing. A maximum of 16 Policy Maps can be assigned in a Policy Group.

- For description and variable values of these commands and keywords, refer to the *Traffic Policy-Map Configuration Mode Commands* chapter of the *Command Line Interface Reference*.

Configuring a Subscriber for Flow-based Traffic Policing

This section provides information and instructions for configuring the subscriber for Flow-based Traffic Policing.

```
configure
  context <vpn_context_name>
    subscriber name <user_name>
      policy-group <policy_group> direction [ in | out ]
    end
```

Notes:

- <vpn_context_name> is the name of the destination context configured during Class-Map configuration for flow-based traffic policing.
- <user_name> is the name of the subscriber profile you want to configure for the flow-based traffic policing.
- <policy_group> is name of the traffic policy group you configured in *Configuring Policy Groups* section for the flow-based traffic policing. A maximum of 16 Policy groups can be assigned to a subscriber profile.
- For description and variable values of these commands and keywords, refer to the *Traffic Policy-Group Configuration Mode Commands* chapter of the *Command Line Interface Reference*.

Verifying Flow-based Traffic Policing Configuration

Verify that your flow-based traffic policing is configured properly by entering the following command in Exec Mode:
show subscribers access-flows full

The output of this command displays flow-based information for a subscriber session.



APPENDIX L

L2TP Access Concentrator

This chapter describes the Layer 2 Tunneling Protocol (L2TP) Access Concentrator (LAC) functionality support on Cisco® ASR 5500 chassis and explains how it is configured.

The product Administration Guides provide examples and procedures for configuration of basic services on the system. It is recommended that you select the configuration example that best meets your service model, and configure the required elements for that model, as described in the respective product Administration Guide, before using the procedures in this chapter.



Important

The L2TP Access Concentrator is a licensed Cisco feature. A separate feature license may be required. Contact your Cisco account representative for detailed information on specific licensing requirements. For information on installing and verifying licenses, refer to the *Managing License Keys* section of the *Software Management Operations* chapter in the *System Administration Guide*.

When enabled through the session license and feature use key, the system supports L2TP for encapsulation of data packets between it and one or more L2TP Network Server (LNS) nodes. In the system, this optional packet encapsulation, or tunneling, is performed by configuring L2TP Access Concentrator (LAC) services within contexts.



Important

While establishing the L2TP session from LAC to LNS, the PPP connection for the user is established. The server uses CHAP authentication protocol to authenticate the connection. While calculating the CHAP response for the CHAP challenge received by the server, the server does not consider the CHAP password.



Important

The LAC service uses UDP ports 13660 through 13668 as the source port for sending packets to the LNS.

This chapter contains the following topics:

- [Applicable Products and Relevant Sections, on page 410](#)
- [Supported LAC Service Configurations for PDSN Simple IP, on page 411](#)
- [Supported LAC Service Configurations for the GGSN and P-GW, on page 416](#)
- [Supported LAC Service Configuration for Mobile IP, on page 422](#)
- [Configuring Subscriber Profiles for L2TP Support, on page 425](#)
- [Feature Description, on page 429](#)

- [Configuring LAC Services, on page 429](#)
- [Modifying PDSN Services for L2TP Support, on page 431](#)
- [Modifying APN Templates to Support L2TP, on page 433](#)

Applicable Products and Relevant Sections

The LAC feature is supported for various products. The following table indicates the products on which the feature is supported and the relevant sections within the chapter that pertain to that product.

Applicable Product(s)	Refer to Sections
PDSN/FA/HA	<ul style="list-style-type: none"> • <i>Supported LAC Service Configurations for PDSN Simple IP</i> • <i>Supported LAC Service Configuration for Mobile IP</i> • <i>Configuring Subscriber Profiles for L2TP Support</i> <ul style="list-style-type: none"> • <i>RADIUS and Subscriber Profile Attributes Used</i> • <i>Configuring Local Subscriber Profiles for L2TP Support</i> • <i>Tunneling All Subscribers in a Specific Context Without Using RADIUS Attributes</i> • <i>Configuring LAC Services</i> • <i>Modifying PDSN Services for L2TP Support</i>
GGSN/SGSN/FA/P-GW	<ul style="list-style-type: none"> • <i>Supported LAC Service Configurations for the GGSN</i> • <i>Supported LAC Service Configuration for Mobile IP</i> • <i>Configuring Subscriber Profiles for L2TP Support</i> <ul style="list-style-type: none"> • <i>RADIUS and Subscriber Profile Attributes Used</i> • <i>Configuring Local Subscriber Profiles for L2TP Support</i> • <i>Enabling Multicast Services over L2TP</i> • <i>Configuring LAC Services</i> • <i>Modifying APN Templates to Support L2TP</i>

Applicable Product(s)	Refer to Sections
ASN GW	<ul style="list-style-type: none"> • <i>Supported LAC Service Configuration for Mobile IP</i> • <i>Configuring Subscriber Profiles for L2TP Support</i> <ul style="list-style-type: none"> • <i>RADIUS and Subscriber Profile Attributes Used</i> • <i>Configuring Local Subscriber Profiles for L2TP Support</i> • <i>Tunneling All Subscribers in a Specific Context Without Using RADIUS Attributes</i> • <i>Configuring LAC Services</i>

Supported LAC Service Configurations for PDSN Simple IP

LAC services can be applied to incoming PPP sessions using one of the following methods:

- **Attribute-based tunneling:** This method is used to encapsulate PPP packets for only specific users, identified during authentication. In this method, the LAC service parameters and allowed LNS nodes that may be communicated with are controlled by the user profile for the particular subscriber. The user profile can be configured locally on the system or remotely on a RADIUS server.
- **PDSN Service-based compulsory tunneling:** This method of tunneling is used to encapsulate all incoming PPP traffic from the R-P interface coming into a PDSN service, and tunnel it to an LNS peer for authentication. It should be noted that this method does not consider subscriber configurations, since all authentication is performed by the peer LNS.

Each LAC service is bound to a single system interface configured within the same system context. It is recommended that this context be a destination context as displayed in the following figure.

Figure 38: LAC Service Configuration for SIP

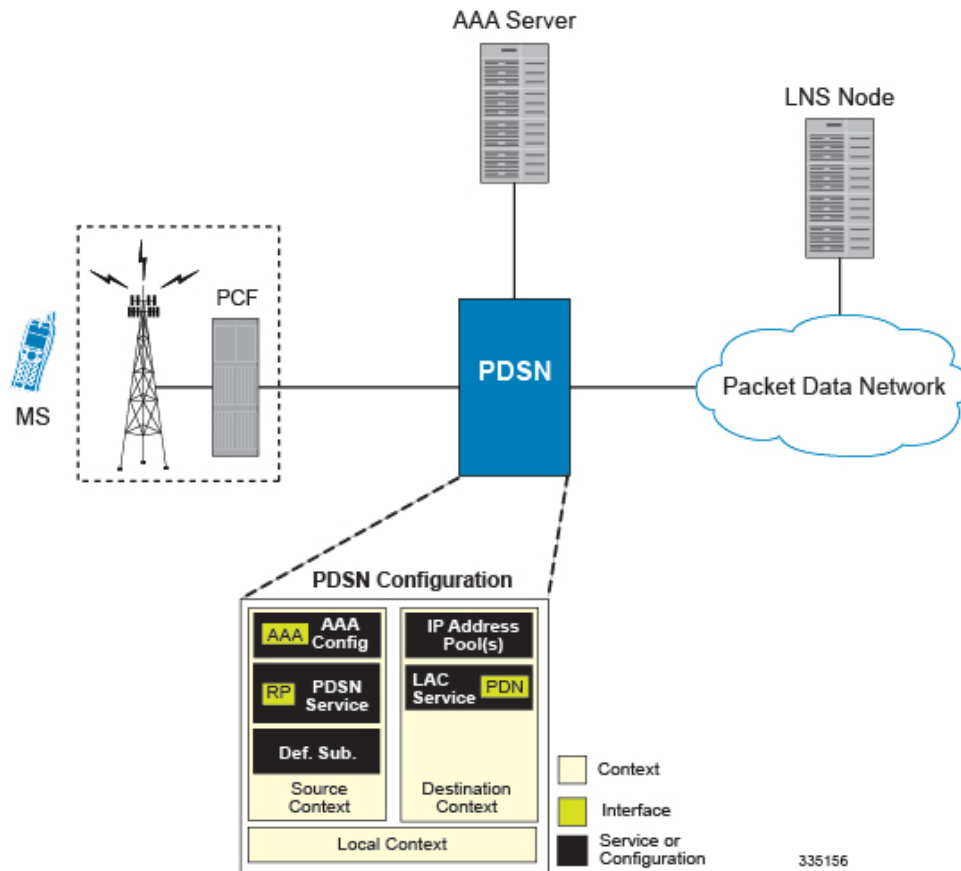

Attribute-based Tunneling

This section describes the working of attribute-based tunneling and its configuration.

How The Attribute-based L2TP Configuration Works

The following figure and the text that follows describe how Attribute-based tunneling is performed using the system.

Figure 39: Attribute-based L2TP Session Processing for SIP

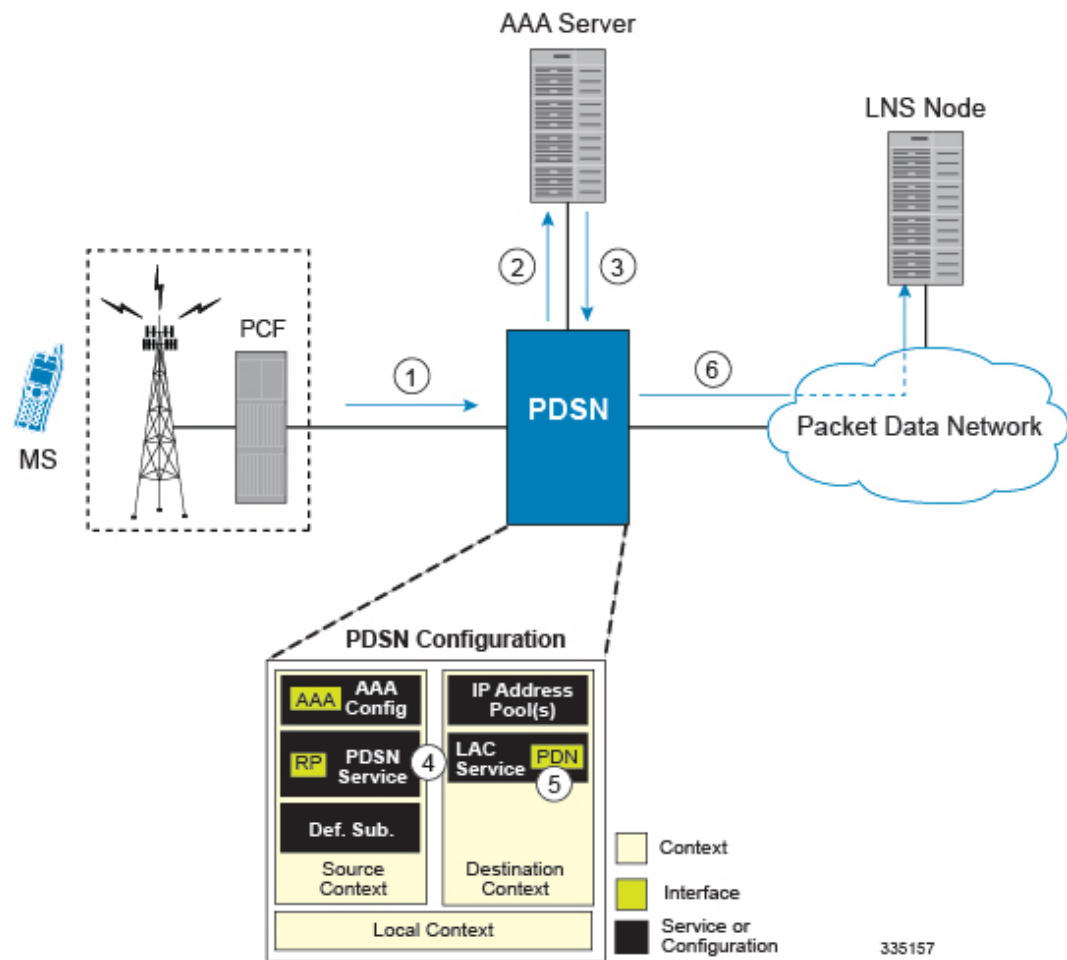

1. A subscriber session from the PCF is received by the PDSN service over the R-P interface.
2. The PDSN service attempts to authenticate the subscriber. The subscriber could be configured either locally or remotely on a RADIUS server. Figure above shows subscriber authentication using a RADIUS AAA server.
3. The RADIUS server returns an Access-Accept message, which includes attributes indicating that session data is to be tunneled using L2TP, and the name and location of the LAC service to use. An attribute could also be provided indicating the LNS peer to connect to.
4. The PDSN service receives the information and then forwards the packets to the LAC service, configured within the Destination context.
5. The LAC service, upon receiving the packets, encapsulates the information and forwards it to the appropriate PDN interface for delivery to the LNS.
6. The encapsulated packets are sent to the peer LNS through the packet data network where they will be un-encapsulated.

Configuring Attribute-based L2TP Support for PDSN Simple IP

This section provides a list of the steps required to configure attribute-based L2TP support for use with PDSN Simple IP applications. Each step listed refers to a different section containing the specific instructions for completing the required procedure.



Important These instructions assume that the system was previously configured to support subscriber data sessions as a PDSN.

-
- Step 1** Configure the subscriber profiles according to the information and instructions located in the *Configuring Subscriber Profiles for L2TP Support* section of this chapter.
- Step 2** Configure one or more LAC services according to the information and instructions located in the *Configuring LAC Services* section of this chapter.
- Step 3** Configure the PDSN service(s) with the tunnel context location according to the instructions located in the *Modifying PDSN Services for L2TP Support* section of this chapter.
- Step 4** Save your configuration to flash memory, an external memory device, and/or a network location using the Exec mode command **save configuration**. For additional information on how to verify and save configuration files, refer to the *System Administration Guide* and the *Command Line Interface Reference*.
-

PDSN Service-based Compulsory Tunneling

This section describes the working of service-based compulsory tunneling and its configuration.

How PDSN Service-based Compulsory Tunneling Works

PDSN Service-based compulsory tunneling enables wireless operators to send all PPP traffic to remote LNS peers over an L2TP tunnel for authentication. This means that no PPP authentication is performed by the system.

Accounting start and interim accounting records are still sent to the local RADIUS server configured in the system's AAA Service configuration. When the L2TP session setup is complete, the system starts its call counters and signals the RADIUS server to begin accounting. The subscriber name for accounting records is based on the NAI-constructed name created for each session.

PDSN service-based compulsory tunneling requires the modification of one or more PDSN services and the configuration of one or more LAC services.

The following figure and the text that follows describe how PDSN service-based compulsory tunneling is performed using the system.

Figure 40: PDSN Service-based Compulsory Tunneling Session Processing

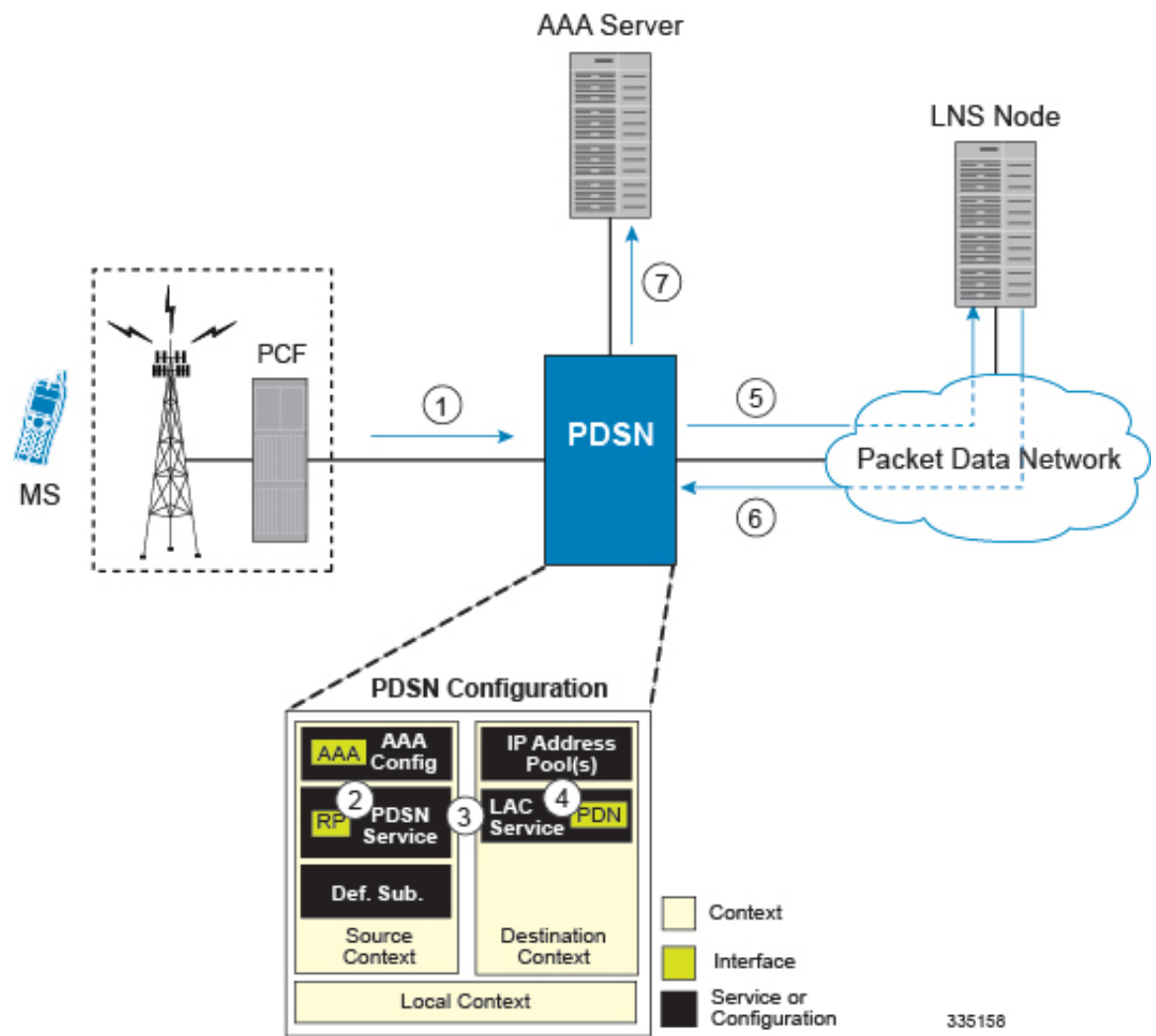

1. A subscriber session from the PCF is received by the PDSN service over the R-P interface.
2. The PDSN service detects its **tunnel-type** parameter is configured to L2TP and its **tunnel-context** parameter is configured to the Destination context.
3. The PDSN forwards all packets for the session to a LAC service configured in the Destination context. If multiple LAC services are configured, session traffic will be routed to each using a round-robin algorithm.
4. The LAC service initiates an L2TP tunnel to one of the LNS peers listed as part of its configuration.
5. Session packets are passed to the LNS over a packet data network for authentication.
6. The LNS authenticates the session and returns an Access-Accept to the PDSN.
7. The PDSN service initiates accounting for the session using a constructed NAI. Session data traffic is passed over the L2TP tunnel established in step 4.

Configuring L2TP Compulsory Tunneling Support for PDSN Simple IP

This section provides a list of the steps required to configure L2TP compulsory tunneling support for use with PDSN Simple IP applications. Each step listed refers to a different section containing the specific instructions for completing the required procedure.



Important These instructions assume that the system was previously configured to support subscriber data sessions as a PDSN.

-
- Step 1** Configure one or more LAC services according to the information and instructions located in the *Configuring LAC Services* section of this chapter.
- Step 2** Configure the PDSN service(s) according to the instructions located in the *Modifying PDSN Services for L2TP Support* section of this chapter.
- Step 3** Save your configuration to flash memory, an external memory device, and/or a network location using the Exec mode command **save configuration**. For additional information on how to verify and save configuration files, refer to the *System Administration Guide* and the *Command Line Interface Reference*.
-

Supported LAC Service Configurations for the GGSN and P-GW

As mentioned previously, L2TP is supported through the configuration of LAC services on the system. Each LAC service is bound to a single system interface configured within the same system destination context as displayed in following figure.

Figure 41: GGSN LAC Service Configuration

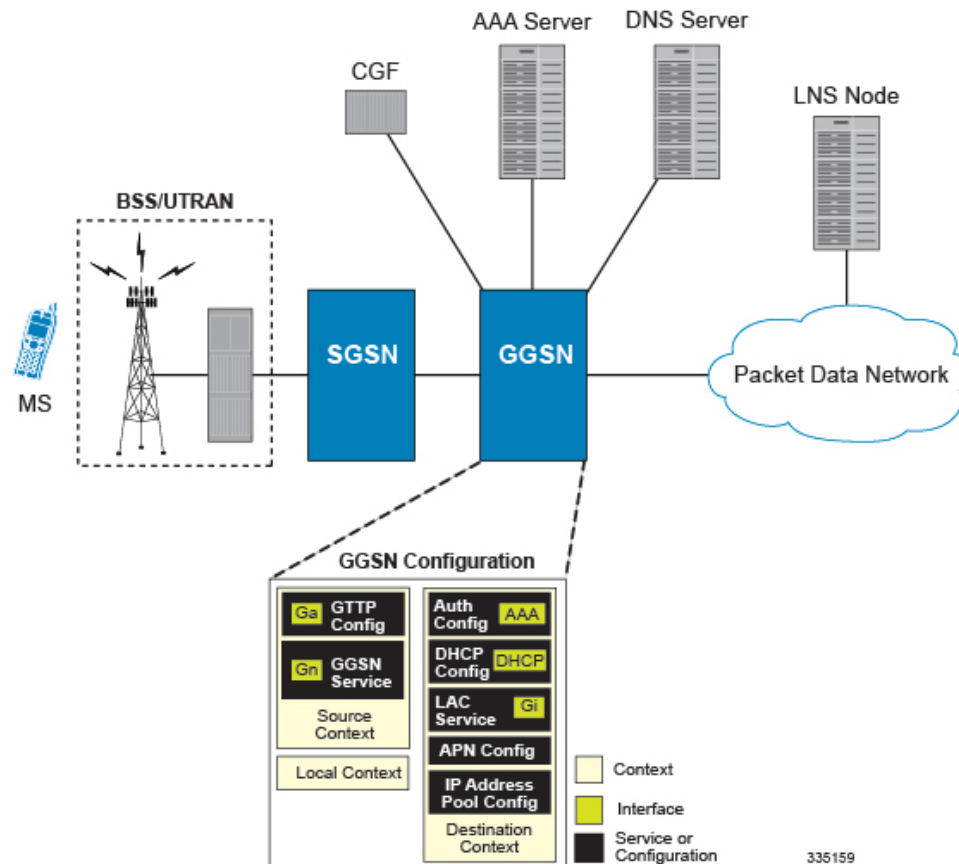

LAC services are applied to incoming subscriber PDP contexts based on the configuration of attributes either in the GGSN's Access Point Name (APN) templates or in the subscriber's profile. Subscriber profiles can be configured locally on the system or remotely on a RADIUS server.

LAC service also supports domain-based L2TP tunneling with LNS. This method is used to create multiple tunnels between LAC and LNS on the basis of values received in "Tunnel-Client-Auth-ID" or "Tunnel-Server-Auth-ID" attribute received from AAA Server in Access-Accept as a key for tunnel selection and creation. When the LAC needs to establish a new L2TP session, it first checks if there is any existing L2TP tunnel with the peer LNS based on the value of key "Tunnel-Client-Auth-ID" or "Tunnel-Server-Auth-ID" attribute. If no such tunnel exists for the key, it will create a new Tunnel with the LNS.

If LAC service needs to establish a new tunnel for new L2TP session with LNS and the tunnel create request fails because maximum tunnel creation limit is reached, LAC will try other LNS addresses received from AAA server in Access-Accept message. If all available peer-LNS are exhausted, LAC service will reject the call

L2TP tunnel parameters are configured within the APN template and are applied to all subscribers accessing the APN. However, L2TP operation will differ depending on the subscriber's PDP context type as described below:

- **Transparent IP:** The APN template's L2TP parameter settings will be applied to the session.
- **Non-transparent IP:** Since authentication is required, L2TP parameter attributes in the subscriber profile (if configured) will take precedence over the settings in the APN template.

- **PPP:** The APN template's L2TP parameter settings will be applied and all of the subscriber's PPP packets will be forwarded to the specified LNS.

More detailed information is located in the sections that follow.

Transparent IP PDP Context Processing with L2TP Support

The following figure and the text that follows describe how transparent IP PDP contexts are processed when L2TP tunneling is enabled.

Figure 42: Transparent IP PDP Context Call Processing with L2TP Tunneling

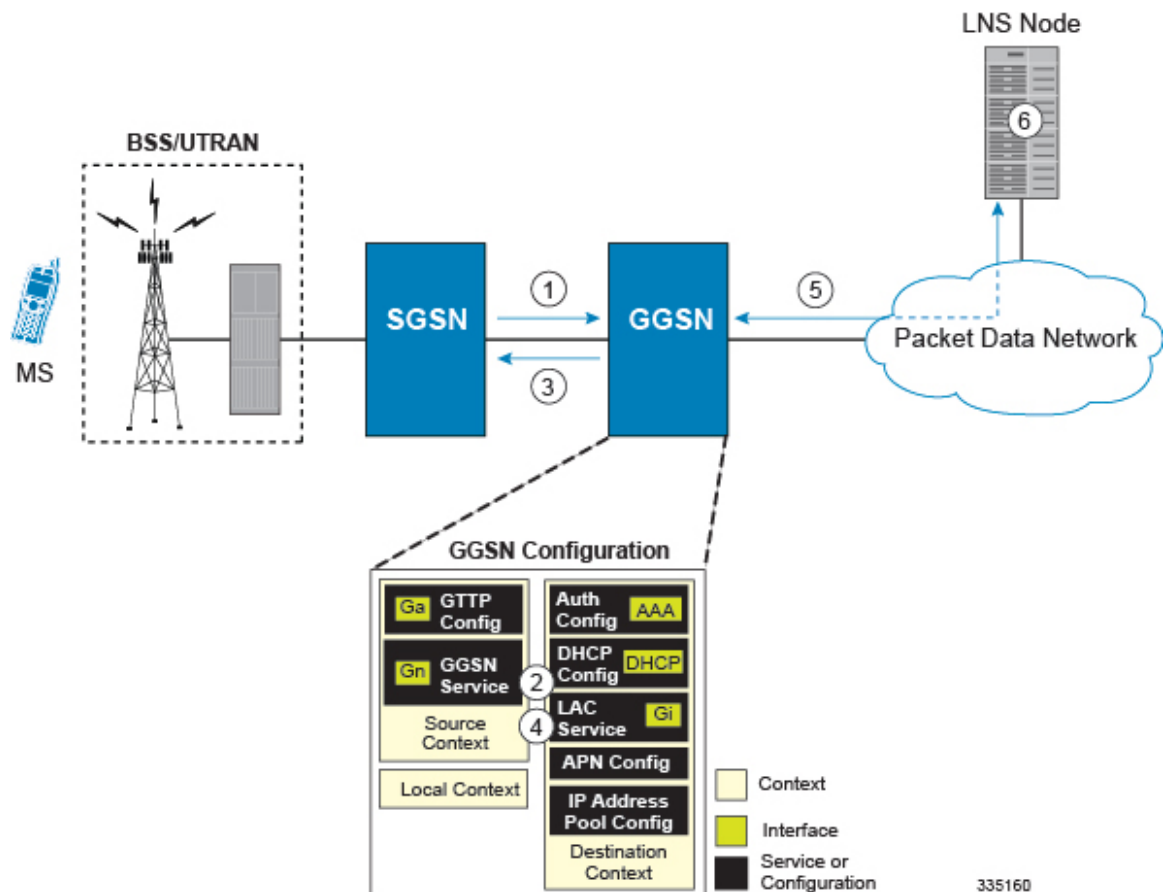

1. A Create PDP Context Request message for a subscriber session is sent from the SGSN to the GGSN service over the Gn interface. The message contains information such as the PDP Type, APN, and charging characteristics.
2. The GGSN determines whether or not it is configured with an APN identical to the one specified in the message. If so, it determines how to process the session based on the configuration of the APN.

The APN configuration indicates such things as the IP address of the LNS, the system destination context in which a LAC service is configured, and the outbound username and password that will be used by the LNS to authenticate incoming sessions. If no outbound information is configured, the subscriber's International Mobile Subscriber Identity (IMSI) is used as the username at the peer LNS.

1. The GGSN returns an affirmative Create PDP Context Response to the SGSN over the Gn interface.
2. The GGSN passes data received from the MS to a LAC service.
3. The LAC service encapsulates the IP packets and forwards it to the appropriate Gi interface for delivery to the LNS.
4. The LNS un-encapsulates the packets and processes them as needed. The processing includes IP address allocation.

Non-transparent IP PDP Context Processing with L2TP Support

The following figure and the text that follows describe how non-transparent IP PDP contexts are processed when L2TP tunneling is enabled.

Figure 43: Non-transparent IP PDP Context Call Processing with L2TP Tunneling

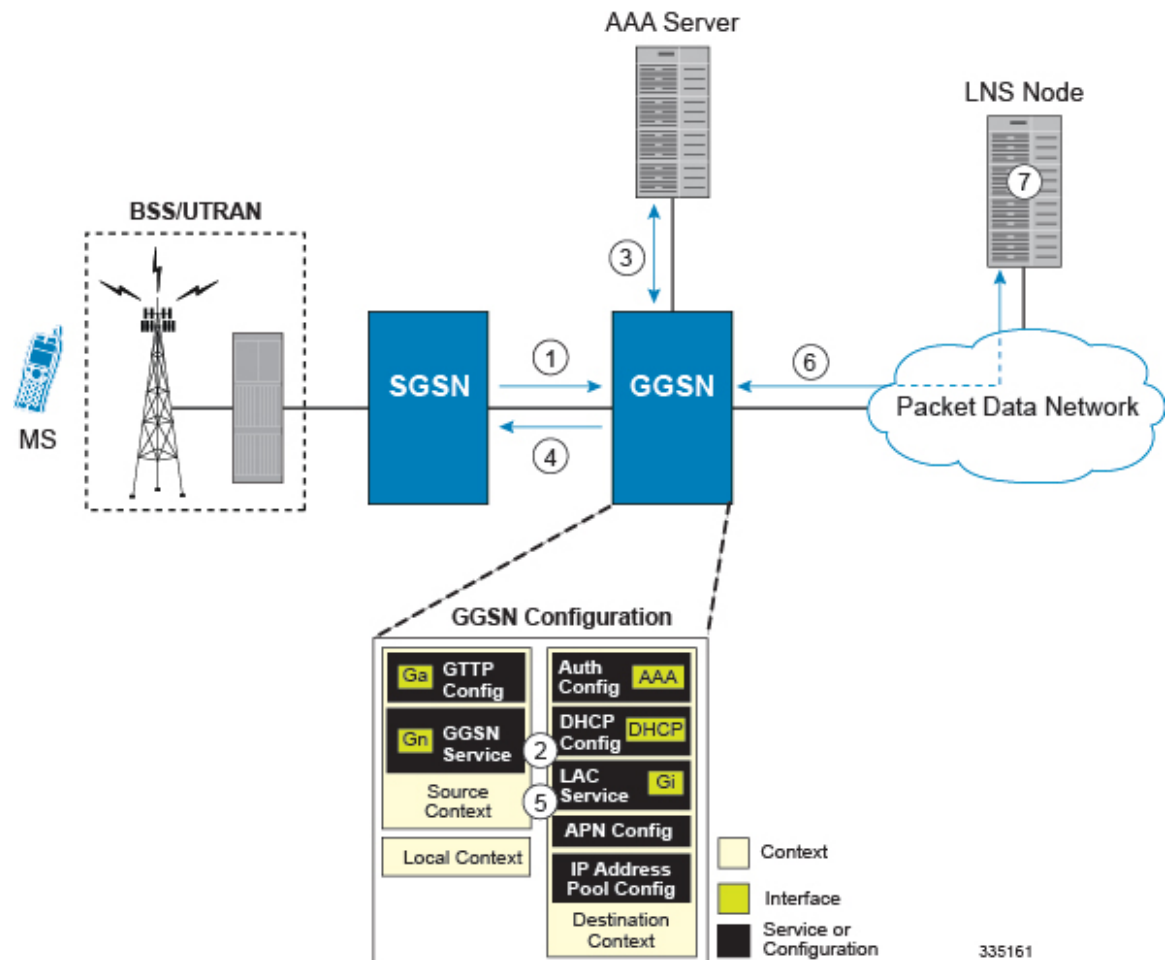

1. A Create PDP Context Request message for a subscriber session is sent from the SGSN to the GGSN service over the Gn interface. The message contains information such as the PDP Type, APN, and charging characteristics.

2. The GGSN determines whether or not it is configured with an APN identical to the one specified in the message. If so, it determines how to process the session based on the configuration of the APN.

The APN configuration indicates such things as the IP address of the LNS, the system destination context in which a LAC service is configured, and the outbound username and password that will be used by the LNS to authenticate incoming sessions. If no outbound information is configured, the subscriber's username is sent to the peer LNS.

3. The GGSN service authenticates the subscriber. The subscriber could be configured either locally or remotely on a RADIUS server. Figure above shows subscriber authentication using a RADIUS AAA server.

As part of the authentication, the RADIUS server returns an Access-Accept message.

The message may include attributes indicating that session data is to be tunneled using L2TP, and the name and location of the LAC service to use. An attribute could also be provided indicating the LNS peer to connect to.

If these attributes are supplied, they take precedence over those specified in the APN template.

4. The GGSN returns an affirmative Create PDP Context Response to the SGSN over the Gn interface.
5. The GGSN passes data received from the MS to a LAC service.
6. The LAC service encapsulates the IP packets and forwards it to the appropriate Gi interface for delivery to the LNS.
7. The LNS un-encapsulates the packets and processes them as needed. The processing includes authentication and IP address allocation.

PPP PDP Context Processing with L2TP Support

The following figure and the text that follows describe how non-transparent IP PDP contexts are processed when L2TP tunneling is enabled.

Figure 44: PPP PDP Context Call Processing with L2TP Tunneling

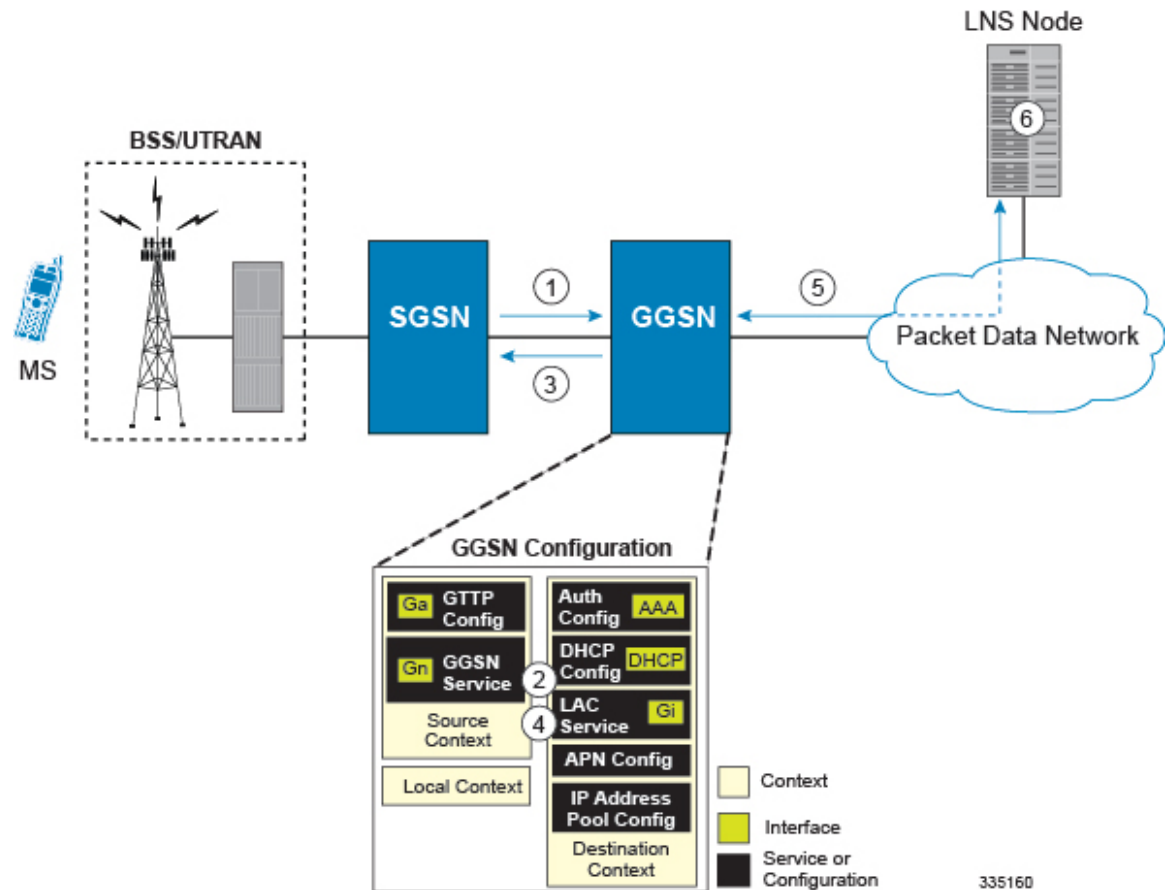

1. A Create PDP Context Request message for a subscriber session is sent from the SGSN to the GGSN service over the Gn interface. The message contains information such as the PDP Type, APN, and charging characteristics.
2. The GGSN determines whether or not it is configured with an APN identical to the one specified in the message. If so, it determines how to process the session based on the configuration of the APN.

The APN configuration indicates such things as the IP address of the LNS, the system destination context in which a LAC service is configured.

Note that L2TP support could also be configured in the subscriber's profile. If the APN is not configured for L2TP tunneling, the system will attempt to authenticate the subscriber. The tunneling parameters in the subscriber's profile would then be used to determine the peer LNS.

3. The GGSN returns an affirmative Create PDP Context Response to the SGSN over the Gn interface.
4. The GGSN passes the PPP packets received from the MS to a LAC service.
5. The LAC service encapsulates the PPP packets and forwards it to the appropriate Gi interface for delivery to the LNS.
6. The LNS un-encapsulates the packets and processes them as needed. The processing includes PPP termination, authentication (using the username/password provided by the subscriber), and IP address allocation.

Configuring the GGSN or P-GW to Support L2TP

This section provides a list of the steps required to configure the GGSN or P-GW to support L2TP. Each step listed refers to a different section containing the specific instructions for completing the required procedure.



Important These instructions assume that the system was previously configured to support subscriber data sessions as a GGSN or P-GW.

Step 1 Configure the APN template to support L2TP tunneling according to the information and instructions located in the *Modifying APN Templates to Support L2TP* section of this chapter.

Important L2TP tunneling can be configured within individual subscriber profiles as opposed/or in addition to configuring support with an APN template. Subscriber profile configuration is described in the *Configuring Subscriber Profiles for L2TP Support* section of this chapter.

Step 2 Configure one or more LAC services according to the information and instructions located in the *Configuring LAC Services* section of this chapter.

Step 3 Save your configuration to flash memory, an external memory device, and/or a network location using the Exec mode command **save configuration**. For additional information on how to verify and save configuration files, refer to the *System Administration Guide* and the *Command Line Interface Reference*.

Supported LAC Service Configuration for Mobile IP

LAC services can be applied to incoming MIP sessions using attribute-based tunneling. Attribute-based tunneling is used to encapsulate PPP packets for specific users, identified during authentication. In this method, the LAC service parameters and allowed LNS nodes that may be communicated with are controlled by the user profile for the particular subscriber. The user profile can be configured locally on the system or remotely on a RADIUS server.

Each LAC service is bound to a single system interface within the same system context. It is recommended that this context be a destination context as displayed in figure below.

Figure 45: LAC Service Configuration for MIP

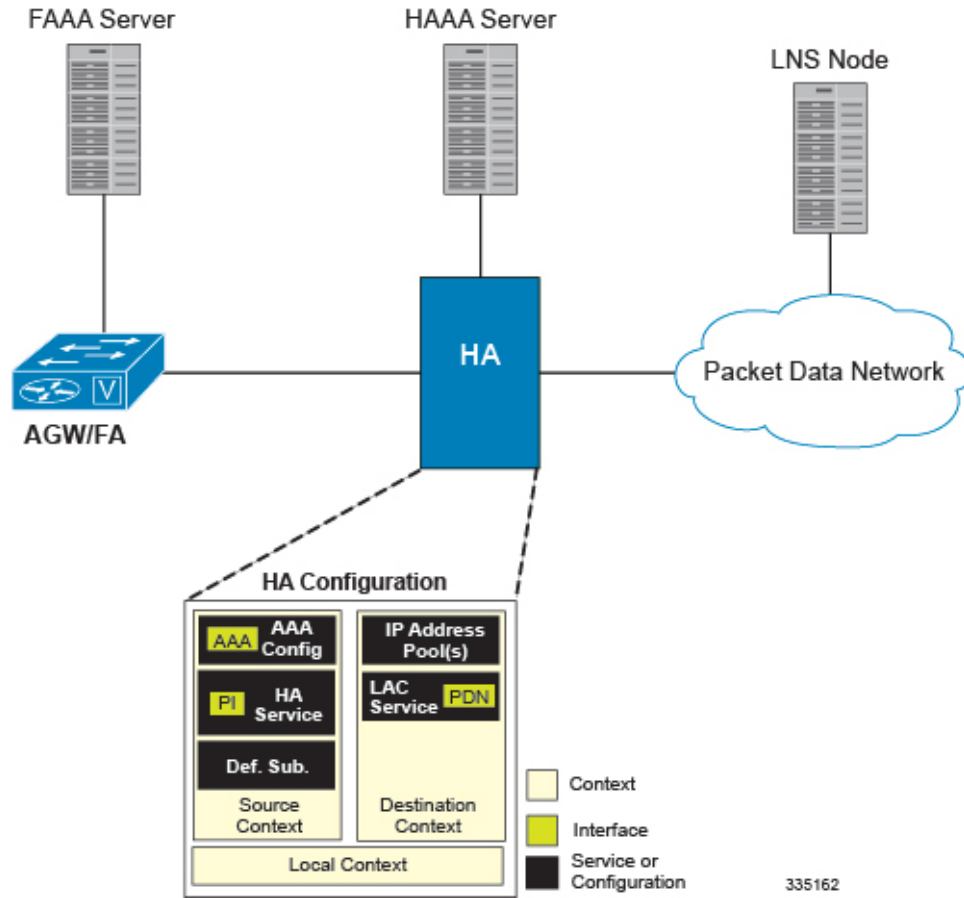

How The Attribute-based L2TP Configuration for MIP Works

The following figure and the text that follows describe how Attribute-based tunneling for MIP is performed using the system.

Figure 46: Attribute-based L2TP Session Processing for MIP

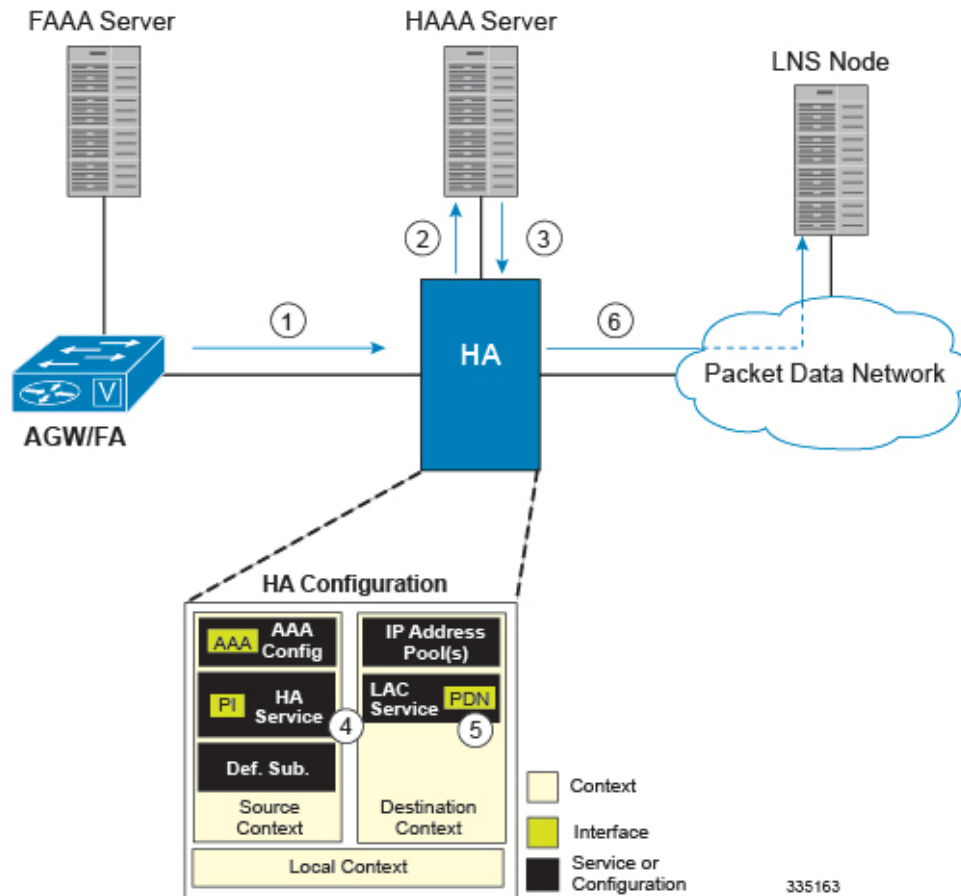

1. A subscriber session from the FA is received by the HA service over the Pi interface.
2. The HA service attempts to authenticate the subscriber. The subscriber could be configured either locally or remotely on a RADIUS server. Figure above shows subscriber authentication using a RADIUS AAA server.
3. The RADIUS server returns an Access-Accept message, which includes attributes indicating that session data is to be tunneled using L2TP, and the name and location of the LAC service to use. An attribute could also be provided indicating the LNS peer to connect to.
4. The HA service receives the information and then forwards the packets to the LAC service, configured within the Destination context.
5. The LAC service, upon receiving the packets, encapsulates the information and forwards it to the appropriate PDN interface for delivery to the LNS.
6. The encapsulated packets are sent to the peer LNS through the packet data network where they will be un-encapsulated.

Configuring Attribute-based L2TP Support for HA Mobile IP

This section provides a list of the steps required to configure attribute-based L2TP support for use with HA Mobile IP applications. Each step listed refers to a different section containing the specific instructions for completing the required procedure.



Important These instructions assume that the system was previously configured to support subscriber data sessions as an HA.

- Step 1** Configure the subscriber profiles according to the information and instructions located in the *Configuring Subscriber Profiles for L2TP Support* section of this chapter.
- Step 2** Configure one or more LAC services according to the information and instructions located in the *Configuring LAC Services* section of this chapter.
- Step 3** Save your configuration to flash memory, an external memory device, and/or a network location using the Exec mode command **save configuration**. For additional information on how to verify and save configuration files, refer to the *System Administration Guide* and the *Command Line Interface Reference*.

Configuring Subscriber Profiles for L2TP Support

This section provides information and instructions on the following procedures:

- [RADIUS and Subscriber Profile Attributes Used, on page 425](#)
- [Configuring Local Subscriber Profiles for L2TP Support, on page 427](#)
- [Configuring Local Subscriber, on page 428](#)
- [Verifying the L2TP Configuration, on page 428](#)



Important Since the instructions for configuring subscribers differ between RADIUS server applications, this section only provides the individual attributes that can be added to the subscriber profile. Refer to the documentation that shipped with your RADIUS server for instructions on configuring subscribers.

RADIUS and Subscriber Profile Attributes Used

Attribute-based L2TP tunneling is supported through the use of attributes configured in subscriber profiles stored either locally on the system or remotely on a RADIUS server. The following table describes the attributes used in support of LAC services. These attributes are contained in the standard and VSA dictionaries.

Table 44: Subscriber Attributes for L2TP Support

RADIUS Attribute	Local Subscriber Attribute	Description	Variable
Tunnel-Type	tunnel l2tp	Specifies the type of tunnel to be used for the subscriber session	L2TP
Tunnel-Server-Endpoint	tunnel l2tp peer-address	Specifies the IP address of the peer LNS to connect tunnel to.	IPv4 address in dotted-decimal format, enclosed in quotation marks

RADIUS Attribute	Local Subscriber Attribute	Description	Variable
Tunnel-Password	tunnel l2tp secret	Specifies the shared secret between the LAC and LNS.	Alpha and or numeric string from 1 to 63 characters, enclosed in quotation marks
Tunnel-Private- Group-ID	tunnel l2tp tunnel-context	Specifies the name of the destination context configured on the system in which the LAC service(s) to be used are located. Important If the LAC service and egress interface are configured in the same context as the core service or HA service, this attribute is not needed.	Alpha and or numeric string from 1 to 63 characters, enclosed in quotation marks
Tunnel-Preference	tunnel l2tp preference	Configures the priority of each peer LNS when multiple LNS nodes are configured. Important This attribute is only used when the loadbalance-tunnel-peers parameter or SN-Tunnel-Load-Balancing attribute configured to prioritized.	Integer from 1 to 65535

RADIUS Attribute	Local Subscriber Attribute	Description	Variable
SN-Tunnel-Load-Balancing	loadbalance-tunnel- peer	A vendor-specific attribute (VSA) used to provides a selection algorithm defining how an LNS node is selected by the RADIUS server when multiple LNS peers are configured within the subscriber profile.	<ul style="list-style-type: none"> • Random - Random LNS selection order, the Tunnel-Preference attribute is not used in determining which LNS to select. • Balanced - LNS selection is sequential balancing the load across all configured LNS nodes, the Tunnel-Preference attribute is not used in determining which LNS to select. • Prioritized - LNS selection is made based on the priority assigned in the Tunnel-Preference attribute.
Client-Endpoint	local-address	<p>Specifies the IP address of a specific LAC service configured on the system that to use to facilitate the subscriber's L2TP session.</p> <p>This attribute is used when multiple LAC services are configured.</p>	IPv4 address in dotted decimal notation. (xxx.xxx.xxx.xxx)

RADIUS Tagging Support

The system supports RADIUS attribute tagging for tunnel attributes. These "tags" organize together multiple attributes into different groups when multiple LNS nodes are defined in the user profile. Tagging is useful to ensure that the system groups all the attributes used for a specific server. If attribute tagging is not supported by your specific RADIUS server, the system implicitly organizes the attributes in the order that they are listed in the access accept packet.

Configuring Local Subscriber Profiles for L2TP Support

This section provides information and instructions for configuring local subscriber profiles on the system to support L2TP.



Important The configuration of RADIUS-based subscriber profiles is not discussed in this document. Please refer to the documentation supplied with your RADIUS server for further information.



Important This section provides the minimum instruction set for configuring local subscriber profile for L2TP support on the system. For more information on commands that configure additional parameters and options, refer to the *LAC Service Configuration Mode Commands* chapter in the *Command Line Interface Reference*.

To configure the system to provide L2TP support to subscribers:

- Step 1** Configure the "Local" subscriber with L2TP tunnel parameters and the load balancing parameters with action by applying the example configuration in the *Configuring Local Subscriber* section.
- Step 2** Verify your L2TP configuration by following the steps in the *Verifying the L2TP Configuration* section.
- Step 3** Save your configuration to flash memory, an external memory device, and/or a network location using the Exec mode command **save configuration**. For additional information on how to verify and save configuration files, refer to the *System Administration Guide* and the *Command Line Interface Reference*.
-

Configuring Local Subscriber

Use the following example to configure the Local subscriber with L2TP tunnel parameters. Optionally you can configure load balancing between multiple LNS servers:

```
configure
  context <ctxt_name> [-noconfirm]
    subscriber name <subs_name>
      tunnel l2tp peer-address <lns_ip_address> [ preference <integer> | [
encrypted ] secret <secret_string> | tunnel-context <context_name> | local-address
<local_ip_address> }
      load-balancing { random | balanced | prioritized }
    end
```

Notes:

- <ctxt_name> is the system context in which you wish to configure the subscriber profile.
- <lns_ip_address> is the IP address of LNS server node and <local_ip_address> is the IP address of system which is bound to LAC service.

Verifying the L2TP Configuration

These instructions are used to verify the L2TP configuration.

Verify that your L2TP configurations were configured properly by entering the following command in Exec Mode in specific context:

```
show subscriber configuration username user_name
```

The output of this command is a concise listing of subscriber parameter settings as configured.

Tunneling All Subscribers in a Specific Context Without Using RADIUS Attributes

As with other services supported by the system, values for subscriber profile attributes not returned as part of a RADIUS Access-Accept message can be obtained using the locally configured profile for the subscriber named default. The subscriber profile for default must be configured in the AAA context (i.e. the context in which AAA functionality is configured).

As a time saving feature, L2TP support can be configured for the subscriber named default with no additional configuration for RADIUS-based subscribers. This is especially useful when you have separate source/AAA contexts for specific subscribers.

To configure the profile for the subscriber named default, follow the instructions above for configuring a local subscriber and enter the name default.

Feature Description

When a multicast service is set up for the mobile Customer Premises Equipment (CPE), the APN is configured with L2TP tunnel and P-GW works as L2TP Access Concentrator (LAC). To set up the multicast session, the video client/mobile CPE need to send or receive the PIM (Protocol Independent Multicast) message (with TTL=1) to or from Video headend server over SGi L2TP tunnel.

The P-GW follows the default L2TP LAC to inspect and process the encapsulated IP traffic inside the L2TP tunnel. This process prevents certain applications between CPE and LNS that sends TTL=1 traffic to function. Prior to 21.21.1 release, when an IP packet is sent, the Time to Live (TTL) value (for example, 255) was decremented by 1 at each hop. The P-GW dropped the packet with TTL value 0 or 1, decremented (when TTL > 1) the TTL value and the new checksum for the data packet was calculated. In this release, by enabling multicast session over L2TP feature through CLI:

- P-GW ignores the TTL value and forwards the packet.
- The L2TP and regular packets gets differentiated by L2TP tunnel type at `sessmgr_ipv4.c` and it verifies the CLI configuration mode enabled.

Configuring LAC Services



Important

Not all commands, keywords and functions may be available. Functionality is dependent on platform and license(s).

This section provides information and instructions for configuring LAC services on the system allowing it to communicate with peer LNS nodes.



Important This section provides the minimum instruction set for configuring LAC service support on the system. For more information on commands that configure additional parameters and options, refer to the *LAC Service Configuration Mode Commands* chapter in the *Command Line Interface Reference*.

To configure the LAC services on system:

- Step 1** Configure the LAC service on system and bind it to an IP address by applying the example configuration in the *Configuring LAC Service* section.
 - Step 2** *Optional.* Configure LNS peer information if the Tunnel-Service-Endpoint attribute is not configured in the subscriber profile or PDSN compulsory tunneling is supported by applying the example configuration in the *Configuring LNS Peer* section.
 - Step 3** Verify your LAC configuration by following the steps in the *Verifying the LAC Service Configuration* section.
 - Step 4** Save your configuration to flash memory, an external memory device, and/or a network location using the Exec mode command **save configuration**. For additional information on how to verify and save configuration files, refer to the *System Administration Guide* and the *Command Line Interface Reference*.
-

Configuring LAC Service

Use the following example to create the LAC service and bind the service to an IP address:

```
configure
  context <dst_ctxt_name> [-noconfirm]
    lac-service <service_name>
      bind address <ip_address>
    end
```

Notes:

- *<dst_ctxt_name>* is the destination context where you want to configure the LAC service.

Configuring Multicast Services over L2TP

Use the following CLI commands to enable or disable the multicast session over L2TP feature. By default, this feature is disabled.

```
configure
  context context_name
    lac-service service_name
      ttl-ignore
    end
```

Notes:

- **ttl-ignore:** Ignores the TTL value and forwards the packets.

Configuring LNS Peer

Use the following example to configure the LNS peers and load balancing between multiple LNS peers:

```
configure
context <dst_ctxt_name> [ -noconfirm ]
lac-service <service_name>
    tunnel selection-key tunnel-server-auth-id
    peer-lns <ip_address> [encrypted] secret <secret> [crypto-map <map_name>]
    {[encrypted] isakmp-secret <secret> } [description <text>] [ preference <integer>]

    load-balancing { random | balanced | prioritized }
end
```

Notes:

- <dst_ctxt_name> is the destination context where the LAC service is configured.

Verifying the LAC Service Configuration

These instructions are used to verify the LAC service configuration.

Verify that your LAC service configurations were configured properly by entering the following command in Exec Mode in specific context:

```
show lac-service name service_name
```

The output given below is a concise listing of LAC service parameter settings as configured.

```
Service name: vpn1
Context:          isp1
Bind:            Done
Local IP Address: 192.168.2.1
First Retransmission Timeout: 1 (secs)
Max Retransmission Timeout: 8 (secs)
Max Retransmissions: 5
Max Sessions:    500000      Max Tunnels: 32000
Max Sessions Per Tunnel: 512
Data Sequence Numbers: Enabled   Tunnel Authentication: Enabled
Keep-alive interval: 60         Control receive window: 16
Max Tunnel Challenge Length: 16
Proxy LCP Authentication: Enabled
Load Balancing:   Random
Service Status:   Started
Newcall Policy:   None
```

Modifying PDSN Services for L2TP Support

PDSN service modification is required for compulsory tunneling and optional for attribute-based tunneling.

For attribute-based tunneling, a configuration error could occur such that upon successful authentication, the system determines that the subscriber session requires L2TP but cannot determine the name of the context in which the appropriate LAC service is configured from the attributes supplied. As a precautionary, a parameter

has been added to the PDSN service configuration options that will dictate the name of the context to use. It is strongly recommended that this parameter be configured.

This section contains instructions for modifying the PDSN service configuration for either compulsory or attribute-based tunneling.



Important This section provides the minimum instruction set for modifying PDSN service for L2TP support on the system. For more information on commands that configure additional parameters and options, refer to the *LAC Service Configuration Mode Commands* chapter in the *Command Line Interface Reference*.

To configure the LAC services on system:

- Step 1** Modify the PDSN service to support L2TP by associating LAC context and defining tunnel type by applying the example configuration in the *Modifying PDSN Service* section.
 - Step 2** Verify your configuration to modify PDSN service by following the steps in the *Verifying the PDSN Service for L2TP Support* section.
 - Step 3** Save your configuration to flash memory, an external memory device, and/or a network location using the Exec mode command **save configuration**. For additional information on how to verify and save configuration files, refer to the *System Administration Guide* and the *Command Line Interface Reference*.
-

Modifying PDSN Service

Use the following example to modify the PDSN service to support L2TP by associating LAC context and defining tunnel type:

```
configure
  context <source_ctxt_name> [ -noconfirm ]
  pdsn-service <psdn_service_name>
    ppp tunnel-context <lac_context_name>
    ppp tunnel-type { l2tp | none }
  end
```

Notes:

- *<source_ctxt_name>* is the name of the source context containing the PDSN service, which you want to modify for L2TP support.
- *<psdn_service_name>* is the name of the pre-configured PDSN service, which you want to modify for L2TP support.
- *<lac_context_name>* is typically the destination context where the LAC service is configured.

Verifying the PDSN Service for L2TP Support

These instructions are used to verify the PDSN service configuration.

Verify that your PDSN is configured properly by entering the following command in Exec Mode in specific context:

```
show pdsn-service name psdn_service_name
```

The output of this command is a concise listing of PDSN service parameter settings as configured.

Modifying APN Templates to Support L2TP

This section provides instructions for adding L2TP support for APN templates configured on the system.



Important This section provides the minimum instruction set for configuring LAC service support on the system. For more information on commands that configure additional parameters and options, refer to the *LAC Service Configuration Mode Commands* chapter in the *Command Line Interface Reference*.

To configure the LAC services on system:

- Step 1** Modify the APN template to support L2TP with LNS server address and other parameters by applying the example configuration in the *Assigning LNS Peer Address in APN Template* section.
- Step 2** Optional. If L2TP will be used to tunnel transparent IP PDP contexts, configure the APN's outbound username and password by applying the example configuration in the *Configuring Outbound Authentication* section.
- Step 3** Verify your APN configuration by following the steps in the *Verifying the APN Configuration* section.
- Step 4** Save your configuration to flash memory, an external memory device, and/or a network location using the Exec mode command **save configuration**. For additional information on how to verify and save configuration files, refer to the *System Administration Guide* and the *Command Line Interface Reference*.

Assigning LNS Peer Address in APN Template

Use following example to assign LNS server address with APN template:

```
configure
context <dst_ctxt_name> [-noconfirm]
  apn <apn_name>
    tunnel l2tp [ peer-address <lms_address> [ [ encrypted ] secret
<l2tp_secret> ] [ preference <integer> ] [ tunnel-context <l2tp_context_name> ] [
local-address <local_ip_address> ] [ crypto-map <map_name> { [ encrypted ]
isakmp-secret <crypto_secret> } ]
    end
```

Notes:

- *<dst_ctxt_name>* is the name of system destination context in which the APN is configured.
- *<apn_name>* is the name of the pre-configured APN template which you want to modify for the L2TP support.
- *<lms_address>* is the IP address of LNS server node and *<local_ip_address>* is the IP address of system which is bound to LAC service.

Configuring Outbound Authentication

Use the following example to configure the LNS peers and load balancing between multiple LNS peers:

```
configure
  context <dst_ctxt_name> [ -noconfirm ]
    apn <apn_name>
      outbound { [ encrypted ] password <pwd> | username <name> }
    end
```

Notes:

- <dst_ctxt_name> is the destination context where APN template is configured.
- <apn_name> is the name of the pre-configured APN template which you want to modify for the L2TP support.

Verifying the APN Configuration

These instructions are used to verify the APN configuration.

Verify that your APN configurations were configured properly by entering the following command in Exec Mode in specific context:

```
show apn name apn_name
```

The output is a concise listing of APN parameter settings as configured.



APPENDIX M

L2TP Network Server

This chapter describes the support for Layer 2 Tunneling Protocol (L2TP) Network Server (LNS) functionality on Cisco® ASR 5500 chassis and explains how it is configured. The product Administration Guides provide examples and procedures for configuration of basic services on the system. It is recommended that you select the configuration example that best meets your service model, and configure the required elements for that model, as described in the respective product Administration Guide, before using the procedures in this chapter.



Important

The Layer 2 Tunneling Protocol (L2TP) Network Server (LNS) is a licensed Cisco feature. A separate feature license may be required. Contact your Cisco account representative for detailed information on specific licensing requirements. For information on installing and verifying licenses, refer to the *Managing License Keys* section of the *Software Management Operations* chapter in the *System Administration Guide*.

When enabled through the session license and feature use key, LNS functionality is configured as context-level services on the system. LNS services support the termination of L2TP encapsulated tunnels from L2TP Access Concentrators (LACs) in accordance with RFC 2661.



Important

While establishing the L2TP session from LAC to LNS, the PPP connection for the user is established. The server uses CHAP authentication protocol to authenticate the connection. While calculating the CHAP response for the CHAP challenge received by the server, the server does not consider the CHAP password.



Important

The LNS service uses UDP ports 13660 through 13668 as the source port for receiving packets from the LAC. You can force the LNS to only use the standard L2TP port (UDP Port 1701) with the **single-port-mode** LNS service configuration mode command. Refer to the *Command Line Interface Reference* for more information on this command.

- [LNS Service Operation, on page 436](#)
- [Configuring the System to Support LNS Functionality, on page 444](#)

LNS Service Operation

As mentioned previously, LNS functionality on the system is configured via context-level services. LNS services can be configured in the same context as other services supported on the system or in its own context. Each context can support multiple LNS services.

One of the most simple configuration that can be implemented on the system to support Simple IP data applications requires that two contexts (one source and one destination) be configured on the system as shown in the following figure.

Figure 47: LNS Configuration Example

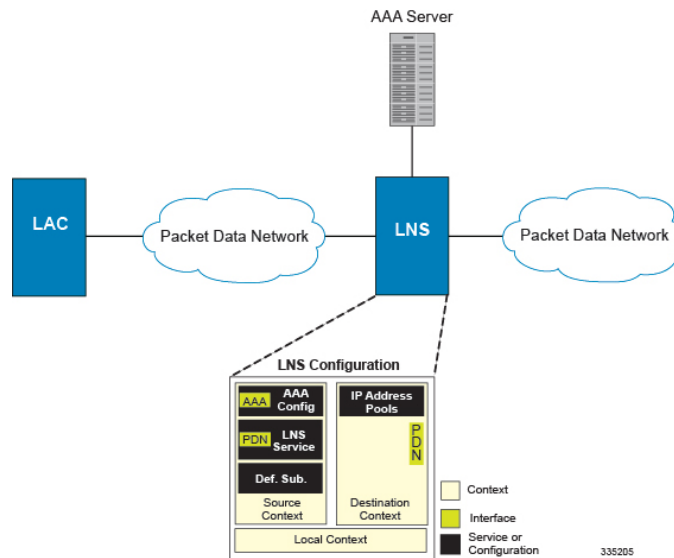

The source context facilitates the LNS service(s) and the PDN and AAA interfaces. The PDN interface is bound to the LNS service and connects L2TP tunnels and sessions from one or more peer LACs. The source context is also be configured to provide AAA functionality for subscriber sessions. The destination context facilitates the packet data network interface(s) and can optionally be configured with pools of IP addresses for assignment to subscriber sessions.

In this configuration, the LNS service in the source context terminates L2TP tunnels from peer LACs and routes the subscriber session data through the destination context to and from a packet data network such as the Internet or a home network.

Information Required

Prior to configuring the system as shown in figure above, a minimum amount of information is required. The following sections describe the information required to configure the source and destination contexts.

Source Context Configuration

The following table lists the information that is required to configure the source context.

Table 45: Required Information for Source Context Configuration

Required Information	Description
Source context name	This is an identification string between 1 and 79 characters (alpha and/or numeric) by which the source context will be recognized by the system.
PDN Interface Configuration	
PDN interface name	<p>This is an identification string between 1 and 79 characters (alpha and/or numeric) by which the interface will be recognized by the system.</p> <p>Multiple names are needed if multiple interfaces will be configured.</p> <p>These PDN interfaces facilitates the L2TP tunnels/sessions from the LAC and are configured in the source context.</p>
IP address and subnet	<p>These will be assigned to the PDN interface.</p> <p>Multiple addresses and/or subnets are needed if multiple interfaces will be configured.</p>
Physical port number	<p>This specifies the physical port to which the interface will be bound. Ports are identified by the chassis slot number where the line card resides in, followed by the number of the physical connector on the line card. For example, port 17/1 identifies connector number 1 on the card in slot 17.</p> <p>A single physical port can facilitate multiple interfaces.</p>
Physical port description	<p>This is an identification string between 1 and 79 characters (alpha and/or numeric) by which the physical port will be recognized by the system.</p> <p>Multiple descriptions are needed if multiple ports will be used.</p> <p>Physical ports are configured within the source context and are used to bind logical PDN interfaces.</p>
Gateway IP address	Used when configuring static routes from the PDN interface(s) to a specific network.
LNS service Configuration	

Required Information	Description
LNS service name	<p>This is an identification string between 1 and 63 characters (alpha and/or numeric) by which the LNS service will be recognized by the system.</p> <p>Multiple names are needed if multiple LNS services will be used.</p> <p>LNS services are configured in the source context.</p>
Authentication protocols used	<p>Specifies how the system handles authentication: using a protocol (such as CHAP, PAP, or MSCHAP), or not requiring any authentication.</p>
Domain alias for NAI-construction	<p>Specifies a context name for the system to use to provide accounting functionality for a subscriber session. This parameter is needed only if the system is configured to support no authentication.</p>
Maximum number of sessions per tunnel	<p>This defines the maximum number of sessions supported by each tunnel facilitated by the LNS service.</p> <p>The number can be configured to any integer value from 1 to 65535. The default is 65535.</p>
Maximum number of tunnels	<p>This defines the maximum number of tunnels supported by the LNS service.</p> <p>The number can be configured to any integer value from 1 to 32000. The default is 32000.</p>
Peer LAC	<p>IP address or network prefix and mask:</p> <p>The IP address of a specific peer LAC for which the LNS service terminates L2TP tunnels. The IP address must be expressed in dotted decimal notation. Multiple peer LACs can be configured.</p> <p>Alternately, to simplify configuration, a group of peer LACs can be specified by entering a network prefix and a mask.</p> <p>Secret:</p> <p>The shared secret used by the LNS to authenticate the peer LAC. The secret can be from 1 to 256 alpha and/or numeric characters and is case sensitive.</p>
AAA Interface Configuration	

Required Information	Description
AAA interface name	<p>This is an identification string between 1 and 79 characters (alpha and/or numeric) by which the interface will be recognized by the system.</p> <p>Multiple names are needed if multiple interfaces will be configured.</p> <p>AAA interfaces will be configured in the source context.</p>
IP address and subnet	<p>These will be assigned to the AAA interface.</p> <p>Multiple addresses and/or subnets are needed if multiple interfaces will be configured.</p>
Physical port number	<p>A single physical port can facilitate multiple interfaces.</p>
Physical port description	<p>This is an identification string between 1 and 79 characters (alpha and/or numeric) by which the physical port will be recognized by the system.</p> <p>Multiple descriptions are needed if multiple ports will be used.</p> <p>Physical ports are configured within the source context and are used to bind logical AAA interfaces.</p>
Gateway IP address	<p>Used when configuring static routes from the AAA interface(s) to a specific network.</p>
RADIUS Server Configuration	

Required Information	Description
RADIUS Authentication server	<p data-bbox="922 283 1484 426">IP Address: Specifies the IP address of the RADIUS authentication server the source context will communicate with to provide subscriber authentication functions. Multiple addresses are needed if multiple RADIUS servers will be configured.</p> <p data-bbox="922 520 1484 615">RADIUS authentication servers are configured within the source context. Multiple servers can be configured and each assigned a priority.</p> <p data-bbox="922 642 1484 894">Shared Secret: The shared secret is a string between 1 and 15 characters (alpha and/or numeric) that specifies the key that is exchanged between the RADIUS authentication server and the source context. A shared secret is needed for each configured RADIUS server.</p> <p data-bbox="922 921 1484 1102">UDP Port Number: Specifies the port used by the source context and the RADIUS authentication server for communications. The UDP port number can be any integer value between 1 and 65535. The default value is 1812.</p>

Required Information	Description
RADIUS Accounting server	<p>IP Address:</p> <p>Specifies the IP address of the RADIUS accounting server that the source context will communicate with to provide subscriber accounting functions.</p> <p>Multiple addresses are needed if multiple RADIUS servers will be configured.</p> <p>RADIUS accounting servers are configured within the source context. Multiple servers can be configured and each assigned a priority.</p> <p>Shared Secret:</p> <p>The shared secret is a string between 1 and 15 characters (alpha and/or numeric) that specifies the key that is exchanged between the RADIUS accounting server and the source context.</p> <p>A shared secret is needed for each configured RADIUS server.</p> <p>UDP Port Number:</p> <p>Specifies the port used by the source context and the RADIUS Accounting server for communications. The UDP port number can be any integer value between 1 and 65535. The default value is 1813.</p>
RADIUS attribute NAS Identifier	Specifies the name by which the source context will be identified in the Access-Request message(s) it sends to the RADIUS server. The name must be between 1 and 32 alpha and/or numeric characters and is case sensitive.
RADIUS NAS IP address	Specifies the IP address of the source context's AAA interface. A secondary IP address interface can optionally be configured.
Default Subscriber Configuration	
"Default" subscriber's IP context name	<p>Specifies the name of the egress context on the system that facilitates the PDN ports.</p> <p>Important For this configuration, the IP context name should be identical to the name of the destination context.</p>

Destination Context Configuration

The following table lists the information that is required to configure the destination context.

Table 46: Required Information for Destination Context Configuration

Required Information	Description
Destination context name	This is an identification string between 1 and 79 characters (alpha and/or numeric) by which the destination context will be recognized by the system. Important For this configuration, the destination context name should not match the domain name of a specific domain.
PDN Interface Configuration	
PDN interface name	This is an identification string between 1 and 79 characters (alpha and/or numeric) by which the interface will be recognized by the system. Multiple names are needed if multiple interfaces will be configured. PDN interfaces are used to connect to a packet network and are configured in the destination context.
IP address and subnet	These will be assigned to the PDN interface. Multiple addresses and/or subnets are needed if multiple interfaces will be configured.
Physical port number	A single physical port can facilitate multiple interfaces.
Physical port description(s)	This is an identification string between 1 and 79 characters (alpha and/or numeric) by which the physical port will be recognized by the system. Multiple descriptions will be needed if multiple ports will be used. Physical ports are configured within the destination context and are used to bind logical PDN interfaces.
Gateway IP address(es)	Used when configuring static routes from the PDN interface(s) to a specific network.
IP Address Pool Configuration (optional)	
IP address pool name(s)	If IP address pools will be configured in the destination context(s), names or identifiers will be needed for them. The pool name can be between 1 and 31 alpha and/or numeric characters and is case sensitive.

Required Information	Description
IP pool addresses	An initial address and a subnet, or a starting address and an ending address, are required for each configured pool. The pool will then consist of every possible address within the subnet, or all addresses from the starting address to the ending address. The pool can be configured as public, private, or static.

How This Configuration Works

The following figure and the text that follows describe how this LNS service configuration with a single source and destination context would be used by the system to terminate an L2TP tunnel.

Figure 48: Call Processing Using a Single Source and Destination Context

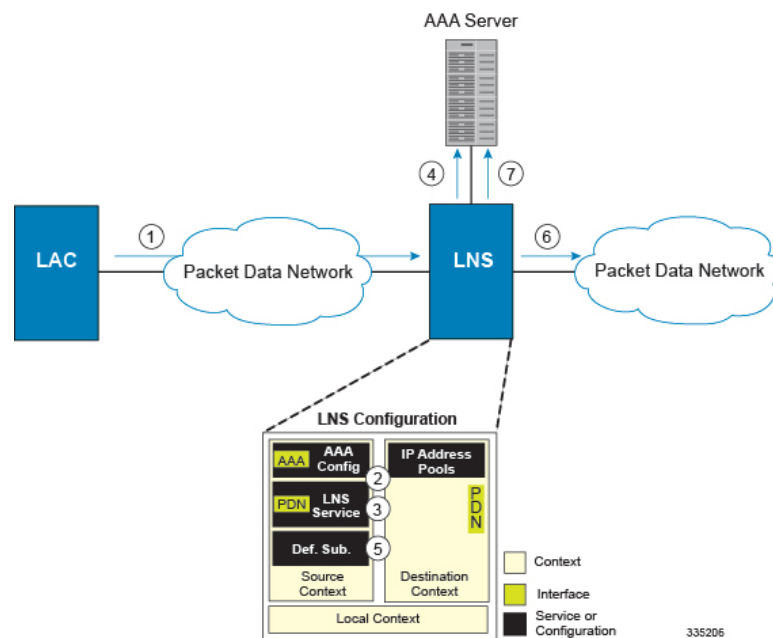

1. An L2TP tunnel request from a peer LAC is received by the LNS service. The tunnel is to facilitate a subscriber session.
2. The LAC and LNS establish the L2TP tunnel according to the procedures defined in RFC 2661. Once the L2TP tunnel is established, subscriber L2TP sessions can be established.
3. The LNS service determines which context to use in providing AAA functionality for the subscriber session if authentication is enabled for the LNS service. For more information on this process, refer *How the System Selects Contexts in System Administration Guide*.

For this example, the result of this process is that LNS service determined that AAA functionality should be provided by the Source context.
4. The system communicates with the AAA server specified in the Source context's AAA configuration to authenticate the subscriber.

5. Upon successful authentication, the LNS service terminates the subscriber's PPP datagrams from the L2TP session and the system determines which egress context to use for the subscriber session. For more information on egress context selection process, refer *How the System Selects Contexts in System Administration Guide*.

The system determines that the egress context is the destination context based on the configuration of either the Default subscriber's ip-context name or from the SN-VPN-NAME or SN1-VPN-NAME attributes that is configured in the subscriber's RADIUS profile.

6. Data traffic for the subscriber session is routed through the PDN interface in the Destination context.
7. Accounting information for the session is sent to the AAA server over the AAA interface.

Configuring the System to Support LNS Functionality

Many of the procedures required to configure the system to support LNS functionality are provided in the *System Administration Guide*. The *System Administration Guide* provides information and procedures for configuring contexts, interfaces and ports, AAA functionality, and IP address pools on the system.

This section provides information and instructions for configuring LNS services on the system allowing it to communicate with peer LAC nodes.



Important

This section provides the minimum instruction set for configuring an LNS service allowing the system to terminate L2TP tunnels and process data sessions. For more information on commands that configure additional LNS service properties, refer *LNS Configuration Mode Commands* chapter in *Command Line Interface Reference*.

To configure the system to provide access control list facility to subscribers:

- Step 1** Create the LNS service and bind it to an interface IP address by applying the example configuration in the *Creating and Binding LNS Service* section.
- Step 2** Specify the authentication parameters for LNS service by applying the example configuration in the *Configuring Authentication Parameters for LNS Service* section.
- Step 3** Configure the maximum number of tunnels supported by the LNS service and maximum number of sessions supported per tunnel by applying the example configuration in the *Configuring Tunnel and Session Parameters for LNS Service* section.
- Step 4** Configure peer LACs for the LNS service by applying the example configuration in the *Configuring Tunnel and Session Parameters for LNS Service* section.
- Step 5** *Optional.* Specify the domain alias designated for the context which the LNS service uses for AAA functionality by applying the example configuration in the *Configuring Domain Alias for AAA Subscribers* section.
- Step 6** Verify your LNS service configuration by following the steps in the *Verifying the LNS Service Configuration* section.
- Step 7** Save your configuration to flash memory, an external memory device, and/or a network location using the Exec mode command **save configuration**. For additional information on how to verify and save configuration files, refer to the *System Administration Guide* and the *Command Line Interface Reference*.

Creating and Binding LNS Service

Use the following example to create the LNS service and bind the IP address to it:

```
configure
  context <dest_ctxt_name> -noconfirm
    lns-service <lns_svc_name> -noconfirm
      bind address <ip_address> [ max-subscribers <max_subscriber> ]
    end
```

Notes:

- LNS service has to be configured in destination context.
- Bind address is the interface address that is to serve as an L2TP PDN interface.
- Multiple addresses on the same IP interface can be bound to different LNS services. However, each address can be bound to only one LNS service. In addition, the LNS service can not be bound to the same interface as other services such as a LAC service.

Configuring Authentication Parameters for LNS Service

Use the following example to authentication parameters for LNS service:

```
configure
  context <dest_ctxt_name>
    lns-service <lns_svc_name>
      authentication { { [ allow-noauth | chap <pref> | mschap <pref>
| | pap <pref> ] } | msid-auth }
    end
```

Note:

- For more information on authentication procedure and priorities, refer **authentication** command section in LNS Configuration Mode Commands chapter of the *Command Line Interface Reference*.

Configuring Tunnel and Session Parameters for LNS Service

Use the following example to configure the tunnel and session parameters for LNS service:

```
configure
  context <dest_ctxt_name>
    lns-service <lns_svc_name>
      max-tunnel <max_tunnels>
      max-session-per-tunnel <max_sessions>
    end
```

Note:

- For more information on tunnel and session related parameters, refer LNS Configuration Mode Commands chapter of the *Command Line Interface Reference*.

Configuring Peer LAC servers for LNS Service

Use the following example to configure the peer LAC servers for LNS service:

```
configure
  context <dest_ctxt_name>
    lns-service <lns_svc_name>
      peer-lac { <lac_ip_address> | <ip_address>/<mask> } [ encrypted ] secret
        <secret_string> [ description <desc_text> ]
      end
  end
```

Note:

- Multiple LACs can be configured with this command. For more information, refer LNS Configuration Mode Commands chapter of the *Command Line Interface Reference*.

Configuring Domain Alias for AAA Subscribers

Use the following example to create the LNS service and bind the IP address to it:

```
configure
  context <dest_ctxt_name> -noconfirm
    lns-service <lns_svc_name> -noconfirm
      nai-construct domain <domain_alias>
    end
  end
```

Notes:

- If this command is enabled, an NAI is constructed for the subscriber in the event that their mobile node does not negotiate CHAP, PAP, or MSCHAP.
- If this option is selected, no further attempts are made to authenticate the user. Instead, the constructed NAI is used for accounting purposes.



Important

This command should only be used if the LNS service is configured to allow "no authentication" using the **authentication allow-noauth** command.

Verifying the LNS Service Configuration

These instructions are used to verify the LNS service configuration.

Verify that your LNS service configuration by entering the following command in Exec Mode:

```
show lns-service name service_name
```

The output of this command displays the configuration of the LNS service and should appear similar to that shown below.

```
Service name: testlns
Context:                               test
Bind:                                     Not Done
Local IP Address:                        0.0.0.0
First Retransmission Timeout:           1 (secs)
```

```
Max Retransmission Timeout:      8 (secs)
Max Retransmissions:             5
Setup Timeout:                   60 (secs)
Max Sessions:                    500000           Max Tunnels:
    32000
Max Sessions Per Tunnel:         65535
Keep-alive Interval:             60              Control Receive Window: 16
Data Sequence Numbers:           Enabled
Tunnel Authentication:           Enabled
Tunnel Switching:                Enabled
Max Tunnel Challenge Length:     16
PPP Authentication:              CHAP 1 PAP 2
Allow Noauthentication:           Disabled       MSID Authentication:      Disabled
No NAI Construct Domain defined
No Default Subscriber defined
IP Src Violation Reneg Limit:    5
IP Src Violation Drop Limit:     10
IP Src Violation Period:         120 (secs)
Service Status:                  Not started
Newcall Policy:                  None
```



APPENDIX **N**

Mobile IP Registration Revocation

This chapter describes Registration Revocation for Mobile-IP and Proxy Mobile-IP and explains how it is configured. The product administration guides provide examples and procedures for configuration of basic services on the system. It is recommended that you select the configuration example that best meets your service model and configure the required elements for that model, as described in this administration guide before using the procedures in this chapter.



Important

This license is enabled by default; however, not all features are supported on all platforms and other licenses may be required for full functionality as described in this chapter.

This chapter includes the following topics:

- [Overview, on page 449](#)
- [Configuring Registration Revocation, on page 450](#)

Overview

Registration Revocation is a general mechanism whereby either the HA or the FA providing Mobile IP functionality to the same mobile node can notify the other mobility agent of the termination of a binding. This functionality provides the following benefits:

- Timely release of Mobile IP resources at the FA and/or HA
- Accurate accounting
- Timely notification to mobile node of change in service

Mobile IP Registration Revocation can be triggered at the FA by any of the following:

- Session terminated with mobile node for whatever reason
- Session renegotiation
- Administrative clearing of calls
- Session Manager software task outage resulting in the loss of FA sessions (sessions that could not be recovered)

**Important**

Registration Revocation functionality is also supported for Proxy Mobile IP. However, only the HA can initiate the revocation for Proxy-MIP calls.

Mobile IP Registration Revocation can be triggered at the HA by any of the following:

- Administrative clearing of calls
- Inter-Access Gateway handoff. This releases the binding at the previous access gateway/FA
- Session Manager software task outage resulting in the loss of FA sessions (for sessions that could not be recovered)
- Session Idle timer expiry (when configured to send Revocation)
- Any other condition under which a binding is terminated due to local policy (duplicate IMSI detected, duplicate home address requested, etc.)

The FA and the HA negotiate Registration Revocation support when establishing a Mobile IP call. Revocation support is indicated to the Mobile Node (MN) from the FA by setting the 'X' bit in the Agent Advertisement to MN. However the MN is not involved in negotiating the Revocation for a call or in the Revocation process. It only gets notified about it. The X bit in the Agent Advertisements is just a hint to the MN that revocation is supported at the FA but is not a guarantee that it can be negotiated with the HA

At the FA, if revocation is enabled and a FA-HA SPI is configured, the Revocation Support extension is appended to the RRQ received from the MN and protected by the FA-HA Authentication Extension. At the HA, if the RRQ is accepted, and the HA supports revocation, the HA responds with an RRP that includes the Revocation Support extension. Revocation support is considered to be negotiated for a binding when both sides have included a Revocation Support Extension during a successful registration exchange.

**Important**

The Revocation Support Extension in the RRQ or RRP must be protected by the FA-HA Authentication Extension. Therefore, an FA-HA SPI must be configured at the FA and the HA for this to succeed.

If revocation is enabled at the FA, but an FA-HA SPI is not configured at the FA for a certain HA, then FA does not send Revocation Support Extension for a call to that HA. Therefore, the call may come up without Revocation support negotiated.

If the HA receives an RRQ with Revocation Support Extension, but not protected by FA-HA Auth Extension, it will be rejected with "FA Failed Authentication" error.

If the FA receives a RRP with Revocation Support Extension, but not protected by FA-HA Auth Extension, it will be rejected with "HA Failed Authentication" error.

Also note that Revocation support extension is included in the initial, renewal or handoff RRQ/RRP messages. The Revocation extension is not included in a Deregistration RRQ from the FA and the HA will ignore them in any Deregistration RRQs received.

Configuring Registration Revocation

Support for MIP Registration Revocation requires the following configurations:

- **FA service(s):** Registration Revocation must be enabled and operational parameters optionally configured.
- **HA service(s):** Registration Revocation must be enabled and operational parameters optionally configured.

**Important**

These instructions assume that the system was previously configured to support subscriber data sessions for a core network service with FA and/or an HA according to the instructions described in the respective product Administration Guide.

**Important**

Commands used in the configuration samples in this section provide base functionality to the extent that the most common or likely commands and/or keyword options are presented. In many cases, other optional commands and/or keyword options are available. Refer to the *Command Line Interface Reference* for complete information regarding all commands.

Configuring FA Services

Configure FA services to support MIP Registration Revocation by applying the following example configuration:

```
configure
  context <context_name>
    fa-service <fa_service_name>
      revocation enable
      revocation max-retransmission <number>
      revocation retransmission-timeout <time>
    end
```

Save your configuration to flash memory, an external memory device, and/or a network location using the Exec mode command **save configuration**. For additional information on how to verify and save configuration files, refer to the *System Administration Guide* and the *Command Line Interface Reference*.

Configuring HA Services

Configure HA services to support MIP Registration Revocation by applying the following example configuration:

```
configure
  context <context_name>
    ha-service <ha_service_name>
      revocation enable
      revocation max-retransmission <number>
      revocation retransmission-timeout <time>
    end
```

Save your configuration to flash memory, an external memory device, and/or a network location using the Exec mode command **save configuration**. For additional information on how to verify and save configuration files, refer to the *System Administration Guide* and the *Command Line Interface Reference*.



APPENDIX 0

Policy Forwarding

This chapter provides information on configuring an enhanced, or extended, service. The product administration guides provide examples and procedures for configuration of basic services on the system. It is recommended that you select the configuration example that best meets your service model and configure the required elements for that model before using the procedures in this chapter.

Sections in this chapter include:

- [Overview, on page 453](#)
- [IP Pool-based Next Hop Forwarding, on page 454](#)
- [Subscriber-based Next Hop Forwarding, on page 454](#)
- [ACL-based Policy Forwarding, on page 454](#)

Overview

The system can be configured to automatically forward data packets to a predetermined network destination. This can be done in one of three ways:

- **IP Pool-based Next Hop Forwarding** - Forwards data packets based on the IP pool from which a subscriber obtains an IP address.
- **ACL-based Policy Forwarding** - Forwards data packets based on policies defined in Access Control Lists (ACLs) and applied to contexts or interfaces.
- **Subscriber specific Next Hop Forwarding** - Forwards all packets for a specific subscriber.

The simplest way to forward subscriber data is to use IP Pool-based Next Hop Forwarding. An IP pool is configured with the address of a next hop gateway and data packets from all subscribers using the IP pool are forward to that gateway.

Subscriber Next Hop forwarding is also very simple. In the subscriber configuration a nexthop forwarding address is specified and all data packets for that subscriber are forwarded to the specified nexthop destination.

ACL-based Policy Forwarding gives you more control on redirecting data packets. By configuring an Access Control List (ACL) you can forward data packets from a context or an interface by different criteria, such as; source or destination IP address, ICMP type, or TCP/UDP port numbers.

ACLs are applied first. If ACL-based Policy Forwarding and Pool-based Next Hop Forwarding or Subscriber are configured, data packets are first redirected as defined in the ACL, then all remaining data packets are redirected to the next hop gateway defined by the IP pool or subscriber profile.

IP Pool-based Next Hop Forwarding

When an IP pool in a destination context has a Next Hop Forwarding address specified, any subscriber that obtains an IP address from that IP pool has all data coming from the mobile node automatically forwarded to the specified Next Hop Forwarding address.

For more information on creating IP pools, refer to the *System Administration Guide* and for additional information on the **ip pool** command, refer to the *Command Line Interface Reference*.

Configuring IP Pool-based Next Hop Forwarding

Configure Next Hop Forwarding on an existing IP Pool in a destination context by applying the following example configuration:

```
configure
  context <context_name>
    ip pool <pool_name> nexthop-forwarding-address <forwarding_ip_address>
  end
```

Save the configuration to flash memory, an external memory device, and/or a network location using the Exec mode command **save configuration**. For additional information on how to verify and save configuration files, refer to the *System Administration Guide* and the *Command Line Interface Reference*.

Subscriber-based Next Hop Forwarding

When a subscriber configuration has a Next Hop Forwarding address specified, any sessions authenticated as that subscriber have all data coming from the mobile node automatically forwarded to the specified Next Hop Forwarding address.

Configuring Subscriber-based Next Hop Forwarding

Configure Next Hop Forwarding for a specific subscriber by applying the following example configuration:

```
configure
  context <context_name>
    subscriber name <subs_name>
      nexthop-forwarding-address <forwarding_ip_address>
    end
```

Save the configuration to flash memory, an external memory device, and/or a network location using the Exec mode command **save configuration**. For additional information on how to verify and save configuration files, refer to the *System Administration Guide* and the *Command Line Interface Reference*.

ACL-based Policy Forwarding

ACL-based Policy Forwarding is a feature in the system that forwards subscriber data based on policies defined in Access Control Lists (ACLs). When ACLs are applied to access groups, priorities are given to the ACLS.

The ACL applied with the highest priority is used to define the policy that is used for forwarding the subscriber data.



Important Refer to *Access Control Lists* for additional information on creating and using ACLs.

Configuring ACL-based Policy Forwarding

Configure ACL-based Policy Forwarding by applying the following example configuration:

```
configure
  context <context_name>
    ip access-list <acl_name>
      redirect <interface_name> <next_hop_address> <criteria>
    exit
```

The following example specifies that any IP packet coming from any system on the 192.168.55.0 network that has a destination host address of 192.168.80.1 is to be redirected, or forwarded, through the system interface named *interface2* to the host at 192.168.23.12:

```
redirect interface2 192.168.23.12 ip 192.168.55.0 255.255.255.0 host 192.168.80.1
```

Save the configuration to flash memory, an external memory device, and/or a network location using the Exec mode command **save configuration**. For additional information on how to verify and save configuration files, refer to the *System Administration Guide* and the *Command Line Interface Reference*.

Applying the ACL to an IP Access Group

To apply the ACL to the IP access group for the current destination context, go to *Applying the ACL to a Destination Context*.

To apply the ACL to the IP access group for an interface in the current destination context, go to [Applying the ACL to an Interface in a Destination Context, on page 455](#).

Applying the ACL to a Destination Context

Step 1 At the context configuration mode prompt, enter the following command:

```
ip access-group <acl_name> { in | out } <priority-value>
```

Step 2 Save the configuration to flash memory, an external memory device, and/or a network location using the Exec mode command **save configuration**. For additional information on how to verify and save configuration files, refer to the *System Administration Guide* and the *Command Line Interface Reference*.

Applying the ACL to an Interface in a Destination Context

Step 1 Set parameters for inbound data by applying the following example configuration:

```
configure
  context <context_name>
    interface <interface_name>
      ip access-group <acl_name> in <priority-value>
    end
```

Step 2 Set parameters for outbound data by applying the following example configuration:

```
configure
  context <context_name>
    interface <interface_name>
      ip access-group <acl_name> out <priority-value>
    end
```

Step 3 Save the configuration to flash memory, an external memory device, and/or a network location using the Exec mode command **save configuration**. For additional information on how to verify and save configuration files, refer to the *System Administration Guide* and the *Command Line Interface Reference*.



APPENDIX **P**

Pre-paid Billing

This chapter provides information on configuring an enhanced, or extended, service. The product administration guides provides examples and procedures for configuration of basic services on the system. It is recommended that you select the configuration example that best meets your service model and configure the required elements for that model before using the procedures in this chapter.

This chapter includes the following topics:

- [Overview, on page 457](#)
- [Configuring Standard 3GPP2 Pre-paid Billing, on page 458](#)
- [Configuring Pre-paid Billing With Custom Behavior, on page 459](#)
- [3GPP2 Pre-paid Attributes, on page 461](#)
- [Pre-paid Attributes, on page 464](#)

Overview

The system supports pre-paid billing for subscriber accounts that use RADIUS Accounting.

The system supports two methods of implementing Pre-paid Billing Support; Standard 3GPP2 Pre-paid Billing and Custom Pre-paid Billing. The 3GPP2 standard is the recommended implementation.

3GPP2 Standard Pre-paid Billing Overview

The prepaid packet data service allows a user to purchase access to the network in advance, based on either volume or duration. When a user connects to a service, the Prepaid Client (PPC) contacts the Prepaid Server (PPS) and verifies that the user has available credits for the service. When a user runs out of credits, service is terminated until the user purchases additional credits.

The Prepaid Data Service implementation is compliant with 3GPP2 IS-835-C. This solution provides a standards based implementation that can effectively interoperate with additional vendors equipment when required. The system primarily uses the PPAC (PrePaid Accounting Capability) and PPAQ (PrePaid Accounting Quota) VSAs to implement PrePaid service. The PPAC VSA is used to determine the capabilities of the PPC. When the PPC sends the PPAC VSA it specifies if it supports duration, volume or both types of PrePaid service. When the PPS sends a PPAC VSA it specifies the type of PrePaid service to use for the particular session. The PPAQ VSA specifies the characteristics of the PrePaid accounting service. This includes quota & threshold values for both duration and volume PrePaid service. Through the use of these VSAs, the PPC and PPS communicate the status of the session and when the user has run out of quota, the service can be terminated.

The PrePaid Client resides on the system and communicates with the PPS through the use of RADIUS messages exchanged with the RADIUS server.

Custom Pre-paid Billing Overview

In the Access-Accept from the RADIUS server the system receives attributes which indicate the number of byte credits available for the subscriber. Byte throughput can be pre-paid for traffic inbound to the system, outbound from the system, or an amount that combines both inbound and outbound traffic. Five attributes are used: one for traffic inbound to the system, one for traffic outbound from the system, one that combines traffic in both directions, one that only indicates that the user should be re-authenticated regardless of the byte counters, and one for the low watermark in percent.

The low watermark value is multiplied by the number of byte credits granted in the Access-Accept to arrive at a threshold. Once the number of byte credits remaining is lower than this number, a new Access-Request is issued. If the Access-Request is issued because the Low Watermark has been reached, then a new Low Watermark is calculated from the number of byte credits granted in the Access-Accept, but only if the number of byte credits granted is a non-zero value. If the Access-Request is issued for any other reason, then the Low Watermark is not re-calculated.

The system re-authorizes an active subscriber that has used up its byte credits by issuing a RADIUS Access-Request to the RADIUS server. A valid Access-Reject or a RADIUS timeout results in immediate disconnect of the subscriber session. An Access-Accept without attributes that authorize more byte credits allows the subscriber session to continue with the remaining credits. An Access-Accept with attributes containing byte credits results in the addition of these byte credits to the subscriber session, and the continuation of the session until the subscriber session byte credits have been reduced to the low watermark received in the access accept. If not received, it defaults to 10.

The system continues to service the subscriber session while the RADIUS request for re-authorization is in process. If the counter reaches zero before the response the subscriber session is terminated immediately.

You can configure Pre-paid Billing support for standard 3GPP2 behavior or custom behavior where you can specify whether or to measure the byte-count on compressed or non-compressed data, set a low-watermark for accounting, and specify a credit renewal interval in the default subscriber configuration for a context or a domain alias.

License Requirements

The Pre-paid Billing is a licensed Cisco feature. A separate feature license may be required. Contact your Cisco account representative for detailed information on specific licensing requirements. For information on installing and verifying licenses, refer to the *Managing License Keys* section of the *Software Management Operations* chapter in the *System Administration Guide*.

Configuring Standard 3GPP2 Pre-paid Billing

This section describes how to enable standard 3GPP2 pre-paid billing support.

**Important**

Commands used in the configuration samples in this section provide base functionality to the extent that the most common or likely commands and/or keyword options are presented. In many cases, other optional commands and/or keyword options are available. Refer to the *Command Line Interface Reference* for complete information regarding all commands.

Enable pre-paid billing for the default subscriber by applying the following example configuration:

```
configure
  context <context_name>
    subscriber default
      prepaid 3gpp2 accounting
    end
```

Enable pre-paid billing for the default subscriber of a domain alias by applying the following example configuration:

```
configure
  context <context_name>
    subscriber name <alias_def_sub>
      prepaid 3gpp2 accounting
    end
```

Notes:

- You may add the optional keyword **no-final-access-request** to the **prepaid 3gpp2 accounting** command to stop sending the final online access-request on termination of 3GPP2 prepaid sessions.
- Optional commands: If both duration and volume attributes are received, default preference is given to the duration attribute. To set the preference to the volume attribute, enter the following command:

```
prepaid 3gpp2 preference volume
```

Note that this command alone does not enable pre-paid support. The **prepaid 3gpp2 accounting** command must be executed as shown to enable pre-paid support.

If you are using duration-based quota usage accounting, use the following command to define what behavior specifies the end of the billing duration. The default behavior is the duration quota algorithm set to current-time.

```
prepaid 3gpp2 duration-quota final-duration-algorithm [ current-time | last-airlink-activity-time | last-user-layer3-activity-time ]
```

Note that this command alone does not enable pre-paid support. The **prepaid 3gpp2 accounting** command must be executed as shown to enable pre-paid support.

Save the configuration to flash memory, an external memory device, and/or a network location using the Exec mode command **save configuration**. For additional information on how to verify and save configuration files, refer to the *System Administration Guide* and the *Command Line Interface Reference*.

Configuring Pre-paid Billing With Custom Behavior

This section describes how to enable Pre-paid billing support with custom behavior.



Important If RADIUS attributes are present that conflict with the custom pre-paid settings, the values set by the RADIUS attributes take precedence.



Important Pre-paid billing support is not available for local subscribers. Even though you can set pre-paid parameters for a local subscriber from the CLI, these settings have no effect on a subscriber session.



Important Commands used in the configuration samples in this section provide base functionality to the extent that the most common or likely commands and/or keyword options are presented. In many cases, other optional commands and/or keyword options are available. Refer to the *Command Line Interface Reference* for complete information regarding all commands.

Enable custom pre-paid billing for the default subscriber by applying the following example configuration:

```
configure
  context <context_name>
    subscriber default
      prepaid custom
    end
```

Enable custom pre-paid billing for the default subscriber of a domain alias by applying the following example configuration:

```
configure
  context <context_name>
    subscriber name <alias_def_sub>
      prepaid custom
    end
```

Notes:

- *Optional:* To have custom pre-paid byte credits based on the flow of compressed traffic, use the following command:
prepaid custom byte-count compressed
- *Optional:* Set the low-watermark for remaining byte credits. This is a percentage of the subscriber session's total credits. When the low-watermark is reached a new RADIUS access-request is sent to the RADIUS server to retrieve more credits. To set the low watermark percentage, enter the following command:
prepaid custom low-watermark percent <percentage>
- *Optional:* Set the time in seconds to wait before sending a new RADIUS access-request to the RADIUS server to retrieve more credits by entering the following command:
prepaid custom renewal interval <seconds>
- Save the configuration to flash memory, an external memory device, and/or a network location using the Exec mode command **save configuration**. For additional information on how to verify and save configuration files, refer to the *System Administration Guide* and the *Command Line Interface Reference*.

3GPP2 Pre-paid Attributes

Use the attributes listed in the following table to configure a subscriber for 3GPP2 pre-paid billing;

Attribute	Sub-attribute	Description
3GPP2-Pre-Paid-Acct-Capability		This attribute is for setting the prepaid accounting capability.
	Available-In-Client	The optional Available-In-Client Sub-Type, generated by the PrePaid client, indicates the PrePaid Accounting capabilities of the client in the PDSN or HA and shall be bitmap encoded.
	Selected-For-Session	The optional Selected-For-Session Sub-Type, generated by the PrePaid server, indicates the PrePaid Accounting capability to be used for a given session.
3GPP2-Pre-Paid-Accounting-Quota		This attribute specifies the characteristics for PrePaid accounting of the volume and/or duration of a packet data session. It shall be present in all on-line RADIUS Access-Request and on-line RADIUS Access-Accept messages and may be included in other RADIUS Access-Accept messages. Non-used Sub-Types by the PPC and PPS shall be omitted.
	Quota-Identifier	The Quota-Identifier Sub-Type is generated by the PrePaid server at allocation of a Volume and/or Duration Quota. The on-line quota update RADIUS Access-Request message sent from the PPC to the PPS shall include a previously received Quota-Identifier.

Attribute	Sub-attribute	Description
	Volume-Quota	The optional Volume-Quota Sub-Type is only present if Volume Based charging is used. In RADIUS Access-Accept message (PPS to PPC direction), it indicates the Volume (in octets) allocated for the session by the PrePaid server. In on-line RADIUS Access-Request message (PPC to PPS direction), it indicates the total used volume (in octets) for both forward and reverse traffic applicable to PrePaid accounting ¹³ . If a Tariff Switch condition was reached during the session, this Sub-Type contains the complete (before and after) volume used, while the Volume-Used-After-Tariff-Switch attribute contains the volume used after the tariff switch condition.
	Volume-Quota-Overflow	The optional Volume-Quota-Overflow Sub-Type is used to indicate how many times the Volume-Quota counter has wrapped around 232 over the course of the service being provided.
	Volume-Threshold	The Volume-Threshold Sub-Type shall always be present if Volume-Quota is present in a RADIUS Access-Accept message (PPS to PPC direction). It is generated by the PrePaid server and indicates the volume (in octets) that shall be used before requesting quota update. This threshold should not be larger than the Volume-Quota.
	Volume-Threshold-Overflow	The optional Volume-Threshold-Overflow Sub-Type is used to indicate how many times the Volume-Threshold counter has wrapped around 232 over the course of the service being provided.

Attribute	Sub-attribute	Description
	Duration-Quota	The optional Duration-Quota Sub-Type is only present if Duration Based charging is used. In RADIUS Access-Accept message (PPS to PPC direction), it indicates the Duration (in seconds) allocated for the session by the PrePaid server. In on-line RADIUS Access-Accept message (PPC to PPS direction), it indicates the total Duration (in seconds) since the start of the accounting session related to the Quota-ID.
	Duration-Threshold	The Duration-Threshold Sub-Type shall always be present if Duration-Quota is present in a RADIUS Access-Accept message (PPS to PPC direction). It represents the duration (in seconds) that shall be used by the session before requesting quota update. This threshold should not be larger than the Duration-Quota and shall always be sent with the Duration-Quota.
	Update-Reason	The Update-Reason Sub-Type shall be present in the on-line RADIUS Access-Request message (PPC to PPS direction). It indicates the reason for initiating the on-line quota update operation. Update reasons 4, 5, 6, 7 and 8 indicate that the associated resources are released at the client side, and therefore the PPS shall not allocate a new quota in the RADIUS Access-Accept message.

Attribute	Sub-attribute	Description
	Pre-Paid-Server	The optional, multi-value PrePaid-Server indicates the address of the serving PrePaid System. If present, the Home RADIUS server uses this address to route the message to the serving PrePaid Server. The attribute may be sent by the Home RADIUS server. If present in the incoming RADIUS Access-Accept message, the PDSN shall send this attribute back without modifying it in the subsequent RADIUS Access-Request message, except for the first one. If multiple values are present, the PDSN shall not change the order of the attributes.

These attributes can be found in the following dictionaries:

- 3gpp2
- 3gpp2-835
- starent
- starent-835
- starent-vs1
- starent-vs1-835

For more information, refer to the *AAA and GTP Interface Administration and Reference*.

Pre-paid Attributes

Use the attributes listed in the following table to configure a subscriber for pre-paid billing;

Attribute	Description
SN-Prepaid-Inbound-Octets	If only SN-Prepaid-Inbound-Octets is in the Access-Accept, and the others are not, then the number of outbound credits is infinite.
SN-Prepaid-Outbound-Octets	If only SN-Prepaid-Outbound-Octets is in the Access-Accept, and the others are not, then the number of inbound credits is infinite.
SN-Prepaid-Total-Octets	If only SN-Prepaid-Total-Octets is in the Access-Accept, and the others are not, then pre-paid credits is only enforced on the total byte throughput.

Attribute	Description
SN-Prepaid-Timeout	SN-Prepaid-Timeout can be used alone or in combination with the other attributes. This integer RADIUS attribute includes a time limit in seconds. Regardless of the values of the Octet counters, the session should send a new authorization request upon timer expiration.
SN-Prepaid-Watermark	SN-Prepaid-Watermark is optional with any of the attributes. If it is not included it defaults to the CLI default subscriber configuration, which defaults to a value of 10. This watermark applies to any of the pre-paid attributes being enforced.

These attributes can be found in the following dictionaries:

- starent
- starent-vs1
- starent-835
- starent-vs1-835
- custom1 through custom9

Refer to the *AAA and GTP Interface Administration and Reference* for more details.



APPENDIX Q

Proxy-Mobile IP

This chapter describes system support for Proxy Mobile IP and explains how it is configured. The product administration guides provide examples and procedures for configuration of basic services on the system. It is recommended that you select the configuration example that best meets your service model before using the procedures in this chapter.

Proxy Mobile IP provides a mobility solution for subscribers with mobile nodes (MNs) capable of supporting only Simple IP.

This chapter includes the following sections:

- [Overview, on page 467](#)
- [How Proxy Mobile IP Works in 3GPP2 Network, on page 470](#)
- [How Proxy Mobile IP Works in 3GPP Network, on page 477](#)
- [How Proxy Mobile IP Works in WiMAX Network, on page 482](#)
- [How Proxy Mobile IP Works in a WiFi Network with Multiple Authentication, on page 488](#)
- [Configuring Proxy Mobile-IP Support, on page 495](#)

Overview

Proxy Mobile IP provides mobility for subscribers with MNs that do not support the Mobile IP protocol stack.



Important

Proxy Mobile IP is a licensed Cisco feature. A separate feature license may be required. Contact your Cisco account representative for detailed information on specific licensing requirements. For information on installing and verifying licenses, refer to the *Managing License Keys* section of the *Software Management Operations* chapter in the *System Administration Guide*.

The Proxy Mobile IP feature is supported for various products. The following table indicates the products on which the feature is supported and the relevant sections within the chapter that pertain to that product.

Table 47: Applicable Products and Relevant Sections

Applicable Product(s)	Refer to Sections
PDSN	<ul style="list-style-type: none"> • Proxy Mobile IP in 3GPP2 Service, on page 469 • How Proxy Mobile IP Works in 3GPP2 Network, on page 470 • Configuring FA Services, on page 496 • Configuring Proxy MIP HA Failover, on page 497 • Configuring HA Services • Configuring Subscriber Profile RADIUS Attributes, on page 497 • RADIUS Attributes Required for Proxy Mobile IP, on page 498 • Configuring Local Subscriber Profiles for Proxy-MIP on a PDSN, on page 499 • Configuring Default Subscriber Parameters in Home Agent Context, on page 500
GGSN	<ul style="list-style-type: none"> • Proxy Mobile IP in 3GPP Service, on page 470 • How Proxy Mobile IP Works in 3GPP Network, on page 477 • Configuring FA Services, on page 496 • Configuring Proxy MIP HA Failover, on page 497 • Configuring HA Services • Configuring Subscriber Profile RADIUS Attributes, on page 497 • RADIUS Attributes Required for Proxy Mobile IP, on page 498 • Configuring Default Subscriber Parameters in Home Agent Context, on page 500 • Configuring APN Parameters, on page 500

Applicable Product(s)	Refer to Sections
ASN GW	<ul style="list-style-type: none"> • Proxy Mobile IP in WiMAX Service, on page 470 • How Proxy Mobile IP Works in WiMAX Network, on page 482 • Configuring FA Services, on page 496 • Configuring Proxy MIP HA Failover, on page 497 • Configuring HA Services • Configuring Subscriber Profile RADIUS Attributes, on page 497 • RADIUS Attributes Required for Proxy Mobile IP, on page 498 • Configuring Default Subscriber Parameters in Home Agent Context, on page 500
PDIF	<ul style="list-style-type: none"> • How Proxy Mobile IP Works in a WiFi Network with Multiple Authentication, on page 488 • Configuring FA Services, on page 496 • Configuring Proxy MIP HA Failover, on page 497 • Configuring HA Services • Configuring Subscriber Profile RADIUS Attributes, on page 497 • RADIUS Attributes Required for Proxy Mobile IP, on page 498 • Configuring Default Subscriber Parameters in Home Agent Context, on page 500

Proxy Mobile IP in 3GPP2 Service

For subscriber sessions using Proxy Mobile IP, R-P and PPP sessions get established between the MN and the PDSN as they would for a Simple IP session. However, the PDSN/FA performs Mobile IP operations with an HA (identified by information stored in the subscriber's profile) on behalf of the MN (i.e. the MN is only responsible for maintaining the Simple IP PPP session with PDSN).

The MN is assigned an IP address by either the PDSN/FA or the HA. Regardless of its source, the address is stored in a mobile binding record (MBR) stored on the HA. Therefore, as the MN roams through the service provider's network, each time a hand-off occurs, the MN will continue to use the same IP address stored in the MBR on the HA.

Note that unlike Mobile IP-capable MNs that can perform multiple sessions over a single PPP link, Proxy Mobile IP allows only a single session over the PPP link. In addition, simultaneous Mobile and Simple IP sessions will not be supported for an MN by the FA that is currently facilitating a Proxy Mobile IP session for the MN.

The MN is assigned an IP address by either the HA, a AAA server, or on a static-basis. The address is stored in a mobile binding record (MBR) stored on the HA. Therefore, as the MN roams through the service provider's network, each time a hand-off occurs, the MN will continue to use the same IP address stored in the MBR on the HA.

Proxy Mobile IP in 3GPP Service

For IP PDP contexts using Proxy Mobile IP, the MN establishes a session with the GGSN as it normally would. However, the GGSN/FA performs Mobile IP operations with an HA (identified by information stored in the subscriber's profile) on behalf of the MN (i.e. the MN is only responsible for maintaining the IP PDP context with the GGSN, no Agent Advertisement messages are communicated with the MN).

The MN is assigned an IP address by either the HA, a AAA server, or on a static-basis. The address is stored in a mobile binding record (MBR) stored on the HA. Therefore, as the MN roams through the service provider's network, each time a hand-off occurs, the MN will continue to use the same IP address stored in the MBR on the HA.

Proxy Mobile IP can be performed on a per-subscriber basis based on information contained in their user profile, or for all subscribers facilitated by a specific APN. In the case of non-transparent IP PDP contexts, attributes returned from the subscriber's profile take precedence over the configuration of the APN.

Proxy Mobile IP in WiMAX Service

For subscriber sessions using Proxy Mobile subscriber sessions get established between the MN and the ASN GW as they would for a Simple IP session. However, the ASN GW/FA performs Mobile IP operations with an HA (identified by information stored in the subscriber's profile) on behalf of the MN (i.e. the MN is only responsible for maintaining the Simple IP subscriber session with ASN GW).

The MN is assigned an IP address by either the ASN GW/FA or the HA. Regardless of its source, the address is stored in a mobile binding record (MBR) stored on the HA. Therefore, as the MN roams through the service provider's network, each time a hand-off occurs, the MN will continue to use the same IP address stored in the MBR on the HA.

Note that unlike Mobile IP-capable MNs that can perform multiple sessions over a single session link, Proxy Mobile IP allows only a single session over the session link. In addition, simultaneous Mobile and Simple IP sessions will not be supported for an MN by the FA that is currently facilitating a Proxy Mobile IP session for the MN.

How Proxy Mobile IP Works in 3GPP2 Network

This section contains call flows displaying successful Proxy Mobile IP session setup scenarios. There are multiple scenarios that are dependant on how the MN receives an IP address. The following scenarios are described:

- **Scenario 1:** The AAA server that authenticates the MN at the PDSN allocates an IP address to the MN. Note that the PDSN does not allocate an address from its IP pools.

- **Scenario 2:** The HA assigns an IP address to the MN from one of its locally configured dynamic pools.

Scenario 1: AAA server and PDSN/FA Allocate IP Address

The following figure and table display and describe a call flow in which the MN receives its IP address from the AAA server and PDSN/FA.

Figure 49: AAA/PDSN Assigned IP Address Proxy Mobile IP Call Flow

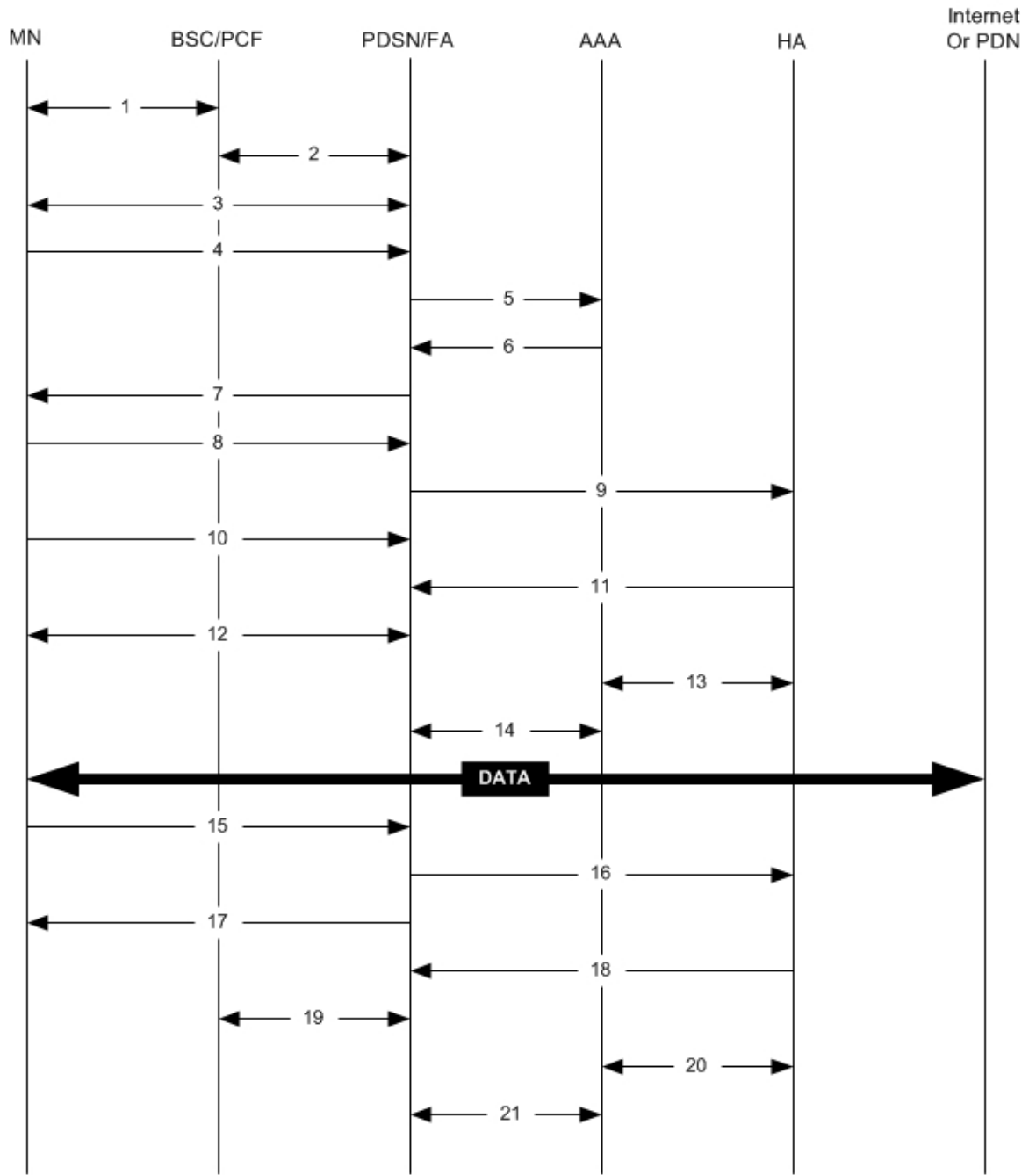

335164

Table 48: AAA/PDSN Assigned IP Address Proxy Mobile IP Call Flow Description

Step	Description
1	Mobile Node (MN) secures a traffic channel over the airlink with the RAN through the BSC/PCF.

Step	Description
2	The PCF and PDSN/FA establish the R-P interface for the session.
3	The PDSN/FA and MN negotiate Link Control Protocol (LCP).
4	Upon successful LCP negotiation, the MN sends a PPP Authentication Request message to the PDSN/FA.
5	The PDSN/FA sends an Access Request message to the RADIUS AAA server.
6	The RADIUS AAA server successfully authenticates the subscriber and returns an Access Accept message to the PDSN/FA. The Accept message may contain various attributes to be assigned to the MN including the MN's Home Address (IP address) and the IP address of the HA to use.
7	The PDSN/FA sends a PPP Authentication Response message to the MN.
8	The MN sends an Internet Protocol Control Protocol (IPCP) Configuration Request message to the PDSN/FA with an MN address of 0.0.0.0.
9	The PDSN/FA forwards a Proxy Mobile IP Registration Request message to the HA. The message includes fields such as the MN's home address, the IP address of the FA (the care-of-address), and the FA-HA extension (security parameter index (SPI)).
10	While the FA is communicating with the HA, the MN may send additional IPCP Configuration Request messages.
11	The HA responds with a Proxy Mobile IP Registration Response after validating the home address against its pool. The HA also creates a mobile binding record (MBR) for the subscriber session.
12	The MN and the PDSN/FA negotiate IPCP. The result is that the MN is assigned the home address originally specified by the AAA server.
13	While the MN and PDSN/FA are negotiating IPCP, the HA and AAA server initiate accounting.

Step	Description
14	Upon completion of the IPCP negotiation, the PDSN/FA and AAA server initiate accounting fully establishing the session allowing the MN to send/receive data to/from the PDN.
15	Upon completion of the session, the MN sends an LCP Terminate Request message to the PDSN to end the PPP session.
16	The PDSN/FA sends a Proxy Mobile IP De-registration Request message to the HA.
17	The PDSN/FA send an LCP Terminate Acknowledge message to the MN ending the PPP session.
18	The HA sends a Proxy Mobile IP De-Registration Response message to the FA terminating the Pi interface
19	The PDSN/FA and the PCF terminate the R-P session.
20	The HA and the AAA server stop accounting for the session.
21	The PDSN and the AAA server stop accounting for the session.

Scenario 2: HA Allocates IP Address

The following figure and table display and describe a call flow in which the MN receives its IP address from the HA.

Figure 50: HA Assigned IP Address Proxy Mobile IP Call Flow

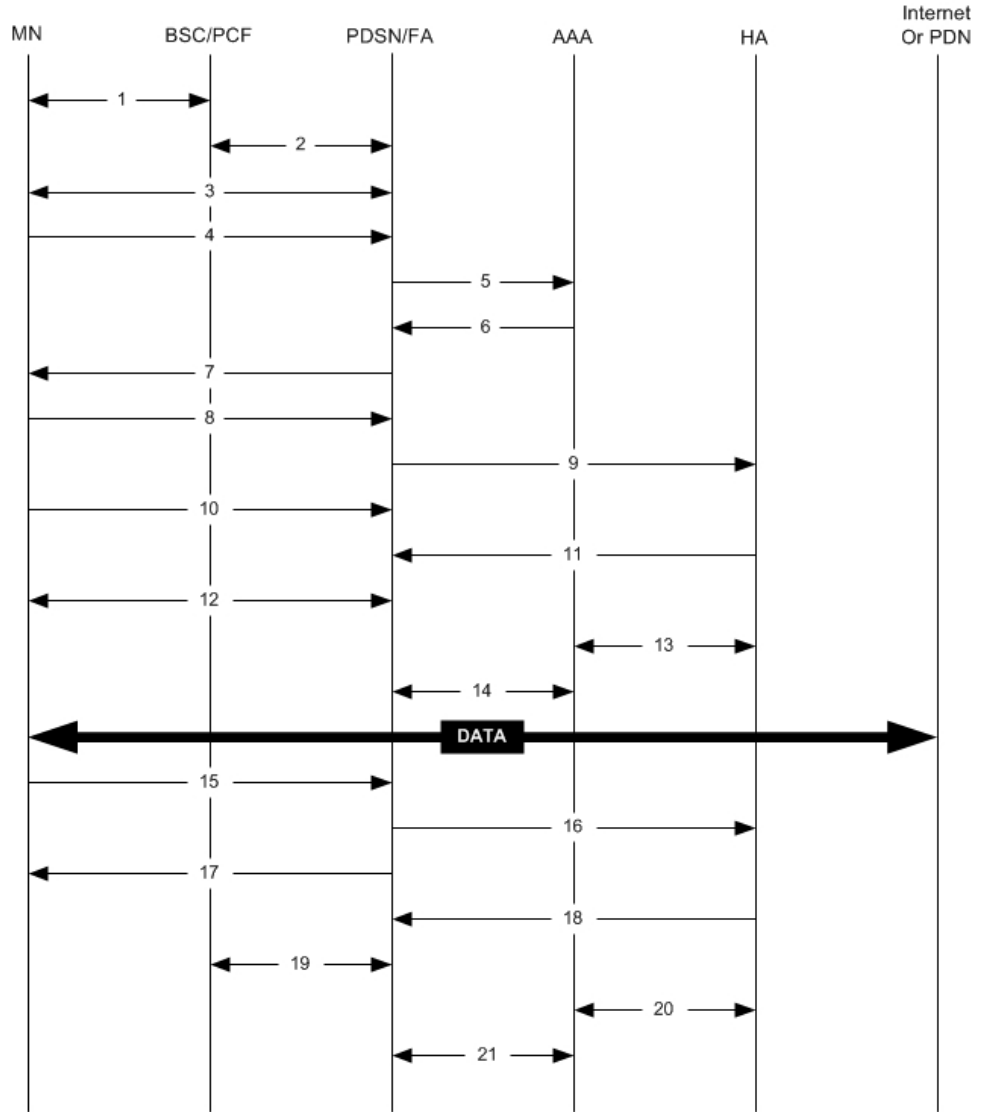

335164

Table 49: HA Assigned IP Address Proxy Mobile IP Call Flow Description

Step	Description
1	Mobile Node (MN) secures a traffic channel over the airlink with the RAN through the BSC/PCF.
2	The PCF and PDSN/FA establish the R-P interface for the session.
3	The PDSN/FA and MN negotiate Link Control Protocol (LCP).

Step	Description
4	Upon successful LCP negotiation, the MN sends a PPP Authentication Request message to the PDSN/FA.
5	The PDSN/FA sends an Access Request message to the RADIUS AAA server.
6	The RADIUS AAA server successfully authenticates the subscriber and returns an Access Accept message to the PDSN/FA. The Accept message may contain various attributes to be assigned to the MN including the IP address of the HA to use.
7	The PDSN/FA sends a PPP Authentication Response message to the MN.
8	The MN sends an Internet Protocol Control Protocol (IPCP) Configuration Request message to the PDSN/FA with an MN address of 0.0.0.0.
9	The PDSN/FA forwards a Proxy Mobile IP Registration Request message to the HA. The message includes fields such as a Home Address indicator of 0.0.0.0, the IP address of the FA (the care-of-address), the IP address of the FA (the care-of-address), and the FA-HA extension (security parameter index (SPI)).
10	While the FA is communicating with the HA, the MN may send additional IPCP Configuration Request messages.
11	The HA responds with a Proxy Mobile IP Registration Response. The response includes an IP address from one of its locally configured pools to assign to the MN (its Home Address). The HA also creates a mobile binding record (MBR) for the subscriber session.
12	The MN and the PDSN/FA negotiate IPCP. The result is that the MN is assigned the home address originally specified by the AAA server.
13	While the MN and PDSN/FA are negotiating IPCP, the HA and AAA server initiate accounting.
14	Upon completion of the IPCP negotiation, the PDSN/FA and AAA server initiate accounting fully establishing the session allowing the MN to send/receive data to/from the PDN.
15	Upon completion of the session, the MN sends an LCP Terminate Request message to the PDSN to end the PPP session.

Step	Description
16	The PDSN/FA sends a Proxy Mobile IP De-registration Request message to the HA.
17	The PDSN/FA send an LCP Terminate Acknowledge message to the MN ending the PPP session.
18	The HA sends a Proxy Mobile IP De-Registration Response message to the FA terminating the Pi interface
19	The PDSN/FA and the PCF terminate the R-P session.
20	The HA and the AAA server stop accounting for the session.
21	The PDSN and the AAA server stop accounting for the session.

How Proxy Mobile IP Works in 3GPP Network

This section contains call flows displaying successful Proxy Mobile IP session setup scenarios in 3GPP network.

The following figure and the text that follows describe a a sample successful Proxy Mobile IP session setup call flow in 3GPP service.

Figure 51: Proxy Mobile IP Call Flow in 3GPP

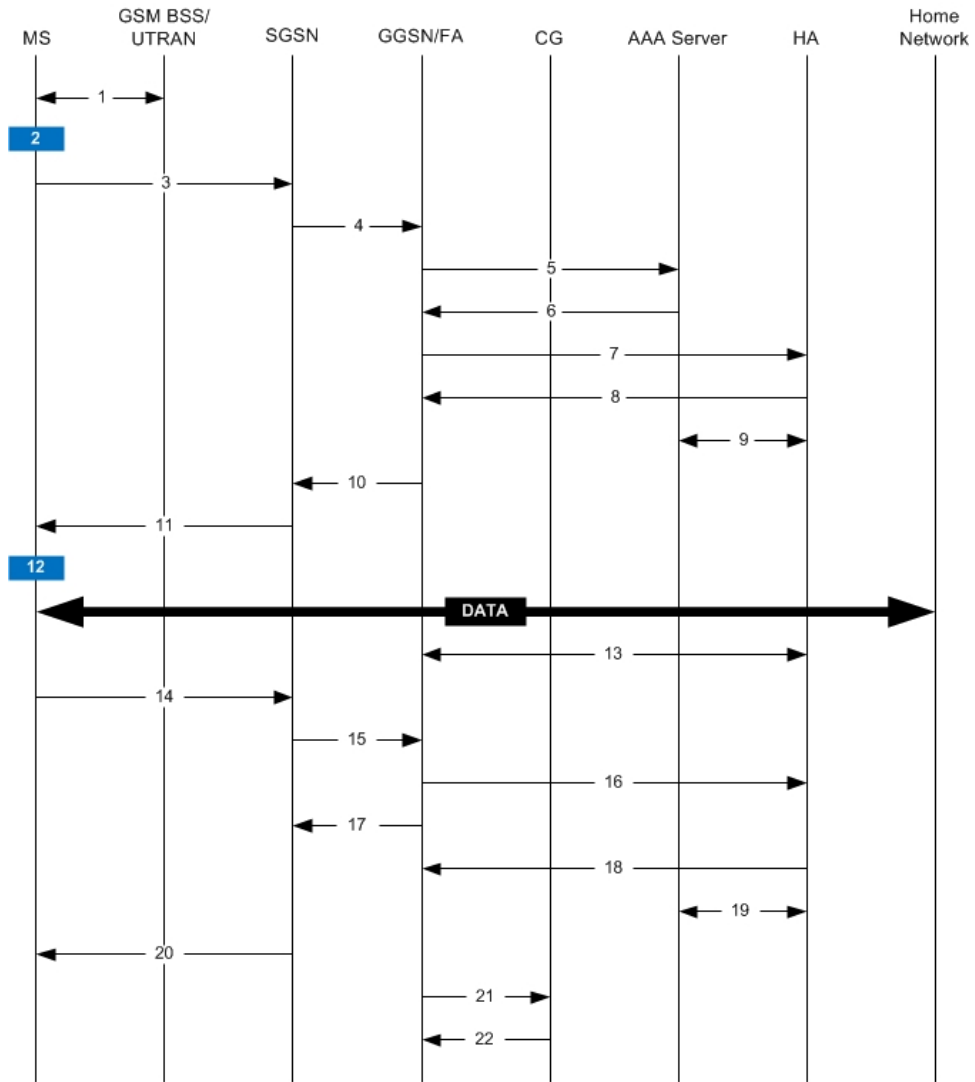

335165

Table 50: Proxy Mobile IP Call Flow in 3GPP Description

Step	Description
1	The mobile station (MS) goes through the process of attaching itself to the GPRS/UMTS network.

Step	Description
2	<p>The terminal equipment (TE) aspect of the MS sends AT commands to the mobile terminal (MT) aspect of the MS to place it into PPP mode.</p> <p>The Link Control Protocol (LCP is then used to configure the Maximum-Receive Unit size and the authentication protocol (Challenge-Handshake Authentication Protocol (CHAP), Password Authentication Protocol (PAP), or none). If CHAP or PAP is used, the TE will authenticate itself to the MT, which, in turn, stores the authentication information.</p> <p>Upon successful authentication, the TE sends an Internet Protocol Control Protocol (IPCP) Configure-Request message to the MT. The message will either contain a static IP address to use or request that one be dynamically assigned.</p>
3	<p>The MS sends an Activate PDP Context Request message that is received by an SGSN. The message contains information about the subscriber such as the Network layer Service Access Point Identifier (NSAPI), PDP Type, PDP Address, Access Point Name (APN), quality of service (QoS) requested, and PDP configuration options.</p>
4	<p>The SGSN authenticates the request message and sends a Create PDP Context Request message to a GGSN using the GPRS Tunneling Protocol (GTPC, "C" indicates the control signalling aspect of the protocol). The recipient GGSN is selected based on either the request of the MS or is automatically selected by the SGSN. The message consists of various information elements including: PDP Type, PDP Address, APN, charging characteristics, and tunnel endpoint identifier (TEID, if the PDP Address was static).</p>

Step	Description
5	<p>The GGSN determines if it can facilitate the session (in terms of memory or CPU resources, configuration, etc.) and creates a new entry in its PDP context list and provides a Charging ID for the session.</p> <p>From the APN specified in the message, the GGSN determines whether or not the subscriber is to be authenticated, if Proxy Mobile IP is to be supported for the subscriber, and if so, the IP address of the HA to contact.</p> <p>Note that Proxy Mobile IP support can also be determined by attributes in the user's profile. Attributes in the user's profile supersede APN settings.</p> <p>If authentication is required, the GGSN attempts to authenticate the subscriber locally against profiles stored in memory or send a RADIUS Access-Request message to a AAA server.</p>
6	<p>If the GGSN authenticated the subscriber to a AAA server, the AAA server responds with a RADIUS Access-Accept message indicating successful authentication and any attributes for handling the subscriber PDP context.</p>
7	<p>If Proxy Mobile IP support was either enabled in the APN or in the subscriber's profile, the GGSN/FA forwards a Proxy Mobile IP Registration Request message to the specified HA. The message includes such things as the MS's home address, the IP address of the FA (the care-of-address), and the FA-HA extension (security parameter index (SPI)).</p>
8	<p>The HA responds with a Proxy Mobile IP Registration Response. The response includes an IP address from one of its locally configured pools to assign to the MS (its Home Address). The HA also creates a mobile binding record (MBR) for the subscriber session.</p>
9	<p>The HA sends an RADIUS Accounting Start request to the AAA server which the AAA server responds to.</p>
10	<p>The GGSN replies with an affirmative Create PDP Context Response using GTPC. The response will contain information elements such as the PDP Address representing either the static address requested by the MS or the address assigned by the GGSN, the TEID used to reference PDP Address, and PDP configuration options specified by the GGSN.</p>

Step	Description
11	The SGSN returns an Activate PDP Context Accept message to the MS. The message includes response to the configuration parameters sent in the initial request.
12	The MT, will respond to the TE's IPCP Config-request with an IPCP Config-Ack message. The MS can now send and receive data to or from the PDN until the session is closed or times out. Note that for Mobile IP, only one PDP context is supported for the MS.
13	The FA periodically sends Proxy Mobile IP Registration Request Renewal messages to the HA. The HA sends responses for each request.
14	The MS can terminate the data session at any time. To terminate the session, the MS sends a Deactivate PDP Context Request message that is received by the SGSN.
15	The SGSN sends a Delete PDP Context Request message to the GGSN facilitating the data session. The message includes the information elements necessary to identify the PDP context (i.e., TEID, and NSAPI).
16	The GGSN removes the PDP context from memory and the FA sends a Proxy Mobile IP Deregistration Request message to the HA.
17	The GGSN returns a Delete PDP Context Response message to the SGSN.
18	The HA replies to the FA with a Proxy Mobile IP Deregistration Request Response.
19	The HA sends an RADIUS Accounting Stop request to the AAA server which the AAA server responds to.
20	The SGSN returns a Deactivate PDP Context Accept message to the MS.
21	The GGSN delivers the GGSN Charging Detail Records (G-CDRs) to a charging gateway (CG) using GTP Prime (GTPP). Note that, though not shown in this example, the GGSN could optionally be configured to send partial CDRs while the PDP context is active.

Step	Description
22	For each accounting message received from the GGSN, the CG responds with an acknowledgement.

How Proxy Mobile IP Works in WiMAX Network

This section contains call flows displaying successful Proxy Mobile IP session setup scenarios. There are multiple scenarios that are dependant on how the MN receives an IP address. The following scenarios are described:

- **Scenario 1:** The AAA server that authenticates the MN at the ASN GW allocates an IP address to the MN. Note that the ASN GW does not allocate an address from its IP pools.
- **Scenario 2:** The HA assigns an IP address to the MN from one of its locally configured dynamic pools.

Scenario 1: AAA server and ASN GW/FA Allocate IP Address

The following figure and table display and describe a call flow in which the MN receives its IP address from the AAA server and ASN GW/FA.

Figure 52: AAA/ASN GW Assigned IP Address Proxy Mobile IP Call Flow

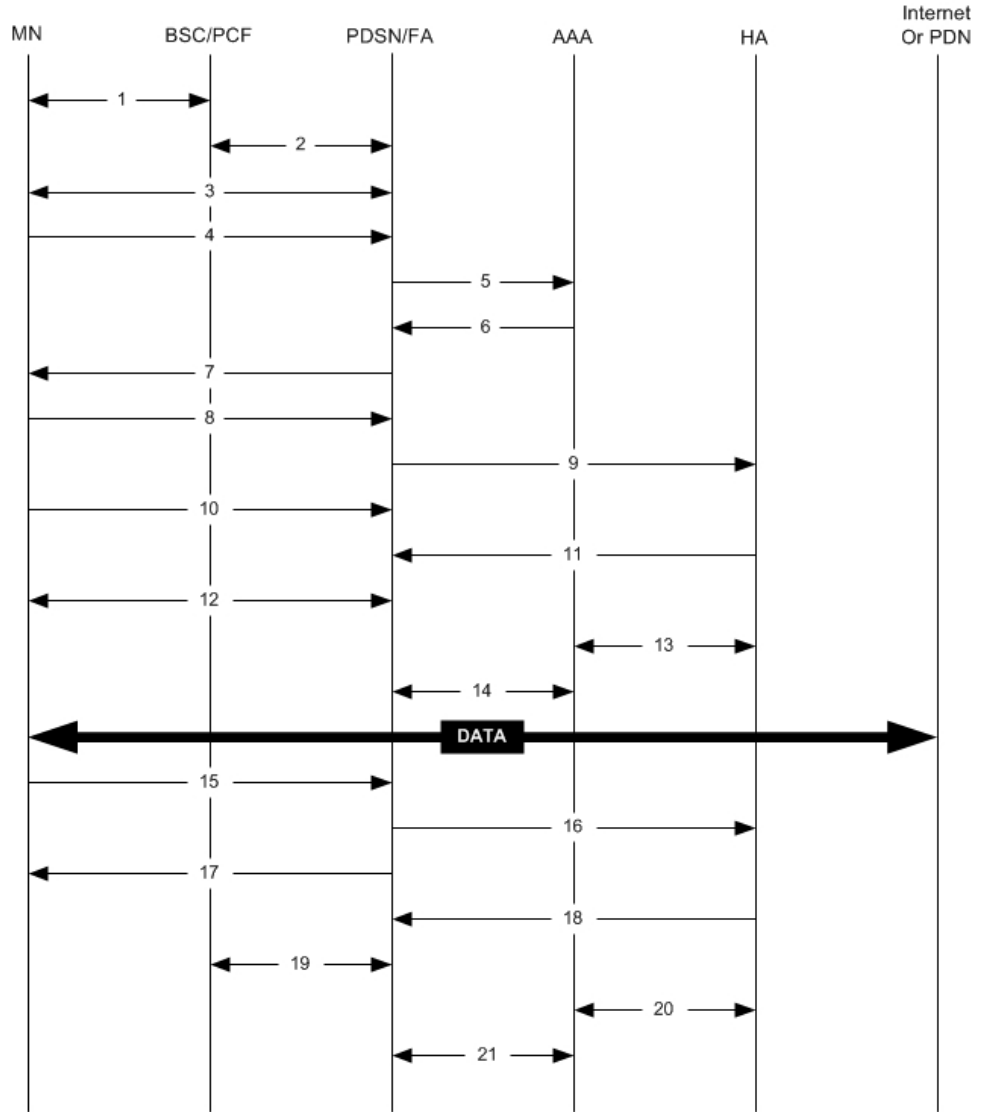

335164

Table 51: AAA/ASN GW Assigned IP Address Proxy Mobile IP Call Flow Description

Step	Description
1	Mobile Node (MN) secures a traffic channel over the airlink with the BS.
2	The BS and ASN GW/FA establish the R6 interface for the session.
3	The ASN GW/FA and MN negotiate Link Control Protocol (LCP).

Step	Description
4	Upon successful LCP negotiation, the MN sends a PPP Authentication Request message to the ASN GW/FA.
5	The ASN GW/FA sends an Access Request message to the RADIUS AAA server.
6	The RADIUS AAA server successfully authenticates the subscriber and returns an Access Accept message to the ASN GW/FA. The Accept message may contain various attributes to be assigned to the MN including the MN's Home Address (IP address) and the IP address of the HA to use.
7	The ASN GW/FA sends a EAP Authentication Response message to the MN.
8	The MN sends an Internet Protocol Control Protocol (IPCP) Configuration Request message to the ASN GW/FA with an MN address of 0.0.0.0.
9	The ASN GW/FA forwards a Proxy Mobile IP Registration Request message to the HA. The message includes fields such as the MN's home address, the IP address of the FA (the care-of-address), and the FA-HA extension (security parameter index (SPI)).
10	While the FA is communicating with the HA, the MN may send additional IPCP Configuration Request messages.
11	The HA responds with a Proxy Mobile IP Registration Response after validating the home address against its pool. The HA also creates a mobile binding record (MBR) for the subscriber session.
12	The MN and the ASN GW/FA negotiate IPCP. The result is that the MN is assigned the home address originally specified by the AAA server.
13	While the MN and ASN GW/FA are negotiating IPCP, the HA and AAA server initiate accounting.
14	Upon completion of the IPCP negotiation, the ASN GW/FA and AAA server initiate accounting fully establishing the session allowing the MN to send/receive data to/from the PDN.
15	Upon completion of the session, the MN sends an LCP Terminate Request message to the ASN GW to end the subscriber session.

Step	Description
16	The PDSN/FA sends a Proxy Mobile IP De-registration Request message to the HA.
17	The ASN GW/FA send an LCP Terminate Acknowledge message to the MN ending the subscriber session.
18	The HA sends a Proxy Mobile IP De-Registration Response message to the FA terminating the R3 interface
19	The ASN GW/FA and the BS terminate the R6 session.
20	The HA and the AAA server stop accounting for the session.
21	The ASN GW and the AAA server stop accounting for the session.

Scenario 2: HA Allocates IP Address

The following figure and table display and describe a call flow in which the MN receives its IP address from the HA.

Figure 53: HA Assigned IP Address Proxy Mobile IP Call Flow

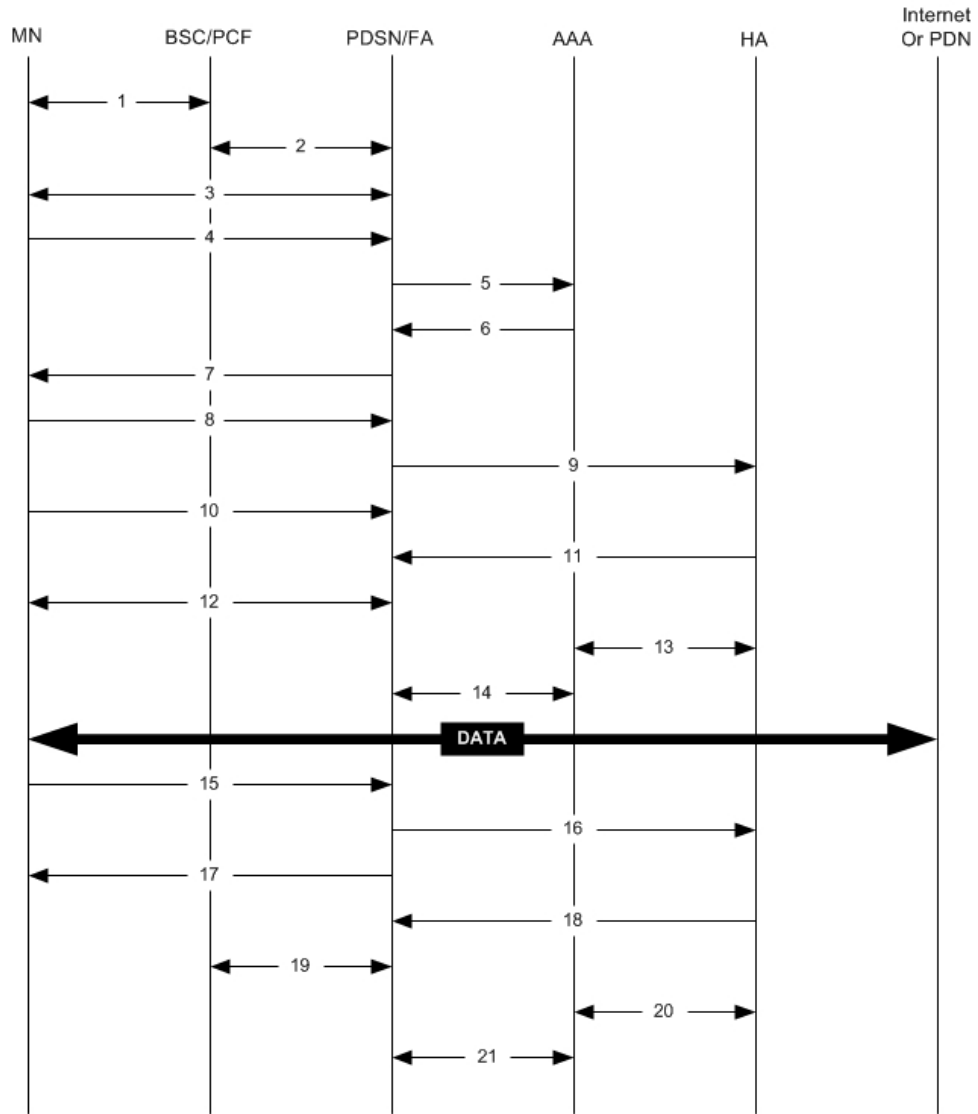

335164

Table 52: HA Assigned IP Address Proxy Mobile IP Call Flow Description

Step	Description
1	Mobile Node (MN) secures a traffic channel over the airlink with the BS.
2	The BS and ASN GW/FA establish the R6 interface for the session.
3	The ASN GW/FA and MN negotiate Link Control Protocol (LCP).

Step	Description
4	Upon successful LCP negotiation, the MN sends an EAP Authentication Request message to the ASN GW/FA.
5	The ASN GW/FA sends an Access Request message to the RADIUS AAA server.
6	The RADIUS AAA server successfully authenticates the subscriber and returns an Access Accept message to the ASN GW/FA. The Accept message may contain various attributes to be assigned to the MN including the IP address of the HA to use.
7	The ASN GW/FA sends an EAP Authentication Response message to the MN.
8	The MN sends an Internet Protocol Control Protocol (IPCP) Configuration Request message to the ASN GW/FA with an MN address of 0.0.0.0.
9	The ASN GW/FA forwards a Proxy Mobile IP Registration Request message to the HA. The message includes fields such as a Home Address indicator of 0.0.0.0, the IP address of the FA (the care-of-address), the IP address of the FA (the care-of-address), and the FA-HA extension (security parameter index (SPI)).
10	While the FA is communicating with the HA, the MN may send additional IPCP Configuration Request messages.
11	The HA responds with a Proxy Mobile IP Registration Response. The response includes an IP address from one of its locally configured pools to assign to the MN (its Home Address). The HA also creates a mobile binding record (MBR) for the subscriber session.
12	The MN and the ASN GW/FA negotiate IPCP. The result is that the MN is assigned the home address originally specified by the AAA server.
13	While the MN and ASN GW/FA are negotiating IPCP, the HA and AAA server initiate accounting.
14	Upon completion of the IPCP negotiation, the ASN GW/FA and AAA server initiate accounting fully establishing the session allowing the MN to send/receive data to/from the PDN.
15	Upon completion of the session, the MN sends an LCP Terminate Request message to the ASN GW to end the subscriber session.

Step	Description
16	The ASN GW/FA sends a Proxy Mobile IP De-registration Request message to the HA.
17	The ASN GW/FA send an LCP Terminate Acknowledge message to the MN ending the PPP session.
18	The HA sends a Proxy Mobile IP De-Registration Response message to the FA terminating the R3 interface
19	The ASN GW/FA and the BS terminate the R6 session.
20	The HA and the AAA server stop accounting for the session.
21	The ASN GW and the AAA server stop accounting for the session.

How Proxy Mobile IP Works in a WiFi Network with Multiple Authentication

Proxy-Mobile IP was developed as a result of networks of Mobile Subscribers (MS) that are not capable of Mobile IP operation. In this scenario a PDIF acts a mobile IP client and thus implements Proxy-MIP support.

Although not required or necessary in a Proxy-MIP network, this implementation uses a technique called Multiple Authentication. In Multi-Auth arrangements, the device is authenticated first using HSS servers. Once the device is authenticated, then the subscriber is authenticated over a RADIUS interface to AAA servers. This supports existing EV-DO servers in the network.

The MS first tries to establish an IKEv2 session with the PDIF. The MS uses the EAP-AKA authentication method for the initial device authentication using Diameter over SCTP over IPv6 to communicate with HSS servers. After the initial Diameter EAP authentication, the MS continues with EAP MD5/GTC authentication.

After successful device authentication, PDIF then uses RADIUS to communicate with AAA servers for the subscriber authentication. It is assumed that RADIUS AAA servers do not use EAP methods and hence RADIUS messages do not contain any EAP attributes.

Assuming a successful RADIUS authentication, PDIF then sets up the IPsec Child SA tunnel using a Tunnel Inner Address (TIA) for passing control traffic only. PDIF receives the MS address from the Home Agent, and passes it on to the MS through the final AUTH response in the IKEv2 exchange.

When IPsec negotiation finishes, the PDIF assigns a home address to the MS and establishes a CHILD SA to pass data. The initial TIA tunnel is torn down and the IP address returned to the address pool. The PDIF then generates a RADIUS accounting START message.

When the session is disconnected, the PDIF generates a RADIUS accounting STOP message.

The following figures describe a Proxy-MIP session setup using CHAP authentication (EAP-MD5), but also addresses a PAP authentication setup using EAP-GTC when EAP-MD5 is not supported by either PDIF or MS.

Figure 54: Proxy-MIP Call Setup using CHAP Authentication

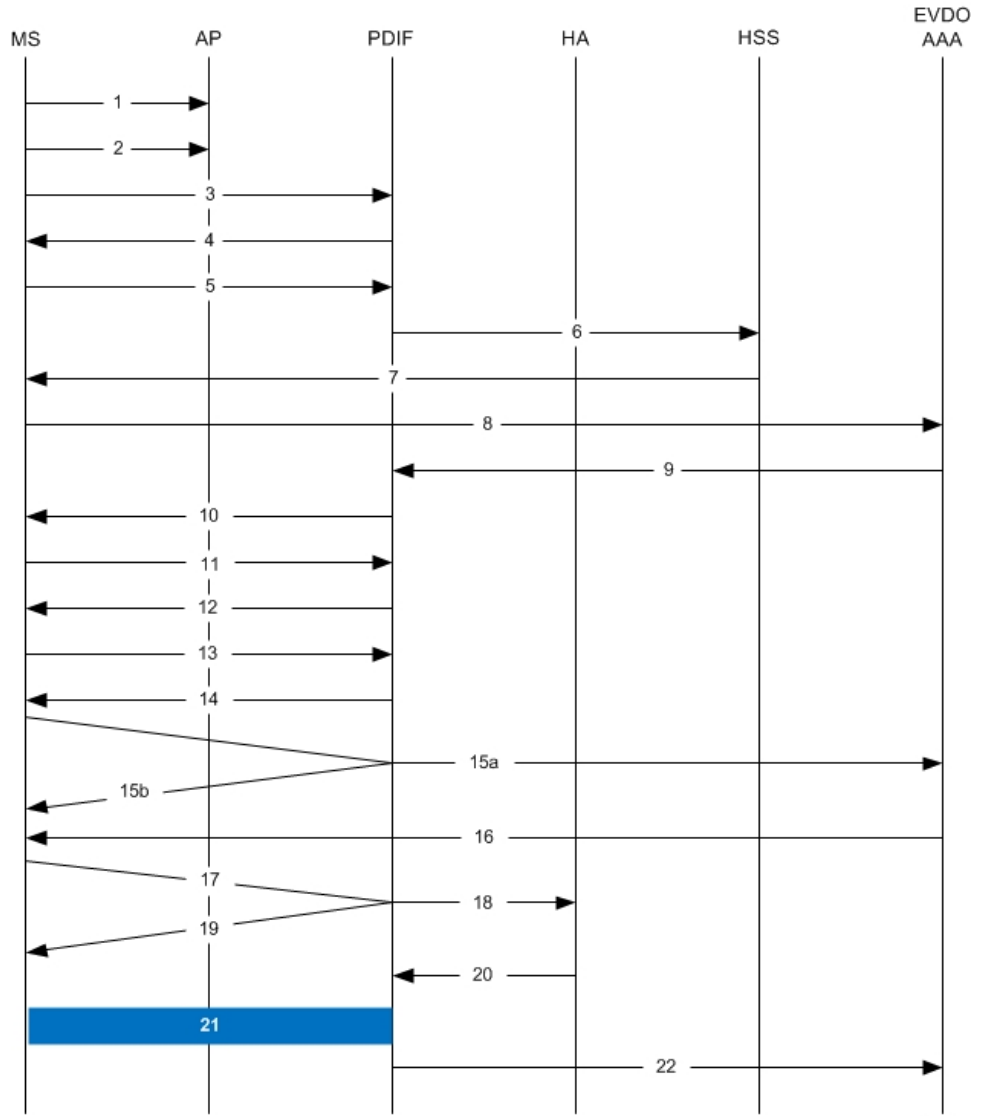

335166

Table 53: Proxy-MIP Call Setup using CHAP Authentication

Step	Description
1	On connecting to WiFi network, MS first send DNS query to get PDIF IP address
2	MS receives PDIF address from DNS

Step	Description
3	MS sets up IKEv2/IPSec tunnel by sending IKE_SA_INIT Request to PDIF. MS includes SA, KE, Ni, NAT-DETECTION Notify payloads in the IKEv2 exchange.
4	PDIF processes the IKE_SA_INIT Request for the appropriate PDIF service (bound by the destination IP address in the IKEv2 INIT request). PDIF responds with IKE_SA_INIT Response with SA, KE, Nr payloads and NAT-Detection Notify payloads. If multiple-authentication support is configured to be enabled in the PDIF service, PDIF will include MULTIPLE_AUTH_SUPPORTED Notify payload in the IKE_SA_INIT Response. PDIF will start the IKEv2 setup timer after sending the IKE_SA_INIT Response.
5	On receiving successful IKE_SA_INIT Response from PDIF, MS sends IKE_AUTH Request for the first EAP-AKA authentication. If the MS is capable of doing multiple-authentication, it will include MULTI_AUTH_SUPPORTED Notify payload in the IKE_AUTH Request. MS also includes IDi payload which contains the NAI, SA, TSi, TSr, CP (requesting IP address and DNS address) payloads. MS will not include AUTH payload to indicate that it will use EAP methods.
6	On receiving IKE_AUTH Request from MS, PDIF sends DER message to Diameter AAA server. AAA servers are selected based on domain profile, default subscriber template or default domain configurations. PDIF includes Multiple-Auth-Support AVP, EAP-Payload AVP with EAP-Response/Identity in the DER. Exact details are explained in the Diameter message sections. PDIF starts the session setup timer on receiving IKE_AUTH Request from MS.
7	PDIF receives DEA with Result-Code AVP specifying to continue EAP authentication. PDIF takes EAP-Payload AVP contents and sends IKE_AUTH Response back to MS in the EAP payload. PDIF allows IDr and CERT configurations in the PDIF service and optionally includes IDr and CERT payloads (depending upon the configuration). PDIF optionally includes AUTH payload in IKE_AUTH Response if PDIF service is configured to do so.

Step	Description
8	MS receives the IKE_AUTH Response from PDIF. MS processes the exchange and sends a new IKE_AUTH Request with EAP payload. PDIF receives the new IKE_AUTH Request from MS and sends DER to AAA server. This DER message contains the EAP-Payload AVP with EAP-AKA challenge response and challenge received from MS.
9	The AAA server sends the DEA back to the PDIF with Result-Code AVP as "success." The EAP-Payload AVP message also contains the EAP result code with "success." The DEA also contains the IMSI for the user, which is included in the Callback-Id AVP. PDIF uses this IMSI for all subsequent session management functions such as duplicate session detection etc. PDIF also receives the MSK from AAA, which is used for further key computation.
10	PDIF sends the IKE_AUTH Response back to MS with the EAP payload.
11	MS sends the final IKE_AUTH Request for the first authentication with the AUTH payload computed from the keys. If the MS plans to do the second authentication, it will include ANOTHER_AUTH_FOLLOWS Notify payload also.

Step	Description
12	<p>PDIF processes the AUTH request and responds with the IKE_AUTH Response with the AUTH payload computed from the MSK. PDIF does not assign any IP address for the MS pending second authentication. Nor will the PDIF include any configuration payloads.</p> <p>a. If PDIF service does not support Multiple-Authentication and ANOTHER_AUTH_FOLLOWS Notify payload is received, then PDIF sends IKE_AUTH Response with appropriate error and terminate the IKEv2 session by sending INFORMATIONAL (Delete) Request. b. If ANOTHER_AUTH_FOLLOWS Notify payload is not present in the IKE_AUTH Request, PDIF allocates the IP address from the locally configured pools. However, if proxy-mip-required is enabled, then PDIF initiates Proxy-MIP setup to HA by sending P-MIP RRQ. When PDIF receives the Proxy-MIP RRP, it takes the Home Address (and DNS addresses if any) and sends the IKE_AUTH Response back to MS by including CP payload with Home Address and DNS addresses. In either case, IKEv2 setup will finish at this stage and IPsec tunnel gets established with a Tunnel Inner Address (TIA).</p>
13	<p>MS does the second authentication by sending the IKE_AUTH Request with IDi payload to include the NAI. This NAI may be completely different from the NAI used in the first authentication.</p>

Step	Description
14	<p>On receiving the second authentication IKE_AUTH Request, PDIF checks the configured second authentication methods. The second authentication may be either EAP-MD5 (default) or EAP-GTC. The EAP methods may be either EAP-Passthru or EAP-Terminated.</p> <p>a. If the configured method is EAP-MD5, PDIF sends the IKE_AUTH Response with EAP payload including challenge. b. If the configured method is EAP-GTC, PDIF sends the IKE_AUTH Response with EAP-GTC. c. MS processes the IKE_AUTH Response:</p> <ul style="list-style-type: none"> • If the MS supports EAP-MD5, and the received method is EAP-MD5, then the MS will take the challenge, compute the response and send IKE_AUTH Request with EAP payload including Challenge and Response. • If the MS does not support EAP-MD5, but EAP-GTC, and the received method is EAP-MD5, the MS sends legacy-Nak with EAP-GTC.
15(a)	<p>PDIF receives the new IKE_AUTH Request from MS.</p> <p>If the original method was EAP-MD5 and MD5 challenge and response is received, PDIF sends RADIUS Access Request with corresponding attributes (Challenge, Challenge Response, NAI, IMSI etc.).</p>
15(b)	<p>If the original method was EAP-MD5 and legacy-Nak was received with GTC, the PDIF sends IKE_AUTH Response with EAP-GTC.</p>
16	<p>PDIF receives Access Accept from RADIUS and sends IKE_AUTH Response with EAP success.</p>
17	<p>PDIF receives the final IKE_AUTH Request with AUTH payload.</p>
18	<p>PDIF checks the validity of the AUTH payload and initiates Proxy-MIP setup request to the Home Agent if proxy-mip-required is enabled. The HA address may be received from the RADIUS server in the Access Accept (Step 16) or may be locally configured. PDIF may also remember the HA address from the first authentication received in the final DEA message.</p>

Step	Description
19	If proxy-mip-required is disabled, PDIF assigns the IP address from the local pool.
20	PDIF received proxy-MIP RRP and gets the IP address and DNS addresses.
21	PDIF sets up the IPSec tunnel with the home address. On receiving the IKE_AUTH Response MS also sets up the IPSec tunnel using the received IP address. PDIF sends the IKE_AUTH Response back to MS by including the CP payload with the IP address and optionally the DNS addresses. This completes the setup.
22	PDIF sends a RADIUS Accounting start message.



Important

For Proxy-MIP call setup using PAP, the first 14 steps are the same as for CHAP authentication. However, here they deviate because the MS does not support EAP-MD5 authentication, but EAP-GTC. In response to the EAP-MD5 challenge, the MS instead responds with legacy-Nak with EAP-GTC. The diagram below picks up at this point.

Figure 55: Proxy-MIP Call Setup using PAP Authentication

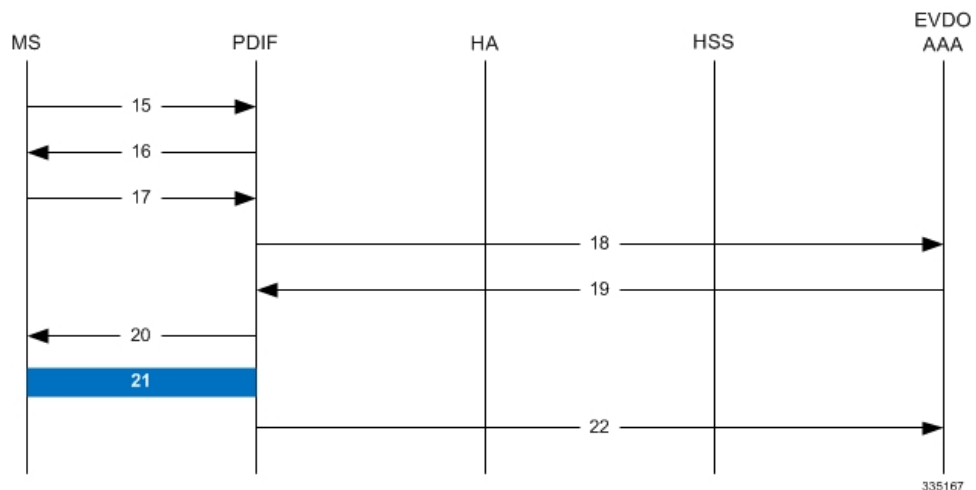

Table 54: Proxy-MIP Call Setup using PAP Authentication

Step	Description
15	MS is not capable of CHAP authentication but PAP authentication, and the MS returns the EAP payload to indicate that it needs EAP-GTC authentication.

Step	Description
16	PDIF then initiates EAP-GTC procedure, and requests a password from MS.
17	MS includes an authentication password in the EAP payload to PDIF.
18	Upon receipt of the password, PDIF sends a RADIUS Access Request which includes NAI in the User-Name attribute and PAP-password.
19	Upon successful authentication, the AAA server returns a RADIUS Access Accept message, which may include Framed-IP-Address attribute.
20	The attribute content in the Access Accept message is encoded as EAP payload with EAP success when PDIF sends the IKE_AUTH Response to the MS.
21	The MS and PDIF now have a secure IPSec tunnel for communication.
22	Pdif sends an Accounting START message.

Configuring Proxy Mobile-IP Support

Support for Proxy Mobile-IP requires that the following configurations be made:



Important

Not all commands and keywords/variables may be supported. This depends on the platform type and the installed license(s).

- **FA service(s):** Proxy Mobile IP must be enabled, operation parameters must be configured, and FA-HA security associations must be specified.
- **HA service(s):** FA-HA security associations must be specified.
- **Subscriber profile(s):** Attributes must be configured to allow the subscriber(s) to use Proxy Mobile IP. These attributes can be configured in subscriber profiles stored locally on the system or remotely on a RADIUS AAA server.
- **APN template(s):** Proxy Mobile IP can be supported for every subscriber IP PDP context facilitated by a specific APN template based on the configuration of the APN.



Important

These instructions assume that the system was previously configured to support subscriber data sessions as a core network service and/or an HA according to the instructions described in the respective product administration guide.

Configuring FA Services

Use this example to configure an FA service to support Proxy Mobile IP:

```
configure
context <context_name>
fa-service <fa_service_name>
proxy-mip allow
proxy-mip max-retransmissions <integer>
proxy-mip retransmission-timeout <seconds>
proxy-mip renew-percent-time percentage
fa-ha-spi remote-address { ha_ip_address | ip_addr_mask_combo } spi-number number
{ encrypted secret enc_secret | secret secret } [ description string ] [
hash-algorithm { hmac-md5 | md5 | rfc2002-md5 } | replay-protection {
timestamp | nonce } | timestamp-tolerance tolerance ]
authentication mn-ha allow-noauth
end
```

Notes:

- The **proxy-mip max-retransmissions** command configures the maximum number re-try attempts that the FA service is allowed to make when sending Proxy Mobile IP Registration Requests to the HA.
- **proxy-mip retransmission-timeout** configures the maximum amount of time allowed by the FA for a response from the HA before re-sending a Proxy Mobile IP Registration Request message.
- **proxy-mip renew-percent-time** configures the amount of time that must pass prior to the FA sending a Proxy Mobile IP Registration Renewal Request.

Example

If the advertisement registration lifetime configured for the FA service is 900 seconds and the renew-time is configured to 50, then the FA requests a lifetime of 900 seconds in the Proxy MIP registration request. If the HA grants a lifetime of **600** seconds, then the FA sends the Proxy Mobile IP Registration Renewal Request message after **300** seconds have passed.

- Use the **fa-ha-spi remote-address** command to modify configured FA-HA SPIs to support Proxy Mobile IP. Refer to the *Command Line Interface Reference* for the full command syntax.



Important Note that FA-HA SPIs **must** be configured for the Proxy-MIP feature to work, while it is optional for regular MIP.

- Use the **authentication mn-ha allow-noauth** command to configure the FA service to allow communications from the HA without authenticating the HA.

Verify the FA Service Configuration

Use the following command to verify the configuration of the FA service:

```
show fa-service name <fa_service_name>
```

Notes:

- Repeat this example as needed to configure additional FA services to support Proxy-MIP.
- Save your configuration to flash memory, an external memory device, and/or a network location using the Exec mode command **save configuration**. For additional information on how to verify and save configuration files, refer to the *System Administration Guide* and the *Command Line Interface Reference*.

Proceed to the optional [Configuring Proxy MIP HA Failover, on page 497](#) to configure Proxy MIP HA Failover support or skip to the *Configuring HA Services* to configure HA service support for Proxy Mobile IP.

Configuring Proxy MIP HA Failover

Use this example to configure Proxy Mobile IP HA Failover:



Important

This configuration in this section is optional.

When configured, Proxy MIP HA Failover provides a mechanism to use a specified alternate Home Agent for the subscriber session when the primary HA is not available. Use the following configuration example to configure the Proxy MIP HA Failover:

```
configure
context <context_name>
fa-service <fa_service_name>
proxy-mip ha-failover [ max-attempts <max_attempts> |
num-attempts-before-switching <num_attempts> | timeout <seconds> ]
```

Notes:

- Save your configuration to flash memory, an external memory device, and/or a network location using the Exec mode command **save configuration**. For additional information on how to verify and save configuration files, refer to the *System Administration Guide* and the *Command Line Interface Reference*.

Configuring Subscriber Profile RADIUS Attributes

In order for subscribers to use Proxy Mobile IP, attributes must be configured in their user profile or in an APN for 3GPP service. As mentioned previously, the subscriber profiles can be located either locally on the system or remotely on a RADIUS AAA server.

This section provides information on the RADIUS attributes that must be used and instructions for configuring locally stored profiles/APNs in support of Proxy Mobile IP.



Important

Instructions for configuring RADIUS-based subscriber profiles are not provided in this document. Please refer to the documentation supplied with your server for further information.

Configuring Subscriber Profile RADIUS Attributes

In order for subscribers to use Proxy Mobile IP, attributes must be configured in their user profile or in an APN for 3GPP service. As mentioned previously, the subscriber profiles can be located either locally on the system or remotely on a RADIUS AAA server.

This section provides information on the RADIUS attributes that must be used and instructions for configuring locally stored profiles/APNs in support of Proxy Mobile IP.



Important

Instructions for configuring RADIUS-based subscriber profiles are not provided in this document. Please refer to the documentation supplied with your server for further information.

RADIUS Attributes Required for Proxy Mobile IP

The following table describes the attributes that must be configured in profiles stored on RADIUS AAA servers in order for the subscriber to use Proxy Mobile IP.

Table 55: Required RADIUS Attributes for Proxy Mobile IP

Attribute	Description	Values
SN-Subscriber- Permission OR SN1-Subscriber- Permission	Indicates the services allowed to be delivered to the subscriber. For Proxy Mobile IP, this attribute must be set to Simple IP.	<ul style="list-style-type: none"> • None (0) • Simple IP (0x01) • Mobile IP (0x02) • Home Agent Terminated Mobile IP (0x04)
SN-Proxy-MIP OR SN1-Proxy-MIP	Specifies if the configured service will perform compulsory Proxy-MIP tunneling for a Simple-IP subscriber. This attribute must be enabled to support Proxy Mobile IP.	<ul style="list-style-type: none"> • Disabled - do not perform compulsory Proxy-MIP (0) • Enabled - perform compulsory Proxy-MIP (1)
SN-Simultaneous- SIP-MIP OR SN1-Simultaneous- SIP-MIP	Indicates whether or not a subscriber can simultaneously access both Simple IP and Mobile IP services. Note Regardless of the configuration of this attribute, the FA facilitating the Proxy Mobile IP session will not allow simultaneous Simple IP and Mobile IP sessions for the MN.	<ul style="list-style-type: none"> • Disabled (0) • Enabled (1)

Attribute	Description	Values
SN-PDSN-Handoff- Req-IP-Addr OR SN1-PDSN-Handoff- Req-IP-Addr	<p>Specifies whether or not the system should reject and terminate the subscriber session when the proposed address in IPCP by the mobile does not match the existing address that was granted by the chassis during an Inter-chassis handoff.</p> <p>This can be used to disable the acceptance of 0.0.0.0 as the IP address proposed by the MN during the IPCP negotiation that occurs during an Inter-chassis handoff.</p> <p>This attribute is disabled (do not reject) by default.</p>	<ul style="list-style-type: none"> • Disabled - do not reject (0) • Enabled - reject (1)
3GPP2-MIP-HA-Address	<p>This attribute sent in an Access-Accept message specifies the IP Address of the HA.</p> <p>Multiple attributes can be sent in Access Accept. However, only the first two are considered for processing. The first one is the primary HA and the second one is the secondary (alternate) HA used for HA Failover.</p>	IPv4 Address

Configuring Local Subscriber Profiles for Proxy-MIP on a PDSN

This section provides information and instructions for configuring local subscriber profiles on the system to support Proxy Mobile IP on a PDSN.

configure

```

context <context_name>
subscriber name <subscriber_name>
permission pdsn-simple-ip
proxy-mip allow
inter-pdsn-handoff require ip-address
mobile-ip home-agent <ha_address>
<optional> mobile-ip home-agent <ha_address> alternate
ip context-name <context_name>
end

```

Verify that your settings for the subscriber(s) just configured are correct.

```
show subscribers configuration username <subscriber_name>
```

Notes:

- Configure the system to enforce the MN's use of its assigned IP address during IPCP negotiations resulting from inter-PDSN handoffs. Sessions re-negotiating IPCP will be rejected if they contain an address other than that which was granted by the PDSN (i.e. 0.0.0.0). This rule can be enabled by entering the **inter-pdsn-handoff require ip-address** command.
- Optional: If you have enabled the Proxy-MIP HA Failover feature, use the **mobile-ip home-agent ha_address** alternate command to specify the secondary, or alternate HA.
- Repeat this example as needed to configure additional FA services to support Proxy-MIP.
- Save your configuration to flash memory, an external memory device, and/or a network location using the Exec mode command **save configuration**. For additional information on how to verify and save configuration files, refer to the *System Administration Guide* and the *Command Line Interface Reference*.

Configuring Local Subscriber Profiles for Proxy-MIP on a PDIF

This section provides instructions for configuring local subscriber profiles on the system to support Proxy Mobile IP on a PDIF.

```
configure
context <context-name>
subscriber name <subscriber_name>
proxy-mip require
```

Note

subscriber_name is the name of the subscriber and can be from 1 to 127 alpha and/or numeric characters and is case sensitive.

Configuring Default Subscriber Parameters in Home Agent Context

It is very important that the subscriber default, configured in the same context as the HA service, has the name of the destination context configured. Use the configuration example below:

```
configure
context <context_name>
ip context-name <context_name>
end
```

Save your configuration to flash memory, an external memory device, and/or a network location using the Exec mode command **save configuration**. For additional information on how to verify and save configuration files, refer to the *System Administration Guide* and the *Command Line Interface Reference*.

Configuring APN Parameters

This section provides instructions for configuring the APN templates to support Proxy Mobile IP for all IP PDP contexts they facilitate.



Important

This is an optional configuration. In addition, attributes returned from the subscriber's profile for non-transparent IP PDP contexts take precedence over the configuration of the APN.

These instructions assume that you are at the root prompt for the Exec mode:

```
[local]host_name
```

-
- Step 1** Enter the configuration mode by entering the following command:
- configure**
- The following prompt appears:
- ```
[local]host_name(config)
```
- Step 2** Enter context configuration mode by entering the following command:
- context** <context\_name>
- context\_name* is the name of the system destination context designated for APN configuration. The name must be from 1 to 79 alpha and/or numeric characters and is case sensitive. The following prompt appears:
- ```
[<context_name>]host_name(config-ctx)
```
- Step 3** Enter the configuration mode for the desired APN by entering the following command:
- apn** <apn_name>
- apn_name* is the name of the APN that is being configured. The name must be from 1 to 62 alpha and/or numeric characters and is not case sensitive. It may also contain dots (.) and/or dashes (-). The following prompt appears:
- ```
[<context_name>]host_name(config-apn)
```
- Step 4** Enable proxy Mobile IP for the APN by entering the following command:
- proxy-mip required**
- This command causes proxy Mobile IP to be supported for all IP PDP contexts facilitated by the APN.
- Step 5** *Optional.* GGSN/FA MN-NAI extension can be skipped in MIP Registration Request by entering following command:
- proxy-mip null-username static-homeaddr**
- This command will enable the accepting of MIP Registration Request without NAI extensions in this APN.
- Step 6** Return to the root prompt by entering the following command:
- end**
- The following prompt appears:
- ```
[local]host_name
```
- Step 7** Repeat *step 1* through *step 6* as needed to configure additional APNs.
- Step 8** Verify that your APNs were configured properly by entering the following command:
- show apn { all | name <apn_name> }**
- The output is a detailed listing of configured APN parameter settings.
- Step 9** Save your configuration to flash memory, an external memory device, and/or a network location using the Exec mode command **save configuration**. For additional information on how to verify and save configuration files, refer to the *System Administration Guide* and the *Command Line Interface Reference*.
-



APPENDIX **R**

Rejection/Redirection of HA Sessions on Network Failures

This chapter provides information on configuring an enhanced, or extended, service. The product Administration Guides provide examples and procedures for configuration of basic services on the system. It is recommended that you select the configuration example that best meets your service model, and configure the required elements for that model, as described in the respective product Administration Guide, before using the procedures in this chapter.

This chapter contains the following topics:

- [Overview, on page 503](#)
- [Configuring HA Session Redirection, on page 504](#)
- [RADIUS Attributes, on page 507](#)

Overview

This feature enables the HA service to either reject new calls or redirect them to another HA when a destination network connection failure is detected. When network connectivity is re-established, the HA service begins to accept calls again in the normal manner.

The way this is implemented in the system is as follows:

- A policy is configured in the HA service that tells the service what action to take when network connectivity is lost. New calls are either directed to one of up to 16 different IP addresses or all new calls are rejected until network connectivity is restored.
- In the destination context, a network reachability server is configured. This is a device on the destination network to which ping packets are periodically sent to determine if the network is reachable. As soon as a network reachability server is configured, pinging of the server commences whether or not the server name is bound to a subscriber or an IP pool.
- The name of the network reachability server configured in the destination context is bound to either a local subscriber profile or an IP pool. If the subscriber is authenticated by an AAA server, RADIUS attributes may specify the network reachability server for the subscriber. (If an IP pool has a network reachability server name bound to it, that takes precedence over both the RADIUS attributes and the local subscriber configuration.)

Configuring HA Session Redirection

This section provides instructions for configuring rejection or redirection of HA sessions on the event of a network failure. These instructions assume that there is a destination context, an HA service, an IP pool, and a subscriber already configured and that you are at the root prompt for the Exec mode:

```
[local]host_name
```

Step 1 Enter the global configuration mode by entering the following command:

```
configure
```

The following prompt appears:

```
[local]host_name(config)
```

Step 2 Enter context configuration mode by entering the following command:

```
context <context_name>
```

context_name is the name of the destination context where the HA service is configured. The name must be from 1 to 63 alpha and/or numeric characters and is case sensitive. The following prompt appears:

```
[<context_name>]host_name(config-ctx)
```

Step 3 Enter the HA service configuration mode by entering the following command:

```
ha-service <ha_service_name>
```

ha_service_name is the name of the HA service. The name must be from 1 to 63 alpha and/or numeric characters and is case sensitive. The following prompt appears:

```
[<context_name>]host_name(config-ha-service)
```

Step 4 Configure the action for the HA service to take when network connectivity is lost by entering the following command:

```
policy nw-reachability-fail { reject [ use-reject-code { admin-prohibited | insufficient-resources } ] | redirect <ip_addr1> [ weight <value> ] [ <ip_addr2> [ weight <value> ] ] ... [ <ip_addr16> [ weight <value> ] ] }
```

Keyword/Variable	Description
reject	Upon network reachability failure reject all new calls for this context.
use-reject-code { admin-prohibited insufficient-resources }	When rejecting calls send the specified reject code. If this keyword is not specified the admin-prohibited reject code is sent by default.

Keyword/Variable	Description
<pre>redirect <ip_addr1> [weight <value>] [<ip_addr2> [weight <value>]] ... [<ip_addr16> [weight <value>]]</pre>	<p>Upon network reachability failure redirect all calls to the specified IP address.</p> <p><i><ip_addr></i>: This must be an IPv4 address. Up to 16 IP addresses and optional weight values can be entered on one command line.</p> <p>weight <i><value></i>: When multiple addresses are specified, they are selected in a weighted round-robin scheme. If a weight is not specified, the entry is automatically assigned a weight of 1. <i><value></i> must be an integer from 1 through 10.</p>

Step 5 Enter the following command to return to the context configuration mode:

```
exit
```

The following prompt appears:

```
[<context_name>]host_name (config-ctx)
```

Step 6 Specify the network device on the destination network to which ping packets should be sent to test for network reachability, by entering the following command:

```
nw-reachability server <server_name> [ interval <seconds> ] [ local-addr <ip_addr> ] [
num-retry <num> ] [ remote-addr <ip_addr> ] [ timeout <seconds> ]
```

Keyword/Variable	Description
<i>server_name</i>	A name for the network device that is sent ping packets to test for network reachability.
interval <i><seconds></i>	Default: 60 seconds Specifies the frequency in seconds for sending ping requests. <i><seconds></i> must be an integer from 1 through 3600.
local-addr <i><ip_addr></i>	Specifies the IP address to be used as the source address of the ping packets; If this is unspecified, an arbitrary IP address that is configured in the context is used. <i><ip_addr></i> must be an IP v4 address.
num-retry <i><num></i>	Default: 5 Specifies the number of retries before deciding that there is a network-failure. <i><num></i> must be an integer from 0 through 100.
remote-addr <i><ip_addr></i>	Specifies the IP address of a network element to use as the destination to send the ping packets for detecting network failure or reachability. <i><ip_addr></i> must be an IPv4 address.

Keyword/Variable	Description
timeout < seconds>	Default: 3 seconds Specifies how long to wait, in seconds, before retransmitting a ping request to the remote address. <seconds> must be an integer from 1 through 10.

Step 7 Repeat *step 6* to configure additional network reachability servers.

Step 8 To bind a network reachability server to an IP pool, continue with *step 9*. To bind a network reachability server to a local subscriber profile, skip to *step 11*.

Step 9 To bind a network reachability server name to an IP pool, enter the following command:

```
ip pool <pool_name> nw-reachability server <server_name>
```

<pool_name>	The name of an existing IP pool in the current context.
nw-reachability server <server_name>	Bind the name of a configured network reachability server to the IP pool and enable network reachability detection for the IP pool. This takes precedence over any network reachability server settings in a subscriber configuration or RADIUS attribute. <server_name>: The name of a network reachability server that has been defined in the current context. This is a string of from 1 through 16 characters.

Step 10 Repeat *step 9* for additional IP pools in the current context then skip to *step 13*.

Step 11 Enter the subscriber configuration mode by entering the following command:

```
subscriber { default | name <subs_name> }
```

Where **default** is the default subscriber for the current context and *subs_name* is the name of the subscriber profile that you want to configure for network reachability. The following prompt appears:

```
[<context_name>]host_name (config-subscriber)
```

Step 12 To bind a network reachability server name to the current subscriber in the current context, enter the following command:

```
nw-reachability server <server_name>
```

Where *server_name* is the name of a network reachability server that has been defined in the current context.

Step 13 Return to the executive mode by entering the following command:

```
end
```

The following prompt appears:

```
[local]host_name
```

Step 14 Enter the executive mode for the destination context for which you configured network reachability by entering the following command:

```
context <context_name>
```

Where *context_name* is the name of the destination context for which you configured network reachability. The following prompt appears:

```
[context_name]host_name
```

Step 15 Check the network reachability server configuration by entering the following command

```
show nw-reachability server all
```

The output of this command appears similar to the following:

```

Server          remote-addr    local-addr    state
-----
nw-server1      192.168.100.20 192.168.1.10  Down
Total Network Reachability Servers: 1 Up: 0
```

Ensure that the remote and local addresses are correct. The state column indicates whether or not the server is reachable (Up) or unreachable (Down).

Step 16 Check the HA service policy by entering the following command:

```
show ha-service name <ha_service_name>
```

Where *<ha_service_name>* is the name of the HA service in the current context for which you configured a network reachability policy. The output of this command includes information about the network reachability policy that looks similar to the following:

```
NW-Reachability Policy: Reject (Reject code: Admin Prohibited)
```

Step 17 Check the network reachability server name bound to an IP pool by entering the following command:

```
show ip pool pool-name <pool_name>
```

Where *<pool_name>* is the name of the IP pool to which you bound a network reachability server name. The output of this command includes information about the network reachability server name that looks similar to the following:

```
Network Reachability Detection Server: nw-server1
```

Step 18 Check the network reachability server name bound to a local subscriber profile by entering the following command:

```
show subscribers configuration username <subscriber_name>
```

Where *<subscriber_name>* is the name of the local subscriber to which you bound a network reachability server name. The output of this command includes information about the network reachability server name that looks similar to the following:

```
network reachability detection server name: nw-server1
```

Step 19 Save your configuration to flash memory, an external memory device, and/or a network location using the Exec mode command **save configuration**. For additional information on how to verify and save configuration files, refer to the *System Administration Guide* and the *Command Line Interface Reference*.

RADIUS Attributes

Attributes defined in a subscriber profile stored remotely on a RADIUS server can be used to bind the network reachability server to a subscriber session. Use the following attributes to bind a network reachability server to a subscriber session;

- SN-Nw-Reachability-Server-Name
- SN1-Nw-Reachability-Server-Name

The attributes have one possible value, which is a variable that is a string of from 1 to 15 characters in length. This should be the name of the configured network reachability server.

The **SN-Nw-Reachability-Server-Name** attribute is contained in the following dictionaries:

- starent
- starent-835

The **SN1-Nw-Reachability-Server-Name** attribute is contained in the following dictionaries:

- starent-vs1
- starent-vs1-835

Refer to the *AAA Interface Administration and Reference* for more details.



APPENDIX **S**

Remote Address-based RADIUS Accounting

This chapter provides information on configuring an enhanced, or extended, service. The product administration guides provide examples and procedures for the configuration of basic services on the system. It is recommended that you select the configuration example that best meets your service model, and configure the required elements for that model before using the procedures in this chapter.

This chapter includes the following topics:

- [Overview, on page 509](#)
- [Configuring Remote Address-based Accounting, on page 510](#)
- [Subscriber Attribute Configuration, on page 510](#)

Overview

Remote address-based RADIUS accounting counts the number of octets exchanged between individual subscribers and specific remote IP addresses, or networks, during a packet data session. Data from the subscriber to the remote addresses, and data from the remote addresses to the subscriber are accounted for separately.

The remote addresses for which to collect RADIUS accounting data are configured in lists on a per-context basis. Individual subscribers are associated with particular address lists through the configuration or specification of an attribute in their locally configured or RADIUS server-based profiles. Once the lists and subscriber profiles are configured, accounting data collection can be enabled on the system.

Remote address-based RADIUS accounting is implemented in the system according to the specifications described in TIA/EIA/IS-835-B, CDMA2000 Wireless IP Network Standard, October 2002 and 3GPP2 X.S0011-005-D.

License Requirements

The Remote address-based RADIUS Accounting is a licensed Cisco feature. A separate feature license may be required. Contact your Cisco account representative for detailed information on specific licensing requirements. For information on installing and verifying licenses, refer to the Managing License Keys section of the Software Management Operations chapter in the *System Administration Guide*.

Configuring Remote Address-based Accounting

To configure this functionality, a list of up to ten remote addresses or networks is configured in the authentication context, the list is assigned to a subscriber, and remote address collection is enabled.

Use the following configuration example to configure remote address-based accounting:

```
configure
  context <context_name>
    radius group <group_name>
    radius accounting ip remote-address list <list_id>
    address <ipv4_address/ipv6_address> netmask <netmask>
  end
```

Verifying the Remote Address Lists

Use the following command to verify the remote address lists:

```
show configuration context <context_name>
```

Output similar to the following is displayed.

```
[local] host_name show configuration context <context_name>
configure
  context <context_name>
    subscriber default
    exit
  radius accounting ip remote-address list 1
    address <ipv4_address/ipv6_address> netmask <netmask>
    address <ipv4_address/ipv6_address> netmask <netmask>
    address <ipv4_address/ipv6_address> netmask <netmask>
  end
```

Notes:

- Save your configuration to flash memory, an external memory device, and/or a network location using the Exec mode command **save configuration**. For additional information on how to verify and save configuration files, refer to the *System Administration Guide* and the *Command Line Interface Reference*.

Subscriber Attribute Configuration

Subscriber attributes are configured as part of their profile. Subscriber profiles can be configured either remotely on a RADIUS server or locally on the system.

This section provides information and procedures on the attributes used to support this functionality.



Important

Since the instructions for configuring subscribers differ between RADIUS server applications, this section only provides the individual attributes that can be added to the subscriber profile. Please refer to the documentation that shipped with your RADIUS server for instructions on configuring subscribers.

Supported RADIUS Attributes

The following RADIUS attributes are used to configure remote address-based RADIUS accounting for a subscriber session. For specific information on each attribute, if you are using StarOS 12.3 or an earlier release, see the *AAA and GTPP Interface Administration and Reference*. If you are using StarOS 14.0 or a later release, refer to the *AAA Interface Administration and Reference*

- 3GPP2-Remote-Addr-Table-Index
- 3GPP2-Remote-IPv4-Address
- 3GPP2-Remote-IPv4-Addr-Octets

Configuring Local Subscriber Profiles

Use the following example to configure local subscriber profiles to support the Remote Address-based RADIUS Accounting feature:

```
configure
  context <context_name>
    subscriber name <name>
      radius accounting ip remote-address list-id <list_id>
    end
configure
  context <context_name>
    radius accounting ip remote-address collection
  end
```

Notes:

- Save your configuration to flash memory, an external memory device, and/or a network location using the Exec mode command **save configuration**. For additional information on how to verify and save configuration files, refer to the *System Administration Guide* and the *Command Line Interface Reference*.



APPENDIX T

Traffic Policing and Shaping

This chapter describes the support of per subscriber Traffic Policing and Shaping feature on Cisco's Chassis and explains the commands and RADIUS attributes that are used to implement this feature. The product Administration Guides provide examples and procedures for configuration of basic services on the system. It is recommended that you select the configuration example that best meets your service model, and configure the required elements for that model, as described in the respective product Administration Guide, before using the procedures in this chapter.



Important

Traffic Policing and Shaping is a licensed Cisco feature. A separate feature license may be required. Contact your Cisco account representative for detailed information on specific licensing requirements. For information on installing and verifying licenses, refer to the *Managing License Keys* section of the *Software Management Operations* chapter in the *System Administration Guide*.

The following topics are included:

- [Feature Description, on page 513](#)
- [Traffic Policing, on page 513](#)
- [Traffic Shaping, on page 514](#)
- [Traffic Policing Configuration, on page 514](#)
- [Traffic Shaping Configuration, on page 517](#)
- [Configuring Traffic Shaping, on page 519](#)
- [RADIUS Attributes, on page 522](#)

Feature Description

This section describes the traffic policing and traffic shaping for individual subscribers.

Traffic Policing

Traffic policing enables bandwidth limitations on individual subscribers and/or APN of a particular traffic class in 3GPP/3GPP2 service.

Bandwidth enforcement is configured and enforced independently on the downlink and the uplink directions.

The Traffic Policing feature uses the Token Bucket algorithm (a modified trTCM) as specified in RFC2698. The algorithm measures the following criteria to determine a packet:

- **Committed Data Rate (CDR):** The guaranteed rate (in bits per second) at which packets can be transmitted/received for the subscriber during the sampling interval.
- **Peak Data Rate (PDR):** The maximum rate (in bits per second) that subscriber packets can be transmitted/received for the subscriber during the sampling interval.
- **Burst-size:** The maximum number of bytes that can be transmitted/received for the subscriber during the sampling interval for both committed (CBS) and peak (PBS) rate conditions. This represents the maximum number of tokens that can be placed in the subscriber's "bucket". Committed burst size (CBS) equals the peak burst size (PBS) for each subscriber.

The system can be configured to take any of the following actions on packets that are determined to be in excess or in violation:

- **Drop:** The offending packet is discarded.
- **Transmit:** The offending packet is passed.
- **Lower the IP Precedence:** The packet's ToS bit is set to "0", thus downgrading it to Best Effort, prior to passing the packet. The packet's ToS bit was already set to "0", this action is equivalent to "Transmit".

Traffic Shaping

Traffic Shaping is a rate limiting method that provides a buffer facility for packets exceeded the configured limit. Once the packet that exceed the data rate, the packet queued inside the buffer to be delivered at a later time.

The bandwidth enforcement can be done in the downlink and uplink directions independently. If there is no more buffer space available for subscriber data the system can be configured to either drop the packets or transmit for the next scheduled traffic session.

Traffic Policing Configuration

Traffic Policing is configured on a per-subscriber basis. The subscribers can either be locally configured subscribers on the system or subscriber profiles configured on a remote RADIUS server.

In 3GPP service, traffic policing can be configured for subscribers through APN configuration as well.



Important

In 3GPP service, the attributes received from the RADIUS server supersede the settings in the APN.



Important

Commands used in the configuration samples in this section provide base functionality to the extent that the most common or likely commands and/or keyword options are presented. In many cases, other optional commands and/or keyword options are available. Refer to the *Command Line Interface Reference* for complete information regarding all commands.

Configuring Subscribers for Traffic Policing



Important Instructions for configuring RADIUS-based subscriber profiles are not provided in this document. Please refer to the documentation supplied with your server for further information.

Step 1 Configure local subscriber profiles on the system to support Traffic Policing by applying the following example configurations:

- a) To apply the specified limits and actions to the downlink (data to the subscriber):

```
configure
  context context_name
    subscriber name <user_name>
      qos traffic-police direction downlink
    end
```

- b) To apply the specified limits and actions to the uplink (data from the subscriber):

```
configure
  context context_name
    subscriber name <user_name>
      qos traffic-police direction uplink
    end
```

Notes:

- There are numerous keyword options associated with the **qos traffic-police direction { downlink | uplink }** command.
- Repeat for each additional subscriber to be configured.

Note If the exceed/violate action is set to "lower-ip-precedence", the TOS value for the outer packet becomes "best effort" for packets that exceed/violate the traffic limits regardless of what the **ip user-datagram-tos-copy** command in the Subscriber Configuration mode is configured to. In addition, the "lower-ip-precedence" option may also override the configuration of the **ip qos-dscp** command (also in the Subscriber Configuration mode). Therefore, it is recommended that command not be used when specifying this option.

Step 2 Verify the subscriber profile configuration by applying the following example configuration:

```
context <context_name>
  show subscriber configuration username <user_name>
```

Step 3 Save your configuration to flash memory, an external memory device, and/or a network location using the Exec mode command **save configuration**. For additional information on how to verify and save configuration files, refer to the *System Administration Guide* and the *Command Line Interface Reference*.

Configuring APN for Traffic Policing in 3GPP Networks

This section provides information and instructions for configuring the APN template's QoS profile in support of Traffic Policing.

The profile information is sent to the SGSN(s) in response to the GTP Create/Update PDP Context Request messages. If the QoS profile requested by the SGSN is lower than the configured QoS profile, the profile requested by the SGSN is used. If the QoS profile requested by the SGSN is higher, the configured rates are used.

The values for the committed data rate and peak data rate parameters are exchanged in the GTP messages between the GGSN and the SGSN. Therefore, the values used may be lower than the configured values. When negotiating the rate with the SGSN(s), the system converts this rate to a value that is permitted by GTP as shown in the following table:

Table 56: Permitted Values for Committed and Peak Data Rates in GTP Messages

Value (bps)	Increment Granularity (bps)
From 1000 to 63,000	1,000 (for example, 1000, 2000, 3000, ... 63000)
From 64,000 to 568,000	8,000 (for example, 64000, 72000, 80000, ... 568000)
From 576,000 to 8,640,000	64,000 (for example, 576000, 640000, 704000, ... 86400000)
From 8,700,000 to 16,000,000	100,000 bps (for example, 8700000, 8800000, 8900000, ... 16000000)

Step 1 Set parameters by applying the following example configurations:

- a) To apply the specified limits and actions to the downlink (the Gn direction):

```
configure
  context <context_name>
    apn <apn_name>
      qos rate-limit downlink
    end
```

- b) To apply the specified limits and actions to the uplink (the Gi direction):

```
configure
  context <context_name>
    apn <apn_name>
      qos rate-limit uplink
    end
```

Notes:

- There are numerous keyword options associated with **qos rate-limit { downlink | uplink }** command.
- *Optionally*, configure the maximum number of PDP contexts that can be facilitated by the APN to limit the APN's bandwidth consumption by entering the following command in the configuration:

```
max-contents primary <number> total <total_number>
```

- Repeat as needed to configure additional QoS Traffic Policing profiles.

Important If a "subscribed" traffic class is received, the system changes the class to background and sets the following: The uplink and downlink guaranteed data rates are set to 0. If the received uplink or downlink data rates are 0 and traffic policing is disabled, the default of 64 kbps is used. When enabled, the APN configured values are used. If the configured value for downlink max data rate is larger than can fit in an R4 QoS profile, the default of 64 kbps is used. If either the received uplink or downlink max data rates is non-zero, traffic policing is employed if enabled for the background class. The received values are used for responses when traffic policing is disabled.

Step 2 Verify that your APNs were configured properly by entering the following command:

```
show apn { all | name apn_name }
```

The output is a concise listing of configured APN parameter settings.

Step 3 Save your configuration to flash memory, an external memory device, and/or a network location using the Exec mode command **save configuration**. For additional information on how to verify and save configuration files, refer to the *System Administration Guide* and the *Command Line Interface Reference*.

Traffic Shaping Configuration

Traffic Shaping is configured on a per-subscriber basis. The subscribers can either be locally configured subscribers on the system or subscriber profiles configured on a remote RADIUS server.

In 3GPP service Traffic policing can be configured for subscribers through APN configuration as well.



Important In 3GPP, service attributes received from the RADIUS server supersede the settings in the APN.



Important Commands used in the configuration samples in this section provide base functionality to the extent that the most common or likely commands and/or keyword options are presented. In many cases, other optional commands and/or keyword options are available. Refer to the *Command Line Interface Reference* for complete information regarding all commands.

Configuring Subscribers for Traffic Shaping

This section provides information and instructions for configuring local subscriber profiles on the system to support Traffic Shaping.



Important Instructions for configuring RADIUS-based subscriber profiles are not provided in this document. Please refer to the documentation supplied with your server for further information.

Step 1 Set parameters by applying the following example configurations:

- a) To apply the specified limits and actions to the downlink (data to the subscriber):

```

configure
  context <context_name>
    subscriber name <user_name>
      qos traffic-shape direction downlink
    end

```

b) To apply the specified limits and actions to the uplink (data to the subscriber):

```

configure
  context <context_name>
    subscriber name <user_name>
      qos traffic-shape direction uplink
    end

```

Notes:

- There are numerous keyword options associated with **qos traffic-shape direction { downlink | uplink }** command.
- Repeat for each additional subscriber to be configured.

Important If the exceed/violate action is set to "lower-ip-precedence", the TOS value for the outer packet becomes "best effort" for packets that exceed/violate the traffic limits regardless of what the **ip user-datagram-tos-copy** command in the Subscriber Configuration mode is configured to. In addition, the "lower-ip-precedence" option may also override the configuration of the **ip qos-dscp** command (also in the Subscriber Configuration mode). Therefore, it is recommended that command not be used when specifying this option.

Step 2 Verify the subscriber profile configuration by applying the following example configuration:

```

context <context_name>
  show subscriber configuration username <user_name>

```

Step 3 Save your configuration to flash memory, an external memory device, and/or a network location using the Exec mode command **save configuration**. For additional information on how to verify and save configuration files, refer to the *System Administration Guide* and the *Command Line Interface Reference*.

Configuring APN for Traffic Shaping in 3GPP Networks

This section provides information and instructions for configuring the APN template's QoS profile in support of Traffic Shaping.

The profile information is sent to the SGSN(s) in response to the GTP Create/Update PDP Context Request messages. If the QoS profile requested by the SGSN is lower than the configured QoS profile, the profile requested by the SGSN is used. If the QoS profile requested by the SGSN is higher, the configured rates are used.

The values for the committed data rate and peak data rate parameters are exchanged in the GTP messages between the GGSN and the SGSN. Therefore, the values used may be lower than the configured values. When negotiating the rate with the SGSN(s), the system converts this rate to a value that is permitted by GTP as shown in the following table.

Table 57: Permitted Values for Committed and Peak Data Rates in GTP Messages

Value (bps)	Increment Granularity (bps)
From 1000 to 63,000	1,000 (for example, 1000, 2000, 3000, ... 63000)
From 64,000 to 568,000	8,000 (for example, 64000, 72000, 80000, ... 568000)
From 576,000 to 8,640,000	64,000 (for example, 576000, 640000, 704000, ... 86400000)
From 8,700,000 to 16,000,000	100,000 bps (for example, 8700000, 8800000, 8900000, ... 16000000)

Step 1 Set parameters by applying the following example configurations.

a) To apply the specified limits and actions to the downlink (data to the subscriber):

```
configure
  context context_name
    subscriber name user_name
      qos rate-limit downlink
    end
```

b) To apply the specified limits and actions to the uplink (data to the subscriber):

```
configure
  context context_name
    apn apn_name
      qos rate-limit uplink
    end
```

Step 2 Verify that your APNs were configured properly by entering the following command:

```
show apn { all | name apn_name }
```

The output is a concise listing of configured APN parameter settings.

Step 3 Save your configuration to flash memory, an external memory device, and/or a network location using the Exec mode command **save configuration**. For additional information on how to verify and save configuration files, refer to the *System Administration Guide* and the *Command Line Interface Reference*.

Configuring Traffic Shaping

Configuring Subscribers for Traffic Shaping

This section provides information and instructions for configuring local subscriber profiles on the system to support Traffic Shaping.



Important Instructions for configuring RADIUS-based subscriber profiles are not provided in this document. Please refer to the documentation supplied with your server for further information.

Step 1 Set parameters by applying the following example configurations:

a) To apply the specified limits and actions to the downlink (data to the subscriber):

```
configure
context <context_name>
  subscriber name <user_name>
  qos traffic-shape direction downlink
end
```

b) To apply the specified limits and actions to the uplink (data to the subscriber):

```
configure
context <context_name>
  subscriber name <user_name>
  qos traffic-shape direction uplink
end
```

Notes:

- There are numerous keyword options associated with **qos traffic-shape direction { downlink | uplink }** command.
- Repeat for each additional subscriber to be configured.

Important If the exceed/violate action is set to "lower-ip-precedence", the TOS value for the outer packet becomes "best effort" for packets that exceed/violate the traffic limits regardless of what the **ip user-datagram-tos-copy** command in the Subscriber Configuration mode is configured to. In addition, the "lower-ip-precedence" option may also override the configuration of the **ip qos-dscp** command (also in the Subscriber Configuration mode). Therefore, it is recommended that command not be used when specifying this option.

Step 2 Verify the subscriber profile configuration by applying the following example configuration:

```
context <context_name>
  show subscriber configuration username <user_name>
```

Step 3 Save your configuration to flash memory, an external memory device, and/or a network location using the Exec mode command **save configuration**. For additional information on how to verify and save configuration files, refer to the *System Administration Guide* and the *Command Line Interface Reference*.

Configuring APN for Traffic Shaping in 3GPP Networks

This section provides information and instructions for configuring the APN template's QoS profile in support of Traffic Shaping.

The profile information is sent to the SGSN(s) in response to the GTP Create/Update PDP Context Request messages. If the QoS profile requested by the SGSN is lower than the configured QoS profile, the profile requested by the SGSN is used. If the QoS profile requested by the SGSN is higher, the configured rates are used.

The values for the committed data rate and peak data rate parameters are exchanged in the GTP messages between the GGSN and the SGSN. Therefore, the values used may be lower than the configured values. When negotiating the rate with the SGSN(s), the system converts this rate to a value that is permitted by GTP as shown in the following table.

Table 58: Permitted Values for Committed and Peak Data Rates in GTP Messages

Value (bps)	Increment Granularity (bps)
From 1000 to 63,000	1,000 (for example, 1000, 2000, 3000, ... 63000)
From 64,000 to 568,000	8,000 (for example, 64000, 72000, 80000, ... 568000)
From 576,000 to 8,640,000	64,000 (for example, 576000, 640000, 704000, ... 86400000)
From 8,700,000 to 16,000,000	100,000 bps (for example, 8700000, 8800000, 8900000, ... 16000000)

Step 1 Set parameters by applying the following example configurations.

a) To apply the specified limits and actions to the downlink (data to the subscriber):

```
configure
  context context_name
    subscriber name user_name
      qos rate-limit downlink
    end
```

b) To apply the specified limits and actions to the uplink (data to the subscriber):

```
configure
  context context_name
    apn apn_name
      qos rate-limit uplink
    end
```

Step 2 Verify that your APNs were configured properly by entering the following command:

```
show apn { all | name apn_name }
```

The output is a concise listing of configured APN parameter settings.

Step 3 Save your configuration to flash memory, an external memory device, and/or a network location using the Exec mode command **save configuration**. For additional information on how to verify and save configuration files, refer to the *System Administration Guide* and the *Command Line Interface Reference*.

RADIUS Attributes

Traffic Policing for CDMA Subscribers

The RADIUS attributes listed in the following table configure Traffic Policing for CDMA subscribers (PDSN and HA) that are configured on remote RADIUS servers. See the *AAA Interface Administration and Reference* for more information on these attributes.

Table 59: RADIUS Attributes Required for Traffic Policing Support for CDMA Subscribers

Attribute	Description
SN-QoS-Tp-Dnlk (or SN1-QoS-Tp-Dnlk)	Enable or disable traffic policing in the downlink direction.
SN-Tp-Dnlk-Committed-Data-Rate (or SN1-Tp-Dnlk-Committed-Data-Rate)	Specifies the downlink committed data rate in bps.
SN-Tp-Dnlk-Peak-Data-Rate (or SN1-Tp-Dnlk-Committed-Data-Rate)	Specifies the downlink peak data rate in bps.
SN-Tp-Dnlk-Burst-Size (or SN1-Tp-Dnlk-Burst-Size)	Specifies the downlink-burst-size in bytes. NOTE: This parameter must be configured to the greater of the following two values: 1) 3 times greater than packet MTU for the subscriber connection, OR 2) 3 seconds worth of token accumulation within the "bucket" for the configured peak data rate.
SN-Tp-Dnlk-Exceed-Action (or SN1-Tp-Dnlk-Exceed-Action)	Specifies the downlink exceed action to perform.
SN-Tp-Dnlk-Violate-Action (or SN1-Tp-Dnlk-Violate-Action)	Specifies the downlink violate action to perform.
SN-QoS-Tp-Uplk (or SN1-QoS-Tp-Uplk)	Enable/disable traffic policing in the downlink direction.
SN-Tp-Uplk-Committed-Data-Rate (or SN1-Tp-Uplk-Committed-Data-Rate)	Specifies the uplink committed data rate in bps.
SN-Tp-Uplk-Peak-Data-Rate (or SN1-Tp-Uplk-Committed-Data-Rate)	Specifies the uplink peak data rate in bps.

Attribute	Description
SN-Tp-Uplk-Burst-Size (or SN1-Tp-Uplk-Burst-Size)	Specifies the uplink burst size in bytes. Note This parameter must be configured to at least the greater of the following two values: 1) 3 times greater than packet MTU for the subscriber connection, OR 2) 3 seconds worth of token accumulation within the "bucket" for the configured peak data rate.
SN-Tp-Uplk-Exceed-Action (or SN1-Tp-Uplk-Exceed-Action)	Specifies the uplink exceed action to perform.
SN-Tp-Uplk-Violate-Action (or SN1-Tp-Uplk-Violate-Action)	Specifies the uplink violate action to perform.

Traffic Policing for UMTS Subscribers

The RADIUS attributes listed in the following table are used to configure Traffic Policing for UMTS subscribers configured on remote RADIUS servers. More information on these attributes can be found in the *AAA Interface Administration and Reference*.

Table 60: RADIUS Attributes Required for Traffic Policing Support for UMTS Subscribers

Attribute	Description
SN-QoS-Conversation-Class (or SN1-QoS-Conversation-Class)	Specifies the QoS Conversation Traffic Class.
SN-QoS-Streaming-Class (or SN1-QoS-Streaming-Class)	Specifies the QoS Streaming Traffic Class.
SN-QoS-Interactive1-Class (or SN1-QoS-Interactive1-Class)	Specifies the QoS Interactive Traffic Class.
SN-QoS-Interactive2-Class (or SN1-QoS-Interactive2-Class)	Specifies the QoS Interactive2 Traffic Class.
SN-QoS-Interactive3-Class (or SN1-QoS-Interactive3-Class)	Specifies the QoS Interactive3 Traffic Class.
SN-QoS-Background-Class (or SN1-QoS-Background-Class)	Specifies the QoS Background Traffic Class.

Attribute	Description
SN-QoS-Traffic-Policy (or SN1-QoS-Traffic-Policy)	<p>This compound attribute simplifies sending QoS values for Traffic Class (the above attributes), Direction, Burst-Size, Committed-Data-Rate, Peak-Data-Rate, Exceed-Action, and Violate-Action from the RADIUS server.</p> <p>This attribute can be sent multiple times for different traffic classes. If Class is set to 0, it applies across all traffic classes.</p>