



SAEGW Administration Guide, StarOS Release 21.28

First Published: 2022-09-29

Last Modified: 2024-04-30

Americas Headquarters

Cisco Systems, Inc.
170 West Tasman Drive
San Jose, CA 95134-1706
USA
<http://www.cisco.com>
Tel: 408 526-4000
800 553-NETS (6387)
Fax: 408 527-0883

THE SPECIFICATIONS AND INFORMATION REGARDING THE PRODUCTS IN THIS MANUAL ARE SUBJECT TO CHANGE WITHOUT NOTICE. ALL STATEMENTS, INFORMATION, AND RECOMMENDATIONS IN THIS MANUAL ARE BELIEVED TO BE ACCURATE BUT ARE PRESENTED WITHOUT WARRANTY OF ANY KIND, EXPRESS OR IMPLIED. USERS MUST TAKE FULL RESPONSIBILITY FOR THEIR APPLICATION OF ANY PRODUCTS.

THE SOFTWARE LICENSE AND LIMITED WARRANTY FOR THE ACCOMPANYING PRODUCT ARE SET FORTH IN THE INFORMATION PACKET THAT SHIPPED WITH THE PRODUCT AND ARE INCORPORATED HEREIN BY THIS REFERENCE. IF YOU ARE UNABLE TO LOCATE THE SOFTWARE LICENSE OR LIMITED WARRANTY, CONTACT YOUR CISCO REPRESENTATIVE FOR A COPY.

The Cisco implementation of TCP header compression is an adaptation of a program developed by the University of California, Berkeley (UCB) as part of UCB's public domain version of the UNIX operating system. All rights reserved. Copyright © 1981, Regents of the University of California.

NOTWITHSTANDING ANY OTHER WARRANTY HEREIN, ALL DOCUMENT FILES AND SOFTWARE OF THESE SUPPLIERS ARE PROVIDED "AS IS" WITH ALL FAULTS. CISCO AND THE ABOVE-NAMED SUPPLIERS DISCLAIM ALL WARRANTIES, EXPRESSED OR IMPLIED, INCLUDING, WITHOUT LIMITATION, THOSE OF MERCHANTABILITY, FITNESS FOR A PARTICULAR PURPOSE AND NON-INFRINGEMENT OR ARISING FROM A COURSE OF DEALING, USAGE, OR TRADE PRACTICE.

IN NO EVENT SHALL CISCO OR ITS SUPPLIERS BE LIABLE FOR ANY INDIRECT, SPECIAL, CONSEQUENTIAL, OR INCIDENTAL DAMAGES, INCLUDING, WITHOUT LIMITATION, LOST PROFITS OR LOSS OR DAMAGE TO DATA ARISING OUT OF THE USE OR INABILITY TO USE THIS MANUAL, EVEN IF CISCO OR ITS SUPPLIERS HAVE BEEN ADVISED OF THE POSSIBILITY OF SUCH DAMAGES.

Any Internet Protocol (IP) addresses and phone numbers used in this document are not intended to be actual addresses and phone numbers. Any examples, command display output, network topology diagrams, and other figures included in the document are shown for illustrative purposes only. Any use of actual IP addresses or phone numbers in illustrative content is unintentional and coincidental.

All printed copies and duplicate soft copies of this document are considered uncontrolled. See the current online version for the latest version.

Cisco has more than 200 offices worldwide. Addresses and phone numbers are listed on the Cisco website at www.cisco.com/go/offices.

Cisco and the Cisco logo are trademarks or registered trademarks of Cisco and/or its affiliates in the U.S. and other countries. To view a list of Cisco trademarks, go to this URL: <https://www.cisco.com/c/en/us/about/legal/trademarks.html>. Third-party trademarks mentioned are the property of their respective owners. The use of the word partner does not imply a partnership relationship between Cisco and any other company. (1721R)

© 2022-2024 Cisco Systems, Inc. All rights reserved.



CONTENTS

PREFACE

About this Guide	xlix
Conventions Used	I
Supported Documents and Resources	li
Related Common Documentation	li
Related Product Documentation	lii
Obtaining Documentation	lii
Contacting Customer Support	lii

CHAPTER 1

SAEGW Gateway Overview	1
SAEGW Product Description	1
Platform Requirements	3
Licenses	3
S-GW Product Description	3
Platform Requirements	5
Licenses	5
P-GW Product Description	5
Platform Requirements	8
Licenses	8
S-GW Network Deployment(s)	8
Serving Gateway in the E-UTRAN/EPC Network	8
Supported Logical Network Interfaces (Reference Points)	10
P-GW Network Deployment(s)	14
PDN Gateway in the E-UTRAN/EPC Network	14
Supported Logical Network Interfaces (Reference Points)	16
PDN Gateway Supporting eHRPD to E-UTRAN/EPC Connectivity	21
Supported Logical Network Interfaces (Reference Points)	25

S-GW Features and Functionality - Base Software	29
3GPP Release 12 Cause-Code IE Support	29
Abnormal Bearer Termination Cause in CDR	29
ANSI T1.276 Compliance	30
APN-level Traffic Policing	30
Backup and Recovery of Key KPI Statistics	30
Bulk Statistics Support	31
CDR Support for Including LAPI (Signaling Priority)	31
Circuit Switched Fall Back (CSFB) Support	32
Closed Subscriber Group Support	32
Collision Counter Support in the GTP Layer	32
Congestion Control	33
Dedicated Bearer Timeout Support on the S-GW	34
Downlink Delay Notification	34
Value Handling	34
Throttling	35
EPS Bearer ID and ARP Support	35
DSCP Ingress and Egress and DSCP Marking at the APN Profile	35
Dynamic GTP Echo Timer	35
Event Reporting	35
GTP-C Path Failure Enhancements and Improved Debugging Tools	36
Idle-mode Signaling Reduction Support	37
IMSI/IMEI Available in System Event Logs of Type Error and Critical	37
IP Access Control Lists	39
IPv6 Capabilities	40
LIPA Support	40
Location Reporting	41
Mapping High Throughput Sessions on Session Managers	41
MME Restoration Support	42
S-GW NTSR Enhancement	42
Multiple PDN Support	42
Node Functionality GTP Echo	43
Online/Offline Charging	43
Online: Gy Reference Interface	43

Offline: Gz Reference Interface	44
Offline: Rf Reference Interface	44
Operator Policy Support	44
Optimization for egtpinmgr Recovery	45
Peer GTP Node Profile Configuration Support	45
P-GW Restart Notification Support	45
QoS Bearer Management	46
Removal of Private Extension-based Overcharging Feature	47
Rf Diameter Accounting	50
S-GW Collision Handling	51
Viewing S-GW Collision Handling Statistics	51
S-GW Session Idle Timer	52
Subscriber Level Trace	52
Threshold Crossing Alerts (TCA) Support	53
ULI Enhancements	54
P-GW Features and Functionality - Base Software	54
3GPP R9 Volume Charging Over Gx	54
AAA Server Groups	55
ANSI T1.276 Compliance	55
APN Support	55
Assume Positive for Gy-based Quota Tracking	56
Bit Rate Mapping Across Gx and GTP-based Interfaces	57
Backup and Recovery of Key KPI Statistics	57
Bulk Statistics Support	57
Collision Counter Support in GTP Layer	59
Congestion Control	60
Default and Dedicated EPC Bearers	61
DHCP Support	61
Support for Option 26 in DHCP	62
DHCPv6 Support	62
Direct Tunnel Support	63
DNS Support for IPv4/IPv6 PDP Contexts	64
Domain Based Flow Definitions	64
DSCP Marking	64

GTP-U on per APN Basis	65
Dynamic GTP Echo Timer	66
Dynamic Policy Charging Control (Gx Reference Interface)	66
Enhanced Charging Service (ECS)	67
Content Analysis Support	68
Content Service Steering	69
Support for Multiple Detail Record Types	70
Diameter Credit Control Application	70
Accept TCP Connections from DCCA Server	71
Gy Interface Support	71
Enhancement to New Call Setup after Sessmgr or DPC Failure	72
Framed-Route Attribute Support	73
Gn/Gp Handoff Support	73
GTP-C Path Failure Enhancements and Improved Debugging Tools	74
IMS Emergency Bearer Handling	75
IMSI/IMEI Available in System Event Logs of Type Error and Critical	75
IP Access Control Lists	77
IP Address Hold Timers	78
IPv6 Capabilities	78
IPv6 MTU Option Support in RA Message	79
IPv6 Prefix-Based Search Support for LTE-WiFi Handoff	80
Local Break-Out	81
Mapping High Throughput Sessions on Session Managers	81
MPLS EXP Marking of User Plane Traffic	82
Mobile IP Registration Revocation	83
MTU Size PCO	83
Multiple PDN Support	84
Node Functionality GTP Echo	84
Non-Optimized e-HRPD to Native LTE (E-UTRAN) Mobility Handover	84
Online/Offline Charging	85
Online Charging	85
Offline Charging	86
Optimization for egtpinmgr Recovery	87
P-CSCF Recovery	87

Peer GTP Node Profile Configuration Support	87
Per QCI Packet Drop Counters and ARP Granularity for QCI Level Counters	88
PMIPv6 Heartbeat	88
Proxy Mobile IPv6 (S2a)	89
QoS Bearer Management	89
RADIUS Support	90
Removal of Private Extension-based Overcharging Support	91
S-GW Restoration Support	94
Source IP Address Validation	95
SRVCC PS-to-CS Handover Indication Support	95
Subscriber Level Trace	96
3GPP Tracing to Intercept Random Subscriber	97
Support for One Million S1-U Peers on the S-GW	97
TCP Window Size	98
Threshold Crossing Alerts (TCA) Support	99
UE Time Zone Reporting	100
Virtual APN Support	100
P-GW Features and Functionality - Inline Service Support	100
Content Filtering	101
Integrated Adult Content Filter	101
ICAP Interface	101
Header Enrichment: Header Insertion and Encryption	102
Network Address Translation (NAT)	103
NAT64 Support	103
Peer-to-Peer Detection	104
Personal Stateful Firewall	104
S-GW Features and Functionality - Optional Enhanced Feature Software	105
Direct Tunnel	105
Intelligent Paging for ISR	106
Inter-Chassis Session Recovery	107
IP Security (IPSec) Encryption	108
Lawful Intercept	108
Layer 2 Traffic Management (VLANs)	108
New Call Policy for Stale Sessions	109

New Standard QCI Support	109
Overcharging Protection Support	109
Paging Policy Differentiation	110
R12 Load and Overload Support	111
Operation	112
Separate Paging for IMS Service Inspection	112
Session Recovery Support	112
S-GW Paging Enhancements	113
P-GW Features and Functionality - Optional Enhanced Feature Software	114
AAA and Prefix Delegation DHCP Correlation	114
APN Backoff Timer Support	114
Cause IE Enhancement for Delete Bearer Request	115
Dynamic RADIUS Extensions (Change of Authorization)	115
GRE Protocol Interface Support	116
GTP-Based S2a Interface Support on the SAEGW	117
GTP-based S2b Interface Support on the Standalone P-GW and SAEGW	117
GTP Throttling	118
Bypass Rate Limit Function	118
HSS and PCRF Based P-CSCF Restoration Support	119
Inter-Chassis Session Recovery	119
IP Security (IPSec) Encryption	120
IPv6 Prefix Delegation from the RADIUS Server and the Local Pool	121
L2TP LAC Support	121
Lawful Intercept	122
Layer 2 Traffic Management (VLANs)	122
Local Policy Decision Engine	122
MPLS Forwarding with LDP	123
NEMO Service Supported	123
NEMO Support in GGSN	124
Network Provided Location Information for IMS	124
New Call Policy for Stale Sessions	124
Non-standard QCI Support	125
Paging Policy Differentiation	125
Per QCI Packet Drop Counters and ARP Granularity for QCI Level Counters	126

Piggyback Support on S2b Interface	127
R12 Load and Overload Support	127
Operation	127
Session Recovery Support	128
S-GW Paging Enhancements	128
Smartphone Tethering Detection Support	129
Traffic Policing	129
Traffic Shaping	130
UBR Suppression Feature	130
User Location Information Reporting	131
3GPP ULI Reporting Support Enhanced	132
How the Serving Gateway Works	134
GTP Serving Gateway Call/Session Procedures in an LTE-SAE Network	134
Subscriber-initiated Attach (initial)	134
Subscriber-initiated Detach	137
How the PDN Gateway Works	138
PMIPv6 PDN Gateway Call/Session Procedures in an eHRPD Network	138
Initial Attach with IPv6/IPv4 Access	138
PMIPv6 Lifetime Extension without Handover	140
PDN Connection Release Initiated by UE	141
PDN Connection Release Initiated by HSGW	142
PDN Connection Release Initiated by P-GW	143
GTP PDN Gateway Call/Session Procedures in an LTE-SAE Network	144
Subscriber-initiated Attach (initial)	144
Subscriber-initiated Detach	146
S-GW Supported Standards	147
3GPP References	148
Release 12 3GPP References	148
Release 11 3GPP References	148
Release 10 3GPP References	148
Release 9 Supported Standards	149
Release 8 Supported Standards	149
3GPP2 References	150
IETF References	150

- Object Management Group (OMG) Standards 151
- P-GW Supported Standards 151
 - Release 12 3GPP References 151
 - Release 11 3GPP References 152
 - Release 10 3GPP References 152
 - Release 9 3GPP References 153
 - Release 8 3GPP References 154
 - 3GPP2 References 155
 - IETF References 155
 - Object Management Group (OMG) Standards 156

CHAPTER 2

SAE Gateway Configuration 157

- Configuring an SAEGW Service 157
 - Information Required 157
 - Required Local Context Configuration Information 158
 - Required SAEGW Context Configuration Information 158
 - SAEGW Configuration 159
 - Initial Configuration 159
 - SAEGW Service Configuration 160
 - Verifying and Saving the Configuration 160
- Configuring an eGTP S-GW Service 160
 - Information Required 161
 - Required S-GW Ingress Context Configuration Information 161
 - Required S-GW Egress Context Configuration Information 162
 - How This Configuration Works 163
 - eGTP S-GW Configuration 164
 - Initial Configuration 165
 - eGTP Configuration 167
 - Verifying and Saving the Configuration 169
- Configuring Optional Features on the eGTP S-GW 169
 - Configuring the GTP Echo Timer 169
 - Default GTP Echo Timer Configuration 169
 - Dynamic GTP Echo Timer Configuration 171
 - Configuring GTP Offline Accounting on the S-GW 175

Configuring Diameter Offline Accounting on the S-GW	176
Configuring APN-level Traffic Policing on the S-GW	177
Configuring X.509 Certificate-based Peer Authentication	178
Configuring Dynamic Node-to-Node IP Security on the S1-U and S5 Interfaces	179
Creating and Configuring an IPSec Transform Set	179
Creating and Configuring an IKEv2 Transform Set	179
Creating and Configuring a Crypto Template	180
Binding the S1-U and S5 IP Addresses to the Crypto Template	180
Configuring ACL-based Node-to-Node IP Security on the S1-U and S5 Interfaces	181
Creating and Configuring a Crypto Access Control List	182
Creating and Configuring an IPSec Transform Set	182
Creating and Configuring an IKEv2 Transform Set	183
Creating and Configuring a Crypto Map	183
Configuring R12 Load Control Support	184
Configuring R12 Overload Control Support	185
Configuring S4 SGSN Handover Capability	186
Configuring an eGTP P-GW Service	187
Information Required	187
Required P-GW Context Configuration Information	187
Required PDN Context Configuration Information	188
Required AAA Context Configuration Information	190
How This Configuration Works	193
eGTP P-GW Configuration	195
Initial Configuration	196
P-GW Service Configuration	200
P-GW PDN Context Configuration	200
Active Charging Service Configuration	201
Policy Configuration	203
Verifying and Saving the Configuration	205
DHCP Service Configuration	205
DHCP Service Creation	206
DHCP Server Parameter Configuration	206
DHCP Service Configuration Verification	207
DHCPv6 Service Configuration	208

- DHCPv6 Service Creation **208**
- DHCPv6 Server Parameter Configuration **209**
- DHCPv6 Client Parameter Configuration **209**
- DHCPv6 Profile Configuration **210**
- Associate DHCPv6 Configuration **211**
- DHCPv6 Service Configuration Verification **211**
- Configuring Optional Features on the P-GW **212**
 - Configuring ACL-based Node-to-Node IP Security on the S5 Interface **212**
 - Creating and Configuring a Crypto Access Control List **213**
 - Creating and Configuring an IPSec Transform Set **213**
 - Creating and Configuring an IKEv2 Transform Set **213**
 - Creating and Configuring a Crypto Map **214**
 - Configuring APN as Emergency **215**
 - Configuring Dynamic Node-to-Node IP Security on the S5 Interface **215**
 - Creating and Configuring an IPSec Transform Set **216**
 - Creating and Configuring an IKEv2 Transform Set **216**
 - Creating and Configuring a Crypto Template **217**
 - Binding the S5 IP Address to the Crypto Template **217**
 - Configuring the GTP Echo Timer **218**
 - Default GTP Echo Timer Configuration **218**
 - Dynamic GTP Echo Timer Configuration **220**
 - Configuring GTP Offline Accounting on the P-GW **222**
 - Configuring Local QoS Policy **224**
 - Creating and Configuring a Local QoS Policy **224**
 - Binding a Local QoS Policy **225**
 - Verifying Local QoS Policy **226**
 - Configuring X.509 Certificate-based Peer Authentication **226**
 - Configuring R12 Load Control Support **227**
 - Configuring R12 Overload Control Support **228**
 - Configuring Guard Timer on Create Session Request Processing **228**
 - Configuring Session Timeout **229**
 - Configuring RLF Bypass **229**
 - Configuring the Throttling Override Policy Mode **229**
 - Configuring RLF Bypass Feature **230**

CHAPTER 3	Monitoring the Service	231
	Monitoring System Status and Performance	231
	Configuring the SAEGW to Include the IMSI/IMEI in System Event Logs of Type Error and Critical	235
	Configuring the SAEGW to Include the IMSI/IMEI in System Event Logs of Type Error and Critical	237
	Clearing Statistics and Counters	237
<hr/>		
CHAPTER 4	3GPP Changes to the Gx Interface	239
	Feature Information	239
	Feature Changes	240
	Limitations	240
<hr/>		
CHAPTER 5	5G NSA for SAEGW	241
	Feature Summary and Revision History	241
	Feature Description	243
	How It Works	247
	Architecture	247
	Limitations	249
	Flows	249
	Supported Standards	251
	Configuring 5G NSA for SAEGW	252
	Enabling DCNR in P-GW Service	252
	Configuring Bearer Duration Statistics for URLLC QCI	252
	Configuring EGTPC QCI Statistics for URLLC QCI	253
	Configuring Extended Bandwidth with New Radio	253
	Configuring Network-Initiated Setup/Teardown Events for URLLC QCI	254
	Configuring URLLC QCI in APN Configuration	254
	Configuring URLCC QCI In Charging Action	255
	Configuring URLCC QCI in QCI QOS Mapping Table	255
	Monitoring and Troubleshooting	256
	Show Commands and Outputs	256
	Bulk Statistics	261

APN Schema	261
P-GW Schema	262
SAEGW Schema	263
S-GW Schema	263
System Schema	264

CHAPTER 6	APN-Backoff Timer Support	267
	Feature Description	267
	Functionality	267
	GTP-C Overload Feature and the M2M License	268
	Licensing	268
	Configuring APN Backoff Timer Support on the P-GW/SAEGW	269
	Configuring LAPI Behavior	269
	Configuring the APN Backoff Timer and Jitter Values	269
	Verifying the Configuration	270
	Monitoring the Feature	270
	Bulk Statistics	270
	APN Schema	270
	P-GW Schema	270
	SAEGW Schema	271
	Show Command Output	271
	show apn name	271
	show apn statistics	271
	show configuration apn name	271
	show pgw-service statistics	271
	show session disconnect-reasons	271

CHAPTER 7	Backup and Recovery of Key KPI Statistics	273
	Feature Description	273
	How It Works	273
	Architecture	274
	Limitations	275
	Configuring Backup Statistics Feature	275
	Configuration	275

Verifying the Backup Statistics Feature Configuration 276

CHAPTER 8

Bearer Re-establishment 277

Feature Summary and Revision History 277
 Introduction to Bearer Re-establishment 278
 How it Works 278
 Enabling Modify Bearer Request Forward from S-GW to P-GW 278
 P-GW Invokes Local Policy with New Event Restore-Bearers 279
 Show Commands and Outputs 280

CHAPTER 9

Bulkstats for GTP-C Messages by ARP Value 283

Feature Description 283
 Limitations 284
 Licensing 284
 Performance Indicator Changes 284
 S-GW Ingress S4 Interface 284
 S-GW Ingress S11 Interface 285
 S-GW Egress GTP-based S5/S8 Interface 286
 P-GW Ingress GTP-based S5/S8 Interface 287
 clear egtpc 287
 P-GW eGTP-C S5/S8 Schema 288
 eGTP-C Schema 288

CHAPTER 10

CoA, RADIUS DM, and Session Redirection (Hotlining) 291

RADIUS Change of Authorization and Disconnect Message 291
 CoA Overview 291
 DM Overview 292
 License Requirements 292
 Enabling CoA and DM 292
 Enabling CoA and DM 292
 CoA and DM Attributes 293
 CoA and DM Error-Cause Attribute 294
 Viewing CoA and DM Statistics 294
 Session Redirection (Hotlining) 296

- Overview 296
 - License Requirements 296
- Operation 296
 - ACL Rule 296
 - Redirecting Subscriber Sessions 296
 - Session Limits On Redirection 297
 - Stopping Redirection 297
 - Handling IP Fragments 297
 - Recovery 297
 - AAA Accounting 297
 - Viewing the Redirected Session Entries for a Subscriber 297

CHAPTER 11

Collision Handling on the P-GW/SAEGW/S-GW 301

- Feature Description 301
 - Relationships to Other Features 301
- How It Works 301
 - Collision Handling 301
 - Example Collision Handling Scenarios 302
 - Limitations 304
 - Standards Compliance 304
- Configuring Collision Handling 304
 - Configuring DBcmd Message Behavior 304
 - Verifying the Configuration 305
- Monitoring the Collision Handling Feature 305
 - Collision Handling Show Command(s) and/or Outputs 305
 - show configuration 305
 - show egtp-service all | name 305
 - show egtp statistics verbose 305

CHAPTER 12

Disable Cause Source Enhancement 307

- Feature Summary and Revision History 307
- Feature Description 308
- Configuring cause-source 308
- Monitoring and Troubleshooting 308

Show Commands and/or Outputs	308
show egtp-service name egtp	308
Troubleshooting	308

CHAPTER 13**Direct Tunnel for 4G (LTE) Networks 311**

Direct Tunnel for 4G Networks - Feature Description	311
How It Works	314
DT Establishment Logic	314
Establishment of Direct Tunnel	315
Direct Tunnel Activation for Primary PDP Context	316
Direct Tunnel Activation for UE Initiated Secondary PDP Context	316
RAB Release with Direct Tunnel	317
Iu Release with Direct Tunnel	318
Service Request with Direct Tunnel	319
Downlink Data Notification with Direct Tunnel when UE in Connected State	320
Downlink Data Notification with Direct Tunnel when UE in Idle State	320
Intra SGSN Routing Area Update without SGW Change	321
Routing Area Update with S-GW Change	324
Intra SRNS with S-GW Change	327
Intra SRNS without S-GW Change	327
New SRNS with S-GW Change and Direct Data Transfer	329
New SRNS with S-GW Change and Indirect Data Transfer	330
Old SRNS with Direct Data Transfer	332
Old SRNS with Indirect Data Transfer	333
Network Initiated Secondary PDP Context Activation	335
PGW Init Modification when UE is Idle	336
Limitations	337
Standards Compliance	338
Configuring Support for Direct Tunnel	338
Configuring Direct Tunnel on an S4-SGSN	338
Enabling Setup of GTP-U Direct Tunnel	338
Enabling Direct Tunnel to RNCs	339
Restricting Direct Tunnels	339
Verifying the Call-Control Profile Configuration	340

- Verifying the RNC Configuration 340
- Configuring S12 Direct Tunnel Support on the S-GW 340
- Monitoring and Troubleshooting Direct Tunnel 341
 - show subscribers sgsn-only 341
 - show gmm-sm statistics sm-only 342
- Direct Tunnel Bulk Statistics 342

CHAPTER 14

- Dynamic Guaranteed Bit Rate 343**
 - Feature Summary and Revision History 343
 - Feature Description 344
 - How It Works 344
 - Limitations and Restrictions 345
 - Configuring Dedicated GBR Bearer 346
 - trigger 346
 - committed-data-rate 347
 - step-up 347
 - step-down 347
 - Sample Configuration 348

CHAPTER 15

- Embed IMSI into Session Id 349**
 - Feature Summary and Revision History 349
 - Feature Description 350
 - How It Works 350
 - Limitations 350
 - Configuring Diameter Accounting Interim Interval 351
 - Monitoring and Troubleshooting 352
 - Show Commands and Outputs 352
 - show configuration 352
 - show configuration [verbose] 352

CHAPTER 16

- Enabling S6b for IMS APN 353**
 - Feature Summary and Revision History 353
 - Feature Changes 354
 - Configuring Commands for Enabling S6b for IMS APN 354

Enabling S6b Authentication for Trusted Wi-Fi 355

Show Commands and Outputs 356

show apn name 356

show config apn intershat 356

CHAPTER 17

Expanded Prioritization for VoLTE/Emergency Calls 357

Feature Description 357

Relationships to Other Features 357

Licensing 358

How It Works 359

Configuring Expanded Prioritization for VoLTE/Emergency Calls 360

Configuring eMPS Profile and its Associated Attributes 360

Associating an eMPS Profile with P-GW Service 361

Associating an eMPS Profile with S-GW Service 361

Monitoring and Troubleshooting the Expanded Prioritization for VoLTE/Emergency Calls 362

Show Command(s) and/or Outputs 362

Bulkstats for Expanded Prioritization for VoLTE/Emergency Calls 366

CHAPTER 18

Extended QCI Options 369

Per QCI Packet Drop Counters and ARP Granularity for QCI Level Counters 369

Feature Description 369

Configuring ARP Granularity for QCI Level Counters 370

Create a Stats Profile 370

Enable the Collection of Packet Drop Statistics 371

Enable the Collection of QCI/ARP Level Statistics 371

Associate a Stats Profile with an APN 372

Verify the Configuration 372

Monitoring Per QCI Packet Drop Counters and ARP Granularity for QCI Level Counters 373

Bulk Statistics 373

Show Commands 374

DSCP Marking Based on Both QCI and ARP Values 382

Feature Description 382

Relationships to Other Features 383

Licensing 383

- How It Works **383**
- Configuring DSCP Marking Based on Both QCI and ARP Values **384**
 - Configuring QCI-QoS Mapping **384**
 - Associating QCI-QoS Mapping Configuration **384**
 - Configuring CS5 Marking for GTP-C **385**
 - Verifying the Configuration **385**
- Monitoring DSCP Marking Based on Both QCI and ARP Values **385**
 - Output of Show Commands **385**
- New Standard QCI Support **385**
 - Feature Description **386**
 - Licensing **386**
 - How it Works **386**
 - Expected Call Flow Output **387**
 - Configuring New Standard QCIs **395**
 - Configuring QCI-QoS Mapping **395**
 - Configuring Local QCI Mapping for Gn/Gp QoS Support **396**
 - Configuring Transaction Rate Network Initiated Setup/Teardown Events **396**
 - Enable Mission Critical QCIs **397**
 - Verifying the Configuration **397**
 - Monitoring the Feature **397**
 - Bulk Statistics **397**
 - Show Commands **413**
- Non-standard QCI Support **422**
 - Feature Description **422**
 - Licensing **422**
 - How It Works **422**
 - Limitations **422**
 - Standards Compliance **422**
 - Configuring Non-standard QCI Support **422**
 - Configuring Non-standard QCI Support in P-GW **423**
 - Monitoring Non-standard QCI Support **424**
 - Bulk Statistics **424**
 - Output of Show Commands **424**

CHAPTER 19**GGSN UPC Collision Handling 425**

- GGSN UPC Collision Handling 425
 - Feature Description 425
 - Limitations 425
 - Configuring GGSN UPC Collision Handling 426
 - gtpc handle-collision 426
 - Verifying the Configuration 427
 - Monitoring and Troubleshooting GGSN UPC Collision Handling 427
 - Show Commands for GGSN UPC Collision Handling 427

CHAPTER 20**GRE Protocol Interface 429**

- Introduction 429
- Supported Standards 430
- Supported Networks and Platforms 431
- Licenses 431
- Services and Application on GRE Interface 431
- How GRE Interface Support Works 431
 - Ingress Packet Processing on GRE Interface 431
 - Egress Packet Processing on GRE Interface 433
- GRE Interface Configuration 434
 - Virtual Routing And Forwarding (VRF) Configuration 434
 - GRE Tunnel Interface Configuration 435
 - Enabling OSPF for VRF 435
 - Associating IP Pool and AAA Group with VRF 436
 - Associating APN with VRF 436
 - Static Route Configuration 436
- Verifying Your Configuration 437

CHAPTER 21**GTP-based S2b Interface Support on the P-GW and SAEGW 439**

- Feature Description 439
 - GTP-based S2b Interface Support on the Standalone P-GW and SAEGW 439
 - GTP-based S2a Interface Support on the Standalone P-GW and SAEGW 440
- Relationships to Other Features 441

- How the S2b Architecture Works 441
 - Standalone P-GW Architecture for S2b Interface Support 441
 - SAEGW Architecture for S2b Interface Support 442
 - Limitations on S2b Interface Support for the P-GW and SAEGW 442
 - Standalone P-GW Call Flows 443
 - SAEGW GTP-based S2b Call Flows 452
 - Standards Compliance 463
- How the S2a Architecture Works 463
 - Standalone P-GW and SAEGW Architecture for S2a Interface Support 463
 - Limitations on S2a Interface Support on the P-GW and SAEGW 465
 - Standalone P-GW S2a Call Flows 465
 - SAEGW S2a Call Flows 471
- Configuring the GTP-based S2b Interface on the P-GW and SAEGW 477
 - Configuring GTP-based S2b Interface Support 477
 - Verifying the Configuration 478
- Monitoring the GTP-based S2b Interface Feature 478
 - GTP-based S2b Interface Show Commands 478
 - show pgw-service statistics all 478
 - show subscribers epdg-address 479
 - show subscribers saegw-only epdg-address 479
 - show subscribers saegw-only interface-type S2bGTP 479
 - show subscribers summary pgw-address 479
 - show subscribers pgw-only full all 479
 - show subscribers pgw-only epdg-address 479
 - show subscribers summary epdg-address 479
 - show subscribers summary interface-type S2bGTP 479
 - show subscribers saegw-only full all 479
 - show saegw-service statistics all function pgw 480
- Monitoring the GTP-based S2a Interface Feature 480
 - GTP-based S2a Interface Show Commands 480
 - show pgw-service statistics all 480
 - show saegw-service statistics all 480
 - show saegw-service statistics all function-pgw 481
 - show session-subsystem facility sessmgr service-type pgw-ingress 481

CHAPTER 22**3GPP R12 GTP-C Load and Overload Control Support on the P-GW, SAEGW, and S-GW 483**

show subscribers pgw-only full all	481
show subscribers saegw-only full all	481
show subscribers saegw-only interface-type S2aGTP	481
show subscribers summary interface-type S2aGTP	481
show subscribers summary pgw-address	481
<hr/>	
Feature Description	483
Relationships to Other Features	484
How It Works	484
Creating and Configuring a 3GPP R12 GTP-C Load Control Profile	485
Configuration Overview	485
Creating the GTP R12 Load Control Profile	485
Configuring the 3GPP R12 Load Control Profile Weightage Settings	486
Configuring the 3GPP R12 Load Control Profile Inclusion Frequency	486
Configuring the 3GPP R12 Load Control Threshold	487
Configuring 3GPP R12 Load Control Information Handling	487
Configuring 3GPP R12 Load Control Information Publishing	487
Configuring the 3GPP R12 GTP-C Polling Parameter Interval	488
Associating the 3GPP R12 Load Control Profile with a P-GW, SAEGW, or S-GW Service.	488
Verifying the 3GPP R12 Load Control Configuration	489
Saving the Configuration	490
Creating and Configuring a 3GPP R12 GTP-C Overload Control Profile	490
Configuration Overview	490
Creating the GTP R12 Overload Control Profile	490
Configuring 3GPP R12 Overload Control Weightage Settings	491
Configuring the 3GPP R12 Overload Control Inclusion Frequency	491
Configuring the 3GPP R12 Overload Control Validity Period	492
Configuring 3GPP R12 Overload Control Tolerance Limits	492
Configuring 3GPP R12 Overload Control Throttling Behavior	493
Configuring 3GPP R12 Overload Control Message Prioritization	494
Configuring 3GPP R12 Overload Control Self-Protection Behavior	494
Configuring 3GPP R12 Overload Control Information Handling	495
Configuring 3GPP R12 Overload Control Information Publishing	495

- Configuring the 3GPP R12 GTP-C Polling Parameter Interval 495
- Associating the 3GPP R12 Overload Control Configuration with a P-GW, SAEGW, or S-GW Service 496
- Verifying the 3GPP R12 Overload Control Configuration 497
- Saving the 3GPP R12 Overload Control Configuration 497
- Monitoring and Troubleshooting the 3GPP R12 GTP-C Load and Overload Control Feature 497
 - 3GPP R12 GTP-C Load and Overload Show Commands 498
 - show egtpc statistics egtp-service <egtp-service name> 498
 - show gtpc-load-control-profile full all 498
 - show gtpc-load-control-profile full name <name> 498
 - show gtpc-overload-control-profile full all 498
 - show gtpc-overload-control full name <name> 498
 - show pgw-service all 498
 - show sgw-service all 498
 - eGTP-C Bulk Statistics 498

CHAPTER 23

Gx Interface Support 499

- Rel. 7 Gx Interface 499
 - Introduction 500
 - Supported Networks and Platforms 502
 - License Requirements 502
 - Supported Standards 502
 - Terminology and Definitions 502
 - Policy Control 503
 - Charging Control 507
 - Policy and Charging Control (PCC) Rules 508
 - PCC Procedures over Gx Reference Point 510
 - Volume Reporting Over Gx 512
 - How Rel. 7 Gx Works 516
 - Configuring Rel. 7 Gx Interface 519
 - Configuring IMS Authorization Service at Context Level 520
 - Applying IMS Authorization Service to an APN 522
 - Configuring Volume Reporting over Gx 523
 - Gathering Statistics 523

Rel. 8 Gx Interface	524
HA/PDSN Rel. 8 Gx Interface Support	524
Introduction	525
Terminology and Definitions	527
How it Works	534
Configuring HA/PDSN Rel. 8 Gx Interface Support	537
Gathering Statistics	539
P-GW Rel. 8 Gx Interface Support	540
Introduction	540
Terminology and Definitions	541
Rel. 9 Gx Interface	545
P-GW Rel. 9 Gx Interface Support	545
Introduction	545
Terminology and Definitions	546
3GPP Rel.9 Compliance for IPFilterRule	550
Rel. 10 Gx Interface	553
P-GW Rel. 10 Gx Interface Support	553
Introduction	553
Terminology and Definitions	553
Supported Gx Features	560
Assume Positive for Gx	560
Default Policy on CCR-I Failure	561
Gx Back off Functionality	562
Support for Volume Reporting in Local Policy	562
Support for Session Recovery and Session Synchronization	563
Configuring Gx Assume Positive Feature	563
Time Reporting Over Gx	565
License Requirements	565
Feature Overview	565
Usage Monitoring	566
Usage Reporting	567
Configuring Time Reporting over Gx	568
Support for Multiple Active and Standby Gx Interfaces to PCRF	568
Configuring Diameter Peer Selection at Database in Failure Scenarios	569

Support for Multiple CCR-Us over Gx Interface	569
Configuring Gateway Node to Support Back-to-Back CCR-Us	570
Support for RAN/NAS Cause IE on Gx Interface	571
Configuring Supported Feature Netloc-RAN-NAS-Cause	571
Support ADC Rules over Gx Interface	571
Limitations	572
Configuring ADC Rules over Gx	573
GoR Name Support in TDF-Application-Identifier	573
ADC Mute Customization	574
Support for TAI and ECGI Change Reporting	577
Feature Description	577
How it Works	578
Monitoring and Troubleshooting the TAI and ECGI Change Reporting Feature	579
Location Based Local-Policy Rule Enforcement	579
Feature Description	580
How it Works	580
Configuring Location Based Local Policy Rule Enforcement Feature	582
Monitoring and Troubleshooting the Location Based LP Rule Enforcement Feature	584
Gx Support for GTP based S2a/S2b	585
Gx-based Virtual APN Selection	585
Feature Description	585
Configuring Gx based Virtual APN Selection Feature	586
Monitoring and Troubleshooting the Gx based Virtual APN Selection	586
Graceful Handling of RAR from Different Peers	587
NetLoc Feature Enhancement	588
Feature Description	588
Command Changes	592
Performance Indicator Changes	592
RAN-NAS Cause Code Feature Enhancement	593
Feature Description	593
Command Changes	597
Session Disconnect During Diamproxy-Session ID Mismatch	597
Feature Description	597
Configuring System to Delete Diamproxy-Session ID Mismatched Sessions	598

Monitoring and Troubleshooting the Mismatched Session Deletion Feature	599
Support for Negotiating Mission Critical QCIs	599
Feature Description	600
Configuring DPCA for Negotiating Mission Critical QCIs	600
Monitoring and Troubleshooting the Mission Critical QCI	601
HSS and PCRF-based P-CSCF Restoration Support for WLAN	601
Feature Description	602
Configuring the HSS/PCRF-based P-CSCF Restoration	603
Monitoring and Troubleshooting the HSS/PCRF-based P-CSCF Restoration	604
Loop Prevention for Dynamic Rules	606
Feature Information	606
Feature Description	607
How It Works	607
Configuring Loop Prevention for Dynamic Rules	607
Monitoring and Troubleshooting	608
Separation of Accounting Interim Interval Timer for RADIUS and Diameter Rf	609
Feature Information	609
Feature Description	609
How It Works	610
Configuring Diameter Accounting Interim Interval	611
Monitoring and Troubleshooting	611
Enhancement to OCS Failure Reporting for Gy	612
Feature Information	612
Feature Description	613
Support Added for RAN/NAS Cause Code for S5/S8 and S2b Interfaces	613
Feature Information	613
Feature Changes	614
Command Changes	618

CHAPTER 24

Gx Support for eMPS	619
Feature Summary and Revision History	619
Feature Description	620
Relationships to Other Features	621
How It Works	621

- Limitations 622
- Configuring Gx Support for eMPS 622
 - Configuring eMPS Profile 622
 - Enabling Gx Prioritization for eMPS Sessions 622
 - Enabling GTP Prioritization for eMPS Sessions under GTP Load Overload Throttling 623
 - Verifying the Gx Support for eMPS Configuration 624
- Monitoring and Troubleshooting the Gx Support for eMPS 624
 - show ims-authorization policy-control statistics 624

CHAPTER 25

Gy Interface Support 625

- Feature Summary and Revision History 625
- Introduction 626
 - License Requirements 627
 - Supported Standards 628
- Features and Terminology 628
 - Charging Scenarios 628
 - Session Charging with Reservation 628
 - Basic Operations 629
 - Re-authorization 629
 - Threshold based Re-authorization Triggers 630
 - Termination Action 630
 - Diameter Base Protocol 630
 - Diameter Credit Control Application 631
 - Quota Behavior 631
 - Supported AVPs 644
 - Unsupported AVPs 647
 - PLMN and Time Zone Reporting 652
 - Interworking between Session-based Gy and Event-based Gy 653
 - OCS Unreachable Failure Handling Feature 653
 - Enhancement to OCS Failure Reporting for Gy 655
 - Feature Description 655
 - Addition of Server Unreachable Field in CDR 655
 - Feature Description 655
 - Adding Server Unreachable Field in CDR 657

Monitoring and Troubleshooting	657
Backpressure Handling	658
Gy Backpressure Enhancement	658
Gy Support for GTP based S2a/S2b	659
Generating OOC/ROC with Changing Association between Rule and RG	659
Static Rulebase for CCR	659
CC based Selective Gy Session Control	660
Feature Description	660
Configuring CC based Selective Gy Session Control	661
Monitoring and Troubleshooting the Selective Gy Session Control Feature	662
Credit-Control Group in Rulebase Configuration	662
Feature Description	662
Configuring Credit-Control Group in Rulebase	663
Monitoring and Troubleshooting the CC-Group Selection in Rulebase	664
Combined CCR-U Triggering for QoS Change Scenarios	664
Re-activating Offline Gy Session after Failure	665
Feature Description	665
Configuring Offline Gy Session after Failure	666
Monitoring and Troubleshooting the Offline Gy Session after Failure	666
Suppress AVPs	667
Feature Description	667
Command Changes	667
Performance Indicator Changes	668
Configuring Gy Interface Support	668
Configuring GGSN / P-GW / IPSG Gy Interface Support	668
Configuring HA / PDSN Gy Interface Support	669
Configuring PLMN and Time Zone Reporting	671
Configuring Server Unreachable Feature	672
Configuring Static Rulebase for CCR	673
Configuring Gy for GTP based S2a/S2b	673
Gathering Statistics	673

Feature Description	676
How It Works	676
Configuring Gy Failure Handling	677
Monitoring and Troubleshooting the Gy Failure Handling	677
Gy Failure Handling Show Command(s) and/or Outputs	677

CHAPTER 27**HSS and PCRF Based P-CSCF Restoration Support 679**

Feature Description	679
Limitations	680
Licensing	680
How It Works	680
Call Flows	682
Standards Compliance	688
Configuring the HSS/PCRF-based P-CSCF Restoration	689
Enabling P-CSCF Restoration Indication on S6b AAA Interface	689
Enabling P-CSCF Restoration Indication on Gx Interface	689
Enabling P-CSCF Restoration for Emergency PDNs	690
Enabling Re-Auth After S6b Triggered P-CSCF Restoration of WLAN	690
Verifying the HSS/PCRF-based P-CSCF Restoration	691
Monitoring and Troubleshooting the HSS/PCRF-based P-CSCF Restoration	691
Output of Show Commands	692
Monitoring Logs	694
Bulk Statistics	695

CHAPTER 28**ICAP Interface Support 697**

ICAP Interface Support Overview	697
Supported Networks and Platforms	699
License Requirements	699
Failure Action on Retransmitted Packets	699
ICAP Client Communication with RFC 3507 compliance	700
Configuring ICAP Interface Support	702
Creating ICAP Server Group and Address Binding	703
Configuring ICAP Server and Other Parameters	703
Configuring ECS Rulebase for ICAP Server Group	704

Configuring Charging Action for ICAP Server Group	704
Verifying the ICAP Server Group Configuration	705

CHAPTER 29	Increase in Monitoring of Peers Supported Through Heartbeat Mechanism for PMIP Sessions	707
	Feature Summary and Revision History	707
	Feature Description	708
	Configuring the Increase in Number of PMIP Sessions Supported with the Heartbeat Mechanism Feature	709
	heartbeat monitor-max-peers	709
	Monitoring and Troubleshooting	710
	Show Commands and/or Outputs	710
	show lma-service all	710

CHAPTER 30	L2TP Access Concentrator	713
	Applicable Products and Relevant Sections	714
	Supported LAC Service Configurations for PDSN Simple IP	715
	Attribute-based Tunneling	715
	How The Attribute-based L2TP Configuration Works	716
	Configuring Attribute-based L2TP Support for PDSN Simple IP	717
	PDSN Service-based Compulsory Tunneling	717
	How PDSN Service-based Compulsory Tunneling Works	717
	Configuring L2TP Compulsory Tunneling Support for PDSN Simple IP	719
	Supported LAC Service Configurations for the GGSN and P-GW	719
	Transparent IP PDP Context Processing with L2TP Support	721
	Non-transparent IP PDP Context Processing with L2TP Support	722
	PPP PDP Context Processing with L2TP Support	723
	Configuring the GGSN or P-GW to Support L2TP	725
	Supported LAC Service Configuration for Mobile IP	725
	How The Attribute-based L2TP Configuration for MIP Works	726
	Configuring Attribute-based L2TP Support for HA Mobile IP	727
	Configuring Subscriber Profiles for L2TP Support	728
	RADIUS and Subscriber Profile Attributes Used	728
	RADIUS Tagging Support	730
	Configuring Local Subscriber Profiles for L2TP Support	730

- Configuring Local Subscriber 731
- Verifying the L2TP Configuration 731
 - Tunneling All Subscribers in a Specific Context Without Using RADIUS Attributes 731
- Feature Description 731
- Configuring LAC Services 732
 - Configuring LAC Service 732
 - Configuring Multicast Services over L2TP 733
 - Configuring LNS Peer 733
 - Verifying the LAC Service Configuration 733
- Modifying PDSN Services for L2TP Support 734
 - Modifying PDSN Service 735
 - Verifying the PDSN Service for L2TP Support 735
- Modifying APN Templates to Support L2TP 735
 - Assigning LNS Peer Address in APN Template 736
 - Configuring Outbound Authentication 736
 - Verifying the APN Configuration 736

CHAPTER 31

LBO Restriction on Downlink and Uplink Data Volume Transfer 739

- Feature Summary and Revision History 739
- Feature Description 740
- How It Works 740
 - Limitation 740
- Configuring the LBO Restriction on Downlink and Uplink Data Volume Transfer 740
 - Enabling the LBO Restriction on Downlink and Uplink Data Volume Transfer 740
- Monitoring and Troubleshooting the LBO Restriction on Downlink and Uplink Data Volume Transfer 741
 - Show Commands and/or Outputs 741

CHAPTER 32

LTE to Wi-Fi (S2bGTP) Seamless Handover 743

- Feature Summary and Revision History 743
- Feature Description 744
- How It Works 744
 - LTE to Wi-Fi Handoff 744
 - Session Recovery and ICSR 746

Configuring LTE to Wi-Fi Seamless Handover	746
Configuring LTE to Wi-Fi Handover Timer	746
Monitoring and Troubleshooting	746
Show Command(s) and/or Outputs	746
show apn statistics name <name>	746
Bulk Statistics	747
APN Schema	747
P-GW Schema	747
SAEGW Schema	747

CHAPTER 33**LTE-M RAT Type Support on SAEGW, P-GW, and S-GW Services 749**

Feature Summary and Revision History	749
Feature Description	750
How it Works	751
Architecture	751
Limitations	752
Supported Standards	752
Configuring Virtual-APN	753
Configuring qci-qos-mapping	753
Monitoring and Troubleshooting	754
Show Commands and Output	754
show apn name	754
show apn all	754
show qci-qos-mapping table all	754
show configuration	755
show subscribers full	755
show subscribers full all	756
show subs pgw-only full / show subs pgw-only full all	756
show subs sgw-only full / show subs sgw-only full all	756
show subs saegw-only full / show subs saegw-only full all	756
show subs pgw-only all	757
show subs sgw-only all	757
show subs saegw-only all	757
show subscribers callid	757

show session subsystem	757
show session subsystem verbose	758
show session summary	758
show subscribers subscription full	758
show subscribers activity all	758
show apn statistics all-name	759
show saegw-service statistics all-name	759
show pgw-service statistics all-name	759
show sgw-service statistics	759
Bulk Statistics	760
APN Schema	760
P-GW Schema	760
S-GW Schema	760
SAEGW Schema	760

CHAPTER 34	Maximum Receive Unit Configuration Support	763
	Feature Summary and Revision History	763
	Feature Description	764
	How It Works	764
	Configuring the MRU Feature	764
	Configuring MRU	764
	Verifying the Configured MRU	765

CHAPTER 35	Mobile IP Registration Revocation	767
	Overview	767
	Configuring Registration Revocation	768
	Configuring FA Services	769
	Configuring HA Services	769

CHAPTER 36	Multi-Protocol Label Switching (MPLS) Support	771
	Overview	771
	Chassis as MPLS-CE Connecting to PE	772
	Chassis as MPLS-CE Connected to ASBR	773
	Engineering Rules	773

Supported Standards	773
Supported Networks and Platforms	774
Licenses	774
Benefits	774
Configuring BGP/MPLS VPN with Static Labels	774
Create VRF with Route-distinguisher and Route-target	775
Set Neighbors and Enable VPNv4 Route Exchange	775
Configure Address Family and Redistributed Connected Routes	776
Configure IP Pools with MPLS Labels	776
Bind DHCP Service for Corporate Servers	776
Bind AAA Group for Corporate Servers	777
Configuring BGP/MPLS VPN with Dynamic Labels	777
Create VRF with Route-distinguisher and Route-target	778
Set Neighbors and Enable VPNv4 Route Exchange	779
Configure Address Family and Redistributed Connected Routes	779
Configure IP Pools with MPLS Labels	779
Bind DHCP Service for Corporate Servers	779
Bind AAA Group for Corporate Servers	780
DSCP and EXP Bit Mapping	780

CHAPTER 37

Multiple IP Versions Support	781
Feature Summary and Revision History	781
Feature Description	782
How it Works	782
Configuring Multiple IP Version Support	784
Monitoring and Troubleshooting	785
Show Commands and Outputs	785
show configuration	785
show egtp-service all	785

CHAPTER 38

NetLoc for WiFi EPC	787
Feature Description	787
How It Works	787
Accounting Requirements	788

- Limitations **788**
- Configuring the NetLoc for WiFi EPC Feature **789**
 - Configuring the NetLoc TWAN for Gx **789**
 - Configuring the NetLoc UWAN for Gx **790**
 - Configuring the NetLoc UWAN for Gy **790**
 - Configuring the NetLoc UWAN for Gz **790**
- Monitoring and Troubleshooting the NetLoc for WiFi EPC Feature **791**
 - Show Commands and/or Outputs **791**

CHAPTER 39

Network Mobility (NEMO) 793

- NEMO Overview **793**
 - Use Cases **794**
 - Features and Benefits **794**
 - MIPv4-based NEMO Control Plane **794**
 - NEMO MR Authorization **796**
 - MIPv4 NEMO Protocol **796**
 - GRE Encapsulation **796**
 - Session Interactions **796**
 - NEMO Session Timers **797**
 - Enterprise-wide Route Limit Control **797**
 - Forced Fragmentation **797**
 - Redundancy/Reliability **797**
 - LTE NEMO Call Flow **798**
 - Engineering Rules **800**
 - Supported Standards **800**
- NEMO Configuration **800**
 - Sample Configuration **801**
 - Create a VRF **802**
 - Set Neighbors and Address Family **802**
 - Redistribute Connected Routes **802**
 - Configure and Enable NEMO in APN Profile **802**
 - Create a NEMO HA **803**
 - Monitoring and Troubleshooting **803**

CHAPTER 40	NEMO PMIPv6 Heartbeat on LMA	805
	Feature Information	805
	Feature Description	806
	License Requirements	806
	Monitoring and Troubleshooting the NEMO PMIPv6 Heartbeat on LMA	807
	Show Command(s) and/or Outputs	807

CHAPTER 41	Network Service Headers (NSH)	809
	Feature Summary and Revision History	809
	Feature Description	810
	How It Works	810
	Configuring Support for NSH Framework	812
	Charging Action Association	812
	Service Chain Association	812
	Service Scheme Association	813
	NSH Configuration Mode	813
	NSH Fields Configuration Mode	814
	tag-value	814
	NSH Format Configuration Mode	815
	encode	815
	encoding-frequency	815
	decode	816
	Trigger Condition Configuration Mode Commands	816
	content-type	816
	tdf-app-id	817
	Sample Configuration for NSH Creation	818
	Show Commands and Outputs	819
	show nsh statistics	819
	show active-charging trigger-condition statistics	819

CHAPTER 42	Operator Policy	821
	What Operator Policy Can Do	821
	A Look at Operator Policy on an SGSN	821

A Look at Operator Policy on an S-GW	822
The Operator Policy Feature in Detail	822
Call Control Profile	822
APN Profile	823
IMEI-Profile (SGSN only)	824
APN Remap Table	824
Operator Policies	825
IMSI Ranges	826
How It Works	826
Operator Policy Configuration	826
Call Control Profile Configuration	827
Configuring the Call Control Profile for an SGSN	827
Configuring the Call Control Profile for an MME or S-GW	828
APN Profile Configuration	828
IMEI Profile Configuration - SGSN only	829
APN Remap Table Configuration	829
Operator Policy Configuration	830
IMSI Range Configuration	830
Configuring IMSI Ranges on the MME or S-GW	830
Configuring IMSI Ranges on the SGSN	831
Associating Operator Policy Components on the MME	831
Configuring Accounting Mode for S-GW	831
Verifying the Feature Configuration	832

CHAPTER 43
Overcharging Protection Support 833

Overcharging Protection Feature Overview	833
License	834
Configuring Overcharging Protection Feature	834
Configuring Overcharging Support on the P-GW	834
Configuring Overcharging Support on the S-GW	835
Monitoring and Troubleshooting	836
P-GW Schema	836
show apn statistics all	836
show pgw-service all	836

show pgw-service statistics all	836
show sgw-service statistics name <sgw_service_name>	836
show subscribers full	836
show subscribers pgw-only full all	837
show subscribers summary	837

CHAPTER 44**Paging Policy Differentiation 839**

Feature Description	839
Relationships	839
License	840
How It Works	840
Architecture	840
Relationships to Other Features	841
Standards Compliance	841
Configuring Paging Policy Differentiation Feature	841
Configuration	841
Monitoring and Troubleshooting Paging Policy Differentiation	842
P-GW Show Commands	843
show apn name <apn_name>	843
show subscribers pgw-only full all	843
SAEGW Show Commands	843
show subscribers saegw-only full all	843
S-GW Show Commands	843
show sgw-service name <service_name>	843

CHAPTER 45**P-GW Handoff KPIs for VoWiFi 845**

P-GW Handoff KPIs for VoWiFi	845
Feature Changes	845
Benefits	845
Limitations	846
Monitoring and Troubleshooting P-GW Handoff KPIs for VoWiFi	846
HandOff KPIS for VoWiFi Show Commands	846
Schema for P-GW Handoff KPIs for VoWiFi	847

CHAPTER 46**Presence Reporting Area 851**

- Feature Summary and Revision History 851
- Feature Description 852
- How It Works 852
- Multiple Presence Reporting Area 855
- Configuring Presence Reporting Area 856
 - Configuring PRA 856
 - Configuring Multiple-PRA 856
- Monitoring and Troubleshooting 857
 - Show Commands and Outputs 857
 - show ims-authorization service name <service-name> 857
 - show ims-authorization sessions full all 857
 - show ims-authorization service statistics 858
 - show subscribers pgw-only full all 859
 - show subs saegw-only full all 859

CHAPTER 47**Proxy-Mobile IP 861**

- Overview 861
 - Proxy Mobile IP in 3GPP2 Service 863
 - Proxy Mobile IP in 3GPP Service 863
 - Proxy Mobile IP in WiMAX Service 864
- How Proxy Mobile IP Works in 3GPP2 Network 864
 - Scenario 1: AAA server and PDSN/FA Allocate IP Address 864
 - Scenario 2: HA Allocates IP Address 866
- How Proxy Mobile IP Works in 3GPP Network 868
- How Proxy Mobile IP Works in WiMAX Network 871
 - Scenario 1: AAA server and ASN GW/FA Allocate IP Address 871
 - Scenario 2: HA Allocates IP Address 873
- How Proxy Mobile IP Works in a WiFi Network with Multiple Authentication 875
- Configuring Proxy Mobile-IP Support 881
 - Configuring FA Services 881
 - Verify the FA Service Configuration 882
 - Configuring Proxy MIP HA Failover 882

Configuring Subscriber Profile RADIUS Attributes	883
Configuring Subscriber Profile RADIUS Attributes	883
RADIUS Attributes Required for Proxy Mobile IP	883
Configuring Local Subscriber Profiles for Proxy-MIP on a PDSN	884
Configuring Local Subscriber Profiles for Proxy-MIP on a PDIF	885
Configuring Default Subscriber Parameters in Home Agent Context	885
Configuring APN Parameters	885

CHAPTER 48**Revised Marking for Subscriber Traffic 887**

Feature Summary and Revision History	887
Feature Description	888
Limitations	888
How It Works	888
Behavior Changes for Different Services	888
Configuring Revised Marking for Subscriber Traffic	889
Configuring Internal Priority	889
Verifying the Configuration	890
Configuring 802.1p and MPLS EXP Marking for User Data Traffic	890
Configure ip-dscp-iphb-mapping	890
Configure L2-mapping	891
Configure qci-qos	891
Associate L2-mapping table	892
Associate internal-qos-data in a P-GW and S-GW Service	892
Monitoring and Troubleshooting Revised Marking for Subscriber Traffic	893
Internal Priority Show Commands	893
show configuration	893
show service-type { all name service_name }	893

CHAPTER 49**Rf Interface Support 895**

Introduction	895
Offline Charging Architecture	896
Charging Collection Function	897
Charging Trigger Function	897
Dynamic Routing Agent	897

- License Requirements **898**
- Supported Standards **898**
- Feature Summary and Revision History **898**
- Features and Terminology **899**
 - Offline Charging Scenarios **899**
 - Basic Principles **899**
 - Event Based Charging **900**
 - Session Based Charging **901**
 - Diameter Base Protocol **901**
 - Timer Expiry Behavior **902**
 - Rf Interface Failures/Error Conditions **902**
 - DRA/CCF Connection Failure **902**
 - No Reply from CCF **902**
 - Detection of Message Duplication **902**
 - CCF Detected Failure **903**
 - Rf-Gy Synchronization Enhancements **903**
 - Cessation of Rf Records When UE is IDLE **904**
 - QoS Change Scenarios **904**
 - Diameter Rf Duplicate Record Generation **904**
 - Feature Description **904**
 - Configuring Rf Duplicate Record Generation **906**
 - Monitoring and Troubleshooting the Rf Duplicate Record Generation **908**
 - Truncation of Virtual APN for Rf Records **908**
 - Feature Description **908**
 - Configuring Virtual APN Truncation for Rf Records **909**
 - Monitoring and Troubleshooting the Virtual APN Truncation **911**
 - Accounting Record Stop Location Report **911**
- How it Works **912**
- Configuring Rf Interface Support **914**
 - Enabling Rf Interface in Active Charging Service **915**
 - Configuring GGSN / P-GW Rf Interface Support **915**
 - Configuring P-CSCF/S-CSCF Rf Interface Support **922**
 - Gathering Statistics **922**

CHAPTER 50	Routing Behind the Mobile Station on an APN	925
	Feature Description	925
	How It Works	925
	Routing Behind the Mobile Station on an APN	925
	Configuring Routing Behind the Mobile Station	926
	Configuration Overview	926
	Creating an APN Profile	926
	Enabling Routing Behind the Mobile Station	927
	Verifying the Routing Behind the Mobile Station	927
	Monitoring and Troubleshooting the Routing Behind the Mobile Station	930
	Routing Behind the Mobile Station Show Command(s) and/or Outputs	930
	show apn name <apn_name>	930

CHAPTER 51	Routing Based on Realm Name S6B	931
	Summary Data	931
	Overview of Routing Based on Realm P-GW	932
	How it Works	932
	Enabling Realm for S6b Interface	932

CHAPTER 52	Secondary RAT Usage Report in CDR Records	935
	Feature Summary and Revision History	935
	Feature Description	936
	Behavior Matrix	936
	Relationship to Other Features	938
	Limitations	938
	Configuring Secondary RAT Usage Report through GTPP	939
	Enabling or Disabling the Secondary RAT Usage Report	939
	Controlling the Maximum Number of Entries	939
	Suppressing Zero-Volume Secondary RAT Usage Report	942
	Monitoring and Troubleshooting	942
	Show Commands and Outputs	942
	show config	942
	show config verbose	943

show gtp group 943
 show gtp statistics group 943

CHAPTER 53 **Separation of 2G, 3G, and 4G Bulkstatistics 945**

- Feature Summary and Revision History 945
- Feature Description 946
- Configuring RAT types in Stats Profile 946
 - Sample Configuration 946
- Monitoring and Troubleshooting 947
 - Show Commands and Outputs 947
 - show apn statistics all 947
 - show gtp statistics 948
 - show stats profile all 948
 - Bulk Statistics 948

CHAPTER 54 **Session Tracing 951**

- Session Tracing Overview 951
 - Session Trace Types 952
 - Session Trace Activation 953
 - Session Trace Deactivation 953
 - Data Collection 954
 - Data Forwarding 954
 - Supported Standards 954
- Configuring Session Trace Functionality 955
 - Enabling Session Tracing 955
 - Verifying that Session Tracing is Enabled 956
 - Disabling Session Trace Functionality 956
 - Configuring a Session Trace Template for the Management Trace Function 956
 - Verifying the Session Trace Template Configuration 959
 - Disabling the Session Trace Template Configuration 959
 - Disabling the Session Trace Template Configuration per Network Element and Subscriber 960
- Configuring a Management Session Trace 960
 - Verifying the Management Trace Configuration 961
 - Disabling the Management Trace Configuration 961

Configuring a Signaling Session Trace	961
Verifying the Signaling Session Trace Configuration	962
Disabling the Signaling Session Trace	962
Configuring a Random Trace	962
Verifying the Random Trace Configuration	965
Disabling the Random Trace for a Specific Network Element	965
Monitoring the Session Trace Functionality	965
Supported SAEGW Session Trace Configurations	966
Session Trace File Example	969

CHAPTER 55**S-GW Event Reporting 973**

S-GW Event Reporting	973
Event Record Triggers	973
Event Record Elements	974
Active-to-Idle Transitions	976
3GPP 29.274 Cause Codes	976

CHAPTER 56**S-GW Paging Enhancements 979**

Feature Description	979
Licensing	980
How It Works	980
High Priority DDN at S-GW	980
MBR-DDN Collision Handling	981
Limitations	981
Configuring High Priority DDN Interaction Feature	982
Configuring mbr-guard-timer	982
Verifying the Configuration	983
Monitoring and Troubleshooting High Priority DDN Interaction Feature	983
Show Commands for High Priority DDN Interaction Feature	983
show sgw-service [name <service-name> all]	983
show sgw-service statistics all	984
show saegw-service statistics all function sgw	985

CHAPTER 57**S-GW Restoration Support 987**

- Feature Description 987
 - Relationships to Other Features 988
- How it Works 988
 - Changes at P-GW 988
 - Changes at the E-GTPC 988
 - Changes at the MME and SGSN 988
 - Demux Failure Detection 989
 - Standards Compliance 989
- Configuring S-GW Restoration Support 989
 - Sample Configuration 990
 - Verifying the S-GW Configuration 990
- Monitoring and Troubleshooting S-GW Restoration Support 990
 - S-GW Show Commands 990
 - show ims-authorization policy-control statistics 990
 - show pgw-service statistics all 991
 - show subscribers pgw-only full all 991

CHAPTER 58

Support for One Million S1-U Peer-to-Peer Connections 993

- Feature Description 993
- How it Works 993
 - Recovery/ICSR Considerations 994
 - Configuration and Restrictions 994
- Configuring the Feature 994
 - gtpu peer statistics threshold 994
- Show Command Output 995
 - clear gtpu statistics peer-address 995
 - show gtpu statistics 995
 - show session subsystem facility sessmgr 995

CHAPTER 59

Support for Presence Reporting Area and Extended QOS on Offline Charging Interface for P-GW and SAEGW 997

- Feature Summary and Revision History 997
- Feature Description 998
 - Handling Single and Multi-Presence Reporting Area on Rf Interface 998

Behavior Matrix	999
Configuring IMS Authorization Service at Context Level	1001
Configuring AAA Group	1002

CHAPTER 60**Traffic Policing and Shaping 1003**

Feature Description	1003
Traffic Policing	1003
Traffic Shaping	1004
Traffic Policing Configuration	1004
Configuring Subscribers for Traffic Policing	1005
Configuring APN for Traffic Policing in 3GPP Networks	1006
Traffic Shaping Configuration	1007
Configuring Subscribers for Traffic Shaping	1007
Configuring APN for Traffic Shaping in 3GPP Networks	1008
Configuring Traffic Shaping	1009
Configuring Subscribers for Traffic Shaping	1009
Configuring APN for Traffic Shaping in 3GPP Networks	1010
RADIUS Attributes	1012
Traffic Policing for CDMA Subscribers	1012
Traffic Policing for UMTS Subscribers	1013

CHAPTER 61**Type of Service/Traffic Class Configuration for Predefined Rules 1015**

Feature Summary and Revision History	1015
Feature Description	1016
How It Works	1016
Limitations	1017
Configuring the TOS/Traffic Class for Predefined Rules	1017
Enabling or Disabling the ip tos-traffic-class Command	1017
Monitoring and Troubleshooting	1018
Show Commands	1018
show configuration	1018
show active-charging packet-filter	1018
show configuration verbose	1019

APPENDIX A

S-GW Engineering Rules 1021

- Interface and Port Rules 1021
- Assumptions 1021
- S1-U/S11 Interface Rules 1022
- S5/S8 Interface Rules 1022
- MAG to LMA Rules 1022
- S-GW Service Rules 1022
- S-GW Subscriber Rules 1023

APPENDIX B

P-GW Engineering Rules 1025

- Interface and Port Rules 1025
- S2a Interface Rules 1025
- LMA to MAG 1025
- S5/S8 Interface Rules (GTP) 1026
- P-GW Context and Service Rules 1026
- P-GW Subscriber Rules 1026



About this Guide



Note Control and User Plane Separation (CUPS) represents a significant architectural change in the way StarOS-based products are deployed in the 3G, 4G, and 5G networks. Unless otherwise specified, it should not be assumed that any constructs (including, but not limited to, commands, statistics, attributes, MIB objects, alarms, logs, services) referenced in this document imply functional parity with CUPS products. References to any CUPS products or features are for informational purposes only. Please contact your Cisco Account or Support representative for any questions about parity between this product and any CUPS products.



Note The documentation set for this product strives to use bias-free language. For purposes of this documentation set, bias-free is defined as language that does not imply discrimination based on age, disability, gender, racial identity, ethnic identity, sexual orientation, socioeconomic status, and intersectionality. Exceptions may be present in the documentation due to language that is hardcoded in the user interfaces of the product software, language used based on RFP documentation, or language that is used by a referenced third-party product.



Note The HA, HSGW, PDSN, and SecGW products have reached end of life and are not supported in this release. Any references to these products (specific or implied) their components or functions including CLI commands and parameters in this document are coincidental and are not supported. Full details on the end of life for these products are available at <https://www.cisco.com/c/en/us/products/collateral/wireless/asr-5000-series/eos-eol-notice-c51-740422.html>.

This preface describes the Serving Architecture Evolution Gateway (SAEGW) Administration Guide, how it is organized and its document conventions.

The SAEGW node is a combination of S-GW and P-GW nodes. SAEGW operates as a service on the StarOS and requires existing S-GW and P-GW services to be configured and mentioned inside an SAEGW service configuration. Existing standalone S-GW and P-GW services (when part of an SAEGW umbrella service) will work in tandem to present a single SAEGW node as a black-box view. This document contains feature descriptions, configuration procedures, and monitoring and troubleshooting information.

- [Conventions Used, on page i](#)
- [Supported Documents and Resources, on page li](#)

Conventions Used

The following tables describe the conventions used throughout this documentation.

Notice Type	Description
Information Note	Provides information about important features or instructions.
Caution	Alerts you of potential damage to a program, device, or system.
Warning	Alerts you of potential personal injury or fatality. May also alert you of potential electrical hazards.

Typeface Conventions	Description
Text represented as a <code>screen display</code>	This typeface represents displays that appear on your terminal screen, for example: <code>Login:</code>
Text represented as commands	This typeface represents commands that you enter, for example: show ip access-list This document always gives the full form of a command in lowercase letters. Commands are not case sensitive.
Text represented as a command variable	This typeface represents a variable that is part of a command, for example: show card <i>slot_number</i> <i>slot_number</i> is a variable representing the desired chassis slot number.
Text represented as menu or sub-menu names	This typeface represents menus and sub-menus that you access within a software application, for example: Click the File menu, then click New

Command Syntax Conventions	Description
{ keyword or <i>variable</i> }	<p>Required keyword options and variables are those components that are required to be entered as part of the command syntax.</p> <p>Required keyword options and variables are surrounded by grouped braces { }. For example:</p> <pre>sctp-max-data-chunks { limit max_chunks mtu-limit }</pre> <p>If a keyword or variable is not enclosed in braces or brackets, it is mandatory. For example:</p> <pre>snmp trap link-status</pre>
[keyword or <i>variable</i>]	<p>Optional keywords or variables, or those that a user may or may not choose to use, are surrounded by brackets.</p>
	<p>Some commands support multiple options. These are documented within braces or brackets by separating each option with a vertical bar.</p> <p>These options can be used in conjunction with required or optional keywords or variables. For example:</p> <pre>action activate-flow-detection { intitiation termination }</pre> <p>or</p> <pre>ip address [count number_of_packets size number_of_bytes]</pre>

Supported Documents and Resources

Related Common Documentation

The most up-to-date information for this product is available in the product Release Notes provided with each product release.

The following common documents are available:

- AAA Interface Administration Reference
- Command Line Interface Reference
- GTPP Interface Administration Reference
- Hardware Installation Guide (hardware dependent)
- Release Change Reference
- Statistics and Counters Reference
- System Administration Guide (hardware dependent)

- Thresholding Configuration Guide

Related Product Documentation

The following product documents are also available and work in conjunction with the SAEGW:

- ADC Administration Guide
- ECS Administration Guide
- GGSN Administration Guide
- MME Administration Guide
- NAT Administration Guide
- PSF Administration Guide
- P-GW Administration Guide
- S-GW Administration Guide

Obtaining Documentation

The most current Cisco documentation is available on the following website:

<http://www.cisco.com/cisco/web/psa/default.html>

Use the following path selections to access the SAE-GW documentation:

Products > Wireless > Mobile Internet > Network Functions > Cisco SAEGW System Architecture Evolution Gateway

Contacting Customer Support

Use the information in this section to contact customer support.

Refer to the support area of <http://www.cisco.com> for up-to-date product documentation or to submit a service request. A valid username and password are required to access this site. Please contact your Cisco sales or service representative for additional information.



CHAPTER 1

SAE Gateway Overview

The Cisco® ASR 5500 provides wireless carriers with a flexible solution that functions as a System Architecture Evolution (SAE) Gateway with Packet Data Network (PDN) Gateway (P-GW) and Serving Gateway (S-GW) functions in LTE-SAE (3GPP2 Long Term Evolution-System Architecture Evolution) wireless data networks.

This overview provides general information about the SAEGW including:

- [SAEGW Product Description, on page 1](#)
- [S-GW Product Description, on page 3](#)
- [P-GW Product Description, on page 5](#)
- [S-GW Network Deployment\(s\), on page 8](#)
- [P-GW Network Deployment\(s\), on page 14](#)
- [S-GW Features and Functionality - Base Software, on page 29](#)
- [P-GW Features and Functionality - Base Software, on page 54](#)
- [P-GW Features and Functionality - Inline Service Support, on page 100](#)
- [S-GW Features and Functionality - Optional Enhanced Feature Software, on page 105](#)
- [P-GW Features and Functionality - Optional Enhanced Feature Software, on page 114](#)
- [How the Serving Gateway Works, on page 134](#)
- [How the PDN Gateway Works, on page 138](#)
- [S-GW Supported Standards, on page 147](#)
- [P-GW Supported Standards, on page 151](#)

SAEGW Product Description

The SAEGW node is a combination of S-GW and P-GW nodes. SAEGW operates as a service on ASR5500 and requires existing S-GW and P-GW services to be configured and mentioned inside SAEGW service configuration. Existing standalone S-GW and P-GW services (when part of an SAEGW umbrella service) will work in tandem to present a single SAEGW node as a black-box view.

The SAEGW supports all of the interfaces that the standalone S-GW and P-GW products support, namely:

- S11/S4 – GTPv2 based control interface towards MME/S4-SGSN
- S1U/S12/S4U – GTPv1 based data interface towards eNodeB/RNC/S4-SGSN
- S5/S8 – GTPv2 based control interface between S-GW and P-GW
- Gi – Data interface towards packet data network

- Gx – Diameter based interface between P-GW and PCRF
- S6b – Diameter based interface between P-GW and HSS
- Rf – Diameter based offline charging interface between P-GW/S-GW and charging data function
- Gy – GTPP based online charging interface between P-GW and online charging system
- Gz – GTPP based offline charging interface between P-GW/S-GW and charging gateway function



Important In StarOS releases 19 and later, the Rf interface is not supported on the S-GW.

Mode of operation is described as the functionality performed by SAEGW for a call. Granularity for mode of operation is per-PDN. The SAEGW service supports the following three modes of operation:

- S+P Collapsed: When a UE is using S-GW part of SAEGW and a PDN connection is terminating within the P-GW part of SAEGW.
- Pure-S: When a UE is using S-GW part of SAEGW and a PDN connection is terminating at an external P-GW not part of SAEGW.
- Pure-P: When a UE is using an external S-GW not part of SAEGW and a PDN connection is terminating within P-GW part of SAEGW.



Important For a given UE with multiple PDNs, SAEGW will be able to support S+P mode for some PDNs while Pure-S mode for others.



Important SAEGW supports change of operation-mode in life of a PDN. For example, a PDN initially doing S+P mode may change to doing Pure-P if S-GW gets relocated to external S-GW that is not part of SAEGW. Similarly, a PDN doing Pure-P mode may change to S+P mode if S-GW relocated so that new S-GW is part of SAEGW service.

An optimized SAEGW provides the following benefits:

- **Higher Capacity**

A UE with one PDN connection that passes through standalone S-GW and P-GW services consumes two license units because both S-GW and P-GW services account for it separately. SAEGW as a single node consumes only one license unit for the same, thus increasing the capacity. Contact your Cisco account representative for detailed information on product licensing.

- **Cohesive Configuration**

Configuration and management of SAEGW as a node is easier to follow than starting standalone S-GW and P-GW services.

Platform Requirements

The SAEGW service runs on a Cisco® ASR 5500 Series chassis running StarOS. The chassis can be configured with a variety of components to meet specific network deployment requirements. For additional information, refer to the *Installation Guide* for the chassis and/or contact your Cisco account representative.

Licenses

The SAEGW is a licensed Cisco product. Separate session and feature licenses may be required. Contact your Cisco account representative for detailed information on specific licensing requirements. For information on installing and verifying licenses, refer to the *Managing License Keys* section of the *Software Management Operations* chapter in the *System Administration Guide*.

S-GW Product Description

The Serving Gateway routes and forwards data packets from the UE and acts as the mobility anchor during inter-eNodeB handovers. Signals controlling the data traffic are received on the S-GW from the MME which determines the S-GW that will best serve the UE for the session. Every UE accessing the EPC is associated with a single S-GW.

Figure 1: S-GW in the Basic E-UTRAN/EPC Network

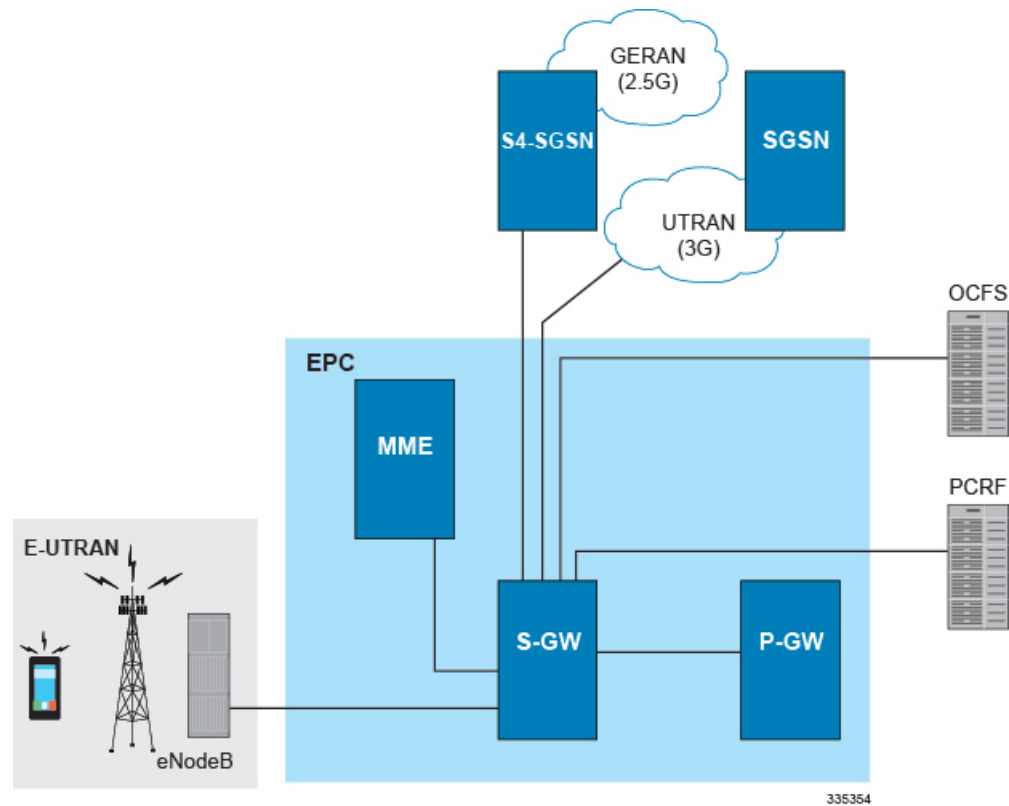

The S-GW is also involved in mobility by forwarding down link data during a handover from the E-UTRAN to the eHRPD network. An interface from the eAN/ePCF to an MME provides signaling that creates a GRE tunnel between the S-GW and the eHRPD Serving Gateway.

Figure 2: S-GW in the Basic E-UTRAN/EPC and eHRPD Network

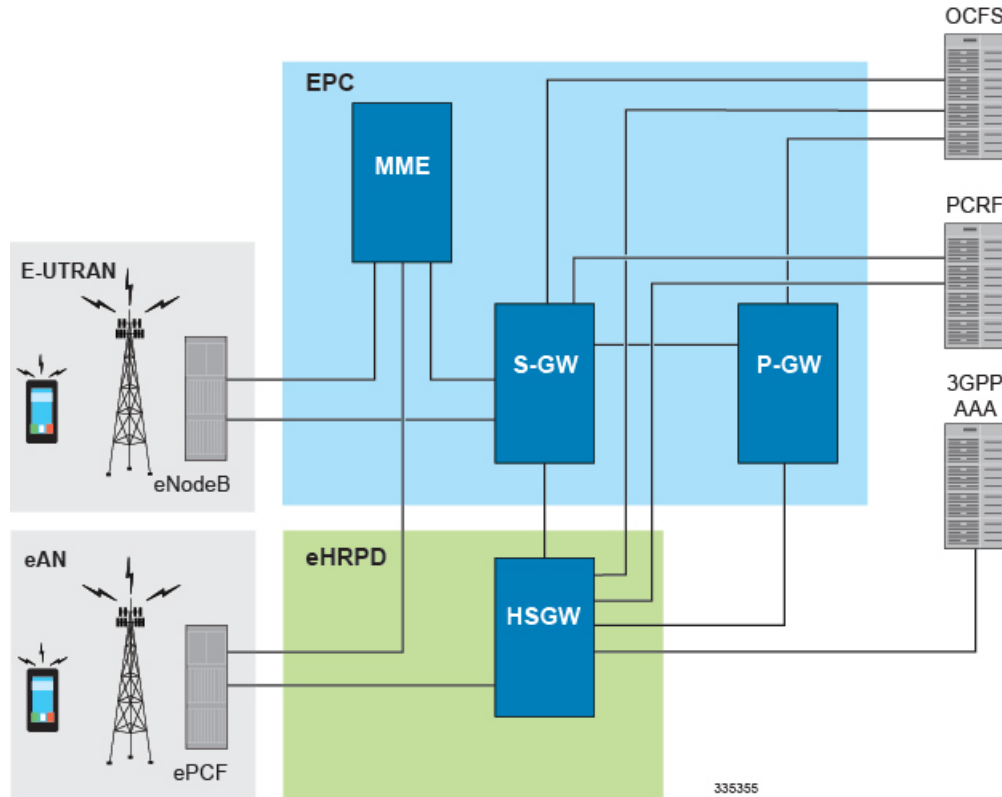

The functions of the S-GW include:

- packet routing and forwarding.
- providing the local mobility anchor (LMA) point for inter-eNodeB handover and assisting the eNodeB reordering function by sending one or more "end marker" packets to the source eNodeB immediately after switching the path.
- mobility anchoring for inter-3GPP mobility (terminating the S4 interface from an SGSN and relaying the traffic between 2G/3G system and a PDN gateway).
- packet buffering for ECM-IDLE mode downlink and initiation of network triggered service request procedure.
- replicating user traffic in the event that Lawful Interception (LI) is required.
- transport level packet marking.
- user accounting and QoS class indicator (QCI) granularity for charging.
- uplink and downlink charging per UE, PDN, and QCI.
- reporting of user location information (ULI).

- support of circuit switched fallback (CSFB) for re-using deployed CS domain access for voice and other CS domain services.

Platform Requirements

The S-GW service runs on a Cisco® ASR 5500 Series chassis running StarOS. The chassis can be configured with a variety of components to meet specific network deployment requirements. For additional information, refer to the *Installation Guide* for the chassis and/or contact your Cisco account representative.

Licenses

The S-GW is a licensed Cisco product covered by the SAEGW license when part of an SAEGW umbrella service. Separate session and feature licenses may be required. Contact your Cisco account representative for detailed information on specific licensing requirements. For information on installing and verifying licenses, refer to the *Managing License Keys* section of the *Software Management Operations* chapter in the *System Administration Guide*.

P-GW Product Description

The P-GW is the node that terminates the SGi interface towards the PDN. If a UE is accessing multiple PDNs, there may be more than one P-GW for that UE. The P-GW provides connectivity to the UE to external packet data networks by being the point of exit and entry of traffic for the UE. A UE may have simultaneous connectivity with more than one P-GW for accessing multiple PDNs. The P-GW performs policy enforcement, packet filtering for each user, charging support, lawful interception and packet screening.

Figure 3: P-GW in the Basic E-UTRAN/EPC Network

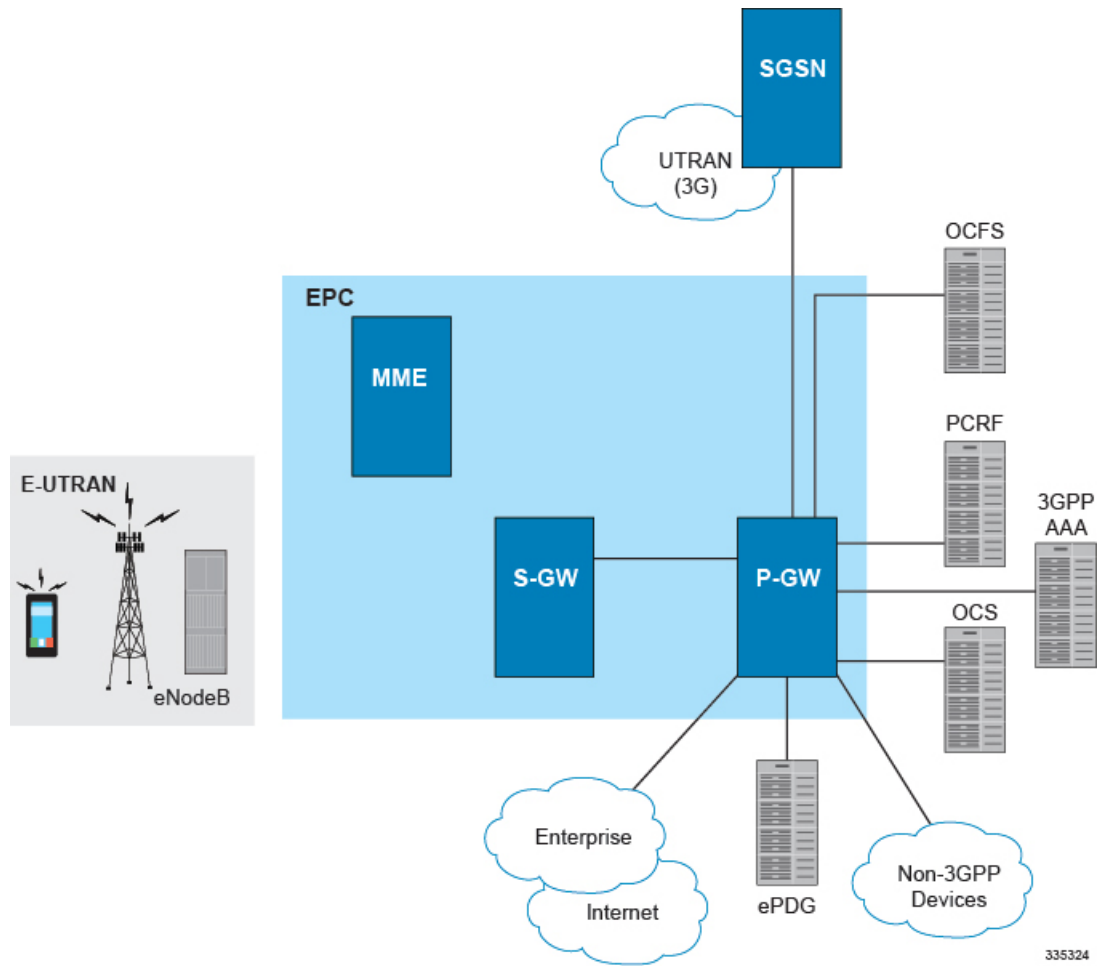
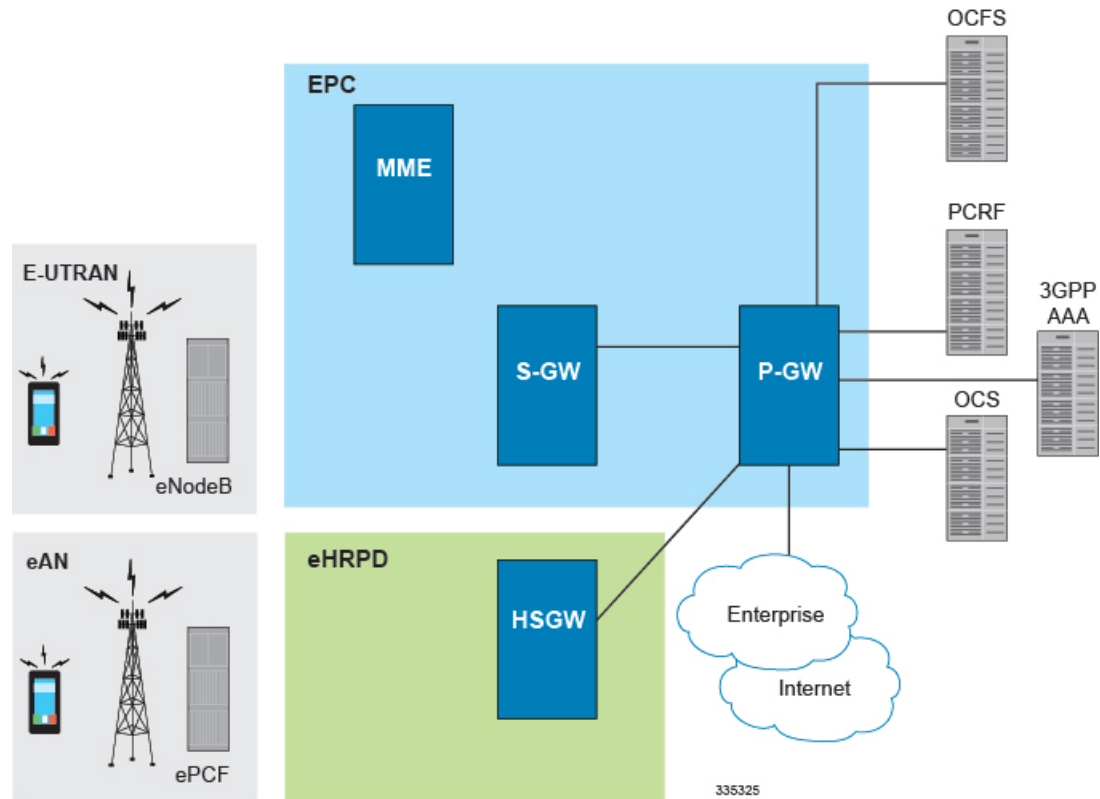

Figure 4: P-GW in the Basic E-UTRAN/EPC and eHRPD Network



Another key role of the P-GW is to act as the anchor for mobility between 3GPP and non-3GPP technologies such as WiMAX and 3GPP2 (CDMA 1X and EvDO).

P-GW functions include:

- Mobility anchor for mobility between 3GPP access systems and non-3GPP access systems. This is sometimes referred to as the SAE Anchor function.
- Policy enforcement (gating and rate enforcement)
- Per-user based packet filtering (deep packet inspection)
- Charging support
- Lawful Interception
- UE IP address allocation
- Packet screening
- Transport level packet marking in the downlink;
- Down link rate enforcement based on Aggregate Maximum Bit Rate (AMBR)

The following are additional P-GW functions when supporting non-3GPP access (eHRPD):

- P-GW includes the function of a Local Mobility Anchor (LMA) according to draft-ietf-netlmm-proxymip6, if PMIP-based S5 or S8 is used.

- The P-GW includes the function of a DSMIPv6 Home Agent, as described in draft-ietf-mip6-nemo-v4traversal, if S2c is used.

Platform Requirements

The P-GW service runs on a Cisco® ASR 5500 chassis running StarOS. The chassis can be configured with a variety of components to meet specific network deployment requirements. For additional information, refer to the Installation Guide for the chassis and/or contact your Cisco account representative.

Licenses

The P-GW is a licensed Cisco product covered by the SAEGW license when part of an SAEGW umbrella service. Separate session and feature licenses may be required. Contact your Cisco account representative for detailed information on specific licensing requirements. For information on installing and verifying licenses, refer to the *Managing License Keys* section of the *Software Management Operations* chapter in the *System Administration Guide*.

S-GW Network Deployment(s)

This section describes the supported interfaces and the deployment scenarios of a Serving Gateway.

Serving Gateway in the E-UTRAN/EPC Network

The following figure displays the specific network interfaces supported by the S-GW. Refer to [Supported Logical Network Interfaces \(Reference Points\)](#), on page 10 for detailed information about each interface.

Figure 5: Supported S-GW Interfaces in the E-UTRAN/EPC Network

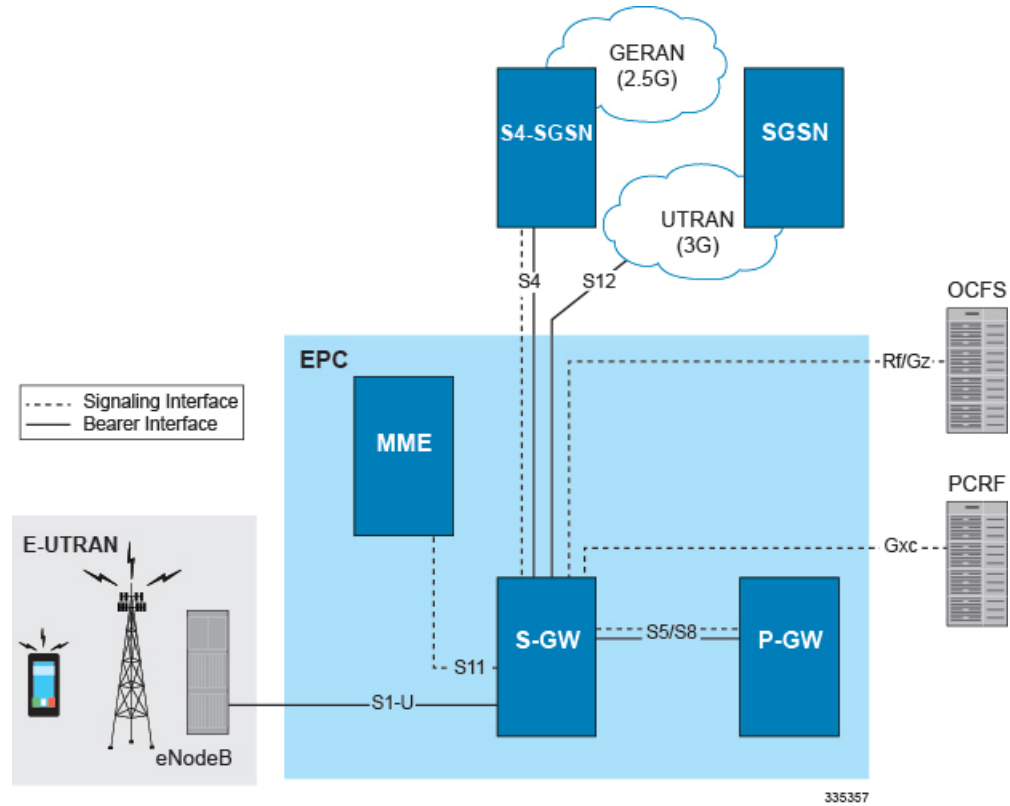

The following figure displays a sample network deployment of an S-GW, including all of the interface connections with other 3GPP Evolved-UTRAN/Evolved Packet Core network devices.

Figure 6: S-GW in the E-UTRAN/EPC Network

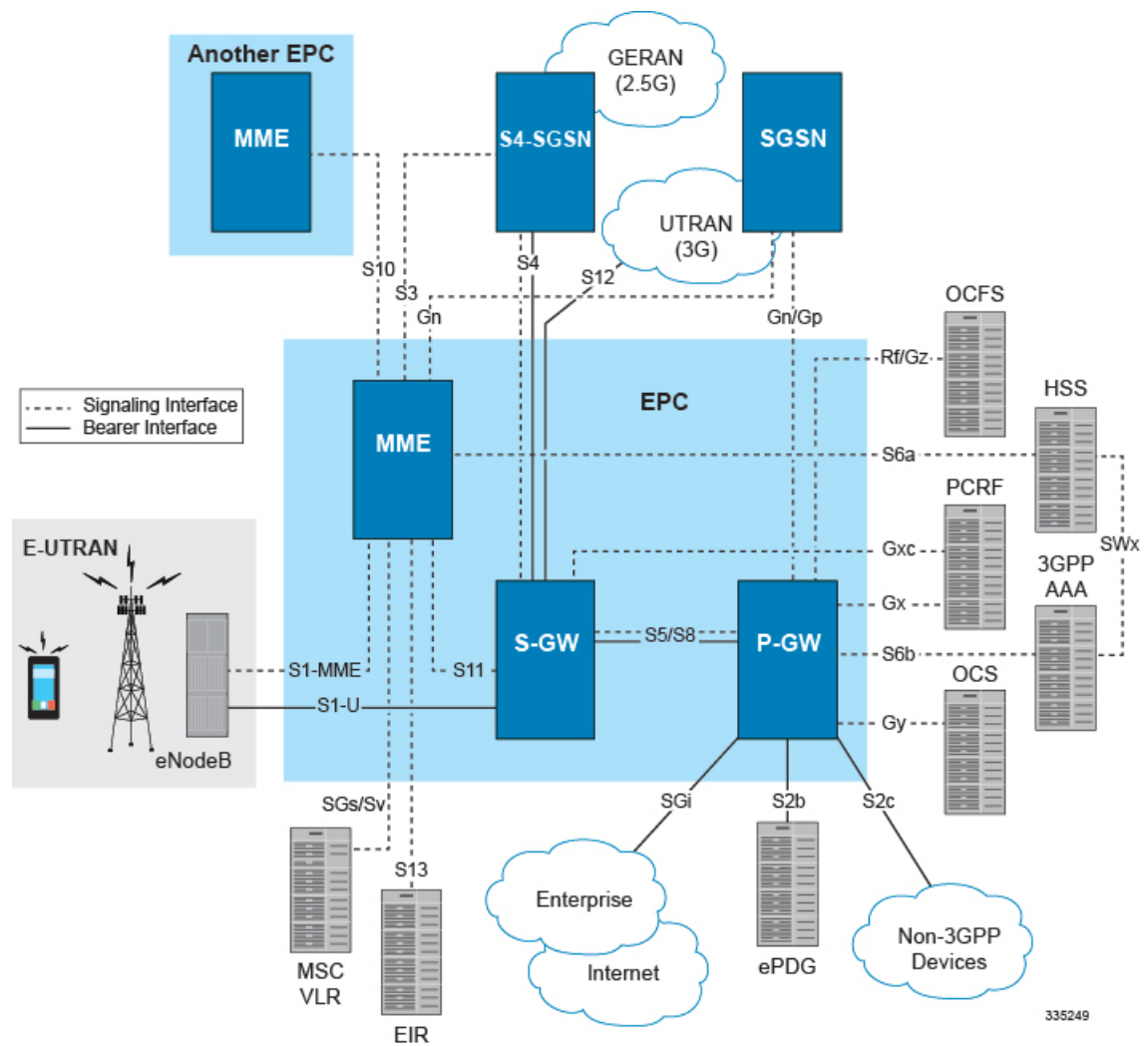

Supported Logical Network Interfaces (Reference Points)

The S-GW provides the following logical network interfaces in support of the E-UTRAN/EPC network:

S1-U Interface

This reference point provides bearer channel tunneling between the eNodeB and the S-GW. It also supports eNodeB path switching during handovers. The S-GW provides the local mobility anchor point for inter-eNodeB hand-overs. It provides inter-eNodeB path switching during hand-overs when the X2 handover interface between base stations cannot be used. The S1-U interface uses GPRS tunneling protocol for user plane (GTP-Uv1). GTP encapsulates all end user IP packets and it relies on UDP/IP transport. The S1-U interface also supports IPsec IKEv2. This interface is defined in 3GPP TS 23.401.

Supported protocols:

- Transport Layer: UDP, TCP
- Tunneling: IPv4 or IPv6 GTPv1-U (bearer channel)

- Network Layer: IPv4, IPv6
- Data Link Layer: ARP
- Physical Layer: Ethernet

Figure 7: Protocols Supported on the S1-U Interface

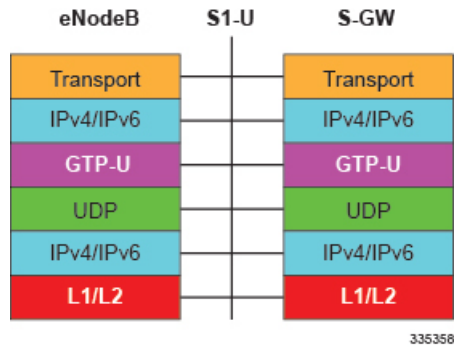

S4 Interface

This reference point provides tunneling and management between the S-GW and a 3GPP S4 SGSN. The interface facilitates soft hand-offs with the EPC network by providing control and mobility support between the inter-3GPP anchor function of the S-GW. This interface is defined in 3GPP TS 23.401.

Supported protocols:

- Transport Layer: UDP
- Tunneling:
 - GTP: IPv4 or IPv6 GTP-C (GTPv2 control/signaling channel) and GTP-U (GTPv1 user/bearer channel)
- Network Layer: IPv4, IPv6
- Data Link Layer: ARP
- Physical Layer: Ethernet

Figure 8: Protocols Supported on the S4 Interface

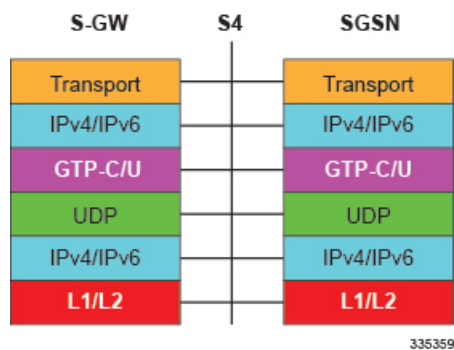

S5/S8 Interface

This reference point provides tunneling and management between the S-GW and the P-GW, as defined in 3GPP TS 23.401. The S8 interface is an inter-PLMN reference point between the S-GW and the P-GW used during roaming scenarios. The S5 interface is used between an S-GW and P-GW located within the same

administrative domain (non-roaming). It is used for S-GW relocation due to UE mobility and if the S-GW needs to connect to a non-located P-GW for the required PDN connectivity.

Supported protocols:

- Transport Layer: UDP, TCP
- Tunneling: GTP: GTPv2-C (signaling channel), GTPv1-U (bearer channel)
- Network Layer: IPv4, IPv6
- Data Link Layer: ARP
- Physical Layer: Ethernet

Figure 9: Supported Protocols on the S5/S8 Interface

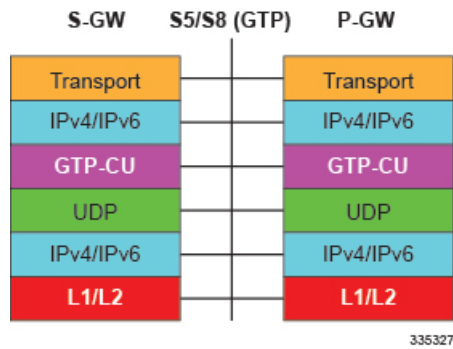

S11 Interface

This reference point provides GTP-C control signal tunneling between the MME and the S-GW. One GTP-C tunnel is created for each mobile terminal between the MME and S-GW. This interface is defined in 3GPP TS 23.401.

Supported protocols:

- Transport Layer: UDP
- Tunneling: IPv4 or IPv6 GTPv2-C (signaling channel)
- Network Layer: IPv4, IPv6
- Data Link Layer: ARP
- Physical Layer: Ethernet

Figure 10: Supported Protocols on the S11 Interface

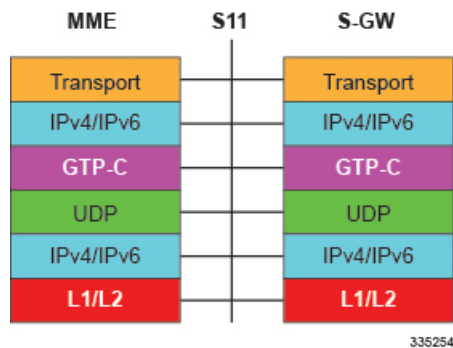

S12 Interface

This reference point provides GTP-U bearer/user direct tunneling between the S-GW and a UTRAN Radio Network Controller (RNC), as defined in 3GPP TS 23.401. This interface provides support for inter-RAT handovers between the 3G RAN and EPC allowing a direct tunnel to be initiated between the RNC and S-GW, thus bypassing the S4 SGSN and reducing latency.

Supported protocols:

- Transport Layer: UDP
- Tunneling: IPv4 or IPv6 GTP-U (GTPv1 bearer/user channel)
- Network Layer: IPv4, IPv6
- Data Link Layer: ARP
- Physical Layer: Ethernet

Figure 11: Supported Protocols on the S12 Interface

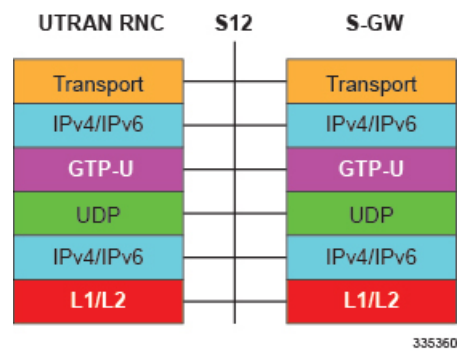

Gz Interface

The Gz reference interface enables offline accounting functions on the S-GW. The S-GW collects charging information for each mobile subscriber UE pertaining to the radio network usage. The Gz interface and offline accounting functions are used primarily in roaming scenarios where the foreign P-GW does not support offline charging.

Supported protocols:

- Transport Layer: TCP
- Network Layer: IPv4, IPv6
- Data Link Layer: ARP
- Physical Layer: Ethernet

Figure 12: Protocols Supported on the Gz Interface

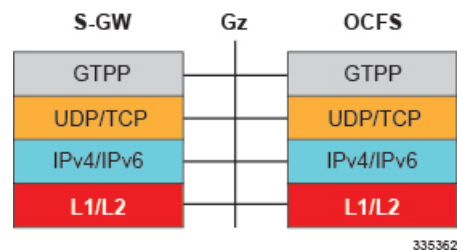

Rf Interface



Important In StarOS releases 19 and later, the Rf interface is not supported on the S-GW.

The Diameter Rf interface (3GPP 32.240) is used for offline (post-paid) charging between the Charging Trigger Function (CTF, S-GW) and the Charging Data Function (CDF). It follows the Diameter base protocol state machine for accounting (RFC 3588) and includes support for IMS specific AVPs (3GPP TS 32.299)

Supported protocols:

- Transport Layer: TCP or SCTP
- Network Layer: IPv4, IPv6
- Data Link Layer: ARP
- Physical Layer: Ethernet

Figure 13: Protocols Supported on the Rf Interface

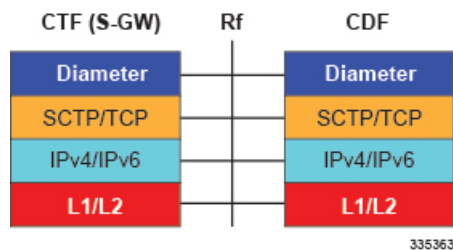

Note The Rf interface is not supported on the S-GW.

P-GW Network Deployment(s)

This section describes the supported interfaces and the deployment scenarios of a PDN Gateway.

PDN Gateway in the E-UTRAN/EPC Network

The following figure displays the specific network interfaces supported by the P-GW. Refer to [Supported Logical Network Interfaces \(Reference Points\)](#), on page 16 for detailed information about each interface.

Figure 14: Supported P-GW Interfaces in the E-UTRAN/EPC Network

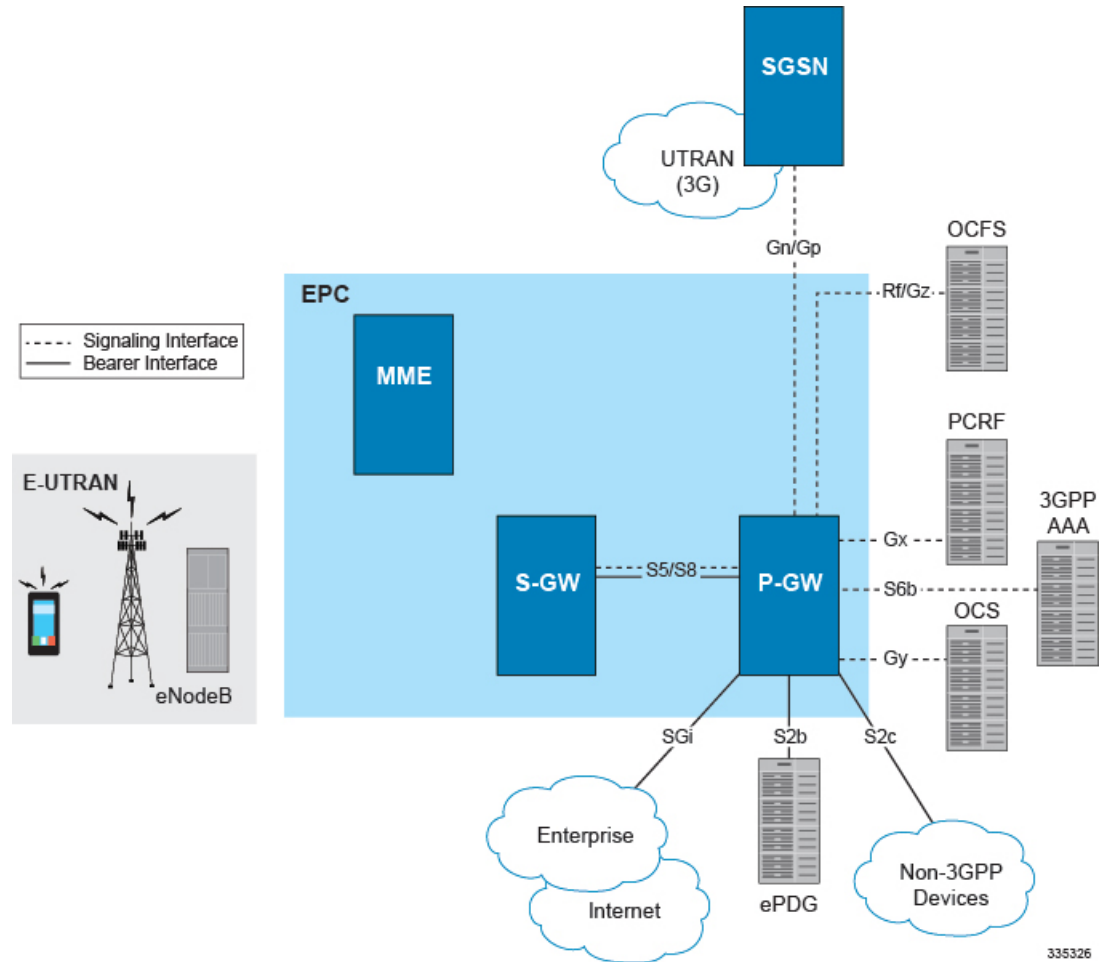

The following figure displays a sample network deployment of a P-GW, including all of the interface connections with other 3GPP Evolved-UTRAN/Evolved Packet Core network devices.

Figure 15: P-GW in the E-UTRAN/EPC Network

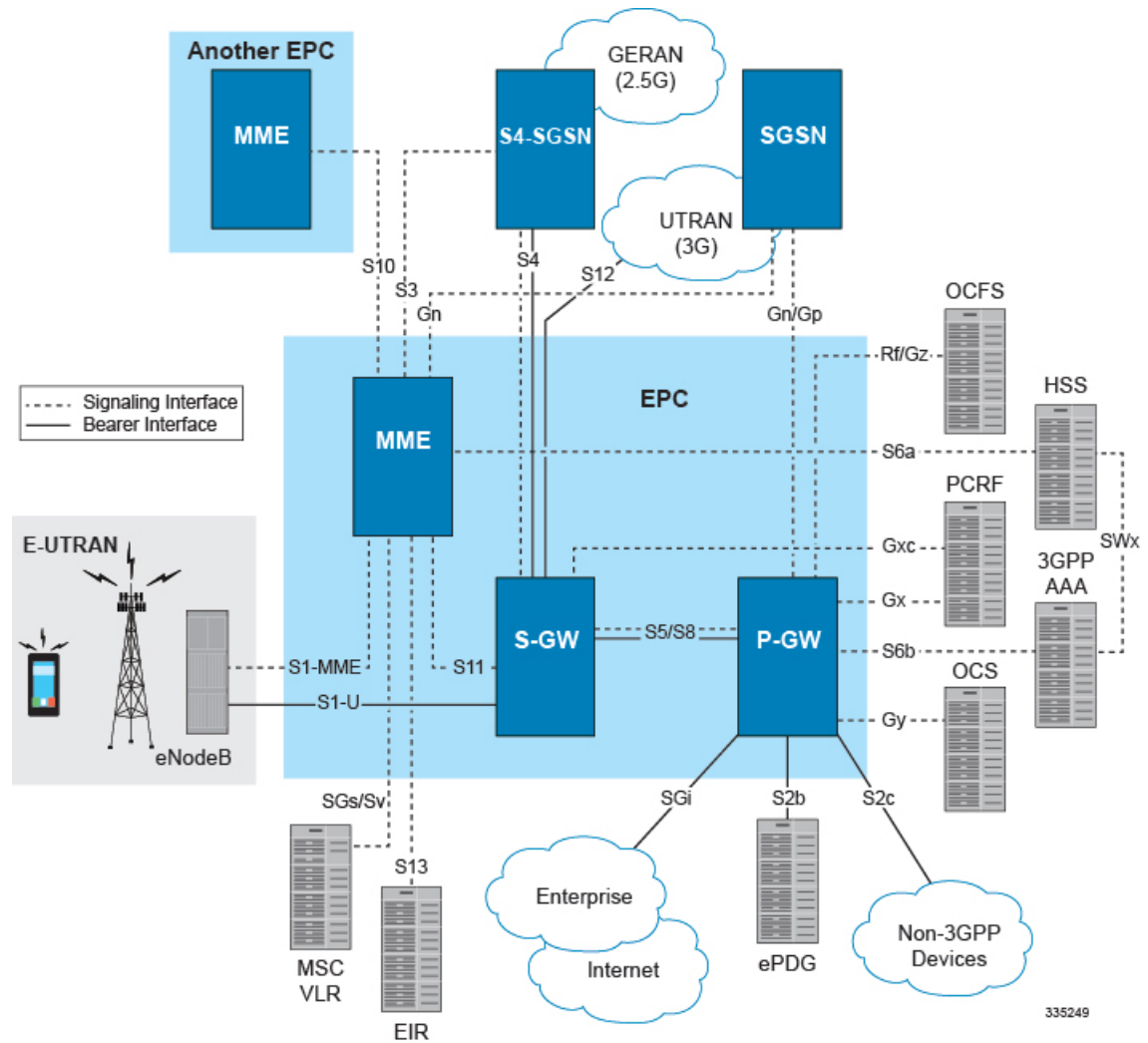

Supported Logical Network Interfaces (Reference Points)

The P-GW provides the following logical network interfaces in support of E-UTRAN/EPC network:

S5/S8 Interface

This reference point provides tunneling and management between the S-GW and the P-GW, as defined in 3GPP TS 23.401 and TS 23.402. The S8 interface is an inter-PLMN reference point between the S-GW and the P-GW used during roaming scenarios. The S5 interface is used between an S-GW and P-GW located within the same administrative domain (non-roaming). It is used for S-GW relocation due to UE mobility and if the S-GW needs to connect to a non-collocated P-GW for the required PDN connectivity.

Supported protocols

- Transport Layer: UDP, TCP
- Tunneling:

- GTP: GTPv2-C (signaling channel), GTPv1-U (bearer channel)
- Network Layer: IPv4, IPv6
- Data Link Layer: ARP
- Physical Layer: Ethernet

Figure 16: Supported GTP P-GW Protocols on the S5/S8 Interface

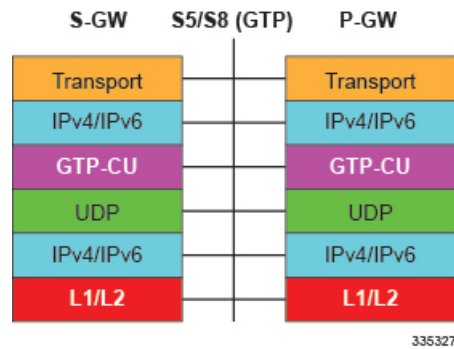
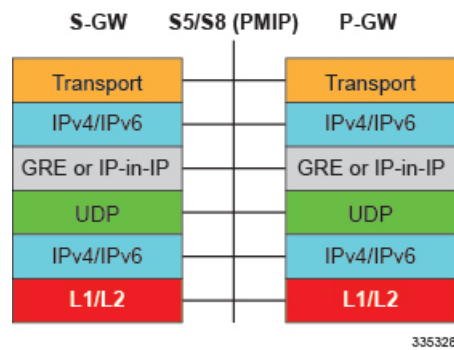

Figure 17: Supported PMIP P-GW Protocols on the S5/S8 Interface



S6b Interface

This reference point, between a P-GW and a 3GPP AAA server/proxy, is used for mobility-related authentication. It may also be used to retrieve and request parameters related to mobility and to retrieve static QoS profiles for UEs (for non-3GPP access) in the event that dynamic PCC is not supported.

The S6b interface is enhanced to pass on the UE assigned IPv6 address (IPv6 prefix and IPv6 interface ID) to the AAA server. S6b interface also has support for Framed-IPv6-Pool, Framed IP Pool, and served party IP address AVPs based IP allocation. With this support, based on the Pool name and APN name received from AAA server, the selection of a particular IP pool from the configuration is made for assigning the IP address.

The S6b interface on the P-GW or GGSN can be manually disabled to stop all message traffic to the 3GPP AAA during overload conditions. When the interface is disabled, the system uses locally configured APN-specific parameters including: Framed-Pool, Framed-IPv6-Pool, Idle-Timeout, Charging-Gateway-Function-Host, Server-Name (P-CSCF FQDN). This manual method is used when the HSS/3GPP AAA is in overload condition to allow the application to recover and mitigate the impact to subscribers

The IPv6 address reporting through Authorization-Authentication-Request (AAR) towards the S6b interface is no longer a default feature. It is now configurable through the CLI.

Another enhancement on S6b interface support is the new S6b retry-and-continue functionality that creates an automatic trigger in the GGSN and P-GW to use the locally configured APN profile upon receipt of any uniquely defined Diameter error code on the S6b interface for an Authorization-Authentication-Request (AA-R) only. This procedure would be utilized in cases where a protocol, transient, or permanent error code is returned from the both the primary and secondary AAA to the GGSN or P-GW. In case of retry-and-continue functionality, P-GW should query from DNS server if it is configured in APN. S6b failure handling continues the data call. This behavior is only applicable to the aaa-custom15 Diameter dictionary.

P-GW supports receiving AVP "Restoration-Priority-Indicator" from AAA server over the S6b interface to distinguish between VoLTE enabled IMS PDN connections and non-VoLTE enabled IMS PDN connections. KPIs are also provided based on the AVP value.



Important The S6b interface can be disabled via the CLI in the event of a long-term AAA outage.

Supported protocols:

- Transport Layer: TCP, SCTP
- Network Layer: IPv4, IPv6
- Data Link Layer: ARP
- Physical Layer: Ethernet

Figure 18: Supported Protocols on the S6b Interface

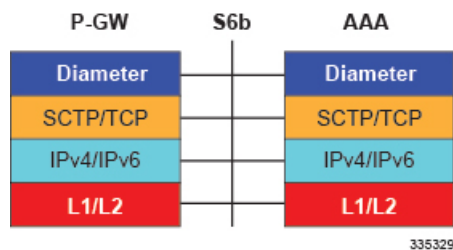

SGi Interface

This reference point provides connectivity between the P-GW and a packet data network (3GPP TS 23.401). This interface can provide access to a variety of network types including an external public or private PDN and/or an internal IMS service provisioning network.

Supported protocols:

- Transport Layer: TCP, UDP
- Network Layer: IPv4, IPv6
- Data Link Layer: ARP
- Physical Layer: Ethernet

Figure 19: Protocols Supported on the SGi Interface

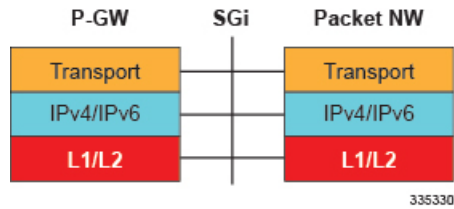

Gx Interface

This signaling interface supports the transfer of policy control and charging rules information (QoS) between the Policy and Charging Enforcement Function (PCEF) on the P-GW and a Policy and Charging Rules Function (PCRF) server (3GPP TS 23.401).

Supported protocols:

- Transport Layer: TCP, SCTP
- Network Layer: IPv4, IPv6
- Data Link Layer: ARP
- Physical Layer: Ethernet

Figure 20: Protocols Supported on the Gx Interface

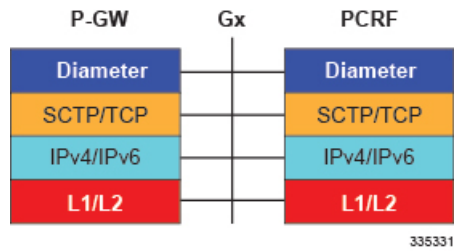

For more information on the Gx interface, refer to the [Dynamic Policy Charging Control \(Gx Reference Interface\)](#), on page 66 in the *P-GW Features and Functionality - Base Software* section of this chapter.

Gy Interface

The Gy reference interface enables online accounting functions on the P-GW in accordance with 3GPP Release 8 and Release 9 specifications.

Supported protocols:

- Transport Layer: TCP
- Network Layer: IPv4, IPv6
- Data Link Layer: ARP
- Physical Layer: Ethernet

Figure 21: Protocols Supported on the Gy Interface

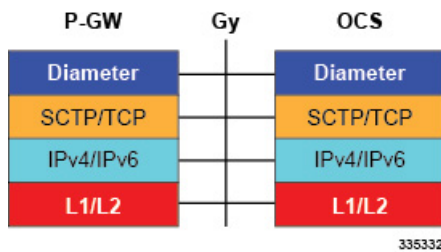

For more information on the Gy interface and online accounting, refer to [Gy Interface Support](#), on page 71 in the *P-GW Features and Functionality - Base Software* section of this chapter.

Gz Interface

The Gz reference interface enables offline accounting functions on the P-GW. The P-GW collects charging information for each mobile subscriber UE pertaining to the radio network usage.

Supported protocols:

- Transport Layer: TCP
- Network Layer: IPv4, IPv6
- Data Link Layer: ARP
- Physical Layer: Ethernet

Figure 22: Protocols Supported on the Gz Interface

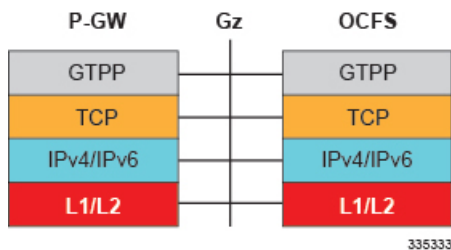

Gn/Gp Interface

This reference point provides tunneling and management between the P-GW and the SGSN during handovers between the EPS and 3GPP 2G and/or 3G networks (3GPP TS 29.060). For more information on the Gn/Gp interface, refer to [Gn/Gp Handoff Support](#), on page 73 in the *P-GW Features and Functionality - Base Software* section of this chapter.

Supported protocols

- Transport Layer: UDP, TCP
- Tunneling: GTP: GTP-C (signaling channel)
- Network Layer: IPv4, IPv6
- Data Link Layer: ARP
- Physical Layer: Ethernet

Figure 23: Protocols Supported on the Gn/Gp Interface

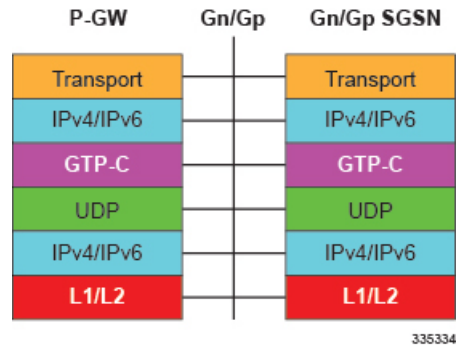

Rf Interface

The Rf interface enables offline accounting functions on the P-GW in accordance with 3GPP Release 8 and Release 9 specifications. The P-GW collects charging information for each mobile subscriber UE pertaining to the radio network usage.

Supported protocols:

- Transport Layer: TCP
- Network Layer: IPv4, IPv6
- Data Link Layer: ARP
- Physical Layer: Ethernet

Figure 24: Protocols Supported on the Rf Interface

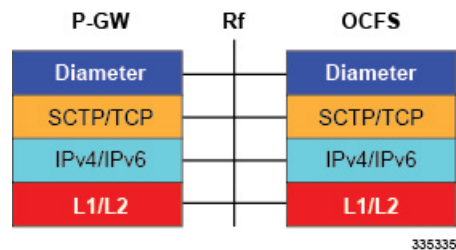

PDN Gateway Supporting eHRPD to E-UTRAN/EPC Connectivity

The following figure displays the specific network interfaces supported by the P-GW in an eHRPD network. Refer to [Supported Logical Network Interfaces \(Reference Points\)](#), on page 25 for detailed information about each interface.

Figure 25: P-GW Interfaces Supporting eHRPD to E-UTRAN/EPC Connectivity

The following figure displays a sample network deployment of a P-GW in an eHRPD Network, including all of the interface connections with other 3GPP Evolved-UTRAN/Evolved Packet Core network devices.

Figure 26: P-GW in the E-UTRAN/EPC Network Supporting the eHRPD Network

Supported Logical Network Interfaces (Reference Points)

The P-GW provides the following logical network interfaces in support of eHRPD to E-UTRAN/EPC connectivity:

S5/S8 Interface

This reference point provides tunneling and management between the S-GW and the P-GW, as defined in 3GPP TS 23.401. The S8 interface is an inter-PLMN reference point between the S-GW and the P-GW used during roaming scenarios. The S5 interface is used between an S-GW and P-GW located within the same administrative domain (non-roaming). It is used for S-GW relocation due to UE mobility and if the S-GW needs to connect to a non-collocated P-GW for the required PDN connectivity.

Supported protocols:

- Transport Layer: UDP, TCP
- Tunneling:
 - GTP: IPv4 or IPv6 GTP-C (signaling channel) and GTP-U (bearer channel)
- Network Layer: IPv4, IPv6
- Data Link Layer: ARP
- Physical Layer: Ethernet

Figure 27: Protocols Supported on the GTP P-GW S5/S8 Interface

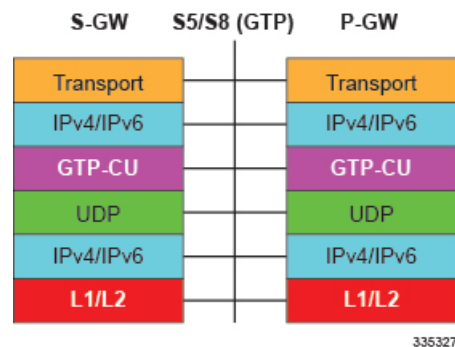

S2a Interface

This reference point supports the bearer interface by providing signaling and mobility support between a trusted non-3GPP access point (HSGW) and the PDN Gateway. It is based on Proxy Mobile IP but also supports Client Mobile IPv4 FA mode which allows connectivity to trusted non-3GPP IP access points that do not support PMIP.

Supported protocols:

- Transport Layer: UDP, TCP
- Tunneling: GRE IPv6
- Network Layer: IPv4, IPv6
- Data Link Layer: ARP

- Physical Layer: Ethernet

Figure 28: Protocols Supported on the S2a Interface

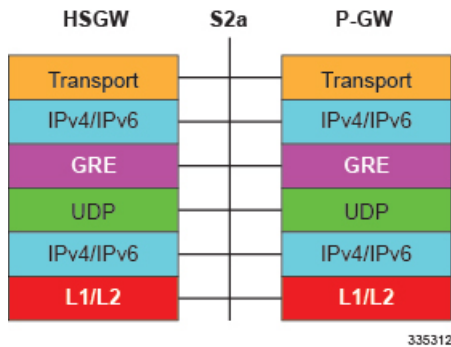

S6b Interface

This reference point, between a P-GW and a 3GPP AAA server/proxy, is used for mobility-related authentication. It may also be used to retrieve and request parameters related to mobility and to retrieve static QoS profiles for UEs (for non-3GPP access) in the event that dynamic PCC is not supported.

From Release 12.2 onwards, the S6b interface has been enhanced to pass on the UE assigned IPv6 address (IPv6 prefix and IPv6 interface ID) to the AAA server. S6b interface also has support for Framed-IPv6-Pool, Framed IP Pool, and served party IP address AVPs based IP allocation. With this support, based on the Pool name and APN name received from AAA server, the selection of a particular IP pool from the configuration is made for assigning the IP address.

The S6b interface on the P-GW or GGSN can be manually disabled to stop all message traffic to the 3GPP AAA during overload conditions. When the interface is disabled, the system uses locally configured APN-specific parameters including: Framed-Pool, Framed-IPv6-Pool, Idle-Timeout, Charging-Gateway-Function-Host, Server-Name (P-CSCF FQDN). This manual method is used when the HSS/3GPP AAA is in overload condition to allow the application to recover and mitigate the impact to subscribers.

Release 12.3 onwards, the IPv6 address reporting through Authorization-Authentication-Request (AAR) towards the S6b interface is no longer a default feature. It is now configurable through the CLI.

Another enhancement on S6b interface support is the new S6b retry-and-continue functionality that creates an automatic trigger in the GGSN and P-GW to use the locally configured APN profile upon receipt of any uniquely defined Diameter error code on the S6b interface for an Authorization-Authentication-Request (AA-R) only. This procedure would be utilized in cases where a protocol, transient, or permanent error code is returned from the both the primary and secondary AAA to the GGSN or P-GW. In case of retry-and-continue functionality, P-GW should query from DNS server if it is configured in APN. S6b failure handling continues the data call. This behavior is only applicable to the aaa-custom15 Diameter dictionary.



Important The S6b interface can be disabled via the CLI in the event of a long-term AAA outage.

Supported protocols:

- Transport Layer: TCP, SCTP
- Network Layer: IPv4, IPv6

- Data Link Layer: ARP
- Physical Layer: Ethernet

Figure 29: Protocols Supported on the S6b Interface

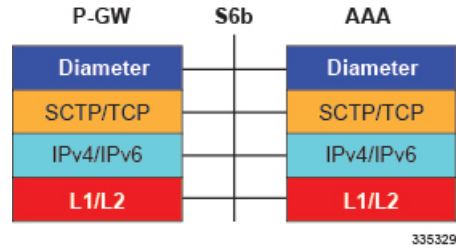

SGi Interface

This reference point provides connectivity between the P-GW and a packet data network. This interface can provide access to a variety of network types including an external public or private PDN and/or an internal IMS service provisioning network.

Supported protocols:

- Transport Layer: TCP, UDP
- Network Layer: IPv4, IPv6
- Data Link Layer: ARP
- Physical Layer: Ethernet

Figure 30: Protocols Supported on the SGi Interface

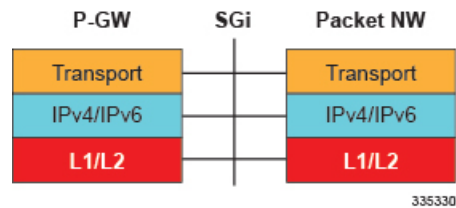

Gx Interface

This signaling interface supports the transfer of policy control and charging rules information (QoS) between the Policy and Charging Enforcement Function (PCEF) on the P-GW and a Policy and Charging Rules Function (PCRF) server (3GPP TS 23.401).

Supported protocols:

- Transport Layer: TCP, SCTP
- Network Layer: IPv4, IPv6
- Data Link Layer: ARP
- Physical Layer: Ethernet

Figure 31: Protocols Supported on the Gx Interface

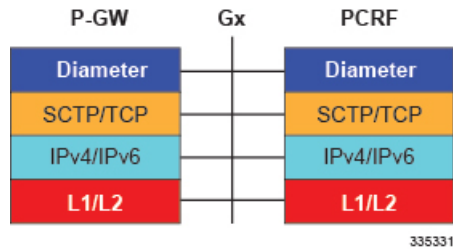

For more information on the Gx interface, refer to [Dynamic Policy Charging Control \(Gx Reference Interface\)](#), on page 66 in the *P-GW Features and Functionality - Base Software* section of this chapter.

Rf Interface

The Rf reference interface enables offline accounting functions on the P-GW in accordance with 3GPP Release 8 and Release 9 specifications. The P-GW collects charging information for each mobile subscriber UE pertaining to the radio network usage.

Supported protocols:

- Transport Layer: TCP
- Network Layer: IPv4, IPv6
- Data Link Layer: ARP
- Physical Layer: Ethernet

Figure 32: Protocols Supported on the Rf Interface

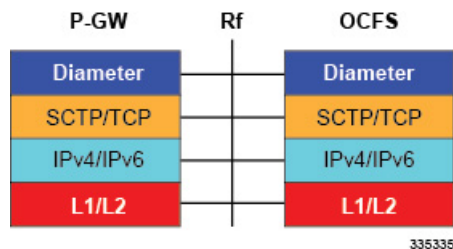

For more information on Rf accounting, refer to [Rf Diameter Accounting](#), on page 50 in the *P-GW Features and Functionality - Base Software* section of this chapter.

Gy Interface

The Gy reference interface enables online accounting functions on the P-GW in accordance with 3GPP Release 8 and Release 9 specifications.

Supported protocols:

- Transport Layer: TCP
- Network Layer: IPv4, IPv6
- Data Link Layer: ARP
- Physical Layer: Ethernet

Figure 33: Protocols Supported on the Gy Interface

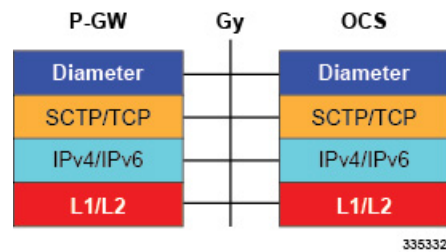

For more information on the Gy interface and online accounting, refer to [Gy Interface Support](#), on page 71 in the *P-GW Features and Functionality - Base Software* section of this chapter.

S-GW Features and Functionality - Base Software



Important The SAEGW supports all of these features if an S-GW service is assigned to the SAEGW service.

This section describes the features and functions supported by default in the base software for the S-GW service and do not require any additional licenses to implement the functionality.

3GPP Release 12 Cause-Code IE Support

When an ERAB or a data session is dropped, an operator may need to get, beyond the ULI information, detailed RAN and/or NAS release cause codes information from the access network to be included in the S-GW and P-GW CDRs for call performance analysis, User QoE analysis and proper billing reconciliation. Also, for IMS sessions, the operator may need to get the above information available at P-CSCF.

'Per E-RAB Cause' is received in ERAB Release Command and ER AB Release Indication messages over S1. However RAN and NAS causes are not forwarded to the SGW and PGW, nor provided by the PGW to PCRF.

To resolve this issue a "RAN/NAS Release Cause" information element (IE), which indicates AS and/or NAS causes, has been added to the Session Deletion Request and Delete Bearer Command. The "RAN/NAS Release Cause" provided by the MME is transmitted transparently by the S-GW to the P-GW (if there exists signaling towards P-GW) for further propagation towards the PCRF.

For backward compatibility, the S-GW can still receive the cause code from the CC IE in the S4/S11 messages and/or receive the cause code from some customers' private extension.

Abnormal Bearer Termination Cause in CDR

This feature provides additional information in a S-GW/P-GW CDR for a VoLTE call drop. A dropped bearer was previously reported as a 'abnormalrelease' in the CDR. This feature has the S-GW / P-GW CDRs indicate the proper bearer release for all failure cases identified in the VoLTE Retainability formula. This will provide the customer with the ability to perform gateway/network wide analysis for failures in the network.

New Disconnect reasons are added for GTPC/GTPU path failure and local purge GTPU error indications.

New field abnormalTerminationCause enum 83 is added in the S-GW CDR for a specific customer dictionary.

ANSI T1.276 Compliance

ANSI T1.276 specifies security measures for Network Elements (NE). In particular it specifies guidelines for password strength, storage, and maintenance security measures.

ANSI T1.276 specifies several measures for password security. These measures include:

- Password strength guidelines
- Password storage guidelines for network elements
- Password maintenance, e.g. periodic forced password changes

These measures are applicable to the ASR 5500 Platform and an element management system since both require password authentication. A subset of these guidelines where applicable to each platform will be implemented. A known subset of guidelines, such as certificate authentication, are not applicable to either product. Furthermore, the platforms support a variety of authentication methods such as RADIUS and SSH which are dependent on external elements. ANSI T1.276 compliance in such cases will be the domain of the external element. ANSI T1.276 guidelines will only be implemented for locally configured operators.

APN-level Traffic Policing

The S-GW now supports traffic policing for roaming scenarios where the foreign P-GW does not enforce traffic classes. Traffic policing is used to enforce bandwidth limitations on subscriber data traffic. It caps packet bursts and data rates at configured burst size and data rate limits respectively for given class of traffic.

Traffic Policing is based on RFC2698- A Two Rate Three Color Marker (trTCM) algorithm. The trTCM meters an IP packet stream and marks its packets green, yellow, or red. A packet is marked red if it exceeds the Peak Information Rate (PIR). Otherwise it is marked either yellow or green depending on whether it exceeds or doesn't exceed the Committed Information Rate (CIR). The trTCM is useful, for example, for ingress policing of a service, where a peak rate needs to be enforced separately from a committed rate.

Backup and Recovery of Key KPI Statistics

Before the Backup and Recovery of Key KPI Statistics feature was implemented, statistics were not backed up and could not be recovered after a SessMgr task restart. Due to this limitation, monitoring the KPI was a problem as the GGSN, P-GW, SAEGW, and S-GW would lose statistical information whenever task restarts occurred.

KPI calculation involves taking a delta between counter values from two time intervals and then determines the percentage of successful processing of a particular procedure in that time interval. When a SessMgr crashes and then recovers, the GGSN, P-GW, SAEGW, and S-GW lose the counter values - they are reset to zero. So, the KPI calculation in the next interval will result in negative values for that interval. This results in a dip in the graphs plotted using the KPI values, making it difficult for operations team to get a consistent view of the network performance to determine if there is a genuine issue or not.

This feature makes it possible to perform reliable KPI calculations even if a SessMgr restart occurs.



Important

For more information on Backup and Recovery of Key KPI Statistics, refer to the *Backup and Recovery of Key KPI Statistics* chapter in this guide.

Bulk Statistics Support

The system's support for bulk statistics allows operators to choose to view not only statistics that are of importance to them, but also to configure the format in which it is presented. This simplifies the post-processing of statistical data since it can be formatted to be parsed by external, back-end processors.

When used in conjunction with an element management system (EMS), the data can be parsed, archived, and graphed.

The system can be configured to collect bulk statistics (performance data) and send them to a collection server (called a receiver). Bulk statistics are statistics that are collected in a group. The individual statistics are grouped by schema. Following is a partial list of supported schemas:

- **System:** Provides system-level statistics
- **Card:** Provides card-level statistics
- **Port:** Provides port-level statistics
- **MAG:** Provides MAG service statistics
- **S-GW:** Provides S-GW node-level service statistics
- **IP Pool:** Provides IP pool statistics
- **APN:** Provides Access Point Name statistics

The system supports the configuration of up to four sets (primary/secondary) of receivers. Each set can be configured with to collect specific sets of statistics from the various schemas. Statistics can be pulled manually from the system or sent at configured intervals. The bulk statistics are stored on the receiver(s) in files.

The format of the bulk statistic data files can be configured by the user. Users can specify the format of the file name, file headers, and/or footers to include information such as the date, system host name, system uptime, the IP address of the system generating the statistics (available for only for headers and footers), and/or the time that the file was generated.

An EMS is capable of further processing the statistics data through XML parsing, archiving, and graphing.

The Bulk Statistics Server component of an EMS parses collected statistics and stores the information in its PostgreSQL database. It can also generate XML output and can send it to a Northbound NMS or an alternate bulk statistics server for further processing.

Additionally, the Bulk Statistics server can archive files to an alternative directory on the server. The directory can be on a local file system or on an NFS-mounted file system on an EMS server.



Important For more information on bulk statistic configuration, refer to the *Configuring and Maintaining Bulk Statistics* chapter in the *System Administration Guide*.

CDR Support for Including LAPI (Signaling Priority)

This feature is related to M2M support. 3GPP has added the LAPI (signaling priority) indication being sent in the GTP messages, to indicate that the PDN is a low priority bearer and thus can be treated accordingly. APN backoff timer support based on LAPI indication is not yet supported.

3GPP has also added a new AVP in CDR defined in TS 32.298 named "lowPriorityIndicator". If the S-GW receives the LAPI indicator in GTP, the SGW-CDR and generated will contain LAPI indication.

This benefit of this feature is that it provides support for carrying then LAPI attribute in SGW-CDR and PGW-CDR, so that billing system can then accordingly bill for that PDN.

Circuit Switched Fall Back (CSFB) Support

Circuit Switched Fall Back (CSFB) enables the UE to camp on an EUTRAN cell and originate or terminate voice calls through a forced switchover to the circuit switched (CS) domain or other CS-domain services (for example, Location Services (LCS) or supplementary services). Additionally, SMS delivery via the CS core network is realized without CSFB. Since LTE EPC networks were not meant to directly anchor CS connections, when any CS voice services are initiated, any PS based data activities on the EUTRAN network will be temporarily suspended (either the data transfer is suspended or the packet switched connection is handed over to the 2G/3G network).

CSFB provides an interim solution for enabling telephony and SMS services for LTE operators that do not plan to deploy IMS packet switched services at initial service launch.

The S-GW supports CSFB messaging over the S11 interface over GTP-C. Supported messages are:

- Suspend Notification
- Suspend Acknowledge
- Resume Notification
- Resume Acknowledgment

The S-GW forwards Suspend Notification messages towards the P-GW to suspend downlink data for non-GBR traffic; the P-GW then drops all downlink packets. Later, when the UE finishes with CS services and moves back to E-UTRAN, the MME sends a Resume Notification message to the S-GW which forwards the message to the P-GW. The downlink data traffic then resumes.

Closed Subscriber Group Support

The S-GW supports the following Closed Subscriber Group (CSG) Information Elements (IEs) and Call Detail Record:

- User CSG Information (UCI) IE in S5/S8
- CSG Information Reporting Action IE and functionality in S5/S8
- An SGW-CDR that includes a CSG record

Collision Counter Support in the GTP Layer

GTPv2 message collisions occur in the network when a node is expecting a particular procedure message from a peer node but instead receives a different procedure message from the peer. The SAEGW software has been enhanced so that these collisions are now tracked by statistics and handled based on a pre-defined action for each message collision type.

If the SAEGW is configured as a pure P-GW or a pure S-GW, operators will still see the respective collision statistics if they occur.

The output of the **show egtpc statistics verbose** command has been enhanced to provide information on GTPv2 message collisions, including:

- **Interface:** The interface on which the collision occurred: SGW (S4/S11), SGW (S5), or PGW (S5).
- **Old Proc (Msg Type):** Indicates the ongoing procedure at eGTP-C when a new message arrived at the interface which caused the collision. The Msg Type in brackets specifies which message triggered this ongoing procedure.
- **New Proc (Msg Type):** The new procedure and message type.
- **Action:** The pre-defined action taken to handle the collision. The action can be one of:
 - **No Collision Detected**
 - **Suspend Old:** Suspend processing of the original (old) message, process the new message, then resume old message handling.
 - **Abort Old:** Abort the original message handling and processes the new message.
 - **Reject New:** The new message is rejected, and the original (old) message is processed.
 - **Silent Drop New:** Drop the new incoming message, and the old message is processed.
 - **Parallel Hndl:** Both the original (old) and new messages are handled in parallel.
 - **Buffer New:** The new message is buffered and processed once the original (old) message processing is done.
- **Counter:** The number of times each collision type has occurred.



Important The Message Collision Statistics section of the command output only appears if any of the collision statistics have a counter total that is greater than zero.

Sample output:

```
Message Collision Statistics
  Interface      Old Proc (Msg Type)      New Proc (Msg Type)      Action
Counter
  SGW(S5)      NW Init Bearer Create (95)  NW Init PDN Delete (99)  Abort Old      1
```

In this instance, the output states that at the S-GW egress interface (S5) a Bearer creation procedure is going on due to a CREATE BEARER REQUEST(95) message from the P-GW. Before its response comes to the S-GW from the MME, a new procedure PDN Delete is triggered due to a DELETE BEARER REQUEST(99) message from the P-GW.

The action that is carried out due to this collision at eGTP-C is to abort (Abort Old) the Bearer Creation procedure and carry on normally with the PDN Delete procedure. The Counter total of 1 indicates that this collision happened only once.

Congestion Control

The congestion control feature allows you to set policies and thresholds and specify how the system reacts when faced with a heavy load condition.

Congestion control monitors the system for conditions that could potentially degrade performance when the system is under heavy load. Typically, these conditions are temporary (for example, high CPU or memory utilization) and are quickly resolved. However, continuous or large numbers of these conditions within a specific time interval may have an impact the system's ability to service subscriber sessions. Congestion control helps identify such conditions and invokes policies for addressing the situation.

Congestion control operation is based on configuring the following:

- **Congestion Condition Thresholds:** Thresholds dictate the conditions for which congestion control is enabled and establish limits for defining the state of the system (congested or clear). These thresholds function in a way similar to operational thresholds that are configured for the system as described in the *Thresholding Configuration Guide*. The primary difference is that when congestion thresholds are reached, a service congestion policy and an SNMP trap, starCongestion, are generated.

A threshold tolerance dictates the percentage under the configured threshold that must be reached in order for the condition to be cleared. An SNMP trap, starCongestionClear, is then triggered.

- **Port Utilization Thresholds:** If you set a port utilization threshold, when the average utilization of all ports in the system reaches the specified threshold, congestion control is enabled.
- **Port-specific Thresholds:** If you set port-specific thresholds, when any individual port-specific threshold is reached, congestion control is enabled system-wide.
- **Service Congestion Policies:** Congestion policies are configurable for each service. These policies dictate how services respond when the system detects that a congestion condition threshold has been crossed.



Important

For more information on congestion control, refer to the *Congestion Control* chapter in the *System Administration Guide*.

Dedicated Bearer Timeout Support on the S-GW

The SAE-GW has been enhanced to support a bearer inactivity timeout for GBR and non-GBR S-GW bearer type sessions per QoS Class Identifier (QCI). This enables the deletion of bearers experiencing less data traffic than the configured threshold value. Operators now can configure a bearer inactivity timeout for GBR and non-GBR bearers for more efficient use of system resources.

Downlink Delay Notification

This feature is divided between the following:

- Value Handling
- Throttling
- EPS Bearer ID and ARP Support

Value Handling

This feature provides for the handling of delay value information elements (IEs) at the S-GW. When a delay value is received at the S-GW from a particular MME, the S-GW delays sending data notification requests for all idle calls belonging to that particular MME. Once the timer expires, requests can be sent. The delay value at the S-GW is determined by the factor received in the delay value IE (as a part of either a Modify Bearer Request or a Data Downlink Notification Request) and a hard-coded base factor of 50 ms at the S-GW.

Throttling

This feature provides additional controls allowing the S-GW to set factors that "throttle" the continuous sending and receiving of DDN messages. A single command configures the throttling parameters supporting this feature,

A description of the **ddn throttle** command is located in the S-GW Service Configuration Mode Commands chapter in the *Command Line Interface Reference*.

EPS Bearer ID and ARP Support

This feature allows support for Priority Paging support in the network. This is mainly needed for MPS subscriber support. The paging priority in the paging message is set by MME based on ARP received in Downlink Data Notification message.

In order to support MPS requirement for Priority Paging in the network for MPS subscriber, DDN message has been enhanced to support passing ARP and EBI information. When the S-GW sends a Downlink Data Notification message, it shall include both EPS Bearer ID and ARP. If the Downlink Data Notification is triggered by the arrival of downlink data packets at the S-GW, the S-GW shall include the EPS Bearer ID and ARP associated with the bearer on which the downlink data packet was received. If the Downlink Data Notification is triggered by the arrival of control signaling, the S-GW shall include the EPS Bearer ID and ARP, if present in the control signaling. If the ARP is not present in the control signaling, the S-GW shall include the ARP in the stored EPS bearer context. If multiple EPS Bearers IDs are reported in the Downlink Data Notification message, the S-GW shall include all the EBI values and the ARP associated with the bearer with the highest priority (lowest ARP value). For more information, see TS 23.401 (section 5.3.4.3) and 29.274 (section 7.2.11). Details are discussed in CR-859 of 3GPP specifications.

DSCP Ingress and Egress and DSCP Marking at the APN Profile

This feature provides operators with a configuration to set the DSCP value per APN profile, so different APNs can have different DSCP markings as per QOS requirements for traffic carried by the APN. In addition, the **qci-qos mapping** table is updated with the addition of a **copy-outer** for copying the DSCP value coming in the encapsulation header from the S1u interface to the S5 interface and vice-versa.

Dynamic GTP Echo Timer

The Dynamic GTP Echo Timer enables the eGTP and GTP-U services to better manage GTP paths during network congestion. As opposed to the default echo timer which uses fixed intervals and retransmission timers, the dynamic echo timer adds a calculated round trip timer (RTT) that is generated once a full request/response procedure has completed. A multiplier can be added to the calculation for additional support during congestion periods.

Event Reporting

The S-GW can be configured to send a stream of user event data to an external server. As users attach, detach, and move throughout the network, they trigger signaling events, which are recorded and sent to an external server for processing. Reported data includes failure reasons, nodes selected, user information (IMSI, IMEI, MSISDN), APN, failure codes (if any) and other information on a per PDN-connection level. Event data is used to track the user status via near real time monitoring tools and for historical analysis of major network events.

The *S-GW Event Reporting* chapter in this guide describes the trigger mechanisms and event record elements used for event reporting.

The SGW sends each event record in comma separated values (CSV) format. The record for each event is sent to the external server within 60 seconds of its occurrence. The **session-event-module** command in the Context Configuration mode allows an operator to set the method and destination for transferring event files, as well as the format and handling characteristics of event files. For a detailed description of this command, refer to the *Command Line Interface Reference*.

GTP-C Path Failure Enhancements and Improved Debugging Tools

In StarOS release 20.0, enhancements have been added to optimize GTP-C path failure functionality, and to improve the debug capability of the system for GTP-C path failure problems. These features will help Operators and Engineers to debug different aspects of the system that will help in identifying the root cause of GTP-C path failures in the network. These enhancements affect path failure detection via the s5, s8, s2b, and s2a interfaces.

The following enhancements are added as part of this feature:

- The node can be configured so that it does not detect a path failure if a low restart counter is received due to incorrect or spurious messages. This prevents call loss. The option to disable path failure due to Echo Request/Response and Control Message Request/Response messages is also available so that call loss is prevented in the event of a false path failure detection.
- More granularity has been added to GTP-C path failure statistics so that the root cause of issues in the network can be diagnosed more quickly.
- A path failure history for the last five path failures per peer is available to assist in debugging path failures in the network.
- Seamless path failure handling is implemented so that call loss is avoided during redundancy events.

Support to Avoid False Path Failure Detection

Several enhancements have been made to facilitate the node's ability to avoid false path failure detection:

- The software has been enhanced to avoid path failure detection due to spurious/incorrect messages from a peer. These messages can cause a large burst in network traffic due to the number of service deactivations and activations, resulting in network congestion. The **gtpc** command in *eGTP-C Service Configuration Mode* has been enhanced to resolve this issue. The **max-remote-restart-counter-change** keyword has been added to ensure false path failure detections are not detected as GTP-C path failures. For example, if the **max-remote-restart-counter-change** is set to 10 and the current peer restart counter is 251, eGTP will detect a peer restart only if the new restart counter is 252 through 255 or 0 through 5. Similarly, if the stored restart counter is 1, eGTP will detect a peer restart only if the new restart counter is 2 through 11.
- Also as part of this enhancement, new keywords have been added to the **path-failure detection-policy** command in *eGTP-C Service Configuration Mode* to enable or disable path failure detection.
- The **show egtp-service all** command in Exec Mode has been enhanced to indicate whether Echo Request/Echo Response Restart Counter Change and Control Message Restart Counter Change are enabled/disabled on the node.

Improved GTP-C Path Failure Statistics

Several improvements have been made to improve the quality of the GTP-C path failures so that operators/engineers can more quickly identify the cause of the failure.

- The output of the **show egtpc statistics path-failure-reasons** has been enhanced to show the number and type of control message restart counter changes at the demuxmgr and sessmgr. This command output has also been enhanced to track the number of path failures detected that were ignored at the eGTP-C layer.
- The **show egtpc peers path-failure-history** command output has been added to provide detailed information on the last five path failures per peer.
- The output of the **show egtpc-service all name** and **show configuration** commands has been enhanced to show the current configuration settings specific to path GTP-C path failure detection policy.

Idle-mode Signaling Reduction Support

The S-GW supports Idle-mode Signaling Reduction (ISR) allowing for a control connection to exist between an S-GW and an MME and S4-SGSN. The S-GW stores mobility management parameters from both nodes while the UE stores session management contexts for both the EUTRAN and GERAN/UTRAN. This allows a UE, in idle mode, to move between the two network types without needing to perform racking area update procedures, thus reducing the signaling previously required. ISR support on the S-GW is embedded and no configuration is required however, an optional feature license is required to enable this feature.

ISR support on the S-GW is embedded and no configuration is required, however, an optional feature license must be purchased to enable this feature.

IMSI/IMEI Available in System Event Logs of Type Error and Critical

The GGSN/P-GW/SAEGW/S-GW can be configured to provide the IMSI/IMEI in the event log details for the following system event logs of type error and critical, if available.



Important Note that the GGSN/P-GW/SAEGW/S-GW will make a best effort attempt to include the IMSI/IMEI in system event logs of type error and critical. However, there still may be cases where the IMSI is not seen which are not mentioned in the following table.

Table 1: New and Modified System Event Logs with IMSI/IMEI in System Event Log Details

Event Log #	Description
New Events	
12225	Represents misc_error3 in format "[IMSI <IMSI>] Misc Error3: %s, error code %d"
12226	Represents recover_call_from_crr_failed1 error in format "[IMSI <IMSI>]Sessmgr-%d Recover call from CRR failed for callid:0x%x reason=%s"
12227	Represents aaa_create_session_failed_no_more_sessions1 error in format "[IMSI <IMSI>] Sessmgr-%d Ran out of session handles"

Event Log #	Description
140075	Represents error_log1 in format "[IMSI <IMSI>]%"
Modified Events	
139001	To print miscellaneous PGW error log.
191006	To print miscellaneous SAEGW error log.
10034	Represents FSM error in format "[IMSI <IMSI>] default call fsm error: ostate=%s(%d) state=%s(%d) event=%s(%d)"
10035	Represents FSM INVALID event in format "[IMSI <IMSI>] default call fsm invalid event: state=%s(%d) event=%s(%d)"
12382	Represents SN_LE_SESSMGR_PGW_REJECT_BEARER_OP in format "[IMSI <IMSI>] Sessmgr-%d: Request to %s bearer rejected. Reason: %s". For example "[IMSI 112233445566778 Sessmgr-1: Request to Create bearer rejected. Reason: Create Bearer Request denied as session recovery is in progress"
12668	Represents fsm_event_error in format "[IMSI <IMSI>] Misc Error: Bad event in sessmgr fsm, event code %d"
12774	Represents pgw_purge_invalid_err in format "[IMSI <IMSI>] Local %s TEID [%lu] Collision: Clp Connect Time: %lu, Old Clp Callid: %d, Old Clp Connect Time: %lu %s"
12855	Represents ncqos_nrspca_trig_err in format "[IMSI <IMSI>] NCQOS NRSPCA trig rcvd in invalid bcm mode."
12857	Represents ncqos_nrupc_tft_err in format "[IMSI <IMSI>] NCQOS NRUPC Trig : TFT validation failed for nsapi <%u>."
12858	Represents ncqos_nrxr_trig_already in format "[IMSI <IMSI>] NCQOS NRSPCA/NRUPC is already triggered on sess with nsapi <%u>."
12859	Represents ncqos_nrxr_tft_check_fail in format "[IMSI <IMSI>] NCQOS TFT check failed as TFT has invalid opcode for nsapi <%u>:pf_id_bitmap 0x%x and tft_opcode: %d"
12860	Represents ncqos_sec_rej in format "[IMSI <IMSI>] NCQOS Secondary ctxt with nsapi <%u> rejected, due to <%s>."
12861	Represents ncqos_upc_rej in format "[IMSI <IMSI>] UPC Rejected for ctxt with nsapi <%u>, due to <%s>."
12862	Represents ggsn_subsession_invalid_state in format "[IMSI <IMSI>] GGSN subsession invalid state state:<%s>,[event:<%s>]"
11830	Represents gngp_handoff_rejected_for_pdn_ipv4v6 in format "[IMSI <IMSI>] Sessmgr-%d Handoff from PGW-to-GGSN rejected, as GGSN doesn't support Deferred allocation for IPv4v6, dropping the call."

Event Log #	Description
11832	Represents gngp_handoff_rejected_no_non_gbr_bearer_for_def_bearer_selection in format "[IMSI <IMSI>] Sessmgr-%d Handoff from PGW-to-GGSN rejected, as GGSN Callline has no non-GBR bearer to be selected as Default bearer."
11834	Represents gngp_handoff_from_ggsn_rejected_no_ggsn_call in format "[IMSI <IMSI>] Sessmgr-%d Handoff from GGSN-to-PGW rejected, as GGSN call with TEIDC <0x%x> not found."
12960	Represents gtp_pdp_type_mismatch in format "[IMSI <IMSI>] Mismatch between PDP type of APN %s and in create req. Rejecting call"
11282	Represents pcc_intf_error_info in format "[IMSI <IMSI>] %s"
11293	Represents collision_error in format "[IMSI <IMSI>] Collision Error: Temp Failure Handling Delayed Pending Active Transaction: , error code %d"
11917	Represents rcvd_invalid_bearer_binding_req_from_acs in format "[IMSI <IMSI>] Sessmgr %d: Received invalid bearer binding request from ACS."
11978	Represents saegw_uid_error in format "[IMSI <IMSI>] %s"
11994	Represents unwanted_pcc_intf_setup_req error in format "[IMSI <IMSI>] GGSN_INITIATE_SESS_SETUP_REQ is already fwded to PCC interface "
140005	Represents ue_fsm_illegal_event in format "[IMSI <IMSI>] Invalid/unhandled UE event <%s> in state <%s>"
140006	Represents pdn_fsm_illegal_event in format "[IMSI <IMSI>] Invalid/unhandled PDN event <%s> in state <%s>"
140007	Represents epsb_fsm_illegal_event in format "[IMSI <IMSI>] Invalid/unhandled EPSB event <%s> in state <%s>"
10726	Represents saegwdrv_generic_error "[IMSI <IMSI>] %s"

The **include-ueid** keyword has been added to the **logging** command in *Global Configuration Mode*. When enabled, the previously mentioned system events of type error and critical will provide the IMSI/IMEI in the logging details, if available.

IP Access Control Lists

IP access control lists allow you to set up rules that control the flow of packets into and out of the system based on a variety of IP packet parameters.

IP access lists, or Access Control Lists (ACLs) as they are commonly referred to, control the flow of packets into and out of the system. They are configured on a per-context basis and consist of "rules" (ACL rules) or filters that control the action taken on packets that match the filter criteria. Once configured, an ACL can be applied to any of the following:

- An individual interface
- All traffic facilitated by a context (known as a policy ACL)

- An individual subscriber
- All subscriber sessions facilitated by a specific context



Important The S-GW supports interface-based ACLs only. For more information on IP access control lists, refer to the *IP Access Control Lists* chapter in the *System Administration Guide*.

IPv6 Capabilities

IPv6 enables increased address efficiency and relieves pressures caused by rapidly approaching IPv4 address exhaustion problem.

The S-GW platform offers the following IPv6 capabilities:

IPv6 Connections to Attached Elements

IPv6 transport and interfaces are supported on all of the following connections:

- Diameter Gxc policy signaling interface
- Diameter Rf offline charging interface
- Lawful Intercept (X1, X2 interfaces)

Routing and Miscellaneous Features

- OSPFv3
- MP-BGP v6 extensions
- IPv6 flows (Supported on all Diameter QoS and Charging interfaces as well as Inline Services (for example, ECS, P2P detection, Stateful Firewall, etc.)

LIPA Support

A LIPA (Local IP Access) PDN is a PDN Connection for local IP access for a UE connected to a HeNB. The LIPA architecture includes a Local Gateway (LGW) acting as an S-GW GTPv2 peer. The LGW is collocated with HeNB in the operator network behaves as a PGW from SGW perspective. Once the default bearer for the LIPA PDN is established, then data flows directly to the LGW and from there into the local network without traversing the core network of the network operator.

In order to support millions of LIPA GTPC peers, S-GW memory management has been enhanced with regards to GTPv2 procedures and as well as to support the maintenance of statistics per peer node.

Establishment of LIPA PDN follows a normal call flow similar to that of a normal PDN as per 23.401; the specification does not distinguish between a LGW and a PGW call. As a result, the S-GW supports a new configuration option to detect a LIPA peer. As a fallback mechanism, heuristic detection of LIPA peer based on data flow characteristics of a LIPA call is also supported.

Whenever a peer is detected as a LIPA peer, the S-GW will disable GTPC echo mechanism towards that particular peer and stop maintaining some statistics for that peer.

A configuration option in APN profile explicitly indicates that all the PDN's for that APN are LIPA PDN's, so all GTPC peers on S5 for that APN are treated as LGW, and thus no any detection algorithm is applied to detect LGW.

Location Reporting

Location reporting can be used to support a variety of applications including emergency calls, lawful intercept, and charging. This feature reports both user location information (ULI).

ULI data reported in GTPv2 messages includes:

- **TAI-ID:** Tracking Area Identity
- **MCC: MNC:** Mobile Country Code, Mobile Network Code
- **TAC:** Tracking Area Code

The S-GW stores the ULI and also reports the information to the accounting framework. This may lead to generation of Gz and Rf Interim records. The S-GW also forwards the received ULI to the P-GW. If the S-GW receives the UE time zone IE from the MME, it forwards this IE towards the P-GW across the S5/S8 interface.

Mapping High Throughput Sessions on Session Managers

Session managers are upgraded to manage several high throughput sessions without sharing the core and without creating a bottleneck on the CPU load.

The gateway – S-GW, SAEGW or P-GW, classifies a session as a high throughput session based on a DCNR flag present in the IE: FLAGS FOR USER PLANE FUNCTION (UPF) SELECTION INDICATION, in the Create Session Request. This DCNR flag is checkpointed and recovered by the gateway.

A high throughput session is placed on a session manager that has no other high throughput session. If all session manager are handling a high throughput session then these sessions are allocated using the Round-Robbin method.



Note

- The selection of session managers for non-high throughput sessions remains the same in the existing setup.
- Non-high throughput sessions are placed along with the high throughput sessions on the same session manager.

Limitations

Managing high throughput sessions on a session manager has the following limitations:

- The following scenarios may result in placing two high throughput sessions on a session manager:
 - Initial attach from eHRPD/2G/3G sessions.
 - IP addresses – both IPv4 and IPv6, are placed on the same session manager.
 - For an S-GW, the second Create Session Request (PDN) from a UE lands directly on a session manager which has the first PDN of the same UE.

- For a collapsed call, the second Create Session Request (PDN) from a UE lands directly on a session manager which has the first PDN of the same UE.
- In a Multi-PDN call from a UE that is capable of DCNR. For example: VoLTE and Internet capable of DCN will be placed on the same session manager.
- The DCNR flag is not defined by 3GPP for Wi-Fi. Therefore, a session cannot be assigned to a session manager during a Wi-Fi to LTE handover with the DCNR flag set.
- This feature manages and supports distribution of high throughput sessions on a session manager but does not guarantee high throughput for a subscriber.
- In some cases, the round robin mechanism could place a high throughput session on a session manager that was already loaded with other high throughput sessions.

MME Restoration Support

MME restoration is a 3GPP specification-based feature designed to gracefully handle the sessions at S-GW once S-GW detects that the MME has failed or restarted. If the S-GW detects an MME failure based on a different restart counter in the Recovery IE in any GTP Signaling message or Echo Request / Response, it will terminate sessions and not maintain any PDN connections.

MME Restoration Standards Extension

The solution to recover from MME node failures proposed in the 3GPP standards rely on the deployment of MME pools where each pool services a coverage area. Following an MME failure, the S-GW and MSC/VLR nodes may select the same MME that used to service a UE, if it has restarted, or an alternate MME in the same pool to process Network-initiated signaling that it received in accordance with the NTSR procedures defined in 3GPP TS 23.007 Release 11.

For a failed MME, the S-GW will select an alternate MME from the associated NTSR pool in the round robin fashion in each sessmgr instance.

S-GW NTSR Enhancement

CDETS=CSCuv99767 - [SGW] NTSR Enhancement

Applicable Products: S-GW

Multiple PDN Support

Enables an APN-based user experience that enables separate connections to be allocated for different services including IMS, Internet, walled garden services, or offdeck content services.

The Mobile Access Gateway (MAG) function on the S-GW can maintain multiple PDN or APN connections for the same user session. The MAG runs a single node level Proxy Mobile IPv6 (PMIP) tunnel for all user sessions toward the Local Mobility Anchor (LMA) function of the P-GW.

When a user wants to establish multiple PDN connections, the MAG brings up the multiple PDN connections over the same PMIPv6 session to one or more P-GW LMAs. The P-GW in turn allocates separate IP addresses (Home Network Prefixes) for each PDN connection and each one can run one or multiple EPC default and dedicated bearers. To request the various PDN connections, the MAG includes a common MN-ID and separate Home Network Prefixes, APNs and a Handover Indication Value equal to one in the PMIPv6 Binding Updates.



Important Up to 11 multiple PDN connections are supported.

Node Functionality GTP Echo

This feature helps exchange capabilities of two communicating GTP nodes, and uses the feature based on whether it is supported by the other node.

This feature allows S-GW to exchange its capabilities (MABR, PRN, NTSR) with the peer entities through ECHO messages. By this, if both the peer nodes support some common features, then they can make use of new messages to communicate with each other.

With new "node features" IE support in ECHO request/response message, each node can send its supported features (MABR, PRN, NTSR). This way, S-GW can learn the peer node's supported features. S-GW's supported features can be configured by having some configuration at the service level.

If S-GW wants to use new message, such as P-GW Restart Notification, then S-GW should check if the peer node supports this new feature or not. If the peer does not support it, then S-GW should fall back to old behavior.

If S-GW receives a new message from the peer node, and if S-GW does not support this new message, then S-GW should ignore it. If S-GW supports the particular feature, then it should handle the new message as per the specification.

Online/Offline Charging

The Cisco EPC platforms support offline charging interactions with external OCS and CGF/CDF servers. To provide subscriber level accounting, the Cisco EPC platform supports integrated Charging Transfer Function (CTF) and Charging Data Function (CDF) / Charging Gateway Function (CGF). Each gateway uses Charging-IDs to distinguish between default and dedicated bearers within subscriber sessions.

The ASR 5500 platform offers a local directory to enable temporary file storage and buffer charging records in persistent memory located on a pair of dual redundant RAID hard disks. Each drive includes 147GB of storage and up to 100GB of capacity is dedicated to storing charging records. For increased efficiency it also possible to enable file compression using protocols such as GZIP.

The offline charging implementation offers built-in heart beat monitoring of adjacent CGFs. If the Cisco P-GW has not heard from the neighboring CGF within the configurable polling interval, it will automatically buffer the charging records on the local drives until the CGF reactivates itself and is able to begin pulling the cached charging records.



Note Online Charging is not supported on the S-GW.

Online: Gy Reference Interface

The P-GW supports a Policy Charging Enforcement Function (PCEF) to enable Flow Based Bearer Charging (FBC) via the Gy reference interface to adjunct Online Charging System (OCS) servers. The Gy interface provides a standardized Diameter interface for real-time content-based charging of data services. It is based on the 3GPP standards and relies on quota allocation. The Gy interface provides an online charging interface

that works with the ECS Deep Packet Inspection feature. With Gy, customer traffic can be gated and billed. Both time- and volume-based charging models are supported.

Offline: Gz Reference Interface

The Cisco P-GW and S-GW support 3GPP Release 8 compliant offline charging as defined in TS 32.251, TS 32.297 and 32.298. Whereas the S-GW generates SGW-CDRs to record subscriber level access to PLMN resources, the P-GW creates PGW-CDRs to record user access to external networks. Additionally when Gn/Gp interworking with SGSNs is enabled, the GGSN service on the P-GW records G-CDRs to record user access to external networks.

To provide subscriber level accounting, the Cisco S-GW supports integrated Charging Transfer Function (CTF) and Charging Data Function (CDF). Each gateway uses Charging-IDs to distinguish between default and dedicated bearers within subscriber sessions.

The Gz reference interface between the CDF and CGF is used to transfer charging records via the GTPP protocol. In a standards based implementation, the CGF consolidates the charging records and transfers them via an FTP or SFTP connection over the Bm reference interface to a back-end billing mediation server. The Cisco EPC gateways also offer the ability to transfer charging records between the CDF and CGF serve via FTP or SFTP. CDR records include information such as Record Type, Served IMSI, ChargingID, APN Name, TimeStamp, Call Duration, Served MSISDN, PLMN-ID, etc.

Offline: Rf Reference Interface



Important Offline Charging via the RF Reference Interface is not supported in StarOS releases 19 and later.

Cisco EPC platforms also support the Rf reference interface to enable direct transfer of charging files from the CTF function of the S-GW to external CDF or CGF servers. This interface uses Diameter Accounting Requests (Start, Stop, Interim, and Event) to transfer charging records to the CDF/CGF. Each gateway relies on triggering conditions for reporting chargeable events to the CDF/CGF. Typically as EPS bearers are activated, modified or deleted, charging records are generated. The EPC platforms include information such as Subscription-ID (IMSI), Charging-ID (EPS bearer identifier) and separate volume counts for the uplink and downlink traffic.

Operator Policy Support

The operator policy provides mechanisms to fine tune the behavior of subsets of subscribers above and beyond the behaviors described in the user profile. It also can be used to control the behavior of visiting subscribers in roaming scenarios, enforcing roaming agreements and providing a measure of local protection against foreign subscribers.

An operator policy associates APNs, APN profiles, an APN remap table, and a call-control profile to ranges of IMSIs. These profiles and tables are created and defined within their own configuration modes to generate sets of rules and instructions that can be reused and assigned to multiple policies. In this manner, an operator policy manages the application of rules governing the services, facilities, and privileges available to subscribers. These policies can override standard behaviors and provide mechanisms for an operator to get around the limitations of other infrastructure elements, such as DNS servers and HSSs.

The operator policy configuration to be applied to a subscriber is selected on the basis of the selection criteria in the subscriber mapping at attach time. A maximum of 1,024 operator policies can be configured. If a UE

was associated with a specific operator policy and that policy is deleted, the next time the UE attempts to access the policy, it will attempt to find another policy with which to be associated.

A default operator policy can be configured and applied to all subscribers that do not match any of the per-PLMN or IMSI range policies.

The S-GW uses operator policy to set the Accounting Mode - GTPP (default), RADIUS/Diameter or none. However, the accounting mode configured for the call-control profile will override this setting.

Changes to the operator policy take effect when the subscriber re-attaches and subsequent EPS Bearer activations.

Optimization for egtpinmgr Recovery

Restarting the egtpinmgr task took a significant amount of time for recovery. Hence, the outage time when the GGSN, P-GW, SAEGW, and S-GW were unable to accept any new calls during egtpinmgr recovery was high.

The software is enhanced to optimize the recovery outage window in the event of an egtpinmgr task restart; this has been achieved by optimizing the internal algorithms of egtpinmgr recovery and the data structures required. In addition, recovery time now is dependent only on the number of unique IMSIs and not on the number of sessions for an IMSI.

Peer GTP Node Profile Configuration Support

Provides flexibility to the operators to have different configuration for GTP-C and Lawful Intercept, based on the type of peer or the IP address of the peer.

Peer profile feature allows flexible profile based configuration to accommodate growing requirements of customizable parameters with default values and actions for peer nodes of S-GW. With this feature, configuration of GTP-C parameters and disabling/enabling of Lawful Intercept per MCC/MNC or IP address based on rules defined.

A new framework of peer-profile and peer-map is introduced. Peer-profile configuration captures the GTP-C specific configuration and/or Lawful Intercept enable/disable configuration. GTP-C configuration covers GTP-C retransmission (maximum number of retries and retransmission timeout) and GTP echo configuration. Peer-map configuration matches the peer-profile to be applied to a particular criteria. Peer-map supports criteria like MCC/MNC (PLMN-ID) of the peer or IP-address of the peer. Peer-map can then be associated with S-GW service.

Intent of this feature is to provide flexibility to operators to configure a profile which can be applied to a specific set of peers. For example, have a different retransmission timeout for foreign peers as compared to home peers.

P-GW Restart Notification Support

This procedure optimizes the amount of signaling involved on the S11/S4 interface when a P-GW failure is detected.

P-GW Restart Notification Procedure is a standards-based procedure supported on S-GW to notify detection of P-GW failure to MME/S4-SGSN. P-GW failure detection will be done at S-GW when it detects that the P-GW has restarted (based on restart counter received from the restarted P-GW) or when it detects that P-GW has failed but not restarted (based on path failure detection). When an S-GW detects that a peer P-GW has

restarted, it shall locally delete all PDN connection table data and bearer contexts associated with the failed P-GW and notify the MME via P-GW Restart Notification. S-GW will indicate in the echo request/response on S11/S4 interface that the P-GW Restart Notification procedure is supported.

P-GW Restart Notification Procedure is an optional procedure and is invoked only if both the peers, MME/S4-SGSN and S-GW, support it. This procedure optimizes the amount of signaling involved on S11/S4 interface when P-GW failure is detected. In the absence of this procedure, S-GW will initiate the Delete procedure to clean up all the PDNs anchored at that failed P-GW, which can lead to flooding of GTP messages on S11/S4 if there are multiple PDNs using that S-GW and P-GW.

QoS Bearer Management

Provides a foundation for contributing towards improved Quality of User Experience (QoE) by enabling deterministic end-to-end forwarding and scheduling treatments for different services or classes of applications pursuant to their requirements for committed bandwidth resources, jitter and delay. In this way, each application receives the service treatment that users expect.

An EPS bearer is a logical aggregate of one or more Service Data Flows (SDFs), running between a UE and a P-GW in case of GTP-based S5/S8, and between a UE and HSGW in case of PMIP-based S2a connection. An EPS bearer is the level of granularity for bearer level QoS control in the EPC/E-UTRAN. The Cisco P-GW maintains one or more Traffic Flow Templates (TFTs) in the downlink direction for mapping inbound Service Data Flows (SDFs) to EPS bearers. The P-GW maps the traffic based on the downlink TFT to the S5/S8 bearer. The Cisco P-GW offers all of the following bearer-level aggregate constructs:

QoS Class Identifier (QCI): An operator provisioned value that controls bearer level packet forwarding treatments (for example, scheduling weights, admission thresholds, queue management thresholds, link layer protocol configuration, etc). Cisco EPC gateways also support the ability to map the QCI values to DiffServ codepoints in the outer GTP tunnel header of the S5/S8 connection. Additionally, the platform also provides configurable parameters to copy the DSCP marking from the encapsulated payload to the outer GTP tunnel header.



Important The SAEGW does not support non-standard QCI values. QCI values 1 through 9 are standard values defined in 3GPP TS 23.203; the SAEGW supports these standard values.

Guaranteed Bit Rate (GBR): A GBR bearer is associated with a dedicated EPS bearer and provides a guaranteed minimum transmission rate in order to offer constant bit rate services for applications such as interactive voice that require deterministic low delay service treatment.

Maximum Bit Rate (MBR): The MBR attribute provides a configurable burst rate that limits the bit rate that can be expected to be provided by a GBR bearer (e.g. excess traffic may get discarded by a rate shaping function). The MBR may be greater than or equal to the GBR for a given dedicated EPS bearer.

Aggregate Maximum Bit Rate (AMBR): AMBR denotes a bit rate of traffic for a group of bearers destined for a particular PDN. The Aggregate Maximum Bit Rate is typically assigned to a group of Best Effort service data flows over the Default EPS bearer. That is, each of those EPS bearers could potentially utilize the entire AMBR, e.g. when the other EPS bearers do not carry any traffic. The AMBR limits the aggregate bit rate that can be expected to be provided by the EPS bearers sharing the AMBR (e.g. excess traffic may get discarded by a rate shaping function). AMBR applies to all Non-GBR bearers belonging to the same PDN connection. GBR bearers are outside the scope of AMBR.

Policing: The Cisco P-GW offers a variety of traffic conditioning and bandwidth management capabilities. These tools enable usage controls to be applied on a per-subscriber, per-EPS bearer or per-PDN/APN basis.

It is also possible to apply bandwidth controls on a per-APN AMBR capacity. These applications provide the ability to inspect and maintain state for user sessions or Service Data Flows (SDFs) within them using shallow L3/L4 analysis or high touch deep packet inspection at L7. Metering of out-of-profile flows or sessions can result in packet discards or reducing the DSCP marking to Best Effort priority.

Removal of Private Extension-based Overcharging Feature

Prior to StarOS release 21.0, the Cisco P-GW and S-GW supported the sending and receiving of overcharging protection data via both a non-3GPP Private Extension Information Element (IE), and a 3GPP Indication IE.

However, since 3GPP support to exchange overcharging protection data exists, no operators were using the Overcharging Private Extension (OCP) based solution. It was also reported by some operators that the Private Extension IE carrying overcharging protection data sent by the P-GW was leading to issues at S-GWs of other vendors.

As a result, support for Private Extension-based Overcharging Support is being removed from the Cisco P-GW and S-GW. This has the benefit of preventing unexpected scenarios occurring due to the decoding of a Private Extension ID carrying overcharging protection data at the P-GW/S-GW of other vendors.

Previous and New Behavior for the P-GW

The following table describes the previous and new behavior at the P-GW for Create Session Request (CSReq) and Create Session Response (CSRsp) messages due to the removal of Private Extension Overcharging Support.

Table 2: Previous and New Behavior: CSReq and CSRsp Messages at P-GW Due to Removal of Private Extension Overcharging Support

Scenario No.	IE Carrying OCP Capability Received from S-GW in CSReq	Old Behavior: IE carrying OCP Capability Sent to S-GW in CSRsp	New Behavior: IE Carrying OCP Capability Sent to S-GW in CSRsp
1	Indication IE	Indication IE	No change. Indication IE will be sent in CSRsp.
2	Private Extension IE	Both Private Extension and Indication IEs.	Private Extension IE received from S-GW is ignored. Indication IE is sent in CSRsp.
3	None	Both Private Extension and Indication IEs.	Only Indication IE is sent in CSRsp.
4	Both Private Extension and Indication IEs.	Indication IE	Private Extension IE received from S-GW is ignored. Only Indication IE is sent in CSRsp.

The following table describes the previous and new behavior in Modify Bearer Request (MBReq) and Modify Bearer Response (MBRsp) messages due to the removal of Private Extension Overcharging Support.

Table 3: Previous and New Behavior: MBRreq and MBRsp Messages at P-GW Due to Removal of Private Extension Overcharging Support

Scenario No.	IE carrying OCP Capability Received from S-GW in MBRreq	Old Behavior: IE Carrying OCP Capability Sent to S-GW in MBRsp	New Behavior: IE Carrying OCP Capability Sent to S-GW in MBRsp
1	Indication IE	Indication IE	No Change. Indication IE is sent in MBRsp messages.
2	Private Extension IE	Private Extension IE	Private Extension IE received from S-GW is ignored. Indication IE is sent in MBRsp message.
3	None	Both Private Extension and Indication IEs.	Only the Indication IE is sent in MBRsp message.
4	Both Private Extension and Indication IEs.	Indication IE	Private Extension IE received from the S-GW is ignored. Only the Indication IE is sent in the MBRsp message.

Previous and New Behavior for the S-GW

The following table describes the previous and new behavior in Create Session Response (CSRsp) messages at the S-GW due to the removal of Private Extension Overcharging Support.

Table 4: Previous and New Behavior: CSRsp Messages at the S-GW Due to the Removal of Private Extension Overcharging Support

Scenario No.	Old Behavior: IE Carrying OCP Capability Received from P-GW in CSRsp	New Behavior: IE Carrying OCP Capability Received from PGW in CSRsp	Old Behavior: IE Carrying OCP Capability Sent to MME in CSRsp	New Behavior: IE Carrying OCP Capability Sent to MME in CSRsp
12	Indication IE	No change. OCP capability received as part of the Indication IE is accepted.	Indication IE	No change. Indication IE is sent in CSRsp.
2	Private Extension IE	OCP capability received as part of Private Extension IE is ignored.	If gtpc private-extension overcharge-protection is disabled at egtpc service level: Private Extension IE . If gtpc private-extension overcharge-protection is enabled at egtpc service level: Indication IE .	Since the CLI command is deprecated, then the Private Extension IE is forwarded to the MME in CSRsp as would be done for any unknown Private Extension IE.

Scenario No.	Old Behavior: IE Carrying OCP Capability Received from P-GW in CSRsp	New Behavior: IE Carrying OCP Capability Received from PGW in CSRsp	Old Behavior: IE Carrying OCP Capability Sent to MME in CSRsp	New Behavior: IE Carrying OCP Capability Sent to MME in CSRsp
3	Both Private Extension IE and Indication IE	OCP capability received as part of the Private Extension IE is ignored. Only OCP capability received as a part of the Indication IE is accepted.	If gtpc private-extension overcharge-protection is disabled at egtpc service level: Private Extension IE and Indication IE . If gtpc private-extension overcharge-protection is enabled at egtpc service level: Indication IE .	Since the CLI command is deprecated, then the Private Extension IE is forwarded to the MME in CSRsp as would be done for any unknown Private Extension IE.
4	None	No change.	None	No change.

The following table describes the previous and new behavior in Modify Bearer Response (MBRsp) messages at the S-GW due to the removal of Private Extension Overcharging Support.

Table 5: Previous Behavior and New Behavior: MBRsp Messages at the S-GW Due to the Removal of Private Extension Overcharging Support

Scenario No.	Old Behavior: IE Carrying OCP Capability Received from P-GW in MBRsp	New Behavior: IE Carrying OCP Capability Received from P-GW in MBRsp	Old Behavior: IE Carrying OCP Capability Sent to MME in MBRsp	New Behavior: IE Carrying OCP Capability Sent to MME in MBRsp
1	Indication IE	No change. OCP capability received as part of Indication IE is accepted.	Indication IE	No change. Indication IE is sent in MBRsp.
2	Private Extension IE	OCP capability received as part of Private Extension IE is ignored.	If gtpc private-extension overcharge-protection is disabled at egtpc service level: None . If gtpc private-extension overcharge-protection is enabled at egtpc service level: Indication IE .	Since the CLI command is deprecated, neither one of the two IEs is sent in the MBRsp to the MME for the OCP capability.
3	Both Private Extension ID and Indication IE	OCP capability received as part of the Private Extension IE is ignored. Only the OCP capability received as part of the Indication IE is accepted.	Indication IE	No change. Indication IE is sent in MBRsp.

Scenario No.	Old Behavior: IE Carrying OCP Capability Received from P-GW in MBRsp	New Behavior: IE Carrying OCP Capability Received from P-GW in MBRsp	Old Behavior: IE Carrying OCP Capability Sent to MME in MBRsp	New Behavior: IE Carrying OCP Capability Sent to MME in MBRsp
4	None	None	None	No change.



Important In the current release, the S-GW will send a MBReq message with only the indication IE for the Pause/Start Charging procedure. The private extension IE is not sent.



Important If the S-GW receives only the private extension IE from the P-GW in the CSRsp/MBRsp message, then the S-GW ignores the private extension IE. As a result, the S-GW assumes that Overcharging Protection is NOT enabled for the P-GW. So, in this scenario, even if the overcharging condition is met at the S-GW, the S-GW will not send a MBReq message for Charging pause to the P-GW.

Rf Diameter Accounting



Important In StarOS 19 and later versions, Rf Diameter Accounting is not supported on the S-GW.

Provides the framework for offline charging in a packet switched domain. The gateway support nodes use the Rf interface to convey session related, bearer related or service specific charging records to the CGF and billing domain for enabling charging plans.

The Rf reference interface enables offline accounting functions on the HSGW in accordance with 3GPP Release 8 specifications. In an LTE application the same reference interface is also supported on the S-GW and P-GW platforms. The Cisco gateways use the Charging Trigger Function (CTF) to transfer offline accounting records via a Diameter interface to an adjunct Charging Data Function (CDF) / Charging Gateway Function (CGF). The HSGW and Serving Gateway collect charging information for each mobile subscriber UE pertaining to the radio network usage while the P-GW collects charging information for each mobile subscriber related to the external data network usage.

The S-GW collects information per-user, per IP CAN bearer or per service. Bearer charging is used to collect charging information related to data volumes sent to and received from the UE and categorized by QoS traffic class. Users can be identified by MSISDN or IMSI.

Flow Data Records (FDRs) are used to correlate application charging data with EPC bearer usage information. The FDRs contain application level charging information like service identifiers, rating groups, IMS charging identifiers that can be used to identify the application. The FDRs also contain the authorized QoS information (QCI) that was assigned to a given flow. This information is used correlate charging records with EPC bearers.

S-GW Collision Handling

GTPv2 message collisions occur in the network when a node is expecting a particular procedure message from a peer node but instead receives a different procedure message from the peer. The S-GW has been enhanced to process collisions at the S-GW ingress interface for:

1. Create Bearer Request or Update Bearer Request messages with Inter-MME/Inter-RAT Modify Bearer Request messages (with and without a ULI change).
2. Downlink Data Notification(DDN) message with Create Bearer Request or Update Bearer Request.

An UBReq and MBReq [(Inter MME/Inter RAT (with or without a ULI change))] collision at the SGW ingress interface is handled with a suspend and resume procedure. The UBReq would be suspended and the MBReq would be processed. Once the MBRsp is sent to the peer from the SGW ingress interface, the UBReq procedure is resumed.

An UBReq and MBReq [(Inter MME/Inter RAT (with or without a ULI change))] collision at the SGW ingress interface is handled with a suspend and resume procedure. The UBReq would be suspended and the MBReq would be processed. Once the MBRsp is sent to the peer from the SGW ingress interface, the UBReq procedure is resumed.

The Downlink Data Notification (DDN) message transaction is dis-associated from bearers. So Create Bearer Request (CBR) or Update Bearer Request (UBR) with Downlink Data Notification (DDN) messages are handled parallel.

No S-GW initiated Cause Code message 110 (Temporarily rejected due to handover procedure in progress) will be seen as a part of such collisions. Collisions will be handled in parallel.

Viewing S-GW Collision Handling Statistics

The output of the **show egtp statistics verbose** command has been enhanced to provide information on GTPv2 message collisions at the S-GW ingress interface, including:

- **Interface:** The interface on which the collision occurred: SGW (S4/S11), SGW (S5).
- **Old Proc (Msg Type):** Indicates the ongoing procedure at eGTP-C when a new message arrived at the interface which caused the collision. The Msg Type in brackets specifies which message triggered this ongoing procedure.
- **New Proc (Msg Type):** The new procedure and message type.
- **Action:** The pre-defined action taken to handle the collision. The action can be one of:
 - **No Collision Detected**
 - **Suspend Old:** Suspend processing of the original (old) message, process the new message, then resume old message handling.
 - **Abort Old:** Abort the original message handling and processes the new message.
 - **Reject New:** The new message is rejected, and the original (old) message is processed.
 - **Silent Drop New:** Drop the new incoming message, and the old message is processed.
 - **Parallel Hndl:** Both the original (old) and new messages are handled in parallel.
 - **Buffer New:** The new message is buffered and processed once the original (old) message processing is done.
- **Counter:** The number of times each collision type has occurred.



Important The *Message Collision Statistics* section of the command output appears only if any of the collision statistics have a counter total that is greater than zero.

For more information on this feature, refer to the *Collision Handling on the P-GW/SAEGW/S-GW* chapter in this document.

S-GW Session Idle Timer

A session idle timer has been implemented on the S-GW to remove stale session in those cases where the session is removed on the other nodes but due to some issue remains on the S-GW. Once configured, the session idle timer will tear down those sessions that remain idle for longer than the configured time limit. The implementation of the session idle timer allows the S-GW to more effectively utilize system capacity.



Important The session idle timer feature will not work if the Fast Data Path feature is enabled.

Subscriber Level Trace

Provides a 3GPP standards-based session level trace function for call debugging and testing new functions and access terminals in an LTE environment.

As a complement to Cisco's protocol monitoring function, the S-GW supports 3GPP standards based session level trace capabilities to monitor all call control events on the respective monitored interfaces including S1-U, S11, S5/S8, and Gxc. The trace can be initiated using multiple methods:

- Management initiation via direct CLI configuration
- Management initiation at HSS with trace activation via authentication response messages over S6a reference interface
- Signaling based activation through signaling from subscriber access terminal

Note: Once the trace is provisioned it can be provisioned through the access cloud via various signaling interfaces.

The session level trace function consists of trace activation followed by triggers. The EPC network element buffers the trace activation instructions for the provisioned subscriber in memory using camp-on monitoring. Trace files for active calls are buffered as XML files using non-volatile memory on the local dual redundant hard drives on the ASR 5500 platform. The Trace Depth defines the granularity of data to be traced. Six levels are defined including Maximum, Minimum and Medium with ability to configure additional levels based on vendor extensions.

All call control activity for active and recorded sessions is sent to an off-line Trace Collection Entity (TCE) using a standards-based XML format over an FTP or secure FTP (SFTP) connection. In the current release the IPv4 interfaces are used to provide connectivity to the TCE. Trace activation is based on IMSI or IMEI.

Once a subscriber level trace request is activated it can be propagated via the S5/S8 signaling to provision the corresponding trace for the same subscriber call on the P-GW. The trace configuration will only be propagated if the P-GW is specified in the list of configured Network Element types received by the S-GW. Trace configuration can be specified or transferred in any of the following message types:

- S11: Create Session Request
- S11: Trace Session Activation
- S11: Modify Bearer Request

As subscriber level trace is a CPU intensive activity the maximum number of concurrently monitored trace sessions per Cisco P-GW or S-GW is 32. Use in a production network should be restricted to minimize the impact on existing services.

Threshold Crossing Alerts (TCA) Support

Thresholding on the system is used to monitor the system for conditions that could potentially cause errors or outage. Typically, these conditions are temporary (i.e high CPU utilization, or packet collisions on a network) and are quickly resolved. However, continuous or large numbers of these error conditions within a specific time interval may be indicative of larger, more severe issues. The purpose of thresholding is to help identify potentially severe conditions so that immediate action can be taken to minimize and/or avoid system downtime.

The system supports Threshold Crossing Alerts for certain key resources such as CPU, memory, IP pool addresses, etc. With this capability, the operator can configure threshold on these resources whereby, should the resource depletion cross the configured threshold, a SNMP Trap would be sent.

The following thresholding models are supported by the system:

- **Alert:** A value is monitored and an alert condition occurs when the value reaches or exceeds the configured high threshold within the specified polling interval. The alert is generated then generated and/or sent at the end of the polling interval.
- **Alarm:** Both high and low threshold are defined for a value. An alarm condition occurs when the value reaches or exceeds the configured high threshold within the specified polling interval. The alert is generated then generated and/or sent at the end of the polling interval.

Thresholding reports conditions using one of the following mechanisms:

- **SNMP traps:** SNMP traps have been created that indicate the condition (high threshold crossing and clear) of each of the monitored values.

Generation of specific traps can be enabled or disabled on the chassis. Ensuring that only important faults get displayed. SNMP traps are supported in both Alert and Alarm modes.

- **Logs:** The system provides a facility called threshold for which active and event logs can be generated. As with other system facilities, logs are generated Log messages pertaining to the condition of a monitored value are generated with a severity level of WARNING.

Logs are supported in both the Alert and the Alarm models.

- **Alarm System:** High threshold alarms generated within the specified polling interval are considered outstanding until a the condition no longer exists or a condition clear alarm is generated. Outstanding alarms are reported to the system's alarm subsystem and are viewable through the Alarm Management menu in an element management system.

The Alarm System is used only in conjunction with the Alarm model.



Important For more information on threshold crossing alert configuration, refer to the *Thresholding Configuration Guide*.

ULI Enhancements

VoLTE carriers need the last cell/sector updates within the IMS CDRs to assist in troubleshooting customer complaints due to dropped calls as well as LTE network analysis, performance, fraud detection, and operational maintenance. The ultimate objective is to get the last cell sector data in the IMS CDR records in addition to the ULI reporting for session establishment.

To address this issue, the S-GW now supports the following:

- RAN/NAS Cause IE within bearer context of Delete Bearer Command message.
- The S-GW ignores the ULI received as call is going down so there is no point in updating the CDR.

This feature provides support for ULI and ULI Timestamp in Delete Bearer Command message.

Now, when a new ULI is received in the Delete Bearer Command message, a S-GW CDR is initiated.

P-GW Features and Functionality - Base Software



Important The SAEGW supports all of these features if a P-GW service is assigned to the SAEGW service.

This section describes the features and functions supported by default in the base software for the P-GW service and do not require any additional licenses to implement the functionality.



Important To configure the basic service and functionality on the system for the P-GW service, refer to the configuration examples provided in this guide.

3GPP R9 Volume Charging Over Gx

Also known as accumulated usage tracking over Gx, this 3GPP R9 enhancement provides a subset of the volume and charging control functions defined in TS 29.212 based on usage quotas between a P-GW and PCRF. The quotas can be assigned to the default bearer or any of the dedicated bearers for the PDN connection.

This feature enables volume reporting over Gx, which entails usage monitoring and reporting of the accumulated usage of network resources on an IP-CAN session or service data flow basis. PCRF subscribes to the usage monitoring at session level or at flow level by providing the necessary information to PCEF. PCEF in turn reports the usage to the PCRF when the conditions are met. Based on the total network usage in real-time, the PCRF will have the information to enforce dynamic policy decisions.

When usage monitoring is enabled, the PCEF can monitor the usage volume for the IP-CAN session, or applicable service data flows, and report accumulated usage to the PCRF based on any of the following conditions:

- When a usage threshold is reached,

- When all PCC rules for which usage monitoring is enabled for a particular usage monitoring key are removed or deactivated,
- When usage monitoring is explicitly disabled by the PCRF,
- When an IP CAN session is terminated or,
- When requested by the PCRF.

Accumulated volume reporting can be measured by total volume, the uplink volume, or the downlink volume as requested by the PCRF. When receiving the reported usage from the PCEF, the PCRF deducts the value of the usage report from the total allowed usage for that IP-CAN session, usage monitoring key, or both as applicable.

AAA Server Groups

Value-added feature to enable VPN service provisioning for enterprise or MVNO customers. Enables each corporate customer to maintain its own AAA servers with its own unique configurable parameters and custom dictionaries.

This feature provides support for up to 800 AAA server groups and 800 NAS IP addresses that can be provisioned within a single context or across the entire chassis. A total of 128 servers can be assigned to an individual server group. Up to 1,600 accounting, authentication and/or mediation servers are supported per chassis.

ANSI T1.276 Compliance

ANSI T1.276 specifies security measures for Network Elements (NE). In particular it specifies guidelines for password strength, storage, and maintenance security measures.

ANSI T1.276 specifies several measures for password security. These measures include:

- Password strength guidelines
- Password storage guidelines for network elements
- Password maintenance, e.g. periodic forced password changes

These measures are applicable to the ASR 5500 and an element management system since both require password authentication. A subset of these guidelines where applicable to each platform will be implemented. A known subset of guidelines, such as certificate authentication, are not applicable to either product. Furthermore, the platforms support a variety of authentication methods such as RADIUS and SSH which are dependent on external elements. ANSI T1.276 compliance in such cases will be the domain of the external element. ANSI T1.276 guidelines will only be implemented for locally configured operators.

APN Support

The P-GW's Access Point Name (APN) support offers several benefits:

- Extensive parameter configuration flexibility for the APN.
- Creation of subscriber tiers for individual subscribers or sets of subscribers within the APN.
- Virtual APNs to allow differentiated services within a single APN.

In StarOS v12.x and earlier, up to 1024 APNs can be configured in the P-GW. In StarOS v14.0 and later, up to 2048 APNs can be configured in the P-GW. An APN may be configured for any type of PDP context, i.e., PPP, IPv4, IPv6 or both IPv4 and IPv6. Many dozens of parameters may be configured independently for each APN.

Here are a few highlights of what may be configured:

- **Accounting:** RADIUS, GTPP or none. Server group to use. Charging characteristics. Interface with mediation servers.
- **Authentication:** Protocol, such as, CHAP or PAP or none. Default username/password. Server group to use. Limit for number of PDP contexts.
- **Enhanced Charging:** Name of rulebase to use, which holds the enhanced charging configuration (e.g., eG-CDR variations, charging rules, prepaid/postpaid options, etc.).
- **IP:** Method for IP address allocation (e.g., local allocation by P-GW, Mobile IP, DHCP, etc.). IP address ranges, with or without overlapping ranges across APNs.
- **Tunneling:** PPP may be tunneled with L2TP. IPv4 may be tunneled with GRE, IP-in-IP or L2TP. Load-balancing across multiple tunnels. IPv6 is tunneled in IPv4. Additional tunneling techniques, such as, IPsec and VLAN tagging may be selected by the APN, but are configured in the P-GW independently from the APN.
- **QoS:** IPv4 header ToS handling. Traffic rate limits for different 3GPP traffic classes. Mapping of R98 QoS attributes to work around particular handset defections. Dynamic QoS renegotiation (described elsewhere).

After an APN is determined by the P-GW, the subscriber may be authenticated/authorized with an AAA server. The P-GW allows the AAA server to return VSAs (Vendor Specific Attributes) that override any/all of the APN configuration. This allows different subscriber tier profiles to be configured in the AAA server, and passed to the P-GW during subscriber authentication/authorization.

Assume Positive for Gy-based Quota Tracking

In the current implementation, the PCEF uses a Diameter based Gy interface to interact with the OCS and obtain quota for each subscriber's data session. Now, the PCEF can retry the OCS after a configured amount of quota has been utilized or after a configured amount of time. The quota value would be part of the dcca-service configuration, and would apply to all subscribers using this dcca-service. The temporary quota will be specified in volume (MB) and/or time (minutes) to allow for enforcement of both quota tracking mechanisms, individually or simultaneously.

When a user consumes the interim total quota or time configured for use during failure handling scenarios, the PCEF shall retry the OCS server to determine if functionality has been restored. In the event that services have been restored, quota assignment and tracking will proceed as per standard usage reporting procedures. Data used during the outage will be reported to the OCS. In the event that the OCS services have not been restored, the PCEF should reallocate with the configured amount of quota and time assigned to the user. The PCEF should report all accumulated used data back to OCS when OCS is back online. If multiple retries and interim allocations occur, the PCEF shall report quota used during all allocation intervals.

When the Gy interface is unavailable, the P-GW shall enter "assume positive" mode. Unique treatment is provided to each subscriber type. Each functional application shall be assigned unique temporary quota volume amounts and time periods based on a command-level AVP from the PCRF on the Gx interface. In addition, a configurable option has been added to disable assume positive functionality for a subscriber group identified by a command-level AVP sent on the Gx interface by the PCRF.

Bit Rate Mapping Across Gx and GTP-based Interfaces

This feature provides for more consistent behavior and ensures correct bandwidth is allocated for bearers.

Bit rate granularity provided by different interfaces was not aligned in 3GPP specifications. For example, the PCRF provided bits per second on the Gx and the GTP utilized kilobits per second. Due to the conversion of bps to kbps, there were scenarios where the rounding off could have resulted in the incorrect allocation of MBR/GBR values.

With this feature, a bitrate value sent on GTP interface will be rounded up if the conversion from bps (received from Gx) to kbps results in a fractional value. However, the enforcement of bitrate value (AMBR, MBR, GBR) values will remain the same. Once the value (in kbps) that is sent towards the Access side, it needs to be rounded up.

This feature (rounding up the bitrate in kbps) will be enabled by default. However, a CLI command under P-GW service, **[no] egtp bitrates-rounded-down-kbps**, controls the behavior of rounding-up. The CLI command enables/disables the old behavior of rounding down. By default, this CLI command is configured to use rounded-up bitrate values. Depending on how the CLI is configured, either rounded-up (Ceil) or rounded-down bitrate value will be sent on GTP interface towards the Access side. If the CLI command is enabled, then it will result in the old behavior. In addition, **show subscribers pgw-only full all** shows the APN-AMBR in terms of bps. Previously, **show subscribers pgw-only full all** used to show in terms of kbps.

CR - C4-132189 - is defined for TS 29.274 for GTP conversion by P-GW.

Backup and Recovery of Key KPI Statistics

Before the Backup and Recovery of Key KPI Statistics feature was implemented, statistics were not backed up and could not be recovered after a SessMgr task restart. Due to this limitation, monitoring the KPI was a problem as the GGSN, P-GW, SAEGW, and S-GW would lose statistical information whenever task restarts occurred.

KPI calculation involves taking a delta between counter values from two time intervals and then determines the percentage of successful processing of a particular procedure in that time interval. When a SessMgr crashes and then recovers, the GGSN, P-GW, SAEGW, and S-GW lose the counter values - they are reset to zero. So, the KPI calculation in the next interval will result in negative values for that interval. This results in a dip in the graphs plotted using the KPI values, making it difficult for operations team to get a consistent view of the network performance to determine if there is a genuine issue or not.

This feature makes it possible to perform reliable KPI calculations even if a SessMgr restart occurs.



Important For more information on Backup and Recovery of Key KPI Statistics, refer to the *Backup and Recovery of Key KPI Statistics* chapter in this guide.

Bulk Statistics Support

The system's support for bulk statistics allows operators to choose to view not only statistics that are of importance to them, but also to configure the format in which it is presented. This simplifies the post-processing of statistical data since it can be formatted to be parsed by external, back-end processors.

When used in conjunction with an element management system (EMS), the data can be parsed, archived, and graphed.

The system can be configured to collect bulk statistics (performance data) and send them to a collection server (called a receiver). Bulk statistics are statistics that are collected in a group. The individual statistics are grouped by schema. Following is a list of supported schemas for P-GW:

- **APN**: Provides Access Point Name statistics
- **APN Expansion**: Provides more granular GTP-C statistics on a per-APN and per-QCI level
- **Card**: Provides card-level statistics
- **Context**: Provides context service statistics
- **Diameter-acct**: Provides Diameter Accounting statistics
- **Diameter-auth**: Provides Diameter Authentication statistics
- **ECS**: Provides Enhanced Charging Service statistics
- **EGTPC**: Provides Evolved GPRS Tunneling Protocol - Control message statistics
- **FA**: Provides FA service statistics
- **GTPC**: Provides GPRS Tunneling Protocol - Control message statistics
- **GTPP**: Provides GPRS Tunneling Protocol - Prime message statistics
- **GTPU**: Provides GPRS Tunneling Protocol - User message statistics
- **HA**: Provides HA service statistics
- **IMSA**: Provides IMS Authorization service statistics
- **IP Pool**: Provides IP pool statistics
- **LMA**: Provides Local Mobility Anchor service statistics
- **P-GW**: Provides P-GW node-level service statistics
- **P-GW eGTP-C S2a**: Provides eGTP-C S2a interface statistics.
- **P-GW eGTP-C S2b**: Provides eGTP-C S2b interface statistics.
- **P-GW eGTP-C S5/S8**: Provides eGTP-C S5/S8 interface statistics.
- **Port**: Provides port-level statistics
- **PPP**: Provides Point-to-Point Protocol statistics
- **RADIUS**: Provides per-RADIUS server statistics
- **System**: Provides system-level statistics

The system supports the configuration of up to 4 sets (primary/secondary) of receivers. Each set can be configured with to collect specific sets of statistics from the various schemas. Statistics can be pulled manually from the system or sent at configured intervals. The bulk statistics are stored on the receiver(s) in files.

The format of the bulk statistic data files can be configured by the user. Users can specify the format of the file name, file headers, and/or footers to include information such as the date, system host name, system uptime, the IP address of the system generating the statistics (available for only for headers and footers), and/or the time that the file was generated.

When an EMS is used as the receiver, it is capable of further processing the statistics data through XML parsing, archiving, and graphing.

The Bulk Statistics Server component of an EMS parses collected statistics and stores the information in the PostgreSQL database. If XML file generation and transfer is required, this element generates the XML output and can send it to a Northbound NMS or an alternate bulk statistics server for further processing.

Additionally, if archiving of the collected statistics is desired, the Bulk Statistics server writes the files to an alternative directory on the server. A specific directory can be configured by the administrative user or the default directory can be used. Regardless, the directory can be on a local file system or on an NFS-mounted file system on an EMS server.



Important For more information on bulk statistic configuration, refer to the *Configuring and Maintaining Bulk Statistics* chapter in the *System Administration Guide*.

Collision Counter Support in GTP Layer

GTPv2 message collisions occur in the network when a node is expecting a particular procedure message from a peer node but instead receives a different procedure message from the peer. The SAEGW software has been enhanced so that these collisions are now tracked by statistics and handled based on a pre-defined action for each message collision type.

If the SAEGW is configured as a pure P-GW or a pure S-GW, operators will still see the respective collision statistics if they occur.

The output of the **show egtpc statistics verbose** command has been enhanced to provide information on GTPv2 message collisions, including:

- **Interface:** The interface on which the collision occurred: SGW (S4/S11), SGW (S5), or PGW (S5).
- **Old Proc (Msg Type):** Indicates the ongoing procedure at eGTP-C when a new message arrived at the interface which caused the collision. The Msg Type in brackets specifies which message triggered this ongoing procedure.
- **New Proc (Msg Type):** The new procedure and message type.
- **Action:** The pre-defined action taken to handle the collision. The action can be one of:
 - **No Collision Detected**
 - **Suspend Old:** Suspend processing of the original (old) message, process the new message, then resume old message handling.
 - **Abort Old:** Abort the original message handling and processes the new message.
 - **Reject New:** The new message is rejected, and the original (old) message is processed.
 - **Silent Drop New:** Drop the new incoming message, and the old message is processed.
 - **Parallel Hndl:** Both the original (old) and new messages are handled in parallel.
 - **Buffer New:** The new message is buffered and processed once the original (old) message processing is done.
- **Counter:** The number of times each collision type has occurred.



Important The Message Collision Statistics section of the command output only appears if any of the collision statistics have a counter total that is greater than zero.

Sample output:

```

Message Collision Statistics
  Interface      Old Proc (Msg Type)      New Proc (Msg Type)      Action
Counter
  SGW(S5)      NW Init Bearer Create (95)  NW Init PDN Delete (99)  Abort Old      1

```

In this instance, the output states that at the S-GW egress interface (S5) a Bearer creation procedure is going on due to a CREATE BEARER REQUEST(95) message from the P-GW. Before its response comes to the S-GW from the MME, a new procedure PDN Delete is triggered due to a DELETE BEARER REQUEST(99) message from the P-GW.

The action that is carried out due to this collision at eGTP-C is to abort (Abort Old) the Bearer Creation procedure and carry on normally with the PDN Delete procedure. The Counter total of 1 indicates that this collision happened only once.

Congestion Control

The congestion control feature allows you to set policies and thresholds and specify how the system reacts when faced with a heavy load condition.

Congestion control monitors the system for conditions that could potentially degrade performance when the system is under heavy load. Typically, these conditions are temporary (for example, high CPU or memory utilization) and are quickly resolved. However, continuous or large numbers of these conditions within a specific time interval may have an impact the system's ability to service subscriber sessions. Congestion control helps identify such conditions and invokes policies for addressing the situation.

Congestion control operation is based on configuring the following:

- **Congestion Condition Thresholds:** Thresholds dictate the conditions for which congestion control is enabled and establishes limits for defining the state of the system (congested or clear). These thresholds function in a way similar to operation thresholds that are configured for the system as described in the Thresholding Configuration Guide. The primary difference is that when congestion thresholds are reached, a service congestion policy and an SNMP trap, starCongestion, are generated.

A threshold tolerance dictates the percentage under the configured threshold that must be reached in order for the condition to be cleared. An SNMP trap, starCongestionClear, is then triggered.

- **Port Utilization Thresholds:** If you set a port utilization threshold, when the average utilization of all ports in the system reaches the specified threshold, congestion control is enabled.
 - **Port-specific Thresholds:** If you set port-specific thresholds, when any individual port-specific threshold is reached, congestion control is enabled system-wide.
- **Service Congestion Policies:** Congestion policies are configurable for each service. These policies dictate how services respond when the system detects that a congestion condition threshold has been crossed.



Important For more information on congestion control, refer to the *Congestion Control* chapter in the *System Administration Guide*.

Default and Dedicated EPC Bearers

Provides a foundation for contributing towards improved Quality of User Experience (QoE) by enabling deterministic end-to-end forwarding and scheduling treatments for different services or classes of applications pursuant to their requirements for committed bandwidth resources, jitter and delay. In this way, each application receives the service treatment that users expect.

In the StarOS 9.0 release, the Cisco EPC core platforms support one or more EPS bearers (default plus dedicated). An EPS bearer is a logical aggregate of one or more Service Data Flows (SDFs), running between a UE and a P-GW in the case of a GTP-based S5/S8 interface, and between a UE and HSGW (HRPD Serving Gateway) in case of a PMIP-based S2a interface. In networks where GTP is used as the S5/S8 protocol, the EPS bearer constitutes a concatenation of a radio bearer, S1-U bearer and an S5/S8 bearer anchored on the P-GW. In cases where PMIPv6 is used the EPS bearer is concatenated between the UE and HSGW with IP connectivity between the HSGW and P-GW.

Note: This release supports only GTP-based S5/S8 and PMIPv6 S2a capabilities with no commercial support for PMIPv6 S5/S8.

An EPS bearer uniquely identifies traffic flows that receive a common QoS treatment between a UE and P-GW in the GTP-based S5/S8 design, and between a UE and HSGW in the PMIPv6 S2a approach. If different QoS scheduling priorities are required between Service Data Flows, they should be assigned to separate EPS bearers. Packet filters are signaled in the NAS procedures and associated with a unique packet filter identifier on a per-PDN connection basis.

One EPS bearer is established when the UE connects to a PDN, and that remains established throughout the lifetime of the PDN connection to provide the UE with always-on IP connectivity to that PDN. That bearer is referred to as the default bearer. A PDN connection represents a traffic flow aggregate between a mobile access terminal and an external Packet Data Network (PDN) such as an IMS network, a walled garden application cloud or a back-end enterprise network. Any additional EPS bearer that is established to the same PDN is referred to as a dedicated bearer. The EPS bearer Traffic Flow Template (TFT) is the set of all 5-tuple packet filters associated with a given EPS bearer. The EPC core elements assign a separate bearer ID for each established EPS bearer. At a given time a UE may have multiple PDN connections on one or more P-GWs.

DHCP Support

The P-GW supports dynamic IP address assignment to subscriber IP PDN contexts using the Dynamic Host Control Protocol (DHCP), as defined by the following standards:

- RFC 2131, Dynamic Host Configuration Protocol
- RFC 2132, DHCP Options and BOOTP Vendor Extensions

The method by which IP addresses are assigned to a PDN context is configured on an APN-by-APN basis. Each APN template dictates whether it will support static or dynamic addresses. Dynamically assigned IP addresses for subscriber PDN contexts can be assigned through the use of DHCP.

The P-GW acts as a DHCP server toward the UE and a DHCP client toward the external DHCP server. The DHCP server function and DHCP client function on the P-GW are completely independent of each other; one can exist without the other.

DHCP supports both IPv4 and IPv6 addresses.

The P-GW does not support DHCP-relay.

Deferred IPv4 Address Allocation

Apart from obtaining IP addresses during initial access signaling, a UE can indicate via PCO options that it prefers to obtain IP address and related configuration via DHCP after default bearer has been established. This is also known as Deferred Address Allocation.

IPv4 addresses are becoming an increasingly scarce resource. Since 4G networks like LTE are always on, scarce resources such as IPv4 addresses cannot/should not be monopolized by UEs when they are in an ECM-IDLE state.

PDN-type IPv4v6 allows a dual stack implementing. The P-GW allocates an IPv6 address only by default for an IPv4v6 PDN type. The UE defers the allocation of IPv4 addresses based upon its needs, and relinquishes any IPv4 addresses to the global pool once it is done. The P-GW may employ any IPv4 address scheme (local pool or external DHCP server) when providing an IPv4 address on demand.

Support for Option 26 in DHCP

While fetching IPv4 address for the UE, P-GW acts as an independent DHCP server and client at the same time. It acts as a DHCP server towards the UE and as DHCP client towards the external DHCP server. In earlier release, support for exchange of certain DHCP options between the UE and the external DHCP server through the P-GW was added. This included support for relaying certain external DHCP server provided options (1, 3, 6, 28, and 43) to the UE along with the IPv4 address when deferred address allocation was configured with IP-Addralloc Proxy mode.

This feature adds support for Option 26 received in DHCP OFFER message from the DHCP server.

P-GW preserved the exchanged DHCP option 26 between the UE and the external DHCP server. P-GW relays this option for any future message exchanges between the UE and the external DHCP server. The external DHCP server component of the P-GW reserves and maintains the external DHCP server provided DHCP option so that when the UE renews or rebinds the DHCP lease, P-GW responds with the preserved value.

This feature introduces a behavior change with respect to renewal request. Earlier, when the ASR5500 was configured in DHCP proxy mode and when the DHCP server did not respond to a renewal request, a retransmission at time T_2 ($.85 * \text{lease time}$) did not include both of the configured DHCP servers. DHCP lease got expired after retries exhaustion in the RENEW state.

With this feature, suppose the number of retransmission is configured as 2, then in RENEW state maximum 2 retries are done for the DHCP request messages. If no response is received from the DHCP server and state is changed to REBIND then also DHCP request messages is retried 2 times.

Old Behavior: Earlier, for lower values of "number of retransmission" (example ≥ 2), DHCP request message was not retried in the REBIND state.

New Behavior: Now, DHCP request message is retried for the number of times it is configured in both RENEW and REBIND state.

DHCPv6 Support

The Dynamic Host Configuration Protocol (DHCP) for IPv6 enables the DHCP servers to pass the configuration parameters, such as IPv6 network addresses to IPv6 nodes. It offers the capability of allocating the reusable network addresses and additional configuration functionality automatically.

The DHCPv6 support does not just feature the address allocation, but also fulfills the requirements of Network Layer IP parameters. Apart from these canonical usage modes, DHCPv6's Prefix-Delegation (DHCP-PD) has also been standardized by 3GPP (Rel 10) for "network-behind-ue" scenarios.

P-GW manages IPv6 prefix life-cycle just like it manages IPv4 addresses, thus it is responsible for allocation, renew, and release of these prefixes during the lifetime of a session. IPv6 Prefix is mainly for the UE's session attached to P-GW, where as delegated prefix is for network/devices behind UE. For IPv6 prefixes. P-GW may be obtained from either local-pool, AAA (RADIUS/DIAMETER) or external DHCPv6 servers based on respective configuration. For Delegated IPv6 Prefix allocation, P-GW obtained it from external DHCPv6 servers based on configuration.

Unicast Address Support Feature: The IPv6 prefix delegation for the requested UE is either allocated locally or from an external DHCPv6 server by P-GW, GGSN, SAEGW based on configuration at these nodes. These DHCP messages are sent to the external DHCPv6 server using multicast address as destination address. In networks where there are large number of P-GW servers, but less number of DHCP servers, the DHCPv6 messages with multicast address have to travel through the entire network, increasing load on the network. The Unicast address support feature enables the operator to send all DHCPv6 messages on unicast address towards external server using configured address of DHCPv6 server in a DHCP service. This feature is CLI controlled and the operator needs to configure a CLI to support for client unicast operation to the DHCP Server.

DHCPv6 support for P-GW covers the following requirements:

- RFC 3315, Dynamic Host Configuration Protocol for IPv6 (Basic DHCPv6)
- RFC 3633, prefix delegation mechanism

Direct Tunnel Support

When Gn/Gp interworking with pre-release SGSNs is enabled, the GGSN service on the P-GW supports direct tunnel functionality.

Direct tunnel improves the user experience (e.g. expedited web page delivery, reduced round trip delay for conversational services, etc.) by eliminating SGSN tunnel "switching" latency from the user plane. An additional advantage of direct tunnel from an operational and capital expenditure perspective is that direct tunnel optimizes the usage of user plane resources by removing the requirement for user plane processing on the SGSN.

The direct tunnel architecture allows the establishment of a direct user plane tunnel between the RAN and the GGSN, bypassing the SGSN. The SGSN continues to handle the control plane signaling and typically makes the decision to establish direct tunnel at PDP Context Activation. A direct tunnel is achieved at PDP context activation by the SGSN establishing a user plane (GTP-U) tunnel directly between RNC and GGSN (using an Update PDP Context Request toward the GGSN).

A major consequence of deploying direct tunnel is that it produces a significant increase in control plane load on both the SGSN and GGSN components of the packet core. It is therefore of paramount importance to a wireless operator to ensure that the deployed GGSNs are capable of handling the additional control plane loads introduced of part of direct tunnel deployment. The Cisco GGSN and SGSN offer massive control plane transaction capabilities, ensuring system control plane capacity will not be a capacity limiting factor once direct tunnel is deployed.



Important For more information on direct tunnel support, refer to the *Direct Tunnel for 4G (LTE) Networks* chapter in this guide.

DNS Support for IPv4/IPv6 PDP Contexts

This feature adds functionality in P-GW for PDN type IPv4v6. in StarOS Release 15.0. Previously, if an MS requested an IPv4 DNS address, P-GW did not send the IPv4 DNS address.

MS may request for DNS server IPv4 or IPv6 addresses using the Protocol Configurations Options IE (as a container or as part of IPCP protocol configuration request) in PDP Context Activation procedure for PDP Type IPv4, IPv6, or IPv4v6. In that case, the P-GW may return the IP address of one or more DNS servers in the PCO IE in the PDP Context Activation Response message. The DNS address(es) shall be coded in the PCO as specified in 3GPP TS 24.008.

For PDP Type IPv4v6, if MS requested DNS server IPv4 address, it did not return an IPv4 address. Support is now added to respond with address requested by MS.

AAA server may also provide DNS Server IP Address in Access-Accept Auth Response. In such cases, AAA provided DNS server IPs takes priority over the one configured under APN.

When DNS server address is requested in PCO configuration, the following preference would be followed:

1. DNS values received from RADIUS Server.
2. DNS values locally configured with APN.
3. DNS values configured at context level with **ip name-servers** CLI.

Domain Based Flow Definitions

This solution provides improved flexibility and granularity in obtaining geographically correct exact IP entries of the servers by snooping DNS responses.

Currently, it is possible to configure L7 rules to filter based on domain (m.google.com). Sometimes multiple servers may serve a domain, each with its own IP address. Using an IP-rule instead of an http rule will result in multiple IP-rules; one IP-rule for each server "behind" the domain, and it might get cumbersome to maintain a list of IP addresses for domain-based filters.

In this solution, you can create ruledefs specifying hostnames (domain names) and parts of hostnames (domain names). Upon the definition of the hostnames/domain names or parts of them, the P-GW will monitor all the DNS responses sent towards the UE and will snoop only the DNS response, which has q-name or a-name as specified in the rules, and identify all the IP addresses resulted from the DNS responses. DNS snooping will be done on live traffic for every subscriber.

DSCP Marking

Provides support for more granular configuration of DSCP marking.

For Interactive Traffic class, the P-GW supports per-gateway service and per-APN configurable DSCP marking for Uplink and Downlink direction based on Allocation/Retention Priority in addition to the current priorities.

The following matrix may be used to determine the Diffserv markings used based on the configured traffic class and Allocation/Retention Priority:

Table 6: Default DSCP Value Matrix

Allocation Priority	1	2	3
Traffic Handling Priority			

Allocation Priority	1	2	3
1	ef	ef	ef
2	af21	af21	af21
3	af21	af21	af21

In addition, the P-GW allows configuration of diameter packets and GTP-C/GTP-U echo with DSCP values.

RAT-Type based DSCP Marking

With 21.6 and later releases, operators can perform DSCP marking on gateways such as GGSN, P-GW, and SAE-GW, based on RAT-Type. It allows the operator to configure different QoS services and to optimize traffic based on the RAT-Type: EUTRAN, GERAN, and UTRAN.

RAT-Type based DSCP marking includes the following:

- Support for all QCI and ARP values.
- Support for Standard and non-Standard QCIs.
- If a particular RAT-Type is not configured, the DSCP marking functionality is applied to all RAT-Type.
- Applicable for Virtual APNs.
- During Inter-RAT hand-offs, DSCP marking is based on the RAT-Type of the current hand-off.
- DSCP marking per RAT-Type is only applicable for user data traffic and not for control traffic (GTP-C packets).



Important Backward compatibility is maintained for existing DSCP marking and IP-ToS functionalities.

GTP-U on per APN Basis

This feature provides the flexibility to have a different DSCP marking table on per APN basis so that traffic on each of the APNs can be marked differently, depending on the needs of the APN.

The S-GW/P-GW supports configurable DSCP marking of the outer header of a GTP-U tunnel packet based on a QCI/THP table for the S5/S8 and Gn/Gp interfaces. This feature allows configuring DSCP marking table on a per APN basis.

Previously, DSCP marking table was configured on P-GW service level. As part of this requirement, CLI was added to associate the qos-qci-mapping table in APN.



Important The SAEGW does not support non-standard QCI values. QCI values 1 through 9 are standard values and are defined in 3GPP TS 23.203; the SAEGW supports these standard values.

In order to be backward compatible with older configurations, if a DSCP marking table is associated with P-GW service and not with the APN, then the one in P-GW service will be used. If table is associated in both P-GW service and APN, then the one on APN will take precedence.

Dynamic GTP Echo Timer

The Dynamic GTP Echo Timer enables the eGTP and GTP-U services to better manage GTP paths during network congestion. As opposed to the default echo timer, which uses fixed intervals and retransmission timers, the dynamic echo timer adds a calculated round trip timer (RTT) that is generated once a full request/response procedure has completed. A multiplier can be added to the calculation for additional support during congestion periods.



Important For more information, refer to the *Configuring the GTP Echo Timer* section located in the *Configuring Optional Features on the P-GW* section of the *PDN Gateway Configuration* chapter.

Dynamic Policy Charging Control (Gx Reference Interface)

Dynamic policy and charging control provides a primary building block toward the realization of IMS multimedia applications. In contrast to statically provisioned architectures, the dynamic policy framework provides a centralized service control layer with global awareness of all access-side network elements. The centralized policy decision elements simplify the process of provisioning global policies to multiple access gateways. Dynamic policy is especially useful in an Always-On deployment model as the usage paradigm transitions from a short lived to a lengthier online session in which the volume of data consumed can be extensive. Under these conditions dynamic policy management enables dynamic just in-time resource allocation to more efficiently protect the capacity and resources of the network.

Dynamic Policy Control represents the ability to dynamically authorize and control services and application flows between a Policy Charging Enforcement Function (PCEF) on the P-GW and the PCRF. Policy control enables a centralized and decoupled service control architecture to regulate the way in which services are provisioned and allocated at the bearer resource layer.

The StarOS 9.0 release included enhancements to conform with 3GPP TS 29.212 and 29.230 functions. The Gx reference interface uses Diameter transport and IPv6 addressing. The subscriber is identified to the PCRF at session establishment using IMSI based NAIs within the Subscription-ID AVP. Additionally the IMEI within the Equipment-Info AVP is used to identify the subscriber access terminal to the policy server. The Gx reference interface supports the following capabilities:

- Authorize the bearer establishment for a packet flow
- Dynamic L3/L4 transfer of service data flow filters within PCC rules for selection and policy enforcement of downlink/uplink IP CAN bearers
- Support static pre-provisioned L7 rulebase name attribute as trigger for activating Inline Services such as Peer-to-Peer Detection
- Authorize the modification of a service data flow
- Revoke the authorization of a packet flow
- Provision PCC rules for service data flows mapped to default or dedicated EPS bearers
- Support P-GW initiated event triggers based on change of access network gateway or IP CAN
- Provide the ability to set or modify APN-AMBR for a default EPS bearer
- Create or modify QoS service priority by including QCI values in PCC rules transmitted from PCRF to PCEF functions

Enhanced Charging Service (ECS)

The Enhanced Charging Service provides an integrated in-line service for inspecting subscriber data packets and generating detail records to enable billing based on usage and traffic patterns. Other features include:

- [Content Analysis Support, on page 68](#)
- [Content Service Steering, on page 69](#)
- [Support for Multiple Detail Record Types, on page 70](#)
- [Diameter Credit Control Application, on page 70](#)
- [Accept TCP Connections from DCCA Server, on page 71](#)
- [Gy Interface Support, on page 71](#)

The Enhanced Charging Service (ECS) is an in-line service feature that is integrated within the system. ECS enhances the mobile carrier's ability to provide flexible, differentiated, and detailed billing to subscribers by using Layer 3 through Layer 7 deep packet inspection with the ability to integrate with back-end billing mediation systems.

ECS interacts with active mediation systems to provide full real-time prepaid and active charging capabilities. Here the active mediation system provides the rating and charging function for different applications.

In addition, ECS also includes extensive record generation capabilities for post-paid charging with in-depth understanding of the user session. Refer to the Support for Multiple Detail Record Types section for more information.

The major components include:

- **Service Steering:** Directs subscriber traffic into the ECS subsystem. Service Steering is used to direct selective subscriber traffic flows via an Access Control List (ACL). It is used for other redirection applications as well for both internal and external services and servers.
- **Protocol Analyzer:** The software stack responsible for analyzing the individual protocol fields and states during packet inspection. It performs two types of packet inspection:
 - **Shallow Packet Inspection:** inspection of the layer 3 (IP header) and layer 4 (e.g. UDP or TCP header) information.
 - **Deep Packet Inspection:** inspection of layer 7 and 7+ information. Deep packet inspection functionality includes:
 - Detection of URI (Uniform Resource Identifier) information at level 7 (e.g., HTTP, WTP, RTSP Uniform Resource Locators (URLs)).
 - Identification of true destination in the case of terminating proxies, where shallow packet inspection would only reveal the destination IP address / port number of a terminating proxy.
 - De-encapsulation of upper layer protocol headers, such as MMS-over-WTP, WSP-over-UDP, and IP-over GPRS.
 - Verification that traffic actually conforms to the protocol the layer 4 port number suggests.
- **Rule Definitions:** User-defined expressions, based on protocol fields and/or protocol-states, which define what actions to take when specific field values are true. Expressions may contain a number of operator types (string, =, >, etc.) based on the data type of the operand. Each Ruledef configuration is consisting of multiple expressions applicable to any of the fields or states supported by the respective analyzers.

- **Rule Bases:** a collection of rule definitions and their associated billing policy. The rule base determines the action to be taken when a rule is matched. It is possible to define a rule definition with different actions.

Mediation and Charging Methods

To provide maximum flexibility when integrating with billing mediation systems, ECS supports a full range of charging and authorization interfaces.

- **Pre-paid:** In a pre-paid environment, the subscribers pay for service prior to use. While the subscriber is using the service, credit is deducted from subscriber's account until it is exhausted or call ends. The pre-paid accounting server is responsible for authorizing network nodes (GGSNs) to grant access to the user, as well as grant quotas for either time connected or volume used. It is up to the network node to track the quota use, and when these use quotas run low, the network node sends a request to the pre-paid server for more quota.

If the user has not used up the purchased credit, the server grants quota and if no credit is available to the subscriber the call will be disconnected. ECS and DCCA manage this functionality by providing the ability to setup quotas for different services.

Pre-paid quota in ECS is implemented using DIAMETER Credit Control Application (DCCA). DCCA supports the implementation of real-time credit control for a variety of services, such as networks access, messaging services, and download services.

In addition to being a general solution for real-time cost and credit control, DCCA includes these features:

- **Real-time Rate Service Information** - DCCA can verify when end subscribers' accounts are exhausted or expired; or deny additional chargeable events.
- **Support for Multiple Services** - DCCA supports the usage of multiple services within one subscriber session. Multiple Service support includes; 1) ability to identify and process the service or group of services that are subject to different cost structures 2) independent credit control of multiple services in a single credit control sub-session.

Refer to [Diameter Credit Control Application, on page 70](#) for more information.

- **Post-paid:** In a post-paid environment, the subscribers pay after use of the service. A AAA server is responsible for authorizing network nodes (GGSNs) to grant access to the user and a CDR system generates G-CDRs/eG-CDRs/EDRs/UDRs or Comma Separated Values (CSVs) for billing information on pre-defined intervals of volume or per time.



Important

Support for the Enhanced Charging Service requires a service license; the ECS license is included in the P-GW session use license. For more information on ECS, refer to the *Enhanced Charging Service Administration Guide*.

Content Analysis Support

The Enhanced Charging Service is capable of performing content analysis on packets of many different protocols at different layers of the OSI model.

The ECS content analyzers are able to inspect and maintain state across various protocols at all layers of the OSI stack. ECS system supports, inspects, and analyzes the following protocols:

- IP
- TCP
- UDP
- DNS
- FTP
- TFTP
- SMTP
- POP3
- HTTP
- ICMP
- WAP: WTP and WSP
- Real-Time Streaming: RTP and RTSP
- MMS
- SIP and SDP
- File analysis: examination of downloaded file characteristics (e.g. file size, chunks transferred, etc.) from file transfer protocols such as HTTP and FTP.

Traffic analyzers in enhanced charging subsystem are based on configured rules. Rules used for Traffic analysis analyze packet flows and form usage records. Usage records are created per content type and forwarded to a pre-paid server or to a mediation/billing system. A traffic analyzer performs shallow (Layer 3 and Layer 4) and deep (above Layer 4) packet inspection of the IP packet flows.

The Traffic Analyzer function is able to do a shallow (layer 3 and layer 4) and deep (above layer 4) packet inspection of IP Packet Flows.

It is able to correlate all layer 3 packets (and bytes) with higher layer trigger criteria (e.g. URL detected in a HTTP header) and it is also perform stateful packet inspection to complex protocols like FTP, RTSP, SIP that dynamically open ports for the data path and by this way, user plane payload is differentiated into "categories".

The Traffic Analyzer works on the application level as well and performs event based charging without the interference of the service platforms.



Important This functionality is available for use with the Enhanced Charging Service which requires a session-use license. For more information on ECS, refer to the *Enhanced Charging Service Administration Guide*.

Content Service Steering

Content Service Steering (CSS) directs selective subscriber traffic into the ECS subsystem (In-line services internal to the system) based on the content of the data presented by mobile subscribers.

CSS uses Access Control Lists (ACLs) to redirect selective subscriber traffic flows. ACLs control the flow of packets into and out of the system. ACLs consist of "rules" (ACL rules) or filters that control the action taken on packets matching the filter criteria.

ACLs are configurable on a per-context basis and applies to a subscriber through either a subscriber profile or an APN profile in the destination context.



Important For more information on CSS, refer to the *Content Service Steering* chapter of the *System Administration Guide*.



Important For more information on ACLs, refer to the *IP Access Control Lists* chapter of the *System Administration Guide*.

Support for Multiple Detail Record Types

To meet the requirements of standard solutions and at the same time, provide flexible and detailed information on service usage, the Enhanced Charging Service (ECS) provides the following type of usage records:

- Event Detail Records (EDRs)
- Usage Detail Records (UDRs)

ECS provides for the generation of charging data files, which can be periodically retrieved from the system and used as input to a billing mediation system for post-processing. These files are provided in a standard format, so that the impact on the existing billing/mediation system is minimal and at the same time, these records contain all the information required for billing based on the content.

GTPP accounting in ECS allows the collection of counters for different types of data traffic into detail records. The following types of detail records are supported:

- **Event Detail Records (EDRs):** An alternative to standard G-CDRs when the information provided by the G-CDRs is not sufficient to do the content billing. EDRs are generated according to explicit action statements in rule commands that are user-configurable. The EDRs are generated in comma separated values (CSV) format, generated as defined in traffic analysis rules.
- **User Detail Records (UDRs):** Contain accounting information related to a specific mobile subscriber. The fields to be reported in them are user-configurable and are generated on any trigger of time threshold, volume threshold, handoffs, and call termination. The UDRs are generated in comma separated values (CSV) format, generated as defined in traffic analysis rules.



Important This functionality is available for use with the Enhanced Charging Service which requires a session-use license. For more information on ECS, refer to the *Enhanced Charging Service Administration Guide*.

Diameter Credit Control Application

Provides a pre-paid billing mechanism for real-time cost and credit control based on the following **standards**:

- RFC 3588, Diameter Base Protocol, September 2003
- RFC 4006, Diameter Credit-Control Application, August 2005

The Diameter Credit Control Application (DCCA) is used to implement real-time credit-control for a variety of end user services such as network access, Session Initiation Protocol (SIP) services, messaging services, download services etc.

Used in conjunction with ECS, the DCCA interface uses a mechanism to allow the user to be informed of the charges to be levied for a requested service. In addition, there are services such as gaming and advertising that may credit as well as debit from a user account.

DCCA also supports the following:

- **Real-time Rate Service Information:** The ability to verify when end subscribers' accounts are exhausted or expired; or deny additional chargeable events.
- **Support for Multiple Services:** The usage of multiple services within one subscriber session is supported. Multiple Service support includes:
 - The ability to identify and process the service or group of services that are subject to different cost structures.
 - Independent credit control of multiple services in a single credit control sub-session.



Important

This functionality is available for use with the Enhanced Charging Service, which requires a session-use license. For more information on ECS, refer to the *Enhanced Charging Service Administration Guide*.

Accept TCP Connections from DCCA Server

This feature allows for peer Diameter Credit Control Application servers to initiate a connection the NGME.

This feature allows peer diameter nodes to connect to the NGME on TCP port 3868 when the diameter server is incapable of receiving diameter incoming diameter requests.



Important

For more information on Diameter support, if you are using StarOS 12.3 or an earlier release, refer to the *AAA and GTPP Interface Administration and Reference*. If you are using StarOS 14.0 or a later release, refer to the *AAA Interface Administration and Reference*.

Gy Interface Support

The Gy interface enables the wireless operator to implement a standardized interface for real time content based charging with differentiated rates for time based and volume based charging.

As it is based on a quota mechanism, the Gy interface enables the wireless operator to spare expensive Prepaid System resources.

As it enables time-, volume-, and event-based charging models, the Gy interface flexibly enables the operator to implement charging models tailored to their service strategies.

The Gy interface provides a standardized Diameter interface for real time content based charging of data services. It is based on the 3GPP standards and relies on quota allocation.

It provides an online charging interface that works with the ECS deep packet inspection feature. With Gy, customer traffic can be gated and billed in an "online" or "prepaid" style. Both time- and volume-based

charging models are supported. In all of these models, differentiated rates can be applied to different services based on shallow or deep packet inspection.

Gy is a Diameter interface. As such, it is implemented atop, and inherits features from, the Diameter Base Protocol. The system supports the applicable Base network and application features, including directly connected, relayed or proxied DCCA servers using TLS or plaintext TCP.

In the simplest possible installation, the system exchanges Gy Diameter messages over Diameter TCP links between itself and one "prepay" server. For a more robust installation, multiple servers would be used. These servers may optionally share or mirror a single quota database so as to support Gy session failover from one server to the other. For a more scalable installation, a layer of proxies or other Diameter agents can be introduced to provide features such as multi-path message routing or message and session redirection features.

The Cisco implementation is based on the following standards:

- RFC 4006 generic DCCA, including:
 - CCR Initial, Update, and Final signaling
 - ASR and RAR asynchronous DCCA server messages
 - Time, Total-Octets, and Service-Specific-Units quota management
 - Multiple independent quotas using Multiple-Services-Credit-Control
 - Rating-Group for quota-to-traffic association
 - CC-Failure-Handling and CC-Session-Failover features
 - Final-Unit-Action TERMINATE behavior
 - Tariff-Time-Change feature.
- 3GPP TS 32.299 online mode "Gy" DCCA, including:
 - Final-Unit-Action REDIRECT behavior
 - Quota-Holding-Time: This defines a user traffic idle time, on a per category basis, after which the usage is returned and no new quota is explicitly requested
 - Quota-Thresholds: These AVPs define a low value watermark at which new quota will be sought before the quota is entirely gone; the intent is to limit interruption of user traffic.
 - These AVPs exist for all quota flavors, for example "Time-Quota-Threshold".
 - Trigger-Type: This AVP defines a set of events which will induce a re-authentication of the current session and its quota categories.

Enhancement to New Call Setup after Sessmgr or DPC Failure

This enhancement is used to address some specific failure scenarios where either the sessmgr or the corresponding aaa manager restarts, and the P-GW service/sessmgr is unable to bring new calls up or establish a connection with all other dependent services. In these failure scenarios if a call landed on this particular P-GW service/sessmgr, the call establishment is significantly delayed and would fail until all the dependent services come up. This resulted in the possibility that the S-GW might time out and report that the peer P-GW is not responding to the Create Session Request (CSReq) message.

Prior to StarOS release 20, the demux did not prevent a sessmgr from accepting new calls even after a sessmgr restart had occurred, which then placed the sessmgr in a state where it was unable to accept new calls.

Although the issue is usually self-correcting and takes between 10 to 25 seconds to complete, if operators see too many call rejects due to a peer not responding to the Create Session Response (CSResp) message, and this is happening after a aaa manager restart or a sessmgr restart, the SAEGW can be configured via the CLI to temporarily stop seeing the peer not responding error. By enabling this new CLI-controlled feature, the demuxmgr will prevent the sessmgr from accepting new calls for a configured amount of time, after which the sessmgrs will restart.

Use the **require demux smgr-suspension interval** command in Global Configuration Mode to address these scenarios when they occur.

Framed-Route Attribute Support

The Framed-Route attribute provides routing information to be configured for the user on the network access server (NAS). The Framed-Route information is returned to the RADIUS server in the Access-Accept message.

Mobile Router enables a router to create a PDN Session which the P-GW authorizes using RADIUS server. The RADIUS server authenticates this router and includes a Framed-Route attribute in the access-accept response packet. Framed-Route attribute also specifies the subnet routing information to be installed in the P-GW for the "mobile router." If the P-GW receives a packet with a destination address matching the Framed-Route, the packet is forwarded to the mobile router through the associated PDN Session. For more information, see *Routing Behind the Mobile Station on an APN* chapter.

Gn/Gp Handoff Support

Integrated support of this feature requires that a valid session use license key be installed for both P-GW and GGSN. Contact your local Sales or Support representative for information on how to obtain a license.

In LTE deployments, smooth handover support is required between 3G/2G and LTE networks, and Evolved Packet Core (EPC) is designed to be a common packet core for different access technologies. P-GW supports handovers as user equipment (UE) moves across different access technologies.

Cisco's P-GW supports inter-technology mobility handover between 4G and 3G/2G access. Interworking is supported between the 4G and 2G/3G SGSNs, which provide only Gn and Gp interfaces but no S3, S4 or S5/S8 interfaces. These Gn/Gp SGSNs provide no functionality introduced specifically for the evolved packet system (EPS) or for interoperation with the E-UTRAN. These handovers are supported only with a GTP-based S5/S8 and P-GW supports handoffs between GTPv2 based S5/S8 and GTPv1 based Gn/Gp tunneled connections. In this scenario, the P-GW works as an IP anchor for the EPC.



Important

To support the seamless handover of a session between GGSN and P-GW, the two independent services must be co-located on the same node and configured within the same context for optimum interoperation.



Important

For more information on Gn/GP handoffs, refer to *Gn/Gp GGSN/SGSN (GERAN/UTRAN)* in the *Supported Logical Network Interfaces (Reference Points)* section in this chapter.

GTP-C Path Failure Enhancements and Improved Debugging Tools

In StarOS release 20.0, enhancements have been added to optimize GTP-C path failure functionality, and to improve the debug capability of the system for GTP-C path failure problems. These features will help Operators and Engineers to debug different aspects of the system that will help in identifying the root cause of GTP-C path failures in the network. These enhancements affect path failure detection via the s5, s8, s2b, and s2a interfaces.

The following enhancements are added as part of this feature:

- The node can be configured so that it does not detect a path failure if a low restart counter is received due to incorrect or spurious messages. This prevents call loss. The option to disable path failure due to Echo Request/Response and Control Message Request/Response messages is also available so that call loss is prevented in the event of a false path failure detection.
- More granularity has been added to GTP-C path failure statistics so that the root cause of issues in the network can be diagnosed more quickly.
- A path failure history for the last five path failures per peer is available to assist in debugging path failures in the network.
- Seamless path failure handling is implemented so that call loss is avoided during redundancy events.

Support to Avoid False Path Failure Detection

Several enhancements have been made to facilitate the node's ability to avoid false path failure detection:

- The software has been enhanced to avoid path failure detection due to spurious/incorrect messages from a peer. These messages can cause a large burst in network traffic due to the number of service deactivations and activations, resulting in network congestion. The **gtpc** command in *eGTP-C Service Configuration Mode* has been enhanced to resolve this issue. The **max-remote-restart-counter-change** keyword has been added to ensure false path failure detections are not detected as GTP-C path failures. For example, if the **max-remote-restart-counter-change** is set to 10 and the current peer restart counter is 251, eGTP will detect a peer restart only if the new restart counter is 252 through 255 or 0 through 5. Similarly, if the stored restart counter is 1, eGTP will detect a peer restart only if the new restart counter is 2 through 11.
- Also as part of this enhancement, new keywords have been added to the **path-failure-detection-policy** command in *eGTP-C Service Configuration Mode* to enable or disable path failure detection.
- The **show egtp-service all** command in Exec Mode has been enhanced to indicate whether Echo Request/Echo Response Restart Counter Change and Control Message Restart Counter Change are enabled/disabled on the node.

Improved GTP-C Path Failure Statistics

Several improvements have been made to improve the quality of the GTP-C path failures so that operators/engineers can more quickly identify the cause of the failure.

- The output of the **show egtpc statistics path-failure-reasons** has been enhanced to show the number and type of control message restart counter changes at the demuxmgr and sessmgr. This command output has also been enhanced to track the number of path failures detected that were ignored at the eGTP-C layer.

- The **show egtpc peers path-failure-history** command output has been added to provide detailed information on the last five path failures per peer.
- The output of the **show egtpc-service all name** and **show configuration** commands has been enhanced to show the current configuration settings specific to path GTP-C path failure detection policy.

IMS Emergency Bearer Handling

With this support, a UE is able to connect to an emergency PDN and make Enhanced 911 (E911) calls while providing the required location information to the Public Safety Access Point (PSAP).

E911 is a telecommunications-based system that is designed to link people who are experiencing an emergency with the public resources that can help. This feature supports E911-based calls across the LTE and IMS networks. In a voice over LTE scenario, the subscriber attaches to a dedicated packet data network (PDN) called EPDN (Emergency PDN) in order to establish a voice over IP connection to the PSAP. Signaling either happens on the default emergency bearer, or signaling and RTP media flow over separate dedicated emergency bearers. Additionally, different than normal PDN attachment that relies on AAA and PCRF components for call establishment, the EPDN attributes are configured locally on the P-GW, which eliminates the potential for emergency call failure if either of these systems is not available.

Emergency bearer services are provided to support IMS emergency sessions. Emergency bearer services are functionalities provided by the serving network when the network is configured to support emergency services. Emergency bearer services are provided to normally attached UEs and to UEs that are in a limited service state (depending on local service regulations, policies, and restrictions). Receiving emergency services in limited service state does not require a subscription.

The standard (refer to 3GPP TS 23.401) has identified four behaviors that are supported:

- Valid UEs only
- Authenticated UEs only
- MSI required, authentication optional
- All UEs

To request emergency services, the UE has the following two options:

- UEs that are in a limited service state (due to attach reject from the network, or since no SIM is present), initiate an ATTACH indicating that the ATTACH is for receiving emergency bearer services. After a successful attach, the services that the network provides the UE is solely in the context of Emergency Bearer Services.
- UEs that camp normally on a cell initiates a normal ATTACH if it requires emergency services. Normal attached UEs initiated a UE Requested PDN Connectivity procedure to request Emergency Bearer Services.

IMSI/IMEI Available in System Event Logs of Type Error and Critical

The SAEGW can be configured to provide the IMSI/IMEI in the event log details for the following system event logs of type error and critical, if available. If the IMSI is not available, the SAEGW will make a best effort to obtain the IMEI.

Use the **logging include-ueid** command in Global Configuration Mode to enable this functionality.

Table 7: New and Modified System Event Logs with IMSI/IMEI in System Event Log Details 20

Event Log #	Description
New Events	
12225	Represents misc_error3 in format "[IMSI <IMSI>] Misc Error3: %s, error code %d"
12226	Represents recover_call_from_crr_failed1 error in format "[IMSI <IMSI>]Sessmgr-%d Recover call from CRR failed for callid:0x%x reason=%s"
12227	Represents aaa_create_session_failed_no_more_sessions1 error in format "[IMSI <IMSI>] Sessmgr-%d Ran out of session handles"
140075	Represents error_log1 in format "[IMSI <IMSI>]%s"
Modified Events	
139001	To print miscellaneous PGW error log.
191006	To print miscellaneous SAEGW error log.
10034	Represents FSM error in format "[IMSI <IMSI>] default call fsm error: ostate=%s(%d) state=%s(%d) event=%s(%d)"
10035	Represents FSM INVALID event in format "[IMSI <IMSI>] default call fsm invalid event: state=%s(%d) event=%s(%d)"
12382	Represents SN_LE_SESSMGR_PGW_REJECT_BEARER_OP in format "[IMSI <IMSI>] Sessmgr-%d: Request to %s bearer rejected. Reason: %s". For example "[IMSI 112233445566778 Sessmgr-1: Request to Create bearer rejected. Reason: Create Bearer Request denied as session recovery is in progress"
12668	Represents fsm_event_error in format "[IMSI <IMSI>] Misc Error: Bad event in sessmgr fsm, event code %d"
12774	Represents pgw_purge_invalid_crr in format "[IMSI <IMSI>] Local %s TEID [%lu] Collision: Clp Connect Time: %lu, Old Clp Callid: %d, Old Clp Connect Time: %lu %s"
12855	Represents ncqos_nrspca_trig_err in format "[IMSI <IMSI>] NCQOS NRSPCA trig rcvd in invalid bcm mode."
12857	Represents ncqos_nrupc_tft_err in format "[IMSI <IMSI>] NCQOS NRUPC Trig : TFT validation failed for nsapi <%u>."
12858	Represents ncqos_nrxx_trig_already in format "[IMSI <IMSI>] NCQOS NRSPCA/NRUPC is already triggered on sess with nsapi <%u>."
12859	Represents ncqos_nrxx_tft_check_fail in format "[IMSI <IMSI>] NCQOS TFT check failed as TFT has invalid opcode for nsapi <%u>:pf_id_bitmap 0x%x and tft_opcode: %d"
12860	Represents ncqos_sec_rej in format "[IMSI <IMSI>] NCQOS Secondary ctxt with nsapi <%u> rejected, due to <%s>."

Event Log #	Description
12861	Represents ncqos_upc_rej in format "[IMSI <IMSI>] UPC Rejected for ctxt with nsapi <%u>, due to <%s>."
12862	Represents ggsn_subsession_invalid_state in format "[IMSI <IMSI>] GGSN subsession invalid state state:<%s>,[event:<%s>]"
11830	Represents gngp_handoff_rejected_for_pdn_ipv4v6 in format "[IMSI <IMSI>] Sessmgr-%d Handoff from PGW-to-GGSN rejected, as GGSN doesnt support Deferred allocation for IPv4v6, dropping the call."
11832	Represents gngp_handoff_rejected_no_non_gbr_bearer_for_def_bearer_selection in format "[IMSI <IMSI>] Sessmgr-%d Handoff from PGW-to-GGSN rejected, as GGSN Callline has no non-GBR bearer to be selected as Default bearer."
11834	Represents gngp_handoff_from_ggsn_rejected_no_ggsn_call in format "[IMSI <IMSI>] Sessmgr-%d Handoff from GGSN-to-PGW rejected, as GGSN call with TEIDC <0x%x> not found."
12960	Represents gtp_pdp_type_mismatch in format "[IMSI <IMSI>] Mismatch between PDP type of APN %s and in create req. Rejecting call"
11282	Represents pcc_intf_error_info in format "[IMSI <IMSI>] %s"
11293	Represents collision_error in format "[IMSI <IMSI>] Collision Error: Temp Failure Handling Delayed Pending Active Transaction: , error code %d"
11917	Represents rcvd_invalid_bearer_binding_req_from_acs in format "[IMSI <IMSI>] Sessmgr %d: Received invalid bearer binding request from ACS."
11978	Represents saegw_uid_error in format "[IMSI <IMSI>] %s"
11994	Represents unwanted_pcc_intf_setup_req error in format "[IMSI <IMSI>] GGSN_INITIATE_SESS_SETUP_REQ is already fwded to PCC interface "
140005	Represents ue_fsm_illegal_event in format "[IMSI <IMSI>] Invalid/unhandled UE event <%s> in state <%s>"
140006	Represents pdn_fsm_illegal_event in format "[IMSI <IMSI>] Invalid/unhandled PDN event <%s> in state <%s>"
140007	Represents epsb_fsm_illegal_event in format "[IMSI <IMSI>] Invalid/unhandled EPSB event <%s> in state <%s>"
10726	Represents saegwdrv_generic_error "[IMSI <IMSI>] %s"

IP Access Control Lists

IP access control lists allow you to set up rules that control the flow of packets into and out of the system based on a variety of IP packet parameters.

IP access lists, or access control lists (ACLs) as they are commonly referred to, are used to control the flow of packets into and out of the system. They are configured on a per-context basis and consist of "rules" (ACL

rules) or filters that control the action taken on packets that match the filter criteria. Once configured, an ACL can be applied to any of the following:

- An individual interface
- All traffic facilitated by a context (known as a policy ACL)
- An individual subscriber
- All subscriber sessions facilitated by a specific context



Important

For more information on IP access control lists, refer to the *IP Access Control Lists* chapter in the *System Administration Guide*.

IP Address Hold Timers

Also known as address quarantining, this subscriber-level CLI introduces an address hold timer to temporarily buffer a previously assigned IP address from an IP address pool to prevent it from being recycled and reassigned to a new subscriber session. It is especially useful during inter-RAT handovers that sometimes lead to temporary loss of the mobile data session.

This feature provides a higher quality user experience for location-based services where the remote host server needs to reach the mobile device.



Important

Currently, the P-GW only supports an address hold timer with IPv4 addresses.

IPv6 Capabilities

Enables increased address efficiency and relieves pressures caused by rapidly approaching IPv4 address exhaustion problem.

The P-GW offers the following IPv6 capabilities:

Native IPv6 and IPv6 transport

- Support for any combination of IPv4, IPv6 or dual stack IPv4/v6 address assignment from dynamic or static address pools on the P-GW.
- Support for native IPv6 transport and service addresses on PMIPv6 S2a interface. Note that transport on GTP S5/S8 connections in this release is IPv4 based.
- Support for IPv6 transport for outbound traffic over the SGi reference interface to external Packet Data Networks.

IPv6 Connections to Attached Elements

IPv6 transport and interfaces are supported on all of the following connections:

- Diameter Gx policy signaling interface
- Diameter Gy online charging reference interface

- S6b authentication interface to external 3GPP AAA server
- Diameter Rf offline charging interface
- Lawful Intercept (X1, X2 interfaces)

Routing and Miscellaneous Features

- OSPFv3
- MP-BGP v6 extensions
- IPv6 flows (Supported on all Diameter QoS and Charging interfaces as well as Inline Services (e.g. ECS))

IPv6 MTU Option Support in RA Message

In RFC-4861, there is a provision to send the Maximum Transmission Unit (MTU) in Router Advertisement (RA) messages. The P-GW now supports the sending of the IPv6 MTU option in RAs for IPv6 and IPv4v6 PDN types towards the UE. As a result, the UE can now send uplink data packets based on the configured MTU and perform data fragmentation at the source, if required. This feature also reduces the number of ICMPv6 *Packet Too Big Error* messages in the customer's network.

The MTU size is configurable via the Command Line Interface (CLI) on the GGSN and P-GW.

Supported Functionality

To support the IPv6 MTU Option in RA Message feature, the P-GW/GGSN supports the following functionality and behavior:

- The **ipv6 initial-router-advt option mtu value** command in *APN Configuration Mode* is available to enable/disable this feature per APN. By default, this feature is enabled for all APNs.
 - For the P-GW and SAEGW, IPv6 initial router advertisement option MTU value must be configured in *octets -integer 1280-2000*. The configured value is sent in the RA packet rather than the data tunnel MTU.



Important

This value is used only for advertisement in RA packet and the gateway need not enforce this value. The behaviour of 'default' and 'no' options of this CLI remains the same.

- For the P-GW and SAEGW, the session manager sends the MTU value that is configured via the CLI command **data-tunnel mtu 1280-2000** in *APN Configuration Mode*.
- For the GGSN, the RADIUS-returned value in the Framed-MTU Attribute Value Pair (AVP) takes precedence over the value configured via the **ppp mtu 100-2000** CLI command in *APN Configuration Mode*.
- For the GGSN, if the RADIUS-returned MTU value is less than the minimum IPv6 MTU, then the minimum IPv6 MTU value of 1280 is sent in the IPv6 MTU option field in RA messages.
- For the GGSN, if the **ppp mtu 100-2000** CLI command is configured with an MTU value of less than 1280, then the minimum IPv6 MTU value is sent in the IPv6 MTU option field in RA messages.

- When no MTU value comes from the RADIUS server and both the above mentioned CLI commands are not configured, the default value of 1500 is used for the MTU.
- Support for the MTU option in RA messages is available in the GGSN/P-GW/SAEGW.
- This feature is supported on the P-GW independent of interfaces such as s2a/s2b/s5/s8.
- The MTU option in RA messages is supported for both IPv6 and IPv4v6 PDN types.
- The MTU option in RA messages is available in the output of the **monitor protocol** command.
- The same MTU value is sent by the gateway in initial and periodic RA messages for a calling.
- The behavior of sending the IPv6 MTU option in RA for a PDN call is persistent across session recovery and ICSR switchover.
- Existing MTU-related data path behavior for the GGSN/P-GW/SAEGW is not changed.

Restrictions/Limitations

Note the following restrictions/limitations for this feature:

- The GGSN/P-GW/SAEGW does not consider the GTP-U tunnel overhead while calculating the MTU value to be sent in the IPv6 MTU option in RAs. Therefore, the operator has to configure the **data-tunnel mtu** by considering the tunnel overhead. Refer to the *Link MTU Considerations* section in *Annex-C of 3GPP TS 23.060*.
- Existing MTU-related data path behavior for the GGSN/P-GW/SAEGW is unchanged.
- If there is a Gn/Gp Handover followed by session recovery, operators will see the following behavior: The stateless IPv6 session is recovered with the MTU value configured for the current GGSN/P-GW service after the handover. This is existing behavior if the feature is not configured. With this feature enabled, the same recovered MTU value will be sent in periodic RA messages after such a handover occurs when followed by session recovery.
- This feature is not supported for eHRPD. As a result, in scenarios where an LTE-to-eHRPD to LTE-Handover or eHRPD-to-LTE Handover occurs, a new stateless IPv6 session is re-created using the latest APN configuration.
- With this feature enabled, there is no support for an MTU value received by the gateway via the S6b interface.

IPv6 Prefix-Based Search Support for LTE-WiFi Handoff

LTE-to-WiFi handoffs were failing for some UE devices for a specific customer during Inter-RAT testing for WiFi. The UE devices were using Stateless Address Auto Configuration. This issue was only seen from specific UE devices when the UE is sending the changed IPv6 address on Create Session Response (CSResp) messages during handoffs. Another vendor device had no issues for the LTE-to-WiFi handoff since it was sending the IPv6 address assigned initially during the Create Session Response (CSResp) from P-GW.

When the P-GW performed an IPv6 lookup of the existing LTE session based on the complete IPv6 128-bit address (Prefix + Intf ID), the handover would fail with the error EGTP_CONTEXT_NOT_FOUND.

Now, the P-GW performs the IPv6 lookup of the existing LTE session during an LTE-WiFi handoff using only the IPv6 prefix (64-bit). Operators now will see seamless handovers on these calls for UE devices with

Stateless Address Auto Configuration. The P-GW will not reject the handoff request if the UE uses a different interface-ID from the one provided during call creation during handoffs for PDN types IPv6 and IPv4v6.



Important There are no changes on external interfaces. The only change as part of this feature is that the internal search to find the existing session is performed using the 64-bit IPv6 prefix during handoff.

Restrictions/Limitations

With Stateless Auto Configuration, when the UE uses a different interface-ID from the one provided by P-GW. The UE then later moves to another location that results in an S1/X2 handover with an S-GW change. As result, the S-GW may have a different IPv6 address for a PDN from the one maintained by the P-GW (that is, the IP Address provided during initial attach) for the same UE. This can result in a difference in the servedPDPPDNAddress element in the CDR from the P-GW and S-GW.

This restriction is due to an existing limitation in the 3GPP Modify procedure, such as Modify Bearer Request/Modify Bearer Response, where an exchange of the changed UE IPv6 address is not supported between the P-GW and S-GW during the S1/X2 handover.

It is assumed that the mediation devices will look into the 64-bit prefix of the IPv6 address in CDRs for Stateless Auto Configuration devices.

Local Break-Out

Provides a standards-based procedure to enable LTE operators to generate additional revenues by accepting traffic from visited subscribers based on roaming agreements with other mobile operators.

Local Breakout is a policy-based forwarding function that plays an important role in inter-provider roaming between LTE service provider networks. Local Breakout is determined by the SLAs for handling roaming calls between visited and home networks. In some cases, it is more beneficial to locally breakout a roaming call on a foreign network to the visited P-W rather than incur the additional transport costs to backhaul the traffic to the Home network.

If two mobile operators have a roaming agreement in place, Local Break-Out enables the visited user to attach to the V-PLMN network and be anchored by the local P-GW in the visited network. The roaming architecture relies on the HSS in the home network and also introduces the concept of the S9 policy signaling interface between the H-PCRF in the H-PLMN and the V-PCRF in the V-PLMN. When the user attaches to the EUTRAN cell and MME (Mobility Management Entity) in the visited network, the requested APN name in the S6a NAS signaling is used by the HSS in the H-PLMN to select the local S-GW (Serving Gateway) and P-GWs in the visited EPC network.

Mapping High Throughput Sessions on Session Managers

Session managers are upgraded to manage several high throughput sessions without sharing the core and without creating a bottleneck on the CPU load.

The gateway – S-GW, SAEGW or P-GW, classifies a session as a high throughput session based on a DCNR flag present in the IE: FLAGS FOR USER PLANE FUNCTION (UPF) SELECTION INDICATION, in the Create Session Request. This DCNR flag is checkpointed and recovered by the gateway.

A high throughput session is placed on a session manager that has no other high throughput session. If all session manager are handling a high throughput session then these sessions are allocated using the Round-Robbin method.

**Note**

- The selection of session managers for non-high throughput sessions remains the same in the existing setup.
- Non-high throughput sessions are placed along with the high throughput sessions on the same session manager.

Limitations

Managing high throughput sessions on a session manager has the following limitations:

- The following scenarios may result in placing two high throughput sessions on a session manager:
 - Initial attach from eHRPD/2G/3G sessions.
 - IP addresses – both IPv4 and IPv6, are placed on the same session manager.
 - For an S-GW, the second Create Session Request (PDN) from a UE lands directly on a session manager which has the first PDN of the same UE.
 - For a collapsed call, the second Create Session Request (PDN) from a UE lands directly on a session manager which has the first PDN of the same UE.
 - In a Multi-PDN call from a UE that is capable of DCNR. For example: VoLTE and Internet capable of DCN will be placed on the same session manager.
- The DCNR flag is not defined by 3GPP for Wi-Fi. Therefore, a session cannot be assigned to a session manager during a Wi-Fi to LTE handover with the DCNR flag set.
- This feature manages and supports distribution of high throughput sessions on a session manager but does not guarantee high throughput for a subscriber.
- In some cases, the round robin mechanism could place a high throughput session on a session manager that was already loaded with other high throughput sessions.

MPLS EXP Marking of User Plane Traffic

Similar to 802.1p marking, MPLS EXP bit marking is supported for Enterprise APNs that use MPLS tunneling on the SGi interface on the P-GW. The QoS marking used in the LTE/EPC network (QCI per EPS bearer) is mapped to the 802.1p and MPLS EXP bit marking between the P-GW and L2/EPC switch and MPLS/PE routers (this is applicable to the upstream direction, from the P-GW to the Network). MPLS EXP marking related configuration is available as part of the QCI-QOS configuration table. MPLS EXP marking is selected based on QCI of the bearer to which that packet belongs.

**Important**

The SAEGW does not support non-standard QCI values. QCI values 1 through 9 are standard values and are defined in 3GPP TS 23.203; the SAEGW supports these standard values.

Mobile IP Registration Revocation

Mobile IP registration revocation functionality provides the following benefits:

- Timely release of Mobile IP resources at the HSGW and/or P-GW
- Accurate accounting
- Timely notification to mobile node of change in service

Registration Revocation is a general mechanism whereby either the P-GW or the HSGW providing Mobile IP functionality to the same mobile node can notify the other mobility agent of the termination of a binding. Mobile IP Registration Revocation can be triggered at the HSGW by any of the following:

- Session terminated with mobile node for whatever reason
- Session renegotiation
- Administrative clearing of calls
- Session Manager software task outage resulting in the loss of HSGW sessions (sessions that could not be recovered)



Important

Registration Revocation functionality is also supported for Proxy Mobile IP. However, only the P-GW can initiate the revocation for Proxy-MIP calls.



Important

For more information on MIP registration revocation support, refer to the *Mobile IP Registration Revocation* chapter in this guide.

MTU Size PCO

UEs usually use a hardcoded MTU size for IP communication. If this hardcoded value is not in sync with the network supported value, it can lead to unnecessary fragmentation of packets sent by the UE. Thus, in order to avoid unnecessary fragmentation, this feature helps in using the network-provided MTU size instead of the hardcoded MTU in UE.

3GPP defined a new PCO option in Release 10 specifications for the network to be able to provide an IPv4 MTU size to the UE. P-GW supports an option to configure a IPv4 Link MTU size in the APN profile.

If the UE requests IPv4 Link MTU size in the PCO options during Initial Attach or PDN connectivity request, the P-GW will provide the preconfigured value based on the APN.

If the MTU size configuration on APN is changed, the new MTU size will take effect only for new PDN connections and initial attaches. P-GW will not update for the existing PDN connections.

If the UE does not request IPv4 Link MTU size, P-GW will not include the IPv4 Link MTU size.

Multiple PDN Support

Enables an APN-based user experience that enables separate connections to be allocated for different services including IMS, Internet, walled garden services, or off-deck content services.

The MAG function on the S-GW can maintain multiple PDN or APN connections for the same user session. The MAG runs a single node level Proxy Mobile IPv6 tunnel for all user sessions toward the LMA function of the P-GW. When a user wants to establish multiple PDN connections, the MAG brings up the multiple PDN connections over the same PMIPv6 session to one or more P-GW LMA's. The P-GW in turn allocates separate IP addresses (Home Network Prefixes) for each PDN connection and each one can run one or multiple EPC default & dedicated bearers. To request the various PDN connections, the MAG includes a common MN-ID and separate Home Network Prefixes, APNs and a Handover Indication Value equal to one in the PMIPv6 Binding Updates.



Important Up to 11 multiple PDN connections are supported.

Node Functionality GTP Echo

This feature helps exchange capabilities of two communicating GTP nodes, and uses the new feature based on whether it is supported by the other node.

This feature allows S-GW to exchange its capabilities (MABR, PRN, NTSR) with the peer entities through ECHO messages. By this, if both the peer nodes support some common features, then they can make use of new messages to communicate with each other.

With new "node features" IE support in ECHO request/response message, each node can send its supported features (MABR, PRN, NTSR). This way, S-GW can learn the peer node's supported features. S-GW's supported features can be configured by having some configuration at the service level.

If the S-GW wants to use new message, such as P-GW Restart Notification, then the S-GW should check if the peer node supports this new feature or not. If the peer does not support it, then the S-GW should fall back to old behavior.

If the S-GW receives a new message from the peer node, and if S-GW does not support this new message, then the S-GW should ignore it. If the S-GW supports the particular feature, then it should handle the new message as per the specification.

Non-Optimized e-HRPD to Native LTE (E-UTRAN) Mobility Handover

This feature enables a seamless inter-technology roaming capability in support of dual mode e-HRPD/e-UTRAN access terminals.

The non-optimized inter-technology mobility procedure is rooted at the P-GW as the mobility anchor point for supporting handovers for dual radio technology e-HRPD/E-UTRAN access terminals. To support this type of call handover, the P-GW supports handoffs between the GTP-based S5/S8 (GTPv2-C / GTPv1-U) and PMIPv6 S2a tunneled connections. It also provisions IPv4, IPv6, or dual stack IPv4/IPv6 PDN connections from a common address pool and preserves IP addresses assigned to the UE during inter-technology handover. In the current release, the native LTE (GTP-based) P-GW service address is IPv4-based, while the e-HRPD (PMIP) address is an IPv6 service address.

During the initial network attachment for each APN that the UE connects to, the HSS returns the FQDN of the P-GW for the APN. The MME uses DNS to resolve the P-GW address. When the PDN connection is established in the P-GW, the P-GW updates the HSS with the IP address of the P-GW on PDN establishment through the S6b authentication process. When the mobile user roams to the e-HRPD network, the HSS returns the IP address of the P-GW in the P-GW Identifier through the STa interface and the call ends up in the same P-GW. The P-GW is also responsible for initiating the session termination on the serving access connection after the call handover to the target network.

During the handover procedure, all dedicated EPS bearers must be re-established. On LTE- handovers to a target e-HRPD access network, the dedicated bearers are initiated by the mobile access terminal. In contrast, on handovers in the opposite direction from e-HRPD to LTE access networks, the dedicated bearers are network initiated through Gx policy interactions with the PCRF server.

Finally, in order to support the inter-technology handovers, the P-GW uses common interfaces and Diameter endpoint addresses for the various reference points:

- S6b: Non-3GPP authentication
- Gx: QoS Policy and Charging
- Rf: Offline Charging

All three types of sessions are maintained during call handovers. The bearer binding will be performed by the HSGW during e-HRPD access and by the P-GW during LTE access. Thus, the Bearer Binding Event Reporting (BBERF) function needs to migrate between the P-GW and the HSGW during the handover. The HSGW establishes a Gxa session during e-HRPD access for bearer binding and releases the session during LTE access. The HSGW also maintains a limited context during the e-HRPD <->LTE handover to reduce latency in the event of a quick handover from the LTE RAN back to the e-HRPD network.



Important For more information on handoff interfaces, refer to the *Supported Logical Network Interfaces (Reference Points)* section in this chapter.

Online/Offline Charging

The Cisco EPC platform offers support for online and offline charging interactions with external OCS and CGF/CDF servers.

Online Charging

Gy/Ro Reference Interfaces

The StarOS 9.0 online prepaid reference interface provides compatibility with the 3GPP TS 23.203, TS 32.240, TS 32.251 and TS 32.299 specifications. The Gy/Ro reference interface uses Diameter transport and IPv6 addressing. Online charging is a process whereby charging information for network resource usage must be obtained by the network in order for resource usage to occur. This authorization is granted by the Online Charging System (OCS) upon request from the network. The P-GW uses a charging characteristics profile to determine whether to activate or deactivate online charging. Establishment, modification or termination of EPS bearers is generally used as the event trigger on the PCRF to activate online charging PCC rules on the P-GW.

When receiving a network resource usage request, the network assembles the relevant charging information and generates a charging event towards the OCS in real-time. The OCS then returns an appropriate resource

usage authorization that may be limited in its scope (e.g. volume of data or duration based). The OCS assigns quotas for rating groups and instructs the P-GW whether to continue or terminate service data flows or IP CAN bearers.

The following Online Charging models and functions are supported:

- Time based charging
- Volume based charging
- Volume and time based charging
- Final Unit Indication and termination or redirection of service data flows when quota is consumed
- Reauthorization triggers to rearm quotas for one or more rating groups using multi-service credit control (MSCC) instances
- Event based charging
- Billing cycle bandwidth rate limiting: Charging policy is enforced through interactions between the PDN GW and Online Charging Server. The charging enforcement point periodically conveys accounting information for subscriber sessions to the OCS and it is debited against the threshold that is established for the charging policy. Subscribers can be assigned a max usage for their tier (gold, silver, bronze for example), the usage can be tracked over a month, week, day, or peak time within a day. When the subscriber exceeds the usage limit, bandwidth is either restricted for a specific time period, or dropped depending on their tier of service.
- Fair usage controls

Offline Charging

Ga/Gz Reference Interfaces

The Cisco P-GW supports 3GPP-compliant offline charging as defined in TS 32.251, TS 32.297 and 32.298. Whereas the S-GW generates SGW-CDRs to record subscriber level access to PLMN resources, the P-GW creates PGW-CDRs to record user access to external networks. Additionally, when Gn/Gp interworking with pre-release SGSNs is enabled, the GGSN service on the P-GW records G-CDRs to record user access to external networks.

To provide subscriber level accounting, the Cisco S-GW and P-GWs support integrated Charging Transfer Functions (CTF) and Charging Data Functions (CDF). Each gateway uses Charging-ID's to distinguish between default and dedicated bearers within subscriber sessions. The Ga/Gz reference interface between the CDF and CGF is used to transfer charging records via the GTPP protocol. In a standards based implementation, the CGF consolidates the charging records and transfers them via an FTP/S-FTP connection over the Bm reference interface to a back-end billing mediation server. The Cisco EPC gateways also offer the ability to FTP/S-FTP charging records between the CDF and CGF server. CDR records include information such as Record Type, Served IMSI, ChargingID, APN Name, TimeStamp, Call Duration, Served MSISDN, PLMN-ID, etc. The ASR 5x00 platform offers a local directory to enable temporary file storage and buffer charging records in persistent memory located on a pair of dual redundant RAID hard disks. Each drive includes 147GB of storage and up to 100GB of capacity is dedicated to storing charging records. For increased efficiency it is also possible to enable file compression using protocols such as GZIP. The Offline Charging implementation offers built-in heart beat monitoring of adjacent CGFs. If the Cisco P-GW has not heard from the neighbor CGF within the configurable polling interval, they will automatically buffer the charging records on the local drives until the CGF reactivates itself and is able to begin pulling the cached charging records.

The P-GW supports a Policy Charging Enforcement Function (PCEF) to enable Flow Based Bearer Charging (FBC) via the Gy reference interface to adjunct OCS servers (See Online Charging description above).

Rf Reference Interface

The Cisco EPC platforms also support the Rf reference interface to enable direct transfer of charging files from the CTF function of the P-GW to external CDF/CGF servers. This interface uses Diameter Accounting Requests (Start, Stop, Interim, and Event) to transfer charging records to the CDF/CGF. Each gateway relies on triggering conditions for reporting chargeable events to the CDF/CGF. Typically as EPS bearers are activated, modified or deleted, charging records are generated. The EPC platforms include information such as Subscription-ID (IMSI), Charging-ID (EPS bearer identifier) and separate volume counts for the uplink and downlink traffic.

Optimization for egtpinmgr Recovery

Restarting the egtpinmgr task took a significant amount of time for recovery. Hence, the outage time when the GGSN, P-GW, SAEGW, and S-GW were unable to accept any new calls during egtpinmgr recovery was high.

The software is enhanced to optimize the recovery outage window in the event of an egtpinmgr task restart; this has been achieved by optimizing the internal algorithms of egtpinmgr recovery and the data structures required. In addition, recovery time now is dependent only on the number of unique IMSIs and not on the number of sessions for an IMSI.

P-CSCF Recovery

Supports spec-based mechanism to support P-CSCF discovery for GTP-based S2b interface for WiFi integration. This is required for Voice over WiFi service.

The P-GW can store the P-CSCF FQDN received during the initial registration with the AAA. Upon receiving the P-CSCF restoration flag from the MME/S-GW, the P-GW performs a new DNS query using the existing P-CSCF FQDN to provide the updated list of three P-CSCF IP addresses using PCO.

Peer GTP Node Profile Configuration Support

Provides flexibility to the operators to have different configuration for GTP-C and Lawful Intercept, based on the type of peer or the IP address of the peer.

Peer profile feature allows flexible profile based configuration to accommodate growing requirements of customizable parameters with default values and actions for peer nodes of P-GW. With this feature, configuration of GTP-C parameters and disabling/enabling of Lawful Intercept per MCC/MNC or IP address based on rules defined.

A new framework of peer-profile and peer-map is introduced. Peer-profile configuration captures the GTP-C specific configuration and/or Lawful Intercept enable/disable configuration. GTP-C configuration covers GTP-C retransmission (maximum number of retries and retransmission timeout) and GTP echo configuration. Peer-map configuration matches the peer-profile to be applied to a particular criteria. Peer-map supports criteria like MCC/MNC (PLMN-ID) of the peer or IP-address of the peer. Peer-map can then be associated with P-GW service.

Intent of this feature is to provide flexibility to operators to configure a profile which can be applied to a specific set of peers. For example, have a different retransmission timeout for foreign peers as compared to home peers.

Per QCI Packet Drop Counters and ARP Granularity for QCI Level Counters

Support for QCI and ARP Visibility

As of StarOS release 20.2, the software has been enhanced to support the viewing of QoS statistics on a Quality of Service Class Index (QCI) and Allocation and Retention Priority (ARP) basis.

ARP is a 3GPP mechanism for dropping or downgrading lower-priority bearers in situations where the network becomes congested. The network looks at the ARP when determining if new dedicated bearers can be established through the radio base station. QCI is an operator provisioned value that controls bearer level packet forwarding treatments.

This enhancement enables operators to monitor QoS statistics that identify multiple services running with the same QCI value. In addition, packet drop counters have been introduced to provide the specific reason the Enhanced Charging Service (ECS) dropped a packet. The packet drop counters provide output on a per ARP basis. This provides additional information that operators can use to troubleshoot and identify network issues that may be affecting service.



Important For the ARP value only the priority level value in the Allocation/Retention Priority (ARP) Information Element (IE) is considered. Pre-emption Vulnerability (PVI) and Pre-emption Capability (PCI) flags in the ARP IE are not considered.

The existing **show apn statistics name** *apn-name* and **show apn statistics Exec Mode** CLI commands have been enhanced. The output of these commands now provides visibility for QoS statistics on a QCI/ARP basis.



Important For more detailed information, refer to the *Extended QCI Options* chapter in this guide.

Licensing

ARP Granularity for QCI Level Counters is a license-controlled feature. Per QCI Packet Drop Counters functionality does not require a license. Contact your Cisco account or support representative for licensing details.

PMIPv6 Heartbeat

Proxy Mobile IPv6 (PMIPv6) is a network-based mobility management protocol to provide mobility without requiring the participation of the mobile node in any PMIPv6 mobility related signaling. The core functional entities Mobile Access Gateway (MAG) and the Local Mobility Anchor (LMA) set up tunnels dynamically to manage mobility for a mobile node.

Path management mechanism through Heartbeat messages between the MAG and LMA is important to know the reachability of the peers, to detect failures, quickly inform peers in the event of a recovery from node failures, and allow a peer to take appropriate action.

PMIP heartbeats from the HSGW to the P-GW are supported per RFC 5847. Refer to the **heartbeat** command in the LMA Service mode or MAG Service mode respectively to enable this heartbeat and configure the heartbeat variables.

Proxy Mobile IPv6 (S2a)

Provides a mobility management protocol to enable a single LTE-EPC core network to provide the call anchor point for user sessions as the subscriber roams between native EUTRAN and non-native e-HRPD access networks

S2a represents the trusted non-3GPP interface between the LTE-EPC core network and the evolved HRPD network anchored on the HSGW. In the e-HRPD network, network-based mobility provides mobility for IPv6 nodes without host involvement. Proxy Mobile IPv6 extends Mobile IPv6 signaling messages and reuses the HA function (now known as LMA) on the P-GW. This approach does not require the mobile node to be involved in the exchange of signaling messages between itself and the Home Agent. A proxy mobility agent (e.g. MAG function on HSGW) in the network performs the signaling with the home agent and does the mobility management on behalf of the mobile node attached to the network.

The S2a interface uses IPv6 for both control and data. During the PDN connection establishment procedures the P-GW allocates the IPv6 Home Network Prefix (HNP) via Proxy Mobile IPv6 signaling to the HSGW. The HSGW returns the HNP in router advertisement or based on a router solicitation request from the UE. PDN connection release events can be triggered by either the UE, the HSGW or the P-GW.

In Proxy Mobile IPv6 applications the HSGW (MAG function) and P-GW (LMA function) maintain a single shared tunnel and separate GRE keys are allocated in the PMIP Binding Update and Acknowledgment messages to distinguish between individual subscriber sessions. If the Proxy Mobile IP signaling contains Protocol Configuration Options (PCOs) it can also be used to transfer P-CSCF or DNS server addresses.

QoS Bearer Management

Provides a foundation for contributing towards improved Quality of User Experience (QoE) by enabling deterministic end-to-end forwarding and scheduling treatments for different services or classes of applications pursuant to their requirements for committed bandwidth resources, jitter and delay. In this way, each application receives the service treatment that users expect.

An EPS bearer is a logical aggregate of one or more Service Data Flows (SDFs), running between a UE and a P-GW in case of GTP-based S5/S8, and between a UE and HSGW in case of PMIP-based S2a connection. An EPS bearer is the level of granularity for bearer level QoS control in the EPC/E-UTRAN. The Cisco P-GW maintains one or more Traffic Flow Templates (TFT's) in the downlink direction for mapping inbound Service Data Flows (SDFs) to EPS bearers. The P-GW maps the traffic based on the downlink TFT to the S5/S8 bearer. The Cisco PDN GW offers all of the following bearer-level aggregate constructs:

QoS Class Identifier (QCI): An operator provisioned value that controls bearer level packet forwarding treatments (e.g. scheduling weights, admission thresholds, queue management thresholds, link layer protocol configuration, etc). The Cisco EPC gateways also support the ability to map the QCI values to DiffServ code points in the outer GTP tunnel header of the S5/S8 connection. Additionally, the platform also provides configurable parameters to copy the DSCP marking from the encapsulated payload to the outer GTP tunnel header.



Important The SAEGW does not support non-standard QCI values. QCI values 1 through 9 are standard values and are defined in 3GPP TS 23.203; the SAEGW supports these standard values.

Guaranteed Bit Rate (GBR): A GBR bearer is associated with a dedicated EPS bearer and provides a guaranteed minimum transmission rate in order to offer constant bit rate services for applications such as interactive voice that require deterministic low delay service treatment.

Maximum Bit Rate (MBR): The MBR attribute provides a configurable burst rate that limits the bit rate that can be expected to be provided by a GBR bearer (e.g. excess traffic may get discarded by a rate shaping function). The MBR may be greater than or equal to the GBR for a given Dedicated EPS bearer.

Aggregate Maximum Bit Rate (AMBR): AMBR denotes a bit rate of traffic for a group of bearers destined for a particular PDN. The Aggregate Maximum Bit Rate is typically assigned to a group of Best Effort service data flows over the Default EPS bearer. That is, each of those EPS bearers could potentially utilize the entire AMBR, e.g. when the other EPS bearers do not carry any traffic. The AMBR limits the aggregate bit rate that can be expected to be provided by the EPS bearers sharing the AMBR (e.g. excess traffic may get discarded by a rate shaping function). AMBR applies to all Non-GBR bearers belonging to the same PDN connection. GBR bearers are outside the scope of AMBR.

Policing: The Cisco P-GW offers a variety of traffic conditioning and bandwidth management capabilities. These tools enable usage controls to be applied on a per-subscriber, per-EPS bearer or per-PDN/APN basis. It is also possible to apply bandwidth controls on a per-APN AMBR capacity. These applications provide the ability to inspect and maintain state for user sessions or Service Data Flows (SDFs) within them using shallow L3/L4 analysis or high touch deep packet inspection at L7. Metering of out-of-profile flows or sessions can result in packet discards or reducing the DSCP marking to Best Effort priority.

RADIUS Support

Provides a mechanism for performing authorization, authentication, and accounting (AAA) for subscriber PDP contexts based on the following standards:

- RFC-2618, RADIUS Authentication Client MIB, June 1999
- RFC-2620, RADIUS Accounting Client MIB, June 1999
- RFC-2865, Remote Authentication Dial In User Service (RADIUS), June 2000
- RFC-2866, RADIUS Accounting, June 2000
- RFC-2867, RADIUS Accounting Modifications for Tunnel Protocol Support, June 2000
- RFC-2868, RADIUS Attributes for Tunnel Protocol Support, June 2000
- RFC-2869, RADIUS Extensions, June 2000

The Remote Authentication Dial-In User Service (RADIUS) protocol is used to provide AAA functionality for subscriber PDP contexts. (RADIUS accounting is optional since GTPP can also be used.)

Within contexts configured on the system, there are AAA and RADIUS protocol-specific parameters that can be configured. The RADIUS protocol-specific parameters are further differentiated between RADIUS Authentication server RADIUS Accounting server interaction.

Among the RADIUS parameters that can be configured are:

- **Priority:** Dictates the order in which the servers are used allowing for multiple servers to be configured in a single context.
- **Routing Algorithm:** Dictate the method for selecting among configured servers. The specified algorithm dictates how the system distributes AAA messages across the configured AAA servers for new sessions. Once a session is established and an AAA server has been selected, all subsequent AAA messages for the session will be delivered to the same server.

In the event that a single server becomes unreachable, the system attempts to communicate with the other servers that are configured. The system also provides configurable parameters that specify how it should behave should all of the RADIUS AAA servers become unreachable.

The system provides an additional level of flexibility by supporting the configuration RADIUS server groups. This functionality allows operators to differentiate AAA services for subscribers based on the APN used to facilitate their PDP context.

In general, 128 AAA Server IP address/port per context can be configured on the system and it selects servers from this list depending on the server selection algorithm (round robin, first server). Instead of having a single list of servers per context, this feature provides the ability to configure multiple server groups. Each server group, in turn, consists of a list of servers.

This feature works in following way:

- All RADIUS authentication/accounting servers configured at the context-level are treated as part of a server group named "default". This default server group is available to all subscribers in that context through the realm (domain) without any configuration.
- It provides a facility to create "user defined" RADIUS server groups, as many as 399 (excluding "default" server group), within a context. Any of the user defined RADIUS server groups are available for assignment to a subscriber through the APN configuration within that context.

Since the configuration of the APN can specify the RADIUS server group to use as well as IP address pools from which to assign addresses, the system implements a mechanism to support some in-band RADIUS server implementations (i.e. RADIUS servers which are located in the corporate network, and not in the operator's network) where the NAS-IP address is part of the subscriber pool. In these scenarios, the P-GW supports the configuration of the first IP address of the subscriber pool for use as the RADIUS NAS-IP address.



Important For more information on RADIUS AAA configuration, if you are using StarOS 12.3 or an earlier release, refer to the *AAA and GTPP Interface Administration and Reference*. If you are using StarOS 14.0 or a later release, refer to the *AAA Interface Administration and Reference*.

Removal of Private Extension-based Overcharging Support

Prior to StarOS release 21.0, the Cisco P-GW and S-GW supported the sending and receiving of overcharging protection data via both a non-3GPP Private Extension Information Element (IE), and a 3GPP Indication IE.

However, since 3GPP support to exchange overcharging protection data exists, no operators were using the Overcharging Private Extension (OCP) based solution. It was also reported by some operators that the Private Extension IE carrying overcharging protection data sent by the P-GW was leading to issues at S-GWs of other vendors.

As a result, support for Private Extension-based Overcharging Support is being removed from the Cisco P-GW and S-GW. This has the benefit of preventing unexpected scenarios occurring due to the decoding of a Private Extension ID carrying overcharging protection data at the P-GW/S-GW of other vendors.

Previous and New Behavior for the P-GW

The following table describes the previous and new behavior at the P-GW for Create Session Request (CSReq) and Create Session Response (CSRsp) messages due to the removal of Private Extension Overcharging Support.

Table 8: Previous and New Behavior: CSReq and CSRsp Messages at P-GW Due to Removal of Private Extension Overcharging Support

Scenario No.	IE Carrying OCP Capability Received from S-GW in CSReq	Old Behavior: IE carrying OCP Capability Sent to S-GW in CSRsp	New Behavior: IE Carrying OCP Capability Sent to S-GW in CSRsp
1	Indication IE	Indication IE	No change. Indication IE will be sent in CSRsp.
2	Private Extension IE	Both Private Extension and Indication IEs.	Private Extension IE received from S-GW is ignored. Indication IE is sent in CSRsp.
3	None	Both Private Extension and Indication IEs.	Only Indication IE is sent in CSRsp.
4	Both Private Extension and Indication IEs.	Indication IE	Private Extension IE received from S-GW is ignored. Only Indication IE is sent in CSRsp.

The following table describes the previous and new behavior in Modify Bearer Request (MBReq) and Modify Bearer Response (MBRsp) messages due to the removal of Private Extension Overcharging Support.

Table 9: Previous and New Behavior: MBRreq and MBRsp Messages at P-GW Due to Removal of Private Extension Overcharging Support

Scenario No.	IE carrying OCP Capability Received from S-GW in MBReq	Old Behavior: IE Carrying OCP Capability Sent to S-GW in MBRsp	New Behavior: IE Carrying OCP Capability Sent to S-GW in MBRsp
1	Indication IE	Indication IE	No Change. Indication IE is sent in MBRsp messages.
2	Private Extension IE	Private Extension IE	Private Extension IE received from S-GW is ignored. Indication IE is sent in MBRsp message.
3	None	Both Private Extension and Indication IEs.	Only the Indication IE is sent in MBRsp message.
4	Both Private Extension and Indication IEs.	Indication IE	Private Extension IE received from the S-GW is ignored. Only the Indication IE is sent in the MBRsp message.

Previous and New Behavior for the S-GW

The following table describes the previous and new behavior in Create Session Response (CSRsp) messages at the S-GW due to the removal of Private Extension Overcharging Support.

Table 10: Previous and New Behavior: CSRsp Messages at the S-GW Due to the Removal of Private Extension Overcharging Support

Scenario No.	Old Behavior: IE Carrying OCP Capability Received from P-GW in CSRsp	New Behavior: IE Carrying OCP Capability Received from PGW in CSRsp	Old Behavior: IE Carrying OCP Capability Sent to MME in CSRsp	New Behavior: IE Carrying OCP Capability Sent to MME in CSRsp
12	Indication IE	No change. OCP capability received as part of the Indication IE is accepted.	Indication IE	No change. Indication IE is sent in CSRsp.
2	Private Extension IE	OCP capability received as part of Private Extension IE is ignored.	If gtpc private-extension overcharge-protection is disabled at egtpc service level: Private Extension IE . If gtpc private-extension overcharge-protection is enabled at egtpc service level: Indication IE .	Since the CLI command is deprecated, then the Private Extension IE is forwarded to the MME in CSRsp as would be done for any unknown Private Extension IE.
3	Both Private Extension IE and Indication IE	OCP capability received as part of the Private Extension IE is ignored. Only OCP capability received as a part of the Indication IE is accepted.	If gtpc private-extension overcharge-protection is disabled at egtpc service level: Private Extension IE and Indication IE . If gtpc private-extension overcharge-protection is enabled at egtpc service level: Indication IE .	Since the CLI command is deprecated, then the Private Extension IE is forwarded to the MME in CSRsp as would be done for any unknown Private Extension IE.
4	None	No change.	None	No change.

The following table describes the previous and new behavior in Modify Bearer Response (MBRsp) messages at the S-GW due to the removal of Private Extension Overcharging Support.

Table 11: Previous Behavior and New Behavior: MBRsp Messages at the S-GW Due to the Removal of Private Extension Overcharging Support

Scenario No.	Old Behavior: IE Carrying OCP Capability Received from P-GW in MBRsp	New Behavior: IE Carrying OCP Capability Received from P-GW in MBRsp	Old Behavior: IE Carrying OCP Capability Sent to MME in MBRsp	New Behavior: IE Carrying OCP Capability Sent to MME in MBRsp
1	Indication IE	No change. OCP capability received as part of Indication IE is accepted.	Indication IE	No change. Indication IE is sent in MBRsp.

Scenario No.	Old Behavior: IE Carrying OCP Capability Received from P-GW in MBRsp	New Behavior: IE Carrying OCP Capability Received from P-GW in MBRsp	Old Behavior: IE Carrying OCP Capability Sent to MME in MBRsp	New Behavior: IE Carrying OCP Capability Sent to MME in MBRsp
2	Private Extension IE	OCP capability received as part of Private Extension IE is ignored.	If gtpc private-extension overcharge-protection is disabled at egtpc service level: None . If gtpc private-extension overcharge-protection is enabled at egtpc service level: Indication IE .	Since the CLI command is deprecated, neither one of the two IEs is sent in the MBRsp to the MME for the OCP capability.
3	Both Private Extension ID and Indication IE	OCP capability received as part of the Private Extension IE is ignored. Only the OCP capability received as part of the Indication IE is accepted.	Indication IE	No change. Indication IE is sent in MBRsp.
4	None	None	None	No change.



Important In StarOS releases 21.0 and later, the S-GW will send a MBReq message with only the indication IE for the Pause/Start Charging procedure. The private extension IE is not sent.



Important If the S-GW receives only the private extension IE from the P-GW in the CSRsp/MBRsp message, then the S-GW ignores the private extension IE. As a result, the S-GW assumes that Overcharging Protection is NOT enabled for the P-GW. So, in this scenario, even if the overcharging condition is met at the S-GW, the S-GW will not send a MBReq message for Charging pause to the P-GW.

S-GW Restoration Support

S-GW Restoration helps in handling the S-GW failure in the EPC network in a graceful manner. It allows affected PDNs due to S-GW failure to be restored by selecting another S-GW to serve the affected PDNs, thus avoiding unnecessary flooding of signaling for PDN cleanup.

S-GW Restoration is based on 3GPP Release 11. It requires enhancements at P-GW for maintaining the sessions in case path failure is detected or when S-GW restart is detected via recovery IE on GTP-C signaling. P-GW shall ensure that any dropped packets in this scenario are not charged and P-GW shall reject any bearer addition/modification request received for the PDN connection maintained after the S-GW failure detection, till the time that PDN is restored again.



Important If the S-GW Restoration feature is configured and enabled for a P-GW that is associated with an SAEGW service, the feature supports Pure-P calls only.

Once the session has been restored by the MME (i.e., P-GW receives a Modify Bearer Request from the restarted S-GW or a different S-GW), P-GW shall resume forwarding any received downlink data and start charging them.

When subscriber is in S-GW restoration phase, all RARs (except for Session Termination) will be rejected by PCEF. P-GW will reject all internal updates which can trigger CCR-U towards PCRF. P-GW shall trigger a CCR U with AN-GW-Change for the PDNs that are restored if the S-GW has changed on restoration.



Important Only the MME/S4-SGSN triggered S-GW restoration procedure is supported.

S-GW restoration detection based on GTP-U path failure shall not be considered for this release. GTP-C path failure detection should be enabled for enabling this feature.

MME/S4-SGSN is locally configured to know that P-GW in the same PLMN supports the S-GW restoration feature. When this feature is enabled at P-GW, it shall support it for all S-GWs/MMEs.

For more details on this feature, refer to the *S-GW Restoration Support* chapter in this guide.

Source IP Address Validation

Insures integrity between the attached subscriber terminal and the P-GW by mitigating the potential for unwanted spoofing or man-in-the-middle attacks.

The P-GW includes local IPv4/IPv6 address pools for assigning IP addresses to UEs on a per-PDN basis. The P-GW defends its provisioned address bindings by insuring that traffic is received from the host address that it has awareness of. In the event that traffic is received from a non-authorized host, the P-GW includes the ability to block the non-authorized traffic. The P-GW uses the IPv4 source address to verify the sender and the IPv6 source prefix in the case of IPv6.

SRVCC PS-to-CS Handover Indication Support

This feature helps in notifying the PCRF about the exact reason for PCC rule deactivation on Voice bearer deletion. This exact cause will help the PCRF to then take further action appropriately.

This feature ensures complete compliance for SRVCC, including support for PS-to-CS handover indication when voice bearers are released. The support for SRVCC feature was first added in StarOS Release 12.2.

SRVCC service for LTE comes into the picture when a single radio User Equipment (UE) accessing IMS-anchored voice call services switches from the LTE network to the Circuit Switched domain while it is able to transmit or receive on only one of these access networks at a given time. This removes the need for a UE to have multiple Radio Access Technology (RAT) capability.

After handing over the PS sessions to the target, the source MME shall remove the voice bearers by deactivating the voice bearer(s) towards S-GW/P-GW and setting the VB (Voice Bearer) flag of Bearer Flags IE in the Delete Bearer Command message (TS 29.274 v9.5.0).

If the IP-CAN bearer termination is caused by the PS to CS handover, the PCEF may report related PCC rules for this IP-CAN bearer by including the Rule-Failure-Code AVP set to the value PS_TO_CS_HANDOVER (TS 29.212 v10.2.0 and TS 23.203 v10.3.0).

Support for new AVP PS-to-CS-Session-Continuity (added in 3GPP Release 11) inside Charging Rule Install, which indicates if the bearer is selected for PS to CS continuity, is not added.

Subscriber Level Trace

Provides a 3GPP standards-based session level trace function for call debugging and testing new functions and access terminals in an LTE environment.

As a complement to Cisco's protocol monitoring function, the P-GW supports 3GPP standards based session level trace capabilities to monitor all call control events on the respective monitored interfaces including S5/S8, S2a, SGi, and Gx. The trace can be initiated using multiple methods:

- Management initiation via direct CLI configuration
- Management initiation at HSS with trace activation via authentication response messages over S6a reference interface
- Signaling based activation through signaling from subscriber access terminal



Important Once the trace is provisioned, it can be provisioned through the access cloud via various signaling interfaces.

The session level trace function consists of trace activation followed by triggers. The time between the two events is treated much like Lawful Intercept where the EPC network element buffers the trace activation instructions for the provisioned subscriber in memory using camp-on monitoring. Trace files for active calls are buffered as XML files using non-volatile memory on the local dual redundant hard drives on the ASR 5500 platform. The Trace Depth defines the granularity of data to be traced. Six levels are defined including Maximum, Minimum and Medium with ability to configure additional levels based on vendor extensions.

All call control activity for active and recorded sessions is sent to an off-line Trace Collection Entity (TCE) using a standards-based XML format over a FTP or secure FTP (SFTP) connection. In the current release the IPv4 interfaces are used to provide connectivity to the TCE. Trace activation is based on IMSI or IMEI. Once a subscriber level trace request is activated it can be propagated via the S5/S8 signaling to provision the corresponding trace for the same subscriber call on the P-GW. The trace configuration will only be propagated if the P-GW is specified in the list of configured Network Element types received by the S-GW. Trace configuration can be specified or transferred in any of the following message types:

- S5/S8: Create Session Request
- S5/S8: Modify Bearer Request
- S5/S8: Trace Session Activation (New message defined in TS 32.422)

Performance Goals: As subscriber level trace is a CPU intensive activity the max number of concurrently monitored trace sessions per Cisco P-GW is 32. Use in a production network should be restricted to minimize the impact on existing services.

3GPP tracing was enhanced in StarOS Release 15.0 to increase the number of simultaneous traces to 1000. The generated trace files are forwarded to external trace collection entity at regular intervals through (S)FTP

if "push" mode is enabled. If the push mode is not used, the files are stored on the local hard drive and must be pulled off by the TCE using FTP or SFTP.



Important The number of session trace files generated would be limited by the total available hard disk capacity.

3GPP Tracing to Intercept Random Subscriber

Previously, a subscriber identifier like IMSI was required in order to enable trace. Sometimes operators want to enable a trace without knowing the subscriber ID. For example, an operator may want to monitor the next "n" number of calls, or monitor subscribers in a particular IMSI range.

3GPP tracing was enhanced in StarOS Release 15.0 to intercept random subscribers with this feature. The current session trace feature is either signaling or management based, which is very specific to a particular subscriber. The requirement is to trace random subscribers which are not explicitly linked or identified by IMSI in GTP messages or configured through CLI.

The random subscribers could be in an IMSI range, context activation in particular time intervals, etc.

The session trace is activated on demand for a limited period of time for specific analysis purposes. The maximum limit would restrict the number of random subscriber tracing. Random session trace will be given priority over signaling and management-based session trace.

Support for One Million S1-U Peers on the S-GW

Due to customer business requirements and production forecasts, support has been added to the StarOS for one million S1-U connections on a single S-GW.

The S1-U interface is the user plane interface carrying user data between an eNodeB and an S-GW received from the terminal. The StarOS now has the capability to scale the number of S1-U peers to one million per VPN context.

A new CLI command has been added to enable operators to set the number of S1-U peers for which statistics should be collected. The limit is restricted to less than one million peers (128k) due to StarOS memory limitations.

How it Works

The gtpumgr uses the following guidelines while allocating peers:

- When a session installation comes from the Session Manager, a peer is created. If statistics are maintained at the Session Manager, the gtpumgr also creates the peer record with the statistics.
- Peer records are maintained per service.
- The number of peers is maintained at the gtpumgr instance level. The limit is one million S1-U peers per gtpumgr instance.
- If the limit of one million peers is exceeded, then peer creation fails. It causes a call installation failure in the gtpumgr, which leads to an audit failure if an audit is triggered.

The feature changes impact all the interfaces/services using the gtpu-service including GGSN/S4-SGSN/SGW/PGW/SAEGW/ePDG/SaMOG/HNB-GW/HeNB-GW for:

- The Gn and Gp interfaces of the General Packet Radio Service (GPRS)

- The Iu, Gn, and Gp interfaces of the UMTS system
- The S1-U, S2a, S2b, S4, S5, S8, and S12 interfaces of the Evolved Packet System (EPS)

Recovery/ICSR Considerations

- After a session manager/gtpmgr recovery or after an ICSR switchover, the same set of peers configured for statistics collection is recovered.
 - Peers with 0 sessions and without statistics are not recovered.
 - Peers with 0 sessions and with statistics are recovered.
 - Peers with Extension Header Support disabled are recovered.
- While upgrading from a previous release, ensure the newer release chassis **gtpu peer statistics threshold** is equal to or greater than the previous release. This ensures that the GTPU peer statistics are preserved during the upgrade. For example, if you are upgrading from release 19.0 to 20.2, and the 19.0 system has 17,000 GTPU sessions, then configure the threshold on the 20.2 chassis to 17,000 as well.

Configuration/Restrictions

- Due to the large number of GTP-U entities connecting to the StarOS, Cisco recommends disabling the GTP-U Path Management feature.
- The configured threshold is not the hard upper limit for statistics allocation because of the distributed nature of system. It is possible that total GTP-U peers with statistics exceeds the configured threshold value to some extent.
- It is assumed that all 1,000,000 peers are not connected to the node in a point-to-point manner. They are connected through routers.
- There will not be any ARP table size change for the StarOS to support this feature.

TCP Window Size



Important This feature is not fully qualified in this release. It is available only for testing purposes. For more information, contact your Cisco Accounts representative.

The operator can restrict the effective window size of all downlink TCP packets. A new CLI command **window-size** is added in the Rulebase Configuration mode to enable this feature.

The P-GW updates the TCP packets with the configured value if the effective window size is greater than the configured window size. Otherwise, the P-GW does not modify the window size of the packet.

The newly updated window size might not be the same as the configured window size because the P-GW does not have control over the Window Scale option (sent with SYN flag). Therefore, the updated window size is rounded off to the nearest value calculated by the Window Scale option.

This feature is not applicable on non-SYN flows as they do not have the Window Scale option is not available.

When TCP Window Size is enabled, Rulebase changes and configuration changes are applicable to both newly created flows and existing flows. The changes will not be applicable if TCP Window Size feature is not enabled for these flows.



Note There will be a performance impact as PGW updates every downlink packet for a specified Rulebase where the configured window size is lesser than the effective windows size in the packet.

Threshold Crossing Alerts (TCA) Support

Thresholding on the system is used to monitor the system for conditions that could potentially cause errors or outage. Typically, these conditions are temporary (i.e high CPU utilization, or packet collisions on a network) and are quickly resolved. However, continuous or large numbers of these error conditions within a specific time interval may be indicative of larger, more severe issues. The purpose of thresholding is to help identify potentially severe conditions so that immediate action can be taken to minimize and/or avoid system downtime.

The system supports Threshold Crossing Alerts for certain key resources such as CPU, memory, IP pool addresses, etc. With this capability, the operator can configure threshold on these resources whereby, should the resource depletion cross the configured threshold, a SNMP Trap would be sent.

The following thresholding models are supported by the system:

- **Alert:** A value is monitored and an alert condition occurs when the value reaches or exceeds the configured high threshold within the specified polling interval. The alert is generated then generated and/or sent at the end of the polling interval.
- **Alarm:** Both high and low threshold are defined for a value. An alarm condition occurs when the value reaches or exceeds the configured high threshold within the specified polling interval. The alert is generated then generated and/or sent at the end of the polling interval.

Thresholding reports conditions using one of the following mechanisms:

- **SNMP traps:** SNMP traps have been created that indicate the condition (high threshold crossing and/or clear) of each of the monitored values.

Generation of specific traps can be enabled or disabled on the chassis. Ensuring that only important faults get displayed. SNMP traps are supported in both Alert and Alarm modes.

- **Logs:** The system provides a facility called threshold for which active and event logs can be generated. As with other system facilities, logs are generated Log messages pertaining to the condition of a monitored value are generated with a severity level of WARNING.

Logs are supported in both the Alert and the Alarm models.

- **Alarm System:** High threshold alarms generated within the specified polling interval are considered "outstanding" until a the condition no longer exists or a condition clear alarm is generated. "Outstanding" alarms are reported to the system's alarm subsystem and are viewable through an element management system.

The Alarm System is used only in conjunction with the Alarm model.



Important For more information on threshold crossing alert configuration, refer to the *Thresholding Configuration Guide*.

UE Time Zone Reporting

This feature enables time-based charging for specialized service tariffs, such as super off-peak billing plans. Time Zone of the UE is associated with UE location (Tracking Area/Routing Area). The UE Time Zone Information Element is an attribute the MME tracks on a Tracking Area List basis and propagates over S11 and S5/S8 signaling to the P-GW.

Time zone reporting can be included in billing records or conveyed in Gx/Gy signaling to external PCRF and OCS servers.

Virtual APN Support

Virtual APNs allow differentiated services within a single APN.

The Virtual APN feature allows a carrier to use a single APN to configure differentiated services. The APN that is supplied by the MME is evaluated by the P-GW in conjunction with multiple configurable parameters. Then, the P-GW selects an APN configuration based on the supplied APN and those configurable parameters.

APN configuration dictates all aspects of a session at the P-GW. Different policies imply different APNs. After basic APN selection, however, internal re-selection can occur based on the following parameters:

- Service name
- Subscriber type
- MCC-MNC of IMSI
- Domain name part of username (user@domain)
- S-GW address



Important For more information, refer to the **virtual-apn preference** command in *APN Configuration Mode Commands* in the *Command Line Interface Reference*.

P-GW Features and Functionality - Inline Service Support

This section describes the features and functions of inline services supported on the P-GW. These services require additional licenses to implement the functionality.



Important The SAEGW supports all of these features if a P-GW service is assigned to the SAEGW service.

Content Filtering

The Cisco P-GW offers two variants of network-controlled content filtering / parental control services. Each approach leverages the native DPI capabilities of the platform to detect and filter events of interest from mobile subscribers based on HTTP URL or WAP/MMS URI requests:

- **Integrated Content Filtering:** A turnkey solution featuring a policy enforcement point and category based rating database on the Cisco P-GW. An offboard AAA or PCRF provides the per-subscriber content filtering information as subscriber sessions are established. The content filtering service uses DPI to extract URLs or URIs in HTTP request messages and compares them against a static rating database to determine the category match. The provisioned policy determines whether individual subscribers are entitled to view the content.
- **Content Filtering ICAP Interface:** This solution is appropriate for mobile operators with existing installations of Active Content Filtering external servers. The service continues to harness the DPI functions of the ASR 5500 platform to extract events of interest. However in this case, the extracted requests are transferred via the Integrated Content Adaptation Protocol (ICAP) with subscriber identification information to the external ACF server which provides the category rating database and content decision functions.

Integrated Adult Content Filter

Provides a value-added service to prevent unintended viewing of objectionable content that exploits underage children. Content Filtering offers mobile operators a way to increase data ARPU and subscriber retention through a network-based solution for parental controls and content filtering. The integrated solution enables a single policy decision and enforcement point thereby streamlining the number of signaling interactions with external AAA/Policy Manager servers. When used in parallel with other services such as Enhanced Content Charging (ECS) it increases billing accuracy of charging records by insuring that mobile subscribers are only charged for visited sites they are allowed to access.

The Integrated Adult Content Filter is a subscriber-aware inline service provisioned on an ASR 5500 running P-GW services. Integrated Content Filtering utilizes the local DPI engine and harnesses a distributed software architecture that scales with the number of active P-GW sessions on the system.

Content Filtering policy enforcement is the process of deciding if a subscriber should be able to receive some content. Typical options are to allow, block, or replace/redirect the content based on the rating of the content and the policy defined for that content and subscriber. The policy definition is transferred in an authentication response from a AAA server or Diameter policy message via the Gx reference interface from an adjunct PCRF. The policy is applied to subscribers through rulebase or APN/Subscriber configuration. The policy determines the action to be taken on the content request on the basis of its category. A maximum of one policy can be associated with a rulebase.

ICAP Interface

Provides a value-added service to prevent unintended viewing of objectionable content that exploits underage children. Content Filtering offers mobile operators a way to increase data ARPU and subscriber retention through a network-based solution for parental controls and content filtering. The Content Filtering ICAP solution is appropriate for operators with existing installations of Active Content Filtering servers in their networks.

The Enhanced Charging Service (ECS) for the P-GW provides a streamlined Internet Content Adaptation Protocol (ICAP) interface to leverage the Deep Packet Inspection (DPI) to enable external Application Servers to provide their services without performing the DPI functionality and without being inserted in the data flow.

The ICAP interface may be attractive to mobile operators that prefer to use an external Active Content Filtering (ACF) Platform. If a subscriber initiates a WAP (WAP1.x or WAP2.0) or Web session, the subsequent GET/POST request is detected by the deep packet inspection function. The URL of the GET/POST request is extracted by the local DPI engine on the ASR 5500 platform and passed, along with subscriber identification information and the subscriber request, in an ICAP message to the Application Server (AS). The AS checks the URL on the basis of its category and other classifications like, type, access level, content category and decides if the request should be authorized, blocked or redirected by answering the GET/POST message. Depending upon the response received from the ACF server, the P-GW either passes the request unmodified or discards the message and responds to the subscriber with the appropriate redirection or block message.

Header Enrichment: Header Insertion and Encryption

Header enrichment provides a value-added capability for mobile operators to monetize subscriber intelligence to include subscriber-specific information in the HTTP requests to application servers.

Extension header fields (x-header) are the fields that can be added to headers of a protocol for a specific purpose. The enriched header allows additional entity-header fields to be defined without changing the protocol, but these fields cannot be assumed to be recognizable by the recipient. Unrecognized fields should be ignored by the recipient and must be forwarded by transparent proxies.

Extension headers can be supported in HTTP/WSP GET and POST request packets. The Enhanced Charging Service (ECS) for the P-GW offers APN-based configuration and rules to insert x-headers in HTTP/WSP GET and POST request packets. The charging action associated with the rules will contain the list of x-headers to be inserted in the packets. Protocols supported are HTTP, WAP 1.0 and WAP 2.0 GET, and POST messages.



Important For more information on ECS, see the *Enhanced Charging Service Administration Guide*.

The data passed in the inserted HTTP header attributes is used by end application servers (also known as Upsell Servers) to identify subscribers and session information. These servers provide information customized to that specific subscriber.

The Cisco P-GW can include the following information in the http header:

- User-customizable, arbitrary text string
- Subscriber's MSISDN (the RADIUS calling-station-id, in clear text)
- Subscriber's IMSI
- Subscriber's IP address
- S-GW IP address (in clear text)

X-Header encryption enhances the header enrichment feature by increasing the number of fields that can be supported and through encryption of the fields before inserting them.

The following limitations to insertion of x-header fields in WSP headers apply:

- x-header fields are not inserted in IP fragmented packets before StarOS v14.0.
- In case of concatenated request, x-header fields are only inserted in first GET or POST request (if rule matches for the same). X-header fields are not inserted in the second or later GET/POST requests in the concatenated requests. For example, if there is ACK+GET in packet, x-header is inserted in the GET

packet. However, if GET1+GET2 is present in the packet and rule matches for GET2 and not GET1 x-header is still inserted in GET2. In case of GET+POST also, x-header is not inserted in POST.

- In case of CO, x-header fields are not inserted if the WTP packets are received out of order (even after proper reordering).
- If route to MMS is present, x-headers are not inserted.
- x-headers are not inserted in WSP POST packet when header is segmented. This is because POST contains header length field which needs to be modified after addition of x-headers. In segmented WSP headers, header length field may be present in one packet and header may complete in another packet.

Network Address Translation (NAT)

NAT translates non-routable private IP address(es) to routable public IP address(es) from a pool of public IP addresses that have been designated for NAT. This enables to conserve on the number of public IP addresses required to communicate with external networks, and ensures security as the IP address scheme for the internal network is masked from external hosts, and each outgoing and incoming packet goes through the translation process.

NAT works by inspecting both incoming and outgoing IP datagrams and, as needed, modifying the source IP address and port number in the IP header to reflect the configured NAT address mapping for outgoing datagrams. The reverse NAT translation is applied to incoming datagrams.

NAT can be used to perform address translation for simple IP and mobile IP. NAT can be selectively applied/denied to different flows (5-tuple connections) originating from subscribers based on the flows' L3/L4 characteristics—Source-IP, Source-Port, Destination-IP, Destination-Port, and Protocol.

NAT supports the following mappings:

- One-to-One
- Many-to-One



Important For more information on NAT, refer to the *Network Address Translation Administration Guide*.

NAT64 Support

This feature helps facilitate the co-existence and gradual transition to IPv6 addressing scheme in the networks. Use of NAT64 requires that a valid license key be installed. Contact your Cisco account representative for information on how to obtain a license.

With the dwindling IPv4 public address space and the growing need for more routable addresses, service providers and enterprises will continue to build and roll out IPv6 networks. However, because of the broad scale IPv4 deployment, it is not practical that the world changes to IPv6 overnight. There is need to protect the IPv4 investment combined with the need to expand and grow the network will force IPv4 and IPv6 networks to co-exist together for a considerable period of time and keep end-user experience seamless.

The preferred approaches are to run dual stacks (both IPv4 and IPv6) on the end hosts, dual stack routing protocols, and dual stack friendly applications. If all of the above is available, then the end hosts will communicate natively using IPv6 or IPv4 (using NAT). Tunneling through the IPv4 or IPv6 is the next

preferred method to achieve communication wherever possible. When all these options fail, translation is recommended.

Stateful NAT64 is a mechanism for translating IPv6 packets to IPv4 packets and vice-versa. The system supports a Stateful NAT64 translator based on IETF Behave WG drafts whose framework is described in draft-ietf-behave-v6v4-framework-10. Stateful NAT64 is available as part of the existing NAT licenses from the current system implementation. The NAT44 and NAT64 will co-exist on the chassis and share the resources needed for NATing.

Peer-to-Peer Detection

Enables operators to identify P2P traffic in the network and applying appropriate controlling functions to ensure fair distribution of bandwidth to all subscribers.

Peer-to-Peer (P2P) is a term used in two slightly different contexts. At a functional level, it means protocols that interact in a peering manner, in contrast to client-server manner. There is no clear differentiation between the function of one node or another. Any node can function as a client, a server, or both—a protocol may not clearly differentiate between the two. For example, peering exchanges may simultaneously include client and server functionality, sending and receiving information.

Detecting peer-to-peer protocols requires recognizing, in real time, some uniquely identifying characteristic of the protocols. Typical packet classification only requires information uniquely typed in the packet header of packets of the stream(s) running the particular protocol to be identified. In fact, many peer-to-peer protocols can be detected by simple packet header inspection. However, some P2P protocols are different, preventing detection in the traditional manner. This is designed into some P2P protocols to purposely avoid detection. The creators of these protocols purposely do not publish specifications. A small class of P2P protocols is stealthier and more challenging to detect. For some protocols no set of fixed markers can be identified with confidence as unique to the protocol.

Operators care about P2P traffic because of the behavior of some P2P applications (for example, Bittorrent, Skype, and eDonkey). Most P2P applications can hog the network bandwidth such that 20% P2P users can generate as much as traffic generated by the rest 80% non-P2P users. This can result into a situation where non-P2P users may not get enough network bandwidth for their legitimate use because of excess usage of bandwidth by the P2P users. Network operators need to have dynamic network bandwidth / traffic management functions in place to ensure fair distributions of the network bandwidth among all the users. And this would include identifying P2P traffic in the network and applying appropriate controlling functions to the same (for example, content-based premium billing, QoS modifications, and other similar treatments).

Cisco's P2P detection technology makes use of innovative and highly accurate protocol behavioral detection techniques.



Important For more information on peer-to-peer detection, refer to the *Application Detection and Control Administration Guide*.

Personal Stateful Firewall

The Personal Stateful Firewall is an in-line service feature that inspects subscriber traffic and performs IP session-based access control of individual subscriber sessions to protect the subscribers from malicious security attacks.

The Personal Stateful Firewall supports stateless and stateful inspection and filtering based on the configuration.

In stateless inspection, the firewall inspects a packet to determine the 5-tuple—source and destination IP addresses and ports, and protocol—information contained in the packet. This static information is then compared against configurable rules to determine whether to allow or drop the packet. In stateless inspection the firewall examines each packet individually, it is unaware of the packets that have passed through before it, and has no way of knowing if any given packet is part of an existing connection, is trying to establish a new connection, or is a rogue packet.

In stateful inspection, the firewall not only inspects packets up through the application layer / layer 7 determining a packet's header information and data content, but also monitors and keeps track of the connection's state. For all active connections traversing the firewall, the state information, which may include IP addresses and ports involved, the sequence numbers and acknowledgment numbers of the packets traversing the connection, TCP packet flags, etc. is maintained in a state table. Filtering decisions are based not only on rules but also on the connection state established by prior packets on that connection. This enables to prevent a variety of DoS, DDoS, and other security violations. Once a connection is torn down, or is timed out, its entry in the state table is discarded.

The Enhanced Charging Service (ECS) / Active Charging Service (ACS) in-line service is the primary vehicle that performs packet inspection and charging. For more information on ECS, see the *Enhanced Charging Service Administration Guide*.



Important For more information on Personal Stateful Firewall, refer to the *Personal Stateful Firewall Administration Guide*.

S-GW Features and Functionality - Optional Enhanced Feature Software

This section describes the optional enhanced features and functions for the S-GW service.



Important The SAEGW supports all of these features if an S-GW service is assigned to the SAEGW service.

Each of the features described in this section requires the purchase of an additional license to implement the functionality with the S-GW service.

Direct Tunnel

In accordance with standards, one tunnel functionality enables the SGSN to establish a direct tunnel at the user plane level - a GTP-U tunnel, directly between the RAN and the S-GW.

Figure 34: GTP-U with Direct Tunnel

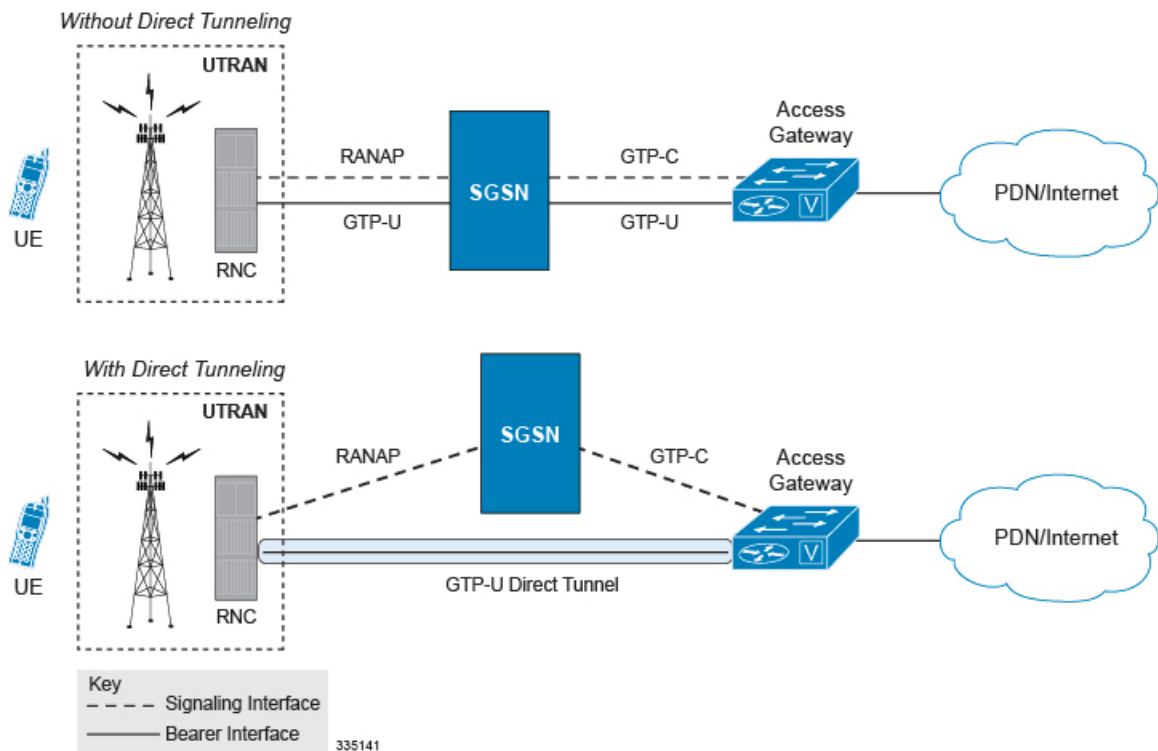

In effect, a direct tunnel reduces data plane latency as the tunnel functionality acts to remove the SGSN from the data plane and limit the SGSN to the control plane for processing. This improves the user experience (for example, expedites web page delivery, reduces round trip delay for conversational services). Additionally, direct tunnel functionality implements the standard SGSN optimization to improve the usage of user plane resources (and hardware) by removing the requirement from the SGSN to handle the user plane processing.

Typically, the SGSN establishes a direct tunnel at PDP context activation using an Update PDP Context Request towards the S-GW. This means a significant increase in control plane load on both the SGSN and S-GW components of the packet core. Hence, deployment requires highly scalable S-GWs since the volume and frequency of Update PDP Context messages to the S-GW will increase substantially. The ASR 5500 platform capabilities ensure control plane capacity will not be a limiting factor with direct tunnel deployment.



Important For more information on direct tunnel support, refer to the *Direct Tunnel for 4G (LTE) Networks* chapter in this guide.

Intelligent Paging for ISR

In case of when Idle-mode Signaling Reduction (ISR) active and the UE is idle, the S-GW will send Downlink Data Notification (DDN) Message to both the MME and the S4-SGSN if it receives the downlink data or network initiated control message for this UE. In turn, the MME and the S4-SGSN would do paging in parallel consuming radio resources.

To optimize the radio resource, the S-GW will now perform intelligent paging. When configured at the S-GW service level for each APN, the S-GW will page in a semi-sequential fashion (one by one to peer MME or S4-SGSN based on last known RAT type) or parallel to both the MME and S4-SGSN.

Inter-Chassis Session Recovery

The ASR 5500 platform provide industry leading carrier class redundancy. The systems protects against all single points of failure (hardware and software) and attempts to recover to an operational state when multiple simultaneous failures occur.

The system provides several levels of system redundancy:

- Under normal N+1 packet processing card hardware redundancy, if a catastrophic packet processing card failure occurs all affected calls are migrated to the standby packet processing card if possible. Calls which cannot be migrated are gracefully terminated with proper call-termination signaling and accounting records are generated with statistics accurate to the last internal checkpoint
- If the Session Recovery feature is enabled, any total packet processing card failure will cause a packet processing card switchover and all established sessions for supported call-types are recovered without any loss of session.

Even though Cisco provides excellent intra-chassis redundancy with these two schemes, certain catastrophic failures which can cause total chassis outages, such as IP routing failures, line-cuts, loss of power, or physical destruction of the chassis, cannot be protected by this scheme. In such cases, the MME Inter-Chassis Session Recovery (ICSR) feature provides geographic redundancy between sites. This has the benefit of not only providing enhanced subscriber experience even during catastrophic outages, but can also protect other systems such as the RAN from subscriber re-activation storms.

ICSR allows for continuous call processing without interrupting subscriber services. This is accomplished through the use of redundant chassis. The chassis are configured as primary and backup with one being active and one in recovery mode. A checkpoint duration timer is used to control when subscriber data is sent from the active chassis to the inactive chassis. If the active chassis handling the call traffic goes out of service, the inactive chassis transitions to the active state and continues processing the call traffic without interrupting the subscriber session. The chassis determines which is active through a propriety TCP-based connection called a redundancy link. This link is used to exchange Hello messages between the primary and backup chassis and must be maintained for proper system operation.

Interchassis Communication

Chassis configured to support ICSR communicate using periodic Hello messages. These messages are sent by each chassis to notify the peer of its current state. The Hello message contains information about the chassis such as its configuration and priority. A dead interval is used to set a time limit for a Hello message to be received from the chassis' peer. If the standby chassis does not receive a Hello message from the active chassis within the dead interval, the standby chassis transitions to the active state. In situations where the redundancy link goes out of service, a priority scheme is used to determine which chassis processes the session. The following priority scheme is used:

- router identifier
- chassis priority
- SPIO MAC address

Checkpoint Messages

Checkpoint messages are sent from the active chassis to the inactive chassis. Checkpoint messages are sent at specific intervals and contain all the information needed to recreate the sessions on the standby chassis, if that chassis were to become active. Once a session exceeds the checkpoint duration, checkpoint data is collected on the session. The checkpoint parameter determines the amount of time a session must be active before it is included in the checkpoint message.



Important For more information on inter-chassis session recovery support, refer to the *Interchassis Session Recovery* chapter in *System Administration Guide*.

IP Security (IPSec) Encryption

Enables network domain security for all IP packet switched LTE-EPC networks in order to provide confidentiality, integrity, authentication, and anti-replay protection. These capabilities are insured through use of cryptographic techniques.

The Cisco S-GW supports IKEv1 and IPSec encryption using IPv4 addressing. IPSec enables the following two use cases:

- Encryption of S8 sessions and EPS bearers in roaming applications where the P-GW is located in a separate administrative domain from the S-GW
- IPSec ESP security in accordance with 3GPP TS 33.210 is provided for S1 control plane, S1 bearer plane and S1 management plane traffic. Encryption of traffic over the S1 reference interface is desirable in cases where the EPC core operator leases radio capacity from a roaming partner's network.



Important You must purchase an IPSec license to enable IPSec. For more information on IPSec support, refer to the *IP Security (IPSec) Reference*.

Lawful Intercept

The Cisco Lawful Intercept feature is supported on the S-GW. Lawful Intercept is a licensed-enabled, standards-based feature that provides telecommunications service providers with a mechanism to assist law enforcement agencies in monitoring suspicious individuals for potential illegal activity. For additional information and documentation on the Lawful Intercept feature, contact your Cisco account or support representative.

Layer 2 Traffic Management (VLANs)

Virtual LANs (VLANs) provide greater flexibility in the configuration and use of contexts and services.

VLANs are configured as tags on a per-port basis and allow more complex configurations to be implemented. The VLAN tag allows a single physical port to be bound to multiple logical interfaces that can be configured in different contexts. Therefore, each Ethernet port can be viewed as containing many logical ports when VLAN tags are employed.



Important For more information on VLAN support, refer to the VLANs chapter in the *System Administration Guide*.

New Call Policy for Stale Sessions

Use of new call policy for stale sessions requires that a valid license key be installed. Contact your Cisco Account or Support representative for information on how to obtain a license.

If the newcall policy is set to **reject release-existing-session** and there are pre-existing sessions for the IMSI/IMEI received in Create Session Req, they will be deleted. This allows for no hung sessions on a node with newcall policy reject release configured. When GGSN/P-GW/SAEGW/S-GW releases the existing call, it follows a proper release process of sending Accounting Stop, sending CCR-T to PCRF/OCS, and generating CDR(s).

New Standard QCI Support

New Standard QCI Support is a license-controlled feature. Contact your Cisco account or support representative for licensing details.

The P-GW/SAEGW/S-GW support additional new 3GPP-defined standard QCIs. QCIs 65, 66, 69, and 70 are now supported for Mission Critical and Push-to-Talk (MC/PTT) applications. These new standard QCIs are supported in addition to the previously supported QCIs of 1 through 9, and operator-defined QCIs 128 through 254.

The StarOS will continue to reject QCIs 10 through 127 sent by the PCRF.

For detailed information on this feature, refer to the *New Standard QCI Support* chapter in this guide.

Overcharging Protection Support

Use of Overcharging Protection requires that a valid license key be installed. Contact your Cisco account representative for information on how to obtain a license.

Overcharging Protection helps in avoiding charging the subscribers for dropped downlink packets while the UE is in idle mode. In some countries, it is a regulatory requirement to avoid such overcharging, so it becomes a mandatory feature for operators in such countries. Overall, this feature helps ensure subscriber are not overcharged while the subscriber is in idle mode.



Important This feature is supported on the P-GW, and S-GW. Overcharging Protection is supported on the SAEGW only if the SAEGW is configured for Pure P or Pure S functionality.

The P-GW will never be aware of UE state (idle or connected mode). Charging for downlink data is applicable at P-GW, even when UE is in idle mode. Downlink data for UE may be dropped at S-GW when UE is in idle mode due to buffer overflow or delay in paging. Thus, P-GW will charge the subscriber for the dropped packets, which isn't desired. To address this problem, with Overcharging Protection feature enabled, S-GW will inform P-GW to stop or resume charging based on packets dropped at S-GW and transition of UE from idle to active state.

If the S-GW supports the Overcharging Protection feature, then it will send a CSReq with the PDN Pause Support Indication flag set to 1 in an Indication IE to the P-GW.

If the PGW supports the Overcharging Protection feature then it will send a CSRsp with the PDN Pause Support Indication flag set to 1 in Indication IE and/or private extension IE to the S-GW.

Once the criterion to signal "stop charging" is met, S-GW will send Modify Bearer Request (MBReq) to P-GW. MBReq would be sent for the PDN to specify which packets will be dropped at S-GW. The MBReq will have an indication IE and/or a new private extension IE to send "stop charging" and "start charging" indication to P-GW. For Pause/Start Charging procedure (S-GW sends MBReq), MBRes from P-GW will have indication and/or private extension IE with Overcharging Protection information.

When the MBReq with stop charging is received from a S-GW for a PDN, P-GW will stop charging for downlink packets but will continue sending the packets to S-GW.

P-GW will resume charging downlink packets when either of these conditions is met:

- When the S-GW (which had earlier sent "stop charging" in MBReq) sends "start charging" in MBReq.
- When the S-GW changes (which indicates that maybe UE has relocated to new S-GW).

This feature aligns with the 3GPP TS 29.274: 3GPP Evolved Packet System (EPS); Evolved General Packet Radio Service (GPRS) Tunneling Protocol for Control plane (GTPv2-C) specification.

For detailed information on this feature, refer to the *Overcharging Protection Support* chapter in this guide.

Paging Policy Differentiation

This feature requires that a valid license key be installed. Contact your Cisco Account or Support representative for information on how to obtain a license.

S-GW/P-GW provide configuration control to change the DSCP value of the user-datagram packet and outer IP packet (GTP-U tunnel IP header). DSCP marking is done at various levels depending on the configuration. When the Paging Policy Differentiation (PPD) feature is enabled, however, the user-datagram packet DSCP (tunneled IP packet) marking does not change.

Currently, standards specify QCI to DSCP marking of outer GTP-U header only. All configurations present at ECS, P-GW, and S-GW to change the user-datagram packet DSCP value are non-standard. The standards-based PPD feature dictates that P-CSCF or similar Gi entity marks the DSCP of user-datagram packet. This user-datagram packet DSCP value is sent in DDN message by S-GW to MME/S4-SGSN. MME/S4-SGSN uses this DSCP value to give paging priority.



Important P-GW and S-GW should apply the PPD feature for both Default and Dedicated bearers. As per the specifications, P-GW transparently passes the user-datagram packet towards S-GW. This means, if PPD feature is enabled, operator can't apply different behavior for Default and Dedicated bearers.



Important For more information on paging policy differentiation, refer to the *Paging Policy Differentiation* chapter in this guide.

R12 Load and Overload Support

Use of R12 Load and Overload Support requires that a valid license key be installed. Contact your Cisco account representative for information on how to obtain a license.

GTP-C Load Control feature is an optional feature which allows a GTP control plane node to send its Load Information to a peer GTP control plane node which the receiving GTP control plane peer node uses to augment existing GW selection procedure for the P-GW and S-GW. Load Information reflects the operating status of the resources of the originating GTP control plane node.

Nodes using GTP control plane signaling may support communication of Overload control Information in order to mitigate overload situation for the overloaded node through actions taken by the peer node(s). This feature is supported over the S5 and S8 interfaces via the GTPv2 control plane protocol.

A GTP-C node is considered to be in overload when it is operating over its nominal capacity resulting in diminished performance (including impacts to handling of incoming and outgoing traffic). Overload control Information reflects an indication of when the originating node has reached such a situation. This information, when transmitted between GTP-C nodes may be used to reduce and/or throttle the amount of GTP-C signaling traffic between these nodes. As such, the Overload control Information provides guidance to the receiving node to decide actions, which leads to mitigation towards the sender of the information.

In brief, load control and overload control can be described in this manner:

- Load control enables a GTP-C entity (for example, an S-GW/P-GW) to send its load information to a GTP-C peer (e.g. an MME/SGSN, ePDG, TWAN) to adaptively balance the session load across entities supporting the same function (for example, an S-GW cluster) according to their effective load. The load information reflects the operating status of the resources of the GTP-C entity.
- Overload control enables a GTP-C entity becoming or being overloaded to gracefully reduce its incoming signaling load by instructing its GTP-C peers to reduce sending traffic according to its available signaling capacity to successfully process the traffic. A GTP-C entity is in overload when it operates over its signaling capacity, which results in diminished performance (including impacts to handling of incoming and outgoing traffic).

A maximum of 64 different load and overload profiles can be configured.



Important R12 Load and Overload Support is a license-controlled feature. Contact your Cisco representative for more information on licensing requirements.

R12 Load and Overload Factor Calculation Enhancement

In capacity testing and also in customer deployments it was observed that the chassis load factor for the R12 Load and Overload Support feature was providing incorrect values even when the sessmgr card CPU utilization was high. The root cause is that when the load factor was calculated by taking an average of CPU utilization of sessmgr and demux cards, the demux card CPU utilization never increased more than the sessmgr card CPU utilization. As a result, the system did not go into the overload state even when the sessmgr card CPU utilization was high.

The R12 Load/Overload Control Profile feature has been enhanced to calculate the load factor based on the higher value of similar types of cards for CPU load and memory. If the demux card's CPU utilization value is higher than the sessmgr card's CPU utilization value, then the demux card CPU utilization value is used for the load factor calculation.

A new CLI command is introduced to configure different polling intervals for the resource manager so that the demuxmgr can calculate the load factor based on different system requirements.



Important For more information on this feature, refer to the *GTP-C Load and Overload Control Support on the P-GW, SAEGW, and S-GW* chapter in this guide.

Operation

The node periodically fetches various parameters (for example, License-Session-Utilization, System-CPU-Utilization and System-Memory-Utilization), which are required for Node level load control information. The node then calculates the load control information itself either based on the weighted factor provided by the user or using the default weighted factor.

Node level load control information is calculated every 30 seconds. The resource manager calculates the system-CPU-utilization and System-Memory-Utilization at a systems level.

For each configured service, load control information can be different. This can be achieved by providing a weightage to the number of active session counts per service license, for example, $((\text{number of active sessions per service} / \text{max session allowed for the service license}) * 100)$.

The node's resource manager calculates the system-CPU-utilization and System-Memory-Utilization at a systems level by averaging CPU and Memory usage for all cards and which might be different from that calculated at the individual card level.

Separate Paging for IMS Service Inspection

Use of Separate Paging for IMS Service Inspection requires that a valid license key be installed. Contact your Cisco account or support representative for information on how to obtain a license.

When some operators add an additional IMS service besides VoLTE such as RCS, they can use the same IMS bearer between the two services. In this case, separate paging is supported at the MME using an ID which can be assigned from the S-GW according to the services, where the S-GW distinguishes IMS services using a small DPI function to inspect where the traffic comes from using an ID which is assigned from SGW according to the services. The S-GW distinguishes IMS services using a small DPI function to inspect where the traffic comes from (for example IP, Port and so on). After the MME receives this ID from the S-GW after IMS service inspection, the MME will do classified separate paging for each of the services as usual.

Session Recovery Support

Provides seamless failover and reconstruction of subscriber session information in the event of a hardware or software fault within the system preventing a fully connected user session from being disconnected.

In the telecommunications industry, over 90 percent of all equipment failures are software-related. With robust hardware failover and redundancy protection, any card-level hardware failures on the system can quickly be corrected. However, software failures can occur for numerous reasons, many times without prior indication. The StarOS has the ability to support stateful intra-chassis session recovery (ICSR) for S-GW sessions.

When session recovery occurs, the system reconstructs the following subscriber information:

- Data and control state information required to maintain correct call behavior
- Subscriber data statistics that are required to ensure that accounting information is maintained

- A best-effort attempt to recover various timer values such as call duration, absolute time, and others

Session recovery is also useful for in-service software patch upgrade activities. If session recovery is enabled during the software patch upgrade, it helps to preserve existing sessions on the active packet services card during the upgrade process.



Important For more information on session recovery support, refer to the *Session Recovery* chapter in the *System Administration Guide*.

S-GW Paging Enhancements

Use of S-GW Paging requires that a valid license key be installed. Contact your Cisco account representative for information on how to obtain a license.

S-GW Paging includes the following scenarios:

Scenario 1: S-GW sends a DDN message to the MME/S4-SGSN nodes. MME/S4-SGSN responds to the S-GW with a DDN Ack message. While waiting for the DDN Ack message from the MME/S4-SGSN, if the S-GW receives a high priority downlink data, it does not resend a DDN to the MME/S4-SGSN.

Scenario 2: If a DDN is sent to an MME/S4-SGSN and TAU/RAU MBR is received from another MME/S4-SGSN, S-GW does not send DDN.

Scenario 3: DDN is sent to an MME/S4-SGSN and DDN Ack with Cause #110 is received. DDN Ack with cause 110 is treated as DDN failure and standard DDN failure action procedure is initiated.

To handle these scenarios, the following two enhancements have been added to the DDN functionality:

- High Priority DDN at S-GW
- MBR-DDN Collision Handling

These enhancements support the following:

- Higher priority DDN on S-GW and SAEGW, which helps MME/S4-SGSN to prioritize paging.
- Enhanced paging KPI and VoLTE services.
- DDN message and mobility procedure so that DDN is not lost.
- MBR guard timer, which is started when DDN Ack with temporary HO is received. A new CLI command **ddn temp-ho-rejection mbr-guard-timer** has been introduced to enable the guard timer to wait for MBR once the DDN Ack with cause #110 (Temporary Handover In Progress) is received.
- TAU/RAU with control node change triggered DDNs.

In addition to the above functionality, to be compliant with 3GPP standards, support has been enhanced for Downlink Data Notification message and Mobility procedures. As a result, DDN message and downlink data which triggers DDN is not lost. This helps improve paging KPI and VoLTE success rates in scenarios where DDN is initiated because of SIP invite data.



Important For more information on this functionality, refer to the *S-GW Paging Enhancements* chapter in this guide.

P-GW Features and Functionality - Optional Enhanced Feature Software

This section describes the optional enhanced features and functions for the P-GW service.



Important The SAEGW supports all of these features if a P-GW service is assigned to the SAEGW service.

Each of the following features requires the purchase of an additional license to implement the functionality with the P-GW service.



Important For information on installing and verifying licenses, refer to the *Managing License Keys* section of the *Software Management Operations* chapter in the *System Administration Guide*.

AAA and Prefix Delegation DHCP Correlation

This feature requires that a valid license key be installed. Contact your Cisco Account or Support representative for information on how to obtain a license.

Currently at the DHCP server, DHCPv6 does not provide any mechanism to correlate allocated IPv6 (/64) prefix to a particular subscriber. This feature correlates the default prefix allocated from AAA server with the delegated prefix allocated from external DHCPv6 server during the PDN connection setup.

Options are available in DHCP Client Profile Configuration Mode to enable P-GW to send USER_CLASS_OPTION in DHCPv6 messages to external DHCPv6 server during delegated prefix setup.

APN Backoff Timer Support

Previously, the P-GW did not distinguish signaling traffic from Delay Tolerant or Low Priority devices such as low priority machine-to-machine traffic.

The UE was able to indicate its device profile to the MME via NAS and Attach Request messages. The MME was able to pass this information to the P-GW via the Signaling Priority Indication Information Element (IE) on the S5 interface. Some UEs may not have supported providing the Signaling Priority Indication IE on S5 interface to the P-GW. As a result, the P-GW could not distinguish between the signaling types. the current release, the P-GW can distinguish between these signaling types.

Also, during overload situations, the P-GW previously allowed new sessions from LAPI devices and treated the traffic from Low Access Priority Indicator (LAPI) devices with the same priority as the normal UEs. With the current StarOS release, during overload conditions, the P-GW can be configured to backoff the traffic that is identified as LAPI. The identification is based on either the APN configuration or the signaling priority indicator IE.

The backoff timer algorithm and the R12 GTP-C Load/Overload Control algorithm now work together. This feature provides the benefit of rejecting low priority calls, which, in turn allows for more bandwidth for high priority calls.

For additional information, refer to the *APN Backoff Timer Support* chapter in this guide.

Cause IE Enhancement for Delete Bearer Request

Use of Cause IE Enhancement for Delete Bearer Request requires that a valid license key be installed. Contact your Cisco account representative for information on how to obtain a license.

The cause value in the Delete Bearer Request previously had been limited. The behavior impacted by this feature is:

- Delete Bearer Request/Delete PDP Context due to idle-timer/session-timer expiration
- Delete Bearer Request due to bearer inactivity of default bearer
- Delete PDP Context due to bearer inactivity of the last PDP context of PDN connection
- Delete Bearer Request/Delete PDP Context triggered by **clear subscriber** CLI command

Configuration now is available to set cause values and cause inclusion in the following scenarios:

- CLI-based trigger to disconnect
- per APN when P-GW initiated disconnection for above mentioned timer expiry



Important This feature allows operator to override existing behavior. Such overridden behavior may not be compliant with standards.

Dynamic RADIUS Extensions (Change of Authorization)

Use of Dynamic RADIUS Extensions (CoA and PoD) requires that a valid license key be installed. Contact your Cisco account or support representative for information on how to obtain a license.

Dynamic RADIUS extension support provides operators with greater control over subscriber PDP contexts by providing the ability to dynamically redirect data traffic, and or disconnect the PDP context.

This functionality is based on the RFC 3576, Dynamic Authorization Extensions to Remote Authentication Dial In User Service (RADIUS), July 2003 standard.

The system supports the configuration and use of the following dynamic RADIUS extensions:

- **Change of Authorization:** The system supports CoA messages from the AAA server to change data filters associated with a subscriber session. The CoA request message from the AAA server must contain attributes to identify NAS and the subscriber session and a data filter ID for the data filter to apply to the subscriber session.
- **Disconnect Message:** The DM message is used to disconnect subscriber sessions in the system from a RADIUS server. The DM request message should contain necessary attributes to identify the subscriber session.

The above extensions can be used to dynamically re-direct subscriber PDP contexts to an alternate address for performing functions such as provisioning and/or account set up. This functionality is referred to as Session Redirection, or Hotlining.

Session redirection provides a means to redirect subscriber traffic to an external server by applying ACL rules to the traffic of an existing or a new subscriber session. The destination address and optionally the destination

port of TCP/IP or UDP/IP packets from the subscriber are rewritten so the packet is forwarded to the designated redirected address.

Return traffic to the subscriber has the source address and port rewritten to the original values. The redirect ACL may be applied dynamically by means of the Radius Change of Authorization (CoA) extension.



Important For more information on dynamic RADIUS extensions support, refer to the *CoA, RADIUS, And Session Redirection (Hotlining)* chapter in this guide.

GRE Protocol Interface Support

Use of GRE Interface Tunneling requires that a valid license key be installed. Contact your local Sales or Support representative for information on how to obtain a license.

The P-GW supports GRE generic tunnel interfaces in accordance with RFC 2784, Generic Routing Encapsulation (GRE). The GRE protocol allows mobile users to connect to their enterprise networks through GRE tunnels.

GRE tunnels can be used by the enterprise customers of a carrier 1) To transport AAA packets corresponding to an APN over a GRE tunnel to the corporate AAA servers and, 2) To transport the enterprise subscriber packets over the GRE tunnel to the corporation gateway.

The corporate servers may have private IP addresses and hence the addresses belonging to different enterprises may be overlapping. Each enterprise needs to be in a unique virtual routing domain, known as VRF. To differentiate the tunnels between same set of local and remote ends, GRE Key will be used as a differentiation.

GRE tunneling is a common technique to enable multi-protocol local networks over a single-protocol backbone, to connect non-contiguous networks and allow virtual private networks across WANs. This mechanism encapsulates data packets from one protocol inside a different protocol and transports the data packets unchanged across a foreign network. It is important to note that GRE tunneling does not provide security to the encapsulated protocol, as there is no encryption involved (like IPSec offers, for example).

GRE tunneling consists of three main components:

- Passenger protocol-protocol being encapsulated. For example: CLNS, IPv4 and IPv6.
- Carrier protocol-protocol that does the encapsulating. For example: GRE, IP-in-IP, L2TP, MPLS and IPSec.
- Transport protocol-protocol used to carry the encapsulated protocol. The main transport protocol is IP.



Important For more information on GRE protocol interface support, refer to the *GRE Protocol Interface* chapter in this guide.

GTP-Based S2a Interface Support on the SAEGW



Important GTP-Based S2a Interface Support on the SAEGW is a licensed controlled feature. Contact your Cisco account or support representative for detailed licensing information.

GTP-based S2a interface support is also supported on the SAEGW. When the WLAN is considered as trusted by the operator, the Trusted WLAN Access Network (TWAN) is interfaced with the EPC as a trusted non-3GPP access via the S2a interface to the P-GW. Support has been extended for WiFi-to-LTE handovers using Make and Break for the SAEGW service. Multi-PDN handovers are also supported as part of this feature.

Supported functionality includes:

- Initial Attach
- WiFi-to-LTE handover
- LTE-to-WiFi handover
- Multi-PDN handovers

Operators deploying StarOS release 20.0 on the SAEGW are now able to integrate Trusted WiFi network functionality using this feature.

GTP-based S2b Interface Support on the Standalone P-GW and SAEGW

Use of GTP-based S2b Interface Support on the Standalone P-GW and SAEGW requires that a valid license key be installed. Contact your Cisco account or support representative for information on how to obtain a license.

The S2b interface connects the standalone P-GW with the ePDG and the P-GW of the SAEGW with the ePDG. The UE tries to simultaneously connect to different APNs through different access networks only if the home network supports such simultaneous connectivity. The UE determines that the network supports such simultaneous connectivity over multiple accesses if the UE is provisioned with or has received per-APN inter-system routing policies. So the UE can have independent PDN connections via multiple access types. The access types supported are 4G and WiFi.

The S2b interface implementation on the P-GW and SAEGW supports the following:

- UE connecting to PDN via WiFi access
- UE multiple PDN connections
- Initial Attach
- LTE to WiFi Handoff
- WiFi to LTE Handoff



Note For more information on the S2a/S2b interface capability, refer to the *GTP-based S2b Interface Support on the P-GW and SAEGW* chapter in this guide.

GTP Throttling

Use of GTP and Diameter Interface Throttling requires that a valid license key be installed. Contact your Cisco account or support representative for information on how to obtain a license.

This feature will help control the rate of incoming/outgoing messages on P-GW/GGSN. This will help in ensuring P-GW/GGSN doesn't get overwhelmed by the GTP control plan messages. In addition, it will help in ensuring the P-GW/GGSN will not overwhelm the peer GTP-C peer with GTP Control plane messages.

This feature requires shaping/policing of GTP (v1 and v2) control messages over Gn/Gp and S5/S8 interfaces. Feature will cover overload protection of P-GW/GGSN nodes and other external nodes with which it communicates. Throttling would be done only for session level control messages. Path management messages would not be rate limited at all.

External node overload can happen in a scenario where P-GW/GGSN generates signaling requests at a higher rate than other nodes can handle. If the incoming message rate is higher than the configured message rate, extra messages will get silently dropped. Also the actual call setup rate can be lower than the msg-rate configured, which could be due to delays in setting up the session due to many reasons like slow peer nodes or overloaded sm. Also the drops done as part of this throttling are silent drops, hence if path failure is configured for non-echo messages, path failure can be observed.

For protecting external nodes from getting overloaded from P-GW/GGSN control signaling, a framework will be used to handle shaping/policing of outbound control messages to external interfaces.

Bypass Rate Limit Function

The Bypass Rate Limit Function is an enhancement to the existing GTP Throttling feature.

This enhancement requires no additional license. Existing licenses for the GTP-Throttling Feature (RLF License) and the VoLTE Prioritized Handling feature have been applied and used as follows:

- **RLF License:** The GTP-Throttling feature license has been enhanced to accommodate the message-types based RLF throttling bypass.
- **VoLTE Prioritized Handling Feature License:** This license has been enhanced to accommodate the emergency call, priority call, and apn-names based RLF throttling bypass.

The GTP Throttling feature helps control the rate of incoming/outgoing messages on P-GW/GGSN. It prevents the message flood from P-GW towards S-GW and MME. Currently, following outgoing messages are throttled by P-GW and GGSN using the RLF framework:

- Create Bearer Request (CBR)
- Delete Bearer Request (DBR)
- Update Bearer Request (UBR)
- NRUPC
- IPCA
- NRDPC

Once throttling is enabled for outgoing messages, all outgoing messages are throttled except the Create Bearer Request (CBR) message, which is piggybacked with Create Session Response message.

This feature has been enhanced to control the bypassing of some messages being throttled.

Operator can configure Overload Protection/RLF Throttling-override (Bypass RLF) on P-GW along with Overload Control feature at the egress side. In this scenario, the Overload Control based on peer's reduction metrics will take higher precedence and messages will be throttled based on Overload Control feature first.

If the message is passed to RLF throttling after Overload control feature processing then the Throttling override (Bypass RLF) will be applied after that according to the configuration. If the overload control feature is not configured and RLF throttling and Bypass RLF throttling is configured, then messages would be throttled based on RLF and throttling override (Bypass RLF) feature.

A new command option **throttling-override-policy** has been added to the existing CLI command **gtpc overload-protection egress rlf-template rlf-temp** which allows you to selectively by-pass throttling for a configured message type or for all messages in emergency call or priority call or call for the configured APN. A new CLI command mode **throttling-override-policy** has been also been introduced for Generic syntax for throttling override policy.



Important For more information on these commands, refer to the CLI Reference Guide.

HSS and PCRF Based P-CSCF Restoration Support

Use of P-CSCF Restoration requires that a valid license key be installed. Contact your Cisco Account or Support representative for information on how to obtain a license.

This feature enables support for P-CSCF restoration. The P-CSCF restoration procedures were standardized to minimize the time a UE is unreachable for terminating calls after a P-CSCF failure. In compliance with 3GPP standard Release 13, this feature includes the following P-CSCF restoration mechanisms:

- HSS-based P-CSCF Restoration for Trusted/Untrusted WLAN Access (S2a/S2b)
- PCRF-based P-CSCF Restoration for LTE (S5/S8) and Trusted/Untrusted WLAN Access (S2a/S2b)



Important For more information on this feature, refer to the *HSS and PCRF Based P-CSCF Restoration Support* chapter in this guide.

Inter-Chassis Session Recovery

Use of Interchassis Session Recovery requires that a valid license key be installed. Contact your local sales or support representative for information on how to obtain a license.

The ASR 5500 provides industry leading carrier class redundancy. The systems protects against all single points of failure (hardware and software) and attempts to recover to an operational state when multiple simultaneous failures occur.

The system provides several levels of system redundancy:

- Under normal N+1 packet processing card hardware redundancy, if a catastrophic packet processing card failure occurs all affected calls are migrated to the standby packet processing card if possible. Calls which cannot be migrated are gracefully terminated with proper call-termination signaling and accounting records are generated with statistics accurate to the last internal checkpoint
- If the Session Recovery feature is enabled, any total packet processing card failure will cause a packet processing card switchover and all established sessions for supported call-types are recovered without any loss of session.

Even though Cisco provides excellent intra-chassis redundancy with these two schemes, certain catastrophic failures which can cause total chassis outages, such as IP routing failures, line-cuts, loss of power, or physical destruction of the chassis, cannot be protected by this scheme. In such cases, the MME Inter-Chassis Session Recovery feature provides geographic redundancy between sites. This has the benefit of not only providing enhanced subscriber experience even during catastrophic outages, but can also protect other systems such as the RAN from subscriber re-activation storms.

The Interchassis Session Recovery feature allows for continuous call processing without interrupting subscriber services. This is accomplished through the use of redundant chassis. The chassis are configured as primary and backup with one being active and one in recovery mode. A checkpoint duration timer is used to control when subscriber data is sent from the active chassis to the inactive chassis. If the active chassis handling the call traffic goes out of service, the inactive chassis transitions to the active state and continues processing the call traffic without interrupting the subscriber session. The chassis determines which is active through a propriety TCP-based connection called a redundancy link. This link is used to exchange Hello messages between the primary and backup chassis and must be maintained for proper system operation.

• Interchassis Communication

Chassis configured to support Interchassis Session Recovery communicate using periodic Hello messages. These messages are sent by each chassis to notify the peer of its current state. The Hello message contains information about the chassis such as its configuration and priority. A dead interval is used to set a time limit for a Hello message to be received from the chassis' peer. If the standby chassis does not receive a Hello message from the active chassis within the dead interval, the standby chassis transitions to the active state. In situations where the redundancy link goes out of service, a priority scheme is used to determine which chassis processes the session. The following priority scheme is used:

- router identifier
- chassis priority
- SPIO MAC address

• Checkpoint Messages

Checkpoint messages are sent from the active chassis to the inactive chassis. Checkpoint messages are sent at specific intervals and contain all the information needed to recreate the sessions on the standby chassis, if that chassis were to become active. Once a session exceeds the checkpoint duration, checkpoint data is collected on the session. The checkpoint parameter determines the amount of time a session must be active before it is included in the checkpoint message.



Important

For more information on inter-chassis session recovery support, refer to the *Interchassis Session Recovery* chapter in the *System Administration Guide*.

IP Security (IPSec) Encryption

Use of Network Domain Security requires that a valid license key be installed. Contact your local sales or support representative for information on how to obtain a license.

IPSec encryption enables network domain security for all IP packet switched LTE-EPC networks in order to provide confidentiality, integrity, authentication, and anti-replay protection. These capabilities are insured through use of cryptographic techniques.

The Cisco P-GW supports IKEv1 and IPSec encryption using IPv4 addressing. IPSec enables the following two use cases:

- Encryption of S8 sessions and EPS bearers in roaming applications where the P-GW is located in a separate administrative domain from the S-GW.
- IPSec ESP security in accordance with 3GPP TS 33.210 is provided for S1 control plane, S1 bearer plane and S1 management plane traffic. Encryption of traffic over the S1 reference interface is desirable in cases where the EPC core operator leases radio capacity from a roaming partner's network.



Important For more information on IPSec support, refer to the *IP Security (IPSec) Reference*.

IPv6 Prefix Delegation from the RADIUS Server and the Local Pool

This feature adds support to obtain the DHCPv6 Prefix Delegation from the RADIUS server or a local pool configured on the GGSN/P-GW/SAEGW. Interface-ID allocation from RADIUS Server is also supported along with this feature.

A User Equipment (UE) or a Customer Premises Equipment (CPE) requests Prefix-Delegation. The P-GW or the GGSN then obtains this prefix from the RADIUS server or the local pool. P-GW and GGSN then advertise the prefix obtained by either RADIUS server or the local pool toward the UE client or the CPE.

This feature is divided into following three features:

- IPv6 Prefix Delegation from the RADIUS Server
- IPv6 Prefix Delegation from the Local Pool
- IPv6 Interface ID from the RADIUS Server



Important For more information on IPv6 Prefix Delegation, refer *IPv6 Prefix Delegation from the RADIUS Server and the Local Pool* chapter.

L2TP LAC Support

Use of L2TP LAC requires that a valid license key be installed. Contact your local sales or support representative for information on how to obtain a license.

The system configured as a Layer 2 Tunneling Protocol Access Concentrator (LAC) enables communication with L2TP Network Servers (LNSs) for the establishment of secure Virtual Private Network (VPN) tunnels between the operator and a subscriber's corporate or home network.

The use of L2TP in VPN networks is often used as it allows the corporation to have more control over authentication and IP address assignment. An operator may do a first level of authentication, however use PPP to exchange user name and password, and use IPCP to request an address. To support PPP negotiation between the P-GW and the corporation, an L2TP tunnel must be setup in the P-GW running a LAC service.

L2TP establishes L2TP control tunnels between LAC and LNS before tunneling the subscriber PPP connections as L2TP sessions. The LAC service is based on the same architecture as the P-GW and benefits from dynamic resource allocation and distributed message and data processing.

The LAC sessions can also be configured to be redundant, thereby mitigating any impact of hardware or software issues. Tunnel state is preserved by copying the information across processor cards.



Important For more information on this feature support, refer to the *L2TP Access Concentrator* chapter in this guide.

Lawful Intercept

The feature use license for Lawful Intercept on the P-GW is included in the P-GW session use license.

The Cisco Lawful Intercept feature is supported on the P-GW. Lawful Intercept is a licensed-enabled, standards-based feature that provides telecommunications service providers with a mechanism to assist law enforcement agencies in monitoring suspicious individuals for potential illegal activity. For additional information and documentation on the Lawful Intercept feature, contact your Cisco account representative.

Layer 2 Traffic Management (VLANs)

Use of Layer 2 Traffic Management requires that a valid license key be installed. Contact your Cisco sales or support representative for information on how to obtain a license.

Virtual LANs (VLANs) provide greater flexibility in the configuration and use of contexts and services.

VLANs are configured as "tags" on a per-port basis and allow more complex configurations to be implemented. The VLAN tag allows a single physical port to be bound to multiple logical interfaces that can be configured in different contexts; therefore, each Ethernet port can be viewed as containing many logical ports when VLAN tags are employed.



Important For more information on VLAN support, refer to the *VLANs* chapter in the *System Administration Guide*.

Local Policy Decision Engine

Use of the Local Policy Decision Engine requires that a valid license key be installed. Contact your local Cisco sales or support representative for information on how to obtain a license.

The Local Policy Engine is an event-driven rules engine that offers Gx-like QoS and policy controls to enable user or application entitlements. As the name suggests, it is designed to provide a subset of a PCRF in cases where an operator elects not to use a PCRF or scenarios where connections to an external PCRF are disrupted. Local policies are used to control different aspects of a session like QoS, data usage, subscription profiles, and server usage by means of locally defined policies. A maximum of 1,024 local policies can be provisioned on a P-GW system.

Local policies are triggered when certain events occur and the associated conditions are satisfied. For example, when a new call is initiated, the QoS to be applied for the call could be decided based on the IMSI, MSISDN, and APN.

Potential use cases for the Local Policy Decision Engine include:

- Disaster recovery data backup solution in the event of a loss of PCRF in a mobile core network.
- Dedicated bearer establishment for emergency voice calls.
- Network-initiated bearer establishment on LTE to non-3GPP inter-domain handovers.

MPLS Forwarding with LDP

Use of MPLS requires that a valid license key be installed. Contact your local Cisco sales or support representative for information on how to obtain a license.

Multi Protocol Label Switching (MPLS) is an operating scheme or a mechanism that is used to speed up the flow of traffic on a network by making better use of available network paths. It works with the routing protocols like BGP and OSPF, and therefore it is not a routing protocol.

MPLS generates a fixed-length label to attach or bind with the IP packet's header to control the flow and destination of data. The binding of the labels to the IP packets is done by the label distribution protocol (LDP). All the packets in a forwarding equivalence class (FEC) are forwarded by a label-switching router (LSR), which is also called an MPLS node. The LSR uses the LDP in order to signal its forwarding neighbors and distribute its labels for establishing a label switching path (LSP).

In order to support the increasing number of corporate APNs, which have a number of different addressing models and requirements, MPLS is deployed to fulfill at least the following two requirements:

- The corporate APN traffic must remain segregated from other APNs for security reasons.
- Overlapping of IP addresses in different APNs.

When deployed, the MPLS backbone automatically negotiates routes using the labels binded with the IP packets. Cisco P-GW as an LSR learns the default route from the connected provider edge (PE), while the PE populates its routing table with the routes provided by the P-GW.

NEMO Service Supported

Use of NEMO requires that a valid license key be installed. Contact your local sales or support representative for information on how to obtain a license.

The P-GW may be configured to enable or disable Network Mobility (NEMO) service.

When enabled, the system includes NEMO support for a Mobile IPv4 Network Mobility (NEMO-HA) on the P-GW platform to terminate Mobile IPv4 based NEMO connections from Mobile Routers (MRs) that attach to an Enterprise PDN. The NEMO functionality allows bi-directional communication that is application-agnostic between users behind the MR and users or resources on Fixed Network sites.

The same NEMO4G-HA service and its bound Loopback IP address supports NEMO connections whose underlying PDN connection comes through GTP S5 (4G access) or PMIPv6 S2a (eHRPD access).



Important For more information on NEMO support, refer to the *Network Mobility (NEMO)* chapter in this guide.

NEMO Support in GGSN

Use of Dynamic Network Mobile Routing (NEMO) for GGSN requires that a valid license key be installed. Contact your Cisco account or support representative for information on how to obtain a license.

This feature now supports standards-based NEMO feature on GGSN, which allows operators to support Enterprise VPN service with the advantage of faster deployment and flexible bandwidth arrangement for customers.

NEMO (NEtwork MObility) provides wireless connectivity between enterprise core network and remote sites over 3G/4G network. The wireless connection can be used as either primary link or backup link. All the hosts in the remote site can directly communicate with hosts in the core network without using NAT.

Enterprise VPN service is one of the main use case for this feature. Fast deployment and flexible bandwidth arrangement for customers are some of the advantages of this service. Customers include banks, financial institutions, multi-sited enterprises, city public safety departments, transportation fleet, etc.

NEMO is supported for subscribers roaming out on 3G (UMTS/GERAN) networks.

Network Provided Location Information for IMS

Use of NPLI requires that a valid license key be installed. Contact your Cisco account or support representative for information on how to obtain a license.

This feature enables the P-GW to provide the required access network information to the PCRF within the 3GPP-User-Location-Info AVP, User-Location-Info-Time AVP (if available), and/or 3GPP-MS-TimeZone AVP as requested by the PCRF. The P-GW will also provide the ACCESS_NETWORK_INFO_REPORT event trigger within Event-Trigger AVP.

During bearer deactivation or UE detach procedure, the P-GW will provide the access network information to the PCRF within the 3GPP-User-Location-Info AVP and information on when the UE was last known to be in that location within User-Location-Info-Time AVP. If the PCRF requested User location info as part of the Required-Access-Info AVP and it is not available in the P-GW, then the P-GW will provide the serving PLMN identifier within the 3GPP-SGSN-MCC-MNC AVP.

Previously, the P-GW notified ULI/MS-TimeZone/PLMN-ID to ECS/IMSA/PCRF only when their value changed. With this feature, the P-GW receives NetLoc indication in the rules sent by ECS regardless of whether the values changed and it sends this to the ECS/IMSA/PCRF. If the P-GW receives NetLoc as '1', then it will inform MS-Timezone. If the P-GW receives NetLoc as '0', then it will inform ULI and ULI Timestamp. If ULI is not available in that case, then the PLMN-ID is sent. If NetLoc indication is received for an update, then the P-GW will indicate this information to the access side in the UBReq using the RetLoc Indication flag.

This is required for VoLTE and aids in charging and LI functionality in IMS domain. This feature allows EPC core to support an efficient way of reporting ULI and Time-Zone information of the subscriber to the IMS core network.

New Call Policy for Stale Sessions

Use of new call policy for stale sessions requires that a valid license key be installed. Contact your Cisco account or support representative for information on how to obtain a license.

If the newcall policy is set to **reject release-existing-session** and there are pre-existing sessions for the IMSI/IMEI received in Create Session Req, they will be deleted. This allows for no hung sessions on node with newcall policy reject release configured. When GGSN/P-GW/SAEGW/S-GW releases the existing call,

it follows a proper release process of sending Accounting Stop, sending CCR-T to PCRF/OCS, and generating CDR(s).

Non-standard QCI Support

Use of non-standard QCIs require that a valid license key be installed. Contact your Cisco account or support representative for information on how to obtain a license.

Usually, only standards-based QCI values of 1 through 9 are supported on GGSN/P-GW/SAEGW/S-GW/ePDG. A special license, however, allows non-standard QCIs (128-254) to be used on P-GW/GGSN (not standalone GGSN).

QCI values 1 through 9 are defined in *3GPP Specification TS 23.203 "Policy and charging control architecture"*

From 3GPP Release 8 onwards, operator-specific/non-standard QCIs can be supported and carriers can define QCI 128-254. As per *3GPP Specification TS 29.212 "Policy and Charging Control over Gx reference point,"* QCI values 0 and 10 to 255 are defined as follows:

- 0: Reserved
- 10-127: Reserved
- 128-254: Operator-specific/Non-standard QCI
- 255: Reserved

Unique operator-specific QCIs (128-254) can be used to differentiate between various services/applications carriers provide to the end users in their network.

The **operator-defined-qci** command in the QCI-QoS Mapping Configuration Mode configures the non-standard QCIs in P-GW so that calls can be accepted when non-standard QCI values are received from UE or PCRF. Unique DSCP parameters (uplink and downlink) and GBR or Non-GBR can also be configured. Non-standard QCIs can only be supported with S5/S8/S2a/S2b interfaces; the Gn interface is not supported. As non-standard QCIs are not supported in GGSN, **pre-rel8-qos-mapping** is used as a reference for mapping the non-standard QCI values to pre-rel8 QoS values during 3G calls or GnGp handovers.



Important For more information on this command, refer to the *CLI Reference Guide*.

Paging Policy Differentiation

This feature requires that a valid license key be installed. Contact your Cisco Account or Support representative for information on how to obtain a license.

S-GW/P-GW provide configuration control to change the DSCP value of the user-datagram packet and outer IP packet (GTP-U tunnel IP header). DSCP marking is done at various levels depending on the configuration. When the Paging Policy Differentiation (PPD) feature is enabled, however, the user-datagram packet DSCP (tunneled IP packet) marking does not change.

Currently, standards specify QCI to DSCP marking of outer GTP-U header only. All configurations present at ECS, P-GW, and S-GW to change the user-datagram packet DSCP value are non-standard. The standards-based PPD feature dictates that P-CSCF or similar Gi entity marks the DSCP of user-datagram packet. This user-datagram packet DSCP value is sent in DDN message by S-GW to MME/S4-SGSN. MME/S4-SGSN uses this DSCP value to give paging priority.



Important P-GW and S-GW should apply the PPD feature for both Default and Dedicated bearers. As per the specifications, P-GW transparently passes the user-datagram packet towards S-GW. This means, if PPD feature is enabled, operator can't apply different behavior for Default and Dedicated bearers.



Important For more information on paging policy differentiation, refer to the *Paging Policy Differentiation* chapter in this guide.

Per QCI Packet Drop Counters and ARP Granularity for QCI Level Counters

Support for QCI and ARP Visibility

As of StarOS release 20.2, the software has been enhanced to support the viewing of QoS statistics on a Quality of Service Class Index (QCI) and Allocation and Retention Priority (ARP) basis.

ARP is a 3GPP mechanism for dropping or downgrading lower-priority bearers in situations where the network becomes congested. The network looks at the ARP when determining if new dedicated bearers can be established through the radio base station. QCI is an operator provisioned value that controls bearer level packet forwarding treatments.

This enhancement enables operators to monitor QoS statistics that identify multiple services running with the same QCI value. In addition, packet drop counters have been introduced to provide the specific reason the Enhanced Charging Service (ECS) dropped a packet. The packet drop counters provide output on a per ARP basis. This provides additional information that operators can use to troubleshoot and identify network issues that may be affecting service.



Important For the ARP value only the priority level value in the Allocation/Retention Priority (ARP) Information Element (IE) is considered. Pre-emption Vulnerability (PVI) and Pre-emption Capability (PCI) flags in the ARP IE are not considered.

The existing **show apn statistics name** *apn-name* and **show apn statistics Exec Mode** CLI commands have been enhanced. The output of these commands now provides visibility for QoS statistics on a QCI/ARP basis.



Important For more detailed information, refer to the *Extended QCI Options* chapter in this guide.

Licensing

ARP Granularity for QCI Level Counters is a license-controlled feature. Per QCI Packet Drop Counters functionality does not require a license. Contact your Cisco account or support representative for licensing details.

Piggyback Support on S2b Interface

This feature supports piggybacking of "Create Session Response" and "Create Bearer Request" messages on ePDG and P-GW over the S2b interface. If piggybacking flag is set by the ePDG in the Create Session Request, P-GW can now send Create Session Response and Create Bearer Request together to the ePDG and eliminate the possibility of reordering of these messages.

R12 Load and Overload Support

Use of R12 Load and Overload Support requires that a valid license key be installed. Contact your Cisco account or support representative for information on how to obtain a license.

GTP-C Load Control feature is an optional feature which allows a GTP control plane node to send its Load Information to a peer GTP control plane node which the receiving GTP control plane peer node uses to augment existing GW selection procedure for the P-GW and S-GW. Load Information reflects the operating status of the resources of the originating GTP control plane node.

Nodes using GTP control plane signaling may support communication of Overload control Information in order to mitigate overload situation for the overloaded node through actions taken by the peer node(s). This feature is supported over S4, S11, S5 and S8 interfaces via the GTPv2 control plane protocol.

A GTP-C node is considered to be in overload when it is operating over its nominal capacity resulting in diminished performance (including impacts to handling of incoming and outgoing traffic). Overload control Information reflects an indication of when the originating node has reached such a situation. This information, when transmitted between GTP-C nodes may be used to reduce and/or throttle the amount of GTP-C signaling traffic between these nodes. As such, the Overload control Information provides guidance to the receiving node to decide actions, which leads to mitigation towards the sender of the information.

In brief, load control and overload control can be described in this manner:

- Load control enables a GTP-C entity (for example, an S-GW/P-GW) to send its load information to a GTP-C peer (e.g. an MME/SGSN, ePDG, TWAN) to adaptively balance the session load across entities supporting the same function (for example, an S-GW cluster) according to their effective load. The load information reflects the operating status of the resources of the GTP-C entity.
- Overload control enables a GTP-C entity becoming or being overloaded to gracefully reduce its incoming signaling load by instructing its GTP-C peers to reduce sending traffic according to its available signaling capacity to successfully process the traffic. A GTP-C entity is in overload when it operates over its signaling capacity, which results in diminished performance (including impacts to handling of incoming and outgoing traffic).

A maximum of 64 different load and overload profiles can be configured.



Important For more information on this feature, refer to the *GTP-C Load and Overload Control Support on the P-GW, SAEGW, and S-GW* chapter in this guide.

Operation

The node periodically fetches various parameters (for example, License-Session-Utilization, System-CPU-Utilization and System-Memory-Utilization), which are required for Node level load control information. The node then calculates the load control information itself either based on the weighted factor provided by the user or using the default weighted factor.

Node level load control information is calculated every 30 seconds. The resource manager calculates the system-CPU-utilization and System-Memory-Utilization at a systems level.

For each configured service, load control information can be different. This can be achieved by providing a weightage to the number of active session counts per service license, for example, $((\text{number of active sessions per service} / \text{max session allowed for the service license}) * 100)$.

The node's resource manager calculates the system-CPU-utilization and System-Memory-Utilization at a systems level by averaging CPU and Memory usage for all cards and which might be different from that calculated at the individual card level.

Session Recovery Support

The feature use license for Session Recovery on the P-GW is included in the P-GW session use license.

Session recovery provides seamless failover and reconstruction of subscriber session information in the event of a hardware or software fault within the system preventing a fully connected user session from being disconnected.

In the telecommunications industry, over 90 percent of all equipment failures are software-related. With robust hardware failover and redundancy protection, any card-level hardware failures on the system can quickly be corrected. However, software failures can occur for numerous reasons, many times without prior indication. StarOS Release 9.0 adds the ability to support stateful intra-chassis session recovery for P-GW sessions.

When session recovery occurs, the system reconstructs the following subscriber information:

- Data and control state information required to maintain correct call behavior
- Subscriber data statistics that are required to ensure that accounting information is maintained
- A best-effort attempt to recover various timer values such as call duration, absolute time, and others

Session recovery is also useful for in-service software patch upgrade activities. If session recovery is enabled during the software patch upgrade, it helps to preserve existing sessions on the active packet processing cards during the upgrade process.



Important For more information on session recovery support, refer to the *Session Recovery* chapter in the *System Administration Guide*.

S-GW Paging Enhancements

Use of S-GW Paging requires that a valid license key be installed. Contact your Cisco account representative for information on how to obtain a license.

S-GW Paging includes the following scenarios:

Scenario 1: S-GW sends a DDN message to the MME/S4-SGSN nodes. MME/S4-SGSN responds to the S-GW with a DDN Ack message. While waiting for the DDN Ack message from the MME/S4-SGSN, if the S-GW receives a high priority downlink data, it does not resend a DDN to the MME/S4-SGSN.

Scenario 2: If a DDN is sent to an MME/S4-SGSN and TAU/RAU MBR is received from another MME/S4-SGSN, S-GW does not send DDN.

Scenario 3: DDN is sent to an MME/S4-SGSN and DDN Ack with Cause #110 is received. DDN Ack with cause 110 is treated as DDN failure and standard DDN failure action procedure is initiated.

To handle these scenarios, the following two enhancements have been added to the DDN functionality:

- High Priority DDN at S-GW
- MBR-DDN Collision Handling

These enhancements support the following:

- Higher priority DDN on S-GW and SAEGW, which helps MME/S4-SGSN to prioritize paging.
- Enhanced paging KPI and VoLTE services.
- DDN message and mobility procedure so that DDN is not lost.
- MBR guard timer, which is started when DDN Ack with temporary HO is received. A new CLI command **ddn temp-ho-rejection mbr-guard-timer** has been introduced to enable the guard timer to wait for MBR once the DDN Ack with cause #110 (Temporary Handover In Progress) is received.
- TAU/RAU with control node change triggered DDNs.

In addition to the above functionality, to be compliant with 3GPP standards, support has been enhanced for Downlink Data Notification message and Mobility procedures. As a result, DDN message and downlink data which triggers DDN is not lost. This helps improve paging KPI and VoLTE success rates in scenarios where DDN is initiated because of SIP invite data.



Important For more information on this functionality, refer to the *S-GW Paging Enhancements* chapter in this guide.

Smartphone Tethering Detection Support

Use of Smartphone Tethering Detection requires that a valid license key be installed. Contact your local Sales or Support representative for information on how to obtain a license.

On the P-GW, using the inline heuristic detection mechanism, it is now possible to detect and differentiate between the traffic from the mobile device and a tethered device connected to the mobile device.

Traffic Policing

Use of Per-Subscriber Traffic Policing requires that a valid license key be installed. Contact your local Sales or Support representative for information on how to obtain a license.

Traffic policing allows you to manage bandwidth usage on the network and limit bandwidth allowances to subscribers.

Traffic policing enables the configuring and enforcing of bandwidth limitations on individual subscribers and/or APNs of a particular traffic class in 3GPP/3GPP2 service.

Bandwidth enforcement is configured and enforced independently on the downlink and the uplink directions.

A Token Bucket Algorithm (a modified trTCM) [RFC2698] is used to implement the Traffic-Policing feature. The algorithm used measures the following criteria when determining how to mark a packet:

- **Committed Data Rate (CDR):** The guaranteed rate (in bits per second) at which packets can be transmitted/received for the subscriber during the sampling interval.
- **Peak Data Rate (PDR):** The maximum rate (in bits per second) that subscriber packets can be transmitted/received for the subscriber during the sampling interval.
- **Burst-size:** The maximum number of bytes that can be transmitted/received for the subscriber during the sampling interval for both committed (CBS) and peak (PBS) rate conditions. This represents the maximum number of tokens that can be placed in the subscriber's "bucket". Note that the committed burst size (CBS) equals the peak burst size (PBS) for each subscriber.

The system can be configured to take any of the following actions on packets that are determined to be in excess or in violation:

- **Drop:** The offending packet is discarded.
- **Transmit:** The offending packet is passed.
- **Lower the IP Precedence:** The packet's ToS bit is set to "0", thus downgrading it to Best Effort, prior to passing the packet. Note that if the packet's ToS bit was already set to "0", this action is equivalent to "Transmit".



Important For more information on traffic policing, refer to the *Traffic Policing and Shaping* chapter in this guide.

Traffic Shaping

Traffic Shaping is a rate limiting method similar to Traffic Policing, but provides a buffer facility for packets exceeding the configured limit. Once packets exceed the data-rate, the packet is queued inside the buffer to be delivered at a later time.

The bandwidth enforcement can be done in the downlink and the uplink direction independently. If there is no more buffer space available for subscriber data, the system can be configured to either drop the packets or retain them for the next scheduled traffic session.

Traffic will be shaped to the configured APN-AMBR value. Previously, data carried on non-GBR bearers was policed at the configured APN-AMBR rate. APN-AMBR policing dropped the data that did not match the configured APN-AMBR. With APN-AMBR traffic shaping, non-GBR data that does not match the configured APN-AMBR rate will be buffered. When enough memory tokens are available, the data will be transmitted. In addition, operators still have the option to allow operators to drop or transmit the data when the buffer limit is reached.



Important For more information on traffic shaping, refer to the *Traffic Policing and Shaping* chapter in this guide.

UBR Suppression Feature

The Update Bearer Request (UBR) Suppression feature is a license controlled feature. Please contact your Cisco account or service representative for more information.

As the bit rate is expressed in bps on Gx and kbps on GTP, the P-GW does a round-off to convert a Gx request into a GTP request. When the P-GW receives RAR from PCRF with minimal bit rate changes (in bps), a UBR is sent, even if the same QoS (in Kbps) is already set for the bearer. The UBR suppression feature enables the P-GW to suppress such a UBR where there is no update for any of the bearer parameters.

A new CLI command, **suppress-ubr no-bitrate-change**, has been added to the P-GW Service Configuration Mode to enable UBR suppression. Once the CLI is configured, P-GW suppresses the UBR if the bit rate is the same after the round-off.

When UBR has multiple bearer contexts, the bearer context for which the bit rate change is less than 1 kbps after round-off is suppressed. If other parameters, such as QCI, ARP, and TFT, that might trigger UBR are changed and there is no change in bit rates after round-off, then UBR is not suppressed. Suppression of UBR is applicable for UBR triggered by CCA-I, RAR, and Modify Bearer Command.

To summarize, if the license is enabled and the CLI command is configured for UBR suppression, then UBR is suppressed if bit rates in kbps are the same after round-off and all other parameters, such as QCI, ARP, and TFT, that might trigger UBR are also unchanged.

User Location Information Reporting

Use of User Location Information (ULI) Reporting requires that a valid license key be installed. Contact your local sales or support representative for information on how to obtain a license.

ULI Reporting allows the eNodeB to report the location of a UE to the MME, when requested by a P-GW.

The following procedures are used over the S1-MME interface to initiate and stop location reporting between the MME and eNodeB:

- **Location Reporting Control:** The purpose of Location Reporting Control procedure is to allow the MME to request that the eNodeB report where the UE is currently located. This procedure uses UE-associated signaling.
- **Location Report Failure Indication:** The Location Report Failure Indication procedure is initiated by an eNodeB in order to inform the MME that a Location Reporting Control procedure has failed. This procedure uses UE-associated signaling.
- **Location Report:** The purpose of Location Report procedure is to provide the UE's current location to the MME. This procedure uses UE-associated signaling.

The start/stop trigger for location reporting for a UE is reported to the MME by the S-GW over the S11 interface. The Change Reporting Action (CRA) Information Element (IE) is used for this purpose. The MME updates the location to the S-GW using the User Location Information (ULI) IE.

The following S11 messages are used to transfer CRA and ULI information between the MME and S-GW:

- **Create Session Request:** The ULI IE is included for E-UTRAN Initial Attach and UE-requested PDN Connectivity procedures. It includes ECGI and TAI. The MME includes the ULI IE for TAU/ X2-Handover procedure if the P-GW has requested location information change reporting and the MME support location information change reporting. The S-GW includes the ULI IE on S5/S8 exchanges if it receives the ULI from the MME. If the MME supports change reporting, it sets the corresponding indication flag in the Create Session Request message.
- **Create Session Response:** The CRA IE in the Create Session Response message can be populated by the S-GW to indicate the type of reporting required.

- **Create Bearer Request:** The CRA IE is included with the appropriate Action field if the Location Change Reporting mechanism is to be started or stopped for the subscriber in the MME.
- **Modify Bearer Request:** The MME includes the ULI IE for TAU/Handover procedures and UE-initiated Service Request procedures if the P-GW has requested location information change reporting and the MME supports location information change reporting. The S-GW includes this IE on S5/S8 exchanges if it receives the ULI from the MME.
- **Modify Bearer Response:** The CRA IE is included with the appropriate Action field if the Location Change Reporting mechanism is to be started or stopped for the subscriber in the MME.
- **Delete Session Request:** The MME includes the ULI IE for the Detach procedure if the P-GW has requested location information change reporting and MME supports location information change reporting. The S-GW includes this IE on S5/S8 exchanges if it receives the ULI from the MME.
- **Update Bearer Request:** The CRA IE is included with the appropriate Action field if the Location Change Reporting mechanism is to be started or stopped for the subscriber in the MME.
- **Change Notification Request:** If no existing procedure is running for a UE, a Change Notification Request is sent upon receipt of an S1-AP location report message. If an existing procedure is running, one of the following messages reports the ULI:
 - Create Session Request
 - Create Bearer Response
 - Modify Bearer Request
 - Update Bearer Response
 - Delete Bearer Response
 - Delete Session Request

If an existing Change Notification Request is pending, it is aborted and a new one is sent.



Important

Information on configuring User Location Information (ULI) Reporting support is located in the *Configuring Optional Features on the MME* section of the *Mobility Management Entity Configuration* chapter in the *Mobility Management Entity Administration Guide*.

3GPP ULI Reporting Support Enhanced

This feature enhancement covers ULI related gaps in P-GW and GGSN as per 3GPP standards.

Feature Change

This feature enhancement covers ULI related gaps in P-GW and GGSN as per 3GPP standards.

S4SGSN reports ULI to the P-GW through S-GW. P-GW determines the changes in the ULI with previously received ULI. If any change is detected and same change has been requested by the PCRF as an event trigger then the ULI is reported to the PCRF.

SGSN reports ULI to the GGSN. GGSN determines the changes in the ULI with previously received ULI. If any change is detected and same change has been requested by the PCRF as an event trigger, then the ULI is

reported to the PCRF. Support has also been added to detect the change in RAI received as part of the ULI field at GGSN.

Following table summarizes the Change Reporting Action (CRA) values based on Event Triggers received from the PCRF, which the P-GW communicates with S4 SGSN.

Event Trigger From PCRF	CRA Sent to S4 SGSN
USER_LOCATION_CHANGE (13)	Start Reporting CGI/SAI and RAI (5)
RAI_CHANGE (12)	Start Reporting RAI (2)
USER_LOCATION_CHANGE + RAI_CHANGE	Start Reporting CGI/SAI and RAI (5)

Following table summarizes the MS Info Change Reporting Action values based on Event Triggers received from the PCRF which GGSN communicates to SGSN.

Event Trigger from PCRF	MS Info Change Reporting Action towards SGSN
USER_LOCATION_CHANGE (13)	Start Reporting CGI/SAI (1)
RAI_CHANGE (12)	Start Reporting RAI (2)
BOTH (12,13)	Start Reporting CGI/SAI (1)

P-GW/GGSN reports the CRA/MS Info Change Reporting Action immediately on receiving the Event Triggers without waiting for other events like APN/AMBR update or QoS update.

Behavior Change

Previous of Change Reporting Action: Following table illustrates the old and new behavior of Change Reporting Action with respect to the Event Triggers received from PCRF, when the Access Node is S4SGSN.

Event Trigger From PCRF	CRA Sent to S4SGSN	CRA Sent to S4SGSN
ULI_CHANGE(13)	6 (START_REPORTING_TAI_ECGI)	5 (START_REPORTING_CGI_RAI)
RAI_CHANGE(12)	No CRA Sent	2 (START_REPORTING_RAI)
BOTH (12,13)	6 (START_REPORTING_TAI_ECGI)	5 (START_REPORTING_CGI_RAI)

Behavior of MS Info Change Reporting Action: Following table illustrates the old and new behavior of MS Info CRA with respect to the Event Triggers received from PCRF, when the Access Node is SGSN.

Event Trigger From PCRF	CRA Sent to SGSN	CRA Sent to SGSN
ULI_CHANGE(13)	1 (START_REPORTING_CGI/SAI)	1 (START_REPORTING_CGI/SAI)
RAI_CHANGE(12)	No CRA Sent	2 (START_REPORTING_RAI)
BOTH (12,13)	1 (START_REPORTING_CGI/SAI)	1 (START_REPORTING_CGI/SAI)

Limitations

1. In GGSN, when a new ULI is received in the Network Request Updated PDP Context (NRUPC) Response, it is not reported to the PCRF.
2. In GGSN, when a dedicated bearer is deleted or call is dropped, ULI change is not detected.

How the Serving Gateway Works

This section provides information on the function of the S-GW in an EPC E-UTRAN network and presents call procedure flows for different stages of session setup and disconnect.

The S-GW supports the following network flows:

- [GTP Serving Gateway Call/Session Procedures in an LTE-SAE Network, on page 134](#)

GTP Serving Gateway Call/Session Procedures in an LTE-SAE Network

The following topics and procedure flows are included:

- [Subscriber-initiated Attach \(initial\), on page 134](#)
- [Subscriber-initiated Detach, on page 137](#)

Subscriber-initiated Attach (initial)

This section describes the procedure of an initial attach to the EPC network by a subscriber.

Figure 35: Subscriber-initiated Attach (initial) Call Flow

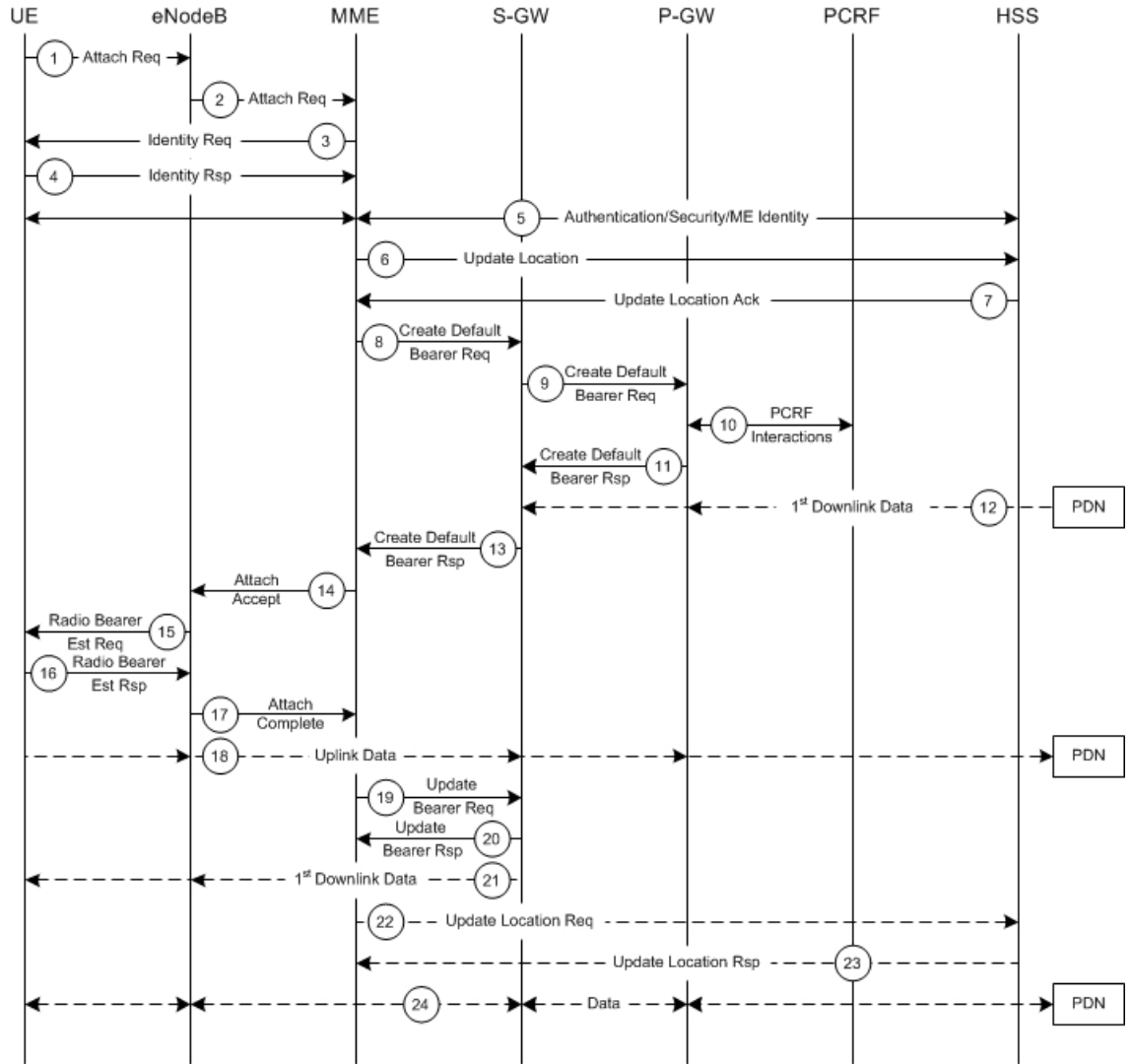

335262

Table 12: Subscriber-initiated Attach (initial) Call Flow Description

Step	Description
1	The UE initiates the Attach procedure by the transmission of an Attach Request (IMSI or old GUTI, last visited TAI (if available), UE Network Capability, PDN Address Allocation, Protocol Configuration Options, Attach Type) message together with an indication of the Selected Network to the eNodeB. IMSI is included if the UE does not have a valid GUTI available. If the UE has a valid GUTI, it is included.
2	The eNodeB derives the MME from the GUTI and from the indicated Selected Network. If that MME is not associated with the eNodeB, the eNodeB selects an MME using an MME selection function. The eNodeB forwards the Attach Request message to the new MME contained in a S1-MME control message (Initial UE message) together with the Selected Network and an indication of the E-UTRAN Area identity, a globally unique E-UTRAN ID of the cell from where it received the message to the new MME.

Step	Description
3	If the UE is unknown in the MME, the MME sends an Identity Request to the UE to request the IMSI.
4	The UE responds with Identity Response (IMSI).
5	If no UE context for the UE exists anywhere in the network, authentication is mandatory. Otherwise this step is optional. However, at least integrity checking is started and the ME Identity is retrieved from the UE at Initial Attach. The authentication functions, if performed this step, involves AKA authentication and establishment of a NAS level security association with the UE in order to protect further NAS protocol messages.
6	The MME sends an Update Location (MME Identity, IMSI, ME Identity) to the HSS.
7	The HSS acknowledges the Update Location message by sending an Update Location Ack to the MME. This message also contains the Insert Subscriber Data (IMSI, Subscription Data) Request. The Subscription Data contains the list of all APNs that the UE is permitted to access, an indication about which of those APNs is the Default APN, and the EPS subscribed QoS profile for each permitted APN. If the Update Location is rejected by the HSS, the MME rejects the Attach Request from the UE with an appropriate cause.
8	The MME selects an S-GW using the Serving GW selection function and allocates an EPS Bearer Identity for the Default Bearer associated with the UE. If the PDN subscription context contains no P-GW address the MME selects a P-GW as described in clause PDN GW selection function. Then it sends a Create Default Bearer Request (IMSI, MME Context ID, APN, RAT type, Default Bearer QoS, PDN Address Allocation, AMBR, EPS Bearer Identity, Protocol Configuration Options, ME Identity, User Location Information) message to the selected S-GW.
9	The S-GW creates a new entry in its EPS Bearer table and sends a Create Default Bearer Request (IMSI, APN, S-GW Address for the user plane, S-GW TEID of the user plane, S-GW TEID of the control plane, RAT type, Default Bearer QoS, PDN Address Allocation, AMBR, EPS Bearer Identity, Protocol Configuration Options, ME Identity, User Location Information) message to the P-GW.
10	If dynamic PCC is deployed, the P-GW interacts with the PCRF to get the default PCC rules for the UE. The IMSI, UE IP address, User Location Information, RAT type, AMBR are provided to the PCRF by the P-GW if received by the previous message.
11	The P-GW returns a Create Default Bearer Response (P-GW Address for the user plane, P-GW TEID of the user plane, P-GW TEID of the control plane, PDN Address Information, EPS Bearer Identity, Protocol Configuration Options) message to the S-GW. PDN Address Information is included if the P-GW allocated a PDN address Based on PDN Address Allocation received in the Create Default Bearer Request. PDN Address Information contains an IPv4 address for IPv4 and/or an IPv6 prefix and an Interface Identifier for IPv6. The P-GW takes into account the UE IP version capability indicated in the PDN Address Allocation and the policies of operator when the P-GW allocates the PDN Address Information. Whether the IP address is negotiated by the UE after completion of the Attach procedure, this is indicated in the Create Default Bearer Response.
12	The Downlink (DL) Data can start flowing towards S-GW. The S-GW buffers the data.
13	The S-GW returns a Create Default Bearer Response (PDN Address Information, S-GW address for User Plane, S-GW TEID for User Plane, S-GW Context ID, EPS Bearer Identity, Protocol Configuration Options) message to the new MME. PDN Address Information is included if it was provided by the P-GW.
14	The new MME sends an Attach Accept (APN, GUTI, PDN Address Information, TAI List, EPS Bearer Identity, Session Management Configuration IE, Protocol Configuration Options) message to the eNodeB.
15	The eNodeB sends Radio Bearer Establishment Request including the EPS Radio Bearer Identity to the UE. The Attach Accept message is also sent along to the UE.

Step	Description
16	The UE sends the Radio Bearer Establishment Response to the eNodeB. In this message, the Attach Complete message (EPS Bearer Identity) is included.
17	The eNodeB forwards the Attach Complete (EPS Bearer Identity) message to the MME.
18	The Attach is complete and UE sends data over the default bearer. At this time the UE can send uplink packets towards the eNodeB which are then tunneled to the S-GW and P-GW.
19	The MME sends an Update Bearer Request (eNodeB address, eNodeB TEID) message to the S-GW.
20	The S-GW acknowledges by sending Update Bearer Response (EPS Bearer Identity) message to the MME.
21	The S-GW sends its buffered downlink packets.
22	After the MME receives Update Bearer Response (EPS Bearer Identity) message, if an EPS bearer was established and the subscription data indicates that the user is allowed to perform handover to non-3GPP accesses, and if the MME selected a P-GW that is different from the P-GW address which was indicated by the HSS in the PDN subscription context, the MME sends an Update Location Request including the APN and P-GW address to the HSS for mobility with non-3GPP accesses.
23	The HSS stores the APN and P-GW address pair and sends an Update Location Response to the MME.
24	Bidirectional data is passed between the UE and PDN.

Subscriber-initiated Detach

This section describes the procedure of detachment from the EPC network by a subscriber.

Figure 36: Subscriber-initiated Detach Call Flow

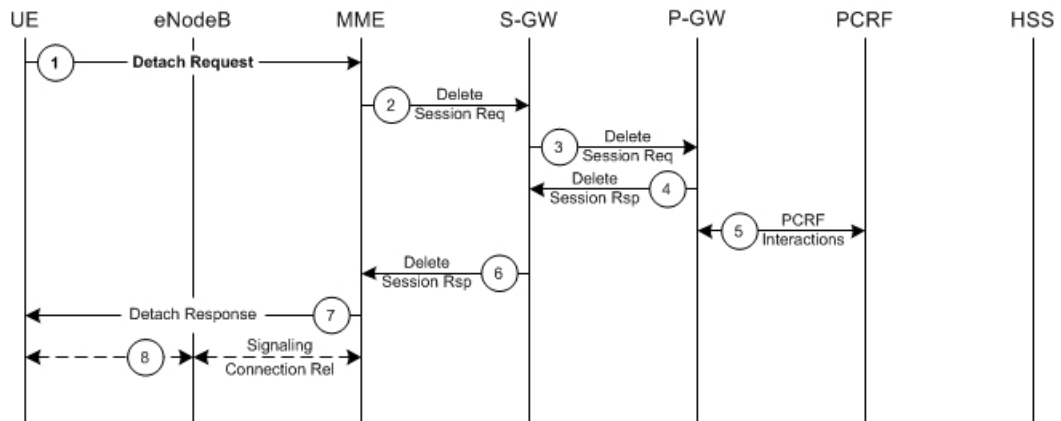

335263

Table 13: Subscriber-initiated Detach Call Flow Description

Step	Description
1	The UE sends NAS message Detach Request (GUTI, Switch Off) to the MME. Switch Off indicates whether detach is due to a switch off situation or not.
2	The active EPS Bearers in the S-GW regarding this particular UE are deactivated by the MME sending a Delete Bearer Request (TEID) message to the S-GW.

Step	Description
3	The S-GW sends a Delete Bearer Request (TEID) message to the P-GW.
4	The P-GW acknowledges with a Delete Bearer Response (TEID) message.
5	The P-GW may interact with the PCRF to indicate to the PCRF that EPS Bearer is released if PCRF is applied in the network.
6	The S-GW acknowledges with a Delete Bearer Response (TEID) message.
7	If Switch Off indicates that the detach is not due to a switch off situation, the MME sends a Detach Accept message to the UE.
8	The MME releases the S1-MME signaling connection for the UE by sending an S1 Release command to the eNodeB with Cause = Detach.

How the PDN Gateway Works

This section provides information on the function of the P-GW in an EPC E-UTRAN network and presents call procedure flows for different stages of session setup and disconnect.

The P-GW supports the following network flows:

- [PMIPv6 PDN Gateway Call/Session Procedures in an eHRPD Network, on page 138](#)
- [GTP PDN Gateway Call/Session Procedures in an LTE-SAE Network, on page 144](#)

PMIPv6 PDN Gateway Call/Session Procedures in an eHRPD Network

The following topics and procedure flows are included:

- [Initial Attach with IPv6/IPv4 Access, on page 138](#)
- [PMIPv6 Lifetime Extension without Handover, on page 140](#)
- [PDN Connection Release Initiated by UE, on page 141](#)
- [PDN Connection Release Initiated by HSGW, on page 142](#)
- [PDN Connection Release Initiated by P-GW, on page 143](#)

Initial Attach with IPv6/IPv4 Access

This section describes the procedure of initial attach and session establishment for a subscriber (UE).

Figure 37: Initial Attach with IPv6/IPv4 Access Call Flow

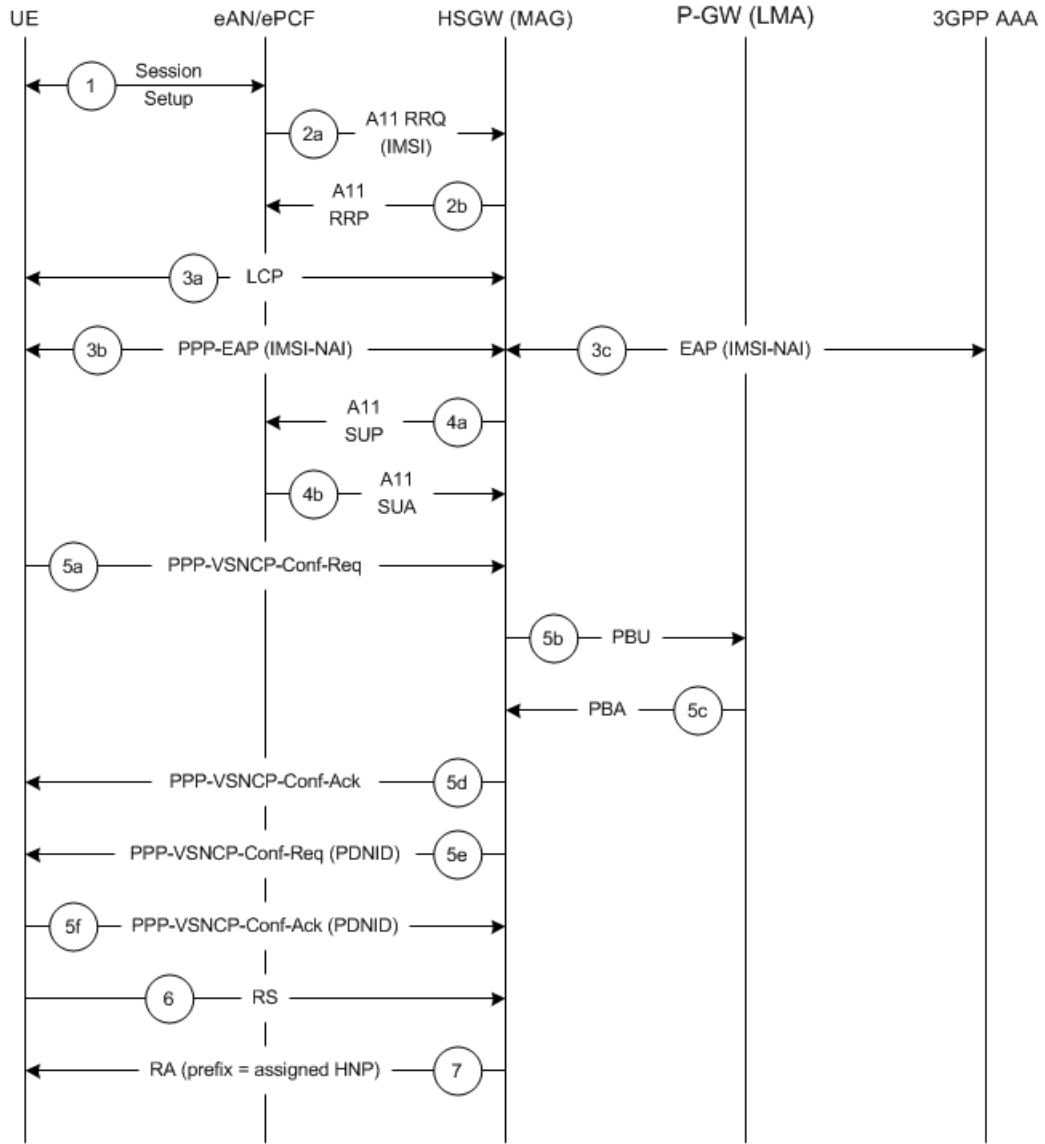

335317

Table 14: Initial Attach with IPv6/IPv4 Access Call Flow Description

Step	Description
1	The subscriber (UE) attaches to the eHRPD network.
2a	The eAN/PCF sends an A11 RRQ to the HSGW. The eAN/PCF includes the true IMSI of the UE in the A11 RRQ.
2b	The HSGW establishes A10s and respond back to the eAN/PCF with an A11 RRP.
3a	The UE performs LCP negotiation with the HSGW over the established main A10.
3b	The UE performs EAP over PPP.

Step	Description
3c	EAP authentication is completed between the UE and the 3GPP AAA. During this transaction, the HSGW receives the subscriber profile from the AAA server.
4a	After receiving the subscriber profile, the HSGW sends the QoS profile in A11 Session Update Message to the eAN/PCF.
4b	The eAN/PCF responds with an A11 Session Update Acknowledgment (SUA).
5a	The UE initiates a PDN connection by sending a PPP-VSNCP-Conf-Req message to the HSGW. The message includes the PDNID of the PDN, APN, PDN-Type=IPv6/[IPv4], PDSN-Address and, optionally, PCO options the UE is expecting from the network.
5b	The HSGW sends a PBU to the P-GW.
5c	The P-GW processes the PBU from the HSGW, assigns an HNP for the connection and responds back to the HSGW with PBA.
5d	The HSGW responds to the VSNCP Conf Req with a VSNCP Conf Ack.
5e	The HSGW sends a PPP-VSNCP-Conf-Req to the UE to complete PPP VSNCP negotiation.
5f	The UE completes VSNCP negotiation by returning a PPP-VSNCP-Conf-Ack.
6	The UE optionally sends a Router Solicitation (RS) message.
7	The HSGW sends a Router Advertisement (RA) message with the assigned Prefix.

PMIPv6 Lifetime Extension without Handover

This section describes the procedure of a session registration lifetime extension by the P-GW without the occurrence of a handover.

Figure 38: PMIPv6 Lifetime Extension (without handover) Call Flow

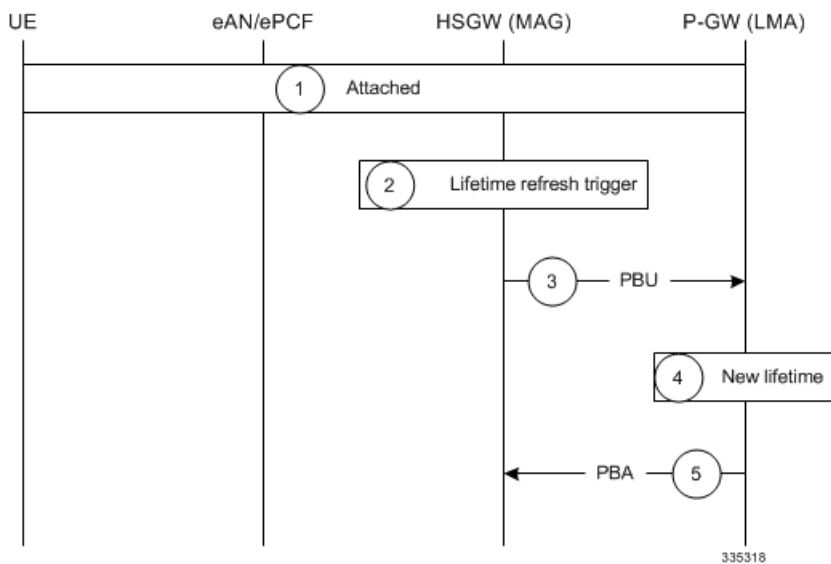

Table 15: PMIPv6 Lifetime Extension (without handover) Call Flow Description

Step	Description
1	The UE is attached to the EPC and has a PDN connection with the P-GW where PDNID=x and an APN with assigned HNP.
2	The HSGW MAG service registration lifetime nears expiration and triggers a renewal request for the LMA.
3	The MAG service sends a Proxy Binding Update (PBU) to the P-GW LMA service with the following attributes: Lifetime, MNID, APN, ATT=HRPD, HNP.
4	The P-GW LMA service updates the Binding Cache Entry (BCE) with the new granted lifetime.
5	The P-GW responds with a Proxy Binding Acknowledgment (PBA) with the following attributes: Lifetime, MNID, APN.

PDN Connection Release Initiated by UE

This section describes the procedure of a session release by the UE.

Figure 39: PDN Connection Release by the UE Call Flow

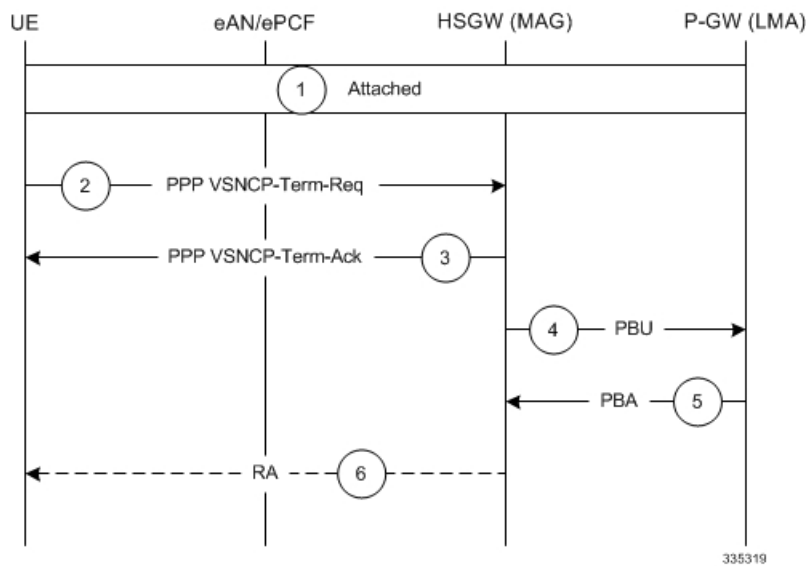

Table 16: PDN Connection Release by the UE Call Flow Description

Step	Description
1	The UE is attached to the EPC and has a PDN connection with the P-GW for PDN-ID=x and APN with assigned HNP.
2	The UE decides to disconnect from the PDN and sends a PPP VSNCP-Term-Req with PDNID=x.
3	The HSGW starts disconnecting the PDN connection and sends a PPP-VSNCP-Term-Ack to the UE (also with PDNID=x).
4	The HSGW begins the tear down of the PMIP session by sending a PBU Deregistration to the P-GW with the following attributes: Lifetime=0, MNID, APN, ATT=HRPD, HNP. The PBU Deregistration message should contain all the mobility options that were present in the initial PBU that created the binding.

Step	Description
5	The P-GW looks up the Binding Cache Entry (BCE) based on the HNP, deletes the binding, and responds to the HSGW with a Deregistration PBA with the same attributes (Lifetime=0, MNID, APN, ATT=HRPD, HNP).
6	The HSGW optionally sends a Router Advertisement (RA) with assigned HNP and prefix lifetime=0.

PDN Connection Release Initiated by HSGW

This section describes the procedure of a session release by the HSGW.

Figure 40: PDN Connection Release by the HSGW Call Flow

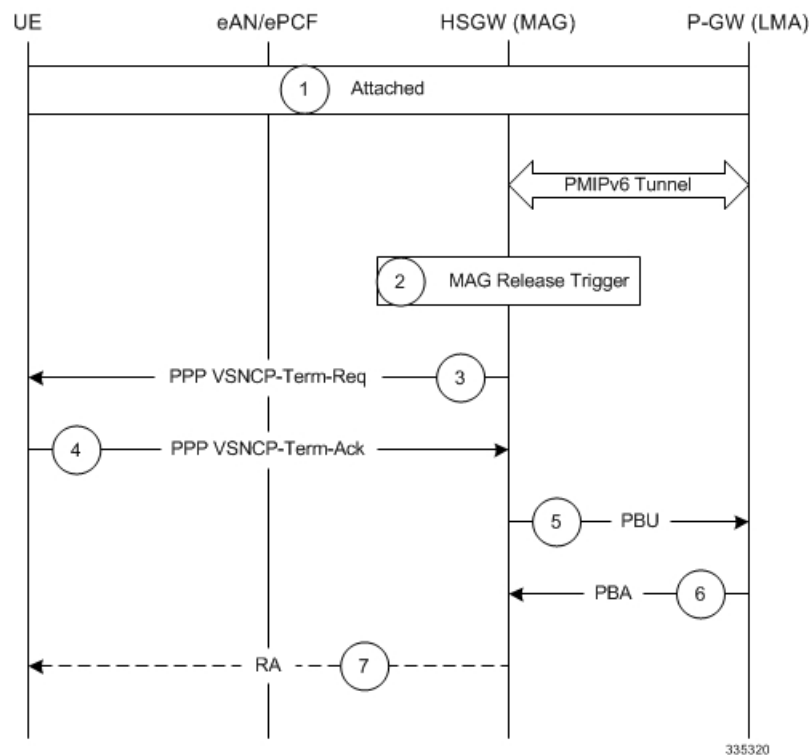

335320

Table 17: PDN Connection Release by the HSGW Call Flow Description

Step	Description
1	The UE is attached to the EPC and has a PDN connection with the P-GW for PDN-ID=x and APN with assigned HNP.
2	The HSGW MAG service triggers a disconnect of the PDN connection for PDNID=x.
3	The HSGW sends a PPP VSNCP-Term-Req with PDNID=x to the UE.
4	The UE acknowledges the receipt of the request with a VSNCP-Term-Ack (PDNID=x).
5	The HSGW begins the tear down of the PMIP session by sending a PBU Deregistration to the P-GW with the following attributes: Lifetime=0, MNID, APN, HNP. The PBU Deregistration message should contain all the mobility options that were present in the initial PBU that created the binding.

Step	Description
6	The P-GW looks up the BCE based on the HNP, deletes the binding, and responds to the HSGW with a Deregistration PBA with the same attributes (Lifetime=0, MNID, APN, ATT=HRPD, HNP).
7	The HSGW optionally sends a Router Advertisement (RA) with assigned HNP and prefix lifetime=0.

PDN Connection Release Initiated by P-GW

This section describes the procedure of a session release by the P-GW.

Figure 41: PDN Connection Release by the P-GW Call Flow

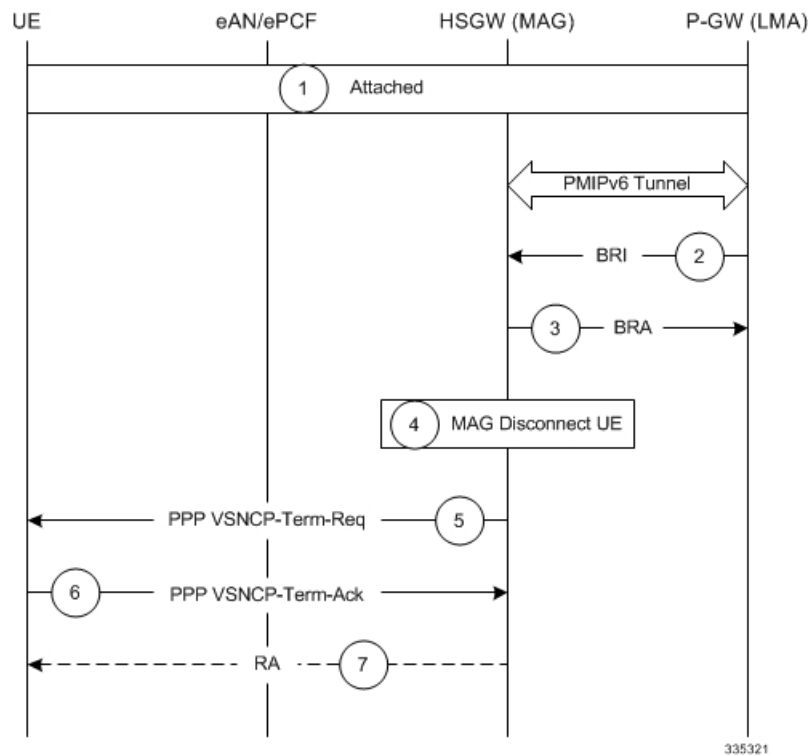

Table 18: PDN Connection Release by the P-GW Call Flow Description

Step	Description
1	The UE is attached to the EPC and has a PDN connection with the P-GW for PDN-ID=x and APN with assigned HNP.
2	A PGW trigger causes a disconnect of the PDN connection for PDNID=x and the PGW sends a Binding Revocation Indication (BRI) message to the HSGW with the following attributes: MNID, APN, HNP.
3	The HSGW responds to the BRI message with a Binding Revocation Acknowledgment (BRA) message with the same attributes (MNID, APN, HNP).
4	The HSGW MAG service triggers a disconnect of the UE PDN connection for PDNID=x.
5	The HSGW sends a PPP VSNCP-Term-Req with PDNID=x to the UE.
6	The UE acknowledges the receipt of the request with a VSNCP-Term-Ack (PDNID=x).

Step	Description
7	The HSGW optionally sends a Router Advertisement (RA) with assigned HNP and prefix lifetime=0.

GTP PDN Gateway Call/Session Procedures in an LTE-SAE Network

The following topics and procedure flows are included:

- [Subscriber-initiated Attach \(initial\)](#), on page 144
- [Subscriber-initiated Detach](#), on page 146

Subscriber-initiated Attach (initial)

This section describes the procedure of an initial attach to the EPC network by a subscriber.

Figure 42: Subscriber-initiated Attach (initial) Call Flow

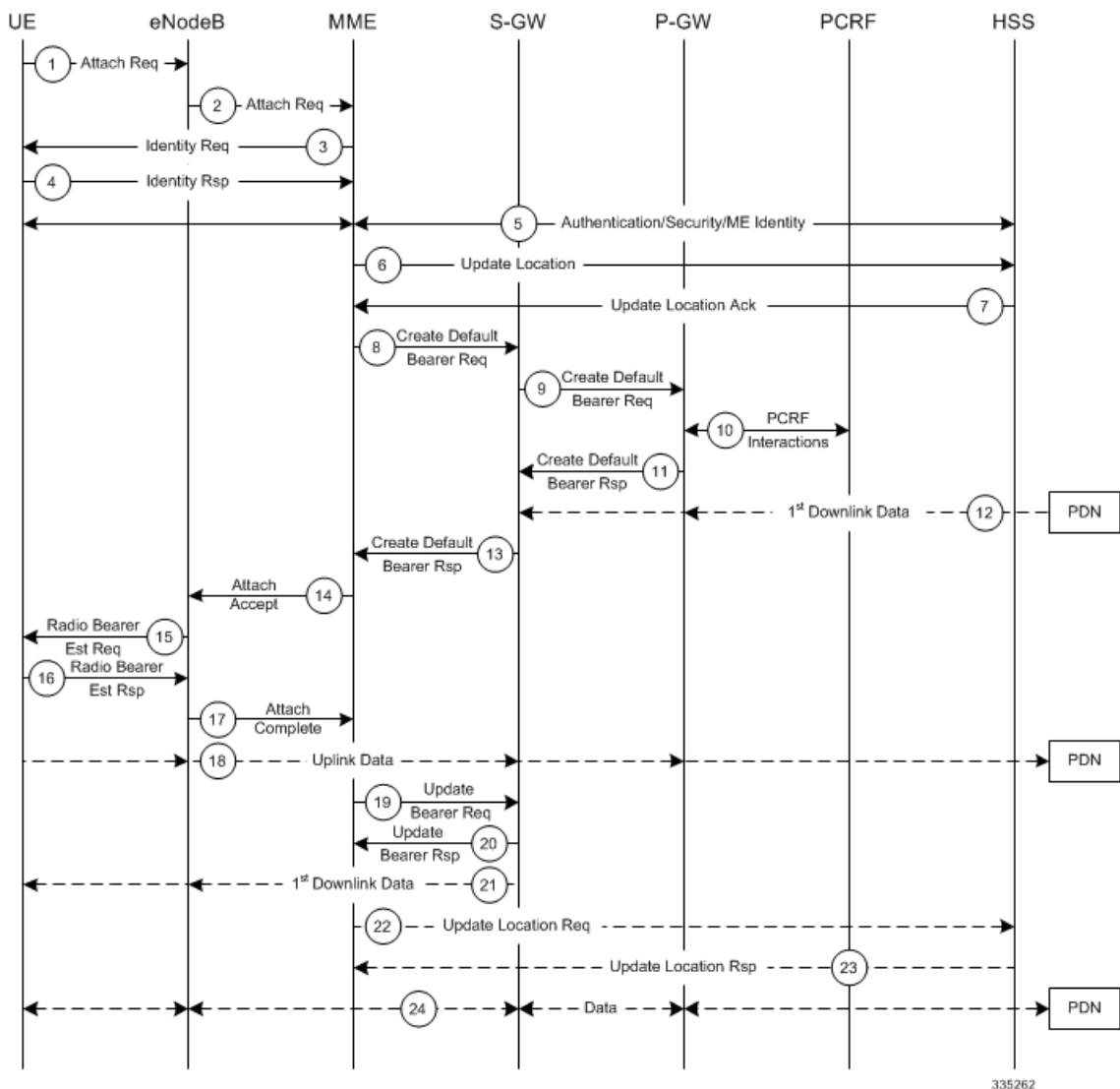

335262

Table 19: Subscriber-initiated Attach (initial) Call Flow Description 44

Step	Description
1	The UE initiates the Attach procedure by the transmission of an Attach Request (IMSI or old GUTI, last visited TAI (if available), UE Network Capability, PDN Address Allocation, Protocol Configuration Options, Attach Type) message together with an indication of the Selected Network to the eNodeB. IMSI is included if the UE does not have a valid GUTI available. If the UE has a valid GUTI, it is included.
2	The eNodeB derives the MME from the GUTI and from the indicated Selected Network. If that MME is not associated with the eNodeB, the eNodeB selects an MME using an "MME selection function". The eNodeB forwards the Attach Request message to the new MME contained in a S1-MME control message (Initial UE message) together with the Selected Network and an indication of the E-UTRAN Area identity, a globally unique E-UTRAN ID of the cell from where it received the message to the new MME.
3	If the UE is unknown in the MME, the MME sends an Identity Request to the UE to request the IMSI.
4	The UE responds with Identity Response (IMSI).
5	If no UE context for the UE exists anywhere in the network, authentication is mandatory. Otherwise this step is optional. However, at least integrity checking is started and the ME Identity is retrieved from the UE at Initial Attach. The authentication functions, if performed this step, involves AKA authentication and establishment of a NAS level security association with the UE in order to protect further NAS protocol messages.
6	The MME sends an Update Location (MME Identity, IMSI, ME Identity) to the HSS.
7	The HSS acknowledges the Update Location message by sending an Update Location Ack to the MME. This message also contains the Insert Subscriber Data (IMSI, Subscription Data) Request. The Subscription Data contains the list of all APNs that the UE is permitted to access, an indication about which of those APNs is the Default APN, and the 'EPS subscribed QoS profile' for each permitted APN. If the Update Location is rejected by the HSS, the MME rejects the Attach Request from the UE with an appropriate cause.
8	The MME selects an S-GW using "Serving GW selection function" and allocates an EPS Bearer Identity for the Default Bearer associated with the UE. If the PDN subscription context contains no P-GW address the MME selects a P-GW as described in clause "PDN GW selection function". Then it sends a Create Default Bearer Request (IMSI, MME Context ID, APN, RAT type, Default Bearer QoS, PDN Address Allocation, AMBR, EPS Bearer Identity, Protocol Configuration Options, ME Identity, User Location Information) message to the selected S-GW.
9	The S-GW creates a new entry in its EPS Bearer table and sends a Create Default Bearer Request (IMSI, APN, S-GW Address for the user plane, S-GW TEID of the user plane, S-GW TEID of the control plane, RAT type, Default Bearer QoS, PDN Address Allocation, AMBR, EPS Bearer Identity, Protocol Configuration Options, ME Identity, User Location Information) message to the P-GW.
10	If dynamic PCC is deployed, the P-GW interacts with the PCRF to get the default PCC rules for the UE. The IMSI, UE IP address, User Location Information, RAT type, AMBR are provided to the PCRF by the P-GW if received by the previous message.

Step	Description
11	The P-GW returns a Create Default Bearer Response (P-GW Address for the user plane, P-GW TEID of the user plane, P-GW TEID of the control plane, PDN Address Information, EPS Bearer Identity, Protocol Configuration Options) message to the S-GW. PDN Address Information is included if the P-GW allocated a PDN address Based on PDN Address Allocation received in the Create Default Bearer Request. PDN Address Information contains an IPv4 address for IPv4 and/or an IPv6 prefix and an Interface Identifier for IPv6. The P-GW takes into account the UE IP version capability indicated in the PDN Address Allocation and the policies of operator when the P-GW allocates the PDN Address Information. Whether the IP address is negotiated by the UE after completion of the Attach procedure, this is indicated in the Create Default Bearer Response.
12	The Downlink (DL) Data can start flowing towards S-GW. The S-GW buffers the data.
13	The S-GW returns a Create Default Bearer Response (PDN Address Information, S-GW address for User Plane, S-GW TEID for User Plane, S-GW Context ID, EPS Bearer Identity, Protocol Configuration Options) message to the new MME. PDN Address Information is included if it was provided by the P-GW.
14	The new MME sends an Attach Accept (APN, GUTI, PDN Address Information, TAI List, EPS Bearer Identity, Session Management Configuration IE, Protocol Configuration Options) message to the eNodeB.
15	The eNodeB sends Radio Bearer Establishment Request including the EPS Radio Bearer Identity to the UE. The Attach Accept message is also sent along to the UE.
16	The UE sends the Radio Bearer Establishment Response to the eNodeB. In this message, the Attach Complete message (EPS Bearer Identity) is included.
17	The eNodeB forwards the Attach Complete (EPS Bearer Identity) message to the MME.
18	The Attach is complete and UE sends data over the default bearer. At this time the UE can send uplink packets towards the eNodeB which are then tunneled to the S-GW and P-GW.
19	The MME sends an Update Bearer Request (eNodeB address, eNodeB TEID) message to the S-GW.
20	The S-GW acknowledges by sending Update Bearer Response (EPS Bearer Identity) message to the MME.
21	The S-GW sends its buffered downlink packets.
22	After the MME receives Update Bearer Response (EPS Bearer Identity) message, if an EPS bearer was established and the subscription data indicates that the user is allowed to perform handover to non-3GPP accesses, and if the MME selected a P-GW that is different from the P-GW address which was indicated by the HSS in the PDN subscription context, the MME sends an Update Location Request including the APN and P-GW address to the HSS for mobility with non-3GPP accesses.
23	The HSS stores the APN and P-GW address pair and sends an Update Location Response to the MME.
24	Bidirectional data is passed between the UE and PDN.

Subscriber-initiated Detach

This section describes the procedure of detachment from the EPC network by a subscriber.

Figure 43: Subscriber-initiated Detach Call Flow

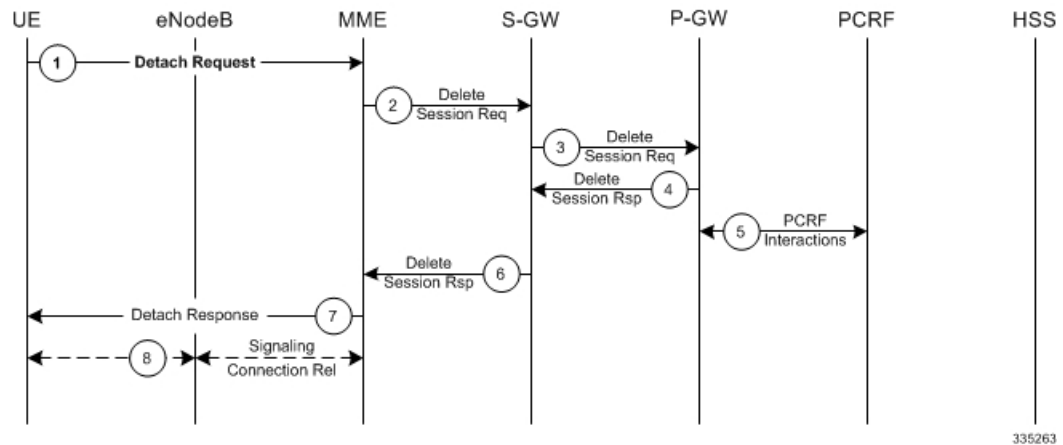

335263

Table 20: Subscriber-initiated Detach Call Flow Description

Step	Description
1	The UE sends NAS message Detach Request (GUTI, Switch Off) to the MME. Switch Off indicates whether detach is due to a switch off situation or not.
2	The active EPS Bearers in the S-GW regarding this particular UE are deactivated by the MME sending a Delete Bearer Request (TEID) message to the S-GW.
3	The S-GW sends a Delete Bearer Request (TEID) message to the P-GW.
4	The P-GW acknowledges with a Delete Bearer Response (TEID) message.
5	The P-GW may interact with the PCRF to indicate to the PCRF that EPS Bearer is released if PCRF is applied in the network.
6	The S-GW acknowledges with a Delete Bearer Response (TEID) message.
7	If Switch Off indicates that the detach is not due to a switch off situation, the MME sends a Detach Accept message to the UE.
8	The MME releases the S1-MME signaling connection for the UE by sending an S1 Release command to the eNodeB with Cause = Detach.

S-GW Supported Standards

The S-GW service complies with the following standards.

- [3GPP References, on page 148](#)
- [3GPP2 References, on page 150](#)
- [IETF References, on page 150](#)
- [Object Management Group \(OMG\) Standards, on page 151](#)

3GPP References

Release 12 3GPP References



Important The S-GW currently supports the following Release 12 3GPP specifications. Most 3GPP specifications are also used for 3GPP2 support; any specifications that are unique to 3GPP2 are listed under *3GPP2 References*.

- 3GPP TS 23.007: Restoration procedures
- 3GPP TS 23.401: General Packet Radio Service (GPRS) enhancements for Evolved Universal Terrestrial Radio Access Network (E-UTRAN) access
- 3GPP TS 29.274: 3GPP Evolved Packet System (EPS); Evolved General Packet Radio Service (GPRS) Tunneling Protocol for Control plane (GTPv2-C); Stage 3
- 3GPP TS 29.281: General Packet Radio System (GPRS) Tunneling Protocol User Plane (GTPv1-U)

Release 11 3GPP References



Important The S-GW currently supports the following Release 11 3GPP specifications. Most 3GPP specifications are also used for 3GPP2 support; any specifications that are unique to 3GPP2 are listed under *3GPP2 References*.

- 3GPP TS 23.007: Restoration procedures
- 3GPP TS 23.401: General Packet Radio Service (GPRS) enhancements for Evolved Universal Terrestrial Radio Access Network (E-UTRAN) access
- 3GPP TS 29.274: 3GPP Evolved Packet System (EPS); Evolved General Packet Radio Service (GPRS) Tunneling Protocol for Control plane (GTPv2-C); Stage 3
- 3GPP TS 29.281: General Packet Radio System (GPRS) Tunneling Protocol User Plane (GTPv1-U)
- 3GPP TS 32.423: Telecommunication management; Subscriber and equipment trace; Trace data definition and management.
- 3GPP TS 36.414: Evolved Universal Terrestrial Radio Access Network (E-UTRAN); S1 data transport

Release 10 3GPP References



Important The S-GW currently supports the following Release 10 3GPP specifications. Most 3GPP specifications are also used for 3GPP2 support; any specifications that are unique to 3GPP2 are listed under *3GPP2 References*.

- 3GPP TS 23.007: Restoration procedures
- 3GPP TS 23.401: General Packet Radio Service (GPRS) enhancements for Evolved Universal Terrestrial Radio Access Network (E-UTRAN) access

- 3GPP TS 29.274: 3GPP Evolved Packet System (EPS); Evolved General Packet Radio Service (GPRS) Tunnelling Protocol for Control plane (GTPv2-C); Stage 3
- 3GPP TS 29.281: General Packet Radio System (GPRS) Tunnelling Protocol User Plane (GTPv1-U)

Release 9 Supported Standards

- 3GPP TS 23.007: Restoration procedures
- 3GPP TS 23.060: General Packet Radio Service (GPRS); Service description; Stage 2
- 3GPP TS 23.216: Single Radio Voice Call Continuity (SRVCC); Stage 2 (Release 9)
- 3GPP TS 23.401: General Packet Radio Service (GPRS) enhancements for Evolved Universal Terrestrial Radio Access Network (E-UTRAN) access
- 3GPP TS 29.274: 3GPP Evolved Packet System (EPS); Evolved General Packet Radio Service (GPRS) Tunnelling Protocol for Control plane (GTPv2-C); Stage 3 (Release 9)
- 3GPP TS 29.281: General Packet Radio System (GPRS) Tunnelling Protocol User Plane (GTPv1-U)
- 3GPP TS 33.106: 3G Security; Lawful Interception Requirements
- 3GPP TS 36.414: Evolved Universal Terrestrial Radio Access Network (E-UTRAN); S1 data transport

Release 8 Supported Standards

- 3GPP TR 21.905: Vocabulary for 3GPP Specifications
- 3GPP TS 23.003: Numbering, addressing and identification
- 3GPP TS 23.007: Restoration procedures
- 3GPP TS 23.107: Quality of Service (QoS) concept and architecture
- 3GPP TS 23.203: Policy and charging control architecture
- 3GPP TS 23.401: General Packet Radio Service (GPRS) enhancements for Evolved Universal Terrestrial Radio Access Network (E-UTRAN) access
- 3GPP TS 23.402: Architecture Enhancements for non-3GPP accesses
- 3GPP TS 23.060: General Packet Radio Service (GPRS); Service description; Stage 2
- 3GPP TS 24.008: Mobile radio interface Layer 3 specification; Core network protocols
- 3GPP TS 24.229: IP Multimedia Call Control Protocol based on SIP and SDP; Stage 3
- 3GPP TS 29.210: Gx application
- 3GPP TS 29.212: Policy and Charging Control over Gx reference point
- 3GPP TS 29.213: Policy and Charging Control signaling flows and QoS
- 3GPP TS 29.214: Policy and Charging Control over Rx reference point
- 3GPP TS 29.274 V8.1.1 (2009-03): 3GPP Evolved Packet System (EPS); Evolved General Packet Radio Service (GPRS) Tunnelling Protocol for Control plane (GTPv2-C); Stage 3 (Release 8)

- 3GPP TS 29.274: Evolved GPRS Tunnelling Protocol for Control plane (GTPv2-C), version 8.2.0 (both versions are intentional)
- 3GPP TS 29.275: Proxy Mobile IPv6 (PMIPv6) based Mobility and Tunnelling protocols, version 8.1.0
- 3GPP TS 29.281: GPRS Tunnelling Protocol User Plane (GTPv1-U)
- 3GPP TS 32.251: Telecommunication management; Charging management; Packet Switched (PS) domain charging
- 3GPP TS 32.295: Charging management; Charging Data Record (CDR) transfer
- 3GPP TS 32.298: Telecommunication management; Charging management; Charging Data Record (CDR) encoding rules description
- 3GPP TS 32.299: Charging management; Diameter charging applications
- 3GPP TS 33.106: 3G Security; Lawful Interception Requirements
- 3GPP TS 36.107: 3G security; Lawful interception architecture and functions
- 3GPP TS 36.300: Evolved Universal Terrestrial Radio Access (E-UTRA) and Evolved Universal Terrestrial Radio Access Network (E-UTRAN); Overall description
- 3GPP TS 36.412. EUTRAN S1 signaling transport
- 3GPP TS 36.413: Evolved Universal Terrestrial Radio Access (E-UTRA); S1 Application Protocol (S1AP)
- 3GPP TS 36.414: Evolved Universal Terrestrial Radio Access Network (E-UTRAN); S1 data transport

3GPP2 References

- X.P0057-0 v0.11.0 E-UTRAN - eHRPD Connectivity and Interworking: Core Network Aspects

IETF References

- RFC 768: User Datagram Protocol (STD 6).
- RFC 791: Internet Protocol (STD 5).
- RFC 2131: Dynamic Host Configuration Protocol
- RFC 2460: Internet Protocol, Version 6 (IPv6) Specification
- RFC 2698: A Two Rate Three Color Marker
- RFC 2784: Generic Routing Encapsulation (GRE)
- RFC 2890: Key and Sequence Number Extensions to GRE
- RFC 3319: Dynamic Host Configuration Protocol (DHCPv6) Options for Session Initiation Protocol (SIP) Servers
- RFC 3588: Diameter Base Protocol
- RFC 3775: Mobility Support in IPv6

- RFC 3646: DNS Configuration options for Dynamic Host Configuration Protocol for IPv6 (DHCPv6)
- RFC 4006: Diameter Credit-Control Application
- RFC 4282: The Network Access Identifier
- RFC 4283: Mobile Node Identifier Option for Mobile IPv6 (MIPv6)
- RFC 4861: Neighbor Discovery for IP Version 6 (IPv6)
- RFC 4862: IPv6 Stateless Address Autoconfiguration
- RFC 5094: Mobile IPv6 Vendor Specific Option
- RFC 5213: Proxy Mobile IPv6
- Internet-Draft: Proxy Mobile IPv6
- Internet-Draft: GRE Key Option for Proxy Mobile IPv6, work in progress
- Internet-Draft: Binding Revocation for IPv6 Mobility, work in progress

Object Management Group (OMG) Standards

- CORBA 2.6 Specification 01-09-35, Object Management Group

P-GW Supported Standards

The P-GW service complies with the following standards.

- [Release 12 3GPP References, on page 151](#)
- [Release 11 3GPP References, on page 152](#)
- [Release 10 3GPP References, on page 152](#)
- [Release 9 3GPP References, on page 153](#)
- [Release 8 3GPP References, on page 154](#)
- [3GPP2 References, on page 155](#)
- [IETF References, on page 155](#)
- [Object Management Group \(OMG\) Standards, on page 156](#)

Release 12 3GPP References



Important

The P-GW currently supports the following Release 12 3GPP specifications. Most 3GPP specifications are also used for 3GPP2 support; any specifications that are unique to 3GPP2 are listed under *3GPP2 References*.

- 3GPP TS 23.007: Restoration procedures
- 3GPP TS 23.401: General Packet Radio Service (GPRS) enhancements for Evolved Universal Terrestrial Radio Access Network (E-UTRAN) access
- 3GPP TS 23.402: Architecture enhancements for non-3GPP accesses

- 3GPP TS 29.060: General Packet Radio Service (GPRS); GPRS Tunnelling Protocol (GTP) across the Gn and Gp interface
- 3GPP TS 29.274: 3GPP Evolved Packet System (EPS); Evolved General Packet Radio Service (GPRS) Tunnelling Protocol for Control plane (GTPv2-C); Stage 3
- 3GPP TS 29.281: General Packet Radio System (GPRS) Tunnelling Protocol User Plane (GTPv1-U)

Release 11 3GPP References



Important

The P-GW currently supports the following Release 11 3GPP specifications. Most 3GPP specifications are also used for 3GPP2 support; any specifications that are unique to 3GPP2 are listed under *3GPP2 References*.

- 3GPP TS 23.007: Restoration procedures
- 3GPP TS 29.274: 3GPP Evolved Packet System (EPS); Evolved General Packet Radio Service (GPRS) Tunnelling Protocol for Control plane (GTPv2-C)
- 3GPP TS 23.401: General Packet Radio Service (GPRS) enhancements for Evolved Universal Terrestrial Radio Access Network (E-UTRAN) access
- 3GPP TS 23.402: Architecture enhancements for non-3GPP accesses
- 3GPP TS 29.060: General Packet Radio Service (GPRS); GPRS Tunnelling Protocol (GTP) across the Gn and Gp interface
- 3GPP TS 29.274: 3GPP Evolved Packet System (EPS); Evolved General Packet Radio Service (GPRS) Tunnelling Protocol for Control plane (GTPv2-C); Stage 3
- 3GPP TS 29.281: General Packet Radio System (GPRS) Tunnelling Protocol User Plane (GTPv1-U)

Release 10 3GPP References



Important

The P-GW currently supports the following Release 10 3GPP specifications. Most 3GPP specifications are also used for 3GPP2 support; any specifications that are unique to 3GPP2 are listed under *3GPP2 References*.

- 3GPP TS 23.007: Restoration procedures
- 3GPP TS 23.203: Policy and charging control architecture; Stage 2
- 3GPP TS 23.401: General Packet Radio Service (GPRS) enhancements for Evolved Universal Terrestrial Radio Access Network (E-UTRAN) access
- 3GPP TS 23.402: Architecture enhancements for non-3GPP accesses
- 3GPP TS 29.212: Policy and Charging Control over Gx reference point
- 3GPP TS 29.274: 3GPP Evolved Packet System (EPS); Evolved General Packet Radio Service (GPRS) Tunnelling Protocol for Control plane (GTPv2-C)
- 3GPP TS 29.281: GPRS Tunnelling Protocol User Plane (GTPv1-U)

Release 9 3GPP References



Important The P-GW currently supports the following Release 9 3GPP specifications. Most 3GPP specifications are also used for 3GPP2 support; any specifications that are unique to 3GPP2 are listed under *3GPP2 References*.

- 3GPP TR 21.905: Vocabulary for 3GPP Specifications
- 3GPP TS 22.115: Service aspects; Charging and billing
- 3GPP TS 23.003: Numbering, addressing and identification
- 3GPP TS 23.007: Restoration procedures
- 3GPP TS 23.060: General Packet Radio Service (GPRS); Service description; Stage 2
- 3GPP TS 23.203: Policy and charging control architecture
- 3GPP TS 23.207: End-to-end Quality of Service (QoS) concept and architecture
- 3GPP TS 23.216: Single Radio Voice Call Continuity (SRVCC); Stage 2
- 3GPP TS 23.228: IP Multimedia Subsystem (IMS); Stage 2
- 3GPP TS 23.401: General Packet Radio Service (GPRS) enhancements for Evolved Universal Terrestrial Radio Access Network (E-UTRAN) access
- 3GPP TS 23.402: Architecture enhancements for non-3GPP accesses
- 3GPP TS 24.008: Mobile radio interface Layer 3 specification; Core network protocols
- 3GPP TS 29.060: General Packet Radio Service (GPRS); GPRS Tunnelling Protocol (GTP) across the Gn and Gp interface
- 3GPP TS 29.061: Interworking between the Public Land Mobile Network (PLMN) supporting packet based services and Packet Data Networks (PDN)
- 3GPP TS 29.212: Policy and Charging Control over Gx reference point
- 3GPP TS 29.214: Policy and Charging control over Rx reference point
- 3GPP TS 29.229: Cx and Dx interfaces based on Diameter protocol
- 3GPP TS 29.230: Diameter applications; 3GPP specific codes and identifiers
- 3GPP TS 29.272: Evolved Packet System (EPS); Mobility Management Entity (MME) and Serving GPRS Support Node (SGSN) related interfaces based on Diameter protocol
- 3GPP TS 29.273: 3GPP EPS AAA Interfaces
- 3GPP TS 29.274: 3GPP Evolved Packet System (EPS); Evolved General Packet Radio Service (GPRS) Tunnelling Protocol for Control plane (GTPv2-C); Stage 3
- 3GPP TS 29.275: Proxy Mobile IPv6 (PMIPv6) based Mobility and Tunnelling protocols; Stage 3
- 3GPP TS 29.281: General Packet Radio System (GPRS) Tunnelling Protocol User Plane (GTPv1-U)
- 3GPP TS 29.282: Mobile IPv6 vendor specific option format and usage within 3GPP

- 3GPP TS 32.240: Telecommunication management; Charging management; Charging architecture and principles
- 3GPP TS 32.251: Telecommunication management; Charging management; Packet Switched (PS) domain charging
- 3GPP TS 32.298: Telecommunication management; Charging management; Charging Data Record (CDR) parameter description
- 3GPP TS 32.299: Telecommunication management; Charging management; Diameter charging application

Release 8 3GPP References



Important The P-GW currently supports the following Release 8 3GPP specifications. Most 3GPP specifications are also used for 3GPP2 support; any specifications that are unique to 3GPP2 are listed under *3GPP2 References*.

- 3GPP TR 21.905: Vocabulary for 3GPP Specifications
- 3GPP TS 23.003: Numbering, addressing and identification
- 3GPP TS 23.007: Restoration procedures
- 3GPP TS 23.060. General Packet Radio Service (GPRS); Service description; Stage 2
- 3GPP TS 23.107: Quality of Service (QoS) concept and architecture
- 3GPP TS 23.203: Policy and charging control architecture
- 3GPP TS 23.401: General Packet Radio Service (GPRS) enhancements for Evolved Universal Terrestrial Radio Access Network (E-UTRAN) access
- 3GPP TS 23.402. Architecture enhancements for non-3GPP accesses
- 3GPP TS 23.869: Support for Internet Protocol (IP) based IP Multimedia Subsystem (IMS) Emergency calls over General Packet Radio Service (GPRS) and Evolved Packet Service (EPS)
- 3GPP TS 24.008: Mobile radio interface Layer 3 specification; Core network protocols
- 3GPP TS 24.229: IP Multimedia Call Control Protocol based on SIP and SDP; Stage 3
- 3GPP TS 27.060: Mobile Station (MS) supporting Packet Switched Services
- 3GPP TS 29.061: Interworking between the Public Land Mobile Network (PLMN) supporting packet based services and Packet Data Networks (PDN)
- 3GPP TS 29.210. Charging rule provisioning over Gx interface
- 3GPP TS 29.212: Policy and Charging Control over Gx reference point
- 3GPP TS 29.213: Policy and Charging Control signaling flows and QoS
- 3GPP TS 29.273: 3GPP EPS AAA Interfaces
- 3GPP TS 29.274: Evolved GPRS Tunnelling Protocol for Control plane (GTPv2-C)
- 3GPP TS 29.275: Proxy Mobile IPv6 (PMIPv6) based Mobility and Tunnelling protocols

- 3GPP TS 29.281: GPRS Tunnelling Protocol User Plane (GTPv1-U)
- 3GPP TS 29.282: Mobile IPv6 vendor specific option format and usage within 3GPP
- 3GPP TS 32.295: Charging management; Charging Data Record (CDR) transfer
- 3GPP TS 32.298: Telecommunication management; Charging management; Charging Data Record (CDR) encoding rules description
- 3GPP TS 32.299: Charging management; Diameter charging applications
- 3GPP TS 36.300. EUTRA and EUTRAN; Overall description Stage 2
- 3GPP TS 36.412. EUTRAN S1 signaling transport
- 3GPP TS 36.413. EUTRAN S1 Application Protocol (S1AP)

3GPP2 References

- X.S0057-0 v3.0 E-UTRAN - eHRPD Connectivity and Interworking: Core Network Aspects

IETF References

- RFC 768: User Datagram Protocol (STD 6).
- RFC 791: Internet Protocol (STD 5).
- RFC 1701, Generic Routing Encapsulation (GRE)
- RFC 1702, Generic Routing Encapsulation over IPv4 networks
- RFC 2131: Dynamic Host Configuration Protocol
- RFC 2460: Internet Protocol, Version 6 (IPv6) Specification
- RFC 2473: Generic Packet Tunneling in IPv6 Specification
- RFC 2698: A Two Rate Three Color Marker
- RFC 2784: Generic Routing Encapsulation (GRE)
- RFC 2890: Key and Sequence Number Extensions to GRE
- RFC 3162: RADIUS and IPv6
- RFC 3266: Support for IPv6 in Session Description Protocol (SDP)
- RFC 3319: Dynamic Host Configuration Protocol (DHCPv6) Options for Session Initiation Protocol (SIP) Servers
- RFC 3588: Diameter Base Protocol
- RFC 3589: Diameter Command Codes for Third Generation Partnership Project (3GPP) Release 5
- RFC 3646: DNS Configuration options for Dynamic Host Configuration Protocol for IPv6 (DHCPv6)
- RFC 3775: Mobility Support in IPv6

- RFC 4004: Diameter Mobile IPv4 Application
- RFC 4005: Diameter Network Access Server Application
- RFC 4006: Diameter Credit-Control Application
- RFC 4282: The Network Access Identifier
- RFC 4283: Mobile Node Identifier Option for Mobile IPv6 (MIPv6)
- RFC 4861: Neighbor Discovery for IP Version 6 (IPv6)
- RFC 4862: IPv6 Stateless Address Autoconfiguration
- RFC 5094: Mobile IPv6 Vendor Specific Option
- RFC 5149: Service Selection for Mobile IPv6
- RFC 5213: Proxy Mobile IPv6
- RFC 5447: Diameter Mobile IPv6: Support for NAS to Diameter Server Interaction
- RFC 5555: Mobile IPv6 Support for Dual Stack Hosts and Routers
- RFC 5844: IPv4 Support for Proxy Mobile IPv6
- RFC 5845: Generic Routing Encapsulation (GRE) Key Option for Proxy Mobile IPv6
- RFC 5846: Binding Revocation for IPv6 Mobility
- Internet-Draft (draft-ietf-dime-qos-attributes-07): QoS Attributes for Diameter
- Internet-Draft (draft-ietf-mip6-nemo-v4traversal-06.txt): Mobile IPv6 support for dual stack Hosts and Routers (DSMIPv6)
- Internet-Draft (draft-ietf-netlmm-grekey-option-01.txt): GRE Key Option for Proxy Mobile IPv6, work in progress
- Internet-Draft (draft-ietf-netlmm-pmip6-ipv4-support-02.txt) IPv4 Support for Proxy Mobile IPv6
- Internet-Draft (draft-ietf-netlmm-proxymip6-07.txt): Proxy Mobile IPv6
- Internet-Draft (draft-ietf-mext-binding-revocation-02.txt): Binding Revocation for IPv6 Mobility, work in progress
- Internet-Draft (draft-meghana-netlmm-pmip6-mip4-00.txt) Proxy Mobile IPv6 and Mobile IPv4 interworking

Object Management Group (OMG) Standards

- CORBA 2.6 Specification 01-09-35, Object Management Group



CHAPTER 2

SAE Gateway Configuration

This chapter provides configuration information for the SAE Gateway (SAEGW).



Important Information about all commands in this chapter can be found in the *Command Line Interface Reference*.

Because each wireless network is unique, the system is designed with a variety of parameters allowing it to perform in various wireless network environments. In this chapter, only the minimum set of parameters are provided to make the system operational. Optional configuration commands specific to the SAEGW product are located in the *Command Line Interface Reference*.

- [Configuring an SAEGW Service, on page 157](#)
- [Configuring an eGTP S-GW Service, on page 160](#)
- [Configuring Optional Features on the eGTP S-GW, on page 169](#)
- [Configuring an eGTP P-GW Service, on page 187](#)
- [Configuring Optional Features on the P-GW, on page 212](#)

Configuring an SAEGW Service

This section provides a high-level series of steps and the associated configuration file examples for configuring the system to perform as an SAEGW in a test environment. Information provided in this section includes the following:

- [Information Required, on page 157](#)
- [SAEGW Configuration, on page 159](#)

Information Required

The following sections describe the minimum amount of information required to configure and make the SAEGW operational on the network. To make the process more efficient, it is recommended that this information be available prior to configuring the system.

There are additional configuration parameters that are not described in this section. These parameters deal mostly with fine-tuning the operation of the SAEGW in the network. Information on these parameters can be found in the appropriate sections of the *Command Line Interface Reference*.

Required Local Context Configuration Information

The following table lists the information that is required to configure the local context on an SAEGW.

Table 21: Required Information for Local Context Configuration

Required Information	Description
Management Interface Configuration	
Interface name	An identification string between 1 and 79 characters (alpha and/or numeric) by which the interface will be recognized by the system. Multiple names are needed if multiple interfaces will be configured.
IP address and subnet	IPv4 addresses assigned to the interface. Multiple addresses and subnets are needed if multiple interfaces will be configured.
Physical port number	The physical port to which the interface will be bound. Ports are identified by the chassis slot number where the line card resides followed by the number of the physical connector on the card. For example, port 17/1 identifies connector number 1 on the card in slot 17. A single physical port can facilitate multiple interfaces.
Gateway IP address	Used when configuring static IP routes from the management interface(s) to a specific network.
Security administrator name	The name or names of the security administrator with full rights to the system.
Security administrator password	Open or encrypted passwords can be used.
Remote access type(s)	The type of remote access that will be used to access the system such as telnetd, sshd, and/or ftpd.

Required SAEGW Context Configuration Information

The following table lists the information that is required to configure the SAEGW context on an SAEGW.

Table 22: Required Information for SAEGW Context Configuration

Required Information	Description
SAEGW context name	An identification string from 1 to 79 characters (alpha and/or numeric) by which the SAEGW context will be recognized by the system.
SAEGW Service Configuration	
SAEGW service name	An identification string from 1 to 63 characters (alpha and/or numeric) by which the SAEGW service will be recognized by the system.
S-GW service name	An identification string from 1 to 63 characters (alpha and/or numeric) by which the S-GW service will be recognized by the system.

Required Information	Description
P-GW service name	An identification string from 1 to 63 characters (alpha and/or numeric) by which the P-GW service will be recognized by the system.

SAEGW Configuration

-
- Step 1** Set system configuration parameters such as activating PSCs by applying the example configurations found in the *System Administration Guide*.
 - Step 2** Set initial configuration parameters such as creating contexts and services by applying the example configurations found in [Initial Configuration, on page 159](#).
 - Step 3** Configure the system to perform as an SAEGW and associate an eGTP S-GW service and eGTP P-GW service by applying the example configurations presented in [SAEGW Service Configuration, on page 160](#).
 - Step 4** Verify and save the configuration by following the steps found in [Verifying and Saving the Configuration, on page 160](#).
-

Initial Configuration

-
- Step 1** Set local system management parameters by applying the example configuration in [Modifying the Local Context, on page 159](#).
 - Step 2** Create the context where the SAEGW, S-GW, and P-GW services will reside by applying the example configuration in [Creating and Configuring an SAEGW Context, on page 160](#).
 - Step 3** Configure an eGTP S-GW service by applying the example configurations found in [Configuring an eGTP S-GW Service, on page 160](#).
 - Step 4** Configure an eGTP P-GW service by applying the example configurations found in [Configuring an eGTP P-GW Service, on page 187](#).
-

Modifying the Local Context

Use the following example to set the default subscriber and configure remote access capability in the local context:

```

configure
context local
interface <lcl_cntxt_intrfc_name>
ip address <ip_address> <ip_mask>
exit
server ftpd
exit
server telnetd
exit
subscriber default
exit
administrator <name> encrypted password <password> ftp
ip route <ip_addr/ip_mask> <next_hop_addr> <lcl_cntxt_intrfc_name>

```

```

exit
port ethernet <slot/port>
  no shutdown
  bind interface <lcl_cntxt_intrfc_name> local
end

```

Notes:

- Service names must be unique across all contexts within a chassis.

Creating and Configuring an SAEGW Context

Use the following example to create the context where the SAEGW, S-GW, and P-GW services will reside:

```

configure
  context <saegw_context_name>
end

```

SAEGW Service Configuration

Configure the SAEGW service by applying the example configuration in [Configuring the SAEGW Service, on page 160](#).

Configuring the SAEGW Service

Use the following example to configure the SAEGW service:

```

configure
  context <saegw_context_name>
    saegw-service <saegw_service_name> -noconfirm
    associate sgw-service <sgw_service_name>
    associate pgw-service <pgw_service_name>
  end

```

Notes:

- The SAEGW, S-GW, and P-GW services must all reside within the same SAEGW context.
- Service names must be unique across all contexts within a chassis.

Verifying and Saving the Configuration

Save your configuration to flash memory, an external memory device, and/or a network location using the Exec mode command **save configuration**. For additional information on how to verify and save configuration files, refer to the *System Administration Guide* and the *Command Line Interface Reference*.

Configuring an eGTP S-GW Service

This section provides a high-level series of steps and the associated configuration file examples for configuring the system to perform as an eGTP S-GW in a test environment. Information provided in this section includes the following:

- [Information Required, on page 161](#)

- [How This Configuration Works, on page 163](#)
- [eGTP S-GW Configuration, on page 164](#)

Information Required

The following sections describe the minimum amount of information required to configure and make the S-GW operational on the network. To make the process more efficient, you should have this information available prior to configuring the system.

There are additional configuration parameters that are not described in this section. These parameters deal mostly with fine-tuning the operation of the S-GW in the network. Information on these parameters can be found in the appropriate sections of the *Command Line Interface Reference*.

Required S-GW Ingress Context Configuration Information

The following table lists the information that is required to configure the S-GW ingress context on an eGTP S-GW.

Table 23: Required Information for S-GW Ingress Context Configuration

Required Information	Description
S-GW ingress context name	An identification string from 1 to 79 characters (alpha and/or numeric) by which the S-GW ingress context is recognized by the system. Note The S-GW service must reside within the SAEGW context, thus this would be the SAEGW context name.
Accounting policy name	An identification string from 1 to 63 characters (alpha and/or numeric) by which the accounting policy is recognized by the system. The accounting policy is used to set parameters for the Rf (off-line charging) interface. Important In StarOS releases 19 and later, the Rf interface is not supported on the S-GW.
S1-U/S11 Interface Configuration (To/from eNodeB/MME)	
Note The configuration provided in this guide assumes a shared S1-U/S11 interface. These interfaces can be separated to support a different network architecture. The information below applies to both.	
Interface name	An identification string between 1 and 79 characters (alpha and/or numeric) by which the interface is recognized by the system. Multiple names are needed if multiple interfaces will be configured.
IP address and subnet	IPv4 or IPv6 addresses assigned to the interface. Multiple addresses and subnets are needed if multiple interfaces will be configured.

Required Information	Description
Physical port number	The physical port to which the interface will be bound. Ports are identified by the chassis slot number where the line card resides followed by the number of the physical connector on the card. For example, port 17/1 identifies connector number 1 on the card in slot 17. A single physical port can facilitate multiple interfaces.
Gateway IP address	Used when configuring static IP routes from the interface(s) to a specific network.
Gateway IP address	Used when configuring static IP routes from the interface(s) to a specific network.
GTP-U Service Configuration	
GTP-U service name (for S1-U/S11 interface)	An identification string from 1 to 63 characters (alpha and/or numeric) by which the GTP-U service bound to the S1-U/S11 interface will be recognized by the system.
IP address	S1-U/S11 interface IPv4 or IPv6 address.
S-GW Service Configuration	
S-GW service name	An identification string from 1 to 63 characters (alpha and/or numeric) by which the S-GW service is recognized by the system. Multiple names are needed if multiple S-GW services will be used.
eGTP Ingress Service Configuration	
eGTP S1-U/S11 ingress service name	An identification string from 1 to 63 characters (alpha and/or numeric) by which the eGTP S1-U/S11 ingress service is recognized by the system.

Required S-GW Egress Context Configuration Information

The following table lists the information that is required to configure the S-GW egress context on an eGTP S-GW.

Table 24: Required Information for S-GW Egress Context Configuration

Required Information	Description
S-GW egress context name	An identification string from 1 to 79 characters (alpha and/or numeric) by which the S-GW egress context is recognized by the system. Note The S-GW service must reside within the SAEGW context, thus this would be the SAEGW context name.
S5/S8 Interface Configuration (To/from P-GW)	
Interface name	An identification string between 1 and 79 characters (alpha and/or numeric) by which the interface is recognized by the system. Multiple names are needed if multiple interfaces will be configured.

Required Information	Description
IP address and subnet	IPv4 or IPv6 addresses assigned to the interface. Multiple addresses and subnets are needed if multiple interfaces will be configured.
Physical port number	The physical port to which the interface will be bound. Ports are identified by the chassis slot number where the line card resides followed by the number of the physical connector on the card. For example, port 17/1 identifies connector number 1 on the card in slot 17. A single physical port can facilitate multiple interfaces.
Gateway IP address	Used when configuring static IP routes from the interface(s) to a specific network.
GTP-U Service Configuration	
GTP-U service name (for S5/S8 interface)	An identification string from 1 to 63 characters (alpha and/or numeric) by which the GTP-U service bound to the S5/S8 interface will be recognized by the system.
IP address	S5/S8 interface IPv4 or IPv6 address.
eGTP Egress Service Configuration	
eGTP Egress Service Name	An identification string from 1 to 63 characters (alpha and/or numeric) by which the eGTP egress service is recognized by the system.

How This Configuration Works

The following figure and supporting text describe how this configuration with a single ingress and egress context is used by the system to process a subscriber call.

Figure 44: eGTP S-GW Call Processing Using a Single Ingress and Egress Context

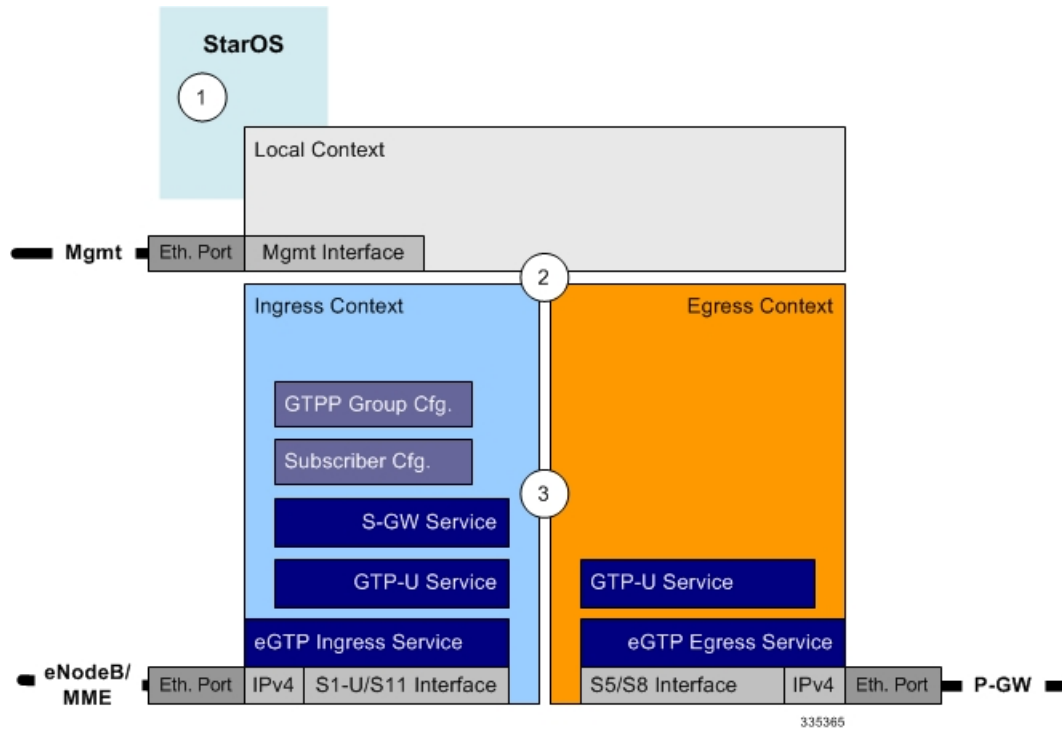

1. A subscriber session from the MME is received by the S-GW service over the S11 interface.
2. The S-GW service determines which context to use to access PDN services for the session. This process is described in the How the System Selects Contexts section located in the Understanding the System Operation and Configuration chapter of the System Administration Guide.
3. S-GW uses the configured egress context to determine the eGTP service to use for the outgoing S5/S8 connection.
4. The S-GW establishes the S5/S8 connection by sending a create session request message to the P-GW.
5. The P-GW responds with a Create Session Response message that includes the PGW S5/S8 Address for control plane and bearer information.
6. The S-GW conveys the control plane and bearer information to the MME in a Create Session Response message.
7. The MME responds with a Create Bearer Response and Modify Bearer Request message.
8. The S-GW sends a Modify Bearer Response message to the MME.

eGTP S-GW Configuration

To configure the system to perform as an eGTP S-GW, review the following graphic and subsequent steps.

Figure 45: eGTP S-GW Configurable Components

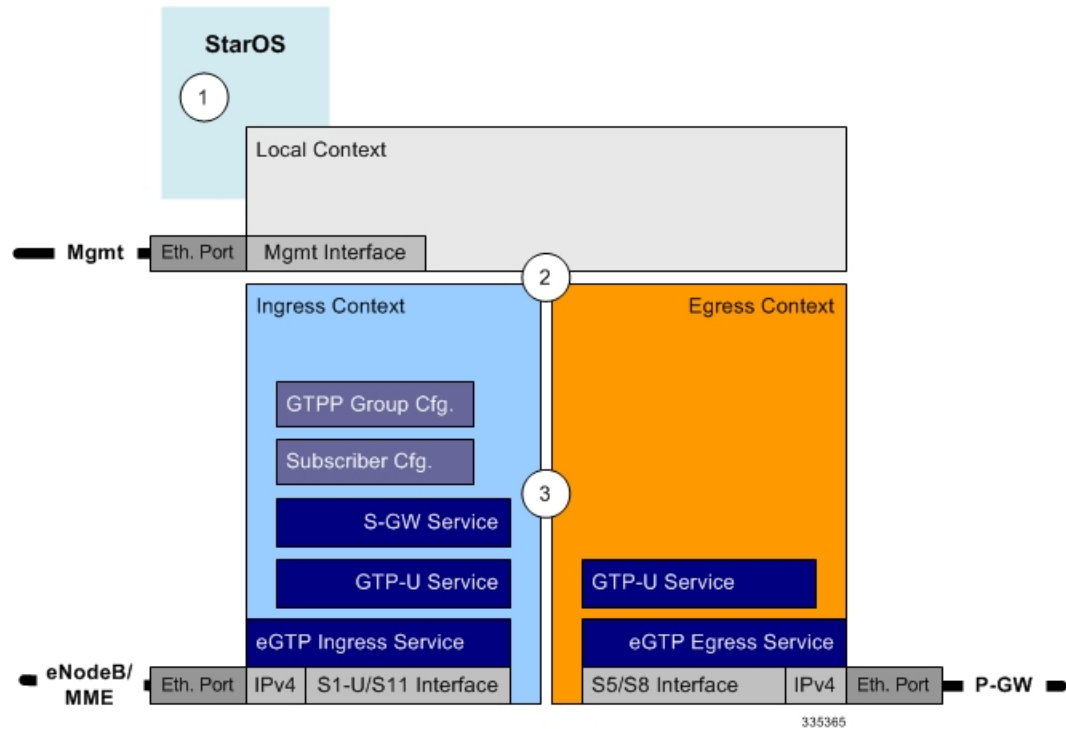

335365

-
- Step 1** Set system configuration parameters such as activating PSCs by applying the example configurations found in the System Administration Guide.
 - Step 2** Set initial configuration parameters such as creating contexts and services by applying the example configurations found in [Initial Configuration, on page 165](#).
 - Step 3** Configure the system to perform as an eGTP S-GW and set basic S-GW parameters such as eGTP interfaces and an IP route by applying the example configurations presented in [eGTP Configuration, on page 167](#).
 - Step 4** Verify and save the configuration by following the instruction in [Verifying and Saving the Configuration, on page 169](#).
-

Initial Configuration

-
- Step 1** Create an ingress context where the S-GW and eGTP ingress service will reside by applying the example configuration in [Creating an S-GW Ingress Context, on page 166](#).
 - Step 2** Create an eGTP ingress service within the newly created ingress context by applying the example configuration in [Creating an eGTP Ingress Service, on page 166](#).
 - Step 3** Create an S-GW egress context where the eGTP egress services will reside by applying the example configuration in [Creating an S-GW Egress Context, on page 166](#).
 - Step 4** Create an eGTP egress service within the newly created egress context by applying the example configuration in [Creating an eGTP Egress Service, on page 167](#).

- Step 5** Create a S-GW service within the newly created ingress context by applying the example configuration in [Creating an S-GW Service, on page 167](#).

Creating an S-GW Ingress Context

Use the following example to create an S-GW ingress context and Ethernet interfaces to an MME and eNodeB, and bind the interfaces to configured Ethernet ports.

```
configure
context <saegw_context_name> -noconfirm
subscriber default
exit
interface <slu-s11_interface_name>
ip address <ipv4_address_primary>
ip address <ipv4_address_secondary>
exit
ip route 0.0.0.0 0.0.0.0 <next_hop_address> <sgw_interface_name>
exit
port ethernet <slot_number/port_number>
no shutdown
bind interface <slu-s11_interface_name> <saegw_context_name>
end
```

Notes:

- This example presents the S1-U/S11 connections as a shared interface. These interfaces can be separated to support a different network architecture.
- The S1-U/S11 interface IP address(es) can also be specified as IPv6 addresses using the **ipv6 address** command.
- Service names must be unique across all contexts within a chassis.

Creating an eGTP Ingress Service

Use the following configuration example to create an eGTP ingress service:

```
configure
context <saegw_context_name>
egtp-service <egtp_ingress_service_name> -noconfirm
end
```

Notes:

- Service names must be unique across all contexts within a chassis.

Creating an S-GW Egress Context

Use the following example to create an S-GW egress context and Ethernet interface to a P-GW and bind the interface to configured Ethernet ports.

```
configure
context <egress_context_name> -noconfirm
interface <s5s8_interface_name> tunnel
ipv6 address <address>
tunnel-mode ipv6ip
```

```

        source interface <name>
        destination address <ipv4 or ipv6 address>
    end
configure
    port ethernet <slot_number/port_number>
    no shutdown
    bind interface <s5s8_interface_name> <egress_context_name>
end

```

Notes:

- The S5/S8 interface IP address can also be specified as an IPv4 address using the **ip address** command.
- Service names must be unique across all contexts within a chassis.

Creating an eGTP Egress Service

Use the following configuration example to create an eGTP egress service in the S-GW egress context:

```

configure
    context <egress_context_name>
        egtp-service <egtp_egress_service_name> -noconfirm
    end

```

Notes:

- Service names must be unique across all contexts within a chassis.

Creating an S-GW Service

Use the following configuration example to create the S-GW service in the ingress context:

```

configure
    context <saegw_context_name>
        sgw-service <sgw_service_name> -noconfirm
    end

```

Notes:

- Service names must be unique across all contexts within a chassis.

eGTP Configuration

-
- Step 1** Set the system's role as an eGTP S-GW and configure eGTP service settings by applying the example configuration in [Setting the System's Role as an eGTP S-GW and Configuring GTP-U and eGTP Service Settings](#), on page 167.
 - Step 2** Configure the S-GW service by applying the example configuration in [Configuring the S-GW Service](#), on page 168.
 - Step 3** Specify an IP route to the eGTP Serving Gateway by applying the example configuration in [Configuring an IP Route](#), on page 169.
-

Setting the System's Role as an eGTP S-GW and Configuring GTP-U and eGTP Service Settings

Use the following configuration example to set the system to perform as an eGTP S-GW and configure the GTP-U and eGTP services.



Important If you modify the **interface-type** command, the parent service (service within which the eGTP/GTP-U service is configured) will automatically restart. Service restart results in dropping of active calls associated with the parent service.

```

configure
  context <saegw_context_name>
    gtp group default
    exit
  gtpu-service <gtpu_ingress_service_name>
    bind ipv4-address <s1-u_s11_interface_ip_address>
    exit
  egtp-service <egtp_ingress_service_name>
    interface-type interface-sgw-ingress
    validation-mode default
    associate gtpu-service <gtpu_ingress_service_name>
    gtpc bind address <s1u-s11_interface_ip_address>
    exit
  exit
  context <sgw_egress_context_name>
    gtpu-service <gtpu_egress_service_name>
    bind ipv4-address <s5s8_interface_ip_address>
    exit
    egtp-service <egtp_egress_service_name>
    interface-type interface-sgw-egress
    validation-mode default
    associate gtpu-service <gtpu_egress_service_name>
    gtpc bind address <s5s8_interface_ip_address>
    end

```

Notes:

- The **bind** command in the GTP-U ingress and egress service configuration can also be specified as an IPv6 address using the **ipv6-address** command.
- Service names must be unique across all contexts within a chassis.

Configuring the S-GW Service

Use the following example to configure the S-GW service:

```

configure
  context <saegw_context_name>
    sgw-service <sgw_service_name> -noconfirm
    associate ingress egtp-service <egtp_ingress_service_name>
    associate egress-proto gtp egress-context <egress_context_name>
    qci-qos-mapping <map_name>
    end

```

Notes:

- Service names must be unique across all contexts within a chassis.

Configuring an IP Route

Use the following example to configure an IP Route for control and user plane data communication with an eGTP PDN Gateway:

```
configure
context <egress_context_name>
  ip route <pgw_ip_addr/mask> <sgw_next_hop_addr> <sgw_intrfc_name>
end
```

Notes:

- Service names must be unique across all contexts within a chassis.

Verifying and Saving the Configuration

Save your configuration to flash memory, an external memory device, and/or a network location using the Exec mode command **save configuration**. For additional information on how to verify and save configuration files, refer to the *System Administration Guide* and the *Command Line Interface Reference*.

Configuring Optional Features on the eGTP S-GW

The configuration examples in this section are optional and provided to cover the most common uses of the eGTP S-GW in a live network. The intent of these examples is to provide a base configuration for testing.

The following optional configurations are provided in this section:

- [Configuring the GTP Echo Timer, on page 169](#)
- [Configuring GTP Offline Accounting on the S-GW, on page 175](#)
- [Configuring Diameter Offline Accounting on the S-GW, on page 176](#)
- [Configuring APN-level Traffic Policing on the S-GW, on page 177](#)
- [Configuring X.509 Certificate-based Peer Authentication, on page 178](#)
- [Configuring Dynamic Node-to-Node IP Security on the S1-U and S5 Interfaces, on page 179](#)
- [Configuring ACL-based Node-to-Node IP Security on the S1-U and S5 Interfaces, on page 181](#)
- [Configuring R12 Load Control Support, on page 184](#)
- [Configuring R12 Overload Control Support, on page 185](#)
- [Configuring S4 SGSN Handover Capability, on page 186](#)

Configuring the GTP Echo Timer

The GTP echo timer on the ASR5500 S-GW can be configured to support two different types of path management: default and dynamic. This timer can be configured on the GTP-C and/or the GTP-U channels.

Default GTP Echo Timer Configuration

The following examples describe the configuration of the default eGTP-C and GTP-U interface echo timers:

eGTP-C

```
configure
configure
context <context_name>
```

```

egtp-service <egtp_service_name>
  gtpc echo-interval <seconds>
  gtpc echo-retransmission-timeout <seconds>
  gtpc max-retransmissions <num>
end

```

Notes:

- This configuration can be used in either the ingress context supporting the S1-U and/or S11 interfaces with the eNodeB and MME respectively; and the egress context supporting the S5/S8 interface with the P-GW.
- Service names must be unique across all contexts within a chassis.
- The following diagram describes a failure and recovery scenario using default settings of the three **gtpc** commands in the example above:

Figure 46: Failure and Recovery Scenario: Example 1

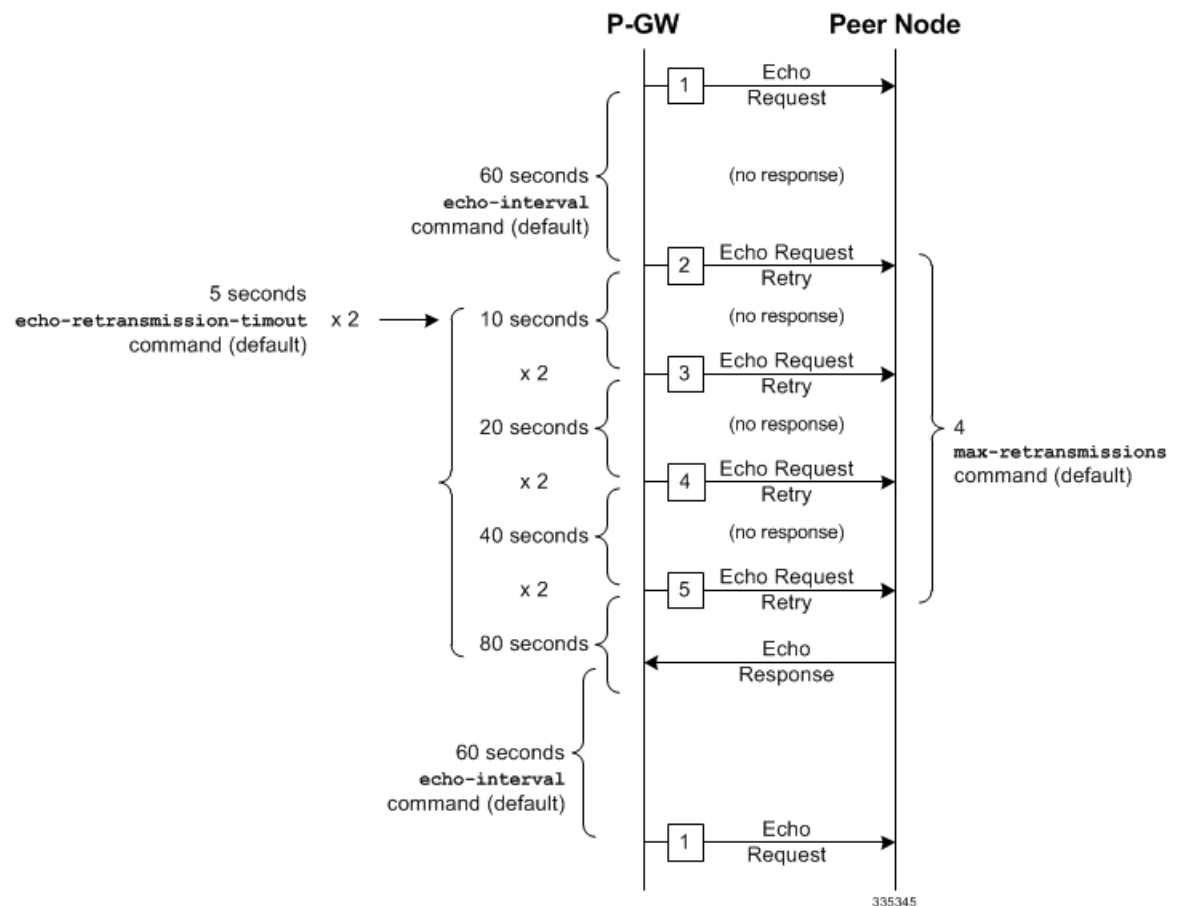

- The multiplier (x2) is system-coded and cannot be configured.

GTP-U

```

configure
  configure
    context <context_name>

```

```

gtpu-service <gtpu_service_name>
  echo-interval <seconds>
  echo-retransmission-timeout <seconds>
  max-retransmissions <num>
end

```

Notes:

- This configuration can be used in either the ingress context supporting the S1-U interfaces with the eNodeB and the egress context supporting the S5/S8 interface with the P-GW.
- Service names must be unique across all contexts within a chassis.
- The following diagram describes a failure and recovery scenario using default settings of the three GTP-U commands in the example above:

Figure 47: Failure and Recovery Scenario: Example 2

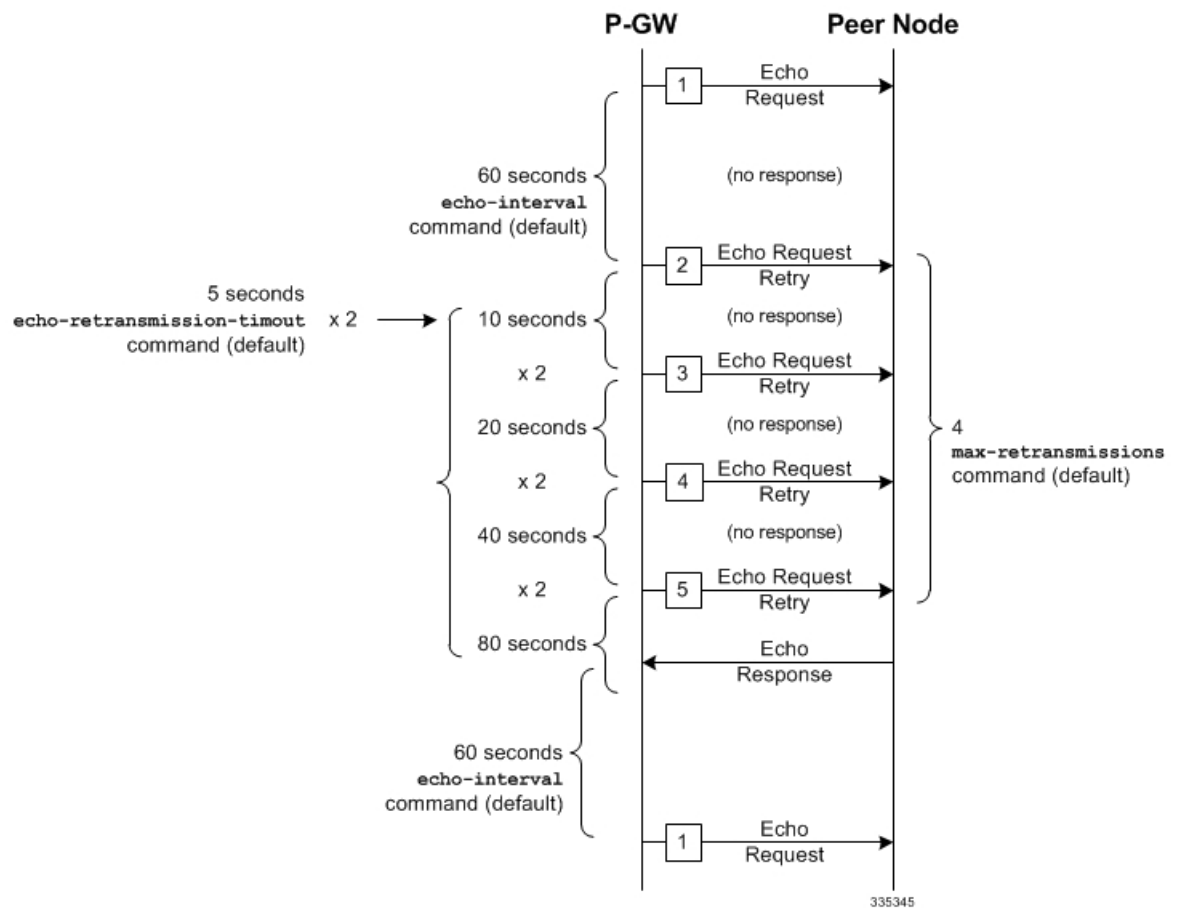

- The multiplier (x2) is system-coded and cannot be configured.

Dynamic GTP Echo Timer Configuration

The following examples describe the configuration of the dynamic eGTP-C and GTP-U interface echo timers:

eGTP-C

```
configure
  configure
    context <context_name>
      egtp-service <egtp_service_name>
        gtpc echo-interval <seconds> dynamic smooth-factor <multiplier>
        gtpc echo-retransmission-timeout <seconds>
        gtpc max-retransmissions <num>
      end
```

Notes:

- This configuration can be used in either the ingress context supporting the S1-U and/or S11 interfaces with the eNodeB and MME respectively; and the egress context supporting the S5/S8 interface with the P-GW.
- Service names must be unique across all contexts within a chassis.
- The following diagram describes a failure and recovery scenario using default settings of the three **gtpc** commands in the example above and an example round trip timer (RTT) of six seconds:

Figure 48: Failure and Recovery Scenario: Example 3

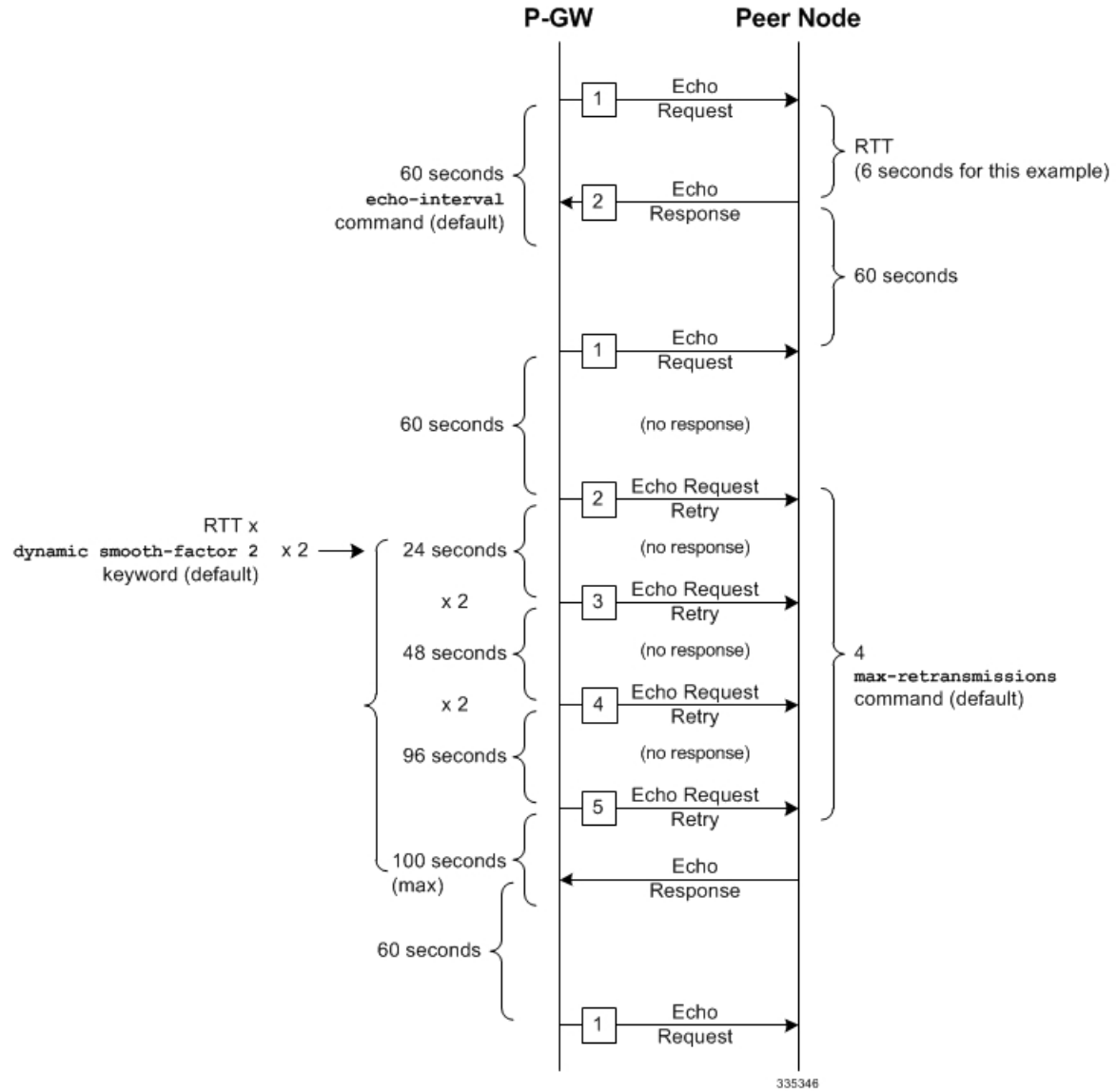

- The multiplier (x2) and the 100 second maximum are system-coded and cannot be configured.

GTP-U

```

configure
  configure
    context <context_name>
      gtpu-service <gtpu_service_name>
        echo-interval <seconds> dynamic smooth-factor <multiplier>
        echo-retransmission-timeout <seconds>
        max-retransmissions <num>
      end
    end
  end

```

Notes:

- This configuration can be used in either the ingress context supporting the S1-U interfaces with the eNodeB and the egress context supporting the S5/S8 interface with the P-GW.
- Service names must be unique across all contexts within a chassis.
- The following diagram describes a failure and recovery scenario using default settings of the three **gtpu** commands in the example above and an example round trip timer (RTT) of six seconds:

Figure 49: Failure and Recovery Scenario: Example 4

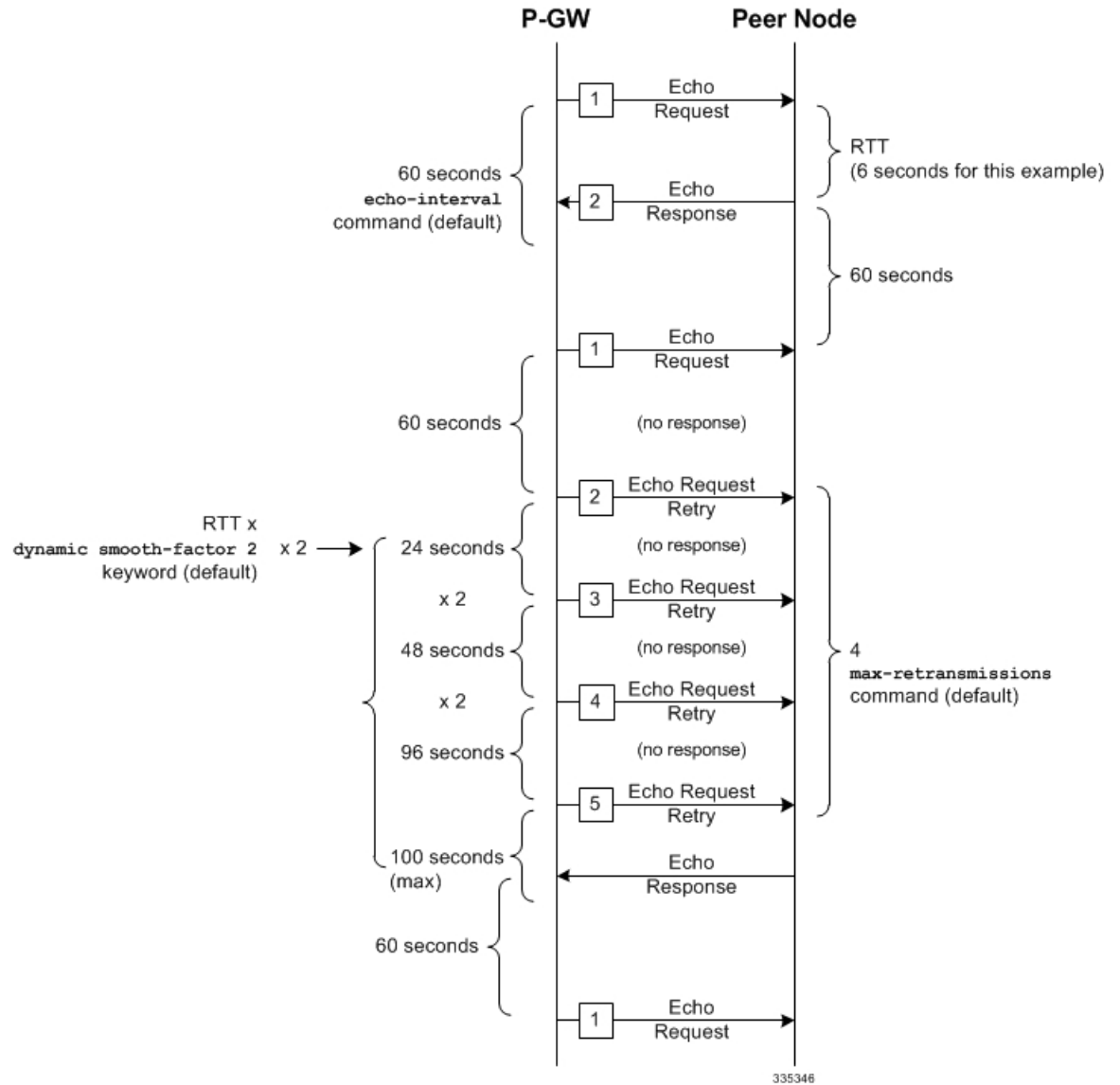

- The multiplier (x2) and the 100 second maximum are system-coded and cannot be configured.

Configuring GTPP Offline Accounting on the S-GW

By default the S-GW service supports GTPP accounting. To provide GTPP offline charging during, for example, scenarios where the foreign P-GW does not, configure the S-GW with the example parameters below:

```

configure
  gtp single-source
    context <saegw_context_name>
      subscriber default
        accounting mode gtp
        exit
      gtp group default
        gtp charging-agent address <gz_ipv4_address>
        gtp echo-interval <seconds>
        gtp attribute diagnostics
        gtp attribute local-record-sequence-number
        gtp attribute node-id-suffix <string>
        gtp dictionary <name>
        gtp server <ipv4_address> priority <num>
        gtp server <ipv4_address> priority <num> node-alive enable
        exit
      policy accounting <gz_policy_name>
        accounting-level {type}
        operator-string <string>
        cc profile <index> buckets <num>
        cc profile <index> interval <seconds>
        cc profile <index> volume total <octets>
        exit
      sgw-service <sgw_service_name>
        accounting context <saegw_context_name> gtp group default
        associate accounting-policy <gz_policy_name>
        exit
      exit
    context <saegw_context_name>
      interface <gz_interface_name>
        ip address <address>
        exit
      exit
    port ethernet <slot_number/port_number>
      no shutdown
      bind interface <gz_interface_name> <saegw_context_name>
    end
  
```

Notes:

- **gtp single-source** is enabled to allow the system to generate requests to the accounting server using a single UDP port (by way of a AAA proxy function) rather than each AAA manager generating requests on unique UDP ports.
- **gtp** is the default option for the **accounting mode** command.
- An accounting mode configured for the call-control profile will override this setting.

- **accounting-level** types are: flow, PDN, PDN-QCI, QCI, and subscriber. Refer to the Accounting Profile Configuration Mode Commands chapter in the *Command Line Interface Reference* for more information on this command.
- Service names must be unique across all contexts within a chassis.

Configuring Diameter Offline Accounting on the S-GW

By default the S-GW service supports GTPP accounting. You can enable accounting via RADIUS/Diameter (Rf) for the S-GW service. To provide Rf offline charging during, for example, scenarios where the foreign P-GW does not, configure the S-GW with the example parameters below:



Important In StarOS 19 and later versions, this feature is not supported on the S-GW.

```

configure
  operator-policy name <policy_name>
    associate call-control-profile <call_cntrl_profile_name>
    exit
  call-control-profile <call_cntrl_profile_name>
    accounting mode radius-diameter
    exit
  lte-policy
    subscriber-map <map_name>
    precedence <number> match-criteria all operator-policy-name
    <policy_name>
    exit
  exit
  context <saegw_context_name>
    policy accounting <rf_policy_name>
    accounting-level {type}
    operator-string <string>
    exit
    sgw-service <sgw_service_name>
    associate accounting-policy <rf_policy_name>
    associate subscriber-map <map_name>
    exit
    aaa group <rf-radius_group_name>
    radius attribute nas-identifier <id>
    radius accounting interim interval <seconds>
    radius dictionary <name>
    radius mediation-device accounting server <address> key <key>
    diameter authentication dictionary <name>
    diameter accounting dictionary <name>
    diameter accounting endpoint <rf_cfg_name>
    diameter accounting server <rf_cfg_name> priority <num>
    exit
  diameter endpoint <rf_cfg_name>
    use-proxy
    origin realm <realm_name>
    origin host <name> address <rf_ipv4_address>

```



```

peer <rf_cfg_name> realm <name> address <ofcs_ipv4_or_ipv6_addr>
route-entry peer <rf_cfg_name>
exit
exit
context <saegw_context_name>
interface <rf_interface_name>
ip address <rf_ipv4_address>
exit
exit
port ethernet <slot_number/port_number>
no shutdown
bind interface <rf_interface_name> <saegw_context_name>
end

```

Notes:

- **accounting-level** types are: flow, PDN, PDN-QCI, QCI, and subscriber. Refer to the Accounting Profile Configuration Mode Commands chapter in the *Command Line Interface Reference* for more information on this command.
- The Rf interface IP address can also be specified as an IPv6 address using the **ipv6 address** command.
- Service names must be unique across all contexts within a chassis.

Configuring APN-level Traffic Policing on the S-GW

To enable traffic policing for scenarios where the foreign subscriber's P-GW doesn't enforce it, use the following configuration example:

```

configure
apn-profile <apn_profile_name>
qos rate-limit downlink non-gbr-qci committed-auto-readjust duration
<seconds> exceed-action {action} violate-action {action}
qos rate-limit uplink non-gbr-qci committed-auto-readjust duration
<seconds> exceed-action {action} violate-action {action}
exit
operator-policy name <policy_name>
apn default-apn-profile <apn_profile_name>
exit
lte-policy
subscriber-map <map_name>
precedence <number> match-criteria all operator-policy-name
<policy_name>
exit
sgw-service <sgw_service_name>
associate subscriber-map <map_name>
end

```

Notes:

- For the **qos rate-limit** command, the actions supported for **violate-action** and **exceed-action** are: **drop**, **lower-ip-precedence**, and **transmit**.
- Service names must be unique across all contexts within a chassis.

Configuring X.509 Certificate-based Peer Authentication

The configuration example in this section enables X.509 certificate-based peer authentication, which can be used as the authentication method for IP Security on the S-GW.



Important Use of the IP Security feature requires that a valid license key be installed. Contact your local Sales or Support representative for information on how to obtain a license.

The following configuration example enables X.509 certificate-based peer authentication on the S-GW.

In Global Configuration Mode, specify the name of the X.509 certificate and CA certificate, as follows:

```
configure
  certificate name <cert_name> pem url <cert_pem_url> private-key pem url
  <private_key_url>
  ca-certificate name <ca_cert_name> pem url <ca_cert_url>
end
```

Notes:

- The **certificate name** and **ca-certificate list ca-cert-name** commands specify the X.509 certificate and CA certificate to be used.
- The PEM-formatted data for the certificate and CA certificate can be specified, or the information can be read from a file via a specified URL as shown in this example.

When creating the crypto template for IPsec in Context Configuration Mode, bind the X.509 certificate and CA certificate to the crypto template and enable X.509 certificate-based peer authentication for the local and remote nodes, as follows:

```
configure
  context <saegw_context_name>
    crypto template <crypto_template_name> ikev2-dynamic
      certificate name <cert_name>
      ca-certificate list ca-cert-name <ca_cert_name>
      authentication local certificate
      authentication remote certificate
    end
```

Notes:

- A maximum of sixteen certificates and sixteen CA certificates are supported per system. One certificate is supported per service, and a maximum of four CA certificates can be bound to one crypto template.
- The **certificate name** and **ca-certificate list ca-cert-name** commands bind the certificate and CA certificate to the crypto template.
- The **authentication local certificate** and **authentication remote certificate** commands enable X.509 certificate-based peer authentication for the local and remote nodes.
- Service names must be unique across all contexts within a chassis.

Configuring Dynamic Node-to-Node IP Security on the S1-U and S5 Interfaces

The configuration example in this section creates IPSec/IKEv2 dynamic node-to-node tunnel endpoints on the S1-U and S5 interfaces.



Important Use of the IP Security feature requires that a valid license key be installed. Contact your local Sales or Support representative for information on how to obtain a license.

The following configuration examples are included in this section:

- [Creating and Configuring an IPSec Transform Set, on page 179](#)
- [Creating and Configuring an IKEv2 Transform Set, on page 179](#)
- [Creating and Configuring a Crypto Template, on page 180](#)
- [Binding the S1-U and S5 IP Addresses to the Crypto Template, on page 180](#)

Creating and Configuring an IPSec Transform Set

The following example configures an IPSec transform set, which is used to define the security association that determines the protocols used to protect the data on the interface:

```
configure
context <saegw_context_name>
  ipsec transform-set <ipsec_transform-set_name>
    encryption aes-cbc-128
    group none
    hmac sha1-96
    mode tunnel
  end
```

Notes:

- The encryption algorithm, **aes-cbc-128**, or Advanced Encryption Standard Cipher Block Chaining, is the default algorithm for IPSec transform sets configured on the system.
- The **group none** command specifies that no crypto strength is included and that Perfect Forward Secrecy is disabled. This is the default setting for IPSec transform sets configured on the system.
- The **hmac** command configures the Encapsulating Security Payload (ESP) integrity algorithm. The **sha1-96** keyword uses a 160-bit secret key to produce a 160-bit authenticator value. This is the default setting for IPSec transform sets configured on the system.
- The **mode tunnel** command specifies that the entire packet is to be encapsulated by the IPSec header, including the IP header. This is the default setting for IPSec transform sets configured on the system.
- Service names must be unique across all contexts within a chassis.

Creating and Configuring an IKEv2 Transform Set

The following example configures an IKEv2 transform set:

```
configure
context <saegw_context_name>
  ikev2-ikesa transform-set <ikev2_transform-set_name>
```

```

encryption aes-cbc-128
group 2
hmac sha1-96
lifetime <sec>
prf sha1
end

```

Notes:

- The encryption algorithm, **aes-cbc-128**, or Advanced Encryption Standard Cipher Block Chaining, is the default algorithm for IKEv2 transform sets configured on the system.
- The **group 2** command specifies the Diffie-Hellman algorithm as Group 2, indicating medium security. The Diffie-Hellman algorithm controls the strength of the crypto exponentials. This is the default setting for IKEv2 transform sets configured on the system.
- The **hmac** command configures the Encapsulating Security Payload (ESP) integrity algorithm. The **sha1-96** keyword uses a 160-bit secret key to produce a 160-bit authenticator value. This is the default setting for IKEv2 transform sets configured on the system.
- The **lifetime** command configures the time the security key is allowed to exist, in seconds.
- The **prf** command configures the IKE Pseudo-random Function, which produces a string of bits that cannot be distinguished from a random bit string without knowledge of the secret key. The **sha1** keyword uses a 160-bit secret key to produce a 160-bit authenticator value. This is the default setting for IKEv2 transform sets configured on the system.
- Service names must be unique across all contexts within a chassis.

Creating and Configuring a Crypto Template

The following example configures an IKEv2 crypto template:

```

configure
context <saegw_context_name>
crypto template <crypto_template_name> ikev2-dynamic
ikev2-ikesa transform-set list <name1> . . . <name6>
ikev2-ikesa rekey
payload <name> match childsa match ipv4
ipsec transform-set list <name1> . . . <name4>
rekey
end

```

Notes:

- The **ikev2-ikesa transform-set list** command specifies up to six IKEv2 transform sets.
- The **ipsec transform-set list** command specifies up to four IPSec transform sets.
- Service names must be unique across all contexts within a chassis.

Binding the S1-U and S5 IP Addresses to the Crypto Template

The following example configures the binding of the S1-U and S5 interfaces to the crypto template.



Important If you modify the **interface-type** command, the parent service (service within which the eGTP/GTP-U service is configured) will automatically restart. Service restart results in dropping of active calls associated with the parent service.

configure

```

context <saegw_context_name>
  gtpu-service <gtpu_ingress_service_name>
    bind ipv4-address <s1-u_interface_ip_address> crypto-template
<enodeb_crypto_template>
    exit
  egtp-service <egtp_ingress_service_name>
    interface-type interface-sgw-ingress
    associate gtpu-service <gtpu_ingress_service_name>
    gtpc bind address <slu_interface_ip_address>
    exit
  exit
context <sgw_egress_context_name>
  gtpu-service <gtpu_egress_service_name>
    bind ipv4-address <s5_interface_ip_address> crypto-template
<enodeb_crypto_template>
    exit
  egtp-service <egtp_egress_service_name>
    interface-type interface-sgw-egress
    associate gtpu-service <gtpu_egress_service_name>
    gtpc bind address <s5_interface_ip_address>
    exit
  exit
context <saegw_context_name>
  sgw-service <sgw_service_name> -noconfirm
    egtp-service ingress service <egtp_ingress_service_name>
    egtp-service egress context <sgw_egress_context_name>
  end

```

Notes:

- The **bind** command in the GTP-U ingress and egress service configuration can also be specified as an IPv6 address using the **ipv6-address** command.
- Service names must be unique across all contexts within a chassis.

Configuring ACL-based Node-to-Node IP Security on the S1-U and S5 Interfaces

The configuration example in this section creates IKEv2/IPSec ACL-based node-to-node tunnel endpoints on the S1-U and S5 interfaces.



Important Use of the IP Security feature requires that a valid license key be installed. Contact your local Sales or Support representative for information on how to obtain a license.

The following configuration examples are included in this section:

- [Creating and Configuring a Crypto Access Control List, on page 182](#)
- [Creating and Configuring an IPSec Transform Set, on page 182](#)
- [Creating and Configuring an IKEv2 Transform Set, on page 183](#)
- [Creating and Configuring a Crypto Map, on page 183](#)

Creating and Configuring a Crypto Access Control List

The following example configures a crypto ACL (Access Control List), which defines the matching criteria used for routing subscriber data packets over an IPSec tunnel:

```
configure
  context <saegw_context_name>
    ip access-list <acl_name>
      permit tcp host <source_host_address> host <dest_host_address>
    end
```

Notes:

- The **permit** command in this example routes IPv4 traffic from the server with the specified source host IPv4 address to the server with the specified destination host IPv4 address.

Creating and Configuring an IPSec Transform Set

The following example configures an IPSec transform set which is used to define the security association that determines the protocols used to protect the data on the interface:

```
configure
  context <saegw_context_name>
    ipsec transform-set <ipsec_transform-set_name>
      encryption aes-cbc-128
      group none
      hmac sha1-96
      mode tunnel
    end
```

Notes:

- The encryption algorithm, **aes-cbc-128**, or Advanced Encryption Standard Cipher Block Chaining, is the default algorithm for IPSec transform sets configured on the system.
- The **group none** command specifies that no crypto strength is included and that Perfect Forward Secrecy is disabled. This is the default setting for IPSec transform sets configured on the system.
- The **hmac** command configures the Encapsulating Security Payload (ESP) integrity algorithm. The **sha1-96** keyword uses a 160-bit secret key to produce a 160-bit authenticator value. This is the default setting for IPSec transform sets configured on the system.
- The **mode tunnel** command specifies that the entire packet is to be encapsulated by the IPSec header including the IP header. This is the default setting for IPSec transform sets configured on the system.
- Service names must be unique across all contexts within a chassis.

Creating and Configuring an IKEv2 Transform Set

The following example configures an IKEv2 transform set:

```

configure
  context <saegw_context_name>
    ikev2-ikesa transform-set <ikev2_transform-set_name>
      encryption aes-cbc-128
      group 2
      hmac sha1-96
      lifetime <sec>
      prf sha1
    end

```

Notes:

- The encryption algorithm, **aes-cbc-128**, or Advanced Encryption Standard Cipher Block Chaining, is the default algorithm for IKEv2 transform sets configured on the system.
- The **group 2** command specifies the Diffie-Hellman algorithm as Group 2, indicating medium security. The Diffie-Hellman algorithm controls the strength of the crypto exponentials. This is the default setting for IKEv2 transform sets configured on the system.
- The **hmac** command configures the Encapsulating Security Payload (ESP) integrity algorithm. The **sha1-96** keyword uses a 160-bit secret key to produce a 160-bit authenticator value. This is the default setting for IKEv2 transform sets configured on the system.
- The **lifetime** command configures the time the security key is allowed to exist, in seconds.
- The **prf** command configures the IKE Pseudo-random Function which produces a string of bits that cannot be distinguished from a random bit string without knowledge of the secret key. The **sha1** keyword uses a 160-bit secret key to produce a 160-bit authenticator value. This is the default setting for IKEv2 transform sets configured on the system.
- Service names must be unique across all contexts within a chassis.

Creating and Configuring a Crypto Map

The following example configures an IKEv2 crypto map and applies it to the S1-U interface:

```

configure
  context <saegw_context_name>
    crypto map <crypto_map_name> ikev2-ipv4
      match address <acl_name>
      peer <ipv4_address>
      authentication local pre-shared-key key <text>
      authentication remote pre-shared-key key <text>
      ikev2-ikesa transform-set list <name1> . . . <name6>
      payload <name> match ipv4
      lifetime <seconds>
      ipsec transform-set list <name1> . . . <name4>
    exit
  exit
  interface <s1-u_intf_name>
    ip address <ipv4_address>

```

```

    crypto-map <crypto_map_name>
  exit
exit
port ethernet <slot_number/port_number>
  no shutdown
  bind interface <s1_u_intf_name> <saegw_context_name>
end

```

Notes:

- The type of crypto map used in this example is IKEv2-IPv4 for IPv4 addressing. An IKEv2-IPv6 crypto map can also be used for IPv6 addressing.
- The **ipsec transform-set list** command specifies up to four IPsec transform sets.
- Service names must be unique across all contexts within a chassis.

The following example configures an IKEv2 crypto map and applies it to the S5 interface:

```

configure
  context <sgw_egress_context_name>
    crypto map <crypto_map_name> ikev2-ipv4
      match address <acl_name>
      peer <ipv4_address>
      authentication local pre-shared-key key <text>
      authentication remote pre-shared-key key <text>
      payload <name> match ipv4
        lifetime <seconds>
        ipsec transform-set list <name1> . . . <name4>
      exit
    exit
  interface <s5_intf_name>
    ip address <ipv4_address>
    crypto map <crypto_map_name>
    exit
  exit
  port ethernet <slot_number/port_number>
    no shutdown
    bind interface <s5_intf_name> <sgw_egress_context_name>
  end

```

Notes:

- The type of crypto map used in this example is IKEv2-IPv4 for IPv4 addressing. An IKEv2-IPv6 crypto map can also be used for IPv6 addressing.
- The **ipsec transform-set list** command specifies up to four IPsec transform sets.
- Service names must be unique across all contexts within a chassis.

Configuring R12 Load Control Support

Load control enables a GTP-C entity (for example, an S-GW/P-GW) to send its load information to a GTP-C peer (e.g. an MME/SGSN, ePDG, TWAN) to adaptively balance the session load across entities supporting

the same function (for example, an S-GW cluster) according to their effective load. The load information reflects the operating status of the resources of the GTP-C entity.

Use the following example to configure this feature:

```

configure
  gtpc-load-control-profile profile_name
    inclusion-frequency advertisement-interval interval_in_seconds
    weightage system-cpu-utilization percentage system-memory-utilization
percentage license-session-utilization percentage
  end
configure
  context context_name
    sgw-service sgw_service_name
      associate gtpc-load-control-profile profile_name
    exit
    saegw-service saegw_service_name
      associate sgw-service sgw_service_name
    end

```

Notes:

- The **inclusion-frequency** parameter determines how often the Load control information element is sent to the peer(s).
- The total of the three **weightage** parameters should not exceed 100.
- The **associate** command is used to associate the Load Control Profile with an existing S-GW service and to associate the S-GW service with the SAEGW service.
- On the SAEGW, both the P-GW and S-GW should use the same Load Control profile.

Configuring R12 Overload Control Support

Overload control enables a GTP-C entity becoming or being overloaded to gracefully reduce its incoming signaling load by instructing its GTP-C peers to reduce sending traffic according to its available signaling capacity to successfully process the traffic. A GTP-C entity is in overload when it operates over its signaling capacity, which results in diminished performance (including impacts to handling of incoming and outgoing traffic).

Use the following example to configure this feature.

```

configure
  gtpc-overload-control-profile profile_name
    inclusion-frequency advertisement-interval interval_in_seconds
    weightage system-cpu-utilization percentage system-memory-utilization
percentage license-session-utilization percentage
    throttling-behavior emergency-events exclude
    tolerance initial-reduction-metric percentage
    tolerance threshold report-reduction-metric percentage
  self-protection-limit percentage
    validity-period seconds
  end
configure
  context context_name
    sgw-service sgw_service_name

```

```

    associate gtpc-overload-control-profile profile_name
    exit
  saegw-service saegw_service_name
    associate sgw-service sgw_service_name
  end

```

Notes:

- The **inclusion-frequency** parameter determines how often the Overload control information element is sent to the peer(s).
- The total of the three **weightage** parameters should not exceed 100.
- **validity-period** configures how long the overload control information is valid. Valid entries are from 1 to 3600 seconds. The default is 600 seconds.
- The **associate** command is used to associate the Overload Control Profile with an existing S-GW and SAEGW service.
- On the SAEGW, both the P-GW and S-GW should use the same Overload Control profile.

Configuring S4 SGSN Handover Capability

This configuration example configures an S4 interface supporting inter-RAT handovers between the S-GW and a S4 SGSN. Use the following example to configure this feature.



Important If you modify the **interface-type** command, the parent service (service within which the eGTP/GTP-U service is configured) will automatically restart. Service restart results in dropping of active calls associated with the parent service.

```

configure
  context <saegw_context_name> -noconfirm
    interface <s4_interface_name>
      ip address <ipv4_address_primary>
      ip address <ipv4_address_secondary>
    exit
  exit
  port ethernet <slot_number/port_number>
  no shutdown
  bind interface <s4_interface_name> <saegw_context_name>
  exit
  context <saegw_context_name> -noconfirm
    gtpu-service <s4_gtpu_ingress_service_name>
      bind ipv4-address <s4_interface_ip_address>
    exit
    egtp-service <s4_egtp_ingress_service_name>
      interface-type interface-sgw-ingress
      validation-mode default
      associate gtpu-service <s4_gtpu_ingress_service_name>
      gtpc bind address <s4_interface_ip_address>
    exit
  sgw-service <sgw_service_name> -noconfirm

```

```

associate ingress egtp-service <s4_egtp_ingress_service_name>
end

```

Notes:

- The S4 interface IP address(es) can also be specified as IPv6 addresses using the **ipv6 address** command.
- Service names must be unique across all contexts within a chassis.

Configuring an eGTP P-GW Service

This section provides a high-level series of steps and the associated configuration file examples for configuring the system to perform as an eGTP P-GW in a test environment. Information provided in this section includes the following:

- [Information Required, on page 187](#)
- [How This Configuration Works, on page 193](#)
- [eGTP P-GW Configuration, on page 195](#)
- [DHCP Service Creation, on page 206](#)
- [DHCPv6 Service Creation, on page 208](#)

Information Required

The following sections describe the minimum amount of information required to configure and make the P-GW operational on the network. To make the process more efficient, it is recommended that this information be available prior to configuring the system.

There are additional configuration parameters that are not described in this section. These parameters deal mostly with fine-tuning the operation of the P-GW in the network. Information on these parameters can be found in the appropriate sections of the *Command Line Interface Reference*.

Required P-GW Context Configuration Information

The following table lists the information that is required to configure the P-GW context on a P-GW.

Table 25: Required Information for P-GW (SAEGW) Context Configuration

Required Information	Description
P-GW context name	An identification string from 1 to 79 characters (alpha and/or numeric) by which the P-GW context will be recognized by the system. Important The P-GW service must reside within the SAEGW context, thus this would be the SAEGW context name.
Accounting policy name	An identification string from 1 to 63 characters (alpha and/or numeric) by which the accounting policy will be recognized by the system. The accounting policy is used to set parameters for the Rf (off-line charging) interface.

Required Information	Description
S5/S8 Interface Configuration (To/from S-GW)	
Interface name	An identification string between 1 and 79 characters (alpha and/or numeric) by which the interface will be recognized by the system. Multiple names are needed if multiple interfaces will be configured.
IP address and subnet	IPv4 or IPv6 addresses assigned to the interface. Multiple addresses and subnets are needed if multiple interfaces will be configured.
Physical port number	The physical port to which the interface will be bound. Ports are identified by the chassis slot number where the line card resides followed by the number of the physical connector on the card. For example, port 17/1 identifies connector number 1 on the card in slot 17. A single physical port can facilitate multiple interfaces.
Gateway IP address	Used when configuring static IP routes from the interface(s) to a specific network.
GTP-U Service Configuration	
GTP-U service name	An identification string from 1 to 63 characters (alpha and/or numeric) by which the GTP-U service will be recognized by the system.
IP address	S5/S8 interface IPv4 address.
P-GW Service Configuration	
P-GW service name	An identification string from 1 to 63 characters (alpha and/or numeric) by which the P-GW service will be recognized by the system. Multiple names are needed if multiple P-GW services will be used.
PLMN ID	MCC number: The mobile country code (MCC) portion of the PLMN's identifier (an integer value between 100 and 999). MNC number: The mobile network code (MNC) portion of the PLMN's identifier (a 2 or 3 digit integer value between 00 and 999).
eGTP Service Configuration	
eGTP Service Name	An identification string from 1 to 63 characters (alpha and/or numeric) by which the eGTP service will be recognized by the system.

Required PDN Context Configuration Information

The following table lists the information that is required to configure the PDN context on a P-GW.

Table 26: Required Information for PDN Context Configuration

Required Information	Description
PDN context name	An identification string from 1 to 79 characters (alpha and/or numeric) by which the PDN context is recognized by the system.
IP Address Pool Configuration	
IPv4 address pool name and range	An identification string between 1 and 31 characters (alpha and/or numeric) by which the IPv4 pool is recognized by the system. Multiple names are needed if multiple pools will be configured. A range of IPv4 addresses defined by a starting address and an ending address.
IPv6 address pool name and range	An identification string between 1 and 31 characters (alpha and/or numeric) by which the IPv6 pool is recognized by the system. Multiple names are needed if multiple pools will be configured. A range of IPv6 addresses defined by a starting address and an ending address.
Access Control List Configuration	
IPv4 access list name	An identification string between 1 and 47 characters (alpha and/or numeric) by which the IPv4 access list is recognized by the system. Multiple names are needed if multiple lists will be configured.
IPv6 access list name	An identification string between 1 and 79 characters (alpha and/or numeric) by which the IPv6 access list is recognized by the system. Multiple names are needed if multiple lists will be configured.
Deny/permit type	The types are: <ul style="list-style-type: none"> • any • by host IP address • by IP packets • by source ICMP packets • by source IP address masking • by TCP/UDP packets
Readdress or redirect type	The types are <ul style="list-style-type: none"> • readdress server • redirect context • redirect css delivery-sequence • redirect css service • redirect nexthop

Required Information	Description
SGi Interface Configuration (To/from IPv4 PDN)	
Interface name	An identification string between 1 and 79 characters (alpha and/or numeric) by which the interface is recognized by the system. Multiple names are needed if multiple interfaces will be configured.
IP address and subnet	IPv4 addresses assigned to the interface. Multiple addresses and subnets are needed if multiple interfaces will be configured.
Physical port number	The physical port to which the interface will be bound. Ports are identified by the chassis slot number where the line card resides followed by the number of the physical connector on the card. For example, port 17/1 identifies connector number 1 on the card in slot 17. A single physical port can facilitate multiple interfaces.
Gateway IP address	Used when configuring static IP routes from the interface(s) to a specific network.
SGi Interface Configuration (To/from IPv6 PDN)	
Interface name	An identification string between 1 and 79 characters (alpha and/or numeric) by which the interface is recognized by the system. Multiple names are needed if multiple interfaces will be configured.
IP address and subnet	IPv6 addresses assigned to the interface. Multiple addresses and subnets are needed if multiple interfaces will be configured.
Physical port number	The physical port to which the interface will be bound. Ports are identified by the chassis slot number where the line card resides followed by the number of the physical connector on the card. For example, port 17/1 identifies connector number 1 on the card in slot 17. A single physical port can facilitate multiple interfaces.
Gateway IP address	Used when configuring static IP routes from the interface(s) to a specific network.

Required AAA Context Configuration Information

The following table lists the information that is required to configure the AAA context on a P-GW.

Table 27: Required Information for AAA Context Configuration

Required Information	Description
Gx Interface Configuration (to PCRF)	

Required Information	Description
Interface name	An identification string between 1 and 79 characters (alpha and/or numeric) by which the interface is recognized by the system. Multiple names are needed if multiple interfaces will be configured.
IP address and subnet	IPv4 or IPv6 addresses assigned to the interface. Multiple addresses and subnets are needed if multiple interfaces will be configured.
Physical port number	The physical port to which the interface will be bound. Ports are identified by the chassis slot number where the line card resides followed by the number of the physical connector on the card. For example, port 17/1 identifies connector number 1 on the card in slot 17. A single physical port can facilitate multiple interfaces.
Gateway IP address	Used when configuring static IP routes from the interface(s) to a specific network.
Gx Diameter Endpoint Configuration	
End point name	An identification string from 1 to 63 characters (alpha and/or numeric) by which the Gx Diameter endpoint configuration is recognized by the system.
Origin realm name	An identification string between 1 through 127 characters. The realm is the Diameter identity. The originator's realm is present in all Diameter messages and is typically the company or service name.
Origin host name	An identification string from 1 to 255 characters (alpha and/or numeric) by which the Gx origin host is recognized by the system.
Origin host address	The IP address of the Gx interface.
Peer name	The Gx endpoint name described above.
Peer realm name	The Gx origin realm name described above.
Peer address and port number	The IP address and port number of the PCRF.
Route-entry peer	The Gx endpoint name described above.
Gy Interface Configuration (to on-line charging server)	
Interface name	An identification string between 1 and 79 characters (alpha and/or numeric) by which the interface is recognized by the system. Multiple names are needed if multiple interfaces will be configured.
IP address and subnet	IPv4 or IPv6 addresses assigned to the interface. Multiple addresses and subnets are needed if multiple interfaces will be configured.

Required Information	Description
Physical port number	The physical port to which the interface will be bound. Ports are identified by the chassis slot number where the line card resides followed by the number of the physical connector on the card. For example, port 17/1 identifies connector number 1 on the card in slot 17. A single physical port can facilitate multiple interfaces.
Gateway IP address	Used when configuring static IP routes from the interface(s) to a specific network.
Gy Diameter Endpoint Configuration	
End point name	An identification string from 1 to 63 characters (alpha and/or numeric) by which the Gy Diameter endpoint configuration is recognized by the system.
Origin realm name	An identification string between 1 through 127 characters. The realm is the Diameter identity. The originator's realm is present in all Diameter messages and is typically the company or service name.
Origin host name	An identification string from 1 to 255 characters (alpha and/or numeric) by which the Gy origin host is recognized by the system.
Origin host address	The IP address of the Gy interface.
Peer name	The Gy endpoint name described above.
Peer realm name	The Gy origin realm name described above.
Peer address and port number	The IP address and port number of the OCS.
Route-entry peer	The Gy endpoint name described above.
Gz Interface Configuration (to off-line charging server)	
Interface name	An identification string between 1 and 79 characters (alpha and/or numeric) by which the interface is recognized by the system. Multiple names are needed if multiple interfaces will be configured.
IP address and subnet	IPv4 addresses assigned to the interface. Multiple addresses and subnets are needed if multiple interfaces will be configured.
Physical port number	The physical port to which the interface will be bound. Ports are identified by the chassis slot number where the line card resides followed by the number of the physical connector on the card. For example, port 17/1 identifies connector number 1 on the card in slot 17. A single physical port can facilitate multiple interfaces.
Gateway IP address	Used when configuring static IP routes from the interface(s) to a specific network.
Rf Interface Configuration (to off-line charging server)	

Required Information	Description
Interface name	An identification string between 1 and 79 characters (alpha and/or numeric) by which the interface is recognized by the system. Multiple names are needed if multiple interfaces will be configured.
IP address and subnet	IPv4 or IPv6 addresses assigned to the interface. Multiple addresses and subnets are needed if multiple interfaces will be configured.
Physical port number	The physical port to which the interface will be bound. Ports are identified by the chassis slot number where the line card resides followed by the number of the physical connector on the card. For example, port 17/1 identifies connector number 1 on the card in slot 17. A single physical port can facilitate multiple interfaces.
Gateway IP address	Used when configuring static IP routes from the interface(s) to a specific network.
Rf Diameter Endpoint Configuration	
End point name	An identification string from 1 to 63 characters (alpha and/or numeric) by which the Rf Diameter endpoint configuration is recognized by the system.
Origin realm name	An identification string between 1 through 127 characters. The realm is the Diameter identity. The originator's realm is present in all Diameter messages and is typically the company or service name.
Origin host name	An identification string from 1 to 255 characters (alpha and/or numeric) by which the Rf origin host is recognized by the system.
Origin host address	The IP address of the Rf interface.
Peer name	The Rf endpoint name described above.
Peer realm name	The Rf origin realm name described above.
Peer address and port number	The IP address and port number of the OFCS.
Route-entry peer	The Rf endpoint name described above.

How This Configuration Works

The following figure and supporting text describe how this configuration with a single source and destination context is used by the system to process a subscriber call originating from the GTP LTE network.

Figure 50: SAEGW Configuration with Single Source and Destination Context Processing a Subscriber Call Originating from the GTP LTE Network

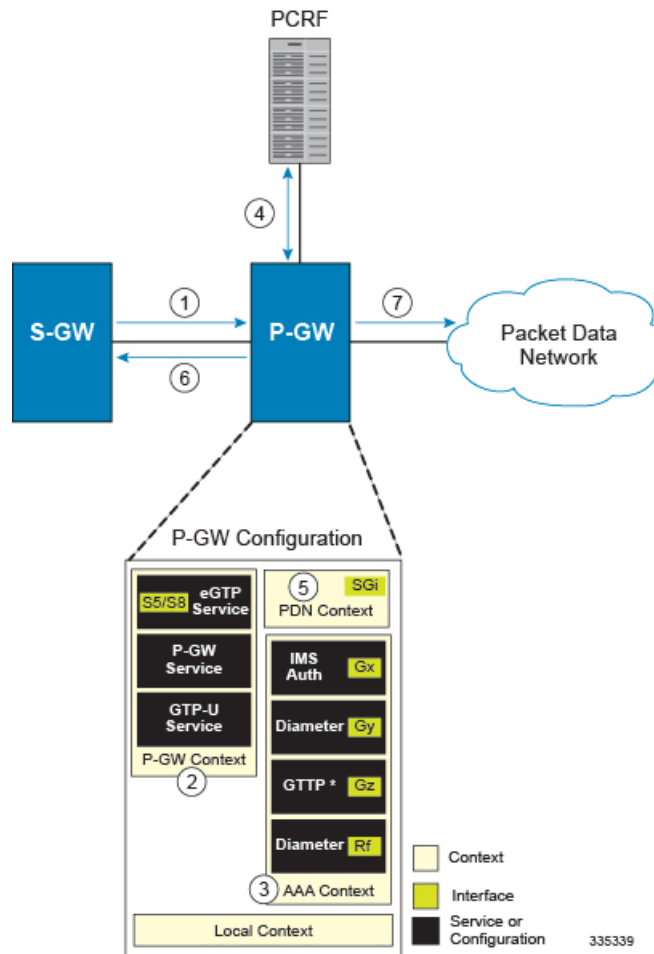

1. The S-GW establishes the S5/S8 connection by sending a Create Session Request message to the P-GW including an Access Point name (APN).
2. The P-GW service determines which context to use to provide AAA functionality for the session. This process is described in the *How the System Selects Contexts* section located in the *Understanding the System Operation and Configuration* chapter of the *System Administration Guide*.
3. The P-GW uses the configured Gx Diameter endpoint to establish the IP-CAN session.
4. The P-GW sends a CC-Request (CCR) message to the PCRF to indicate the establishment of the IP-CAN session and the PCRF acknowledges with a CC-Answer (CCA).
5. The P-GW uses the APN configuration to select the PDN context. IP addresses are assigned from the IP pool configured in the selected PDN context.
6. The P-GW responds to the S-GW with a Create Session Response message including the assigned address and additional information.
7. The S5/S8 data plane tunnel is established and the P-GW can forward and receive packets to/from the PDN.

eGTP P-GW Configuration

To configure the system to perform as an eGTP P-GW:

Figure 51: eGTP P-GW Configuration

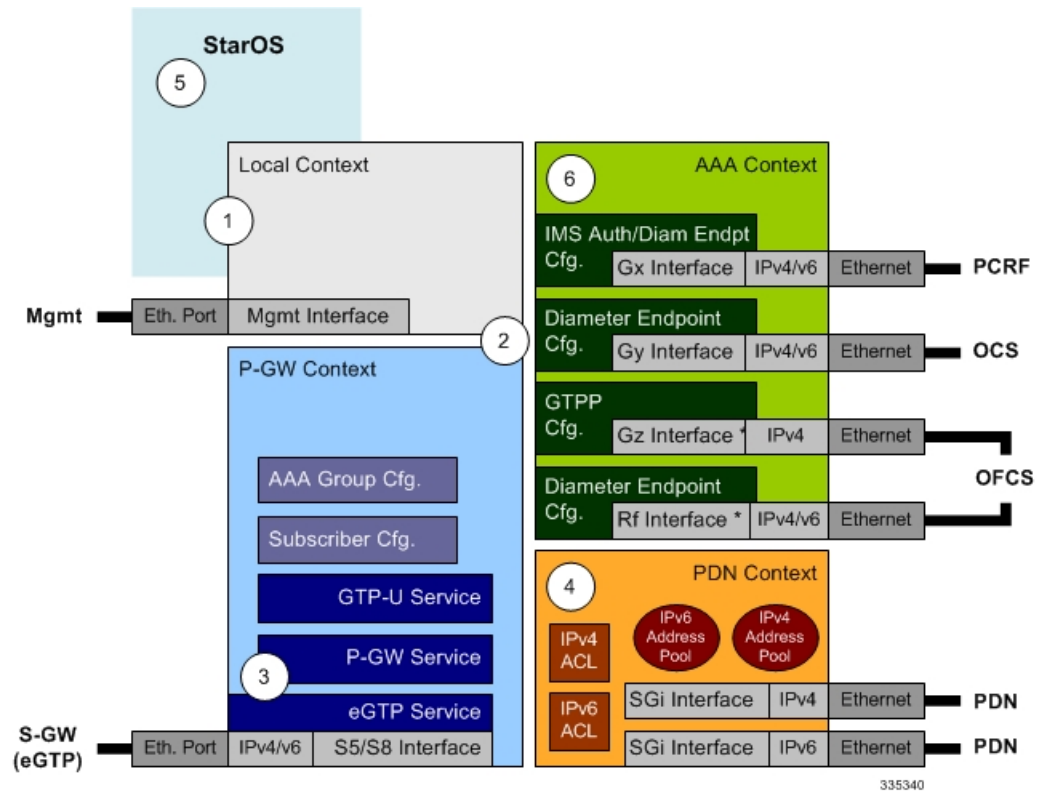

- Step 1** Set system configuration parameters such as activating PSCs by applying the example configurations found in the *System Administration Guide*.
- Step 2** Set initial configuration parameters such as creating contexts and services by applying the example configurations found in [Initial Configuration, on page 196](#).
- Step 3** Configure the system to perform as an eGTP P-GW and set basic P-GW parameters such as eGTP interfaces and IP routes by applying the example configurations presented in [P-GW Service Configuration, on page 200](#).
- Step 4** Configure the PDN context by applying the example configuration in [P-GW PDN Context Configuration, on page 200](#).
- Step 5** Enable and configure the active charging service for Gx interface support by applying the example configuration in [Active Charging Service Configuration, on page 201](#).
- Step 6** Create a AAA context and configure parameters for policy by applying the example configuration in [Policy Configuration, on page 203](#).
- Step 7** Verify and save the configuration by following the steps found in [Verifying and Saving the Configuration, on page 205](#).

Initial Configuration

-
- Step 1** Create the context where the eGTP service will reside by applying the example configuration in [Creating and Configuring an eGTP P-GW Context, on page 196](#).
 - Step 2** Create and configure APNs in the P-GW context by applying the example configuration in [Creating and Configuring APNs in the P-GW Context, on page 197](#).
 - Step 3** Create and configure AAA server groups in the P-GW context by applying the example configuration in [Creating and Configuring AAA Groups in the P-GW Context, on page 198](#).
 - Step 4** Create an eGTP service within the newly created context by applying the example configuration in [Creating and Configuring an eGTP Service, on page 198](#).
 - Step 5** Create and configure a GTP-U service within the P-GW context by applying the example configuration in [Creating and Configuring a GTP-U Service, on page 199](#).
 - Step 6** Create a context through which the interface to the PDN will reside by applying the example configuration in [Creating a P-GW PDN Context, on page 199](#).
-

Creating and Configuring an eGTP P-GW Context

Use the following example to create a P-GW context, create an S5/S8 IPv4 interface (for data traffic to/from the S-GW), and bind the S5/S8 interface to a configured Ethernet port:

```

configure
  gtp single-source
  context <saegw_context_name> -noconfirm
    interface <s5s8_interface_name>
      ip address <ipv4_address>
      exit
    gtp group default
      gtp charging-agent address <gz_ipv4_address>
      gtp echo-interval <seconds>
      gtp attribute diagnostics
      gtp attribute local-record-sequence-number
      gtp attribute node-id-suffix <string>
      gtp dictionary <name>
      gtp server <ipv4_address> priority <num>
      gtp server <ipv4_address> priority <num> node-alive enable
      exit
    policy accounting <rf_policy_name> -noconfirm
      accounting-level {level_type}
      accounting-event-trigger interim-timeout action stop-start
      operator-string <string>
      cc profile <index> interval <seconds>
      exit
    exit
  subscriber default
  exit
  port ethernet <slot_number/port_number>
  no shutdown

```

```

bind interface <s5s8_interface_name> <saegw_context_name>
end

```

Notes:

- **gtpp single-source** is enabled to allow the system to generate requests to the accounting server using a single UDP port (by way of a AAA proxy function) rather than each AAA manager generating requests on unique UDP ports.
- The S5/S8 (P-GW to S-GW) interface IP address can also be specified as an IPv6 address using the **ipv6 address** command.
- Set the accounting policy for the Rf (off-line charging) interface. The accounting level types are: flow, PDN, PDN-QCI, QCI, and subscriber. Refer to the *Accounting Profile Configuration Mode Commands* chapter in the *Command Line Interface Reference* for more information on this command.
- Set the GTPP group setting for Gz accounting.
- Service names must be unique across all contexts within a chassis.

Creating and Configuring APNs in the P-GW Context

Use the following configuration to create an APN:

```

configure
context <saegw_context_name> -noconfirm
  apn <name>
    accounting-mode radius-diameter
    associate accounting-policy <rf_policy_name>
    ims-auth-service <gx_ims_service_name>
    aaa group <rf-radius_group_name>
    dns primary <ipv4_address>
    dns secondary <ipv4_address>
    ip access-group <name> in
    ip access-group <name> out
    mediation-device context-name <saegw_context_name>
    ip context-name <pdn_context_name>
    ipv6 access-group <name> in
    ipv6 access-group <name> out
    active-charging rulebase <name>
  end

```

Notes:

- The IMS Authorization Service is created and configured in the AAA context.
- Multiple APNs can be configured to support different domain names.
- The associate accounting-policy command is used to associate a pre-configured accounting policy with this APN. Accounting policies are configured in the P-GW context. An example is located in [Creating and Configuring an eGTP P-GW Context, on page 196](#).
- Service names must be unique across all contexts within a chassis.

Use the following configuration to create an APN that includes Gz interface parameters:

```

configure
context <saegw_context_name> -noconfirm

```

```

apn <name>
  bearer-control-mode mixed
  selection-mode sent-by-ms
  accounting-mode gtp
  gtp group default accounting-context <aaa_context_name>
  ims-auth-service <gx_ims_service_name>
  ip access-group <name> in
  ip access-group <name> out
  ip context-name <pdn_context_name>
  active-charging rulebase <gz_rulebase_name>
end

```

Notes:

- The IMS Authorization Service is created and configured in the AAA context.
- Multiple APNs can be configured to support different domain names.
- The accounting-mode GTP and GTP group commands configure this APN for Gz accounting.
- Service names must be unique across all contexts within a chassis.

Creating and Configuring AAA Groups in the P-GW Context

Use the following example to create and configure AAA groups supporting RADIUS and Rf accounting:

```

configure
context <saegw_context_name> -noconfirm
  aaa group <rf-radius_group_name>
    radius attribute nas-identifier <id>
    radius accounting interim interval <seconds>
    radius dictionary <name>
    radius mediation-device accounting server <address> key <key>
    diameter authentication dictionary <name>
    diameter accounting dictionary <name>
    diameter accounting endpoint <rf_cfg_name>
    diameter accounting server <rf_cfg_name> priority <num>
  exit
  aaa group default
    radius attribute nas-ip-address address <ipv4_address>
    radius accounting interim interval <seconds>
    diameter authentication dictionary <name>
    diameter accounting dictionary <name>
    diameter accounting endpoint <rf_cfg_name>
    diameter accounting server <rf_cfg_name> priority <num>
  end

```

Notes:

- Service names must be unique across all contexts within a chassis.

Creating and Configuring an eGTP Service

Use the following configuration example to create the eGTP service.



Important If you modify the **interface-type** command, the parent service (service within which the eGTP/GTP-U service is configured) will automatically restart. Service restart results in dropping of active calls associated with the parent service.

configure

```
context <saegw_context_name>
  egtp-service <egtp_service_name> -noconfirm
  interface-type interface-pgw-ingress
  validation mode default
  associate gtpu-service <gtpu_service_name>
  gtpc bind address <s5s8_interface_address>
end
```

Notes:

- Co-locating a GGSN service on the same ASR 5500 requires that the **gtpc bind address** command uses the same IP address that the GGSN service is bound to.
- Service names must be unique across all contexts within a chassis.

Creating and Configuring a GTP-U Service

Use the following configuration example to create the GTP-U service:

configure

```
context <saegw_context_name>
  gtpu-service <gtpu_service_name> -noconfirm
  bind ipv4-address <s5s8_interface_address>
end
```

Notes:

- The **bind** command can also be specified as an IPv6 address using the **ipv6-address** command.
- Service names must be unique across all contexts within a chassis.

Creating a P-GW PDN Context

Use the following example to create a P-GW PDN context and Ethernet interface, and bind the interface to a configured Ethernet port.

configure

```
context <pdn_context_name> -noconfirm
  interface <sgi_ipv4_interface_name>
  ip address <ipv4_address>
  exit
  interface <sgi_ipv6_interface_name>
  ipv6 address <address>
end
```

Notes:

- Service names must be unique across all contexts within a chassis.

P-GW Service Configuration

- Step 1** Configure the P-GW service by applying the example configuration in [Configuring the P-GW Service, on page 200](#).
- Step 2** Specify an IP route to the eGTP Serving Gateway by applying the example configuration in [Configuring a Static IP Route, on page 200](#).

Configuring the P-GW Service

Use the following example to configure the P-GW service:

```
configure
context <saegw_context_name>
  pgw-service <pgw_service_name> -noconfirm
  plmn id mcc <id> mnc <id>
  associate egtp-service <egtp_service_name>
  associate qci-qos-mapping <name>
end
```

Notes:

- QCI-QoS mapping configurations are created in the AAA context. Refer to [Configuring QCI-QoS Mapping, on page 205](#).
- Co-locating a GGSN service on the same ASR 5500 requires the configuration of the **associate ggsn-service name** command within the P-GW service.
- Service names must be unique across all contexts within a chassis.

Configuring a Static IP Route

Use the following example to configure an IP Route for control and user plane data communication with an eGTP Serving Gateway:

```
configure
context <saegw_context_name>
  ip route <sgw_ip_addr/mask> <sgw_next_hop_addr> <pgw_intrfc_name>
end
```

Notes:

- Service names must be unique across all contexts within a chassis.

P-GW PDN Context Configuration

Use the following example to configure an IP Pool and APN, and bind a port to the interface in the PDN context:

```
configure
context <pdn_context_name> -noconfirm
  interface <sgi_ipv4_interface_name>
    ip address <ipv4_address>
  exit
  interface <sgi_ipv6_interface_name>
    ip address <ipv6_address>
```



```

    exit
ip pool <name> range <start_address end_address> public <priority>
ipv6 pool <name> range <start_address end_address> public <priority>
subscriber default
exit
ip access-list <name>
    redirect css service <name> any
    permit any
    exit
ipv6 access-list <name>
    redirect css service <name> any
    permit any
    exit
aaa group default
exit
exit
port ethernet <slot_number/port_number>
    no shutdown
    bind interface <sgi_ipv4_interface_name> <pdn_context_name>
    exit
port ethernet <slot_number/port_number>
    no shutdown
    bind interface <sgi_ipv6_interface_name> <pdn_context_name>
end

```

Notes:

- Service names must be unique across all contexts within a chassis.

Active Charging Service Configuration

Use the following example to enable and configure active charging:

```

configure
require active-charging optimized-mode
active-charging service <name>
    ruledef <name>
        <rule_definition>
        .
        <rule_definition>
    exit
ruledef default
    ip any-match = TRUE
    exit
ruledef icmp-pkts
    icmp any-match = TRUE
    exit
ruledef qci3
    icmp any-match = TRUE
    exit
ruledef static
    icmp any-match = TRUE
    exit

```

```

charging-action <name>
  <action>
  .
  <action>
  exit
charging-action icmp
  billing-action egcdr
  exit
charging-action qci3
  content-id <id>
  billing-action egcdr
  qos-class-identifier <id>
  allocation-retention-priority <priority>
  tft-packet-filter qci3
  exit
charging-action static
  service-identifier <id>
  billing-action egcdr
  qos-class-identifier <id>
  allocation-retention-priority <priority>
  tft-packet-filter qci3
  exit
packet-filter <packet_filter_name>
  ip remote address = { ipv4/ipv6_address | ipv4/ipv6_address/mask }
  ip remote-port = { port_number | range start_port_number to end_port_number
}

  exit
  rulebase default
  exit
rulebase <name>
  <rule_base>
  .
  <rule_base>
  exit
rulebase <gx_rulebase_name>
  dynamic-rule order first-if-tied
  egcdr tariff minute <minute> hour <hour>(optional)
  billing-records egcdr
  action priority 5 dynamic-only ruledef qci3 charging-action qci3
  action priority 100 ruledef static charging-action static
  action priority 500 ruledef default charging-action icmp
  action priority 570 ruledef icmp-pkts charging-action icmp
  egcdr threshold interval <interval>
  egcdr threshold volume total <bytes>
end

```

Notes:

- A rule base is a collection of rule definitions and associated charging actions.
- As depicted above, multiple rule definitions, charging actions, and rule bases can be configured to support a variety of charging scenarios.

- Charging actions define the action to take when a rule definition is matched.
- Routing and/or charging rule definitions can be created/configured. The maximum number of routing rule definitions that can be created is 256. The maximum number of charging rule definitions is 2048.
- The billing-action `egcdr` command in the charging-action `qc13`, `icmp`, and `static` examples is required for Gz accounting.
- The Gz rulebase example supports the Gz interface for off-line charging. The **billing-records egcdr** command is required for Gz accounting. All other commands are optional.
- Service names must be unique across all contexts within a chassis.



Important If an uplink packet is coming on the dedicated bearer, only rules installed on the dedicated bearer are matched. Static rules are not matched and packets failing to match the same will be dropped.



Important After you configure **configure**, **require active-charging optimized-mode**, **active-charging service** `<name>`, **ruledef** `<name>`, and `<rule_definition>` CLI commands, you must save the configuration and then reload the chassis for the command to take effect. For information on saving the configuration file and reloading the chassis, refer to the *System Administration Guide* for your deployment.

Policy Configuration

-
- Step 1** Configure the policy and accounting interfaces by applying the example configuration in [Creating and Configuring the AAA Context, on page 203](#).
- Step 2** Create and configure QCI to QoS mapping by applying the example configuration in [Configuring QCI-QoS Mapping, on page 205](#).
-

Creating and Configuring the AAA Context

Use the following example to create and configure a AAA context including diameter support and policy control, and bind Ethernet ports to interfaces supporting traffic between this context and a PCRF, an OCS, and an OFCS:

```
configure
context <aaa_context_name> -noconfirm
  interface <gx_interface_name>
    ipv6 address <address>
  exit
  interface <gy_interface_name>
    ipv6 address <address>
  exit
  interface <qz_interface_name>
    ip address <ipv4_address>
  exit
  interface <rf_interface_name>
```

```

    ip address <ipv4_address>
    exit
subscriber default
    exit
ims-auth-service <gx_ims_service_name>
    p-cscf discovery table <> algorithm round-robin
    p-cscf table <#> row-precedence <> ipv6-address <pcrf_ipv6_addr>
    policy-control
        diameter origin endpoint <gx_cfg_name>
        diameter dictionary <name>
        diameter host-select table <> algorithm round-robin
        diameter host-select row-precedence <> table <> host <gx_cfg_name>
    exit
    exit
diameter endpoint <gx_cfg_name>
    origin realm <realm_name>
    origin host <name> address <aaa_ctx_ipv6_address>
    peer <gx_cfg_name> realm <name> address <pcrf_ipv4_or_ipv6_addr>
    route-entry peer <gx_cfg_name>
    exit
diameter endpoint <gy_cfg_name>
    origin realm <realm_name>
    origin host <name> address <gy_ipv6_address>
    connection retry-timeout <seconds>
    peer <gy_cfg_name> realm <name> address <ocs_ipv4_or_ipv6_addr>
    route-entry peer <gy_cfg_name>
    exit
diameter endpoint <rf_cfg_name>
    use-proxy
    origin realm <realm_name>
    origin host <name> address <rf_ipv4_address>
    peer <rf_cfg_name> realm <name> address <ofcs_ipv4_or_ipv6_addr>
    route-entry peer <rf_cfg_name>
    exit
    exit
port ethernet <slot_number/port_number>
    no shutdown
    bind interface <gx_interface_name> <aaa_context_name>
    exit
port ethernet <slot_number/port_number>
    no shutdown
    bind interface <gy_interface_name> <aaa_context_name>
    exit
port ethernet <slot_number/port_number>
    no shutdown
    bind interface <gz_interface_name> <aaa_context_name>
    exit
port ethernet <slot_number/port_number>
    no shutdown
    bind interface <rf_interface_name> <aaa_context_name>
    end

```

Notes:

- The **p-cscf table** command under **ims-auth-service** can also specify an IPv4 address to the PCRF.
- The Gx interface IP address can also be specified as an IPv4 address using the **ip address** command.
- The Gy interface IP address can also be specified as an IPv4 address using the **ip address** command.
- The Rf interface IP address can also be specified as an IPv6 address using the **ipv6 address** command.
- Service names must be unique across all contexts within a chassis.

Configuring QCI-QoS Mapping

Use the following example to create and map QCI values to enforceable QoS parameters:

```
configure
qci-qos-mapping <name>
  qci 1 user-datagram dscp-marking <hex>
  qci 3 user-datagram dscp-marking <hex>
  qci 9 user-datagram dscp-marking <hex>
end
```

Notes:

- The SAEGW does not support non-standard QCI values. QCI values 1 through 9 are standard values and are defined in 3GPP TS 23.203; the SAEGW supports these standard values.
- The above configuration only shows one keyword example. Refer to the *QCI - QoS Mapping Configuration Mode Commands* chapter in the *Command Line Interface Reference* for more information on the **qci** command and other supported keywords.

Verifying and Saving the Configuration

Save your configuration to flash memory, an external memory device, and/or a network location using the Exec mode command **save configuration**. For additional information on how to verify and save configuration files, refer to the *System Administration Guide* and the *Command Line Interface Reference*.

DHCP Service Configuration

The system can be configured to use the Dynamic Host Control Protocol (DHCP) to assign IP addresses for PDP contexts. IP address assignment using DHCP is done using the following method, as configured within an APN:

DHCP-proxy: The system acts as a proxy for client (MS) and initiates the DHCP Discovery Request on behalf of client (MS). Once it receives an allocated IP address from DHCP server in response to DHCP Discovery Request, it assigns the received IP address to the MS. This allocated address must be matched with the an address configured in an IP address pool on the system. This complete procedure is not visible to MS.

As the number of addresses in memory decreases, the system solicits additional addresses from the DHCP server. If the number of addresses stored in memory rises above the configured limit, they are released back to the DHCP server.

There are parameters that must first be configured that specify the DHCP servers to communicate with and how the IP address are handled. These parameters are configured as part of a DHCP service.



Important This section provides the minimum instruction set for configuring a DHCP service on system for DHCP-based IP allocation. For more information on commands that configure additional DHCP server parameters and working of these commands, refer to the *DHCP Service Configuration Mode Commands* chapter of *Command Line Interface Reference*.

These instructions assume that you have already configured the system level configuration as described in *System Administration Guide* and P-GW service as described in *eGTP P-GW Configuration* section of this chapter.

To configure the DHCP service:

-
- Step 1** Create the DHCP service in system context and bind it by applying the example configuration in [DHCP Service Creation, on page 206](#).
 - Step 2** Configure the DHCP servers and minimum and maximum allowable lease times that are accepted in responses from DHCP servers by applying the example configuration in [DHCP Server Parameter Configuration, on page 206](#).
 - Step 3** Verify your DHCP Service configuration by following the steps in [DHCP Service Configuration Verification, on page 207](#).
 - Step 4** Save your configuration as described in the *Verifying and Saving Your Configuration* chapter.
-

DHCP Service Creation

Use the following example to create the DHCP service to support DHCP-based address assignment:

```
configure
  context <dest_ctxt_name>
    dhcp-service <dhcp_svc_name>
      bind address <ip_address> [ nexthop-forwarding-address <nexthop_ip_address>
[ mpls-label input <in_mpls_label_value> output <out_mpls_label_value1>
[ out_mpls_label_value2 ] ] ]
    end
```

Notes:

- To ensure proper operation, DHCP functionality should be configured within a destination context.
- Optional keyword **nexthop-forwarding-address** <nexthop_ip_address> **[mpls-label input** <in_mpls_label_value> **output** <out_mpls_label_value1> **[out_mpls_label_value2]]** applies DHCP over MPLS traffic.
- Service names must be unique across all contexts within a chassis.

DHCP Server Parameter Configuration

Use the following example to configure the DHCP server parameters to support DHCP-based address assignment:

```
configure
  context <dest_ctxt_name>
    dhcp-service <dhcp_svc_name>
```

```

dhcp server <ip_address> [ priority <priority> ]
dhcp server selection-algorithm {first-server | round-robin}
lease-duration min <minimum_dur> max <max_dur>
dhcp deadtime <max_time>
dhcp detect-dead-server consecutive-failures <max_number>
max-retransmissions <max_number>
retransmission-timeout <dur_sec>
end

```

Notes:

- Multiple DHCP can be configured by entering **dhcp server** command multiple times. A maximum of 20 DHCP servers can be configured.
- The **dhcp detect-dead-server** command and **max-retransmissions** command work in conjunction with each other.
- The retransmission-timeout command works in conjunction with **max-retransmissions** command.
- Service names must be unique across all contexts within a chassis.

DHCP Service Configuration Verification

Step 1 Verify that your DHCP servers configured properly by entering the following command in Exec Mode:

```
show dhcp service all
```

This command produces an output similar to that displayed below where DHCP name is *dhcp1*:

```

Service name:                dhcp1
Context:                     isp
Bind:                        Done
Local IP Address:           150.150.150.150
Next Hop Address:           192.179.91.3
    MPLS-label:
        Input:               5000
        Output:              1566    1899
Service Status:             Started
Retransmission Timeout:     3000 (milli-secs)
Max Retransmissions:        2
Lease Time:                 600 (secs)
Minimum Lease Duration:     600 (secs)
Maximum Lease Duration:     86400 (secs)
DHCP Dead Time:             120 (secs)
DHCP Dead consecutive Failure:5
DHCP T1 Threshold Timer:    50
DHCP T2 Threshold Timer:    88
DHCP Client Identifier:     Not Used
DHCP Algorithm:             Round Robin
DHCP Servers configured:
Address: 150.150.150.150    Priority: 1
DHCP server rapid-commit:   disabled
DHCP client rapid-commit:   disabled
DHCP chaddr validation:     enabled

```

Step 2 Verify the DHCP service status by entering the following command in Exec Mode:

```
show dhcp service status
```

DHCPv6 Service Configuration

The system can be configured to use the Dynamic Host Control Protocol (DHCP) for IPv6 to enable the DHCP servers to pass the configuration parameters such as IPv6 network addresses to IPv6 nodes. DHCPv6 configuration is done within an APN.

These instructions assume that you have already configured the system level configuration as described in *System Administration Guide* and APN as described in *P-GW PDN Context Configuration* section of this chapter.

To configure the DHCPv6 service:

-
- Step 1** Create the DHCPv6 service in system context and bind it by applying the example configuration in [DHCPv6 Service Creation, on page 208](#).
 - Step 2** Configure the DHCPv6 server and other configurable values for Renew Time, Rebind Time, Preferred Lifetime, and Valid Lifetime by applying the example configuration in [DHCPv6 Server Parameter Configuration, on page 209](#).
 - Step 3** Configure the DHCPv6 client and other configurable values for Maximum Retransmissions, Server Dead Tries, and Server Resurrect Time by applying the example configuration in [DHCPv6 Client Parameter Configuration, on page 209](#).
 - Step 4** Configure the DHCPv6 profile by applying the example configuration in the *DHCPv6 Profile Configuration* section.
 - Step 5** Associate the DHCPv6 profile configuration with the APN by applying the example configuration in [Associate DHCPv6 Configuration, on page 211](#).
 - Step 6** Verify your DHCPv6 Service configuration by following the steps in [Associate DHCPv6 Configuration, on page 211](#).
 - Step 7** Save your configuration as described in the *Verifying and Saving Your Configuration* chapter.
-

DHCPv6 Service Creation

Use the following example to create the DHCPv6 service to support DHCP-based address assignment:

```
configure
  context <dest_ctxt_name>
    dhcpv6-service <dhcpv6_svc_name>
      bind address <ipv6_address> port <port>
    end
```

Notes:

- To ensure proper operation, DHCPv6 functionality should be configured within a destination context.
- The Port specifies the listen port and is used to start the DHCPv6 server bound to it. It is optional and if unspecified, the default port is 547.
- Service names must be unique across all contexts within a chassis.

DHCPv6 Server Parameter Configuration

Use the following example to configure the DHCPv6 server parameters to support DHCPv6-based address assignment:

```

configure
  context <dest_ctxt_name>
    dhcpv6-service <dhcpv6_svc_name>
      dhcpv6-server
        renew-time <renewal_time>
        rebind-time <rebind_time>
        preferred-lifetime <pref_lifetime>
        valid-lifetime <valid_lifetime>
      end
    end

```

Notes:

- Multiple DHCP can be configured by entering **dhcp server** command multiple times. A maximum of 256 services (regardless of type) can be configured per system.
- **renew-time** configures the renewal time for prefixes assigned by dhcp-service. Default is 900 seconds.
- **rebind-time** configures the rebind time for prefixes assigned by dhcp-service. Default is 900 seconds.
- **preferred-lifetime** configures the preferred lifetime for prefixes assigned by dhcp-service. Default is 900 seconds.
- **valid-lifetime** configures the valid lifetime for prefixes assigned by dhcp-service. Default is 900 seconds.
- Service names must be unique across all contexts within a chassis.

DHCPv6 Client Parameter Configuration

Use the following example to configure the DHCPv6 client parameters to support DHCPv6-based address assignment:

```

configure
  context <dest_ctxt_name>
    dhcpv6-service <dhcpv6_svc_name>
      dhcpv6-client
        server-ipv6-address <ipv6_addr> port <port> priority <priority>
        max-retransmissions <max_number>
        server-dead-time <dead_time>
        server-resurrect-time <revive_time>
      end
    end

```

Notes:

- DHCPv6 client configuration requires an IPv6 address, port, and priority. The port is used for communicating with the DHCPv6 server. If not specified, default port 547 is used. The Priority parameter defines the priority in which servers should be tried out.
- **max-retransmissions** configures the max retransmission that DHCPV6-CLIENT will make towards DHCPV6-SERVER. Default is 20.
- **server-dead-time**: PDN DHCPV6-SERVER is considered to be dead if it does not respond after given tries from client. Default is 5.

- **server-resurrect-time:** PDN DHCPV6-SERVER is considered alive after it has been dead for given seconds. Default is 20.
- Service names must be unique across all contexts within a chassis.

DHCPv6 Profile Configuration

Use the following example to configure the DHCPv6 profile:

```

configure
  context <dest_ctxt_name>
    dhcp-server-profile <server_profile>
      enable rapid-commit-dhcpv6
      process dhcp-option-from { AAA | LOCAL | PDN-DHCP } priority
<priority>
      dhcpv6-server-preference <pref_value>
      enable dhcpv6-server-unicast
      enable dhcpv6-server-reconf
      exit
    dhcp-client-profile <client_profile>
      dhcpv6-client-unicast
      client-identifier { IMSI | MSISDN }
      enable rapid-commit-dhcpv6
      enable dhcp-message-spray
      request dhcp-option dns-address
      request dhcp-option netbios-server-address
      request dhcp-option sip-server-address
      end

```

Notes:

- **dhcp-server-profile** command creates a server profile and then enters the DHCP Server Profile configuration mode.
- **enable rapid-commit-dhcpv6** command enables rapid commit on the DHCPv6 server. By default it is disabled. This is done to ensure that if there are multiple DHCPv6 servers in a network, with rapid-commit-option, they would all end up reserving resources for the UE.
- **process dhcp-option-from** command configures in what order the configuration options should be processed for a given client request. For a given client configuration, values can be obtained from either AAA, PDN-DHCP-SERVER, or LOCAL. By default, AAA is preferred over PDN-DHCP, which is preferred over LOCAL configuration.
- **dhcpv6-server-preference:** According to RFC-3315, DHCPv6-CLIENT should wait for a specified amount of time before considering responses to its queries from DHCPv6-SERVERS. If a server responds with a preference value of 255, DHCPv6-CLIENT need not wait any longer. Default value is 0 and it may have any configured integer between 1 and 255.
- **enable dhcpv6-server-unicast** command enables server-unicast option for DHCPv6. By default, it is disabled.
- **enable dhcpv6-server-reconf** command configures support for reconfiguration messages from the server. By default, it is disabled.
- **dhcpv6-client-unicast** command Enables client to send messages on unicast address towards the server.

- **dhcp-client-profile** command creates a client profile and then enters the DHCP Client Profile configuration mode.
- **client identifier** command configures the client-identifier, which is sent to the external DHCP server. By default, IMSI is sent. Another available option is MSISDN.
- **enable rapid-commit-dhcpv6** command configures the rapid commit for the client. By default, rapid-commit option is enabled for both DHCPv4 & DHCPv6.
- **enable dhcp-message-spray** command enables dhcp-client to spray a DHCP message to all configured DHCP servers in the PDN. By default this is disabled. With Rapid-Commit, there can only be one server to which this can be sent.
- **request dhcp-option** command configures DHCP options which can be requested by the dhcp-client. It supports the following options:
 - dns-address
 - netbios-server-address
 - sip-server-address
 -
- Service names must be unique across all contexts within a chassis.

Associate DHCPv6 Configuration

Use the following example to associate the DHCPv6 profile with an APN:

```
configure
context <dest_ctxt_name>
  apn <apn_name>
    dhcpv6 service-name <dhcpv6_svc_name> server-profile <server_profile>
  client-profile <client_profile>
    dhcpv6 ip-address-pool-name <dhcpv6_ip_pool>
    dhcpv6 context-name <dest_ctxt>
  end
```

Notes:

- Service names must be unique across all contexts within a chassis.

DHCPv6 Service Configuration Verification

Step 1 Verify that your DHCPv6 servers configured properly by entering the following command in Exec Mode:

```
show dhcpv6-service all
```

This command produces an output similar to that displayed below where DHCPv6 service name is *dhcp6-service*:

```
Service name:          dhcpv6-service
Context:              A
Bind Address:         2092::192:90:92:40
Bind :               Done
Service Status:      Started
Server Dead Time:    120 (secs)
Server Dead consecutive Failure:5
```

```

Server Select Algorithm:      First Server
Server Renew Time:          400 (secs)
Server Rebind Time:         500 (secs)
Server Preferred Life Time:  600 (secs)
Server Valid Life Time:     700 (secs)
Max Retransmissions:        3 (secs)
Server Dead Tries:          4 (secs)
Server Resurrect Time:      10 (secs)
ipv6_nd_flag:               0_FLAG
DHCPv6 Servers configured:
    Address:                 2092::192:90:92:40 Priority: 1 enabled

```

Step 2 Verify the DHCPv6 service status by entering the following command in Exec Mode:

```
show dhcpv6 status service dhcpv6_service_name
```

Configuring Optional Features on the P-GW

The configuration examples in this section are optional and provided to cover the most common uses of the P-GW in a live network. The intent of these examples is to provide a base configuration for testing.

The following optional configurations are provided in this section:

- [Configuring ACL-based Node-to-Node IP Security on the S5 Interface, on page 212](#)
- [Configuring APN as Emergency, on page 215](#)
- [Configuring Dynamic Node-to-Node IP Security on the S5 Interface, on page 215](#)
- [Configuring the GTP Echo Timer, on page 218](#)
- [Configuring GTP Offline Accounting on the P-GW, on page 222](#)
- [Configuring Local QoS Policy, on page 224](#)
- [Configuring X.509 Certificate-based Peer Authentication, on page 226](#)
- [Configuring R12 Load Control Support, on page 227](#)
- [Configuring R12 Overload Control Support, on page 228](#)
- [Configuring Guard Timer on Create Session Request Processing, on page 228](#)
- [Configuring RLF Bypass, on page 229](#)

Configuring ACL-based Node-to-Node IP Security on the S5 Interface

The configuration example in this section creates an IKEv2/IPSec ACL-based node-to-node tunnel endpoint on the S5 interface.



Important Use of the IP Security feature requires that a valid license key be installed. Contact your local Sales or Support representative for information on how to obtain a license.

The following configuration examples are included in this section:

- [Creating and Configuring a Crypto Access Control List, on page 213](#)
- [Creating and Configuring an IPSec Transform Set, on page 213](#)

- [Creating and Configuring an IKEv2 Transform Set, on page 213](#)
- [Creating and Configuring a Crypto Map, on page 214](#)

Creating and Configuring a Crypto Access Control List

The following example configures a crypto ACL (Access Control List), which defines the matching criteria used for routing subscriber data packets over an IPsec tunnel:

```
configure
context <saegw_context_name> -noconfirm
  ip access-list <acl_name>
    permit tcp host <source_host_address> host <dest_host_address>
  end
```

Notes:

- The **permit** command in this example routes IPv4 traffic from the server with the specified source host IPv4 address to the server with the specified destination host IPv4 address.
- Service names must be unique across all contexts within a chassis.

Creating and Configuring an IPsec Transform Set

The following example configures an IPsec transform set, which is used to define the security association that determines the protocols used to protect the data on the interface:

```
configure
context <saegw_context_name> -noconfirm
  ipsec transform-set <ipsec_transform-set_name>
    encryption aes-cbc-128
    group none
    hmac sha1-96
    mode tunnel
  end
```

Notes:

- The encryption algorithm, **aes-cbc-128**, or Advanced Encryption Standard Cipher Block Chaining, is the default algorithm for IPsec transform sets configured on the system.
- The **group none** command specifies that no crypto strength is included and that Perfect Forward Secrecy is disabled. This is the default setting for IPsec transform sets configured on the system.
- The **hmac** command configures the Encapsulating Security Payload (ESP) integrity algorithm. The **sha1-96** keyword uses a 160-bit secret key to produce a 160-bit authenticator value. This is the default setting for IPsec transform sets configured on the system.
- The **mode tunnel** command specifies that the entire packet is to be encapsulated by the IPsec header including the IP header. This is the default setting for IPsec transform sets configured on the system.
- Service names must be unique across all contexts within a chassis.

Creating and Configuring an IKEv2 Transform Set

The following example configures an IKEv2 transform set:

```

configure
  context <saegw_context_name> -noconfirm
    ikev2-ikesa transform-set <ikev2_transform-set_name>
      encryption aes-cbc-128
      group 2
      hmac sha1-96
      lifetime <sec>
      prf sha1
    end

```

Notes:

- The encryption algorithm, **aes-cbc-128**, or Advanced Encryption Standard Cipher Block Chaining, is the default algorithm for IKEv2 transform sets configured on the system.
- The **group 2** command specifies the Diffie-Hellman algorithm as Group 2, indicating medium security. The Diffie-Hellman algorithm controls the strength of the crypto exponentials. This is the default setting for IKEv2 transform sets configured on the system.
- The **hmac** command configures the Encapsulating Security Payload (ESP) integrity algorithm. The **sha1-96** keyword uses a 160-bit secret key to produce a 160-bit authenticator value. This is the default setting for IKEv2 transform sets configured on the system.
- The **lifetime** command configures the time the security key is allowed to exist, in seconds.
- The **prf** command configures the IKE Pseudo-random Function which produces a string of bits that cannot be distinguished from a random bit string without knowledge of the secret key. The **sha1** keyword uses a 160-bit secret key to produce a 160-bit authenticator value. This is the default setting for IKEv2 transform sets configured on the system.
- Service names must be unique across all contexts within a chassis.

Creating and Configuring a Crypto Map

The following example configures an IKEv2 crypto map:

```

configure
  context <saegw_context_name>
    crypto map <crypto_map_name> ikev2-ipv4
      match address <acl_name>
      peer <ipv4_address>
      authentication local pre-shared-key key <text>
      authentication remote pre-shared-key key <text>
      ikev2-ikesa transform-set list <name1> . . . name6
      payload <name> match ipv4
      lifetime <seconds>
      ipsec transform-set list <name1> . . . <name4>
    exit
  exit
  interface <s5_intf_name>
    ip address <ipv4_address>
    crypto-map <crypto_map_name>
  exit
  port ethernet <slot_number/port_number>

```

```

no shutdown
bind interface <s5_intf_name> <saegw_context_name>
end

```

Notes:

- The type of crypto map used in this example is IKEv2/IPv4 for IPv4 addressing. An IKEv2/IPv6 crypto map can also be used for IPv6 addressing.
- The **ipsec transform-set list** command specifies up to four IPsec transform sets.
- Service names must be unique across all contexts within a chassis.

Configuring APN as Emergency

The configuration example in this section configures an emergency APN for VoLTE based E911 support.

In APN Configuration Mode, specify the name of the emergency APN and set the emergency inactivity timeout as follows. You may also configure the P-CSCF FQDN server name for the APN.

```

configure
context <saegw_context_name> -noconfirm
  apn <name>
    emergency-apn
    timeout emergency-inactivity <seconds>
    p-cscf fqdn <fqdn>
  end

```

Notes:

- By default, an APN is assumed to be non-emergency.
- The **timeout emergency-inactivity** command specifies the timeout duration, in seconds, to check inactivity on the emergency session. *<seconds>* must be an integer value from 1 through 3600.
- By default, emergency inactivity timeout is disabled (0).
- The **p-cscf fqdn** command configures the P-CSCF FQDN server name for the APN. *<fqdn>* must be a string from 1 to 256 characters in length.
- P-CSCF FQDN has more significance than CLI-configured P-CSCF IPv4 and IPv6 addresses.
- Service names must be unique across all contexts within a chassis.

Configuring Dynamic Node-to-Node IP Security on the S5 Interface

The configuration example in this section creates an IPsec/IKEv2 dynamic node-to-node tunnel endpoint on the S5 interface.



Important Use of the IP Security feature requires that a valid license key be installed. Contact your local Sales or Support representative for information on how to obtain a license.

The following configuration examples are included in this section:

- [Creating and Configuring an IPSec Transform Set, on page 216](#)
- [Creating and Configuring an IKEv2 Transform Set, on page 216](#)
- [Creating and Configuring a Crypto Template, on page 217](#)
- [Binding the S5 IP Address to the Crypto Template, on page 217](#)

Creating and Configuring an IPSec Transform Set

The following example configures an IPSec transform set, which is used to define the security association that determines the protocols used to protect the data on the interface:

```
configure
context <saegw_context_name> -noconfirm
  ipsec transform-set <ipsec_transform-set_name>
    encryption aes-cbc-128
    group none
    hmac sha1-96
    mode tunnel
  end
```

Notes:

- The encryption algorithm, **aes-cbc-128**, or Advanced Encryption Standard Cipher Block Chaining, is the default algorithm for IPSec transform sets configured on the system.
- The **group none** command specifies that no crypto strength is included and that Perfect Forward Secrecy is disabled. This is the default setting for IPSec transform sets configured on the system.
- The **hmac** command configures the Encapsulating Security Payload (ESP) integrity algorithm. The **sha1-96** keyword uses a 160-bit secret key to produce a 160-bit authenticator value. This is the default setting for IPSec transform sets configured on the system.
- The **mode tunnel** command specifies that the entire packet is to be encapsulated by the IPSec header, including the IP header. This is the default setting for IPSec transform sets configured on the system.
- Service names must be unique across all contexts within a chassis.

Creating and Configuring an IKEv2 Transform Set

The following example configures an IKEv2 transform set:

```
configure
context <saegw_context_name> -noconfirm
  ikev2-ikesa transform-set <ikev2_transform-set_name>
    encryption aes-cbc-128
    group 2
    hmac sha1-96
    lifetime <sec>
    prf sha1
  end
```

Notes:

- The encryption algorithm, **aes-cbc-128**, or Advanced Encryption Standard Cipher Block Chaining, is the default algorithm for IKEv2 transform sets configured on the system.

- The **group 2** command specifies the Diffie-Hellman algorithm as Group 2, indicating medium security. The Diffie-Hellman algorithm controls the strength of the crypto exponentials. This is the default setting for IKEv2 transform sets configured on the system.
- The **hmac** command configures the Encapsulating Security Payload (ESP) integrity algorithm. The **sha1-96** keyword uses a 160-bit secret key to produce a 160-bit authenticator value. This is the default setting for IKEv2 transform sets configured on the system.
- The **lifetime** command configures the time the security key is allowed to exist, in seconds.
- The **prf** command configures the IKE Pseudo-random Function, which produces a string of bits that cannot be distinguished from a random bit string without knowledge of the secret key. The **sha1** keyword uses a 160-bit secret key to produce a 160-bit authenticator value. This is the default setting for IKEv2 transform sets configured on the system.
- Service names must be unique across all contexts within a chassis.

Creating and Configuring a Crypto Template

The following example configures an IKEv2 crypto template:

```
configure
context <saegw_context_name> -noconfirm
  crypto template <crypto_template_name> ikev2-dynamic
    ikev2-ikesa transform-set list <name1> . . . <name6>
    ikev2-ikesa rekey
  payload <name> match childsa match ipv4
    ipsec transform-set list <name1> . . . <name4>
    rekey
  end
```

Notes:

- The **ikev2-ikesa transform-set list** command specifies up to six IKEv2 transform sets.
- The **ipsec transform-set list** command specifies up to four IPsec transform sets.
- Service names must be unique across all contexts within a chassis.

Binding the S5 IP Address to the Crypto Template

The following example configures the binding of the S5 interface to the crypto template.



Important If you modify the **interface-type** command, the parent service (service within which the eGTP/GTP-U service is configured) will automatically restart. Service restart results in dropping of active calls associated with the parent service.

```
configure
context <saegw_context_name> -noconfirm
  gtpu-service <gtpu_ingress_service_name>
    bind ipv4-address <s5_interface_ip_address> crypto-template
<sgw_s5_crypto_template>
  exit
  egtp-service <egtp_ingress_service_name>
```

```

interface-type interface-pgw-ingress
associate gtpu-service <gtpu_ingress_service_name>
gtpc bind ipv4-address <s5_interface_ip_address>
exit
pgw-service <pgw_service_name> -noconfirm
plmn id mcc <id> mnc <id> primary
associate egtp-service <egtp_ingress_service_name>
end

```

Notes:

- The **bind** command in the GTP-U and eGTP service configuration can also be specified as an IPv6 address using the **ipv6-address** command.
- Service names must be unique across all contexts within a chassis.

Configuring the GTP Echo Timer

The GTP echo timer on the ASR5x00 P-GW can be configured to support two different types of path management: default and dynamic. This timer can be configured on the GTP-C and/or the GTP-U channels.

Default GTP Echo Timer Configuration

The following examples describe the configuration of the default eGTP-C and GTP-U interface echo timers:

eGTP-C

```

configure
context <context_name>
  egtp-service <egtp_service_name>
    gtpc echo-interval <seconds>
    gtpc echo-retransmission-timeout <seconds>
    gtpc max-retransmissions <num>
  end

```

Notes:

- The following diagram describes a failure and recovery scenario using default settings of the three **gtpc** commands in the example above:

Figure 52: Failure and Recovery Scenario - Example 1

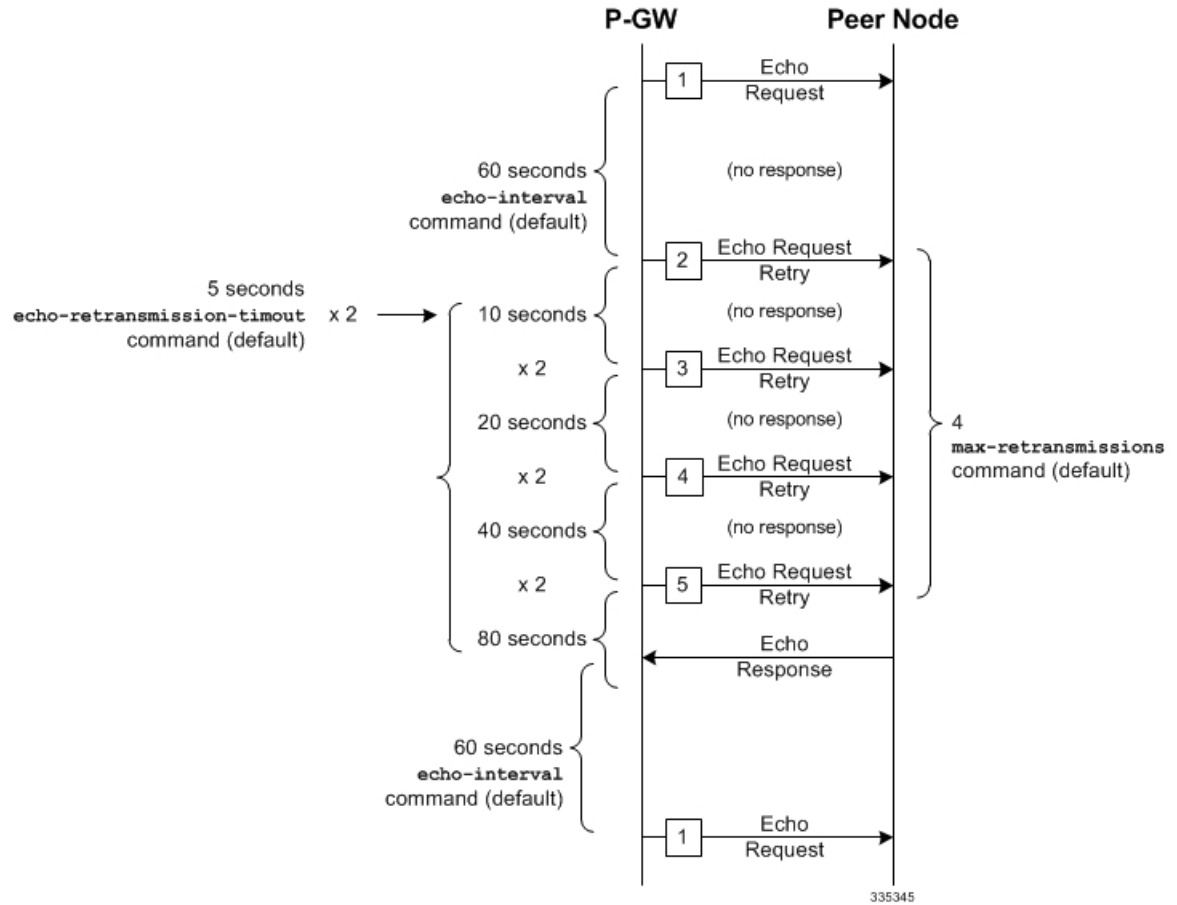

- The multiplier (x2) is system-coded and cannot be configured.
- Service names must be unique across all contexts within a chassis.

GTP-U

```

configure
context <context_name>
  gtpu-service <gtpu_service_name>
    echo-interval <seconds>
    echo-retransmission-timeout <seconds>
    max-retransmissions <num>
  end

```

Notes:

- The following diagram describes a failure and recovery scenario using default settings of the three GTP-U commands in the example above:

Figure 53: Failure and Recovery Scenario - Example 2

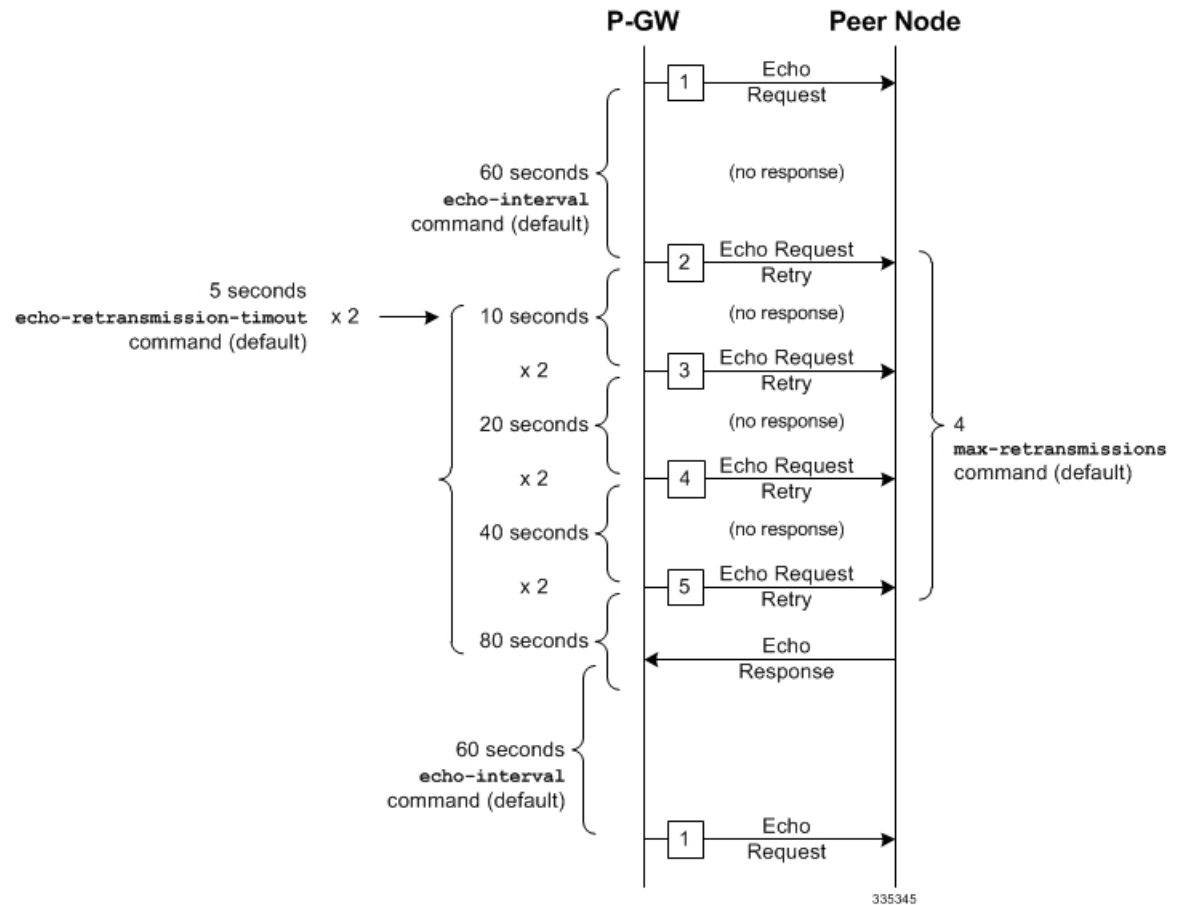

- The multiplier (x2) is system-coded and cannot be configured.
- Service names must be unique across all contexts within a chassis.

Dynamic GTP Echo Timer Configuration

The following examples describe the configuration of the dynamic eGTP-C and GTP-U interface echo timers:

eGTP-C

```
configure
  context <context_name>
    egtp-service <egtp_service_name>
      gtpc echo-interval <seconds> dynamic smooth-factor <multiplier>
      gtpc echo-retransmission-timeout <seconds>
      gtpc max-retransmissions <num>
    end
```

Notes:

- The following diagram describes a failure and recovery scenario using default settings of the three **gtpc** commands in the example above and an example round trip timer (RTT) of six seconds:

Figure 54: Failure and Recovery Scenario - Example 3

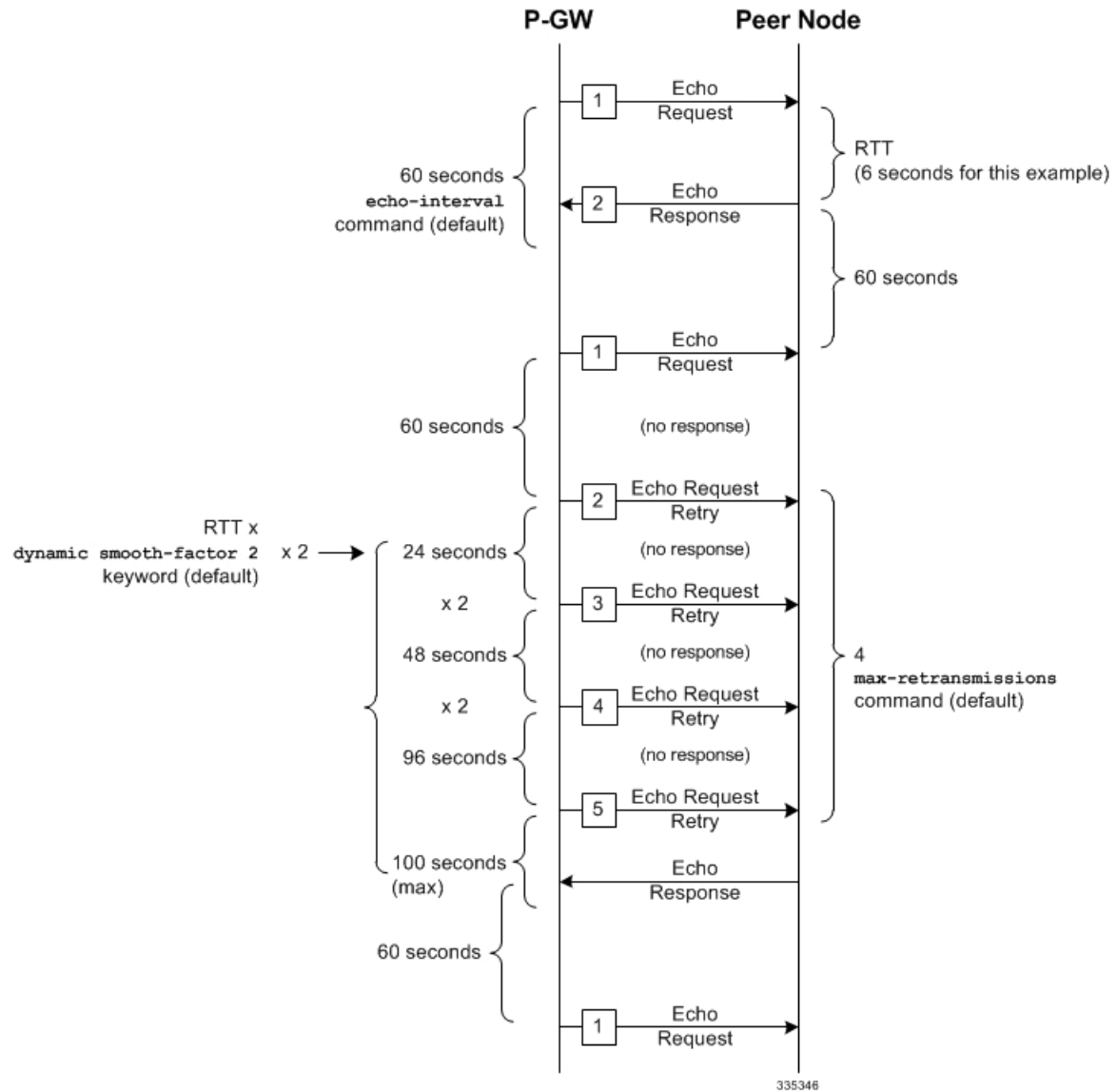

- The multiplier (x2) and the 100 second maximum are system-coded and cannot be configured.
- Service names must be unique across all contexts within a chassis.

GTP-U

```

configure
context <context_name>
  gtpu-service <gtpu_service_name>
  echo-interval <seconds> dynamic smooth-factor <multiplier>
  echo-retransmission-timeout <seconds>
  max-retransmissions <num>
end

```

Notes:

- The following diagram describes a failure and recovery scenario using default settings of the three **gtpc** commands in the example above and an example round trip timer (RTT) of six seconds:

Figure 55: Failure and Recovery Scenario - Example 4

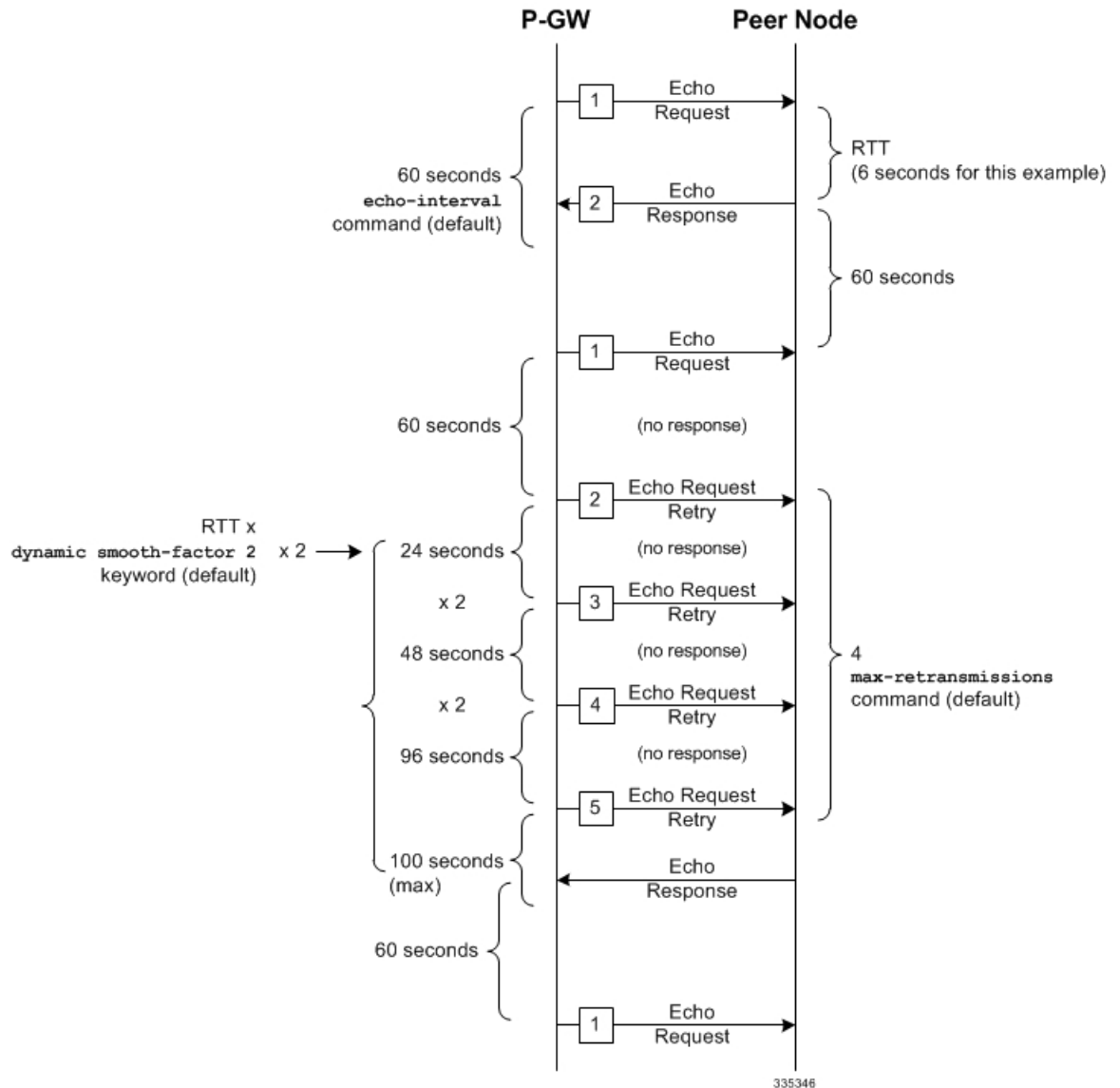

- The multiplier (x2) and the 100 second maximum are system-coded and cannot be configured.
- Service names must be unique across all contexts within a chassis.

Configuring GTPP Offline Accounting on the P-GW

By default the P-GW service supports GTPP accounting. To provide GTPP offline charging, configure the P-GW with the example parameters below:

```
configure
gtp single-source
```

```

context <saegw_context_name>
  subscriber default
    accounting mode gtp
    exit
  gtp group default
    gtp charging-agent address <gz_ipv4_address>
    gtp echo-interval <seconds>
    gtp attribute diagnostics
    gtp attribute local-record-sequence-number
    gtp attribute node-id-suffix <string>
    gtp dictionary <name>
    gtp server <ipv4_address> priority <num>
    gtp server <ipv4_address> priority <num> node-alive enable
    exit
  policy accounting <gz_policy_name>
    accounting-level {type}
    operator-string <string>
    cc profile <index> buckets <num>
    cc profile <index> interval <seconds>
    cc profile <index> volume total <octets>
    exit
  exit
context <saegw_context_name>
  apn apn_name
    associate accounting-policy <gz_policy_name>
    exit
  interface <gz_interface_name>
    ip address <address>
    exit
  exit
port ethernet <slot_number/port_number>
  no shutdown
  bind interface <gz_interface_name> <saegw_context_name>
end

```

Notes:

- **gtp single-source** is enabled to allow the system to generate requests to the accounting server using a single UDP port (by way of a AAA proxy function) rather than each AAA manager generating requests on unique UDP ports.
- **gtp** is the default option for the **accounting mode** command.
- An accounting mode configured for the call-control profile will override this setting.
- **accounting-level** types are: flow, PDN, PDN-QCI, QCI, and subscriber. Refer to the *Accounting Profile Configuration Mode Commands* chapter in the *Command Line Interface Reference* for more information on this command.
- Service names must be unique across all contexts within a chassis.

Configuring Local QoS Policy

The configuration examples in this section create a local QoS policy. A local QoS policy service can be used to control different aspects of a session, such as QoS, data usage, subscription profiles, or server usage, by means of locally defined policies.



Important Local QoS Policy is a licensed-controlled feature. Contact your Cisco account or support representative for detailed licensing information.

The following configuration examples are included in this section:

- [Creating and Configuring a Local QoS Policy, on page 224](#)
- [Binding a Local QoS Policy, on page 225](#)
- [Verifying Local QoS Policy, on page 226](#)

Creating and Configuring a Local QoS Policy

The following configuration example enables a local QoS policy on the P-GW:

```
configure
local-policy-service <name> -noconfirm
  ruledef <ruledef_name> -noconfirm
    condition priority <priority> <variable> match <string_value>
    condition priority <priority> <variable> match <int_value>
    condition priority <priority> <variable> nomatch <regex>
    exit
  actiondef <actiondef_name> -noconfirm
    action priority <priority> <action_name> <arguments>
    action priority <priority> <action_name> <arguments>
    exit
  actiondef <actiondef_name> -noconfirm
    action priority <priority> <action_name> <arguments>
    action priority <priority> <action_name> <arguments>
    exit
  eventbase <eventbase_name> -noconfirm
    rule priority <priority> event <list_of_events> ruledef <ruledef_name>
actiondef <actiondef_name>
end
```

Notes:

- A maximum of 16 local QoS policy services are supported.
- A maximum 256 ruledefs are suggested in a local QoS policy service for performance reasons.
- The **condition** command can be entered multiple times to configure multiple conditions for a ruledef. The conditions are examined in priority order until a match is found and the corresponding condition is applied.
- A maximum of 256 actiondefs are suggested in a local QoS policy service for performance reasons.
- The **action** command can be entered multiple times to configure multiple actions for an actiondef. The actions are examined in priority order until a match is found and the corresponding action is applied.

- Currently, only one eventbase is supported and must be named "default".
- The **rule** command can be entered multiple times to configure multiple rules for an eventbase.
- A maximum of 256 rules are suggested in an eventbase for performance reasons.
- Rules are executed in priority order, and if the rule is matched the action specified in the actiondef is executed. If an event qualifier is associated with a rule, the rule is matched only for that specific event. If a qualifier of **continue** is present at the end of the rule, the subsequent rules are also matched; otherwise, rule evaluation is terminated on first match.
- Service names must be unique across all contexts within a chassis.

Binding a Local QoS Policy

Option 1: The following configuration example binds the previously configured local QoS policy:

```
configure
context <saegw_context_name> -noconfirm
  apn <name>
    ims-auth-service <local-policy-service name>
  end
```

Notes:

- A maximum of 30 authorization services can be configured globally in the system. There is also a system limit for the maximum number of total configured services.
- Useful in case of emergency calls; PCRF is not involved.
- Service names must be unique across all contexts within a chassis.

Option 2: The following configuration example may also be used to bind the previously configured local QoS policy or a failure handling template:

```
configure
context <saegw_context_name> -noconfirm
  ims-auth-service <auth_svc_name>
    policy-control
      associate failure-handling-template <template_name>
      associate local-policy-service <service_name>
    end
```

Notes:

- Only one failure handling template can be associated with the IMS authorization service. The failure handling template should be configured prior to issuing this command.
- The failure handling template defines the action to be taken when the Diameter application encounters a failure supposing a result-code failure, tx-expiry or response-timeout. The application will take the action given by the template. For more information on failure handling template, refer to the *Diameter Failure Handling Template Configuration Mode Commands* chapter in the *Command Line Interface Reference*.
- You must select "local-fallback" in the failure handling template to support fallback to local policy.

- To support fallback to local policy in case of failure at PCRF, the local policy service should be associated with an IMS authorization service. In case of any failures, the local policy template associated with the ims-auth service will be chosen for fallback.
- Service names must be unique across all contexts within a chassis.

Verifying Local QoS Policy

The following configuration example verifies if local QoS service is enforced:

```
logging filter active facility local-policy level debug
logging active
show local-policy statistics all
```

Notes:

- Please take extreme caution not to use logging feature in console port and in production nodes.

Configuring X.509 Certificate-based Peer Authentication

The configuration example in this section enables X.509 certificate-based peer authentication, which can be used as the authentication method for IP Security on the P-GW.



Important Use of the IP Security feature requires that a valid license key be installed. Contact your local Sales or Support representative for information on how to obtain a license.

The following configuration example enables X.509 certificate-based peer authentication on the P-GW.

In Global Configuration Mode, specify the name of the X.509 certificate and CA certificate, as follows:

```
configure
certificate name <cert_name> pem url <cert_pem_url> private-key pem url
<private_key_url>
ca-certificate name <ca_cert_name> pem url <ca_cert_url>
end
```

Notes:

- The **certificate name** and **ca-certificate list ca-cert-name** commands specify the X.509 certificate and CA certificate to be used.
- The PEM-formatted data for the certificate and CA certificate can be specified, or the information can be read from a file via a specified URL as shown in this example.
- Service names must be unique across all contexts within a chassis.

When creating the crypto template for IPSec in Context Configuration Mode, bind the X.509 certificate and CA certificate to the crypto template and enable X.509 certificate-based peer authentication for the local and remote nodes, as follows:

```
configure
context <saegw_context_name> -noconfirm
crypto template <crypto_template_name> ikev2-dynamic
certificate name <cert_name>
```

```

ca-certificate list ca-cert-name <ca_cert_name>
authentication local certificate
authentication remote certificate
end

```

Notes:

- A maximum of 16 certificates and 16 CA certificates are supported per system. One certificate is supported per service, and a maximum of four CA certificates can be bound to one crypto template.
- The **certificate name** and **ca-certificate list ca-cert-name** commands bind the certificate and CA certificate to the crypto template.
- The **authentication local certificate** and **authentication remote certificate** commands enable X.509 certificate-based peer authentication for the local and remote nodes.
- Service names must be unique across all contexts within a chassis.

Configuring R12 Load Control Support

Load control enables a GTP-C entity (for example, an S-GW/P-GW) to send its load information to a GTP-C peer (e.g. an MME/SGSN, ePDG, TWAN) to adaptively balance the session load across entities supporting the same function (for example, an S-GW cluster) according to their effective load. The load information reflects the operating status of the resources of the GTP-C entity.

Use the following example to configure this feature:

```

configure
  gtpc-load-control-profile profile_name
    inclusion-frequency advertisement-interval interval_in_seconds
    weightage system-cpu-utilization percentage system-memory-utilization
percentage license-session-utilization percentage
  end
configure
  context context_name
    pgw-service pgw_service_name
      associate gtpc-load-control-profile profile_name
    exit
    saegw-service saegw_service_name
      associate pgw-service pgw_service_name
    end

```

Notes:

- The **inclusion-frequency** parameter determines how often the Load control information element is sent to the peer(s).
- The total of the three **weightage** parameters should not exceed 100.
- The **associate** command is used to associate the Load Control Profile with an existing S-GW service and to associate the P-GW service with the SAEGW service.
- On the SAEGW, both the P-GW and S-GW should use the same Load Control profile.

Configuring R12 Overload Control Support

Overload control enables a GTP-C entity becoming or being overloaded to gracefully reduce its incoming signaling load by instructing its GTP-C peers to reduce sending traffic according to its available signaling capacity to successfully process the traffic. A GTP-C entity is in overload when it operates over its signaling capacity, which results in diminished performance (including impacts to handling of incoming and outgoing traffic).

Use the following example to configure this feature.

```

configure
  gtpc-overload-control-profile profile_name
    inclusion-frequency advertisement-interval interval_in_seconds
    weightage system-cpu-utilization percentage system-memory-utilization
percentage license-session-utilization percentage
    throttling-behavior emergency-events exclude
    tolerance initial-reduction-metric percentage
    tolerance threshold report-reduction-metric percentage
self-protection-limit percentage
    validity-period seconds
  end
configure
  context context_name
    pgw-service pgw_service_name
      associate gtpc-overload-control-profile profile_name
    exit
    saegw-service saegw_service_name
      associate pgw-service pgw_service_name
    end

```

Notes:

- The **inclusion-frequency** parameter determines how often the Overload control information element is sent to the peer(s).
- The total of the three **weightage** parameters should not exceed 100.
- **validity-period** configures how long the overload control information is valid. Valid entries are from 1 to 3600 seconds. The default is 600 seconds.
- The **associate** command is used to associate the Overload Control Profile with an existing S-GW and P-GW service.
- On the SAEGW, both the P-GW and S-GW should use the same Overload Control profile.

Configuring Guard Timer on Create Session Request Processing

The P-GW has an existing timer "session setup-timeout" which is hard coded to 60 seconds, which is used as a guard timer for session creation. This timer is used for all APNs and is started when a Create Session Request is received for any session creation.

Internal or external processing issues or delay at external interfaces, for example, Gx/Gy, can cause Create Session Request processing to run longer than time expected in end to end call setup. If the session processing is not complete when the timer expires, the Create Session Request processing is stopped and the P-GW performs an internal cleanup by stopping all other corresponding sessions, for example Gx/Gy. The P-GW

responds with a Create Session Failure response stating that no resources are available to S-GW. In successful cases when there's no delay, the timer is stopped while sending out the Create Session Response.

A new CLI command has been introduced to allow a configurable value to override the previously hardcoded default session setup timeout value of 60 seconds. This will help to fine tune the call setup time at P-GW with respect to end to end call setup time.

Configuring Session Timeout

The following configuration example makes a P-GW session setup timeout configurable.

```
configure
  context context_name
    pgw-service service_name
      setup-timeout timer-value
      [ default | no ] setup-timeout
    end
```

Notes:

- **setup-timeout:** Specifies the session setup timeout period, in seconds. If P-GW is able to process the Create Session Request message before the timer expires, P-GW stops the timer and sends a successful Create Session Response.

timer_value must be an integer from 1 to 120.

Default: 60 seconds

- **default:** Default value is 60 seconds. If no value is set, the P-GW service sets the timer to the default value.
- **no:** Sets the timer to the default value of 60 seconds.

Configuring RLF Bypass

The Bypass Rate Limit Function is an enhancement to the existing GTP Throttling feature. The RLF feature allows the operator to control the bypassing of some messages being throttled.

A new command option **throttling-override-policy** has been added to the existing CLI command **gtpc overload-protection egress rlf-template rlf-temp** which allows you to selectively by-pass throttling for a configured message type or for all messages in emergency call or priority call or call for the configured APN. A new CLI command mode **throttling-override-policy** has been also been introduced for Generic syntax for throttling override policy.

Configuring the Throttling Override Policy Mode

The following configuration helps to create a GTP-C Throttling Override Policy and to enter GTP-C Throttling Override Policy mode.

```
configure
  throttling-override-policy throttling-override-policy_name
```

Notes:

Entering the above command sequence results in the following prompt:

```
[local] host_name (config-throttling-override-policy)
```

Configuring RLF Bypass Feature

The following configuration configures message types which can bypass the rate limiting function.

```
configure
  throttling-override-policy throttling-override-policy_name
    [ default | no ] egress bypass-rlf pgw { msg-type { cbr | dbr | ubr
  | emergency-call | earp-pl-list {1 | 2 | 3 | 4 | 5 ... | 15 }+ |
apn-names <apn-name1> <apn-name2> <apn-name3> }
  end
```

Notes:

- If an empty throttling-override-policy is created, then the default values for all the configurables are zeros/disabled.
- If no throttling-override-policy is associated, then **show service configuration** for P-GW will show it as "n/a".
- Maximum number of throttling-override-policy that can be added are 1024. This limit is the same as max RLF templates.

Example

The following command configures Create Bearer Request message type at the P-GW node to bypass throttling.

```
egress bypass-rlf pgw msg-type cbr
```



CHAPTER 3

Monitoring the Service

This chapter provides information for monitoring service status and performance using the **show** commands found in the Command Line Interface (CLI). These command have many related keywords that allow them to provide useful information on all aspects of the system ranging from current software configuration through call activity and status.

The selection of keywords described in this chapter is intended to provided the most useful and in-depth information for monitoring the system. For additional information on these and other **show** command keywords, refer to the *Command Line Interface Reference*.

In addition to the CLI, the system supports the sending of Simple Network Management Protocol (SNMP) traps that indicate status and alarm conditions. Refer to the *SNMP MIB Reference* for a detailed listing of these traps.

- [Monitoring System Status and Performance, on page 231](#)
- [Clearing Statistics and Counters, on page 237](#)

Monitoring System Status and Performance

This section contains commands used to monitor the status of tasks, managers, applications and other software components in the system. Output descriptions for most of the commands are located in the *Statistics and Counters Reference*.

Table 28: System Status and Performance Monitoring Commands

To do this:	Enter this command:
View Congestion-Control Information	
View Congestion-Control Statistics	show congestion-control statistics {a11mgr ipsecmgr}
View GTP Information	
View eGTP-C service statistics for a specific service	show egtpc statistics egtpc-service name
View eGTP-C service information for a specific service	show egtpc-service name
View GTP-U service statistics for all GTP-U data traffic on the system	show gtpu statistics

To do this:	Enter this command:
View eGTP-U service information for a specific service	show gtpu-service <i>name</i>
View Infrastructure-DNS Queries	
Verify Infrastructure-DNS queries to resolve P-CSCF FQDN	dns-client query <i>client-name</i> <i>client_name</i> query-type AAAA query-name <i><p-cscf.com></i>
View IP Information	
Display BGP Neighbors	
Verify BGP neighbors on egress P-GW context	context <i>egress_pgw_context_name</i> show ip bgp summary
Verify BGP neighbors on ingress P-GW context	context <i>ingress_pgw_context_name</i> show ip bgp summary
Display IP Connectivity State	
Verify IP connectivity to the diameter servers for various components/interfaces; all peers should be in OPEN or WAIT_DWR state	show diameter peers full all grep State
Display IP Interface Status	
Verify IP interfaces are up on each context	show ip interface summary show ipv6 interface summary
Display IP Pool Configuration	
Verify IPv4 pools have been created and are available	context <i>egress_pgw_context_name</i> show ip pool summary
Verify IPv6 pools have been created and are available	context <i>egress_pgw_context_name</i> show ipv6 pool summary
View SAEGW Service Information	
View SAEGW service statistics	show saegw-service statistics all
Verify SAEGW services	context <i>saegw_context_name</i> show saegw-service all grep Status
View S-GW Service Information	
View S-GW service statistics	show sgw-service statistics all
Verify S-GW services	show sgw-service all grep Status show mag-service all grep Status
View P-GW Service Information	

To do this:	Enter this command:
View P-GW service statistics	show pgw-service statistics all
Verify P-GW services	show pgw-service all grep Status show lma-service all grep Status show egtp-service all grep Status show gtpu-service all grep State
View LMA Service Information	
View LMA service statistics for a specific service	show lma-service statistics lma-service <i>service_name</i>
View QoS/QCI Information	
View QoS Class Index to QoS mapping tables	show qci-qos-mapping table all
View RF Accounting Information	
Confirm the PGW is sending Rf accounting records: <ul style="list-style-type: none"> • Verify "Message sent" is non-zero • Verify active charging sessions are present 	show diameter accounting servers grep Message show active-charging sessions all more
View Session Subsystem and Task Information	
Display Session Subsystem and Task Statistics	
Important Refer to the <i>System Software Task and Subsystem Descriptions</i> appendix in the <i>System Administration Guide</i> for additional information on the Session subsystem and its various manager tasks.	
View AAA Manager statistics	show session subsystem facility aaamgr all
View AAA Proxy statistics	show session subsystem facility aaaproxy all
View LMA Manager statistics	show session subsystem facility hamgr all
View MAG Manager statistics	show session subsystem facility magmgr all
View Session Manager statistics	show session subsystem facility sessmgr all
View Session Disconnect Reasons	
View session disconnect reasons with verbose output	show session disconnect-reasons
View Session Recovery Information	
View session recovery status	show session recovery status [verbose]
View Subscriber Information	
Display NAT Information	

To do this:	Enter this command:
View the private IP assigned to the NAT user, along with any other public IPs assigned	show subscriber full username <i>user_name</i>
View NAT realms assigned to this user	show subscriber full username <i>user_name</i> grep -i nat
View active charging flows for a specific NAT IP address	show active-charging flows full nat required nat-ip <i>ip_address</i>
Display Session Resource Status	
View session resource status	show resources session
View Statistics for Subscribers using SAEGW Services on the System	
View statistics for subscribers using any SAEGW service on the system	show subscribers saegw-only full
View statistics for subscribers using a specific SAEGW service on the system	show subscribers saegw-service <i>service_name</i>
View Statistics for Subscribers using S-GW Services on the System	
View statistics for subscribers using any S-GW service on the system	show subscribers sgw-only full
View statistics for subscribers using a specific S-GW service on the system	show subscribers sgw-service <i>service_name</i>
View Statistics for Subscribers using P-GW Services on the System	
View statistics for subscribers using any P-GW service on the system	show subscribers pgw-only full
View statistics for subscribers using a specific P-GW interface	show subscribers pgw-address <i>ip_address</i>
View Statistics for Subscribers using MAG Services on the System	
View statistics for subscribers using any MAG service on the system	show subscribers mag-only full
View statistics for subscribers using a specific MAG service on the system	show subscribers mag-service <i>service_name</i>
View Statistics for Subscribers using LMA Services on the System	
View statistics for subscribers using a specific LMA service on the system	show subscribers lma-service <i>service_name</i>
Display Subscriber Configuration Information	
View locally configured subscriber profile settings (must be in context where subscriber resides)	show subscribers configuration username <i>subscriber_name</i>
View remotely configured subscriber profile settings	show subscribers aaa-configuration username <i>subscriber_name</i>

To do this:	Enter this command:
View Subscribers Currently Accessing the System	
View a listing of subscribers currently accessing the system	show subscribers all
Display UE Attach Status	
Confirm that a UE has attached: <ul style="list-style-type: none"> • Displays IMSI with one entry for each bearer per APN connection • Verify active charging sessions are present • Verify peers are active. Peers should correspond to S-GW EGTP addresses • Verify "Create Session Request" and "Create Session Response" categories are incrementing • Verify "Total Data Stats:" are incrementing eHRPD: <ul style="list-style-type: none"> • Verify lma-sessions are present • Verify "Binding Updates Received:" categories are incrementing 	show subscriber pgw-only imsi ue_imsi show active-charging sessions all more show egtpc peers show egtpc statistics show gtpu statistics eHRPD only show lma-service session username user_name show lma-service statistics

Configuring the SAEGW to Include the IMSI/IMEI in System Event Logs of Type Error and Critical

The SAEGW can be configured to provide the IMSI/IMEI in the event log details for the following system event logs of type error and critical, if available. If the IMSI is not available, the SAEGW will make a best effort to obtain the IMEI.

Table 29: New and Modified System Event Logs with IMSI/IMEI in System Event Log Details

Event Log	Description
New Events	
12225	Represents misc_error3 in format "[IMSI <IMSI>] Misc Error3: s, error code d"
12226	Represents recover_call_from_crr_failed1 error in format "[IMSI <IMSI>]Sessmgr-d Recover call from CRR failed for callid:0xx reason=s"
12227	Represents aaa_create_session_failed_no_more_sessions1 error in format "[IMSI <IMSI>] Sessmgr-d Ran out of session handles"
140075	Represents error_log1 in format "[IMSI <IMSI>]s"
Modified Events	

Event Log	Description
139001	To print miscellaneous PGW error log.
191006	To print miscellaneous SAEGW error log.
10034	Represents FSM error in format "[IMSI <IMSI>] default call fsm error: ostate=s(d) state=s(d) event=s(d)"
10035	Represents FSM INVALID event in format "[IMSI <IMSI>] default call fsm invalid event: state=s(d) event=s(d)"
12382	Represents SN_LE_SESSMGR_PGW_REJECT_BEARER_OP in format "[IMSI <IMSI>] Sessmgr-d: Request to s bearer rejected. Reason: s". For example "[IMSI 112233445566778 Sessmgr-1: Request to Create bearer rejected. Reason: Create Bearer Request denied as session recovery is in progress"
12668	Represents fsm_event_error in format "[IMSI <IMSI>] Misc Error: Bad event in sessmgr fsm, event code d"
12774	Represents pgw_purge_invalid_err in format "[IMSI <IMSI>] Local s TEID [lu] Collision: Clp Connect Time: lu, Old Clp Callid: d, Old Clp Connect Time: lu s"
12855	Represents ncqos_nrspca_trig_err in format "[IMSI <IMSI>] NCQOS NRSPCA trig rcvd in invalid bcm mode."
12857	Represents ncqos_nrupc_tft_err in format "[IMSI <IMSI>] NCQOS NRUPC Trig : TFT validation failed for nsapi <u>."
12858	Represents ncqos_nrxx_trig_already in format "[IMSI <IMSI>] NCQOS NRSPCA/NRUPC is already triggered on sess with nsapi <u>."
12859	Represents ncqos_nrxx_tft_check_fail in format "[IMSI <IMSI>] NCQOS TFT check failed as TFT has invalid opcode for nsapi <u>:pf_id_bitmap 0xx and tft_opcode: d"
12860	Represents ncqos_sec_rej in format "[IMSI <IMSI>] NCQOS Secondary ctxt with nsapi <u> rejected, due to <s>."
12861	Represents ncqos_upc_rej in format "[IMSI <IMSI>] UPC Rejected for ctxt with nsapi <u>, due to <s>."
12862	Represents ggsn_subsession_invalid_state in format "[IMSI <IMSI>] GGSN subsession invalid state state:<s>,[event:<s>]"
11830	Represents gngp_handoff_rejected_for_pdn_ipv4v6 in format "[IMSI <IMSI>] Sessmgr-d Handoff from PGW-to-GGSN rejected, as GGSN doesnt support Deffered allocation for IPv4v6, dropping the call."
11832	Represents gngp_handoff_rejected_no_non_gbr_bearer_for_def_bearer_selection in format "[IMSI <IMSI>] Sessmgr-d Handoff from PGW-to-GGSN rejected, as GGSN Callline has no non-GBR bearer to be selected as Default bearer."
11834	Represents gngp_handoff_from_ggsn_rejected_no_ggsn_call in format "[IMSI <IMSI>] Sessmgr-d Handoff from GGSN-to-PGW rejected, as GGSN call with TEIDC <0xx> not found."

Event Log	Description
12960	Represents gtp_pdp_type_mismatch in format "[IMSI <IMSI>] Mismatch between PDP type of APN s and in create req. Rejecting call"
11282	Represents pcc_intf_error_info in format "[IMSI <IMSI>] s"
11293	Represents collision_error in format "[IMSI <IMSI>] Collision Error: Temp Failure Handling Delayed Pending Active Transaction: , error code d"
11917	Represents rcvd_invalid_bearer_binding_req_from_acs in format "[IMSI <IMSI>] Sessmgr d: Received invalid bearer binding request from ACS."
11978	Represents saegw_uid_error in format "[IMSI <IMSI>] s"
11994	Represents unwanted_pcc_intf_setup_req error in format "[IMSI <IMSI>] GGSN_INITIATE_SESS_SETUP_REQ is already fwded to PCC interface "
140005	Represents ue_fsm_illegal_event in format "[IMSI <IMSI>] Invalid/unhandled UE event <s> in state <s>"
140006	Represents pdn_fsm_illegal_event in format "[IMSI <IMSI>] Invalid/unhandled PDN event <s> in state <s>"
140007	Represents epsb_fsm_illegal_event in format "[IMSI <IMSI>] Invalid/unhandled EPSB event <s> in state <s>"
10726	Represents saegwdrv_generic_error "[IMSI <IMSI>] s"

Configuring the SAEGW to Include the IMSI/IMEI in System Event Logs of Type Error and Critical

The **include-ueid** keyword has been added to the **logging** command in Global Configuration Mode. When enabled, the previously mentioned system events of type error and critical will provide the IMSI/IMEI in the logging details, if available.

```
configure
  logging include-ueid
  no logging include-ueid
end
```

Notes:

- **no** disables the inclusion of the IMSI/IMEI in system event logs of type error and critical.
- Use the **show configuration** command to view the current configuration status of the **logging include-ueid** command.
 - logging include-ueid (when enabled)
 - no logging include-ueid (when disabled).

Clearing Statistics and Counters

It may be necessary to periodically clear statistics and counters in order to gather new information. The system provides the ability to clear statistics and counters based on their grouping (PPP, MIPHA, MIPFA, etc.).

Statistics and counters can be cleared using the CLI **clear** command. Refer to the *Command Line Reference* for detailed information on using this command.



CHAPTER 4

3GPP Changes to the Gx Interface

- [Feature Information](#), on page 239
- [Feature Changes](#), on page 240
- [Limitations](#), on page 240

Feature Information

Summary Data

Status	Modified Functionality
Introduced-In Release	21.1
Modified-In Release(s)	21.2
Applicable Product(s)	P-GW, SAEGW
Applicable Platform(s)	ASR 5500
Default Setting	Yes, only for Customer specific Gx Dictionary.
Related CDETS ID(s)	CSCvc99275
Related Changes in This Release	Not Applicable
Related Documentation	P-GW Administration Guide SAEGW Administration Guide

Revision History



Important Revision history details are not provided for features introduced before release 21.2.

Revision Details	Release	Release Date
Modified in this release.	21.2	April 27, 2017

Feature Changes

Currently, P-GW sends 3GPP-User-Location-Info AVP in CCR-U for the event trigger Successful_Resource_Allocation, only if there is a change in the ULI. This feature has been implemented to comply with the 3GPP specifications. With this feature, P-GW sends 3GPP-User-Location-Info in CCR-U for the event trigger Successful_Resource_Allocation, even if there is no a change in the ULI. If the Resource-Allocation-Notification AVP is included in the Charging-Rule-Install AVP, 3GPP-User-Location-Information is included in the CCR-U sent towards the PCRF.

Limitations

Following are the limitations of this feature:

1. This feature works with diameter dictionary dpca-custom8.
2. Resource-Allocation-Notification AVP should be included within a Charging-Rule-Install AVP while installing/modifying rule.



CHAPTER 5

5G NSA for SAEGW

- [Feature Summary and Revision History, on page 241](#)
- [Feature Description, on page 243](#)
- [How It Works, on page 247](#)
- [Configuring 5G NSA for SAEGW, on page 252](#)
- [Monitoring and Troubleshooting, on page 256](#)

Feature Summary and Revision History

Summary Data

Applicable Product(s) or Functional Area	<ul style="list-style-type: none">• P-GW• S-GW• SAEGW
Applicable Platform(s)	<ul style="list-style-type: none">• ASR 5000• ASR 5500• VPC-DI• VPC-SI
Feature Default	Disabled - Configuration Required
Related Changes in This Release	Not applicable

Related Documentation	<ul style="list-style-type: none"> • <i>5G Non Standalone Solution Guide</i> • <i>AAA Interface Administration and Reference</i> • <i>Command Line Interface Reference</i> • <i>P-GW Administration Guide</i> • <i>S-GW Administration Guide</i> • <i>SAEGW Administration Guide</i> • <i>Statistics and Counters Reference</i>
-----------------------	--

Revision History

The 5G NSA solution for SAEGW supports deca-custom26 dictionary.	21.26
The 5G NSA solution for SAEGW supports Secondary RAT Usage IE during GnGp handover.	21.22
The 5G NSA solution for SAEGW supports deca-custom1, deca-custom7 and deca-custom8 dictionaries.	21.11
<p>The 5G NSA solution for SAEGW supports the following functionality:</p> <ul style="list-style-type: none"> • P-GW Custom Dictionaries support over Gz for extended bitrate • S-GW Custom Dictionaries support over Gz for extended bitrate • P-GW Custom Dictionaries support over Gy and Rf for extended bitrate • S-GW support of Secondary RAT Data Usage Report in Gz CDRs 	21.10
<p>The 5G NSA solution for SAEGW supports the following functionality:</p> <ul style="list-style-type: none"> • P-GW support of Secondary RAT Data Usage Report in Gz CDRs • P-GW support of Secondary RAT Data Usage Report in Rf CDRs • S-GW and P-GW support of statistics for DCNR PDNs 	21.9
The 5G NSA solution is qualified on the ASR 5000 platform.	21.5
<p>The 5G NSA solution for SAEGW supports the following functionality:</p> <ul style="list-style-type: none"> • Feature License • Dedicated Bearers • Gy interface • URLLC QCI 	21.8
First introduced.	21.6

Feature Description



Important 5G NSA feature is license controlled from release 21.8 onwards. Contact your Cisco account representative for detailed information on specific licensing requirements.

The 5G NSA solution for SAEGW supports the following functionalities:

- **High Throughput**

5G NR offers downlink data throughput up to 20 Gbps and uplink data throughput up to 10 Gbps. Some interfaces in EPC have the support to handle (encode/decode) 5G throughput. For example, NAS supports up to 65.2 Gbps (APN-AMBR) and S5/S8/S10/S3 (GTP-v2 interfaces) support up to 4.2 Tbps. The diameter interfaces S6a and Gx support only up to 4.2Gbps throughput, S1-AP supports only up to 10 Gbps and NAS supports up to 10 Gbps (MBR, GBR). New AVP/IE have been introduced in S6a, Gx, S1-AP, and NAS interfaces to support 5G throughput. See the *How It Works* section for more information.

- **DCNR Support on P-GW:**

Supports configuration of DCNR feature at the P-GW-service, by configuring “Extended-BW-NR” feature in IMSA service. Advertises the DCNR feature support by sending “Extended-BW-NR” feature bit in “Feature-List-ID-2” towards PCRF. Forwards AVP "Extended-APN-AMBR-UL" and "Extended-APN-AMBR-DL" in CCR messages when it receives APN-AMBR values greater than 4.2Gbps from MME/S-GW. Decodes the extended AVP "Extended-APN-AMBR-UL" and "Extended-APN-AMBR-DL" when it is received from PCRF.

- Sends AVP "Extended-Max-Requested-BW-UL", "Extended-Max-Requested-BW-DL", "Extended-GBR-UL" and "Extended-GBR-DL" when it receives MBR and GBR values greater than 4.2Gbps from MME/S-GW. Decodes the AVP "Extended-Max-Requested-BW-UL", "Extended-Max-Requested-BW-DL", "Extended-GBR-UL" and "Extended-GBR-DL" when received from PCRF. Supports dedicated bearer establishment with extended QoS. Sends AVP Extended-Max-Requested-BW-UL and "Extended-Max-Requested-BW-DL" in Gy records.

- **Ultra Low Latency Support:**

Supports 5G requirements of Ultra-Reliable and Low Latency Communications (URLLC). 3GPP introduced URLCC QCI 80 (Non-GBR resource type), QCI 82 and 83 (GBR resource type). P-GW establishes default bearers with URLLC QCI 80, which is typically used by low latency eMBB applications. P-GW establishes dedicated bearers with URLLC QCI 82 and 83 (also with QCI 80 if dedicated bearers of Non-GBR type to be established), which is typically used by discrete automation services (industrial automation).

- **ICSR Support**

With release 21.10 onwards ICSR for 5G NSA on SAEGW is supported.

- **Dynamic S-GW and P-GW selection by MME for DCNR capable UE**

When DCNR capable UE attempts to register in MME and when all DCNR validations are successful (for example DCNR feature configuration on MME, HSS not sending access-restriction for NR, and so on), the MME sets “UP Function Selection Indication Flags” IE with DCNR flag set to 1 in “Create Session Request” message. This feature is relevant for CUPS architecture to help SGW-C and PGW-C

to select SGW-U and PGW-U which supports dual connectivity with NR. When S-GW receives this IE over S11, it sends this IE over S5 to P-GW. S-GW ignores IE if it receives it in Non-CUPS deployment.

• P-GW Secondary RAT Usage Data Report Handling:

P-GW supports custom24 and custom44 for Gz and aaa-custom3, aaa-custom4 and aaa-custom6 dictionaries for Rf to support Secondary RAT Data Usage Report in CDRs.

Support for Secondary RAT Usage During GnGp Handover

This feature supports the Secondary RAT usage reported in change notification request during 4G to 3G handover. The support is for handling the change notification with Secondary RAT Usage during the GnGp handover. Step 13 is added in the following diagram in support of this feature. The usage must be reported in next CDR generation.

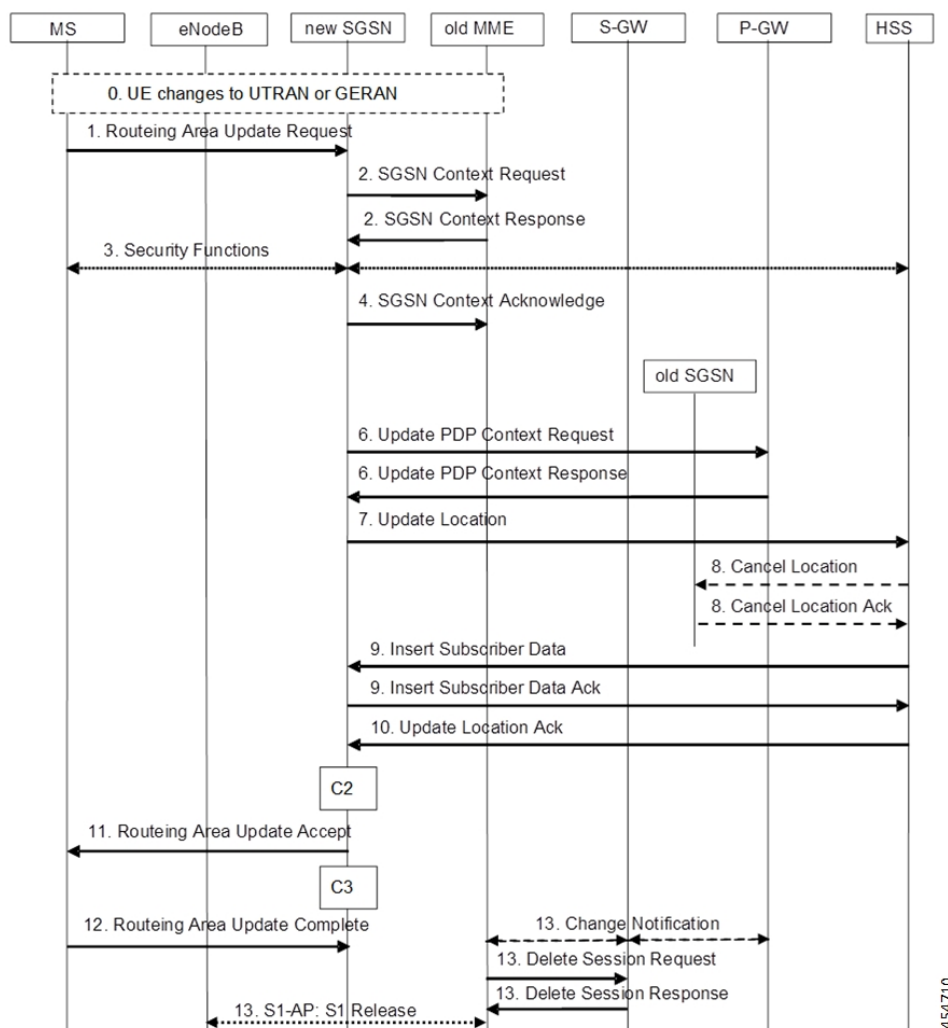

IMSI Not Known

If there's no context found for IMSI specified in Secondary RAT Usage IE of change notification request Message, it returns the change notification response with cause value "IMSI/IMEI not known".

Limitations

Following are the known limitations for this feature:

- This feature only supports the handling of the secondary RAT usage IE.
- During the 4G to 3G handover, dedicated bearers are retained and Secondary RAT usage is reported for both Default and Dedicated bearers.

Enabling Secondary RAT Data Usage Report

Use the following configuration to enable Secondary RAT Data Usage Report:

```
configure
context context_name
  pgw-service service_name
  dcnr
end
```



Note The GGSN service associated with the P-GW service must have the DCNR enabled using the preceding CLI.

- **Statistics support for DCNR PDNs:**

S-GW and P-GW statistics support for DCNR PDNs

- **S-GW Secondary RAT Usage Data Report Handling:**

S-GW supports custom24 and custom6 dictionaries to support Secondary RAT Data Usage Report in CDRs over Gz.

- **P-GW Custom Dictionaries Support over Gz:**

P-GW supports Custom44 and Custom24 dictionaries to support sending the following AVPs when it receives MBR, GBR and APN-AMBR values greater than 4.2Gbps:

- Extended-Max-Requested-BW-UL
- Extended-Max-Requested-BW-DL
- Extended-GBR-UL
- Extended-GBR-DL
- Extended-APN-AMBR-UL
- Extended-APN-AMBR-DL

- **Multiple Presence Reporting Area Support:**

S-GW supports Multiple-PRA action and Multiple-PRA Information over S11/S4 and S5/S8 interfaces.
P-GW supports Multiple-PRA Action and Multiple-PRA Information over S5/S8 and Gx interfaces.

- **S-GW Custom Dictionaries Support over Gz :**

S-GW supports custom24 and custom6 dictionaries to support sending the following AVPs when it receives MBR, GBR and APN-AMBR values greater than 4.2Gbps:

- Extended-Max-Requested-BW-UL
- Extended-Max-Requested-BW-DL
- Extended-GBR-UL
- Extended-GBR-DL
- Extended-APN-AMBR-UL
- Extended-APN-AMBR-DL

• **P-GW Custom Dictionaries Support over Gx:**

P-GW supports dpca-custom15, dpca-custom11, dpca-custom23, dpca-custom19 and dpca-custom17, dictionaries to support sending the following AVPs when it receives GBR and APN-AMBR values greater than 4.2Gbps:

- Extended-Max-Requested-BW-UL
- Extended-Max-Requested-BW-DL
- Extended-GBR-DL
- Extended-GBR-UL
- Extended-APN-AMBR-UL
- Extended-APN-AMBR-DL

• **P-GW Custom Dictionaries Support over Gy:**

P-GW supports dcca-custom1, dcca-custom7, dcca-custom8, dcca-custom13 and dcca-custom26 dictionaries to support sending the following AVPs when it receives GBR and APN-AMBR values greater than 4.2Gbps:

- Extended-Max-Requested-BW-UL
- Extended-Max-Requested-BW-DL
- Extended-GBR-DL
- Extended-GBR-UL
- Extended-APN-AMBR-UL
- Extended-APN-AMBR-DL

• **P-GW Custom Dictionaries Support over Rf:**

P-GW supports aaa-custom3, aaa-custom4 and aaa-custom6 dictionaries to support sending the following AVPs when it receives GBR and APN-AMBR values greater than 4.2Gbps:

- Extended-Max-Requested-BW-UL
- Extended-Max-Requested-BW-DL
- Extended-GBR-UL
- Extended-GBR-DL

- Extended-APN-AMBR-UL
- Extended-APN-AMBR-DL

Multiple Presence Reporting Area

P-GW supports negotiation of Multiple-Presence Reporting Area feature in Feature-List-ID 2 over Gx interface with PCRF. The CNO-ULI feature will be used only when the P-GW and/or the PCRF does not support Multiple-PRA and both P-GW and PCRF support CNO-ULI.



Note This feature is introduced in release 21.9.1. For more information, refer to the *Presence Reporting Area* chapter in the *P-GW Administration Guide*.

How It Works

Architecture

This section describes the architecture for Gx (PCRF), Gy (OCS), Gz (P-GW), and Rf (P-GW) interfaces with respect to 5G NSA for SEAEGW feature.

Gx (PCRF)

The Gx interface supports new AVPs to handle 5G throughput for default bearers and dedicated bearers. Gx interface introduced new "AVP Extended-APN-AMBR-UL" and "Extended-APN-AMBR-DL" in grouped "AVP QoS-Information" and "Conditional-APN-Aggregate-Max-Bitrate" to handle 5G throughput for default bearers. New AVPs "Extended-GBR-UL", "Extended-GBR-DL", "Extended-Max-Requested-BW-UL" and "Extended-Max-Requested-BW-DL" are added in grouped AVP "QoS-Information" for dedicated bearers.

When the maximum bandwidth value set for UL or DL traffic is higher than 4294967295 bits per second, the "Max-Requested-Bandwidth-UL" or DL, AVP must be present, and set to its upper limit 4294967295 along with the "Extended-Max-Requested-BW-UL" or DL must be present, and set to the requested bandwidth value in kilobits per second. The same principal applies for "Extended-GBR-UL/DL" and "Extended-APN-AMBR-UL/DL".

The following new AVPs are introduced in the grouped AVP QoS-Information:

- Extended-Max-Requested-BW-UL
- Extended-Max-Requested-BW-DL
- Extended-GBR-UL
- Extended-GBR-DL
- Extended-APN-AMBR-UL
- Extended-APN-AMBR-DL

the following new AVPs are introduced in the grouped AVP Conditional-APN-Aggregate-Max-Bitrate.

- Extended-APN-AMBR-UL
- Extended-APN-AMBR-DL

Gy (OCS)

New AVPs "Extended-Max-Request-BW-UL", "Extended-Max-Requested-BW-DL", "Extended-GBR-UL", "Extended-GBR-DL", "Extended-APN-AMBR-UL" and "Extended-APN-AMBR-DL" in grouped AVP "QoS-Information" are introduced Gy interface to handle 5G throughput for dedicated bearers.

When the maximum bandwidth value set for UL/DL traffic is higher than 4294967295 bits per second, P-GW sets the "Max-Requested-Bandwidth-UL/DL" AVP to its upper limit 4294967295 and sets the "Extended-Max-Requested-BW-UL/DL" to the required bandwidth value in kilobits per second in CCR-I/CCR-U messages. The same principal applies for "Extended-GBR-UL/DL" and "Extended-APN-AMBR-UL/DL".

5G NSA feature supports Gy dcca-custom1, dcca-custom7, dcca-custom8, standard dcca-custom13 and dcca-custom26 dictionaries.

Gz (P-GW)

c

New sequence of container in PGWRecord for PGW-CDR to support RAN secondary RAT usage data report is introduced in Gz interface. AVPs "listOfRANSecondaryRATUsageReports" and "RANSecondaryRATUsageReport" are introduced.

New AVPs "Extended-Max-Requested-BW-UL", "Extended-Max-Requested-BW-DL", "Extended-GBR-UL", "Extended-GBR-DL", "Extended-APN-AMBR-UL" and "Extended-APN-AMBR-DL" are introduced over Gz interface as part of existing "EPCQoSInformation" AVP to handle 5G throughput for default and dedicated bearers.

Rf (P-GW)

New AVPs "RAN-Secondary-RAT-Usage-Report" which is grouped type to support secondary RAT usage data report values is introduced in Rf interface. This contains the volume count as reported by the RAN for the secondary RAT(separated for uplink and downlink) including the time of the report.

AVPs "Extended-Max-Requested-BW-UL", "Extended-Max-Requested-BW-DL", "Extended-GBR-UL", "Extended-GBR-DL", "Extended-APN-AMBR-UL" and "Extended-APN-AMBR-DL" are introduced over Rf interface to handle 5G throughput for default and dedicated bearers.

Gz(S-GW)

New sequence of container in SGWRecord for SGW-CDR to support RAN secondary RAT usage data report is introduced in Gz interface. AVPs "listOfRANSecondaryRATUsageReports" and "RANSecondaryRATUsageReport" are introduced.

New AVPs "Extended-Max-Requested-BW-UL", "Extended-Max-Requested-BW-DL", "Extended-GBR-UL", "Extended-GBR-DL", "Extended-APN-AMBR-UL" and "Extended-APN-AMBR-DL" are introduced over Gz interface as part of existing "EPCQoSInformation" AVP to handle 5G throughput for default and dedicated bearers.

Limitations

This section describes the known limitations for 5G NSA feature

- 5G NSA supports Gx standard dictionary (r8-gx-standard), dpca-custom11, dpca-custom15, dpca-custom17, dpca-custom19, and dpca-custom23.
- 5G NSA has been implemented for Gy dictionaries—dcca-custom1, dcca-custom7, dcca-custom8, standard dcca-custom13 and dcca-custom26. In order to support NSA for other Gx and Gy dictionaries, dynamic dictionary must be built. Contact your Cisco Account representative for more details.
- Secondary RAT usage data report will not carry start or end time values prior to “00:00:00 UTC, Thursday, 1 January 1970”.

Flows

This section describes the following call flows related to the DCNR feature.

Initial Registration by DCNR Capable UE

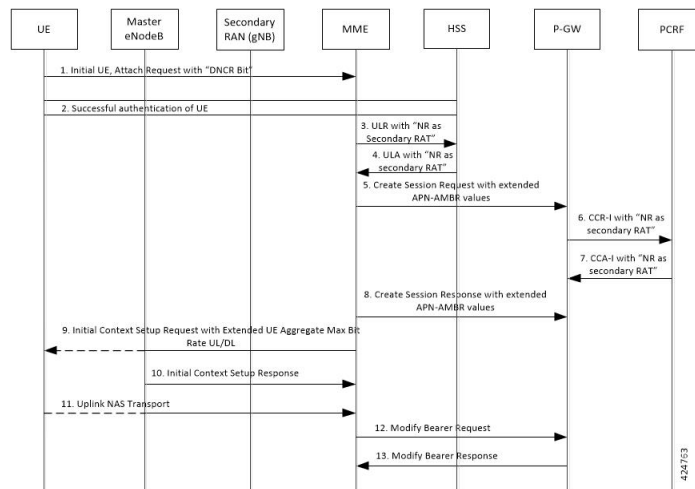

Step	Description
1	The DCNR capable UE sets the "DCNR bit" in the NAS message "Attach Request" of "UE Network Capability" IE.
2	MME successfully authenticates the UE.
3	As part of the authorization process, while sending ULR to HSS, MME advertises the DCNR support by sending “NR as Secondary RAT” feature bit in “Feature-List-ID-2”.

Step	Description
4	<p>HSS sends ULA by advertising the DCNR by sending "NR as Secondary RAT" feature bit in "Feature-List-ID-2" and sends Max-Requested-Bandwidth-UL as 4294967295 bps, Max-Requested-Bandwidth-DL as 4294967295 bps and the extended bandwidth values in new AVPs "Extended-Max-Requested-BW-UL" and "Extended-Max-Requested-BW-DL".</p> <p>If HSS determines that the UE is not authorized for DCNR services, HSS sends Subscription-Data with "Access-Restriction" carrying "NR as Secondary RAT Not Allowed".</p>
5	<p>MME sends Create Session Request with the extended APN-AMBR values in existing AMBR IE. As the APN-AMBR values in GTP-v2 interface are encoded in kbps, the existing AMBR IE handles the 5G NSA bit rates.</p>
6	<p>P-W sends CCR-I to PCRF advertising the DCNR by sending "Extended-BW-NR" feature bit in "Feature-List-ID-2". P-GW also sends "APN-Aggregate-Max-Bitrate-UL" as 4294967295 bps, "APN-Aggregate-Max-Bitrate-DL" as 4294967295 bps and the extended bandwidth values in new AVPs "Extended-APN-AMBR-UL" and "Extended-APN-AMBR-DL".</p>
7	<p>PCRF sends CCA-I advertising the DCNR by sending the "Extended-BW-NR" feature bit in "Feature-List-ID-2". PCRF also sends "APN-Aggregate-Max-Bitrate-UL" as 4294967295 bps and "APN-Aggregate-Max-Bitrate-DL" as 4294967295 bps and the extended bandwidth values in new "AVPs Extended-APN-AMBR-UL" and "Extended-APN-AMBR-DL". PCRF offers the same extended APN-AMBR values requested by PCEF or modify the extended APN-AMBR values. P-GW enforces the APN-AMBR values accordingly.</p>
8	<p>P-GW honors the APN-AMBR values as offered by PCRF and sends the extended APN-AMBR values in existing IE APN-AMBR in the Create Session Response message.</p>

Step	Description
9	<p>MME computes the UE-AMBR values and sends the extended UE-AMBR values in new IEs "Extended UE Aggregate Maximum Bit Rate Downlink" and "Extended UE Aggregate Maximum Bit Rate Uplink" by setting the legacy "UE AMBR Uplink" and "UE AMBR Downlink" values to the maximum allowed value 10000000000 bps(10 Gbps) in Initial Context Setup Request.</p> <p>MME sends the APN-AMBR values up to 65.2 Gbps in existing IE APN-AMBR in NAS Activate Default EPS Bearer Context Request – Attach Accept. If the APN-AMBR values are beyond 65.2 Gbps, MME sends the extended APN-AMBR values in new IE "Extended APN aggregate maximum bit rate."</p> <p>If ULA is received with "Access-Restriction" carrying "NR as Secondary RAT Not Allowed", MME sends the "Initial Context Setup Request" with "NR Restriction" bit set in "Handover Restriction List" IE. Also MME sets the "RestrictDCNR" bit to "Use of dual connectivity with NR is restricted" in the EPS network feature support IE of the Attach Accept message. Accordingly, UE provides the indication that DCNR is restricted to the upper layers.</p> <p>If DCNR is not configured at MME service or call control profile level, MME sets the RestrictDCNR bit to "Use of dual connectivity with NR is restricted" in the EPS network feature support IE of the Attach Accept message. Accordingly, UE provides the indication that DCNR is restricted to the upper layers.</p>
10	eNodeB sends the Initial Context Setup Response message. If master eNodeB determines to establish the bearer on secondary eNodeB, F-TEID of secondary eNodeB may be sent in this step (Transport layer address and TEID of secondary eNodeB). It is transparent to MME if the bearer is established on master eNodeB or secondary eNodeB.
11	eNodeB sends Uplink NAS Transport with NAS message Attach Complete - Activate Default EPS Bearer Context Accept.
12	MME sends Modify Bearer Request to S-GW with S1-U FTEID details as received in the Initial Context Setup Response message.
13	MME receives the Modify Bearer Response message from S-GW.

Supported Standards

Cisco's implementation of the 5G NSA complies with the following standards:

- 3GPP 23.401 Release 15.2.0 - General Packet Radio Service (GPRS) enhancements for Evolved Universal Terrestrial Radio Access Network (E-UTRAN) access
- 3GPP 29.212 Release 15.2.0 - Policy and Charging Control (PCC)
- 3GPP 29.274 Release 15.2.0 - 3GPP Evolved Packet System (EPS); Evolved General Packet Radio Service (GPRS) Tunneling Protocol for Control plane (GTPv2-C); Stage 3
- 3GPP 32.299 Release 15.2.0 - Charging Management; Diameter Charging Applications
- 3GPP 32.298 Release 15.2.0 - Charging Management; Charging Data Record (CDR) parameter description

Configuring 5G NSA for SAEGW

This section describes how to configure 5G NSA to support SAEGW.

Configuring 5G NSA on SAEGW involves:

- [Enabling DCNR in P-GW Service, on page 252](#)
- [Configuring Bearer Duration Statistics for URLLC QCI, on page 252](#)
- [Configuring EGTPC QCI Statistics for URLLC QCI, on page 253](#)
- [Configuring Extended Bandwidth with New Radio, on page 253](#)
- [Configuring Network-Initiated Setup/Teardown Events for URLLC QCI, on page 254](#)
- [Configuring URLLC QCI in APN Configuration, on page 254](#)
- [Configuring URLCC QCI In Charging Action, on page 255](#)
- [Configuring URLCC QCI in QCI QOS Mapping Table , on page 255](#)

Enabling DCNR in P-GW Service

Use the following configuration to enable Dual Connectivity with New Radio (DCNR) to support 5G Non Standalone (NSA).

```
configure
  context context_name
    pgw-service service_name
      [ no ] dcnr
    end
```

NOTES:

- **pgw-service** *service_name*: Creates an P-GW service or configures a existing P-GW service. *service_name* must be an alphanumeric string of 1 to 63 characters.
- **no**: Disables the DCNR configuration.
- The **dcnr** CLI command is disabled by default.

Configuring Bearer Duration Statistics for URLLC QCI

Use the following configuration to configure QCI based duration statistics for URLLC QCI.

```
configure
  context context_name
    apn apn_name
      [ no ] bearer-duration-stats qci qci_val
    end
```

NOTES:

- **apn** *apn_name*: Creates or deletes Access Point Name (APN) templates and enters the APN Configuration Mode within the current context. *apn_name* specifies a name for the APN template as an alphanumeric string of 1 through 62 characters that is case insensitive.
- **bearer-duration-stats**: Enables or disables per QCI call duration statistics for dedicated bearers.
- **qci** *qci_val*: Specifies the QoS Class Identifier. *qci_val* must be an integer between 1 to 9, 80, 82, and 83.
- **no**: Disables per QCI call duration statistics.

Configuring EGTPC QCI Statistics for URLLC QCI

Use the following configuration to configure QCI based EGTPC QCI statistics for URLLC QCI.

```

configure
  context context_name
    apn apn_name
      [ no ] egtpc-qci-stats { qci80 | qci82 | qci83 }
      default egtpc-qci-stats
    end

```

Notes:

- **apn** *apn_name*: Creates or deletes Access Point Name (APN) templates and enters the APN Configuration Mode within the current context. *apn_name* specifies a name for the APN template as an alphanumeric string of 1 through 62 characters that is case insensitive.
- **egtpc-qci-stats**: Enables/Disables an APN candidate list for the **apn-expansion** bulkstats schema.
- **qci80**: Configure apn-qci-egtpc statistics for QCI 80.
- **qci82**: Configure apn-qci-egtpc statistics for QCI 82.
- **qci83**: Configure apn-qci-egtpc statistics for QCI 83.
- **no**: Disables APN candidate list(s) for the apn-expansion bulkstats schema.
- **default**: Disables an APN candidate list for the apn-expansion bulkstats schema.

Configuring Extended Bandwidth with New Radio

Use the following configuration to configure extended bandwidth with new radio in IMS authorization service mode.

```

configure
  context context_name
    ims-auth-service ims_auth_service_name
      policy-control
        diameter encode-supported-features extended-bw-newradio
        [ no ] diameter encode-supported-features
      end

```

NOTES:

- **ims-auth-service** *ims_auth_service_name*: Creates an IMS authentication service. *ims_auth_service_name* must be an alphanumeric string of 1 through 63 characters.
- **policy-control**: Configures Diameter authorization and policy control parameter for IMS authorization.
- **extended-bw-newradio**: Enables extended bandwidth with New-Radio feature.
- **diameter encode-supported-features**: Enables/Disables encoding and sending of Supported-Features AVP.
- **no**: Removes the configuration of extended bandwidth with new-radio in IMS authorization service mode.

Configuring Network-Initiated Setup/Teardown Events for URLLC QCI

Use the following configuration to configure network initiated setup or teardown events KPI for URLLC QCI.

```
configure
  transaction-rate nw-initiated-setup-teardown-events qci qci_val
  [ default | no ] transaction-rate nw-initiated-setup-teardown-events
qci
end
```

NOTES:

- **transaction-rate nw-initiated-setup-teardown-events**: Enables operators to set the Quality of Class Identifier (QCI) value for use in tracking Network Initiated Setup/Tear down Events per Second key performance indicator (KPI) information.
- **qci** *qci_val*: Specifies the QoS Class Identifier. *qci_val* must be an integer between 1 to 9, 65, 66, 69, 70, 80, 82, 83, and 128 to 254.
- **no**: Disables the collection of network-initiated setup/teardown events for the specified QCI value.
- **default**: Returns the setting to its default value. The default is for network-initiated setup/teardown events to be tracked for all supported QCI values.

Configuring URLLC QCI in APN Configuration

Use the following configuration to configure URLLC QCI in the APN Configuration mode.

```
configure
  context context_name
  apn apn_name
  qos rate-limit direction { downlink | uplink } qci qci_val
  no qos rate-limit direction { downlink | uplink }
end
```

NOTES:

- **apn** *apn_name*: Allows to specify the APN name as a condition. *apn_name* must be an alphanumeric string of 1 through 63 characters.

- **qos rate-limit**: Configures the action on a subscriber traffic flow that violates or exceeds the peak/committed data rate under traffic shaping and policing functionality.
- **direction { downlink | uplink }**: Specifies the direction of traffic on which this QoS configuration needs to be applied.
 - **downlink**: Apply the specified limits and actions to the downlink.
 - **uplink**: Apply the specified limits and actions to the uplink.
- **qci qci_val**: Specifies the QoS Class Identifier. *qci_val* must be an integer between 1 to 9, 80, 82, and 83.
- **no**: Disables the QoS data rate limit configuration for the APN.

Configuring URLCC QCI In Charging Action

Use the following configuration to configure URLCC QCI in the Charging Action Configuration mode.

```
configure
  active-charging service service_name
    charging-action charging_action_name
      qos-class-identifier qos_class_identifier
    no qos-class-identifier
  end
```

NOTES:

- **active-charging service service_name**: Specifies name of the active charging service. *service_name* must be an alphanumeric string of 1 through 15 characters.
- **charging-action charging_action_name**: Creates a charging action. *qos_class_identifier* must be an alphanumeric string of 1 through 63 characters.
- **qos-class-identifier qos_class_identifier**: Specifies the QoS Class Identifier. *qos_class_identifier* must be an integer between 1 to 9, 65, 66, 69, 70, 80, 82, and 83.
- **no**: Disables the QoS Class Identifier.

Configuring URLCC QCI in QCI QOS Mapping Table

Use the following configuration to configure URLCC QCI in the QCI QOS Mapping Table.

```
configure
  qci-qos-mapping name
    [ no ] qci qci_value
  end
```

NOTES:

- **qci-qos-mapping name**: Specifies the map name. *name* must be an alphanumeric string of 1 through 63 characters.
- **qci qci_val**: Specifies the QoS Class Identifier. *qci_val* must be an integer between 1 to 9, 65, 66, 69, 70, 80, 82, and 83.

- **no**: Disables the QCI value.

Monitoring and Troubleshooting

This section provides information regarding show commands and bulk statistics available to monitor and troubleshoot the 5G NSA feature.

Show Commands and Outputs

This section provides information on show commands and their corresponding outputs for the DCNR feature.

show pgw-service name

The output of this command includes the "DCNR" field to indicate if the DCNR feature is enabled or disabled at P-GW service.

show ims-authorization service name

The output of this command includes the following fields:

Diameter Policy Control:

Supported Features:

- extended-bw-nr

show gtpu statistics

The output of this command includes the following fields:

- Uplink Packets — Displays the total number of QCI 80, QCI 82, and QCI 83 uplink packets.
- Uplink Bytes — Displays the total number of QCI 80, QCI 82, and QCI 83 uplink bytes.
- Downlink Packets — Displays the total number of QCI 80, QCI 82, and QCI 83 downlink packets.
- Downlink Bytes — Displays the total number of QCI 80, QCI 82, and QCI 83 downlink bytes.
- Packets Discarded — Displays the total number of discarded QCI 80, QCI 82, and QCI 83 packets.
- Bytes Discarded — Displays the total number of discarded QCI 80, QCI 82, and QCI 83 bytes.

show apn statistics all

The output of this command includes the following fields:

4G Bearers Released By Reasons:

Admin disconnect — Displays dedicated bearers released due to administration clear from P-GW for QCI 80, QCI 82, and QCI 83.

- Bearer Active — Displays the total number for QCI 80, QCI 82, and QCI 83 active bearers.
- Bearer setup — Displays the total number for QCI 80, QCI 82, and QCI 83 bearers setup.

- Bearer Released — Displays the total number for QCI 80, QCI 82, and QCI 83 released bearers.
- Bearer Rejected —
- Uplink Bytes Forwarded — Displays the total number for QCI 80, QCI 82, and QCI 83 uplink packets forwarded.
- Uplink pkts forwarded — Displays the total number for QCI 80, QCI 82, and QCI 83 downlink packets forwarded.
- Uplink Bytes dropped — Displays the total number for QCI 80, QCI 82, and QCI 83 uplink bytes forwarded.
- Downlink Bytes forwarded — Displays the total number for QCI 80, QCI 82, and QCI 83 downlink bytes forwarded.
- Uplink pkts dropped — Displays the total number for QCI 80, QCI 82, and QCI 83 uplink packets dropped.
- Downlink Bytes dropped — Displays the total number for QCI 80, QCI 82, and QCI 83 downlink bytes dropped.
- Uplink Bytes dropped(MBR Excd) — Displays the total number for QCI 80, QCI 82, and QCI 83 uplink bytes dropped due to MBR being exceeded.
- Uplink pkts dropped(MBR Excd) — Displays the total number for QCI 80, QCI 82, and QCI 83 uplink packets dropped due to MBR being exceeded.
- Downlink pkts forwarded — Displays the total number for QCI 80, QCI 82, and QCI 83 downlink packets forwarded.
- Downlink pkts dropped — Displays the total number for QCI 80, QCI 82, and QCI 83 downlink packets dropped.
- Downlink Bytes dropped(MBR Excd) — Displays the total number for QCI 80, QCI 82, and QCI 83 downlink bytes dropped due to MBR being exceeded.
- Downlink pkts dropped(MBR Excd) — Displays the total number for QCI 80, QCI 82, and QCI 83 downlink packets dropped due to MBR being exceeded.

show pgw-service statistics all verbose

The output of this command includes the following fields:

Bearers By QoS characteristics:

- Active — Displays the total number of active bearers for QCI 80, QCI 82, and QCI 83.
- Released — Displays the total number of bearers released for QCI 80, QCI 82, and QCI 83.
- Setup — Displays the total number of bearers setup for QCI 80, QCI 82, and QCI 83.

Data Statistics Per PDN-Type:

Uplink:

- Packets — Displays the total number of uplink packets forwarded for QCI 80, QCI 82, and QCI 83.
- Bytes — Displays the total number of uplink bytes forwarded for QCI 80, QCI 82, and QCI 83.

- Dropped Packets — Displays the total number of uplink packets dropped for QCI 80, QCI 82, and QCI 83.
- Dropped Bytes — Displays the total number of uplink bytes dropped for QCI 80, QCI 82, and QCI 83.

Downlink:

- Packets — Displays the total number of downlink packets forwarded for QCI 80, QCI 82, and QCI 83.
- Bytes — Displays the total number of downlink bytes forwarded for QCI 80, QCI 82, and QCI 83.
- Dropped Packets — Displays the total number of downlink packets dropped for QCI 80, QCI 82, and QCI 83.
- Dropped Bytes — Displays the total number of downlink bytes dropped for QCI 80, QCI 82, and QCI 83.

DCNR PDN Statistics:

- Active — The total number of current active P-GW DCNR PDNs.
- Setup — The total number of P-GW PDNs that are setup as a DCNR PDN.
- Released — The total number of P-GW DCNR PDNs released.

show sgw-service statistics all verbose

The output of this command includes the following fields:

Bearers By QoS characteristics:

- Active — Displays the total active EPS Bearers for QCI 80, QCI 82, and QCI 83.
- Released — Displays the total number of EPS Bearers released for QCI 80, QCI 82, and QCI 83.
- Setup — Displays the total number of EPS bearers setup for QCI 80, QCI 82, and QCI 83.
- Modified — Displays the total number of EPS bearers modified for QCI 80, QCI 82, and QCI 83.

Dedicated Bearers Released By Reason:

- P-GW Initiated — Displays the total number of dedicated EPS bearers for QCI 80, QCI 82, and QCI 83 released with the reason P-GW initiated on the S-GW.
- S1 Error Indication — Displays the total number of dedicated EPS bearers for QCI 80, QCI 82, and QCI 83 released with the reason S1 error indication on the S-GW.
- S5 Error Indication — Displays the total number of dedicated EPS bearers for QCI 80, QCI 82, and QCI 83 released with the reason S5 error indication on the S-GW.
- S4 Error Indication — Displays the total number of dedicated EPS bearers for QCI 80, QCI 82, and QCI 83 released with the reason S4 error indication on the S-GW.
- S12 Error Indication — Displays the total number of dedicated EPS bearers for QCI 80, QCI 82, and QCI 83 released with the reason S12 error indication on the S-GW.
- Local — Displays the total number of dedicated EPS bearers for QCI 80, QCI 82, and QCI 83 released with the reason local error indication on the S-GW.

- PDN Down — Displays the total number of dedicated EPS bearers for QCI 80, QCI 82, and QCI 83 released due to PDN cleanup on the S-GW.
- Path Failure S1-U — Displays the total number of dedicated EPS bearers for QCI 80, QCI 82, and QCI 83 released with the reason S1-U path failure on the S-GW.
- Path Failure S5-U — Displays the total number of dedicated EPS bearers for QCI 80, QCI 82, and QCI 83 released with the reason S5-U path failure on the S-GW.
- Path Failure S5 — Displays the total number of dedicated EPS bearers for QCI 80, QCI 82, and QCI 83 released with the reason S5 path failure on the S-GW.
- Path Failure S11 — Displays the total number of dedicated bearers for QCI 80, QCI 82, and QCI 83 released due to path failure on the S11 interface.
- Path Failure S4-U — Displays the total number of dedicated bearers for QCI 80, QCI 82, and QCI 83 released due to path failure on S4-U interface.
- Path Failure S12 — Displays the total number of dedicated bearers for QCI 80, QCI 82, and QCI 83 released due to path failure on S12 interface.
- Inactivity Timeout — Displays the total number of dedicated bearers for QCI 80, QCI 82, and QCI 83 released due to the inactivity timeout.
- Other — Displays the total number of dedicated bearers for QCI 80, QCI 82, and QCI 83 released due to other reasons.

Data Statistics Per Interface:

S1-U/S11-U/S4-U/S12/S5-U/S8-U Total Data Statistics:

Uplink:

- Packets — Displays the total number of uplink data packets received by the S-GW for a bearer with QCI 80, QCI 82, and QCI 83.
- Bytes — Displays the total number of uplink data bytes received by the S-GW for a bearer with QCI 80, QCI 82, and QCI 83.
- Dropped Packets — Displays the total number of uplink data packets dropped by the S-GW for a bearer with a QCI 80, QCI 82, and QCI 83.
- Dropped Bytes — Displays the total number of uplink data bytes dropped by the S-GW for a bearer with QCI 80, QCI 82, and QCI 83.

Downlink:

- Packets — Displays the total number of downlink data packets received by the S-GW for a bearer with QCI 80, QCI 82, and QCI 83.
- Bytes — Displays the total number of downlink data bytes received by the S-GW for a bearer with QCI 80, QCI 82, and QCI 83.
- Dropped Packets — Displays the total number of downlink data packets dropped by the S-GW for bearer with QCI 80, QCI 82, and QCI 83.
- Dropped Bytes — Displays the total number of downlink data bytes dropped by the S-GW for a bearer with QCI 80, QCI 82, and QCI 83.

DCNR PDN Statistics:

- Active — The total number of current active S-GW DCNR PDNs.
- Setup — The total number of S-GW PDNs that are setup as a DCNR PDN.
- Released — The total number of S-GW DCNR PDNs released.

show saegw-service statistics all verbose

The output of this command includes the following fields:

Bearers By QoS characteristics:

- Active — Displays the total number of QCI 80, QCI 82, and QCI 83 active bearers.
- Released — Displays the total number of QCI 80, QCI 82, and QCI 83 released bearers.
- Setup — Displays the total number of QCI 80, QCI 82, and QCI 83 bearers setup.

Data Statistics Per PDN-Type:

Uplink:

- Packets — Displays the total number of QCI 80, QCI 82, and QCI 83 uplink packets forwarded.
- Bytes — Displays the total number of QCI 80, QCI 82, and QCI 83 uplink bytes forwarded.
- Dropped Packets — Displays the total number of QCI 80, QCI 82, and QCI 83 uplink packets dropped.
- Dropped Bytes — Displays the total number of QCI 80, QCI 82, and QCI 83 uplink bytes dropped.

Downlink:

- Packets — Displays the total number of QCI 80, QCI 82, and QCI 83 downlink packets forwarded.
- Bytes — Displays the total number of QCI 80, QCI 82, and QCI 83 downlink bytes forwarded.
- Dropped Packets — Displays the total number of QCI 80, QCI 82, and QCI 83 downlink packets dropped.
- Dropped Bytes — Displays the total number of QCI 80, QCI 82, and QCI 83 downlink bytes dropped.

DCNR PDNs:

Colocated PDNs:

- Active — The total number of currently active SAEGW collapsed DCNR PDNs.
- Setup — The total number of SAEGW collapsed PDNs that are setup as a DCNR PDN.
- Released — The total number of SAEGW collapsed DCNR PDNs released.

PGW-Anchor PDNs:

- Active — The total number of currently active P-GW anchored DCNR PDNs.
- Setup — The total number of P-GW anchored PDNs that are setup as a DCNR PDN.
- Released — The total number of P-GW anchored DCNR PDNs that are released.

SGW-Anchor PDNs:

- Active — The total number of current active S-GW anchored DCNR PDNs.
- Setup — The total number of S-GW anchored PDNs that are setup as a DCNR PDN.
- Released — The total number of S-GW anchored DCNR PDNs that are released.

Bulk Statistics

The following statistics are added in support of the 5G NSA feature.

APN Schema

The following 5G NSA feature related bulk statistics are available in the APN schema.

Bulk Statistics	Description
qci80-actbear	The total number of QCI80 active bearers.
qci82-actbear	The total number of QCI82 active bearers.
qci83-actbear	The total number of QCI83 active bearers.
qci80-setupbear	The total number of QCI80 bearers setup.
qci82-setupbear	The total number of QCI82 bearers setup.
qci83-setupbear	The total number of QCI83 bearers setup.
qci80-relbear	The total number of QCI80 released bearers.
qci82-relbear	The total number of QCI82 released bearers.
qci83-relbear	The total number of QCI83 released bearers.
qci80-uplinkpkt-fwd	The total number of QCI80 uplink packets forwarded.
qci82-uplinkpkt-fwd	The total number of QCI82 uplink packets forwarded.
qci83-uplinkpkt-fwd	The total number of QCI83 uplink packets forwarded.
qci80-dwlinkpkt-fwd	The total number of QCI80 downlink packets forwarded.
qci82-dwlinkpkt-fwd	The total number of QCI82 downlink packets forwarded.
qci83-dwlinkpkt-fwd	The total number of QCI83 downlink packets forwarded.
qci80-uplinkbyte-fwd	The total number of QCI80 uplink bytes forwarded.
qci82-uplinkbyte-fwd	The total number of QCI82 uplink bytes forwarded.
qci83-uplinkbyte-fwd	The total number of QCI83 uplink bytes forwarded.

Bulk Statistics	Description
qci80-dwlinkbyte-fwd	The total number of QCI80 downlink bytes forwarded.
qci82-dwlinkbyte-fwd	The total number of QCI82 downlink bytes forwarded.
qci83-dwlinkbyte-fwd	The total number of QCI83 downlink bytes forwarded.
qci80-uplinkpkt-drop	The total number of QCI80 uplink packets dropped.
qci82-uplinkpkt-drop	The total number of QCI82 uplink packets dropped.
qci83-uplinkpkt-drop	The total number of QCI83 uplink packets dropped.
qci80-dwlinkpkt-drop	The total number of QCI80 downlink packets dropped.
qci82-dwlinkpkt-drop	The total number of QCI82 downlink packets dropped.
qci83-dwlinkpkt-drop	The total number of QCI83 downlink packets dropped.
qci80-uplinkbyte-drop	The total number of QCI80 uplink bytes dropped.
qci82-uplinkbyte-drop	The total number of QCI82 uplink bytes dropped.
qci83-uplinkbyte-drop	The total number of QCI83 uplink bytes dropped.
qci80-dwlinkbyte-drop	The total number of QCI80 downlink bytes dropped.
qci82-dwlinkbyte-drop	The total number of QCI82 downlink bytes dropped.
qci83-dwlinkbyte-drop	The total number of QCI83 downlink bytes dropped.
qci80-uplinkpkt-drop-mbrexcd	The total number of QCI80 uplink packets dropped due to MBR being exceeded.
qci82-uplinkpkt-drop-mbrexcd	The total number of QCI82 uplink packets dropped due to MBR being exceeded.
qci83-uplinkpkt-drop-mbrexcd	The total number of QCI83 uplink packets dropped due to MBR being exceeded.
qci80-dwlinkpkt-drop-mbrexcd	The total number of QCI80 downlink packets dropped due to MBR being exceeded.
qci82-dwlinkpkt-drop-mbrexcd	The total number of QCI82 downlink packets dropped due to MBR being exceeded.
qci83-dwlinkpkt-drop-mbrexcd	The total number of QCI83 downlink packets dropped due to MBR being exceeded.

P-GW Schema

The following 5G NSA feature related bulk statistics available in the P-GW schema.

Bulk Statistics	Description
pgw-anchor-pdns-dcnr-current-active	The total number of currently active P-GW anchored DCNR PDNs.
pgw-anchor-pdns-dcnr-cumulative-activated	The total number of P-GW anchored PDNs that are setup as DCNR PDN.
pgw-anchor-pdns-dcnr-cumulative-deactivated	The total number of P-GW anchored PDNs that were either released or degrades to a non-DNCR PDN.
sessstat-pdn-dcnr-current-active	Session Statistics - DCNR PDN-Type Statistics - Current Active.
sessstat-pdn-dcnr-cumulative-activated	Session Statistics - DCNR PDN-Type Statistics - Cumulative PDNs Activated.
sessstat-pdn-dcnr-cumulative-deactivated	Session Statistics - DCNR PDN-Type Statistics - Cumulative PDNs Deactivated.

SAEGW Schema

The following 5G NSA feature related bulk statistics available in the SAEGW schema.

Bulk Statistics	Description
saegw-collocated-pdns-dcnr-current-active	The total number of currently active SAEGW collapsed DCNR PDNs.
saegw-collocated-pdns-dcnr-cumulative-activated	The total number of SAEGW collapsed PDNs that are setup as a DCNR PDN.
saegw-collocated-pdns-dcnr-cumulative-deactivated	The total number of SAEGW collapsed DCNR PDNs released.

S-GW Schema

The following 5G NSA feature related bulk statistics available in the S-GW schema.

Bulk Statistics	Description
sessstat-pdn-dcnr-current-active	The total number of currently active S-GW DCNR PDNs.
sessstat-pdn-dcnr-cumulative-activated	The total number of S-GW PDNs that are setup as a DCNR PDN.
sessstat-pdn-dcnr-cumulative-deactivated	The total number of S-GW DCNR PDNs released.
sgw-anchor-pdns-dcnr-current-active	The total number of currently active S-GW anchored DCNR PDNs.
sgw-anchor-pdns-dcnr-cumulative-activated	The total number of S-GW anchored PDNs that are setup as a DCNR PDN.

Bulk Statistics	Description
sgw-anchor-pdns-dcnr-cumulative-deactivated	The total number of S-GW anchored DCNR PDNs that are released.

System Schema

The following 5G NSA feature related bulk statistics are available in the System schema.

Bulk Statistics	Description
sess-bearerdur-5sec-qci80	The current number of bearer sessions with a duration of 5 seconds and having a QCI of 80.
sess-bearerdur-5sec-qci82	The current number of bearer sessions with a duration of 5 seconds and having a QCI of 82.
sess-bearerdur-5sec-qci83	The current number of bearer sessions with a duration of 5 seconds and having a QCI of 83.
sess-bearerdur-10sec-qci80	The current number of bearer sessions with a duration of 10 seconds and having a QCI of 80.
sess-bearerdur-10sec-qci82	The current number of bearer sessions with a duration of 10 seconds and having a QCI of 82.
sess-bearerdur-10sec-qci83	The current number of bearer sessions with a duration of 10 seconds and having a QCI of 83.
sess-bearerdur-30sec-qci80	The current number of bearer sessions with a duration of 30 seconds and having a QCI of 80.
sess-bearerdur-30sec-qci82	The current number of bearer sessions with a duration of 30 seconds and having a QCI of 82.
sess-bearerdur-30sec-qci83	The current number of bearer sessions with a duration of 30 seconds and having a QCI of 83.
sess-bearerdur-1min-qci80	The current number of bearer sessions with a duration of 1 minute and having a QCI of 80.
sess-bearerdur-1min-qci82	The current number of bearer sessions with a duration of 1 minute and having a QCI of 82.
sess-bearerdur-1min-qci83	The current number of bearer sessions with a duration of 1 minute and having a QCI of 83.
sess-bearerdur-2min-qci80	The current number of bearer sessions with a duration of 2 minutes and having a QCI of 80.
sess-bearerdur-2min-qci82	The current number of bearer sessions with a duration of 2 minutes and having a QCI of 82.

Bulk Statistics	Description
sess-bearerdur-2min-qci83	The current number of bearer sessions with a duration of 2 minutes and having a QCI of 83.
sess-bearerdur-5min-qci80	The current number of bearer sessions with a duration of 5 minutes and having a QCI of 80.
sess-bearerdur-5min-qci82	The current number of bearer sessions with a duration of 5 minutes and having a QCI of 82.
sess-bearerdur-5min-qci83	The current number of bearer sessions with a duration of 5 minutes and having a QCI of 83.
sess-bearerdur-15min-qci80	The current number of bearer sessions with a duration of 15 minutes and having a QCI of 80.
sess-bearerdur-15min-qci82	The current number of bearer sessions with a duration of 15 minutes and having a QCI of 82.
sess-bearerdur-15min-qci83	The current number of bearer sessions with a duration of 15 minutes and having a QCI of 83.
sess-bearerdur-30min-qci80	The current number of bearer sessions with a duration of 30 minutes and having a QCI of 80.
sess-bearerdur-30min-qci82	The current number of bearer sessions with a duration of 30 minutes and having a QCI of 82.
sess-bearerdur-30min-qci83	The current number of bearer sessions with a duration of 30 minutes and having a QCI of 83.
sess-bearerdur-1hr-qci80	The current number of bearer sessions with a duration of 1 hour and having a QCI of 80.
sess-bearerdur-1hr-qci82	The current number of bearer sessions with a duration of 1 hour and having a QCI of 82.
sess-bearerdur-1hr-qci83	The current number of bearer sessions with a duration of 1 hour and having a QCI of 83.
sess-bearerdur-4hr-qci80	The current number of bearer sessions with a duration of 4 hours and having a QCI of 80.
sess-bearerdur-4hr-qci82	The current number of bearer sessions with a duration of 4 hours and having a QCI of 82.
sess-bearerdur-4hr-qci83	The current number of bearer sessions with a duration of 4 hours and having a QCI of 83.
sess-bearerdur-12hr-qci80	The current number of bearer sessions with a duration of 12 hours and having a QCI of 80.
sess-bearerdur-12hr-qci82	The current number of bearer sessions with a duration of 12 hours and having a QCI of 82.

Bulk Statistics	Description
sess-bearerdur-12hr-qci83	The current number of bearer sessions with a duration of 12 hours and having a QCI of 83.
sess-bearerdur-24hr-qci80	The current number of bearer sessions with a duration of 24 hours and having a QCI of 80.
sess-bearerdur-24hr-qci82	The current number of bearer sessions with a duration of 24 hours and having a QCI of 82.
sess-bearerdur-24hr-qci83	The current number of bearer sessions with a duration of 24 hours and having a QCI of 83.
sess-bearerdur-over24hr-qci80	The current number of bearer sessions with a duration of over 24 hours and having a QCI of 80.
sess-bearerdur-over24hr-qci82	The current number of bearer sessions with a duration of over 24 hours and having a QCI of 82.
sess-bearerdur-over24hr-qci83	The current number of bearer sessions with a duration of over 24 hours and having a QCI of 83.
sess-bearerdur-2day-qci80	The current number of bearer sessions with a duration of 2 days and having a QCI of 80.
sess-bearerdur-2day-qci82	The current number of bearer sessions with a duration of 2 days and having a QCI of 82.
sess-bearerdur-2day-qci83	The current number of bearer sessions with a duration of 2 days and having a QCI of 83.
sess-bearerdur-4day-qci80	The current number of bearer sessions with a duration of 4 days and having a QCI of 80.
sess-bearerdur-4day-qci82	The current number of bearer sessions with a duration of 4 days and having a QCI of 82.
sess-bearerdur-4day-qci83	The current number of bearer sessions with a duration of 4 days and having a QCI of 83.
sess-bearerdur-5day-qci80	The current number of bearer sessions with a duration of 5 days and having a QCI of 80.
sess-bearerdur-5day-qci82	The current number of bearer sessions with a duration of 5 days and having a QCI of 82.
sess-bearerdur-5day-qci83	The current number of bearer sessions with a duration of 5 days and having a QCI of 83.



CHAPTER 6

APN-Backoff Timer Support

This chapter describes StarOS support for the APN-Backoff Timer feature on the P-GW and SAEGW.

- [Feature Description, on page 267](#)
- [Configuring APN Backoff Timer Support on the P-GW/SAEGW, on page 269](#)
- [Monitoring the Feature, on page 270](#)

Feature Description

Previously, the P-GW did not distinguish signaling traffic from Delay Tolerant or Low Priority devices such as low priority machine-to-machine traffic.

The UE was able to indicate its device profile to the MME via NAS and Attach Request messages. The MME was able to pass this information to the P-GW via the Signaling Priority Indication Information Element (IE) on the S5 interface. Some UEs may not have supported the sending of the Signaling Priority Indication IE on the S5 interface to the P-GW. As a result, the P-GW could not distinguish between the signaling types. With the current release, the P-GW can distinguish between these signaling types.

In addition, during overload situations, the P-GW previously allowed new sessions from Low Access Priority Indicator (LAPI) devices and treated the traffic from LAPI devices with the same priority as the normal UEs. With the current StarOS release, during overload conditions, the P-GW can be configured to back off the traffic that is identified as LAPI. The identification is based on either the APN configuration or the Signaling Priority Indicator IE.

The backoff timer algorithm and the R12 GTP-C Load/Overload Control algorithm work together. This feature provides the benefit of rejecting low priority calls in turn allowing more bandwidth for high priority calls.

Functionality

The following functionality has been implemented to support the APN Backoff Timer functionality:

1. The Signaling Priority Indication IE on the S5 interface in the Create Session Request message identifies the low priority devices.
2. A LAPI APN can be configured. Any call landing on that APN is considered a LAPI call.
3. A back off timer value is configured in the APN. The backoff timer is sent in Create Session Response messages in the P-GW Back-Off Timer IE.

4. If the following conditions are met, the call is rejected with the cause APN Congestion. The configured backoff timer value is inserted in the Back Off Timer IE in the Create Session Response message.
 - Once an incoming call is identified as LAPI due to condition 1 or 2 above.
 - The P-GW is in the overload state.
 - The backoff timer is configured.
5. The M2M license must be present and enabled on the system. The GTP-C Load/Overload feature's configuration and backend reporting of overload parameters works with the M2M license.
6. In some dictionaries (for example, custom35) CDRs have a LAPI field for LAPI calls. This field is populated when the Signaling Priority Indication IE indicates that the call is a LAPI call. However, if the call is of type LAPI due to the LAPI APN configuration, then the CDR should not have the LAPI field.
7. Bulk statistics, counters, and statistics have been implemented at the APN and P-GW service level to show the number of calls rejected due to the APN Backoff Timer feature.

GTP-C Overload Feature and the M2M License

To detect whether the P-GW/SAEGW is in the overload state, the GTP-C Overload feature's framework has been used. It is tied to the M2M license so that only overload configuration and reporting of the overload state is enabled. The remaining overload features such as, sending the OCI towards the peers, throttling, and receiving OCIs from peers do not work. This leads to the following behavioral scenarios:

If a Call is a LAPI call and the Backoff Timer is Configured and the P-GW is in the Overload State:

- Only M2M License: Call is rejected with cause APN Congestion.
- Only GTP-C Overload Enabled: Not applicable as backoff timer cannot be configured.
- Both M2M and Overload Enabled: Call is rejected with cause APN Congestion. That is, LAPI takes priority over the GTP-C Load/Overload feature.

If a Call is Not LAPI or Backoff Timer is Not Configured and the P-GW is in the Overload State:

- Only M2M License Enabled: No impact. Call is accepted normally.
- Only Overload License Enabled: Call accepted. OCI will be sent in the Create Session Response message. Overload feature works normally.
- Both M2M and Overload Features Enabled: Call accepted. OCI is sent in the Create Session Response message. Overload feature works normally. Backoff Timer feature is ignored.

Licensing



Important

The APN Backoff Timer feature requires that the M2M license be enabled on the P-GW/SAEGW. Contact your Cisco account or support representative for licensing details.

Configuring APN Backoff Timer Support on the P-GW/SAEGW

This section describes how to configure APN Backoff Timer Support on the P-GW/SAEGW. The procedure consists of the following tasks:

1. Configuring LAPI Behavior
2. Configuring the Backoff Timer
3. Verifying the Configuration

Configuring LAPI Behavior

Use the following example to configure LAPI behavior:

```
configure
  apn apn_name
    pdn-behavior lapi
  end
```

To disable LAPI behavior:

```
configure
  apn apn_name
    no pdn-behavior
  end
```

Notes:

- **pdn-behavior lapi** configures the APN as a LAPI APN.
- **no pdn-behavior** disables the LAPI APN configuration.



Caution

Do not configure the emergency APN and **pdn-behavior lapi** settings in the same APN, as these two settings are mutually exclusive. If both settings are configured in the same APN the **pdn-behavior lapi** configuration takes priority. As a result, if both settings are configured and the system is overloaded, the call will be rejected.

To determine if both settings are configured in the same APN, execute the **show configuration error verbose** command in *Exec Mode*. The command output contains a warning if both settings are configured in the same APN.

Configuring the APN Backoff Timer and Jitter Values

The P-GW requires a fixed value and a jitter to introduce randomness in the Backoff Timer value that is returned to the MME for different sessions; this helps prevent a session storm after the Backoff Timer expiry.

Use the example below to configure the APN Backoff Timer and Jitter Values:

```
configure
  apn apn_name
```

```

    backoff timer-value seconds [ jitter seconds ]
end

```

To disable Backoff Timer functionality:

```

configure
  apn apn_name
    no backoff timer-value
  end

```

Notes:

- **backoff timer-value** *seconds* configures the backoff timer value, in seconds. Valid entry is an integer from 0 to 576000 seconds. There is no default setting.
- **jitter** *seconds* configures the jitter value, in seconds. Valid entry is from 0 to 1000 seconds. There is no default setting.

Verifying the Configuration

To verify the configuration:

In *Exec Mode*, issue the **show apn name** *apn_name* command, *apn_name* is the name of the APN for which you want to view configuration settings.

In the command output, look for the following fields:

- pdn behavior: *<lapi>* or *<no pdn-behavior>*
- Backoff Timer Value: *<seconds>* Jitter: *<seconds>*

Verify that the configuration settings are correct. If any of the settings are incorrect, use the configuration procedure in this chapter to reconfigure the incorrect setting(s).

Monitoring the Feature

This section provides information that enables operators to monitor the APN Backoff Timer feature.

Bulk Statistics

APN Schema

The following bulk statistics have been added to the APN Schema to support the APN Backoff Timer feature:

- rej-pdn-backofftimer

P-GW Schema

The following bulk statistic has been added to the P-GW schema to support the APN Backoff Timer feature.

- sessstat-rej-pdn-backofftimer

SAEGW Schema

The following bulk statistic has been added to the SAEGW schema to support the APN Backoff Timer feature:

- pgw-sessstat-rej-pdn-backofftimer

Show Command Output

This section describes the Exec Mode show commands and output available to monitor the APN Backoff Timer Support on the P-GW/SAEGW feature.

show apn name

The output of this command has been enhanced to show the configured backoff timer, jitter, and PDN behavior settings. These settings appear only if the M2M feature license is enabled.

- pdn behavior: lapi
- Backoff Timer Value: *<seconds>* Jitter: *<seconds>*

show apn statistics

The output of this command has been enhanced to indicate the number of PDNs rejected as a result of the configured backoff timer value.

- Number of PDNs rejected due to backoff algorithm:

show configuration apn name

The output of this command provides the operator with the current APN Backoff Timer settings.

- pdn-behavior lapi (if feature is enabled)
- backoff timer-value *<secs>* jitter *<secs>*

show pgw-service statistics

The output of this command has been enhanced to provide the total number of PDNs rejected due to the configured backoff timer value.

- PDNs Rejected By Reason:
 - APN-Backoff Timer

show session disconnect-reasons

The following disconnect reason has been added to support the APN Backoff Timer feature.

- apn-congestion

show session disconnect-reasons



CHAPTER

7

Backup and Recovery of Key KPI Statistics

This feature allows the backup of GGSN, P-GW, SAEGW, and/or S-GW counters for recovery of key KPI counter values after a session manager (SessMgr) restart.

This chapter includes the following information:

- [Feature Description, on page 273](#)
- [How It Works, on page 273](#)
- [Configuring Backup Statistics Feature, on page 275](#)

Feature Description

Before the Backup and Recovery of Key KPI Statistics feature was implemented, statistics were not backed up and could not be recovered after a SessMgr task restart. Due to this limitation, monitoring the KPI was a problem as the GGSN, P-GW, SAEGW, and S-GW would lose statistical information whenever task restarts occurred.

KPI calculation involves taking a delta between counter values from two time intervals and then determines the percentage of successful processing of a particular procedure in that time interval. When a SessMgr crashes and then recovers, the GGSN, P-GW, SAEGW, and S-GW lose the counter values - they are reset to zero. So, the KPI calculation in the next interval will result in negative values for that interval. This results in a dip in the graphs plotted using the KPI values, making it difficult for operations team to get a consistent view of the network performance to determine if there is a genuine issue or not.

This feature makes it possible to perform reliable KPI calculations even if a SessMgr restart occurs.

How It Works

A key set of counters used in KPI computation will be backed up for recovery if a SessMgr task restarts. The counters that will be backed up are determined by the KPIs typically used in several operator networks.

The backup of counters is enabled or disabled via configuration. The configuration specifies the product (GGSN, P-GW, SAEGW, and/or S-GW) for which counters will be backed up and also a time interval for the backup of the counters.

Architecture

When this feature is enabled (see *Configuring Backup Statistics Feature* below), the GGSN, P-GW, SAEGW, and/or S-GW only backs up the counters maintained at the SessMgr. The recovery function does not need to be configured or started as it occurs automatically as needed when the feature is enabled.

The counters are backed up to the AAAMgr that is paired with the SessMgr.

Checkpointing

Node-level statistics are checkpointed at AAAMgr. Once statistics are backed up for a specific product, all the associated services, such as eGTP-C and GTP-U statistics, are also checkpointed.

Recovery

When SessMgr restarts, recovery is performed by receiving all the stored statistics from the mapped AAAMgr and the recovered values are added to the backup counters maintained at per-service level. This will not impact session recovery time as the backed up counters are pushed to SessMgr only after session recovery is complete.

Since session recovery is complete, the session managers may start processing calls. In such cases, the counters will continue to be incremented. The recovered values of the corresponding counters will always be added to the existing counters. Gauge counters are checkpointed but not recovered.

Order of Statistics Collection

The upper limit of checkpoint messaging is a maximum of 1 MB. Before picking any node to checkpoint, available memory is checked. If memory is insufficient, the whole node is discarded.

Since there is 1 MB limit, nodes/statistics to checkpoint are prioritized as follows:

1. SAEGW statistics:
 - P-GW and S-GW service node-level statistics collected
2. P-GW service node configuration will store the following statistics:
 - P-GW, eGTP-C ingress, GTP-U ingress, per-interface (s2a, s2b, s5s8), and GGSN (if associated) statistics collected
 - SAEGW associated P-GW service statistics not collected
3. S-GW service node configuration will store the following statistics:
 - S-GW, eGTP-C ingress/egress, and GTP-U ingress/egress statistics collected
 - SAEGW associated S-GW service statistics not collected
4. GGSN statistics:
 - GGSN service statistics, if not associated with P-GW service, collected
5. Session disconnect reasons collected if GGSN/P-GW/SAEGW/S-GW is enabled

Error Handling

If adding new statistics is going to cause overflow of 1 MB buffer, that service and the corresponding node will not be included. Checkpointing of any further nodes will also be stopped. Error level log will be flagged if total memory requirement goes above 1 MB.

Limitations

- A backup interval must be specified and counters are backed up only at the specified interval. For example, if the backup interval is specified as 5 minutes, then counters are backed up every 5 minutes. Suppose backup happened at Nth minute and the configured backup interval is for every 5 minutes, then if a task crash happens at N+4 minutes, the GGSN, P-GW, SAEGW, and/or S-GW recovers only the values backed up at Nth minute and the data for the past 4 minutes is lost.
- Only statistics maintained at the SessMgr are backed up. Statistics at other managers are not backed up or recovered.
- The following statistics are not considered for backup:
 - APN-level statistics
 - eGTP-C APN-QCI statistics
 - DemuxMgr statistics
- The CLI command **clear statistics** will not trigger checkpoint to delete the node statistics on AAAMgr. New checkpoint after timer expiry will overwrite the statistics.
- Maximum of 1 MB of statistics will be stored on AAAMgr. Services after the maximum size limit are not backed up.
- Setting the backup interval to shorter periods of time causes higher system overhead for checkpointing. Alternately, setting the backup interval to longer periods of time results in lower system overhead for checkpointing but higher probability of hitting the 1 MB storage limit.
- If SessMgr restarts and AAAMgr restarts before SessMgr recovers statistics from AAAMgr, then backed up statistics are lost.
- This feature is not applicable for ICSR.

Configuring Backup Statistics Feature

For the Backup and Recovery of Key KPI Statistics feature to work, it must be enabled by configuring the backup of statistics for the GGSN, P-GW, SAEGW, and/or S-GW.

Configuration

The following CLI commands are used to manage the functionality for the backing up of the key KPI statistics feature.

Enabling

The following configures the backup of statistics for the GGSN, P-GW, SAEGW, and/or S-GW and enables the Backup and Recovery of Key KPI Statistics feature.

```
configure
  statistics-backup { ggsn | pgw | saegw | sgw }
  exit
```

Setting the Backup Interval

The following command configures the number of minutes (0 to 60) between each backup of the statistics. When the backup interval is not specified, a default value of 5 minutes is used as the backup interval

```
configure
  statistics-backup-interval minutes
exit
```



Important Setting the backup interval to shorter periods of time causes higher system overhead for checkpointing. Alternately, setting the backup interval to longer periods of time results in lower system overhead for checkpointing but higher probability of hitting the 1 MB storage limit.

Disabling

The following configures the GGSN, P-GW, SAEGW, and/or S-GW to disable the backing up of statistics for the GGSN, P-GW, SAEGW, and/or S-GW.

```
configure
  no statistics-backup { ggsn | pgw | saegw | sgw }
exit
```

Verifying the Backup Statistics Feature Configuration

Use either the **show configuration** command or the **show configuration verbose** command to display the feature configuration.

If the feature was enabled in the configuration, two lines similar to the following will appear in the output of a **show configuration [verbose]** command:

```
statistics-backup pgw
statistics-backup-interval 5
```

Notes:

- The interval displayed is 5 minutes. 5 is the default. If the **statistics-backup-interval** command is included in the configuration, then the 5 would be replaced by the configured interval number of minutes.
- If the command to disable the feature is entered, then no **statistics-backup** line is displayed in the output generated by a **show configuration [verbose]** command.



CHAPTER 8

Bearer Re-establishment

- [Feature Summary and Revision History](#), on page 277
- [Introduction to Bearer Re-establishment](#), on page 278
- [How it Works](#), on page 278
- [Enabling Modify Bearer Request Forward from S-GW to P-GW](#), on page 278
- [P-GW Invokes Local Policy with New Event Restore-Bearers](#), on page 279
- [Show Commands and Outputs](#), on page 280

Feature Summary and Revision History

Summary Data

Applicable Product(s) or Functional Area	<ul style="list-style-type: none"> • P-GW • SAEGW
Applicable Platform(s)	<ul style="list-style-type: none"> • ASR 5500 • VPC-DI • VPC-SI
Feature Default	Disabled - Configuration Required
Related Changes in This Release	Not applicable
Related Documentation	<ul style="list-style-type: none"> • <i>Command Line Interface Reference</i> • <i>P-GW Administration Guide</i> • <i>SAEGW Administration Guide</i>

Table 30: Revision History

Revision Details	Release
First introduced	21.19

Introduction to Bearer Re-establishment

A UE Relay Network comprises of multiple RAN and EPC nodes.

In some deployments, one MME can play the role of both User-UE MME and Relay-UE MME.

In a UE Relay network, System Architecture Evolution Gateways (SAEGWs) are deployed to play the role of combined 'Relay-UE's SGW/P-GW'. The SAEGWs are configured using only local-policy (that is no connection to PCRF).

As part of initial attach request from Relay Node UE, P-GW (in the aforementioned SAEGW) creates dedicated bearers (for example, QCI-1 for GBR and QCI5 for non-GBR) on top of the default bearer (for example, QCI6). This is done based on an appropriate local policy configuration which is described in later sections of this chapter.

When RF condition degrades, Relay Node UE loses the RRC connection to macro eNB. As a result, macro eNB initiates an S1 Release procedure with abnormal cause (for example, 'Radio Connection with UE lost' or 'unspecified'). For these type of causes MME typically preserves non-GBR bearer and deletes GBR bearers. As a result, GBR bearers (for example, QCI-1 bearer) is deleted by the MME.

After the RRC Connection is re-established, the Relay Node UE sends Service Request to the MME. The MME sends Initial Context Setup Request to macro eNB to set up the previously preserved non-GBR bearers. The MME does not re-establish the GBR bearer since it was not preserved. As a result, Relay Node UE does not have the GBR bearer until a full re-attach procedure occurs.

Since GBR bearer is not re-established, the GBR traffic is carried over the default non-GBR bearer and the voice performance is degraded.

Using this feature SAEGW is able to re-establish the previously deleted GBR bearer when MME sends the Modify Bearer Request to re-establish the preserved the non-GBR bearers.

How it Works

SAEGW re-establishes the previously deleted GBR bearer when MME sends the Modify Bearer Request, to re-establish the preserved non-GBR bearers.

This is achieved in SAEGW using two different mechanisms:

- Forwarding the Modify Bearer Request from SGW to P-GW
- P-GW to invoke local policy with a new event restore-bearers

Enabling Modify Bearer Request Forward from S-GW to P-GW

Use the following configuraion to enable forced forwarding of Modify Bearer Request from S-GW to P-GW:

```
configure
  context context_name
    sgw-service service_name
      enable-bearer-restore
    end
```

In S-GW service, whenever **enable-bearer-restore** option is set, modify bearer request is forwarded by S-GW to P-GW. It happens when the S-GW service is under SAEGW service.

For example:

```
config
 context ingress
  sgw-service sgw-service
  enable-bearer-restore
```



Note

- Without this CLI, S-GW only forwards the Modify Bearer Request message to P-GW if certain conditions are met. For example, RAT change, TimeZone change, ULI change, Handover indication flag, and so on as per 3GPP specifications.
- To avoid forwarding Modify Bearer Requests unnecessarily to P-GW, **enable-bearer-restore** should only be used when local policy is configured for **restore-bearer** event as described in next section.

P-GW Invokes Local Policy with New Event Restore-Bearers

A list of events supported under `eventbase` is enhanced with `restore-bearers`. This event is invoked when P-GW gets a Modify Bearer Request from S-GW. If local policy configuration has the **restore-bearer** event under `eventbase` then corresponding rules are applied.

Use the following configuration to re-establish missing bearers under local policy:

configure

```
local-policy-service local_policy_name
 eventbase eventbase_name
  [ no ] rule priority integer
  event restore-bearers ruledef ruledef_name actiondef actiondef_name
 end
```

Following is an example for local policy configuration:

```
local-policy-service local_policy
 ruledef apn_apn2
  condition priority 100 apn match apn2.com
 #exit

ruledef apn_apn1
  condition priority 100 apn match apn1.com
 #exit

ruledef ded_bearer_creation_fail
  condition priority 100 apn match apn2.com
  condition priority 200 cause-code match 72 73 90 100 110
 #exit

actiondef apn2_newcall
  action priority 100 allow-session
  action priority 500 activate-rule name apn2_dedicated_grp_of_rd
  action priority 600 activate-rule name apn2_qci1_dedicated_grp_of_rd
 #exit

actiondef apn2_restore_bearer_config
  action priority 100 allow-session
  action priority 500 activate-rule name apn2_dedicated_grp_of_rd
```

```

    action priority 600 activate-rule name apn2_qci1_dedicated_grp_of_rd
#exit

actiondef apn2_retry_dedicated_bearer
    action priority 500 activate-rule name apn2_dedicated_grp_of_rd
    action priority 600 activate-rule name apn2_qci1_dedicated_grp_of_rd
    action priority 700 retry-count 4
    action priority 2000 allow-session
#exit

actiondef apn1_newcall
    action priority 100 allow-session
#exit

eventbase default
    rule priority 100 event new-call ruledef apn_apn1 actiondef apn1_newcall
    rule priority 200 event new-call ruledef apn_apn2 actiondef apn2_newcall
    rule priority 400 event rule-report-status ruledef ded_bearer_creation_fail actiondef
apn2_retry_dedicated_bearer
    rule priority 600 event restore-bearers ruledef apn_apn2 actiondef
apn2_restore_bearer_config
#exit

```

The key point in the above configuration is that both "new-call" and "restore-bearers" events, the actiondefs comprise of same actions. As a result, any missing bearer (such as a QCI-1 GBR bearer) is established.

At the time of "new-call" event, both QCI-1 (GBR) and QCI-5 (non-GBR) bearers are created. At the time of "restore-bearer" event, local policy will return actions to create both QCI-1 and QCI-5 bearers but since QCI-5 bearer already exists (as it was preserved), only QCI-1 bearer is established.

Show Commands and Outputs

show saegw-service statistics all

The output of this command displays the number of times SGW forwards modify bearer request to PGW due to flag enable-bearer-restore:

The output of this command includes the following fields:

MBR:— Displays the Dynamic User Plane Selection Statistics:

- Attempted — Displays the number of modify bearer request attempts between S-GW and P-GW due to flag enable bearers restore.
- Successful— Displays the total number of succesful modify bearer request between S-GW and P-GW due to flag enable bearers restore.
- Failure — Displays the total number of failure modify bearer request between S-GW and P-GW due to flag enable bearers restore.
- Mismatch DNS response — Displays mismatch DNS repsonse between S-GW and P-GW due to flag enable bearers restore.
- Negative DNS response — Displays negative DNS repsonse between S-GW and P-GW due to flag enable bearers restore.
- DNS timed out —Displays DNS timed out between S-GW and P-GW due to flag enable bearers restore.

show local-policy statistics all

The output of this command displays the list of events under event-base local-policy when S-GW sends modify bearer request to P-GW.

The output of this command includes the following fields:

Restore Bearers — Displays the restore-bearer enable and disable in local policy configuration.



CHAPTER 9

Bulkstats for GTP-C Messages by ARP Value

This chapter describes StarOS support for the Bulkstats for GTP-C Messages by ARP Value feature on the P-GW, SAE-GW, and S-GW.

- [Feature Description, on page 283](#)
- [Performance Indicator Changes, on page 284](#)

Feature Description

To comply with the “Long Term Evolution (LTE) Access Network Government Industry Requirements (GIR) for National Security/Emergency Preparedness (NS/EP) Next Generation Network (NGN) Priority” to support emergency calls over Voice over LTE (VoLTE), several Key Performance Indicators (KPIs) have been introduced with this feature. This feature is utilized to collect statistics for total number of GTP-C messages received for Enhanced Multimedia Priority Service (eMPS) session for specified interval (in minutes). The list of GTP-C messages are defined in accordance with the GIR document. As part of this feature:

- The S-GW will generate peg counts of the total number of received GTP-C messages containing an Allocation and Retention Priority (ARP), chosen from the set of values allocated for NS/EP NGN-PS use, for a specified interval (in minutes). This peg count is administered at the S-GW level.
- The P-GW will generate peg counts of the total number of received GTP-C messages containing an ARP, chosen from the set of values allocated for NS/EP NGN-PS use, for a specified interval (in minutes). This peg count is administered at the specific P-GW level.
- The peg counts for GTP-C messages are broken down by message type similar to existing GTP-C message counters. The bulkstats are broken down by applicable S-GW and P-GW service and S5, S8, S11, and S4 interfaces.

Bulkstats are added for eMPS session/message.

Piggy-back Message

For piggy-back messages, if either of the messages have matching ARP or result into converting non-eMPS session to eMPS session, then both messages are counted as eMPS message and corresponding statistics for both messages are incremented.

If Modify Bearer Request is piggy-backed with Create Bearer Response on S11 interface of S-GW and Create Bearer Response result into converting non-eMPS session into eMPS session, then Modify Bearer Request statistics will not increment for this Modify Bearer Request.

Bulkstats Collection and Reset

Bulkstats are added under eGTP-C Schema and pgw-egtpc-s5s8 Schema. These eMPS bulkstats in eGTP-C Schema and pgw-egtpc-s5s8 Schema holds value only for a bulkstat interval, that is, value of these bulkstats shows number of eMPS messages exchanged during the bulkstat interval.

Limitations

This section identifies the known limitations of the feature:

- Peer level and APN level statistics are not collected.
- MPS statistics recovery is not supported.
- MPS statistics are not collected for CSReq, DDNReq, and change notification messages rejected by demux with ARP for eMPS sessions.
- MPS statistics are not collected for retried/re-transmitted messages.

Licensing



Important

Bulkstats for GTP-C Messages by ARP Value feature requires that a valid license key be installed. Contact your Cisco Account or Support representative for information on how to obtain a license.

Performance Indicator Changes

S-GW Ingress S4 Interface

The following CLI commands are modified to display the eMPS session related GTP-C message statistics for S4 interface of S-GW Ingress:

- **show egtpc statistics interface sgw-ingress interface-type s4**
 - **interface-type**: Displays interface level GTP-C message statistics
 - **s4**: Displays interface level GTP-C message statistics for S4 interface
- **show egtpc statistics egtp-service *sgw_egtpc_service_name* interface-type s4**
 - **s4**: Interface type S4 for S-GW eGTP-C interface

The output of the above CLI commands displays the following new parameters:

- **Total eMPS Statistics**: Cumulative GTP-C message statistics for messages received/transmitted on eMPS Sessions.
- **Current interval eMPS Statistics**: GTP-C message statistics for messages received/transmitted on eMPS Sessions for current statistics collection interval. Statistics collection interval will be same as

bulkstats collection interval. If bulk stats collection is not configured, then Current MPS Statistics will be same as Total MPS Statistics.

- **Create Session Request (Total RX):** This counter will be incremented by S-GW when it receives Create session request message on S4 interface containing an ARP value configured in MPS Profile.
- **Create Session Response (Total TX):** This counter will be incremented by S-GW when it transmits Create session response message on S4 interface containing an ARP value configured in MPS Profile.

S-GW Ingress S11 Interface

The following CLI commands are modified to display the eMPS session related GTP-C message statistics for S11 interface of S-GW Ingress:

- **show egtpc statistics interface sgw-ingress interface-type s11**
 - **interface-type:** Displays interface level GTP-C message statistics
 - **s11:** Displays interface level GTP-C message statistics for S11 interface
- **show egtpc statistics egtp-service *sgw_egtpc_service_name* interface-type s11**
 - **s11:** Interface type S11 for S-GW eGTP-C interface

The output of the above CLI commands displays the following new parameters:

- **Total eMPS Statistics:** Cumulative GTP-C message statistics for messages received/transmitted on eMPS Sessions.
- **Current interval eMPS Statistics:** GTP-C message statistics for messages received/transmitted on eMPS Sessions for current statistics collection interval. Statistics collection interval will be same as bulkstats collection interval. If bulk stats collection is not configured, then Current MPS Statistics will be same as Total MPS Statistics.
- **Create Session Request (Total RX):** This counter will be incremented by S-GW when it receives Create session request message on S11 interface containing an ARP value configured in MPS Profile.
- **Create Session Response (Total TX):** This counter will be incremented by S-GW when it transmits Create session response message on S11 interface containing an ARP value configured in MPS Profile.
- **Modify Bearer Request (Total RX):** This counter will be incremented by S-GW when it receives Modify Bearer request message on S11 interface containing an ARP value configured in MPS Profile.
- **Modify Bearer Response (Total TX):** This counter will be incremented by S-GW when it transmits Modify Bearer response message on S11 interface containing an ARP value configured in MPS Profile.
- **Create Bearer Request (Total TX):** This counter will be incremented by S-GW when it transmits Create Bearer request message on S11 interface containing an ARP value configured in MPS Profile.
- **Create Bearer Response (Total RX):** This counter will be incremented by S-GW when it receives Create Bearer response message on S11 interface containing an ARP value configured in MPS Profile.
- **Downlink Data Notification (Total TX):** This counter will be incremented by S-GW when it transmits Downlink Data Notification message on S11 interface containing an ARP value configured in MPS Profile.

- **Downlink Data Notification Ack (Total RX):** This counter will be incremented by S-GW when it receives Downlink Data Notification Ack message on S11 interface containing an ARP value configured in MPS Profile.
- **Update Bearer Request (Total TX):** This counter will be incremented by S-GW when it transmits Update Bearer request message on S11 interface containing an ARP value configured in MPS Profile.
- **Update Bearer Response (Total RX):** This counter will be incremented by S-GW when it receives Update Bearer response message on S11 interface containing an ARP value configured in MPS Profile.

S-GW Egress GTP-based S5/S8 Interface

The following CLI commands are modified to display the eMPS session related GTP-C message statistics for S5/S8 interface of S-GW Egress:

- **show egtpc statistics interface sgw-egress interface-type s5s8**
 - **interface-type:** Displays interface level GTP-C message statistics
 - **s5s8:** Displays interface level GTP-C message statistics for S5/S8 interface
- **show egtpc statistics egtp-service *sgw_egtpc_service_name* interface-type sgw-s5s8**
 - **sgw-s5s8:** Interface type S5/S8 for S-GW eGTP-C interface

The output of the above CLI commands displays the following new parameters:

- **Total eMPS Statistics:** Cumulative GTP-C message statistics for messages received/transmitted on eMPS Sessions.
- **Current interval eMPS Statistics:** GTP-C message statistics for messages received/transmitted on eMPS Sessions for current statistics collection interval. Statistics collection interval will be same as bulkstats collection interval. If bulk stats collection is not configured, then Current MPS Statistics will be same as Total MPS Statistics.
- **Create Session Request (Total TX):** This counter will be incremented by S-GW when it transmits Create session request message on S5/S8 interface containing an ARP value configured in MPS Profile.
- **Create Session Response (Total RX):** This counter will be incremented by S-GW when it receives Create session response message on S5/S8 interface containing an ARP value configured in MPS Profile.
- **Modify Bearer Request (Total TX):** This counter will be incremented by S-GW when it transmits Modify Bearer request message on S5/S8 interface containing an ARP value configured in MPS Profile.
- **Modify Bearer Response (Total RX):** This counter will be incremented by S-GW when it receives Modify Bearer response message on S5/S8 interface containing an ARP value configured in MPS Profile.
- **Create Bearer Request (Total RX):** This counter will be incremented by S-GW when it receives Create Bearer request message on S5/S8 interface containing an ARP value configured in MPS Profile.
- **Create Bearer Response (Total TX):** This counter will be incremented by S-GW when it transmits Create Bearer response message on S5/S8 interface containing an ARP value configured in MPS Profile.
- **Update Bearer Request (Total RX):** This counter will be incremented by S-GW when it receives Update Bearer request message on S5/S8 interface containing an ARP value configured in MPS Profile.

- **Update Bearer Response (Total TX):** This counter will be incremented by S-GW when it transmits Update Bearer response message on S5/S8 interface containing an ARP value configured in MPS Profile.

P-GW Ingress GTP-based S5/S8 Interface

The following CLI commands are modified to display the eMPS session related GTP-C message statistics for S5/S8 interface of P-GW Ingress:

- **show egtpc statistics interface pgw-ingress interface-type s5s8**
- **show egtpc statistics egtp-service *pgw_egtpc_service_name* interface-type s5s8**
 - **s5s8:** Interface type S5/S8 for P-GW eGTP-C interface.

The output of the above CLI commands displays the following new parameters:

- **Total eMPS Statistics:** Cumulative GTP-C message statistics for messages received/transmitted on eMPS Sessions.
- **Current interval eMPS Statistics:** GTP-C message statistics for messages received/transmitted on eMPS Sessions for current statistics collection interval. Statistics collection interval will be same as bulkstats collection interval. If bulk stats collection is not configured, then Current MPS Statistics will be same as Total MPS Statistics.
- **Create Session Request (Total RX):** This counter will be incremented by P-GW when it receives Create session request message on S5/S8 interface containing an ARP value configured in MPS Profile.
- **Create Session Response (Total TX):** This counter will be incremented by P-GW when it transmits Create session response message on S5/S8 interface containing an ARP value configured in MPS Profile.
- **Modify Bearer Request (Total RX):** This counter will be incremented by P-GW when it receives Modify Bearer request message on S5/S8 interface containing an ARP value configured in MPS Profile.
- **Modify Bearer Response (Total TX):** This counter will be incremented by P-GW when it transmits Modify Bearer response message on S5/S8 interface containing an ARP value configured in MPS Profile.
- **Create Bearer Request (Total TX):** This counter will be incremented by P-GW when it receives Create Bearer request message on S5/S8 interface containing an ARP value configured in MPS Profile.
- **Create Bearer Response (Total RX):** This counter will be incremented by P-GW when it receives Create Bearer response message on S5/S8 interface containing an ARP value configured in MPS Profile.
- **Update Bearer Request (Total TX):** This counter will be incremented by P-GW when it transmits Update Bearer request message on S5/S8 interface containing an ARP value configured in MPS Profile.
- **Update Bearer Response (Total RX):** This counter will be incremented by P-GW when it receives Update Bearer response message on S5/S8 interface containing an ARP value configured in MPS Profile.

clear egtpc

The following CLI commands are modified to clear eMPS statistics at interface level and eGTP-C service level:

- **clear egtpc statistics interface-type interface-pgw-ingress interface s5s8**: Clears interface statistics along with eMPS statistics for all eGTP-C services of P-GW Ingress type and S5/S8 interface.
- **clear egtpc statistics interface-type [interface-sgw-ingress | interface-sgw-egress] interface [s4 | s11 | sgw-s5s8]**: Clears interface statistics along with eMPS statistics for all eGTP-C services of S-GW Ingress type and S4 or S11 interface/S-GW Egress type and S5/S8 interface.
- **clear egtpc statistics egtp-service *pgw_egtpc_service_name* interface [s5s8]**: Clears interface statistics along with eMPS statistics for all P-GW eGTP-C services and S5/S8 interface.
- **clear egtpc statistics egtp-service *sgw_egtpc_service_name* interface [s11 | s4 | sgw-s5s8]**: Clears interface statistics along with eMPS statistics for all S-GW eGTP-C services and S4 or S11 or S5/S8 interface.

P-GW eGTP-C S5/S8 Schema

The following new bulk statistics variables are added to the P-GW eGTP-C S5/S8 schema in support of this feature:

- **tun-recv-createsreq-emps** – The total number of tunnel - create session request - messages received by the system for eMPS subscriber on interface s5s8. This stat is for current bulkstat interval only.
- **tun-sent-createsresp-emps** – The total number of tunnel - create session response - messages sent by the system for eMPS subscriber on interface s5s8. This stat is for current bulkstat interval only.
- **tun-recv-modbearerreq-emps** – The total number of tunnel - modify bearer request - messages received by the system for eMPS subscriber on interface s5s8. This stat is for current bulkstat interval only.
- **tun-sent-modbearerresp-emps** – The total number of tunnel - modify bearer response - messages sent by the system for eMPS subscriber on interface s5s8. This stat is for current bulkstat interval only.
- **tun-sent-crebearerreq-emps** – The total number of tunnel - create bearer request - messages sent by the system for eMPS subscriber on interface s5s8. This stat is for current bulkstat interval only.
- **tun-recv-crebearerresp-emps** – The total number of tunnel - create bearer response - messages received by the system for eMPS subscriber on interface s5s8. This stat is for current bulkstat interval only.
- **tun-sent-updbearerreq-emps** – The total number of tunnel - update bearer request - messages sent by the system for eMPS subscriber on interface s5s8. This stat is for current bulkstat interval only.
- **tun-recv-updbearerresp-emps** – The total number of tunnel - update bearer response - messages received by the system for eMPS subscriber on interface s5s8. This stat is for current bulkstat interval only.

eGTP-C Schema

The following new bulk statistics variables are added to the eGTP-C schema in support of this feature:

- **s11-tun-recv-createsreq-emps** – The total number of tunnel - create session request - messages received by the system for eMPS subscriber on interface s11. This stat is for current bulkstat interval only.
- **s11-tun-sent-createsresp-emps** – The total number of tunnel - create session response - messages sent by the system for eMPS subscriber on interface s11. This stat is for current bulkstat interval only.

- s11-tun-recv-modbearerreq-emps – The total number of tunnel - modify bearer request - messages received by the system for eMPS subscriber on interface s11. This stat is for current bulkstat interval only.
- s11-tun-sent-modbearerresp-emps – The total number of tunnel - modify bearer response - messages sent by the system for eMPS subscriber on interface s11. This stat is for current bulkstat interval only.
- s11-tun-sent-crebearerreq-emps – The total number of tunnel - create bearer request - messages sent by the system for eMPS subscriber on interface s11. This stat is for current bulkstat interval only.
- s11-tun-recv-crebearerresp-emps – The total number of tunnel - create bearer response - messages received by the system for eMPS subscriber on interface s11. This stat is for current bulkstat interval only.
- s11-tun-sent-updbearerreq-emps – The total number of tunnel - update bearer request - messages sent by the system for eMPS subscriber on interface s11. This stat is for current bulkstat interval only.
- s11-tun-recv-updbearerresp-emps – The total number of tunnel - update bearer response - messages received by the system for eMPS subscriber on interface s11. This stat is for current bulkstat interval only.
- s11-tun-sent-ddnreq-emps – The total number of downlink data notification - messages sent by the system for eMPS subscriber on interface s11. This stat is for current bulkstat interval only.
- s11-tun-recv-ddnack-emps – The total number of downlink data notificatino acknowledge - messages received by the system for eMPS subscriber on interface s11. This stat is for current bulkstat interval only.
- s4-tun-recv-createsessreq-emps – The total number of tunnel - create session request - messages received by the system for eMPS subscriber on interface s4. This stat is for current bulkstat interval only.
- s4-tun-sent-createsessresp-emps – The total number of tunnel - create session response - messages sent by the system for eMPS subscriber on interface s4. This stat is for current bulkstat interval only.
- tun-sent-createsessreq-emps – The total number of tunnel - create session request - messages sent by the system for eMPS subscriber on interface s5s8. This stat is for current bulkstat interval only.
- tun-recv-createsessresp-emps – The total number of tunnel - create session response - messages received by the system for eMPS subscriber on interface s5s8. This stat is for current bulkstat interval only.
- tun-sent-modbearerreq-emps – The total number of tunnel - modify bearer request - messages sent by the system for eMPS subscriber on interface s5s8. This stat is for current bulkstat interval only.
- tun-recv-modbearerresp-emps – The total number of tunnel - modify bearer response - messages received by the system for eMPS subscriber on interface s5s8. This stat is for current bulkstat interval only.
- tun-recv-crebearerreq-emps – The total number of tunnel - create bearer request - messages received by the system for eMPS subscriber on interface s5s8. This stat is for current bulkstat interval only.
- tun-sent-crebearerresp-emps – The total number of tunnel - create bearer response - messages sent by the system for eMPS subscriber on interface s5s8. This stat is for current bulkstat interval only.
- tun-recv-updbearerreq-emps – The total number of tunnel - update bearer request - messages received by the system for eMPS subscriber on interface s5s8. This stat is for current bulkstat interval only.
- tun-sent-updbearerresp-emps – The total number of tunnel - update bearer response - messages sent by the system for eMPS subscriber on interface s5s8. This stat is for current bulkstat interval only.



CHAPTER 10

CoA, RADIUS DM, and Session Redirection (Hotlining)

This chapter describes Change of Authorization (CoA), Disconnect Message (DM), and Session Redirect (Hotlining) support in the system. RADIUS attributes, Access Control Lists (ACLs) and filters that are used to implement these features are discussed. The product administration guides provide examples and procedures for configuration of basic services on the system. It is recommended that you select the configuration example that best meets your service model, and configure the required elements for that model, as described in this Administration Guide, before using the procedures in this chapter.



Important Not all functions, commands, and keywords/variables are available or supported for all network function or services. This depends on the platform type and the installed license(s).

- [RADIUS Change of Authorization and Disconnect Message, on page 291](#)
- [Session Redirection \(Hotlining\), on page 296](#)

RADIUS Change of Authorization and Disconnect Message

This section describes how the system implements CoA and DM RADIUS messages and how to configure the system to use and respond to CoA and DM messages.

CoA Overview

The system supports CoA messages from the AAA server to change data filters associated with a subscriber session. The CoA request message from the AAA server must contain attributes to identify NAS and the subscriber session and a data filter ID for the data filter to apply to the subscriber session. The filter-id attribute (attribute ID 11) contains the name of an Access Control List (ACL). For detailed information on configuring ACLs, refer to the *IP Access Control Lists* chapter in the *System Administration Guide*.

If the system successfully executes a CoA request, a CoA-ACK message is sent back to the RADIUS server and the data filter is applied to the subscriber session. Otherwise, a CoA-NAK message is sent with an error-cause attribute without making any changes to the subscriber session.



Important Changing ACL and rulebase together in a single CoA is not supported. For this, two separate CoA requests can be sent through AAA server requesting for one attribute change per request.

DM Overview

The DM message is used to disconnect subscriber sessions in the system from a RADIUS server. The DM request message should contain necessary attributes to identify the subscriber session. If the system successfully disconnects the subscriber session, a DM-ACK message is sent back to the RADIUS server, otherwise, a DM-NAK message is sent with proper error reasons.

License Requirements

The RADIUS Change of Authorization (CoA) and Disconnect Message (DM) are licensed Cisco features. A separate feature license may be required. Contact your Cisco account representative for detailed information on specific licensing requirements. For information on installing and verifying licenses, refer to the *Managing License Keys* section of the *Software Management Operations* chapter in the *System Administration Guide*.

Enabling CoA and DM

To enable RADIUS Change of Authorization and Disconnect Message:

-
- Step 1** Enable the system to listen for and respond to CoA and DM messages from the RADIUS server as described in [Enabling CoA and DM, on page 292](#).
 - Step 2** Save your configuration to flash memory, an external memory device, and/or a network location using the Exec mode command **save configuration**. For additional information on how to verify and save configuration files, refer to the *System Administration Guide* and the *Command Line Interface Reference*.
 - Step 3** View CoA and DM message statistics as described in [Viewing CoA and DM Statistics, on page 294](#).

Important Commands used in the configuration examples in this section provide base functionality to the extent that the most common or likely commands and/or keyword options are presented. In many cases, other optional commands and/or keyword options are available. Refer to the *Command Line Interface Reference* for complete information regarding all commands. Not all commands and keywords/variables are available or supported. This depends on the platform type and the installed license(s).

Enabling CoA and DM

Use the following example to enable the system to listen for and respond to CoA and DM messages from the RADIUS server:

```
configure
context <context_name>
radius change-authorize-nas-ip <ipv4/ipv6_address>
end
```

Notes:

- `<context_name>` must be the name of the AAA context where you want to enable CoA and DM.
For more information, refer to the *AAA Interface Administration and Reference*.
- A number of optional keywords and variables are available for the **radius change-authorize-nas-ip** command. For more information regarding this command please refer to the *Command Line Interface Reference*.

CoA and DM Attributes

For CoA and DM messages to be accepted and acted upon, the system and subscriber session to be affected must be identified correctly.

To identify the system, use any one of the following attributes:

- **NAS-IP-Address**: NAS IP address if present in the CoA/DM request should match with the NAS IP address.
- **NAS-Identifier**: If this attribute is present, its value should match to the nas-identifier generated for the subscriber session

To identify the subscriber session, use any one of the following attributes.

- If 3GPP2 service is configured the following attribute is used for correlation identifier:
 - **3GPP2-Correlation-ID**: The values should exactly match the 3GPP2-correlation-id of the subscriber session. This is one of the preferred methods of subscriber session identification.
- If 3GPP service is configured the following attributes are used for different identifiers:
 - **3GPP-IMSI**: International Mobile Subscriber Identification (IMSI) number should be validated and matched with the specified IMSI for specific PDP context.
 - **3GPP-NSAPI**: Network Service Access Point Identifier (NSAPI) should match to the NSAPI specified for specific PDP context.
- **User-Name**: The value should exactly match the subscriber name of the session. This is one of the preferred methods of subscriber session identification.
- **Framed-IP-Address**: The values should exactly match the framed IP address of the session.
- **Calling-station-id**: The value should match the Mobile Station ID.

To specify the ACL to apply to the subscriber session, use the following attribute:

- **Filter-ID**: CoA only. This must be the name of an existing Access Control List. If this is present in a CoA request, the specified ACL is immediately applied to the specified subscriber session. The Context Configuration mode command, **radius attribute filter-id direction**, controls in which direction filters are applied.

The following attributes are also supported:

- **Event-Timestamp**: This attribute is a timestamp of when the event being logged occurred.
- If 3GPP2 service is configured following additional attributes are supported:

- 3GPP2-Disconnect-Reason: This attribute indicates the reason for disconnecting the user. This attribute may be present in the RADIUS Disconnect-request Message from the Home Radius server to the PDSN.
- 3GPP2-Session-Termination-Capability: When CoA and DM are enabled by issuing the radius change-authorize-nas-ip command, this attribute is included in a RADIUS Access-request message to the Home RADIUS server and contains the value 3 to indicate that the system supports both Dynamic authorization with RADIUS and Registration Revocation for Mobile IPv4. The attribute is also included in the RADIUS Access-Accept message and contains the preferred resource management mechanism by the home network, which is used for the session and may include values 1 through 3.

CoA and DM Error-Cause Attribute

The Error-Cause attribute is used to convey the results of requests to the system. This attribute is present when a CoA or DM NAK or ACK message is sent back to the RADIUS server.

The value classes of error causes are as follows:

- 0-199, 300-399 reserved
- 200-299 - successful completion
- 400-499 - errors in RADIUS server
- 500-599 - errors in NAS/Proxy

The following error cause is sent in ACK messages upon successful completion of a CoA or DM request:

- 201- Residual Session Context Removed

The following error causes are sent in NAK messages when a CoA or DM request fails:

- 401 - Unsupported Attribute
- 402 - Missing Attribute
- 403 - NAS Identification Mismatch
- 404 - Invalid Request
- 405 - Unsupported Service
- 406 - Unsupported Extension
- 501 - Administratively Prohibited
- 503 - Session Context Not Found
- 504 - Session Context Not Removable
- 506 - Resources Unavailable

Viewing CoA and DM Statistics

View CoA and DM message statistics by entering the following command:

```
show session subsystem facility aaamgr
```

The following is a sample output of this command.

```

1 AAA Managers
807 Total aaa requests                0 Current aaa requests
379 Total aaa auth requests           0 Current aaa auth requests
    0 Total aaa auth probes            0 Current aaa auth probes
    0 Total aaa auth keepalive         0 Current aaa auth keepalive
426 Total aaa acct requests           0 Current aaa acct requests
    0 Total aaa acct keepalive         0 Current aaa acct keepalive
379 Total aaa auth success            0 Total aaa auth failure
    0 Total aaa auth purged           0 Total aaa auth cancelled
    0 Total auth keepalive success     0 Total auth keepalive failure
    0 Total auth keepalive purged
    0 Total aaa auth DMU challenged
367 Total radius auth requests        0 Current radius auth requests
    2 Total radius auth requests retried
    0 Total radius auth responses dropped
    0 Total local auth requests        0 Current local auth requests
12 Total pseudo auth requests         0 Current pseudo auth requests
    0 Total null-username auth requests (rejected)
    0 Total aaa acct completed         0 Total aaa acct purged
    0 Total acct keepalive success     0 Total acct keepalive timeout
    0 Total acct keepalive purged
    0 Total aaa acct cancelled
426 Total radius acct requests        0 Current radius acct requests
    0 Total radius acct requests retried
    0 Total radius acct responses dropped
    0 Total gtpv acct requests         0 Current gtpv acct requests
    0 Total gtpv acct cancelled        0 Total gtpv acct purged
    0 Total null acct requests         0 Current null acct requests
54 Total aaa acct sessions            5 Current aaa acct sessions
    3 Total aaa acct archived          0 Current aaa acct archived
    0 Current recovery archives        0 Current valid recovery records

    2 Total aaa sockets opened         2 Current aaa sockets open
    0 Total aaa requests pend socket open
    0 Current aaa requests pend socket open
    0 Total radius requests pend server max-outstanding
    0 Current radius requests pend server max-outstanding
    0 Total aaa radius coa requests     0 Total aaa radius dm requests
    0 Total aaa radius coa acks        0 Total aaa radius dm acks
    0 Total aaa radius coa naks        0 Total aaa radius dm naks
    2 Total radius charg auth          0 Current radius charg auth
    0 Total radius charg auth succ     0 Total radius charg auth fail
    0 Total radius charg auth purg     0 Total radius charg auth cancel

    0 Total radius charg acct          0 Current radius charg acct
    0 Total radius charg acct succ     0 Total radius charg acct purg
    0 Total radius charg acct cancel
357 Total gtpv charg                  0 Current gtpv charg
357 Total gtpv charg success           0 Total gtpv charg failure
    0 Total gtpv charg cancel          0 Total gtpv charg purg
    0 Total prepaid online requests    0 Current prepaid online requests

    0 Total prepaid online success      0 Current prepaid online failure

    0 Total prepaid online retried      0 Total prepaid online cancelled

    0 Current prepaid online purged
    0 Total aaamgr purged requests
    0 SGSN: Total db records
    0 SGSN: Total sub db records
    0 SGSN: Total mm records

```

```
0 SGSN: Total pdp records
0 SGSN: Total auth records
```

Session Redirection (Hotlining)



Important Functionality described for this feature in this segment is not applicable for HNB-GW sessions.

Overview

Session redirection provides a means to redirect subscriber traffic to an external server by applying ACL rules to the traffic of an existing or a new subscriber session. The destination address and optionally the destination port of TCP/IP or UDP/IP packets from the subscriber are rewritten so the packet is forwarded to the designated redirected address. Return traffic to the subscriber has the source address and port rewritten to the original values. The redirect ACL may be applied dynamically by means of the RADIUS Change of Authorization (CoA) feature.

Note that the session redirection feature is only intended to redirect a very small subset of subscribers at any given time. The data structures allocated for this feature are kept to the minimum to avoid large memory overhead in the session managers.

License Requirements

The Session Redirection (Hotlining) is a licensed Cisco feature. A separate feature license may be required. Contact your Cisco account representative for detailed information on specific licensing requirements. For information on installing and verifying licenses, refer to the *Managing License Keys* section of the *Software Management Operations* chapter in the *System Administration Guide*.

Operation

ACL Rule

An ACL rule named **readdress server** supports redirection of subscriber sessions. The ACL containing this rule must be configured in the destination context of the user. Only TCP and UDP protocol packets are supported. The ACL rule allows specifying the redirected address and an optional port. The source and destination address and ports (with respect to the traffic originating from the subscriber) may be wildcarded. If the redirected port is not specified, the traffic will be redirected to the same port as the original destination port in the datagrams. For detailed information on configuring ACLs, refer to the *IP Access Control Lists* chapter in the *System Administration Guide*. For more information on **readdress server**, refer to the *ACL Configuration Mode Commands* chapter of the *Command Line Interface Reference*.

Redirecting Subscriber Sessions

An ACL with the **readdress server** rule is applied to an existing subscriber session through CoA messages from the RADIUS server. The CoA message contains the 3GPP2-Correlation-ID, User-Name, Acct-Session-ID, or Framed-IP-Address attributes to identify the subscriber session. The CoA message also contains the Filter-Id attribute which specifies the name of the ACL with the **readdress server** rule. This enables applying the ACL

dynamically to existing subscriber sessions. By default, the ACL is applied as both the input and output filter for the matching subscriber unless the Filter-Id in the CoA message bears the prefix **in:** or **out:**.

For information on CoA messages and how they are implemented in the system, refer to [RADIUS Change of Authorization and Disconnect Message, on page 291](#).



Important Changing ACL and rulebase together in a single CoA is not supported. For this, two separate CoA requests can be sent through AAA server requesting for one attribute change per request.

Session Limits On Redirection

To limit the amount of memory consumed by a session manager a limit of 2000 redirected session entries per session manager is allocated. This limit is equally shared by the set of subscribers who are currently being redirected. Whenever a redirected session entry is subject to revocation from a subscriber due to an insufficient number of available session entries, the least recently used entry is revoked.

Stopping Redirection

The redirected session entries for a subscriber remain active until a CoA message issued from the RADIUS server specifies a filter that does not contain the readdress server ACL rule. When this happens, the redirected session entries for the subscriber are deleted.

All redirected session entries are also deleted when the subscriber disconnects.

Handling IP Fragments

Since TCP/UDP port numbers are part of the redirection mechanism, fragmented IP datagrams must be reassembled before being redirected. Reassembly is particularly necessary when fragments are sent out of order. The session manager performs reassembly of datagrams and reassembly is attempted only when a datagram matches the redirect server ACL rule. To limit memory usage, only up to 10 different datagrams may be concurrently reassembled for a subscriber. Any additional requests cause the oldest datagram being reassembled to be discarded. The reassembly timeout is set to 2 seconds. In addition, the limit on the total number of fragments being reassembled by a session manager is set to 1000. If this limit is reached, the oldest datagram being reassembled in the session manager and its fragment list are discarded. These limits are not configurable.

Recovery

When a session manager dies, the ACL rules are recovered. The session redirect entries have to be re-created when the MN initiates new traffic for the session. Therefore when a crash occurs, traffic from the Internet side is not redirected to the MN.

AAA Accounting

Where destination-based accounting is implemented, traffic from the subscriber is accounted for using the original destination address and not the redirected address.

Viewing the Redirected Session Entries for a Subscriber

View the redirected session entries for a subscriber by entering the following command:

Viewing the Redirected Session Entries for a Subscriber

```
show subscribers debug-info { callid <id> | msid <id> | username <name> }
```

The following command displays debug information for a subscriber with the MSID 0000012345:

```
show subscribers debug-info msid 0000012345
```

The following is a sample output of this command:

```
username: user1 callid: 01callb1    msid: 0000100003
Card/Cpu: 4/2
Sessmgr Instance: 7
Primary callline:
Redundancy Status: Original Session
Checkpoints  Attempts  Success  Last-Attempt  Last-Success
  Full:      27      26      15700ms     15700ms
  Micro:    76      76      4200ms      4200ms
Current state: SMGR_STATE_CONNECTED
FSM Event trace:
      State                               Event
SMGR_STATE_OPEN                          SMGR_EVT_NEWCALL
SMGR_STATE_NEWCALL_ARRIVED                SMGR_EVT_ANSWER_CALL
SMGR_STATE_NEWCALL_ANSWERED               SMGR_EVT_LINE_CONNECTED
SMGR_STATE_LINE_CONNECTED                 SMGR_EVT_LINK_CONTROL_UP
SMGR_STATE_LINE_CONNECTED                 SMGR_EVT_AUTH_REQ
SMGR_STATE_LINE_CONNECTED                 SMGR_EVT_IPADDR_ALLOC_SUCCESS
SMGR_STATE_LINE_CONNECTED                 SMGR_EVT_AUTH_SUCCESS
SMGR_STATE_LINE_CONNECTED                 SMGR_EVT_UPDATE_SESS_CONFIG
SMGR_STATE_LINE_CONNECTED                 SMGR_EVT_LOWER_LAYER_UP

Data Reorder statistics
  Total timer expiry:      0      Total flush (tmr expiry): 0
  Total no buffers:      0      Total flush (no buffers): 0
  Total flush (queue full): 0      Total flush (out of range):0
  Total flush (svc change): 0      Total out-of-seq pkt drop: 0
  Total out-of-seq arrived: 0

IPv4 Reassembly Statistics:
  Success:      0      In Progress:      0
  Failure (timeout): 0      Failure (no buffers): 0
  Failure (other reasons): 0

Redirected Session Entries:
  Allowed:      2000      Current:      0
  Added:      0      Deleted:      0
  Revoked for use by different subscriber: 0

Peer callline:
Redundancy Status: Original Session
Checkpoints  Attempts  Success  Last-Attempt  Last-Success
  Full:      0      0      0ms          0ms
  Micro:    0      0      0ms          0ms
Current state: SMGR_STATE_CONNECTED
FSM Event trace:
      State                               Event
SMGR_STATE_OPEN                          SMGR_EVT_MAKECALL
SMGR_STATE_MAKECALL_PENDING               SMGR_EVT_LINE_CONNECTED
SMGR_STATE_LINE_CONNECTED                 SMGR_EVT_LOWER_LAYER_UP
SMGR_STATE_CONNECTED                     SMGR_EVT_AUTH_REQ
SMGR_STATE_CONNECTED                     SMGR_EVT_AUTH_SUCCESS
SMGR_STATE_CONNECTED                     SMGR_EVT_REQ_SUB_SESSION
SMGR_STATE_CONNECTED                     SMGR_EVT_RSP_SUB_SESSION

username: user1 callid: 01callb1    msid: 0000100003
Card/Cpu: 4/2
Sessmgr Instance: 7
Primary callline:
Redundancy Status: Original Session
Checkpoints  Attempts  Success  Last-Attempt  Last-Success
  Full:      27      26      15700ms     15700ms
  Micro:    76      76      4200ms      4200ms
```

```

Current state: SMGR_STATE_CONNECTED
FSM Event trace:
    State                               Event
    SMGR_STATE_OPEN                     SMGR_EVT_NEWCALL
    SMGR_STATE_NEWCALL_ARRIVED           SMGR_EVT_ANSWER_CALL
    SMGR_STATE_NEWCALL_ANSWERED          SMGR_EVT_LINE_CONNECTED
    SMGR_STATE_LINE_CONNECTED             SMGR_EVT_LINK_CONTROL_UP
    SMGR_STATE_LINE_CONNECTED             SMGR_EVT_AUTH_REQ
    SMGR_STATE_LINE_CONNECTED             SMGR_EVT_IPADDR_ALLOC_SUCCESS
    SMGR_STATE_LINE_CONNECTED             SMGR_EVT_AUTH_SUCCESS
    SMGR_STATE_LINE_CONNECTED             SMGR_EVT_UPDATE_SESS_CONFIG
    SMGR_STATE_LINE_CONNECTED             SMGR_EVT_LOWER_LAYER_UP
Data Reorder statistics
    Total timer expiry: 0                Total flush (tmr expiry): 0
    Total no buffers: 0                  Total flush (no buffers): 0
    Total flush (queue full): 0          Total flush (out of range): 0
    Total flush (svc change): 0          Total out-of-seq pkt drop: 0
    Total out-of-seq arrived: 0
IPv4 Reassembly Statistics:
    Success: 0                          In Progress: 0
    Failure (timeout): 0                 Failure (no buffers): 0
    Failure (other reasons): 0
Redirected Session Entries:
    Allowed: 2000                        Current: 0
    Added: 0                             Deleted: 0
    Revoked for use by different subscriber: 0
Peer callline:
Redundancy Status: Original Session
Checkpoints  Attempts  Success  Last-Attempt  Last-Success
Full:        0         0        0ms           0ms
Micro:       0         0        0ms           0ms
Current state: SMGR_STATE_CONNECTED
FSM Event trace:
    State                               Event
    SMGR_STATE_OPEN                     SMGR_EVT_MAKECALL
    SMGR_STATE_MAKECALL_PENDING          SMGR_EVT_LINE_CONNECTED
    SMGR_STATE_LINE_CONNECTED             SMGR_EVT_LOWER_LAYER_UP
    SMGR_STATE_CONNECTED                 SMGR_EVT_AUTH_REQ
    SMGR_STATE_CONNECTED                 SMGR_EVT_AUTH_SUCCESS
    SMGR_STATE_CONNECTED                 SMGR_EVT_REQ_SUB_SESSION
    SMGR_STATE_CONNECTED                 SMGR_EVT_RSP_SUB_SESSION
    SMGR_STATE_CONNECTED                 SMGR_EVT_ADD_SUB_SESSION
    SMGR_STATE_CONNECTED                 SMGR_EVT_AUTH_REQ
    SMGR_STATE_CONNECTED                 SMGR_EVT_AUTH_SUCCESS
Data Reorder statistics
    Total timer expiry: 0                Total flush (tmr expiry): 0
    Total no buffers: 0                  Total flush (no buffers): 0
    Total flush (queue full): 0          Total flush (out of range): 0
    Total flush (svc change): 0          Total out-of-seq pkt drop: 0
    Total out-of-seq arrived: 0
IPv4 Reassembly Statistics:
    Success: 0                          In Progress: 0
    Failure (timeout): 0                 Failure (no buffers): 0
    Failure (other reasons): 0
Redirected Session Entries:
    Allowed: 2000                        Current: 0
    Added: 0                             Deleted: 0
    Revoked for use by different subscriber: 0

```



CHAPTER 11

Collision Handling on the P-GW/SAEGW/S-GW

- [Feature Description, on page 301](#)
- [How It Works, on page 301](#)
- [Configuring Collision Handling, on page 304](#)
- [Monitoring the Collision Handling Feature, on page 305](#)

Feature Description

GTPv2 message collisions occur in the network when a node is expecting a particular procedure message from a peer node but instead receives a different procedure message from the peer. GTP procedure collisions are quite common in the network; especially with dynamic Policy and Charging Control, the chances of collisions happening in the network are very high.

These collisions are tracked by statistics and processed based on a pre-defined action for each message collision type. These statistics assist operators in debugging network issues.



Important If the SAEGW is configured as a pure P-GW or a pure S-GW, operators will see the respective collision statistics if they occur.

Relationships to Other Features

- This feature is a part of the base software license for the P-GW/SAEGW/S-GW. No additional license is required.
- A P-GW, S-GW, or SAEGW service must be configured to view GTPv2 collision statistics.

How It Works

Collision Handling

As GTPv2 message collisions occur, they are processed by the P-GW, SAEGW, and S-GW. They are also tracked by statistics and with information on how the collision was handled.

Specifically, the output of the **show egtpc statistics** verbose command has been enhanced to provide information on GTPv2 message collision tracking and handling at the S-GW and P-GW ingress interfaces, The information available includes:

- **Interface:** The interface on which the collision occurred: SGW (S4/S11), SGW (S5) and P-GW (S8).
- **Old Proc (Msg Type):** Indicates the ongoing procedure at eGTP-C when a new message arrived at the interface which caused the collision. The Msg Type in brackets specifies which message triggered this ongoing procedure. Note that the Old Proc are per 3GPP TS 23.401.
- **New Proc (Msg Type):** The new procedure and message type. Note that the New Proc are per 3GPP TS 23.401.
- **Action:** The pre-defined action taken to handle the collision. The action can be one of:
 - **No Collision Detected**
 - **Suspend Old:** Suspend processing of the original (old) message, process the new message, then resume old message handling.
 - **Abort Old:** Abort the original message handling and processes the new message.
 - **Reject New:** Reject the new message, and process the original (old) message.
 - **Silent Drop New:** Drop the new incoming message, and the process the old message.
 - **Parallel Hndl:** Handle both the original (old) and new messages in parallel.
 - **Buffer New:** Buffer the new message and process it once the original (old) message has been processed.
 - **Counter:** The number of times each collision type has occurred.



Important The *Message Collision Statistics* section of the command output appears only if any of the collision statistics have a counter total that is greater than zero.

Sample output:

```
Message Collision Statistics
Interface      Old Proc (Msg Type)      New Proc (Msg Type)      Action      Counter
SGW(S5)       NW Init Bearer Create (95)  NW Init PDN Delete (99)  Abort Old   1
```

In this instance, the output states that at the S-GW egress interface (S5) a Bearer creation procedure is going on due to a CREATE BEARER REQUEST(95) message from the P-GW. Before its response comes to the S-GW from the MME, a new procedure PDN Delete is triggered due to a DELETE BEARER REQUEST(99) message from the P-GW.

The action that is carried out due to this collision at the eGTP-C layer is to abort (Abort Old) the Bearer Creation procedure and carry on normally with the Initiate PDN Delete procedure. The Counter total of 1 indicates that this collision happened once.

Example Collision Handling Scenarios

This section describes several collision handling scenarios for the S-GW and P-GW.

The S-GW processes additional collisions at the S-GW ingress interface for:

1. Create Bearer Request or Update Bearer Request messages with Inter-MME/Inter-RAT Modify Bearer Request messages (with and without a ULI change).
2. Downlink Data Notification (DDN) message with Create Bearer Request or Update Bearer Request.

The S-GW behavior to handle these collision scenarios are as follows:

1. A CBRReq and MBReq [(Inter MME/Inter RAT (with or without ULI change))] collision at the S-GW ingress interface results in the messages being handled in parallel. The CBRReq will wait for a Create Bearer Response (CBRsp) from the peer. Additionally, an MBReq is sent in parallel to the P-GW.
2. An UBReq and MBReq [(Inter MME/Inter RAT (with or without a ULI change))] collision at the SGW ingress interface is handled with a suspend and resume procedure. The UBReq would be suspended and the MBReq would be processed. Once the MBRsp is sent to the peer from the SGW ingress interface, the UBReq procedure is resumed.
3. Create Bearer Request (CBR) or Update Bearer Request (UBR) with Downlink Data Notification (DDN) messages are handled parallel.

As a result, no S-GW initiated Cause Code message 110 (Temporarily rejected due to handover procedure in progress) will be seen as a part of such collisions. Collisions will be handled in parallel.

The following GTP-C example collision handling scenarios may also be seen on the P-GW:

DBCcmd/MBreq Collision Handling:

The P-GW enables operators to configure the behavior of the P-GW for collision handling of the Delete Bearer command (DBCcmd) message when the Modify Bearer Request (MBreq) message for the default bearer is pending at the P-GW.

There are three CLI-controlled options to handle the collision between the DBCcmd and MBReq messages:

- Queue the DBCcmd message when the MBreq message is pending. The advantage of this option is that the DBCcmd message is not lost for most of the collisions. It will remain on the P-GW until the MBRsp is sent out.
- Drop the DBCcmd message when the MBreq message is pending. Note that with this option the S-GW must retry the DBCcmd.
- Use pre-StarOS 19.0 behavior: abort the MBreq message and handle the DBCcmd message. The advantage of this option is that it provides backward compatibility if the operator wants to retain pre-StarOS 19.0 functionality.

The CLI command **collision handling** provides more flexibility in configuring the handling of the DBCcmd message and MBReq message collision scenario. Also refer to [Configuring DBCcmd Message Behavior, on page 304](#) in this document for instructions on how to configure the behavior for this collision handling scenario.

MBReq/CBreq Parallel Processing; Handling CBRsp:

The P-GW/S-GW handles the following example collision scenario:

The node queues the CBRsp message and feeds the CBRsp message to the P-GW/S-GW session manager when the MBRsp is sent out. As a result, operators will see no retransmission of CBRsp messages from the MME.

Handling UBrsps when Transaction is Suspended:

The P-GW/S-GW handles the following example collision scenario:

When the P-GW/S-GW receives an UBrsps message, then the P-GW/S-GW handles the UBrsps message for the suspended transaction. As a result, The UBrsps message will be buffered until the MBRsp message is sent out.

Collision Handling of MBR over MBR for Drop and Retry

To avoid collision over Modify bearer request (mbreq) message over mbreq, the MME supports collision of MBR over MBR Drop and Retry functionality through a `mbreq-over-mbreq drop` CLI configuration under the `egtp-service`. The following functions occur:

- MME sends modify bearer request when service request modify bearer request is in pending state
- S-GW drops the E-RAB procedure modify bearer request message
- MME retries the dropped MBR until first MBR response.

Limitations

There are no known limitations to the collision handling feature on the P-GW/SAEGW/S-GW.

Standards Compliance

Specifications and standards do not specify any hard rules for collision handling cases.

Configuring Collision Handling

Operators can use the Command Line Interface (CLI) to configure the behavior of the P-GW for handling the following GTPv2 message collision:

- DBcmd Message when the MBreq Message for the Default Bearer is pending at the P-GW



Important Configuration via the CLI is **not** required for all other P-GW and S-GW collision handling scenarios.

Configuring DBcmd Message Behavior

Use the following example to configure the collision handling behavior for the Delete Bearer command message when the Modify Bearer Request message for the Default Bearer is pending at the P-GW.

```
configure
  context context_name
    egtp-service egtp_service_name
      collision-handling dbcmd-over-mbreq { drop | queue }
      { default | no } collision-handling dbcmd-over-mbreq
    end
```

NOTES:

- **collision-handling dbcmd-over-mbreq** : Configures collision handling of DBcmd when MBreq is pending.
- **drop**: Drop the DBcmd message when the MBreq message is pending.
- **queue**: Queue the DBcmd message when the MBreq is message is pending.

The default behavior is to abort the MBReq message and handle the DBcmd message.

Verifying the Configuration

To verify the DBcmd Message when the MBreq Message for the Default Bearer is pending at the P-GW configuration, use the following command in Exec Mode:

```
show egtpc service all
```

```
Collision handling: DBcmd when MBreq pending: <Queue DBcmd>, <Drop DBcmd>, or <Abort MBreq and handle Dbcmd>
```

Monitoring the Collision Handling Feature

This section describes how to monitor the collision handling feature.

Collision Handling Show Command(s) and/or Outputs

This section provides information regarding show commands and/or their outputs in support of the collision handling on the P-GW/SAEGW/S-GW feature.

show configuration

The output of this command indicates if collision handling for the DBcmd message when the MBreq message is pending is enabled or disabled or for the mbreq over mbreq drop messages:

- collision-handling dbcnd-over-mbreq queue
- no collision-handling dbcnd-over-mbreq queue
- collision-handling mbreq-over-mbreq drop

show egtp-service all | name

The output of this command indicates how the P-GW is configured to handle the DBcmd Message when the MBreq message for the Default Bearer is pending at due to Drop MBreq or Abort MBreq and handle MBreq scenarios:

- Collision handling:
 - MBreq when MBreq pending

show egtp statistics verbose

The output of this command has been enhanced to provide detailed information for all supported GTPv2 message collisions at the P-GW/S-GW ingress interface, including:

- The interface on which the collision occurred.
- The ongoing procedure at eGTP-C when a new message arrived at the interface which caused the collision. The Msg Type in brackets specifies which message triggered this ongoing procedure.
- The new procedure and message type.
- The pre-defined action taken to handle the collision.
- The number of times each collision type has occurred.



Important

The *Message Collision Statistics* section of the command output appears only if any of the collision statistics have a counter total that is greater than zero.



CHAPTER 12

Disable Cause Source Enhancement

- [Feature Summary and Revision History, on page 307](#)
- [Feature Description, on page 308](#)
- [Configuring cause-source, on page 308](#)
- [Monitoring and Troubleshooting, on page 308](#)

Feature Summary and Revision History

Summary Data

Applicable Product(s) or Functional Area	<ul style="list-style-type: none">• S-GW• SAEGW
Applicable Platform(s)	ASR 5500
Feature Default	Disabled - Configuration Required
Related Changes in This Release	Not Applicable
Related Documentation	<ul style="list-style-type: none">• <i>Command Line Interface Reference</i>• <i>S-GW Administration Guide</i>• <i>SAEGW Administration Guide</i>

Revision History

Revision Details	Release
First introduced.	21.3

Feature Description

This feature introduces configuration changes that would allow you to configure the S-GW, including SAEGW instances, to disable the Cause Source bit functionality in Cause IE. If this configuration is enabled, S-GW and SAEGW always set the Cause Source Bit in Cause IE to zero.

Configuring cause-source

The `gtpc disable cause source` command has been introduced in support of this feature.

```
configure
  context context_name
    egtp-service egtp_service_name
      [ no | default ] gtpc disable cause-source
    end
```

Notes:

- **disable:** Disables functionality at egtpc level
- **cause-source:** Disables cause source Bit in Cause IE.

Monitoring and Troubleshooting

This section provides information on how to monitor and troubleshoot using show commands and bulk statistics available to support of this feature.

Show Commands and/or Outputs

This section provides information regarding show commands and their outputs for the Disable Cause Source feature.

show egtp-service name egtp

This command displays the following output:

```
Service name                : egtp_sgwil...
Reject S2b HO(No UE Context) : Disabled
GTPC Cause Source bit in Cause IE : [Enabled/Disabled]
```

Troubleshooting

The following commands can be used for troubleshooting:

- The following commands can be used for checking current status of this feature:

```
show egtp-service name service_name
```

- Monitor protocol CLI can be enabled to check GTPV2 protocol trace. In the protocol trace output cause source bit in Cause IE can be checked.



CHAPTER 13

Direct Tunnel for 4G (LTE) Networks

This chapter briefly describes support for direct tunnel (DT) functionality over an S12 interface for a 4G (LTE) network to optimize packet data traffic.

Cisco LTE devices (per 3GPP TS 23.401 v8.3.0) supporting direct tunnel include:

- Serving GPRS Support Node (S4-SGSN)
- Serving Gateway (S-GW)
- PDN Gateway (P-GW)



Important Direct Tunnel is a licensed Cisco feature. A separate feature license is required for configuration. Contact your Cisco account representative for detailed information on specific licensing requirements. For information on installing and verifying licenses, refer to the *Managing License Keys* section of the *Software Management Operations* chapter in the *System Administration Guide*.

The following sections are included in this chapter:

- [Direct Tunnel for 4G Networks - Feature Description](#) , on page 311
- [How It Works](#), on page 314
- [Configuring Support for Direct Tunnel](#), on page 338
- [Monitoring and Troubleshooting Direct Tunnel](#), on page 341

Direct Tunnel for 4G Networks - Feature Description

The amount of user plane data will increase significantly during the next few years because of High Speed Packet Access (HSPA) and IP Multimedia Subsystem technologies. Direct tunneling of user plane data between the RNC and the S-GW can be employed to scale UMTS system architecture to support higher traffic rates.

Direct Tunnel (DT) offers a solution that optimizes core architecture without impact to UEs and can be deployed independently of the LTE/SAE architecture.



Important Direct tunnel is a licensed Cisco feature. A separate feature license is required for configuration. Contact your Cisco account representative for detailed information on specific licensing requirements. For information on installing and verifying licenses, refer to the *Managing License Keys* section of the *Software Management Operations* chapter in the *System Administration Guide*.



Important Establishment of a direct tunnel is controlled by the SGSN; for 4G networks this requires an S4 license-enabled SGSN setup and configured as an S4-SGSN.

Once a direct tunnel is established, the S4-SGSN/S-GW continues to handle the *control plane* (RANAP/GTP-C) signaling and retains the responsibility of making the decision to establish direct tunnel at PDP context activation.

Figure 56: GTP-U Direct Tunneling

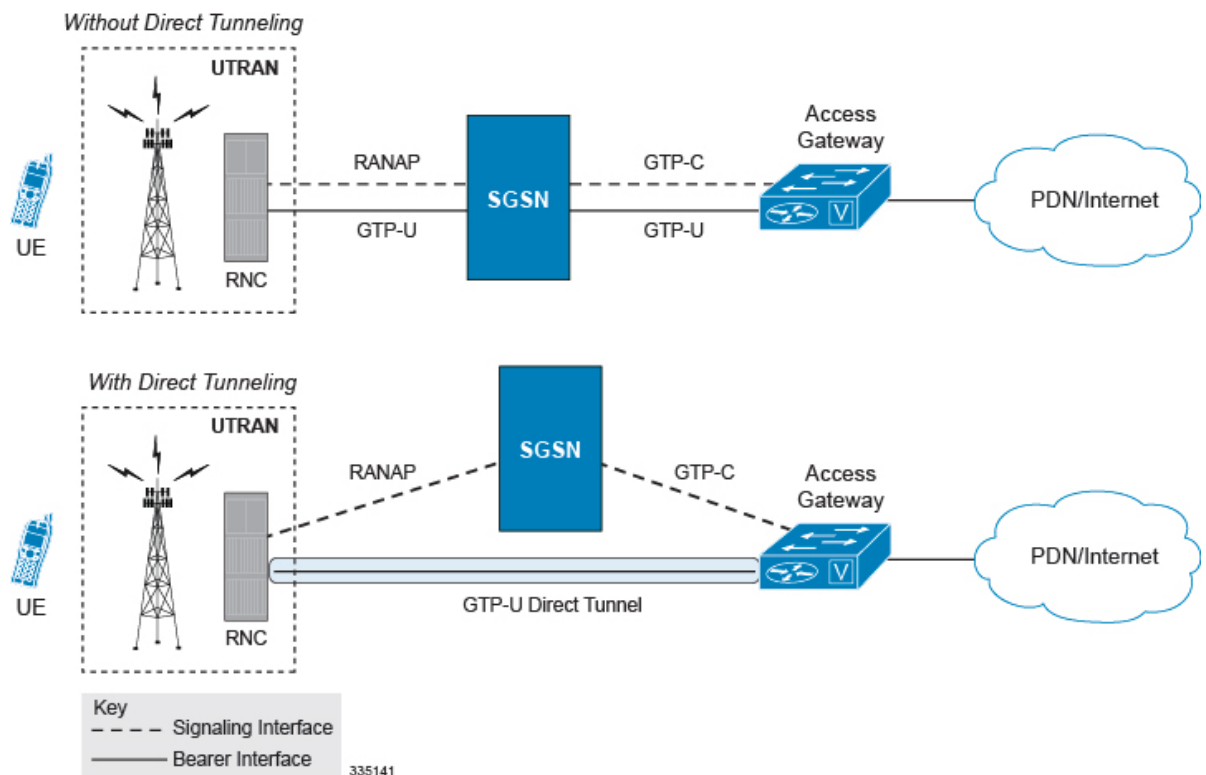

A direct tunnel improves the user experience (for example, expedites web page delivery, reduces round trip delay for conversational services) by eliminating switching latency from the user plane. An additional advantage, direct tunnel functionality implements optimization to improve the usage of user plane resources (and hardware) by removing the requirement from the S4-SGSN/S-GW to handle the user plane processing.

A direct tunnel is achieved upon PDP context activation when the S4-SGSN establishes a user plane tunnel (GTP-U tunnel) directly between the RNC and the S-GW over an S12 interface, using a Create Bearer Response or Modify Bearer Request towards the S-GW.

Figure 57: Direct Tunneling - LTE Network, S12 Interface

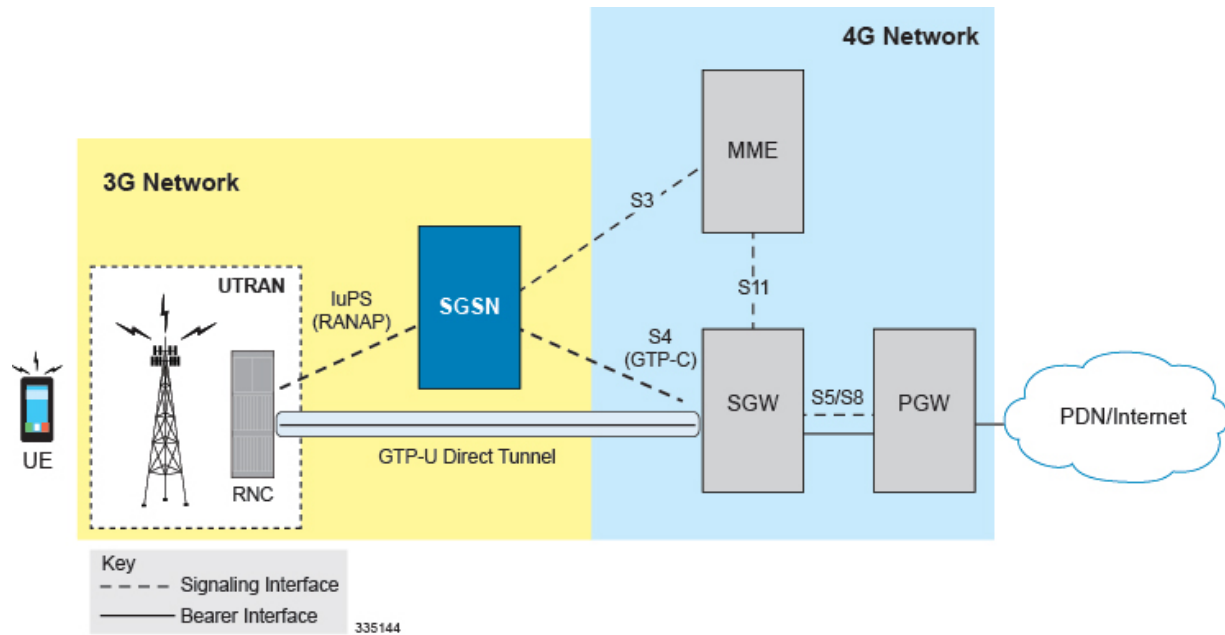

A major consequence of deploying a direct tunnel is that it produces a significant increase in control plane load on both the SGSN/S-GW and GGSN/P-GW components of the packet core. Hence, deployment requires highly scalable GGSNs/P-GWs since the volume and frequency of Update PDP Context messages to the GGSN/P-GW will increase substantially. The SGSN/S-GW platform capabilities ensure control plane capacity will not be a limiting factor with direct tunnel deployment.

S4-SGSN supports establishment of a GTP-U direct tunnel between an RNC and the S-GW under the scenarios listed below:

- Primary PDP activation
- Secondary PDP activation
- Service Request Procedure
- Intra SGSN Routing Area Update without S-GW change
- Intra SGSN Routing Area Update with S-GW change
- Intra SGSN SRNS relocation without S-GW change
- Intra SGSN SRNS relocation with S-GW change
- New SGSN SRNS relocation with S-GW change
- New SGSN SRNS relocation without S-GW relocation
- E-UTRAN-to-UTRAN Iu mode IRAT handover with application of S12U FTEID for Indirect Data Forwarding Tunnels as well
- UTRAN-to-E-UTRAN Iu mode IRAT handover with application of S12U FTEID for Indirect Data Forwarding Tunnels as well
- Network Initiated PDP Activation

Scenarios that vary at S4-SGSN when direct tunneling is enabled, as compared to DT on a 2G or 3G SGSN using the Gn interface, include:

- RAB Release
- Iu Release
- Error Indication from RNC

- Downlink Data Notification from S-GW
- Downlink Data Error Indication from S-GW
- MS Initiated PDP Modification
- P-GW Initiated PDP Modification while the UE is IDLE
- HLR/HSS Initiated PDP Modification
- Session Recovery with Direct Tunnel

The above scenarios exhibit procedural differences in S4-SGSN when a direct tunnel is established.

How It Works

DT functionality enables direct user plane tunnel between RNC and SGW within the PS domain. With direct tunneling the S4-SGSN provides the RNC with the TEID and user plane address of the S-GW, and also provides the S-GW with the TEID and user plane address of the RNC.

The SGSN handles the control plane signaling and makes the decision when to establish the direct tunnel between RNC and S-GW, or use two tunnels for this purpose (based on configuration).

DT Establishment Logic

The following figure illustrates the logic used within the S4-SGSN/S-GW to determine if a direct tunnel will be setup.

Figure 58: Direct Tunneling - Establishment Logic

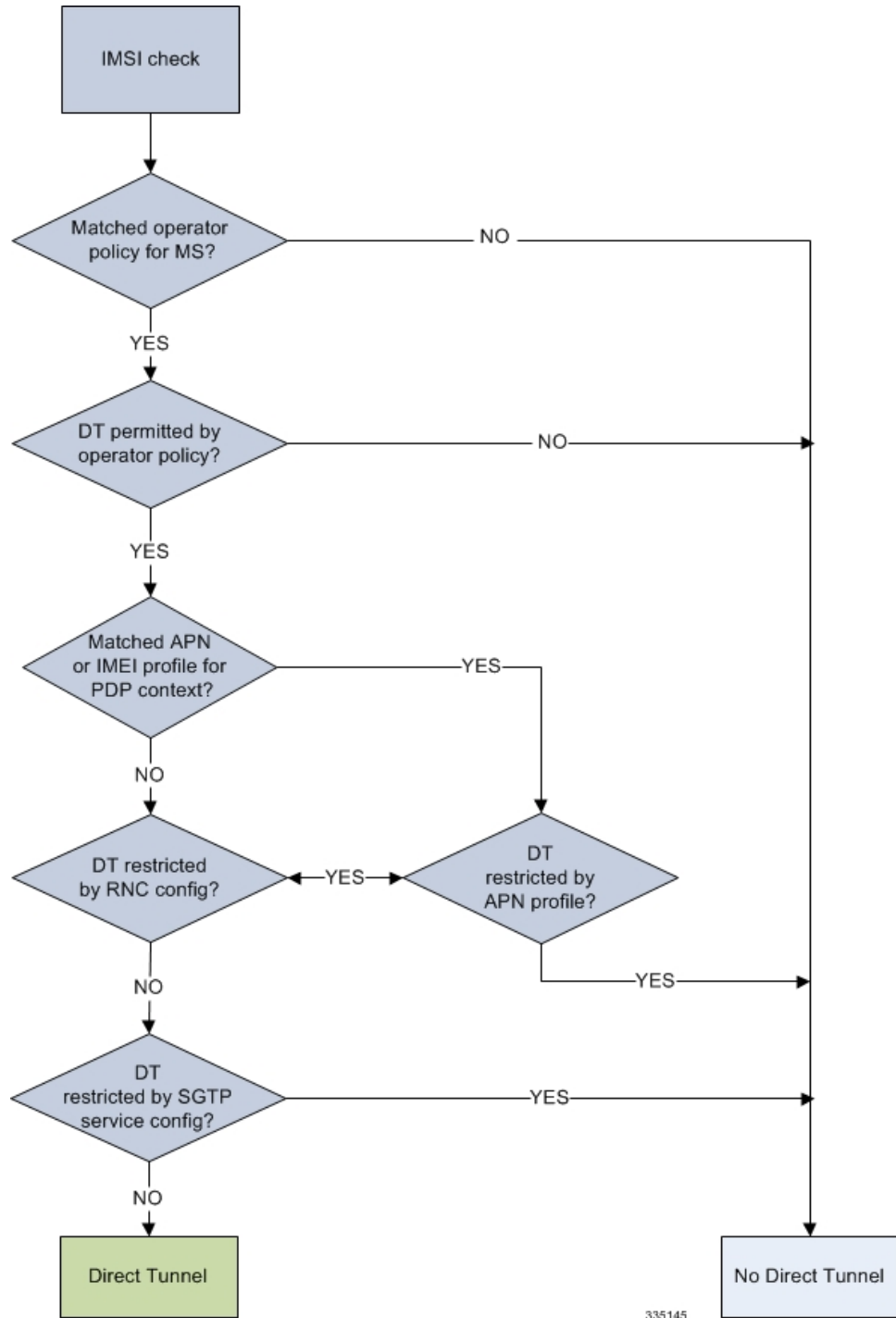

Establishment of Direct Tunnel

The S4-SGSN uses the S12 interface for DT.

Direct Tunnel Activation for Primary PDP Context

For the PDP Context Activation procedure this solution uses new information elements (IEs) for the GPRS Tunnelling Protocol v2 (GTPv2) as defined in TS 29.274. SGSN provides the user plane addresses for RNC and S-GW as S12U FTEIDs as illustrated in the figure below.

The sequence for establishing a direct tunnel between the RNC and S-GW during PDP activation is as follows:

- SGSN sends a Create Session Request to the S-GW with the indication flag DTF (direct tunnel flag) bit set
- In its Create Session Response, the S-GW sends the SGSN an S12U FTEID (Fully Qualified Tunnel Endpoint Identifier).
- The SGSN forwards the S-GW S12U to the RNC during the RAB Assignment Request.
- In its RAB Assignment Response, the RNC sends the SGSN its transport address and Tunnel Endpoint ID (TEID).
- The SGSN forward the RNC S12U FTEID o the S-GW via a Modify Bearer Request.

Figure 59: Primary PDP Activation with Direct Tunnel

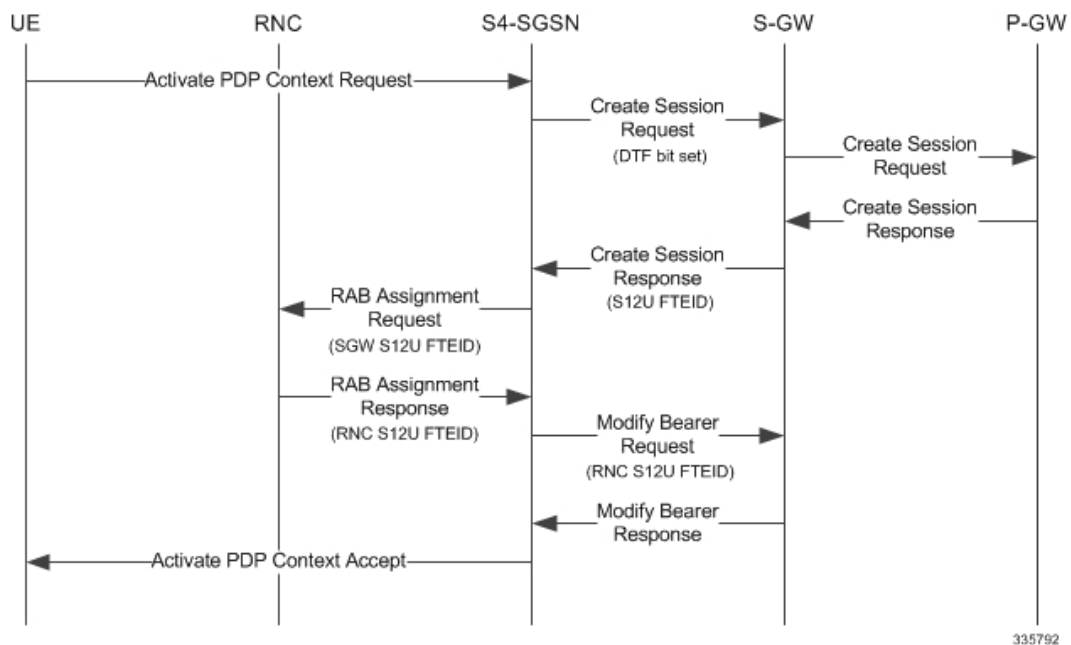

335792

Direct Tunnel Activation for UE Initiated Secondary PDP Context

The following is the general sequence for establishing a direct tunnel for a Secondary PDP Context Activation:

- The SGSN sends a Bearer Resource Command to the S-GW with no flags set. (S-GW already knows Direct Tunnel is enabled for primary.)
- The S-GW sends a Create Bearer Response that includes the S12U FTEID to the SGSN.
- The SGSN forwards the S-GW S12U to RNC via a RAB Assignment Request.
- In its RAB Assignment Response, the RNC sends its transport address and TEID to the SGSN.
- The SGSN forwards the S12U TEID received from the RNC to the S-GW via a Create Bearer Response.

Figure 60: Secondary PDP Activation with Direct Tunnel

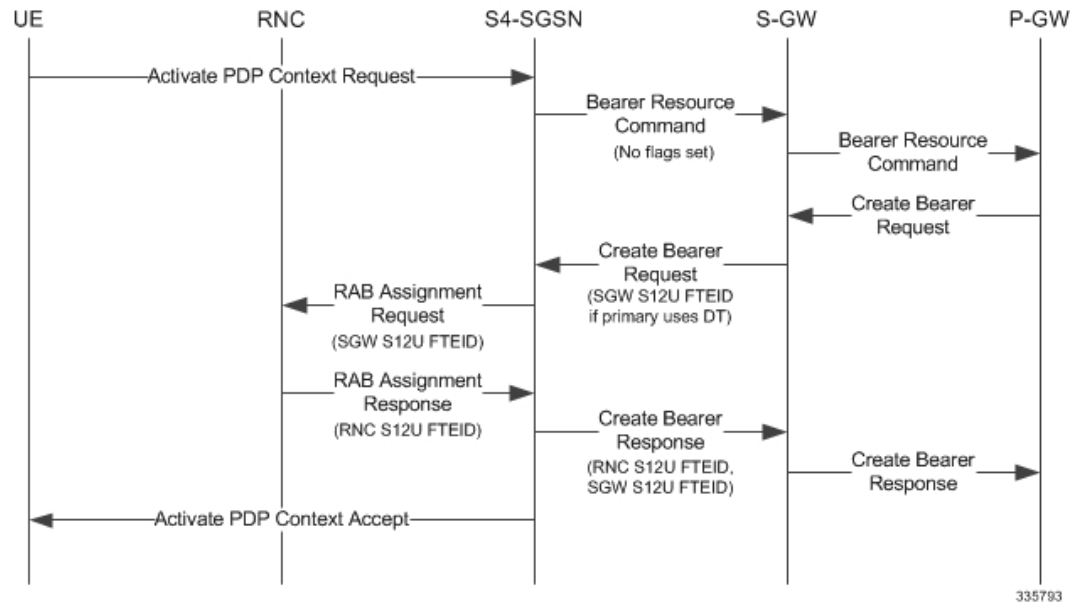

RAB Release with Direct Tunnel

If the SGSN receives a RAB Release Request from the RNC for bearer contexts activated with Direct Tunnel, it sends a Release Access Bearer Request to the S-GW.

Upon receiving the Release Access Bearer Request, the S-GW removes the S12 U RNC FTEID. If any downlink data appears, the S-GW sends a Downlink Data Notification because it does not have a user plane FTEID with which to forward data.

Bearers with a streaming or conversational class will not be included in the Release Access Bearer Request because these bearers should be deactivated. However, S4-SGSN currently does not support deactivation of streaming/conversational bearers upon RAB release.

Figure 61: RAB Release Procedure with Direct Tunnel

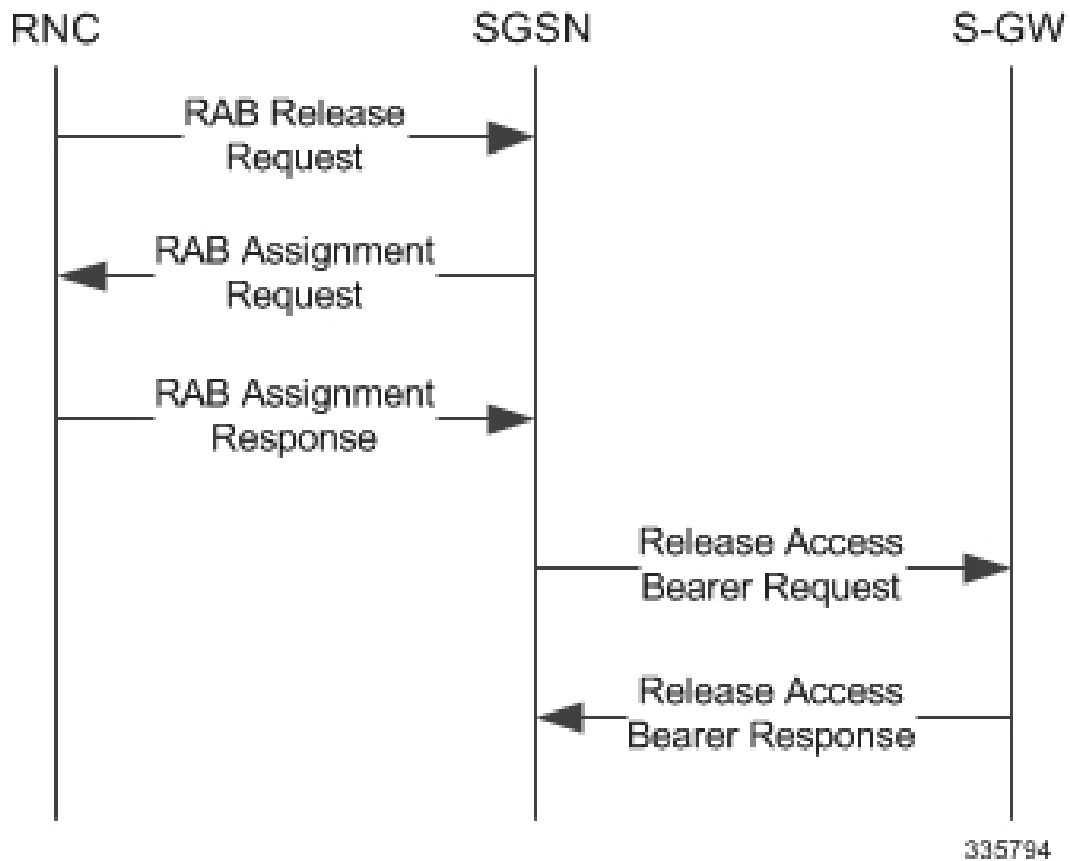

Important Operators should not use conversational or streaming class bearers in S4-SGSN.

Iu Release with Direct Tunnel

If the SGSN receives an Iu Release and bearers are activated with direct tunneling, it sends a Release Access Bearer Request to the S-GW.

Bearers with a streaming or conversational class will not be included in the Release Access Bearer Request because these bearers should be deactivated. However, S4-SGSN currently does not support deactivation of streaming or conversational bearers upon Iu release.



Important Operators should not use conversational or streaming class bearers in S4-SGSN.

Figure 62: Iu Release Procedure with Direct Tunnel

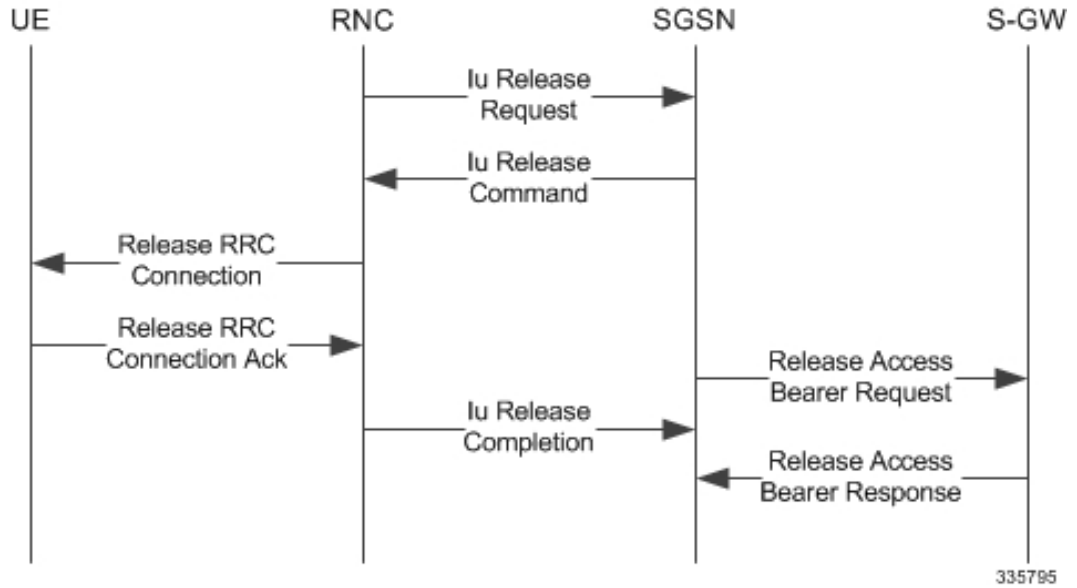

Service Request with Direct Tunnel

When a UE is Idle and wants to establish a data or signaling connection, it sends a Service Request for data. Alternatively a UE can also send a Service Request to the SGSN when it is paged by the SGSN.

Upon receiving a Service Request for data, the SGSN establishes RABs and sends a Modify Bearer Request to the S-GW with the 12U FTEID received from the RNC.

Figure 63: Service Request Procedure with Direct Tunnel

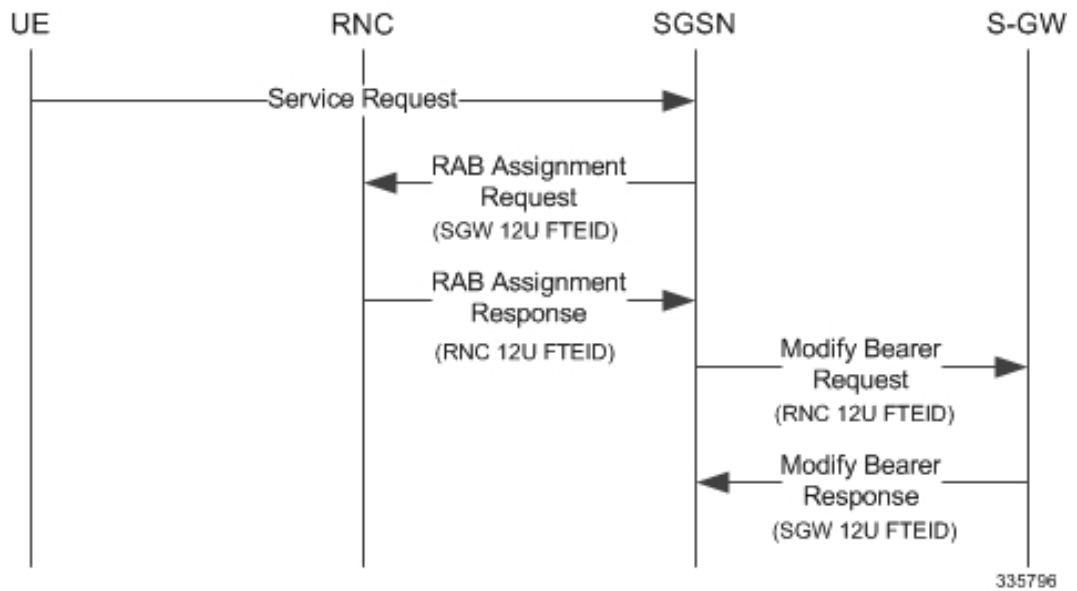

Downlink Data Notification with Direct Tunnel when UE in Connected State

When RABs are released (but UE retains an Iu connection with the SGSN), the SGSN notifies the S-GW to release the RNC side TEIDs via a Release Access Bearer Request.

If the S-GW receives any downlink GTPU data from the P-GW after receiving the Release Access Bearer Request, it knows neither the RNC TEID nor SGSN user plane TEID to which to forward the data. So it signals the SGSN to establish the RABs. This signaling message is a Downlink Data Notification message from the S-GW.

If the Downlink Data Notification is received from the S-GW, all of the missing RABs are established and a Modify Bearer Request is sent to the S-GW with the RNC S12U FTEID.

Figure 64: Downlink Data Notification with Direct Tunnel

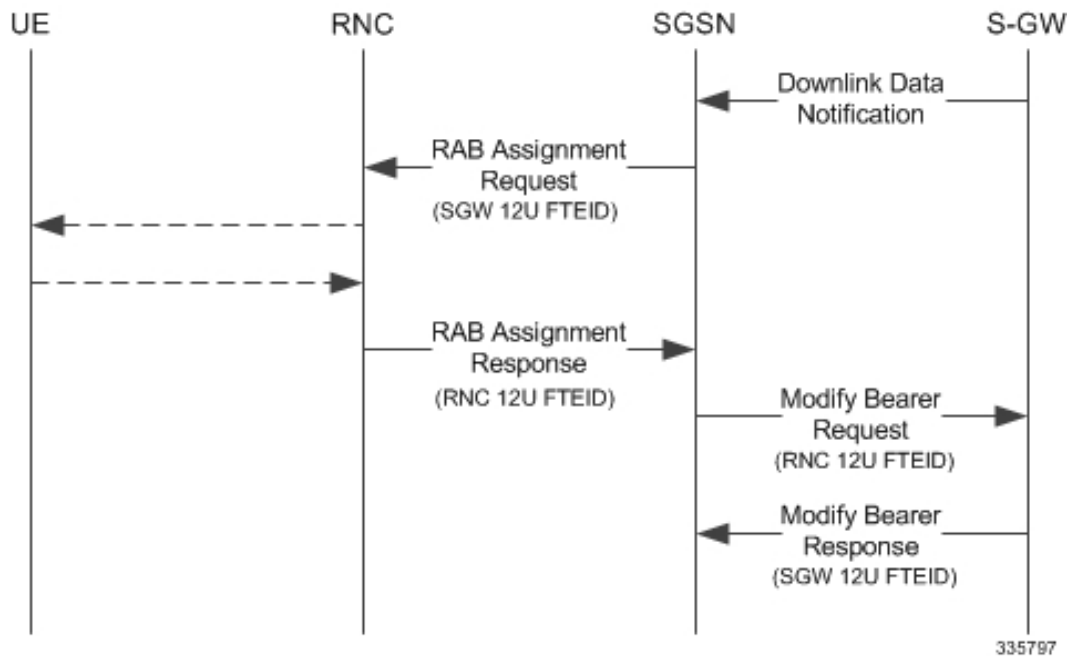

Downlink Data Notification with Direct Tunnel when UE in Idle State

When an Iu is released the UE goes IDLE. The SGSN informs the S-GW to release the RNC side TEIDs by sending a Release Access Bearer Request. After this point if the S-GW receives any downlink GTPU data from the P-GW, it knows neither the RNC TEID nor SGSN user plane TEID to which to forward the data.

If the S-GW receives any downlink GTPU data after receiving the Release Access Bearer Request, it knows neither the RNC TEID nor SGSN user plane TEID to which to forward the data. So it signals the SGSN to establish the RABs. This signaling message is a Downlink Data Notification from the S-GW. If a Downlink Data Notification is received from S-GW when the UE is idle, the SGSN pages the UE before establishing the RABs. The SGSN sends a Modify Bearer Request to the S-GW with the RNC S12U FTEID.

Figure 65: Downlink Data Notification when UE in Idle State

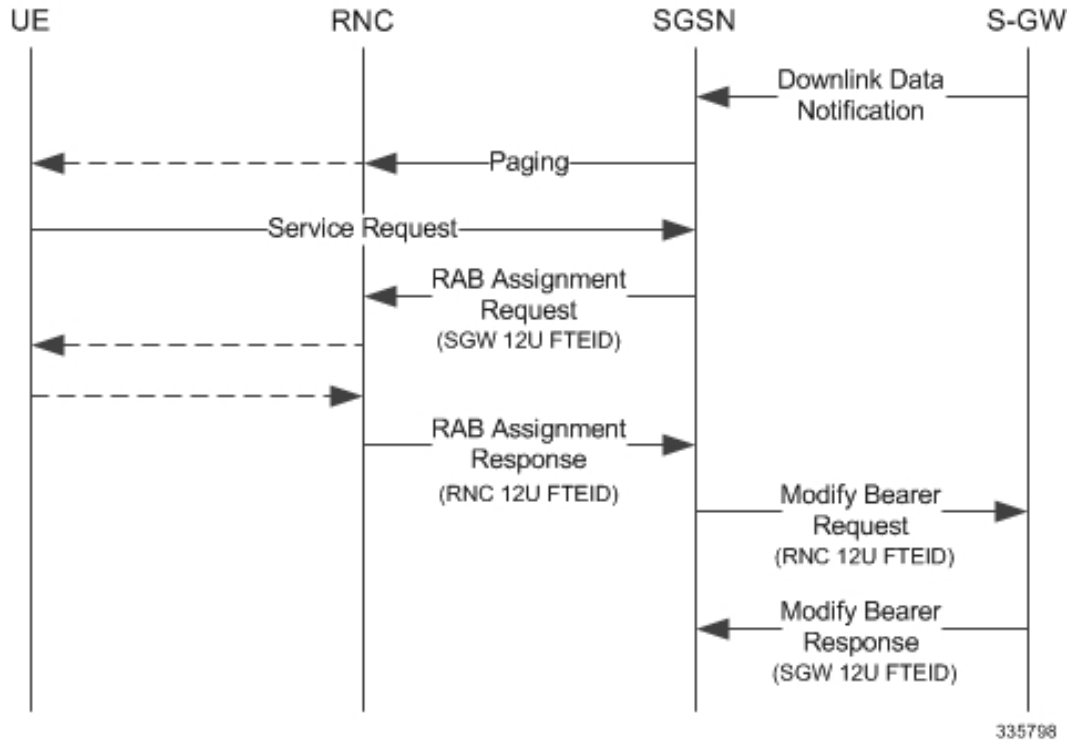

Intra SGSN Routing Area Update without SGW Change

For a Routing Area Update without an S-GW change with Direct Tunnel, the SGSN sends a Modify Bearer Request to the S-GW with the RNC FTEID. The SGSN will establish RABs with the target RNC only if the RABs were present with the source RNC.

Figure 66: Routing Area Update Procedure without SGW Change

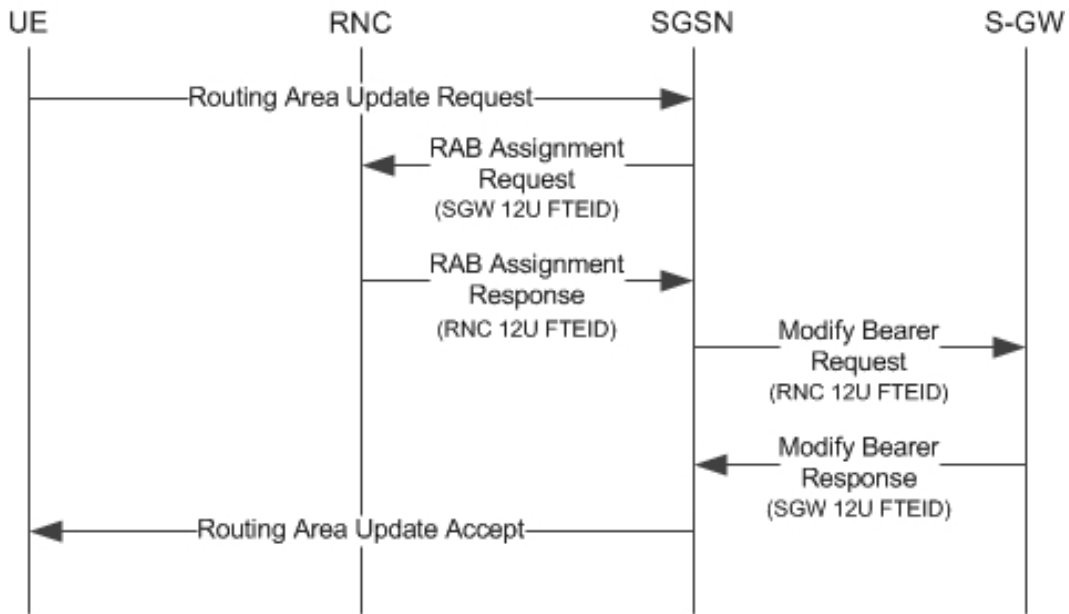

335799

The table below includes detailed behaviors for a Routing Area Update without S-GW change.

Table 31: Routing Area Update without S-GW Change Behavior Table

Scenario	Old RNC Status	Old RNC RAB	Old RNC DT Status	PLMN Change	NEW RNC DT Status	S-GW Change	SGSN Action
Intra RAU	Not Present	No RAB	Supported	No	Supported	No	No RAB establishment with new RNC. No Modify Bearer Request to S-GW
Intra RAU	Present	No RAB	Supported	No	Supported	No	No RAB establishment with new RNC. No Modify Bearer Request to S-GW
Intra RAU	Present	Some RABs	Supported	Do not care	Supported	No	Only the present RABs are established. MBR sent to S-GW with the bearers with RABs that are be modified and the rest released. The bearers without RABs will be deactivated post RAU. If PLMN changed then MBR will carry the new PLMN ID.

Scenario	Old RNC Status	Old RNC RAB	Old RNC DT Status	PLMN Change	NEW RNC DT Status	S-GW Change	SGSN Action
Intra RAU	Not Present	No RAB	Supported	Yes	Supported	No	No RAB establishment with new RNC. MBR is sent with only PLMN change. Bearer Context will not carry any TEID.
Intra RAU	Present	No RAB	Supported	Yes	Supported	No	Same as above.
Intra RAU	Not Present	No RAB	Not Supported	No	Supported	No	No RAB establishment with new RNC. Modify Bearer Request to S-GW with DTF set and no user FTEID.
Intra RAU	Present	No RAB	Not Supported	No	Supported	No	Same as above.
Intra RAU	Present	Some RABs	Not Supported	Do not care	Supported	No	Only the present RABs are established. MBR sent to S-GW with the bearers with RABs to be modified and the rest to be released. The bearers without RABs will be deactivated post RAU. If PLMN changed then MBR will carry the new PLMN ID. Modify Bearer.
Intra RAU	Not Present	No RAB	Not Supported	Yes	Supported	No	No RAB establishment with new RNC. MBR is sent with only PLMN change. SGSN will page / Service request / establish RABs when a downlink data notification is received.
Intra RAU	Present	No RAB	Not Supported	Yes	Supported	No	Same as above.

Intra RAU: New RNC does not support Direct Tunnel. No SGW relocation

Scenario	Old RNC Status	Old RNC RAB	Old RNC DT Status	PLMN Change	NEW RNC DT Status	S-GW Change	SGSN Action
Intra RAU	Not Present	No RAB	Supported	Do not care	Not Supported	No	No RAB establishment with new RNC. SGSN sends Modify Bearer Request to S-GW with S4U TEID. If there is change in PLMN ID, then new PLMN ID will be carried.
Intra RAU	Present	No RAB	Supported	Do not care	No Supported	No	Same as above.
Intra RAU	Present	Some RABs	Supported	Do not care	Not supported	No	Only the present RABs are established. MBR sent to S-GW with all bearers having S4U TEID. If there is change in PLMN ID, the new PLMN ID will be carried.

Routing Area Update with S-GW Change

In a Routing Area Update with an S-GW change, the SGSN sends a Create Session Request with DTF flag set and no user plane FTEID. In its Create Session Response, the S-GW sends an S12U FTEID which is forwarded to the RNC via a RAB Assignment Request.

The SGSN sends the RNC FTEID received in the RAB Assignment Response to the S-GW in a Modify Bearer Request. There are many scenarios to consider during Intra SGSN RAU.

Figure 67: Routing Area Update Procedure with SGW Change

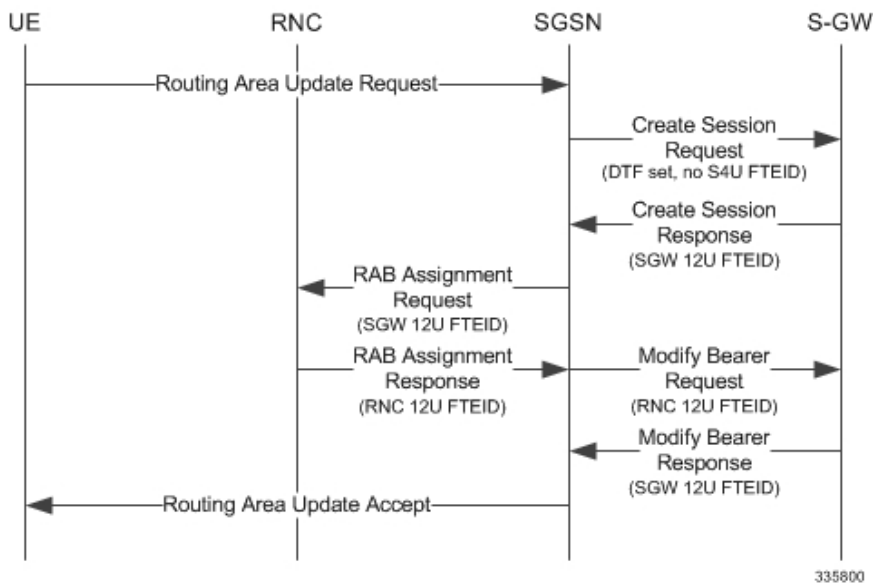

335800

The table below includes detailed behaviors for a Routing Area Update with S-GW change.

Table 32: Routing Area Update with S-GW Change Behavior Table

Scenario	Old RNC Status	Old RNC RAB	Old RNC DT Status	PLMN Change	NEW RNC DT Status	S-GW Change	SGSN Action
Intra RAU: Both RNCs support Direct Tunnel. SGW relocation							
Intra RAU	Not Present	No RAB	Supported	Do not care	Supported	Yes	Send CSR request to new S-GW with DTF flag but no S4U / S12U FTEID. S-GW will send its S12U TEID that SGSN stores as part of DP's remote TEID. SGSN will not initiate any MBR request to S-GW since no RABs are established with new RNC. If S-GW subsequently gets downlink data, SGSN will get DDN and establish RABs and send MBR.
Intra RAU	Present	No RAB	Supported	Do not care	Supported	Yes	Same as above.
Intra RAU	Present	Some RABs	Supported	Do not care	Supported	Yes	Send CSR request to new S-GW with DTF flag but no S4U / S12U FTEID. S-GW sends its S12U TEID. RABs that are present will be established with new RNC. MBR will be initiated only with those RABs that are present rest of bearers to be removed
Intra RAU: Old RNC does not support Direct Tunnel. SGW relocation							

Scenario	Old RNC Status	Old RNC RAB	Old RNC DT Status	PLMN Change	NEW RNC DT Status	S-GW Change	SGSN Action
Intra RAU	Not Present	No RAB	Not Supported	Do not care	Supported	Yes	Send CSR request to new S-GW with DTF flag but no S4U / S12U FTEID. S-GW sends its S12U TEID that SGSN stores as part of our DP's remote TEID. SGSN will not initiate any MBR request to S-GW since no RABs are established with new RNC. If S-GW subsequently gets downlink data, SGSN gets DDN and establishes RABs and sends MBR.
Intra RAU	present	No RAB	Not Supported	Do not care	Supported	Yes	Same as above.
Intra RAU	Present	Some RABs	Not Supported	Do not care	Supported	Yes	Send CSR request to new S-GW with DTF flag but no S4U / S12U FTEID. S-GW sends its S12U TEID. RABs that are present will be established with new RNC and MBR will be initiated only with those RABs that are present and the rest as bearers to be removed.
Intra RAU: New RNC does not support Direct Tunnel. SGW relocation							
Intra RAU	Not Present	No RAB	Supported	Do not care	Not Supported	Yes	CSR request without DTF flag and with S4U FTEID.
Intra RAU	Present	No RAB	Supported	Do not care	Not Supported	Yes	CSR request without DTF flag and with S4U FTEID.
Intra RAU	Present	Some RABs	Supported	Do not care	Not Supported	Yes	CSR request without DTF flag and with S4U FTEID. No deactivation of PDPs.

Intra SRNS with S-GW Change

In Intra SRNS (Serving Radio Network Subsystem) with S-GW change, the SGSN sends a Create Session Request with DTF flag set and no user plane FTEID. The Create Session Response from the new S-GW contains the SGW S12U FTEID which the SGSN forwards to the Target RNC in a Relocation Request.

The SGSN sends the RNC S12U FTEID to the new S-GW in a Modify Bearer Request.

Figure 68: Intra SRNS with S-GW Change

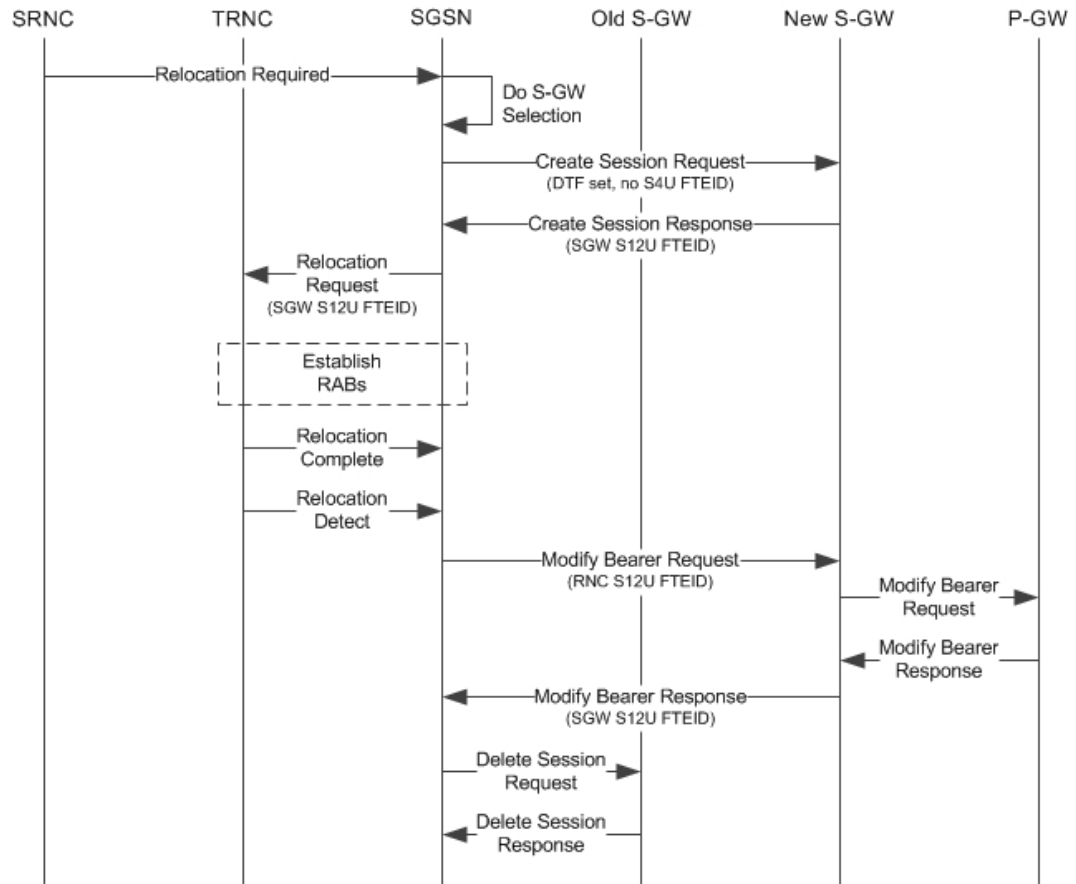

335801

The table below includes detailed behaviors for intra SRNS scenarios.

Intra SRNS without S-GW Change

In Intra SRNS without S-GW change, a Relocation Request is sent with SGW S12U FTEID. The RNC S12U FTEID received is forwarded to the S-GW in a Modify Bearer Request.

Figure 69: Intra SRNS without S-GW Change

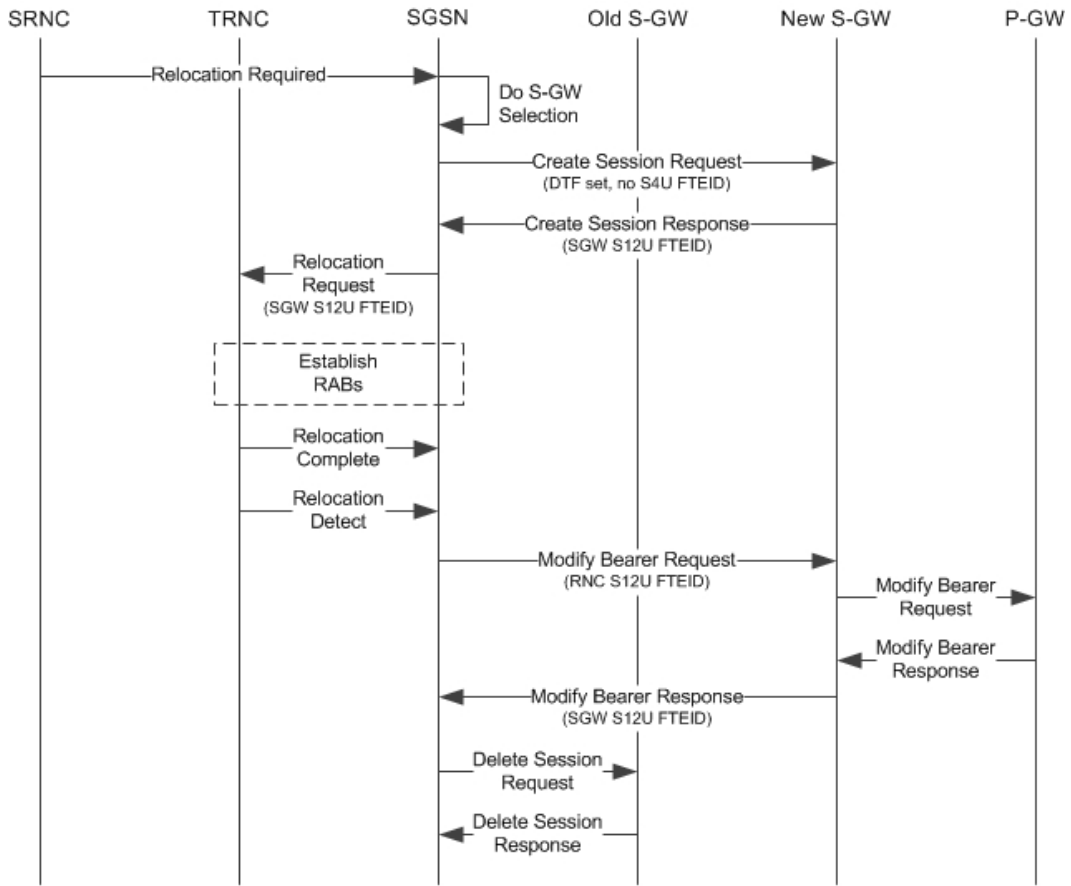

335801

The table below includes detailed behaviors for intra SRNS scenarios.

Table 33: Intra SRNS Behaviors

Old RNC DT Status	New RNC DT Status	S-GW Relocation	Behavior
Supported	Supported	No	Relocation Request to Target RNC is sent with S-GW S12 U FTEID. Modify Bearer Request to S-GW is sent with RNC S12 U FTEID.
Supported	Not Supported	No	Relocation Request to Target RNC is sent with SGSN S4 U FTEID. Modify Bearer Request to S-GW is sent with SGSN S4 U FTEID
Not Supported	Supported	No	Relocation Request to Target RNC is sent with S-GW S12U FTEID. Modify Bearer Request to S-GW is sent with RNC S12 U FTEID.

Old RNC DT Status	New RNC DT Status	S-GW Relocation	Behavior
Not Supported	Supported	Yes	Create Session Request to new S-GW is sent with DTF flag set and no user plane FTEID. Even if S-GW sent S4U FTEID in CSR Response SGSN internally treats that as an S12U FTEID and continues the relocation. Relocation Request to Target RNC is sent with S12 U FTEID received in Create Session Response. Modify Bearer Request to new S-GW is sent with RNC S12U FTEID
Supported	Not Supported	Yes	Create Session Request to new SGW is sent with S4 U FTEID. Relocation Request to Target RNC is sent with SGSN U FTEID. Modify Bearer Request is sent with SGSN S4U FTEID.
Supported	Supported	Yes	SGSN sends a Create Session Request to new SGW with DTF flag set and no user plane FTEID. Even if S-GW sent S4U FTEID in CSR Response, SGSN will internally treat that as S12U FTEID and continue the relocation. Relocation Request to the Target RNC is sent with the S12 U FTEID received in the Create Session Response. Modify Bearer Request to new S-GW is sent with RNC U FTEID.

New SRNS with S-GW Change and Direct Data Transfer

The new SGSN sends a Create Session Request with DTF flag set and no user plane FTEID to the new S-GW. The new SGSN sends the SGW S12U FTEID received in the Create Session Response in Relocation Request to the Target RNC. The new SGSN sends the RNC S12U FTEID received in a Relocation Request Ack to the new S-GW in a Modify Bearer Request.

Figure 70: New SRNS with S-GW Change with Data Transfer

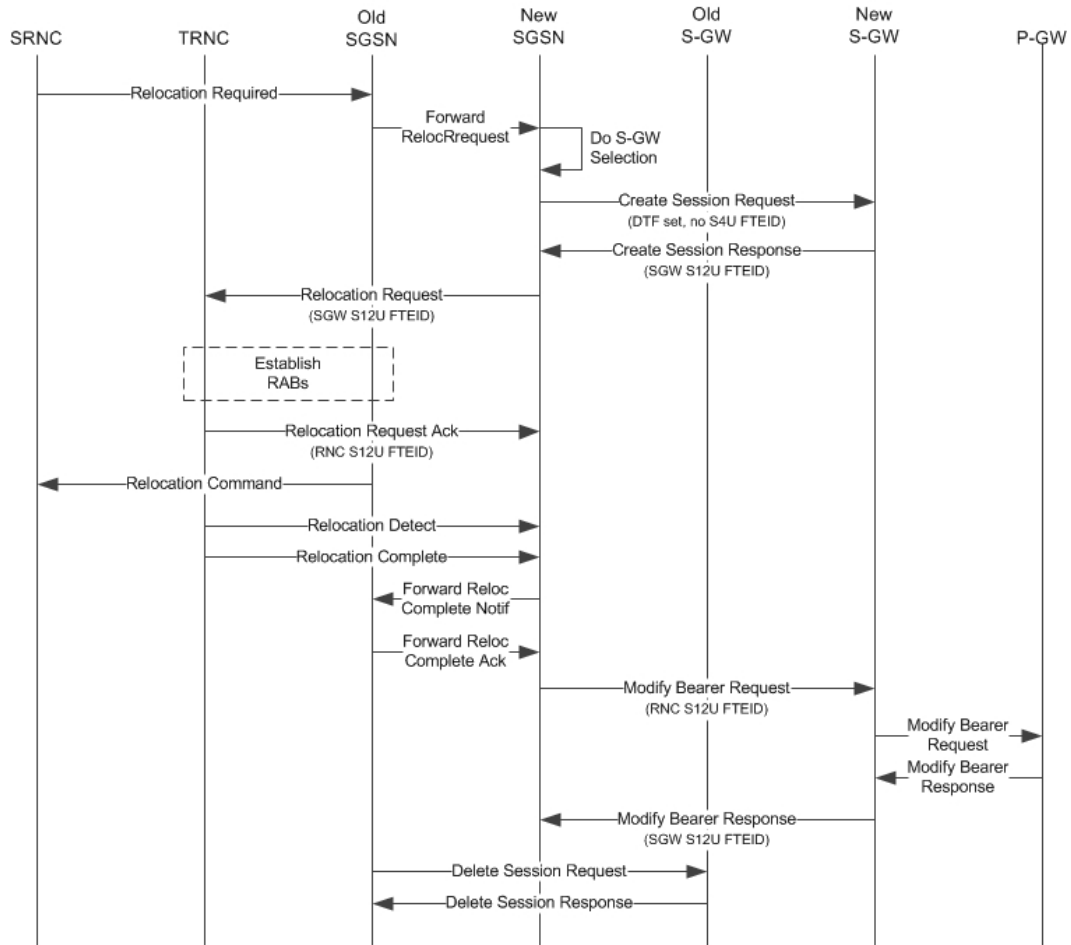

335803

The table below includes detailed behaviors for New SRNS scenarios.

New SRNS with S-GW Change and Indirect Data Transfer

Indirect Data Transfer (IDFT) during a new SGSN SRNS happens during E-UTRAN-to-UTRAN connected mode IRAT handover. See the figure below for a detailed call flow.

Figure 71: New SRNS with S-GW Change and Indirect Data Transfer

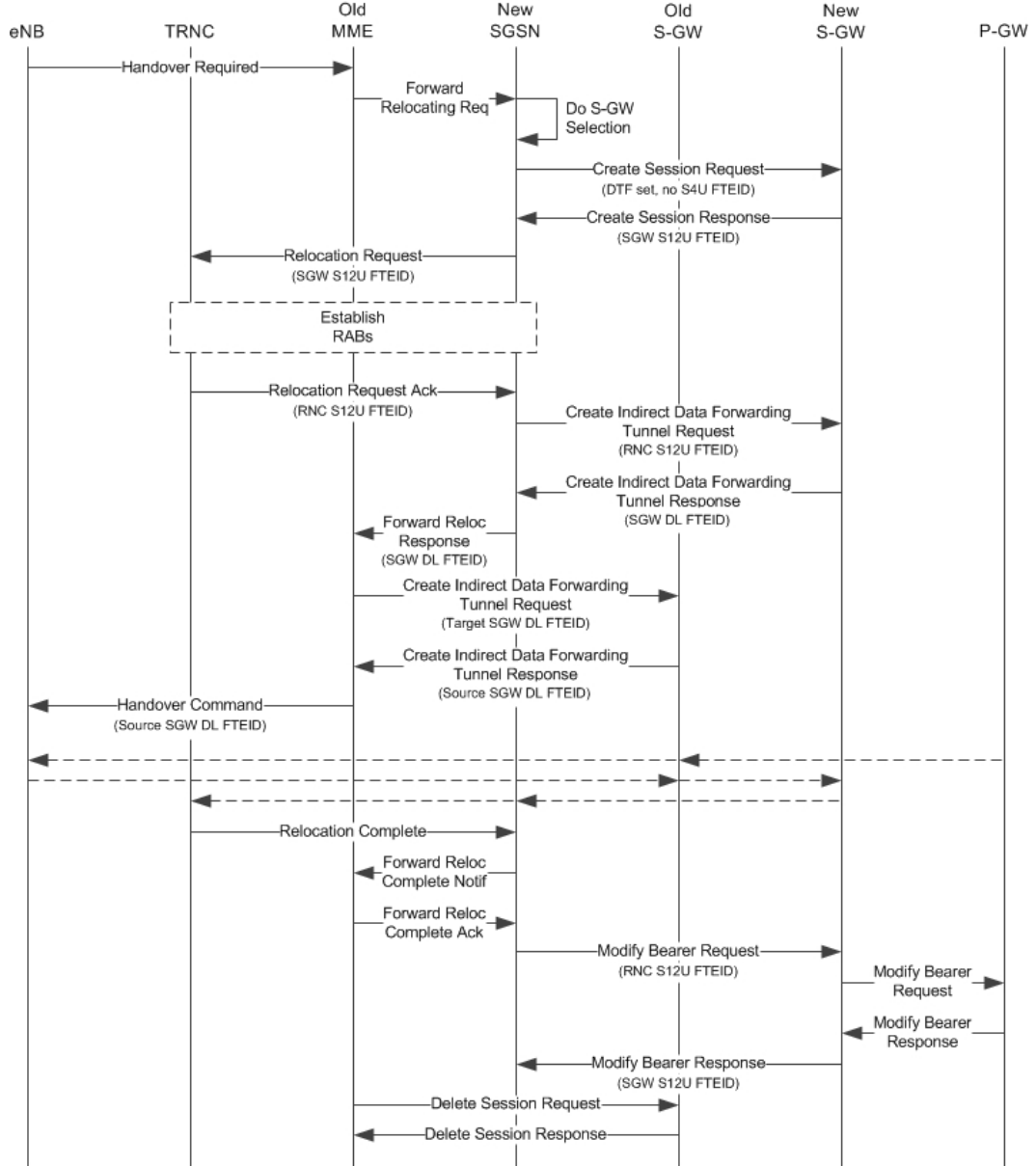

335804

The table below includes detailed behaviors for New SRNS scenarios.

Table 34: New SRNS Behaviors

Target RNC DT Status	Direct Forwarding	S-GW Relocation	Behavior
Supported	No	No	Relocation Request with SGW S12U FTEID received in Forward Relocation Request. SGSN includes RNC U FTEID in Forward Relocation Response. RNC U FTEID is also sent in Modify Bearer Request with DTF flag set.

Target RNC DT Status	Direct Forwarding	S-GW Relocation	Behavior
Supported	Yes	No	Relocation Request with SGW S12U FTEID received in Forward Relocation Request. In Forward Relocation Response RNC U FTEID is included. And in Modify Bearer Request RNC U FTEID is sent and DTF flag is set.
Supported	No	Yes	Create Session Request with DTF flag set and no user plane FTEID. Relocation Request is sent with SGW S12U FTEID received in Create Session Response. Even if SGW sent S4U FTEID in CSR Response we will internally treat that as S12U FTEID and continue the relocation. Create Indirect Data Forwarding Tunnel Request is sent with RNC FTEID received in Relocation Request Acknowledge. In Forward Relocation Response SGW DL U FTEID received in Create IDFT response is sent. Modify Bearer Request is sent with DTF set and RNC U FTEID.
Supported	Yes	Yes	Create Session Request with DTF flag set and no user plane FTEID. Relocation Request is sent with SGW S12U FTEID received in Create Session Response. Even if SGW sent S4U FTEID in CSR Response we will internally treat that as S12U FTEID and continue the relocation. In Forward Relocation Response RNC FTEID is sent and Modify Bearer Request is sent with DTF flag set and RNC U FTEID

Old SRNS with Direct Data Transfer

This scenario includes SRNS relocation between two SGSNs and hence IDFT is not applicable. Data will be forwarded between the source and target RNCs directly. Forward Relocation Request is sent with S12U FTEID.

Figure 72: Old SRNS with Direct Data Transfer

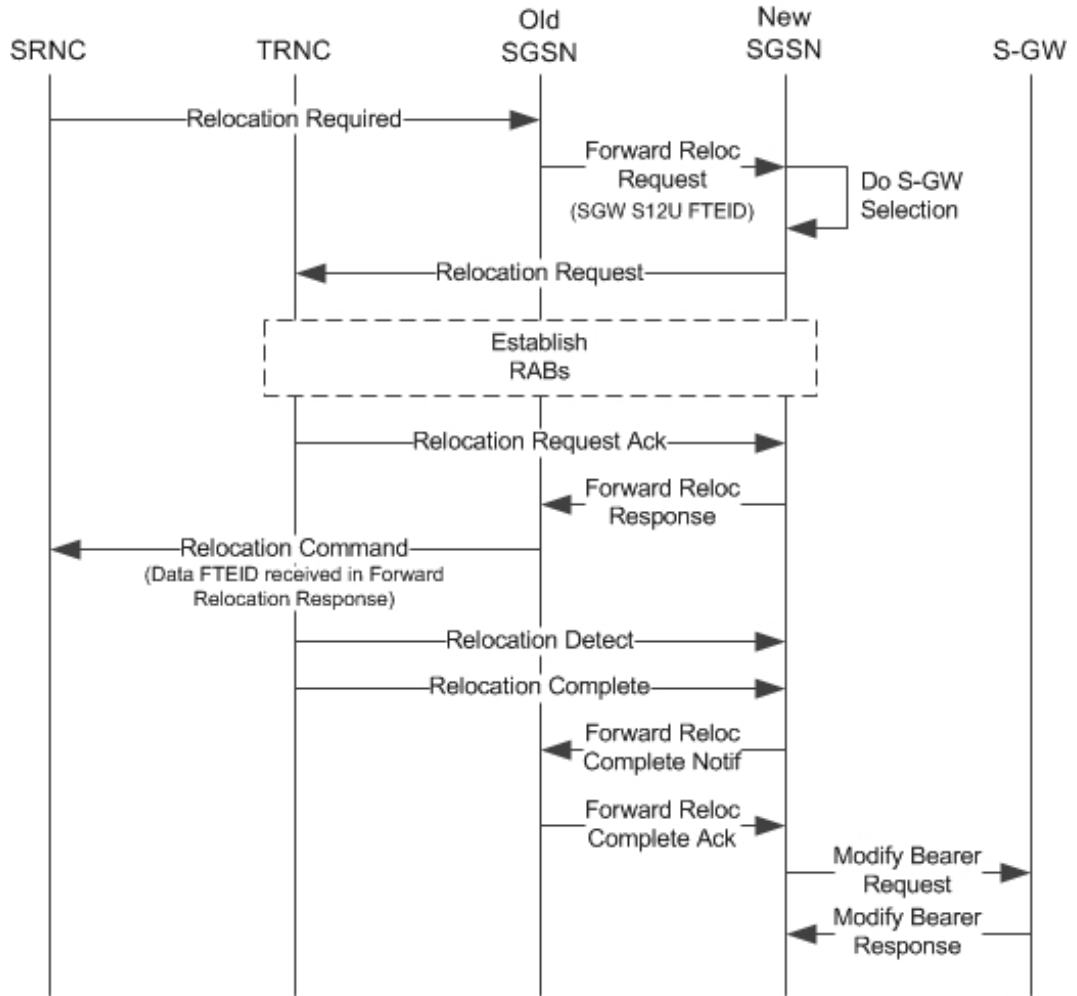

335805

The table below includes detailed behaviors for Old SRNS.

Old SRNS with Indirect Data Transfer

Indirect Data Transfer (IDFT) during Old SGSN SRNS happens during UTRAN-to-E-UTRAN connected mode IRAT handover. A Forward Relocation Request is sent with SGW S12U FTEID.

Figure 73: Old SRNS with Indirect Data Transfer 4

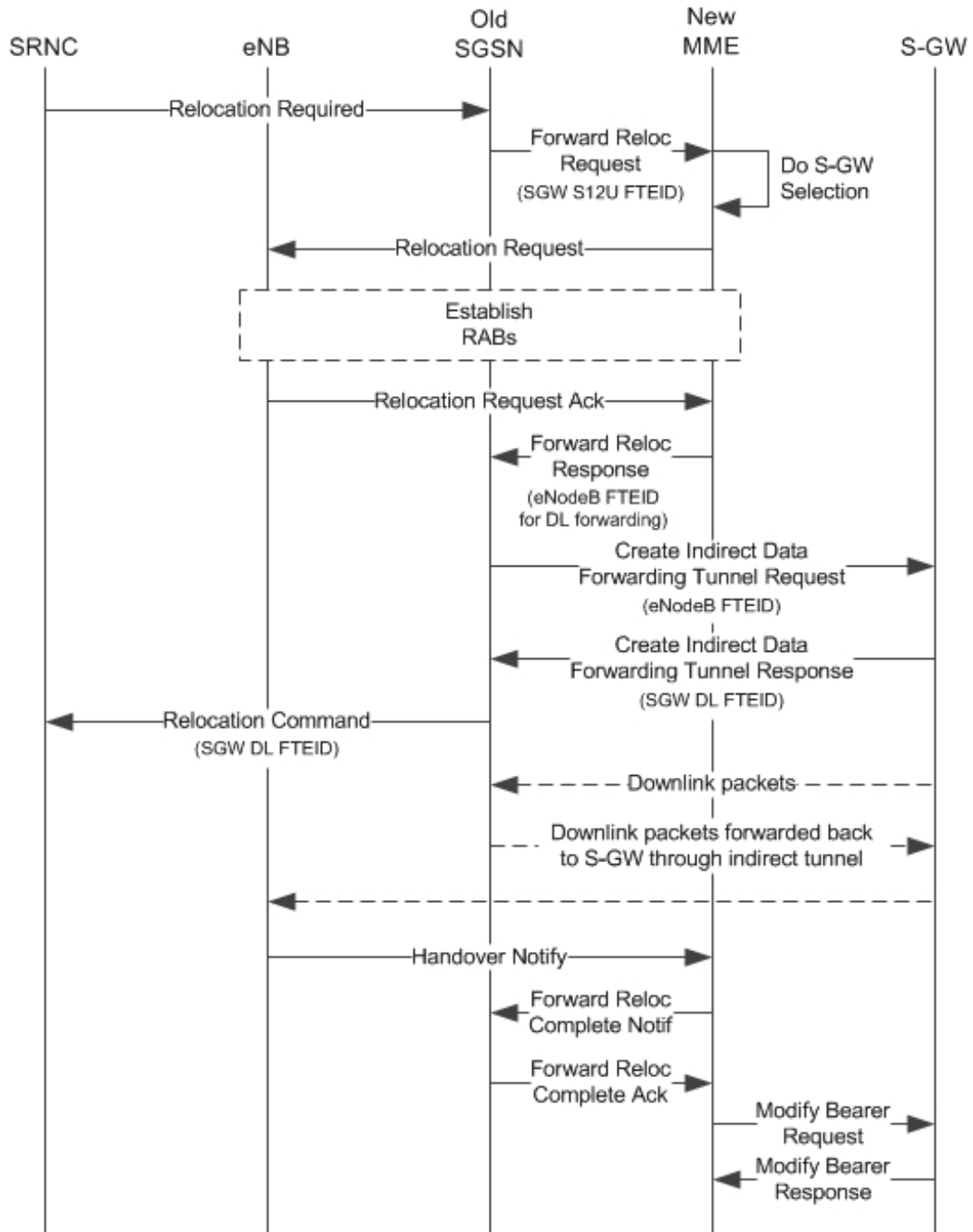

335806

Table 35: Old SRNS Behaviors

Source RNC DT Status	Direct Forwarding	S-GW Relocation	Behavior
Supported	No	No	Forward Relocation Request is send with SGW S12 U FTEID. If peer is MME, IDFT is applied. Then a Create Indirect Data Forwarding Tunnel Request is sent with User plane FTEID received in the Forward Relocation Response. This will be the eNB user plane FTEID. The SGW DL forwarding user plane FTEID received in the Create Indirect Data Forwarding Tunnel Response is sent in the Relocation Command.
Supported	Yes	No	Forward Relocation Request is sent with SGW S12 U FTEID. The eNB / RNC user plane FTEID received in the Forward Relocation Response is sent in the Relocation Command.
Supported	No	Yes	Forward Relocation Request is sent with SGW S12 U FTEID. If peer is MME, IDFT is applied. Then Create Indirect Data Forwarding Tunnel Request is sent with eNB User plane FTEID received in the Forward Relocation Response. The SGW DL forwarding user plane FTEID received in the Create Indirect Data Forwarding Tunnel Response is sent in the Relocation Command.
Supported	Yes	Yes	Forward Relocation Request is sent with SGW S12 U FTEID. The eNB / RNC use plane FTEID received in the Forward Relocation Response is sent in the Relocation Command.

Network Initiated Secondary PDP Context Activation

The S-GW sends a Create Bearer Request for Network Initiated Secondary PDP Context Activation with the SGW S12U FTEID. This FTEID is sent in a RAB Assignment Request to the RNC. The RNC S12U FTEID received in the RAB Assignment Response is sent to the S-GW in a Create Bearer Response.

Figure 74: Network Initiated Secondary PDP Context Activation 5

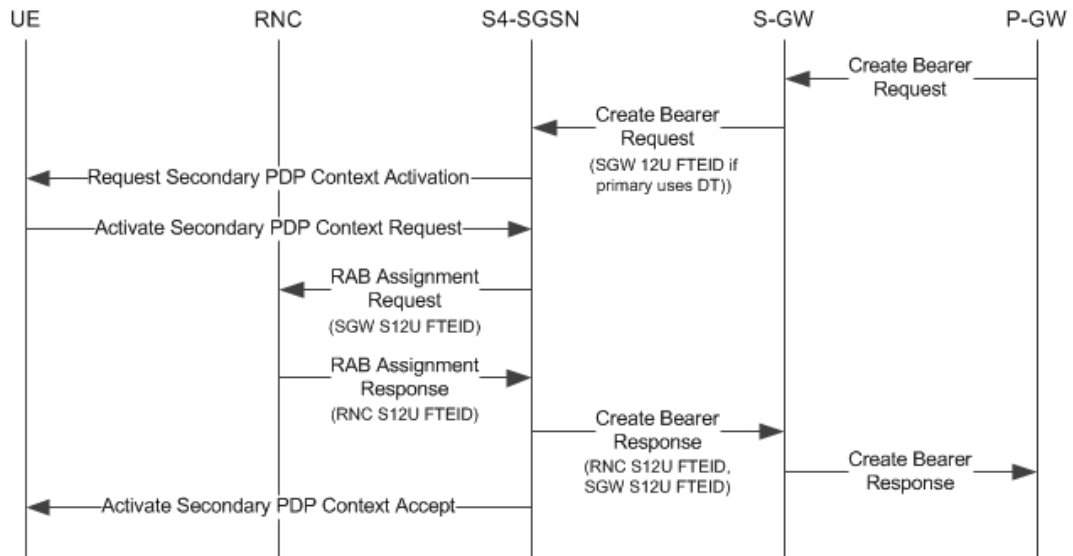

335807

PGW Init Modification when UE is Idle

If UE is in IDLE state and PGW Init Modification is received, the SGSN sends the first MBR. Upon getting PGW Init Modification in Idle State, the SGSN queues the PGW Init Modification and feeds a Downlink Data Notification internally. This sets up all RABs (using old QoS) and sends a Modify Bearer Request. When the Downlink Data Procedure is completed, the queued PGW Init Modification is processed.

Figure 75: PGW Init Modification when UE in Idle State

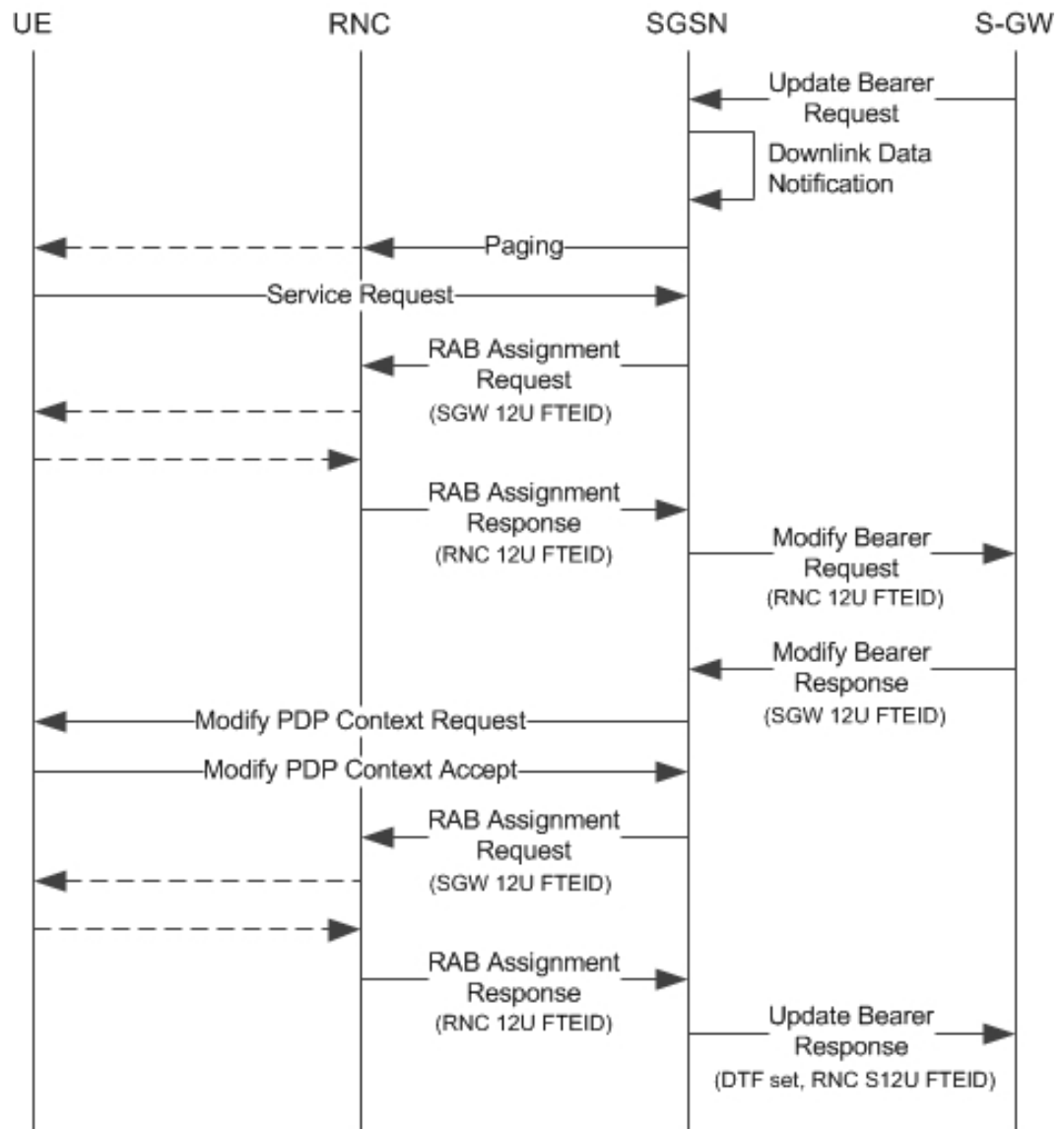

335808

Limitations

During an intra RAU, intra SRNS or Service Request triggered by RAB establishment, if a few RABs fail the Modify Bearer Request the SGSN will mark those RABs as bearers to be removed. Under current specifications, it is not possible to send a Modify Bearer Request with a few bearers having S12U U-FTEIDs and a few bearers not having U-FTEIDs.

There is an ongoing CR at 3GPP to allow such Modify Bearer Requests and the S-GW should send DDN when it gets downlink data for the bearers that did not have U-FTEIDs. If this CR is approved, the SGSN will support (in a future release) sending a partial set of bearers with S12U FTEID and some bearers without any U-FTEID.

Standards Compliance

The Direct Tunnel complies with the following standards:

- 3GPP TS 23.060 version 10 sec 9.2.2 General Packet Radio Service (GPRS) Service description
- 3GPP TS 29.274 v10.5.0 3GPP Evolved Packet System (EPS) Evolved General Packet Radio Service (GPRS) Tunnelling Protocol for Control plane (GTPv2-C)

Configuring Support for Direct Tunnel

The SGSN determines if setup of a direct tunnel is allowed or disallowed. Currently, the SGSN and S-GW are the only products that provide configuration commands for this feature. All other products that support direct tunnel do so by default.

By default, direct tunnel support is

- *disallowed* on the SGSN/S-GW
- *allowed* on the GGSN/P-GW

The SGSN/S-GW direct tunnel functionality is enabled within an operator policy configuration. One aspect of an operator policy is to allow or disallow the setup of direct GTP-U tunnels. If no operator policies are configured, the system looks at the settings in the operator policy named *default*. If direct tunnel is allowed in the *default* operator policy, then any incoming call that does not have an applicable operator policy configured will have direct tunnel *allowed*. For more information about the purpose and uses of operator policies, refer to the section *Operator Policy*.

Configuring Direct Tunnel on an S4-SGSN

Configuration of a GTP-U direct tunnel (DT) requires enabling DT both in a call control profile and for the RNC.



Important Direct tunneling must be enabled at both end points to allow direct tunneling for the MS/UE.

Enabling Setup of GTP-U Direct Tunnel

The SGSN determines whether a direct tunnel can be setup and by default the SGSN does not support direct tunnel. The following configuration enables a GTP-U DT in a call control profile:

```
config
  call-control-profile policy_name
    direct-tunnel attempt-when-permitted [ to-ggsn | to-sgw ]
  end
```

Notes:

- A call-control profile must have been previously created, configured, and associated with a previously created, configured, and valid operator policy. For information about operator policy creation/configuration, refer to the *Operator Policy* chapter in this guide.

- **to-ggsn** and **to-sgw** options are added to the **direct-tunnel** command to enable the operator to select the interface the SGSN will use for its direct tunnel. For a collocated Gn/GP-SGSN and an S4-SGSN,
 - Use the keyword **attempt-when-permitted** without a filter to enable both interface types: GTP-U towards the GGSN and S12 towards the SGW.
 - Use the keyword **attempt-when-permitted** with the **to-ggsn** keyword filter to enable only the GTP-U interface between the RNC and the GGSN.
 - Use the keyword **attempt-when-permitted** with the **to-sgw** keyword filter to enable only the S4's S12 interface between the RNC and the SGW.
- To remove the direct tunnel settings from the configuration, use the following command: **direct-tunnel attempt-when-permitted [to-ggsn | to-sgw]**
- Direct tunnel is allowed on the SGSN but will only setup if allowed on both the destination node and the RNC.

Enabling Direct Tunnel to RNCs

SGSN access to radio access controllers (RNCs) is configured in the IuPS service. Each IuPS service can include multiple RNC configurations that determine communications and features depending on the RNC. By default, DT functionality is enabled for all RNCs.

The following configuration sequence enables DT to a specific RNC that had been previously disabled for direct tunneling:

```
config
context ctxt_name
  iups-service service_name
    rnc id rnc_id
    default direct-tunnel
  end
```

Notes:

- An IuPS service must have been previously created, and configured.
- An RNC configuration must have been previously created within an IuPS service configuration.
- Command details for configuration can be found in the *Command Line Interface Reference*.

Restricting Direct Tunnels

The following configuration scenario prohibits the S4-SGSN to setup direct tunneling over the S12 interface during Inter SGSN RAUs:

```
config
call-control-profile profile_name
  rau-inter avoid-s12-direct-tunnel
end
```

Restrict direct tunneling by a specific RNC. The following configuration scenario restricts the SGSN from attempting to setup a direct tunnel when a call originates from a specific RNC.

```

config
  context context_name
    iups-service service_name
      rnc id rnc_id
        direct-tunnel not-permitted-by-rnc
      end
    end

```

Verifying the Call-Control Profile Configuration

Use the following command to display and verify the direct tunnel configuration for the call-control profiles:

```
show call-control-profile full name <profile_name>
```

The output of this command displays all of the configuration, including direct tunnel for the specified call-control profile.

```

Call Control Profile Name = ccprofile1
.
.
.
Re-Authentication
    : Disabled
Direct Tunnel
    : Not Restricted
GTPU Fast Path
    : Disabled
.
.

```

Verifying the RNC Configuration

Use the following command to display and verify the direct tunnel configuration in the RNC configuration:

```
show iups-service name <service_name>
```

The output of this command displays all of the configuration, including direct tunnel for the specified IuPS service.

```

IService name                               : iups1
.
.
.
Available RNC:
  Rnc-Id                                     : 1
  Direct Tunnel                             : Not Restricted

```

Configuring S12 Direct Tunnel Support on the S-GW

The example in this section configures an S12 interface supporting direct tunnel bypass of the S4 SGSN for inter-RAT handovers.

The direct tunnel capability on the S-GW is enabled by configuring an S12 interface. The S4 SGSN is then responsible for creating the direct tunnel by sending an FTEID in a control message to the S-GW over the S11 interfaces. The S-GW responds with its own U-FTEID providing the SGSN with the identification information required to set up the direct tunnel over the S12 interface.



Important If you modify the **interface-type** command, the parent service (service within which the eGTP/GTP-U service is configured) will automatically restart. Service restart results in dropping of active calls associated with the parent service.

Use the following example to configure this feature.

configure

```

context egress_context_name -noconfirm
  interface s12_interface_name
    ip address s12_ipv4_address_primary
    ip address s12_ipv4_address_secondary
  exit
exit
port ethernet slot_number/port_number
  no shutdown
  bind interface s12_interface_name egress_context_name
  exit
context egress_context_name -noconfirm
  gtpu-service s12_gtpu_egress_service_name
    bind ipv4-address s12_interface_ip_address
  exit
  egtp-service s12_egtp_egress_service_name
    interface-type interface-sgw-egress
    validation-mode default
    associate gtpu-service s12_gtpu_egress_service_name
    gtpc bind address s12_interface_ip_address
  exit
  sgw-service sgw_service_name -noconfirm
    associate egress-proto gtp egress-context egress_context_name
egtp-service s12_egtp_egress_service_name
  end

```

Notes:

- The S12 interface IP address(es) can also be specified as IPv6 addresses using the **ipv6 address** command.

Monitoring and Troubleshooting Direct Tunnel

show subscribers sgsn-only

The output of this command indicates whether Direct Tunnel has been established.

```
show subscribers sgsn-only full all
```

```

Username: 123456789012345
Access Type: sgsn-pdp-type-ipv4      Network Type: IP
Access Tech: WCDMA UTRAN
|
|

```

show gmm-sm statistics sm-only

```

NSAPI: 05                               Context Type: Primary
Context initiated by: MS
Direct Tunnel : Established

```

show gmm-sm statistics sm-only

The output of this command indicates the number of total active PDP contexts with direct tunnels.

show gmm-sm statistics sm-only

```

Activate PDP Contexts:
Total Actv PDP Ctx:
  3G-Actv Pdp Ctx:           1  2G-Avtv Pdp Ctx:       0
  Gn Interface:             1  Gn Interface:           0
  S4 Interface:             1  S4 Interface:           0
Total Actv Pdp Ctx:
  with Direct Tunnel:       1

```

Direct Tunnel Bulk Statistics

Currently there are no bulk statistics available to monitor the number of PDP contexts with Direct Tunnel.

Bulk statistics under the EGTPC schema are applicable for both Direct Tunnel and Idle Mode Signalling Reduction (ISR) [3G and 2G]. The following statistics track the release access bearer request and response messages which are sent by the SGSN to the S-GW upon Iu or RAB release when either a direct tunnel or ISR is active:

- tun-sent-relaccbearreq
- tun-sent-retransrelaccbearreq
- tun-recv-relaccbearresp
- tun-recv-relaccbearrespDiscard
- tun-recv-relaccbearrespaccept
- tun-recv-relaccbearrespdenied

The following bulkstats under EGTPC schema track Downlink Data Notification (DDN) Ack and failure messages between the S-GW and the SGSN when either direct tunnel or ISR is active:

- tun-recv-dlinknotif
- tun-recv-dlinknotifDiscard
- tun-recv-dlinknotifNorsp
- tun-recv-retransdlinknotif
- tun-sent-dlinknotifackaccept
- tun-sent-dlinknotifackdenied
- tun-sent-dlinkdatafail

For complete descriptions of these variables, see the EGTPC Schema Statistics chapter in the *Statistics and Counters Reference*.



CHAPTER 14

Dynamic Guaranteed Bit Rate

This chapter describes the following topics:

- [Feature Summary and Revision History, on page 343](#)
- [Feature Description, on page 344](#)
- [How It Works, on page 344](#)
- [Limitations and Restrictions, on page 345](#)
- [Configuring Dedicated GBR Bearer, on page 346](#)

Feature Summary and Revision History

Summary Data

Applicable Product(s) or Functional Area	<ul style="list-style-type: none">• P-GW• SAEGW
Applicable Platform(s)	<ul style="list-style-type: none">• ASR 5500• VPC-DI• VPC-SI
Feature Default	Disabled - Configuration Required
Related Changes in This Release	Not Applicable
Related Documentation	<ul style="list-style-type: none">• <i>Command Line Interface Reference</i>• <i>P-GW Administration Guide</i>• <i>SAEGW Administration Guide</i>

Revision History

Revision Details	Release
First introduced.	21.4

Feature Description

When a Guaranteed Bit Rate (GBR) dedicated bearer is used, the bandwidth of resources is reserved on the network. If the subscriber data flow is at lower bandwidth than the allocated values, then extra GBR is wasted on the network.

This feature adds flexibility where the Gateway periodically monitors the usage of the GBR on the bearer and depending on the usage. The Gateway steps-up or steps-down the allocated GBR accordingly.

How It Works

This section describes the working of Dynamic GBR functionality.

- Dedicated GBR Bearer is created using local policy configurations on a session setup or on certain call events.
- The SAEGW monitors the GBR after bearer creation for every interval of 30 seconds.
- After every interval, SAEGW verifies the average data-rate with the threshold value configured.
- In case, if the threshold breaches, then the GBR is stepped-up or stepped-down as per the configured value.
- SAEGW allows configuration of an upper and lower threshold of the GBR and also step-up or step-down value corresponding to the upper and lower threshold value.

Upper Threshold Breach

First Threshold Breach:

- Subscriber creates the dedicated bearer with QCI=qci1 with GBR as 1000 kbps with the upper threshold configured as 80%, that is, 800 kbps.
- Every 30 seconds the data-rate is evaluated. If the threshold limit is breached then SAEGW initiates the Update Bearer Request to upgrade the GBR value to step up by the configured percentage value.
- After 30 seconds if data-rate evaluated is more than 800 kbps, then the UBR is initiated to upgrade the GBR. The GBR is upgraded with the aggregate value of the initial configured GBR and the step-up configured percentage. For example, if the step-up increase is configured as 20% (200 kbps), then the Update Bearer Request is triggered with 1200 kbps.

Second Threshold Breach:

- As the GBR is increased to 1200 kbps, new upper threshold being monitored is 80% of 1200, that is, 960 kbps.
- On the next monitoring interval, if data-rate usage crosses 960 kbps, SAEGW again initiates the Update Bearer Request to upgrade the GBR values. These GBR values are upgraded to step-up by configured percentage value (20%). However, this 20% is of the base value, that is 1000, and not 1200 kbps. Hence, the increase is again by 200 kbps and the Update Bearer Request is 1400 kbps as the new GBR.



Important The step increase percentage is of the base(initial) value of the bearer and not the current negotiated value. The maximum value to which GBR can be stepped up is the configured MBR value.

Lower Threshold Breach

First Threshold Breach:

- Subscriber creates the dedicated bearer with QCI=qci1 with GBR as 1000 kbps with lower threshold is configured as 50%.
- Due to upper threshold breach, SAEGW has upgraded the GBR to 1400 kbps.
- When the usage on the bearer reduces below 700 kbps (50% of current GBR), SAEGW initiates the Update Bearer Request to downgrade the GBR. These GBR values are downgraded to step-down by configured value (say 20%), that is $1400 - 200 = 1200$ kbps.



Important The step decrease percentage is of the base (initial) value of the bearer and not the current negotiated value. The GBR value will not be stepped down below the initial negotiated value.

Second Threshold Breach:

- As the GBR is decreased to 1200 kbps, the data decreases further to breach the new 50% lower threshold. That is, 50% of $1200 = 600$ kbps.
- SAEGW initiates the Update Bearer Request to downgrade the GBR values to step down by configured value (20%). That is, $1200 - 200 = 1000$ kbps.

Limitations and Restrictions

This section provides limitations and restrictions of this feature.

- The SAEGW monitors the bearer bandwidth on every 30-seconds interval.
- If GBR usage exceeds a configurable percentage of a configured threshold, SAEGW initiates a bearer modification procedure. SAEGW initiates this procedure with a bearer QoS update using an upper bound configured value. eNB and UER adjust GBR accordingly.
- If GBR usage falls below a configurable percentage of a configured threshold, SAEGW initiates a bearer modification procedure. This bearer modification procedure is initiated with a Bearer QoS update using a lower bound configured value. eNB and UER adjust GBR accordingly.
- In case multiple rules are configured on the same bearer, then QoS is enforced from the current negotiated bearer values. The individual values under charging action corresponding to the ruledef are not honored if this feature is enabled on the bearer.

- For the monitored bearer, if the bit rate is modified or rule is deleted, then the base value of GBR is changed. This change in base value of GBR leads to change in the step-up or step-down values.
- Session recovery and ICSR are supported.
- The step-up and step-down values are calculated as per the base values of the GBR of the bearer and not the current GBR applied on the bearer.

Configuring Dedicated GBR Bearer

This section provides the configuration commands added for this feature.

In addition to this, the following new configurations must be enabled.

1. Lower bound GBR (in %) to determine which GBR value to step-down.
2. Upper bound GBR (in %) to determine which GBR value to step-up.
3. Step-up the threshold (in %).
4. Step-down the threshold (in %). This value must be less than step-up threshold.

trigger

New CLI keywords **bearer-creation** and **monitor-bearer-bandwidth** have been added to this CLI command. The keyword **bearer-creation** triggers for every new bearer created. The keyword **monitor-bearer-bandwidth** triggers whenever the bearer bandwidth is evaluated.

```
configure
  active-charging service <service_name>
    service scheme <service_scheme_name>
      [ no ] trigger { bearer-creation | flow-create | loc-update |
monitor-bearer-bandwidth | sess-setup }
    end
```

Notes:

This CLI is disabled by default.

- **no**: If previously configured, deletes the specified configuration.
- **bearer-creation**: Triggers for every new bearer.
- **flow-create**: Triggers for every new flow.
- **loc-update**: Triggers whenever location changes for the subscriber.
- **sess-setup**: Triggers at the session setup.
- **monitor-bearer-bandwidth**: Triggers whenever bearer bandwidth is evaluated.

committed-data-rate

This CLI command has been added under the ACS Trigger Condition configuration mode to configure the committed data rate of the current negotiated value.

```
configure
  active-charging service <service_name>
    trigger-condition <trigger_condn_name>
      [ no ] committed-data-rate { lower_threshold <value_in_percentage>
| upper_threshold <value_in_percentage> }
    end
```

Notes:

- **no**: Disables the committed data rate of the current negotiated value.
- **committed-data-rate**: Specifies the committed data rate of the current negotiated value.
- **lower threshold**: Configures the threshold as a percentage of the current negotiated value.
- **upper threshold**: Configures the threshold as a percentage of the current negotiated value.
- *value_in_percentage*: Specifies the percentage of initial configured committed-data-rate value. This is an integer value of 0 to 100.

step-up

This new CLI command has been added to the ACS Trigger Action Configuration mode to step up the value of committed data rate.

```
configure
  active-charging service <service_name>
    trigger-action <trigger_action_name>
      [ no ] step-up committed-data-rate <negotiated_value>
    end
```

Notes:

- **no**: If previously configured, deletes the specified configuration.
 - **step-up** : Steps up the value of committed data rate by the percentage defined in the *negotiated_value*.
 - **committed-data-rate**: Defines the committed data rate.
- negotiated_value*: Specifies the percentage of initial configured committed-data-rate value. This is an integer value of 0 through 100.

step-down

This new CLI command has been added to the ACS Trigger Action Configuration mode to step down the value of committed data rate.

```
configure
```

```

active-charging service <service_name>
  trigger-action <trigger_action_name>
    [ no ] step-down committed-data-rate <negotiated_value>
  end

```

Notes:

- **no:** If previously configured, deletes the specified configuration.
- **step-down:** Steps down the value of the committed data rate by the percentage defined in the *negotiated_value*.
- **committed-data-rate:** Defines the committed data rate.
negotiated_value: Specifies the percentage of initial configured committed-data-rate value. This is an integer value of 0 through 100.

Sample Configuration

This section lists the sample configuration of the CLI commands used in this feature.

```

config
  active-charging service ACS
  trigger-action ta1
    step-up committed-data-rate 20
  exit
  trigger-action ta2
    step-down committed-data-rate 30
  exit
  trigger-condition tc1
    qci = 1
    committed-data-rate upper-threshold 80
  exit
  trigger-condition tc2
    qci = 1
    committed-data-rate lower-threshold 50
  exit
  service-scheme schemel
    trigger monitor-bandwidth
      priority 1 trigger-condition tc1 trigger-action ta1
      priority 2 trigger-condition tc2 trigger-action ta2
    exit
  subs-class class1
    any-match = TRUE
  exit
  subscriber-base base1
    priority 1 subs-class class1 bind service-scheme schemel
  exit
exit

```



CHAPTER 15

Embed IMSI into Session Id

- [Feature Summary and Revision History, on page 349](#)
- [Feature Description, on page 350](#)
- [How It Works, on page 350](#)
- [Limitations, on page 350](#)
- [Configuring Diameter Accounting Interim Interval, on page 351](#)
- [Monitoring and Troubleshooting, on page 352](#)

Feature Summary and Revision History

Summary Data

Applicable Product(s) or Functional Area	<ul style="list-style-type: none">• GGSN• P-GW• SAEGW• S-GW
Applicable Platform(s)	<ul style="list-style-type: none">• ASR 5500• VPC - Di• VPC - Si
Feature Default	Disabled - Configuration Required
Related Changes in This Release	Not Applicable
Related Documentation	<ul style="list-style-type: none">• <i>Command Line Interface Reference</i>• <i>GGSN Administration Guide</i>• <i>P-GW Administration Guide</i>• <i>SAEGW Administration Guide</i>• <i>S-GW Administration Guide</i>

Revision History

Revision Details	Release
First introduced.	21.3

Feature Description

For troubleshooting and investigating network issues related to the Diameter interface, it is important to filter the subscriber or UE specific Diameter traffic. Any traffic associated with a particular IMSI can be easily filtered, even without knowing the Diameter session ID, if the IMSI information is embedded into the Diameter Session ID AVP. This feature allows the operator to filter the subscriber or UE specific Diameter traffic.

This feature introduces a new CLI command **session-id include imsi** under the **diameter endpoint configuration** mode to embed IMSI into Diameter session ID AVP over the Gx, Gy, and Gz (Rf) interface.



Important This feature is license controlled. Contact your Cisco account representative for information on how to obtain a license.

How It Works

A new CLI command **session-id include imsi** has been added under the **diameter endpoint configuration** mode to enable/disable inclusion of IMSI in Session-Id AVP for all Diameter sessions associated with that Diameter endpoint. Operators can enable only the required Diameter endpoints and control the inclusion of IMSI in the Session-ID AVP. IMSI information is included in the Diameter Session-ID AVP over the Gx, Gy, and Gz (Rf) interface, if the **session-id include imsi** is enabled on respective Diameter endpoints.

For emergency call with "only IMEI", IMSI information is not available for that emergency PDN. Hence, this IMSI information is not included in Diameter Session-ID at Gx, Gy, and Gz interface, when **session-id include imsi** is enabled. Configuring **session-id include imsi** impacts only new PDN connection and does not have any impact on existing PDN connection behavior (Gx, Gy, and Gz (Rf)) interface. For example, if the CLI command to include IMSI is enabled for the Gy Diameter endpoint after PDN creation. If a new dedicated bearer is created after this configuration change, then in this case Gy session established for a new dedicated bearer is not included IMSI in Gy Diameter session ID.

There is no impact of session manager recovery/ICSR on the session-ID AVP. Session-ID associated with Gx, Gy, and Gz (Rf) session is recovered transparently (which is irrespective of latest endpoint configuration). New sessions come up with session IDs as per the configuration on the newly active chassis.

Limitations

Following are the known limitations of this feature:

- Assuming IMSI information as sensitive information, operator must consider security aspects before enabling this CLI option.

- For an emergency call with "Only IMEI", IMSI information is not available for the emergency PDN, hence it is not included in the diameter Session-ID at Gx, Gy, and Gz (Rf) interface.
- During ICSR upgrade scenario, it is assumed that the new CLI option must be enabled only when the upgraded chassis is in stable state and there exists no chances of ICSR downgrade.
- If new CLI is enabled in the newer version of chassis, ICSR Downgrade is not recommended.
- As new CLI option is not available in old software versions, hence ICSR downgrade is not recommended. Performing ICSR downgrade should have the following impact on the diameter sessions, which have IMSI, included as part of Session-ID.
 - Gx and Gy: Existing diameter session (Gx, Gy) should be downgraded with old format of Session-Id. In that case, both P-GW and PCRF are out of sync leading to hanging session at P-GW or/and PCRF. Any communication from PCRF (RAR)/P-GW (CCR-U) can lead to stale session deletion.
 - Gz (Rf): However, Rf sessions should be recovered properly and any Rf signaling is sent out to Rf servers properly but responses cannot be processed as diamproxy cannot parse the new format session id which again puts Rf sessions into stale state until purged.

Configuring Diameter Accounting Interim Interval

The following CLI command has been added under the **diameter endpoint** configuration mode to include IMSI in Diameter session-ID per Diameter endpoint at Gx, Gy, and Gz (Rf). Configuration changes will be applicable only to new Sessions at Gx, Gy and Rf. Configuration changes will not have any impact on existing sessions behavior at Gx, Gy, and Rf. For Gy, multiple Diameter sessions can be initiated per subscriber and the session ID format setting will bind to the subscriber. The setting will be taken to effect when the first Diameter session is established and following Gy sub sessions will keep using the session ID format used in first session.

```

configure
  context context_name
    diameter endpoint endpoint_name
      [no] session-id include imsi
    end

```

Notes:

- **session-id:** Describes Diameter Session-ID format
- **include:** Includes configured information in Diameter Session-ID
- **imsi:** Includes International Mobile Subscriber Identification (IMSI) in Diameter Session-ID
- **no:** Disables this feature, that is, IMSI is not included in the Diameter Session-ID, which is the default behavior.
- By default, CLI is disabled, hence IMSI will not be populated in Diameter Session-ID.

Monitoring and Troubleshooting

The following sections describe commands available to monitor the feature.

Show Commands and Outputs

This section provides information regarding show commands and their outputs in support of the feature.

show configuration

The output of the above command is modified to display the following new field depending on whether the CLI is enabled or disabled:

- session-id include imsi
- no session-id include imsi

show configuration [verbose]

The output of the above command is modified to display the following new field depending on whether the CLI is enabled or disabled:

- session-id include imsi
- no session-id include imsi



CHAPTER 16

Enabling S6b for IMS APN

This chapter describes the following topics:

- [Feature Summary and Revision History](#), on page 353
- [Feature Changes](#), on page 354
- [Configuring Commands for Enabling S6b for IMS APN](#), on page 354
- [Enabling S6b Authentication for Trusted Wi-Fi](#), on page 355
- [Show Commands and Outputs](#), on page 356

Feature Summary and Revision History

Summary Data

Applicable Product(s) or Functional Area	<ul style="list-style-type: none">• GGSN• P-GW• SAEGW
Applicable Platform(s)	All
Feature Default	Disabled - Configuration Required
Related Changes in This Release	Not Applicable
Related Documentation	<ul style="list-style-type: none">• <i>Command Line Interface Reference</i>• <i>GGSN Administration Guide</i>• <i>P-GW Administration Guide</i>• <i>SAEGW Administration Guide</i>

Revision History



Important Revision history details are not provided for features introduced before releases 21.2 and N5.1.

Revision Details	Release
In this release, S2a authorization is enabled to separate the authentication request for LTE and Wi-Fi interfaces using <code>authorize-with-hss eGTP</code> configuration. It enables s6b authentication in both APN and P-GW service for S2a interface only.	21.21
With this feature, S6b authorization is enabled for 3G access at the APN level to allows P-GW to update the new P-GW ID to HSS.	21.6
First introduced.	Pre 21.2

Feature Changes

Currently, P-GW supports enabling S6b authentication for 3G access on GGSN service level configuration.

For LTE or Wi-Fi access, S6b authentication is supported on both P-GW service level and APN level configuration. If the S6b authentication is enabled for particular APN, when the subscriber joined on LTE transfers to Wi-Fi then 3G, UE does re-registration of the IMS session on 3G. Different P-GW is selected. However, SGSN does not update the new P-GW. HSS has the history of the old P-GW. When the subscriber transfers back to LTE and then to Wi-Fi, it hands over to the old P-GW. However, the old P-GW does not have the new IMS session and this result in the handover failure. With this feature, S6b authorization is enabled for 3G access at the APN level to let P-GW update the new P-GW ID to HSS. This addresses the inconsistency. Following two **authorize-with-hss** CLI keywords are added at the APN level to enable S6b authentication for 3G access and GnGp handover.

- **gn-gp-enabled**: Enables the S6b authentication for 3G access during the call connect and gn-gp handover.
- **gn-gp-disabled**: Terminates S6b connection when the subscriber moves to 3G access. This is used to override the legacy handover behavior where the session was continued irrespective of the configuration.



Note These new keywords are not configured by default when **authorize-with-hss** or **authorize-with-hss egtp** are configured. You have to explicitly enable this customized behavior by configuring the CLI commands introduced for this feature.

Enhancement to S6b Authentication: In StarOS 21.21 and later releases, S2a authorization is enabled to separate the authentication request for LTE and Wi-Fi interfaces using **authorize-with-hss egtp** configuration. It enables s6b authentication in both APN and P-GW service for S2a interface only.

Configuring Commands for Enabling S6b for IMS APN

S6b authentication can be enables at the APN level, two new keywords have been added to the **authorize-with-hss** CLI command.

To enable or disable S6b, execute the following command:

```
configure
```

```

context context_name
  apn apn_name
    authorize-with-hss [ egtp [ gn-gp-enabled ] [ s2b [ gn-gp-enabled
[ report-ipv6-addr ] ] ] [ s5-s8 [ gn-gp-disabled | gn-gp-enabled ] ] [
report-ipv6-addr ] | lma [ s6b-aaa-group aaa-group-name | report-ipv6-addr
] | report-ipv6-addr ]
      [ default | no ] authorize-with-hss
    exit

```

NOTES:

- **gn-gp-disabled:** Disables S6b authorization for 3G initial attach and GNGP handover.
- **gn-gp-enabled:** Enables S6b authorization for 3G initial attach and GNGP handover.
- **s2b:** Enable S6b authorization for egtp-S2b.
- **s5-s8:** Enable S6b authorization for egtp-S5S8.
- **report-ipv6-addr:** Enables IPv6 reporting through AAR toward the S6b interface.

Enabling S6b Authentication for Trusted Wi-Fi

Enabling S6b Authentication for Trusted Wi-Fi

S6b authentication is enabled for all LTE and Wi-Fi interface using HSS authentication process. To separate this authentication request for LTE and Wi-Fi interfaces a new configuration is introduced. The parameter S2a is added to represent the trusted Wi-Fi interface in the configuration part of **authorize-with-hss egtp** and this enables the S6b authentication for S2A interface only and this is done in both APN and P-GW service configuration.

Use the following S2a configuration command to indicate Trusted Wi-Fi at authorize-with-hss egtp:

```

configure
context context_name
  apn apn_name | pgw-service service_name
    authorize-with-hss [ egtp [s2a [gn-gp-enabled [report-ipv6-addr]
] ] ]
      [ default | no ] authorize-with-hss
    exit

```



Note Enabling the S6b authentication is allowed with a combination of S2a and S2b, or S2a and S5-S8, or S2b and S5-S8.

Below are the examples to enable the s6b authentication for S2a interface alone in APN and P-GW Service.

Example for APN Service

```

apn intershat
  pdp-type ipv4 ipv6
  bearer-control-mode mixed
  selection-mode subscribed sent-by-ms chosen-by-sgsn

```

```

authorize-with-hss egtp s2a
ims-auth-service ims-ggsn-auth
ip access-group acl4-1 in
ip access-group acl4-1 out
ip context-name egress
ipv6 access-group acl6-1 in
ipv6 access-group acl6-1 out
active-charging rulebase prepaid
exit

```

Example for P-GW Service

```

pgw-service pgw_service
authorize-with-hss egtp s2a
associate ggsn-service ggsn-service
associate egtp-service egtp_service
associate peer-map map_pgw
egtp create-session-rsp apn-ambr-always-include
exit

```

Show Commands and Outputs

This section provides information regarding show commands and their outputs in support of the feature.

show apn name

This CLI command is modified to include the gn-gp enabled or disabled status:

- Authorization with S6b : HSS-EGTP-S5S8 GN-GP-Disabled
- Authorization with S6b : HSS-EGTP-S5S8 GN-GP-Enabled

show config apn intershat

The following new fields are added to the show command to indicate the gn-gp enabled or disabled status:

- authorize-with-hss egtp s5-s8 gn-gp-enabled
- authorize-with-hss egtp s5-s8 gn-gp-disabled



CHAPTER 17

Expanded Prioritization for VoLTE/Emergency Calls

This chapter describes the StarOS support for the Expanded Prioritization for VoLTE/Emergency Calls feature on the P-GW, SAE-GW, and S-GW.

- [Feature Description, on page 357](#)
- [How It Works, on page 359](#)
- [Configuring Expanded Prioritization for VoLTE/Emergency Calls, on page 360](#)
- [Monitoring and Troubleshooting the Expanded Prioritization for VoLTE/Emergency Calls, on page 362](#)

Feature Description

The National Security/Emergency Preparedness (NS/EP) Next Generation Network (NGN) Priority Services (NGN-PS) (formerly called NGN Government Emergency Telecommunications Service (GETS)) is a set of voice, video and data services that are based on services available from public packet-switched Service Providers. The NS/EP NGN-PS provides priority treatment for a Service User's NS/EP communications and is particularly needed when the Service Providers' networks are impaired due to congestion and/or damage from natural disasters (such as floods, earthquakes and hurricanes) and man-made disasters (such as physical, cyber or other forms of terrorist attacks).

The DSCP marking of control message from P-GW and S-GW was based on associated egtpc-service configuration.

For control message belonging to eMPS session or containing Allocation and Retention Priority (ARP) associated with eMPS profile, the DSCP marking is based on eMPS profile configured DSCP value.

As part of this enhancement, support is also added for marking of certain GTP-C message at the P-GW and S-GW for priority treatment as defined in the Government Industry Requirements (GIR) NS/EP NGN.

Relationships to Other Features

Bulkstats for GTP-C Messages by ARP Value: The S-GW/P-GW will generate peg counts of the total number of received GTP-C messages containing an ARP, chosen from the set of values allocated for NS/EP NGN-PS use, for a specified interval (in minutes). This peg count is administered at the S-GW/P-GW level.

To prevent throttling of GTP-C messages corresponding to eMPS PDNs or messages containing ARP from set of configured ARP(PL) reserved for NS/EP NGN priority service, following configuration are to be considered:

1. Load Overload control

In overload control profile, the set of ARPs reserved for NS/EP NGN-PS use for eMPS services should also be defined under **throttling-behavior exclude** and **self-protection-behavior exclude** CLI commands. This will ensure that incoming GTP-C messages for eMPS PDN or containing ARP from set of reserved ARP for eMPS use are not throttled. Example of configuring Load Overload configuration:

```
configure
  gtpc-overload-control-profile profile_name
    throttling-behavior { earp { 1...15 } * } { exclude }
    self-protection-behavior { earp { 1...15 } * } { exclude }
  end
```

2. For Prioritized handling of calls under Congestion condition

ARP reserved under NS/EP NGN-PS for eMPS services is recommended to be configured under following congestion control CLI command. This will ensure that new call requests are not throttled during congestion condition defined by the **congestion-control** CLI command at context level:

```
configure
  context context_name
    egtp-service service_name
      gtpc allow-on-congestion arp arp_value
    end
```

3. GTP-C RLF Throttling

- If GTP-C RLF Throttling feature is enabled, then **gtpc overload-protection egress throttling-override-policy** CLI command should be configured with ARP(PL), reserved for NS/EP NGN-PS use, for eMPS services to bypass RLF throttling.
- If GTP-C RLF Throttling for incoming messages is configured using **gtpc overload-protection ingress msg-rate *message_rate*** CLI command, then eMPS related messages can get throttled. Currently, there is no bypass policy for incoming RLF throttling.



Important

Any existing features which works on ARP (PL) configurations will continue to work as before irrespective of whether ARP values configured are same as reserved under NS/EP NGN-PS for eMPS services. If existing features need to work with eMPS requirements, then same ARP (PL) values should be configured as reserved NS/EP NGN-PS for eMPS services.

Licensing

The DSCP marking capability requires that a valid license key be installed. Contact your Cisco Account or Support representative for information on how to obtain a license.

How It Works

GIR Document References

The following table describes the requirements of this feature as per the GIR document.

Requirement No.	Description
R-127	[202] The S-GW shall transmit with priority a GTP-C “Downlink Data Notification” message or a GTP-C “Create Bearer Request” message or a GTP-C “Update Bearer Request” message, any of which contains an ARP chosen from the set allocated by the Service Provider for use by NS/EP NGN-PS.
R-130	[204] The S-GW shall mark for priority treatment the S11 “Create Session Response” message from the S-GW to the MME which contains request to establish a bearer or bearers with an ARP corresponding to an NS/EP NGN-PS call/session.
R-132	[205] The S-GW shall mark for priority treatment the S11 “Create Bearer Request” and S11 “Update Bearer Request” messages from the SGW to the MME which contains an indication that a UE currently has an established/updated bearer or bearers for NS/EP NGN-PS service.
R-134	[206] In the case where the S5/S8 Interface is GTP-based, the S-GW shall mark for priority treatment the S5/S8 “Create Session Request” message from the S-GW to the PDN-GW which contains an indication that a UE will establish a bearer or bearers for NS/EP NGN-PS.
R-137	[207] In the case where the S5/S8 Interface is GTP-based, the S-GW shall mark for priority treatment the S5/S8 “Create Bearer Response” and “Update Bearer Response” messages from the S-GW to the PDN-GW which contain an indication that a UE currently has established / updated a bearer or bearers for NS/EP NGN-PS.
R-143	[213] In the case where the S5/S8 Interface is GTP-based, the PDN-GW shall mark for priority treatment the S5/S8 “Create Session Response” message from the PDN-GW to the S-GW which contains a request to establish a bearer or bearers with an ARP corresponding to an NS/EP NGN-PS call/session.
R-146	[216] In the case where the S5/S8 Interface is GTP- based, the PDN-GW shall mark for priority treatment the S5/S8 “Create Bearer Request” and “Update Bearer Request” messages from the PDN-GW to the S-GW which contain an indication that a UE currently has an established/updated bearer or bearers for NS/EP NGN-PS.

Configuring Expanded Prioritization for VoLTE/Emergency Calls

The following section provides the configuration commands to enable the feature.

Configuring eMPS Profile and its Associated Attributes

At Configuration Mode level, CLI command option is introduced to define an eMPS profile and its associated attributes like:

- **eARP configuration:** This configuration is used for marking a bearer/PDN as an eMPS.
- **DSCP configuration:** This configuration is used at S-GW/P-GW to mark various outgoing GTP-C messages associated with an eMPS PDN with configured DSCP marking.

```
configure
[ no ] emps-profile emps_profile_name -noconfirm
[ no ] earp { [ 1...15 ] { [ 1...15 ] { [ 1...15 ] } } }
[ no ] dscp-marking dscp_value
end
```

Notes:

- **emps-profile** *emps_profile_name*: Configures eMPS profile for defining attributes of an eMPS session. The *emps_profile_name* is a string of size from 1 to 63.
- **earp**: Configures a maximum of 3 eARP priority level (PL) values so that sessions with configured eARP priority values can be marked as eMPS sessions.
- **-noconfirm**: Creates a new eMPS profile without prompting for confirmation.
- **dscp-marking** *dscp_value*: Specifies the DSCP value to be applied to eMPS sessions. The *dscp_value* is a hexadecimal number between 0x0 and 0x3F.
- Maximum of 3 eARP values can be configured under an eMPS profile. The above CLI syntax provides flexibility to configure one or more (max 3) eARP values in a single command. For example:

```
earp 1 2 3
```

-Or-

```
earp 4
```
- The latest set of eARP values configured will overwrite the previous configuration. For example: Invoking below two commands in sequence will configure only eARP value 4.

```
earp 1 2 3
```

```
earp 4
```
- eMPS profile name should be unique and is treated case insensitive across context.
- The **no earp** command can be used to disable all configured eARP values. However, this will not delete the corresponding eMPS profile. The **no emps-profile** *emps_profile_name* CLI command will delete the profile.

- Warning message: When **no** of a non-existent eMPS profile is executed, a warning message is displayed. For example:

```
no emps-profile xyz
eMPS Profile : xyz does not exist
```

There will be no warning message if **no** of an un-configured eARP is executed.

- There will be a warning and confirmation message when existing profile is deleted:

```
This operation will result in deletion of this eMPS Profile.
Are you sure? [Yes|No]:
```

- Maximum of 64 different eMPS profiles can be configured.

Associating an eMPS Profile with P-GW Service

The commands illustrated below associates an eMPS profile to P-GW service.

```
configure
context context_name
  pgw-service service_name
    associate emps-profile emps_profile_name
  end
```

Notes:

- **no associate emps-profile**: Disables the feature.
- **emps-profile** *emps_profile_name*: Associates an eMPS profile with the P-GW service. The *emps_profile_name* is a string of size 1 to 63.
- The eMPS profile name in input is treated as case insensitive.
- By default, no eMPS profile is associated with pgw-service.
- For SAE-GW associated P-GW service, the eMPS profiles should be same as configured in associated S-GW service. In case of any discrepancy, it will be reported in the **show configuration error** CLI command output.

Associating an eMPS Profile with S-GW Service

The commands illustrated below associates an eMPS profile to S-GW service.

```
configure
context context_name
  sgw-service service_name
    associate emps-profile emps_profile_name
  end
```

Notes:

- **no associate emps-profile**: Disables the feature.
- **emps-profile** *emps_profile_name*: Associates an eMPS profile with the S-GW service. The *emps_profile_name* is a string of size 1 to 63.

- The eMPS profile name in input is treated as case insensitive.
- By default, no eMPS profile is associated with sgw-service.
- For SAE-GW associated S-GW service, the eMPS profiles should be same as configured in associated P-GW service. In case of any discrepancy, it will be reported in the **show configuration error** CLI command output.

Monitoring and Troubleshooting the Expanded Prioritization for VoLTE/Emergency Calls

This section provides information regarding show commands and/or their outputs in support of this enhancement.

Show Command(s) and/or Outputs

show emps-profile { all | name <emps_profile_name> }

The above CLI command is introduced to see a particular or all eMPS profile(s) configured with its associated attributes. Also, the output of an existing **show config [verbose]** CLI command is modified to reflect an eMPS configuration:

- **earp configured:** <earp_value>
- **dscp-marking configured:** <dscp-value>

These CLI commands can be used to verify if the configuration is appropriate.

show pgw-service { name <name> | all }

The output of this command is modified to reflect the eMPS profile associated with the P-GW service:

- **eMPS Profile Name :** <emps_profile_name>



Important Maximum of one eMPS profile can be associated with P-GW service at a time; the latest configuration will overwrite the previously associated configuration.

show sgw-service { name <name> | all }

The output of this command is modified to reflect the eMPS profile associated with the S-GW service:

- **eMPS Profile Name :** <emps_profile_name>



Important Maximum of one eMPS profile can be associated with S-GW service at a time; the latest configuration will overwrite the previously associated configuration.

show subscribers pgw-only full all

The output of this command is modified to reflect whether the session is eMPS or not. For example:

```
Username: 0123456789@username
Subscriber Type   : Visitor
Status           : Online/Active
State            : Connected
Connect Time     : Wed Sep  7 07:02:49 2016
Auto Delete      : No
Idle time        : 00h00m08s
MS TimeZone      : n/a
Access Type: gtp-pdn-type-ipv4
Access Tech: eUTRAN
Callid: 00004e21
MSISDN: 0123456789
Interface Type: S5S8GTP
TWAN Mode: N/A
Daylight Saving Time: n/a
Network Type: IP
pgw-service-name: pgw_service
IMSI: 123456789012341
Low Access Priority: N/A
eMPS Bearer: Yes
Emergency Bearer Type: N/A
IMS-media Bearer: No
```

show subscribers saegw-only full all

The output of this command is modified to reflect whether the session is eMPS or not. For example:

```
Username: 0123456789@username
SAEGW Call mode  : Co-located
Subscriber Type   : Home
.
.
.
MSISDN: 0123456789
TWAN Mode: N/A
eMPS Bearer: Yes
MS TimeZone      :
MEI               : 1122334455667788
Daylight Saving Time: n/a
Accounting mode   : GTPP
```

show pgw-service statistics

The output of this command is modified to display the eMPS PDN statistics information. For example:

```
PDNs By Emergency-Type:
Emergency PDNs:
Active:          0      Setup:          0
Authentic IMSI:  0      Authentic IMSI:  0
.
.
.
eMPS PDNs:
Current Active:          1      Cumulative Activated:    1
Cumulative De-activated:  1
IPv4v6 PDN-Type Received with DAF False :          0
```

Where:

- **Current Active:** Increments when any PDN is setup as an eMPS PDN or upgraded to eMPS PDN. Decrements when an eMPS PDN is released or when it degrades to a non-eMPS PDN.
- **Cumulative Activated:** Increments when any PDN is setup as an eMPS PDN or upgrades to an eMPS PDN.

- **Cumulative De-activated:** Increments when an eMPS PDN is released or when it degrades to a non-eMPS PDN.

show saegw-service statistics all function pgw

The output of this command is modified to display the eMPS PDN statistics information. For example:

```
PDNs By Emergency-Type:
Emergency PDNs:
  Active:                0      Setup:                0
  Authentic IMSI:       0      Authentic IMSI:   0
.
.
.
eMPS PDNs:
  Current Active:                1      Cumulative Activated:    1
  Cumulative De-activated:       1
IPv4v6 PDN-Type Received with DAF False :      0
```

Where:

- **Current Active:** Increments when any PDN is setup as an eMPS PDN or upgraded to eMPS PDN. Decrements when an eMPS PDN is released or when it degrades to a non-eMPS PDN.
- **Cumulative Activated:** Increments when any PDN is setup as an eMPS PDN or upgrades to an eMPS PDN.
- **Cumulative De-activated:** Increments when an eMPS PDN is released or when it degrades to a non-eMPS PDN.

show saegw-service statistics

The output of this command is modified to display the eMPS statistics for PGW-Anchored/SGW-Anchored PDNs associated with the saegw-service. For example:

```
PDNs By Emergency-Type:
Emergency PDNs:
  Active:                0      Setup:                0
  Released:              0
.
.
.
eMPS PDNs:
Colocated PDNs:
  Current Active:                1      Cumulative Activated:    1
  Cumulative De-activated:       0
PGW-Anchor PDNs:
  Current Active:                1      Cumulative Activated:    1
  Cumulative De-activated:       0
SGW-Anchor PDNs:
  Current Active:                1      Cumulative Activated:    1
  Cumulative De-activated:       0
```

The above statistics information are further classified based on SAE-GW call types:

- **Colocated eMPS PDNs:** It reflects the eMPS PDN statistics information for collapsed PDNs.
- **PGW-Anchor eMPS PDNs:** It reflects the eMPS PDN statistics information for PGW-Anchor PDNs.

- **SGW-Anchor eMPS PDNs:** It reflects the eMPS PDN statistics information for SGW-Anchor PDNs.

Where:

- **Current Active:** Increments when any PDN is setup as an eMPS PDN or upgraded to eMPS PDN. Decrements when an eMPS PDN is released or when it degrades to a non-eMPS PDN.
- **Cumulative Activated:** Increments when any PDN is setup as an eMPS PDN or upgrades to an eMPS PDN.
- **Cumulative De-activated:** Increments when an eMPS PDN is released or when it degrades to a non-eMPS PDN.

show sgw-service statistics all

The output of this command is modified to reflect whether the session is eMPS or not. For example:

```
Subscribers Total:
  Active:           0   Setup:           2
  Released:         1
  .
  .
  .
eMPS PDN Statistics:
Current Active:           1   Cumulative Activated:   1
Cumulative De-activated:   0
```

show saegw-service statistics all function sgw

The output of this command is modified to display the eMPS PDN statistics information. For example:

```
Subscribers Total:
  Active:           0   Setup:           0
  Released:         0
  .
  .
  .
eMPS PDN Statistics:
Current Active:           1   Cumulative Activated:   1
Cumulative De-activated:   0
```

show configuration error

System will show configuration errors for following scenarios:

- When different eMPS profiles are configured under pgw-service and sgw-service associated to same sae-gw service. For example:

```
#####
      Displaying SAEGW-Service system errors
#####
Error   : eMPS profile of SGW <sgw-service> and PGW service <pgw_service>
is not same for SAEGW service <saegw-service> in the context <context_name>.
Total 1 error(s) in this section !
```

- When non-existent emps-profile is associated to pgw-service. For example:

```
#####
      Displaying PGW-Service system errors
#####
```

```
Error   : eMPS Profile <emps_profile_pgw> configured for PGW service <pgw_service>
is not present in the system
Total 1 error(s) in this section !
```

- When non-existent emps-profile is associated to sgw-service. For example:

```
#####
      Displaying SGW-Service system errors
#####
Error   : eMPS Profile <emps_profile_sgw> configured for SGW service <sgw_service>
is not present in the system
Total 1 error(s) in this section !
```

Bulkstats for Expanded Prioritization for VoLTE/Emergency Calls

PGW Schema

The following bulk statistics have been added to the P-GW schema as part of this enhancement:

- `sessstat-pdn-emps-current-active` – The total number of currently active P-GW eMPS PDNs.
- `sessstat-pdn-emps-cumulative-activated` – The total number of P-GW PDNs that are either setup as an eMPS PDN or upgrades to an eMPS PDN.
- `sessstat-pdn-emps-cumulative-deactivated` – The total number of P-GW PDNs that were either released or degrades to a non-eMPS PDN.

SGW Schema

The following bulk statistics have been added to the S-GW schema as part of this enhancement:

- `sessstat-pdn-emps-current-active` – The total number of currently active S-GW eMPS PDNs.
- `sessstat-pdn-emps-cumulative-activated` – The total number of S-GW PDNs that are either setup as an eMPS PDN or upgrades to an eMPS PDN.
- `sessstat-pdn-emps-cumulative-deactivated` – The total number of S-GW PDNs that were either released or degrades to a non-eMPS PDN.

SAEGW Schema

The following bulk statistics have been added to the SAE-GW schema as part of this enhancement:

- `pgw-anchor-pdns-emps-current-active` – The total number of currently active P-GW anchored eMPS PDNs.
- `pgw-anchor-pdns-emps-cumulative-activated` – The total number of P-GW anchored PDNs that are either setup as an eMPS PDN or upgrades to an eMPS PDN.
- `pgw-anchor-pdns-emps-cumulative-deactivated` – The total number of P-GW anchored PDNs that were either released or degrades to a non-eMPS PDN.
- `saegw-colocated-pdns-emps-current-active` – The total number of currently active SAE-GW collapsed eMPS PDNs.
- `saegw-colocated-pdns-emps-cumulative-activated` – The total number of SAE-GW collapsed PDNs that are either setup as an eMPS PDN or upgrades to an eMPS PDN.

- saegw-colocated-pdns-emps-cumulative-deactivated – The total number of SAE-GW collapsed PDNs that were either released or degrades to a non-eMPS PDN.
- sgw-anchor-pdns-emps-current-active – The total number of currently active S-GW anchored eMPS PDNs.
- sgw-anchor-pdns-emps-cumulative-activated – The total number of S-GW anchored PDNs that are either setup as an eMPS PDN or upgrades to an eMPS PDN.
- sgw-anchor-pdns-emps-cumulative-deactivated – The total number of S-GW anchored PDNs that were either released or degrades to a non-eMPS PDN.



CHAPTER 18

Extended QCI Options

This chapter describes extended QCI functionality.

- [Per QCI Packet Drop Counters and ARP Granularity for QCI Level Counters, on page 369](#)
- [DSCP Marking Based on Both QCI and ARP Values, on page 382](#)
- [New Standard QCI Support, on page 385](#)
- [Non-standard QCI Support, on page 422](#)

Per QCI Packet Drop Counters and ARP Granularity for QCI Level Counters

This section describes the Per QCI Packet Drop Counters and ARP Granularity for QCI Level Counters feature.

Feature Description

This section describes the Per QCI Packet Drop Counters and ARP Granularity for QCI Level Counters feature.

Support for QCI and ARP Visibility

As of StarOS release 20.2, the software has been enhanced to support the viewing of QoS statistics on a Quality of Service Class Index (QCI) and Allocation and Retention Priority (ARP) basis.

ARP is a 3GPP mechanism for dropping or downgrading lower-priority bearers in situations where the network becomes congested. The network looks at the ARP when determining if new dedicated bearers can be established through the radio base station. QCI is an operator provisioned value that controls bearer level packet forwarding treatments.

This enhancement enables operators to monitor QoS statistics that identify multiple services running with the same QCI value. In addition, packet drop counters have been introduced to provide the specific reason the Enhanced Charging Service (ECS) dropped a packet. The packet drop counters provide output on a per ARP basis. This provides additional information that operators can use to troubleshoot and identify network issues that may be affecting service.



Important For the ARP value only the priority level value in the Allocation/Retention Priority (ARP) Information Element (IE) is considered. Pre-emption Vulnerability (PVI) and Pre-emption Capability (PCI) flags in the ARP IE are not considered.

The existing **show apn statistics name** *apn-name* and **show apn statistics Exec Mode** CLI commands have been enhanced. The output of these commands now provides visibility for QoS statistics on a QCI/ARP basis.

Licensing



Important ARP Granularity for QCI Level Counters is a license-controlled feature. Per QCI Packet Drop Counters functionality does not require a license. Contact your Cisco account or support representative for licensing details.

Configuring ARP Granularity for QCI Level Counters

This section describes how to configure the ARP Granularity for QCI Level Counters feature.



Important ARP Granularity for QCI Level Counters is a license-controlled feature. Per QCI Packet Drop Counters functionality does not require a license. Contact your Cisco account or support representative for licensing details.

Configuring the feature consists of the following tasks:

1. Create a Stats Profile.
2. Enable the Collection of Per QCI Packet Drop Counters.
3. Enable the Collection of QCI/ARP Level Statistics.
4. Associate a Stats Profile with an APN.
5. Verify the Configuration.

Create a Stats Profile

Use the following example to access *Global Configuration Mode* and create a Stats Profile:

```
configure
stats-profile stats_profile_name
end
```

Notes:

- *stats_profile_name* must be an alphanumeric string from 1 to 63 characters in length.

Enable the Collection of Packet Drop Statistics

Use the following example to access *Stats Profile Configuration Mode* and create a Stats Profile and enable the collection of packet drop statistics:

```
configure
stats-profile stats_profile_name
packet-drop
end
```

To disable the collection of packet drop statistics

```
configure
stats-profile stats_profile_name
no packet-drop
end
```

Notes:

- *stats_profile_name* must be the name of an existing Stats Profile. The name must be an alphanumeric string from 1 to 63 characters in length.
- **packet-drop**: enables the collection of packet drop statistics for the specified Stats Profile.
- **no packet-drop**: disables the collection of packet drop statistics for the specified Stats Profile.

Enable the Collection of QCI/ARP Level Statistics

Use the following example to access *Stats Profile Configuration Mode* and enable the collection of QCI/ARP level statistics for a Stats Profile:

```
configure
stats-profile stats_profile_name
qci { all | 1 | 2 | 3 | 4 | 5 | 6 | 7 | 8 | 9 | [ non-std { non-gbr
| gbr } ] } { arp { all | [ 1 | 2 | 3 | 4 | 5 | 6 | 7 | 8 | 9 | 10 | 11
| 12 | 13 | 14 | 15 ] + } }
end
```

To disable the collection of QCI/ARP statistics:

```
configure
stats-profile stats_profile_name
no qci { all | 1 | 2 | 3 | 4 | 5 | 6 | 7 | 8 | 9 | [ non-std { non-gbr
| gbr } ] } { arp { all | [ 1 | 2 | 3 | 4 | 5 | 6 | 7 | 8 | 9 | 10 | 11
| 12 | 13 | 14 | 15 ] + } }
end
```

Notes:

- *stats_profile_name* must be the name of an existing Stats Profile. The name must be an alphanumeric string from 1 to 64 characters in length.
- **qci**: configures the collection of ARP priority level statistics for the specified QCI(s).
- **non-std**: configures the collection of ARP priority level statistics for non-standard QCIs.
- **non-gbr**: configures the collection of ARP priority level statistics for non-standard non-guaranteed bit rate (GBR) QCIs.

- **gbr**: configures the collection of ARP priority level statistics for non-standard GBR QCIs.
- **arp**: configures the collection of ARP priority level statistics for the specified ARP values.
- **no**: disables the collection of ARP priority level statistics for the specified **qci** and **arp** settings.

Associate a Stats Profile with an APN

Use the following example to access *APN Configuration Mode* and associate a Stats Profile with an APN:

```
configure
  apn apn_name
    stats-profile stats_profile_name
  end
```

To disassociate a Stats Profile from a specified APN:

```
configure
  apn apn_name
    no stats-profile
  end
```

Notes:

- *stats_profile_name*: must be the name of an existing Stats Profile. The name must be an alphanumeric string from 1 to 63 characters in length.
- A maximum of 64 Stats Profiles can be configured per P-GW/SAEGW/GGSN service.
- **no stats-profile**: disassociates the Stats Profile from the APN.



Important If a Stats Profile is associated with more than 12 APNs, the following memory and performance impact warning is provided:

```
[WARNING] Configuring QCI/ ARP level statistics for more then 12 APNs will have
memory and performance impact. Do you want to continue [Y/N]
```

Verify the Configuration

Use the following procedure to verify the configuration:

First, verify that the Stats Profile is associated with the correct APN. In *Exec Mode*, enter the following command:

```
show apn name apn_name
```

Notes:

- In the command output, look for the **stats profile** field. It should contain the name of the Stats Profile which is associated with this APN.

Next, verify that the Stats Profile configuration settings are correct. In *Exec Mode*, enter the following command:

```
show stats-profile name stats_profile_name
```

Notes:

- Where *stats_profile_name* is the name of the Stats Profile for which you want to view settings.
- The command output includes the following information:
 - Stats Profile name
 - Packet-drop configuration settings for both QCI and ARP
 - QCI ARP combinations for which the StarOS will collect granular ARP statistics

If any of the above settings are incorrect, perform the configuration procedure again to reconfigure the Stats Profile with the proper settings.

Monitoring Per QCI Packet Drop Counters and ARP Granularity for QCI Level Counters

This section describes how to monitor the Per QCI Packet Drop Counters and ARP Granularity for QCI Level Counters feature.

Bulk Statistics

This section provides the bulk statistics that have been added to support the ARP Granularity and per QCI Packet Drop Counters feature.

APN Schema

The following bulk statistics have been added to the APN Schema to support the New Standard QCIs feature.

```
qci65-actbear
qci65-setupbear
qci65-relbear
qci65-uplinkpkt-fwd
qci65-dwlinkpkt-fwd
qci65-uplinkbyte-fwd
qci65-dwlinkbyte-fwd
qci65-uplinkpkt-drop
qci65-dwlinkpkt-drop
qci65-uplinkbyte-drop
qci65-dwlinkbyte-drop
qci65-uplinkpkt-drop-mbrexcd
qci65-dwlinkpkt-drop-mbrexcd
qci65-uplinkbyte-drop-mbrexcd
qci65-dwlinkbyte-drop-mbrexcd
qci65-rejbearer
qci66-actbear
qci66-setupbear
qci66-relbear
qci66-uplinkpkt-fwd
qci66-dwlinkpkt-fwd
qci66-uplinkbyte-fwd
qci66-dwlinkbyte-fwd
qci66-uplinkpkt-drop
qci66-dwlinkpkt-drop
qci66-uplinkbyte-drop
qci66-dwlinkbyte-drop
qci66-uplinkpkt-drop-mbrexcd
qci66-dwlinkpkt-drop-mbrexcd
qci66-uplinkbyte-drop-mbrexcd
```

```

qci66-dwlinkbyte-drop-mbrexcd
qci66-rejbearer
qci69-actbear
qci69-setupbear
qci69-relbear
qci69-uplinkpkt-fwd
qci69-dwlinkpkt-fwd
qci69-uplinkbyte-fwd
qci69-dwlinkbyte-fwd
qci69-uplinkpkt-drop
qci69-dwlinkpkt-drop
qci69-uplinkbyte-drop
qci69-dwlinkbyte-drop
qci69-uplinkpkt-drop-mbrexcd
qci69-dwlinkpkt-drop-mbrexcd
qci69-uplinkbyte-drop-mbrexcd
qci69-dwlinkbyte-drop-mbrexcd
qci69-rejbearer
qci70-actbear
qci70-setupbear
qci70-relbear
qci70-uplinkpkt-fwd
qci70-dwlinkpkt-fwd
qci70-uplinkbyte-fwd
qci70-dwlinkbyte-fwd
qci70-uplinkpkt-drop
qci70-dwlinkpkt-drop
qci70-uplinkbyte-drop
qci70-dwlinkbyte-drop
qci70-uplinkpkt-drop-mbrexcd
qci70-dwlinkpkt-drop-mbrexcd
qci70-uplinkbyte-drop-mbrexcd
qci70-dwlinkbyte-drop-mbrexcd
qci70-rejbearer
sessstat-bearrel-ded-admin-clear-qci65
sessstat-bearrel-ded-admin-clear-qci66
sessstat-bearrel-ded-admin-clear-qci69
sessstat-bearrel-ded-admin-clear-qci70

```

Show Commands

This section provides the Exec Mode show commands that are available to support the Per Packet QCI Drop Counters and ARP Granularity for QCI Level Counters feature.

show apn statistics

The **qci** and **arp** keywords have been added to this command. The new keywords enable operators to view output for four basic scenarios that apply to the Per QCI Packet Drop Counters and ARP Granularity for QCI Level Counters feature.

Scenario 1

View packet drop counters with granularity at the QCI/ARP level for a single APN. The output of this command is useful for isolating network issues that may be affecting packet drops.

```

show apn statistics name apn_name qci { all | 1-9 | non-std { gbr | non-gbr
} } arp { all | 1-15 }

```

Notes:

- *apn_name*: must be the name of a configured APN created in *APN Configuration Mode*.

- **qci**: displays packet drop statistics for the specified QCI(s).
- **all**: displays packet drop statistics for all QCI(s).
- **1-9**: displays packet drop statistics for QCI <n>. Must be a QCI number from 1 to 9.
- **non-std**: displays packet drop statistics for non-standard QCIs.
- **non-gbr**: displays packet drop statistics for non-standard non-gbr QCIs
- **gbr**: displays packet drop statistics for non-standard GBR QCIs.
- **arp**: displays statistics for the specified ARP priority level(s)
- **all**: displays packet drop statistics for all ARP priority levels.
- **1-15**: displays statistics for the specified ARP priority level.

Scenario 2

View packet drop counters with granularity at the QCI/ARP level for all APNs.

```
show apn statistics qci { all | 1-9 | non-std { gbr | non-gbr } } arp {
all | 1-15 }
```

Notes:

- *apn_name*: must be the name of a configured APN created in *APN Configuration Mode*.
- **qci**: displays packet drop statistics for the specified QCI(s).
- **all**: displays packet drop statistics for all QCI(s).
- **1-9**: displays packet drop statistics for QCI <n>. Must be a QCI number from 1 to 9.
- **non-std**: displays packet drop statistics for non-standard QCIs.
- **non-gbr**: displays packet drop statistics for non-standard non-gbr QCIs
- **gbr**: displays packet drop statistics for non-standard GBR QCIs.
- **arp**: displays statistics for the specified ARP priority level(s)
- **all**: displays packet drop statistics for all ARP priority levels.
- **1-15**: displays statistics for the specified ARP priority level.

Scenario 3

View the new packet drop counters at granularity of QCI level, and pre-existing QCI level counters for the specified APN.

```
show apn statistics name apn_name qci { all | 1-9 | non-std { gbr | non-gbr
} }
```

Notes:

- *apn_name*: must be the name of a configured APN created in *APN Configuration Mode*.
- **qci**: displays packet drop statistics for the specified QCI(s).
- **all**: displays packet drop statistics for all QCI(s).

- **1-9**: displays packet drop statistics for QCI <n>. Must be a QCI number from 1 to 9.
- **non-std**: displays packet drop statistics for non-standard QCIs.
- **non-gbr**: displays packet drop statistics for non-standard non-gbr QCIs
- **gbr**: displays packet drop statistics for non-standard GBR QCIs.
- **arp**: displays statistics for the specified ARP priority level(s)
- **all**: displays packet drop statistics for all ARP priority levels.
- **1-15**: displays statistics for the specified ARP priority level.

Scenario 4

View the packet drop counters at the granularity of the QCI level, and view pre-existing QCI counters consolidated for all APNs.

```
show apn statistics qci { all | 1-9 | non-std { gbr | non-gbr } }
```

Notes:

- *apn_name*: must be the name of a configured APN created in *APN Configuration Mode*.
- **qci**: displays packet drop statistics for the specified QCI(s).
- **all**: displays packet drop statistics for all QCI(s).
- **1-9**: displays packet drop statistics for QCI <n>. Must be a QCI number from 1 to 9.
- **non-std**: displays packet drop statistics for non-standard QCIs.
- **non-gbr**: displays packet drop statistics for non-standard non-gbr QCIs
- **gbr**: displays packet drop statistics for non-standard GBR QCIs.
- **arp**: displays statistics for the specified ARP priority level(s)
- **all**: displays packet drop statistics for all ARP priority levels.
- **1-15**: displays statistics for the specified ARP priority level.

The output of the **show apn statistics name apn_name qci all arp all** command has been enhanced to display the following new statistics:

Data Statistics:

Uplink Bytes:	0	Downlink Bytes:	0
Uplink Pkts:	0	Downlink Pkts:	0
Uplink Bytes dropped:	0	Downlink Bytes dropped:	0
Uplink Pkts dropped:	0	Downlink Pkts dropped:	0
Uplink Dropped:		Downlink Dropped:	
MBR Exceeded(Bytes):	0	MBR Exceeded(Bytes):	0
MBR Exceeded(Pkts):	0	MBR Exceeded(Pkts):	0
AMBR Exceeded(Bytes):	0	AMBR Exceeded(Bytes):	0
AMBR Exceeded(Pkts):	0	AMBR Exceeded(Pkts):	0
Miscellaneous(Bytes):	0	Miscellaneous(Bytes):	0
Miscellaneous(Pkts):	0	Miscellaneous(Pkts):	0
Overcharge Prtctn(Bytes)	0	Overcharge Prtctn(Bytes):	0
Overcharge Prtctn(Pkts):	0	Overcharge Prtctn(Pkts):	0
SGW Restoration(Bytes):	0	SGW Restoration(Bytes):	0

SGW Restoration(Pkts):	0	SGW Restoration(Pkts):	0	
SDF Gate(Bytes):	0	SDF Gate(Bytes):	0	
SDF Gate(Pkts):	0	SDF Gate(Pkts):	0	
ITC Gate(Bytes):	0	ITC Gate(Bytes):	0	
ITC Gate(Pkts):	0	ITC Gate(Pkts):	0	
Flow Terminated(Bytes):	0	Flow Terminated(Bytes):	0	
Flow Terminated(Pkts):	0	Flow Terminated(Pkts):	0	
Subsession Terminated(Bytes):	0	Subsession Terminated(Bytes):	0	
Subsession Terminated(Pkts):	0	Subsession Terminated(Pkts):	0	
Call Terminated(Bytes):	0	Call Terminated(Bytes):	0	
Call Terminated(Pkts):	0	Call Terminated(Pkts):	0	
DCCA Discard(Bytes):	0	DCCA Discard(Bytes):	0	
DCCA Discard(Pkts):	0	DCCA Discard(Pkts):	0	
No Rule Match(Bytes):	0	No Rule Match(Bytes):	0	
No Rule Match(Pkts):	0	No Rule Match(Pkts):	0	
ICAP(Bytes):	0	ICAP(Bytes):	N/A	
ICAP(Pkts):	0	ICAP(Pkts):	N/A	
SFW(Bytes):	0	SFW(Bytes):	0	
SFW(Pkts):	0	SFW(Pkts):	0	
Hierarchical ENF(Bytes):	0	Hierarchical ENF(Bytes):	0	
Hierarchical ENF(Pkts):	0	Hierarchical ENF(Pkts):	0	
Dynamic CA Gate(Bytes):	0	Dynamic CA Gate(Bytes):	:	0
Dynamic CA Gate(Pkts):	0	Dynamic CA Gate(Pkts):	:	0
NAT64 Cancel(Bytes):	0	NAT64 Cancel(Bytes):	:	0
NAT64 Cancel(Pkts):	0	NAT64 Cancel(Pkts):	:	0
Bearer Not Found(Bytes):	0	Bearer Not Found(Bytes):	:	0
Bearer Not Found(Pkts):	0	Bearer Not Found(Pkts):	:	0

4G Bearers Released By Reasons:

	QCI1	QCI2	QCI3	QCI4	QCI5	QCI6	QCI7	QCI8	QCI9
Admin disconnect:	0	0	0	0	0	0	0	0	0

ARP level distribution of 4G Bearer Released By Reasons:

```

Admin disconnect:
QCI 1:
  ARP 1:      0
  ARP 2:      0
  ARP 3:      0
  ARP 4:      0
  ARP 5:      0
  ARP 6:      0
  ARP 7:      0
  ARP 8:      0
  ARP 9:      0
  ARP 10:     0
  ARP 11:     0
  ARP 12:     0
  ARP 13:     0
  ARP 14:     0
  ARP 15:     0
.
.
.
QCI 9:
  ARP 1:      0
  ARP 2:      0
  ARP 3:      0
  ARP 4:      0

```

```

ARP 5:      0
ARP 6:      0
ARP 7:      0
ARP 8:      0
ARP 9:      0
ARP 10:     0
ARP 11:     0
ARP 12:     0
ARP 13:     0
ARP 14:     0
ARP 15:     0

```

Subscriber QoS Statistics:

4G Bearers Released By Reasons:

	QCI1	QCI2	QCI3	QCI4	QCI5	QCI6	QCI7	QCI8	QCI9
Admin disconnect:	0	0	0	0	0	0	0	0	0

ARP level distribution of 4G Bearer Released By Reasons:

Admin disconnect:

```

QCI 1:
ARP 1:      0
ARP 2:      0
ARP 3:      0
ARP 4:      0
ARP 5:      0
ARP 6:      0
ARP 7:      0
ARP 8:      0
ARP 9:      0
ARP 10:     0
ARP 11:     0
ARP 12:     0
ARP 13:     0
ARP 14:     0
ARP 15:     0

```

```

.
.
.

```

```

QCI 9:
ARP 1:      0
ARP 2:      0
ARP 3:      0
ARP 4:      0
ARP 5:      0
ARP 6:      0
ARP 7:      0
ARP 8:      0
ARP 9:      0
ARP 10:     0
ARP 11:     0
ARP 12:     0
ARP 13:     0
ARP 14:     0
ARP 15:     0

```

```

QCI 1:

```

```

ARP 1:
  Bearer Active:          0   Bearer setup:          2
  Bearer Released:       2   Bearer Rejected:       0

  Uplink Bytes forwarded: 0   Downlink Bytes forwarded: 0
  Uplink Pkts forwarded: 0   Downlink Pkts forwarded: 0
  Uplink Bytes dropped:   0   Downlink Bytes dropped:  0
  Uplink Pkts dropped:   0   Downlink Pkts dropped:   0
Uplink Dropped:          Downlink Dropped:
  MBR Exceeded(Bytes):   0   MBR Exceeded(Bytes):   0
  MBR Exceeded(Pkts):    0   MBR Exceeded(Pkts):    0
  AMBR Exceeded(Bytes):  0   AMBR Exceeded(Bytes):  0
  AMBR Exceeded(Pkts):   0   AMBR Exceeded(Pkts):   0
  Miscellaneous(Bytes):  0   Miscellaneous(Bytes):  0
  Miscellaneous(Pkts):   0   Miscellaneous(Pkts):   0
  Overcharge Prtctn(Bytes) 0   Overcharge Prtctn(Bytes) 0
  Overcharge Prtctn(Pkts): 0   Overcharge Prtctn(Pkts): 0
  SGW Restoration(Bytes): 0   SGW Restoration(Bytes): 0
  SGW Restoration(Pkts):  0   SGW Restoration(Pkts):  0
  SDF Gate(Bytes):       0   SDF Gate(Bytes):       0
  SDF Gate(Pkts):        0   SDF Gate(Pkts):        0
  ITC Gate(Bytes):       0   ITC Gate(Bytes):       0
  ITC Gate(Pkts):        0   ITC Gate(Pkts):        0
  Flow Terminated(Bytes): 0   Flow Terminated(Bytes): 0
  Flow Terminated(Pkts): 0   Flow Terminated(Pkts): 0
  Subsession Terminated(Bytes): 0   Subsession Terminated(Bytes): 0
  Subsession Terminated(Pkts): 0   Subsession Terminated(Pkts): 0
  Call Terminated(Bytes): 0   Call Terminated(Bytes): 0
  Call Terminated(Pkts): 0   Call Terminated(Pkts): 0
  DCCA Discard(Bytes):    0   DCCA Discard(Bytes):    0
  DCCA Discard(Pkts):     0   DCCA Discard(Pkts):     0
  No Rule Match(Bytes):   0   No Rule Match(Bytes):   0
  No Rule Match(Pkts):    0   No Rule Match(Pkts):    0
  ICAP(Bytes):            0   ICAP(Bytes):            N/A
  ICAP(Pkts):             0   ICAP(Pkts):             N/A
  SFW(Bytes):             0   SFW(Bytes):             0
  SFW(Pkts):              0   SFW(Pkts):              0
  Hierarchical ENF(Bytes): 0   Hierarchical ENF(Bytes): 0
  Hierarchical ENF(Pkts): 0   Hierarchical ENF(Pkts): 0
  Dynamic CA Gate(Bytes): 0   Dynamic CA Gate(Bytes): 0
  Dynamic CA Gate(Pkts):  0   Dynamic CA Gate(Pkts):  0
  NAT64 Cancel(Bytes):    0   NAT64 Cancel(Bytes):    0
  NAT64 Cancel(Pkts):     0   NAT64 Cancel(Pkts):     0
  Bearer Not Found(Bytes): 0   Bearer Not Found(Bytes): 0
  Bearer Not Found(Pkts): 0   Bearer Not Found(Pkts): 0
QCI 1:
  ARP 2:
    Bearer Active:          0   Bearer setup:          2
    Bearer Released:       2   Bearer Rejected:       0

    Uplink Bytes forwarded: 0   Downlink Bytes forwarded: 0
    Uplink Pkts forwarded: 0   Downlink Pkts forwarded: 0
    Uplink Bytes dropped:   0   Downlink Bytes dropped:  0
    Uplink Pkts dropped:   0   Downlink Pkts dropped:   0
  Uplink Dropped:          Downlink Dropped:
    MBR Exceeded(Bytes):   0   MBR Exceeded(Bytes):   0
    MBR Exceeded(Pkts):    0   MBR Exceeded(Pkts):    0
    AMBR Exceeded(Bytes):  0   AMBR Exceeded(Bytes):  0
    AMBR Exceeded(Pkts):   0   AMBR Exceeded(Pkts):   0
    Miscellaneous(Bytes):  0   Miscellaneous(Bytes):  0
    Miscellaneous(Pkts):   0   Miscellaneous(Pkts):   0
    Overcharge Prtctn(Bytes) 0   Overcharge Prtctn(Bytes) 0
    Overcharge Prtctn(Pkts): 0   Overcharge Prtctn(Pkts): 0
    SGW Restoration(Bytes): 0   SGW Restoration(Bytes): 0

```

show apn statistics

```

SGW Restoration(Pkts):          0  SGW Restoration(Pkts):          0
SDF Gate(Bytes):                0  SDF Gate(Bytes):                0
SDF Gate(Pkts):                 0  SDF Gate(Pkts):                 0
ITC Gate(Bytes):                0  ITC Gate(Bytes):                0
ITC Gate(Pkts):                 0  ITC Gate(Pkts):                 0
Flow Terminated(Bytes):        0  Flow Terminated(Bytes):        0
Flow Terminated(Pkts):         0  Flow Terminated(Pkts):         0
Subsession Terminated(Bytes):  0  Subsession Terminated(Bytes):  0
Subsession Terminated(Pkts):   0  Subsession Terminated(Pkts):   0
Call Terminated(Bytes):        0  Call Terminated(Bytes):        0
Call Terminated(Pkts):         0  Call Terminated(Pkts):         0
DCCA Discard(Bytes):            0  DCCA Discard(Bytes):            0
DCCA Discard(Pkts):             0  DCCA Discard(Pkts):             0
No Rule Match(Bytes):           0  No Rule Match(Bytes):           0
No Rule Match(Pkts):            0  No Rule Match(Pkts):            0
ICAP(Bytes):                    0  ICAP(Bytes):                    0
ICAP(Pkts):                     0  ICAP(Pkts):                     0
SFW(Bytes):                      0  SFW(Bytes):                      0
SFW(Pkts):                      0  SFW(Pkts):                      0
Hierarchical ENF(Bytes):        0  Hierarchical ENF(Bytes):        0
Hierarchical ENF(Pkts):         0  Hierarchical ENF(Pkts):         0
Dynamic CA Gate(Bytes):         0  Dynamic CA Gate(Bytes):         0
Dynamic CA Gate(Pkts):          0  Dynamic CA Gate(Pkts):          0
NAT64 Cancel(Bytes):           0  NAT64 Cancel(Bytes):           0
NAT64 Cancel(Pkts):            0  NAT64 Cancel(Pkts):            0
Bearer Not Found(Bytes):        0  Bearer Not Found(Bytes):        0
Bearer Not Found(Pkts):         0  Bearer Not Found(Pkts):         0
ICAP(Bytes):                    0  ICAP(Bytes):                    0
ICAP(Pkts):                     0  ICAP(Pkts):                     0
SFW(Bytes):                      0  SFW(Bytes):                      0
SFW(Pkts):                      0  SFW(Pkts):                      0
Hierarchical ENF(Bytes):        0  Hierarchical ENF(Bytes):        0
Hierarchical ENF(Pkts):         0  Hierarchical ENF(Pkts):         0
Dynamic CA Gate(Bytes):         0  Dynamic CA Gate(Bytes):         0
Dynamic CA Gate(Pkts):          0  Dynamic CA Gate(Pkts):          0
NAT64 Cancel(Bytes):           0  NAT64 Cancel(Bytes):           0
NAT64 Cancel(Pkts):            0  NAT64 Cancel(Pkts):            0
Bearer Not Found(Bytes):        0  Bearer Not Found(Bytes):        0
Bearer Not Found(Pkts):         0  Bearer Not Found(Pkts):         0

```

The output of the **show apn statistics name** *apn_name* **qci all** command has been enhanced to display the following new statistics:

Data Statistics:

```

Uplink Bytes:                   0  Downlink Bytes:                   0
Uplink Pkts:                    0  Downlink Pkts:                    0
Uplink Bytes dropped:           0  Downlink Bytes dropped:           0
Uplink Pkts dropped:           0  Downlink Pkts dropped:           0

Uplink Dropped:                Downlink Dropped:
  MBR Exceeded(Bytes):         0  MBR Exceeded(Bytes):             0
  MBR Exceeded(Pkts):          0  MBR Exceeded(Pkts):             0
  AMBR Exceeded(Bytes):        0  AMBR Exceeded(Bytes):           0
  AMBR Exceeded(Pkts):         0  AMBR Exceeded(Pkts):           0
  Miscellaneous(Bytes):        0  Miscellaneous(Bytes):           0
  Miscellaneous(Pkts):         0  Miscellaneous(Pkts):           0
  Overcharge Prtctn(Bytes):     0  Overcharge Prtctn(Bytes):       0
  Overcharge Prtctn(Pkts):     0  Overcharge Prtctn(Pkts):       0
  SGW Restoration(Bytes):       0  SGW Restoration(Bytes):         0
  SGW Restoration(Pkts):       0  SGW Restoration(Pkts):         0
  SDF Gate(Bytes):              0  SDF Gate(Bytes):                0
  SDF Gate(Pkts):               0  SDF Gate(Pkts):                 0
  ITC Gate(Bytes):              0  ITC Gate(Bytes):                0
  ITC Gate(Pkts):               0  ITC Gate(Pkts):                 0
  Flow Terminated(Bytes):     0  Flow Terminated(Bytes):        0
  Flow Terminated(Pkts):      0  Flow Terminated(Pkts):         0
  Subsession Terminated(Bytes): 0  Subsession Terminated(Bytes):  0
  Subsession Terminated(Pkts): 0  Subsession Terminated(Pkts):   0
  Call Terminated(Bytes):      0  Call Terminated(Bytes):        0
  Call Terminated(Pkts):       0  Call Terminated(Pkts):         0
  DCCA Discard(Bytes):          0  DCCA Discard(Bytes):            0
  DCCA Discard(Pkts):           0  DCCA Discard(Pkts):            0
  No Rule Match(Bytes):         0  No Rule Match(Bytes):           0
  No Rule Match(Pkts):          0  No Rule Match(Pkts):            0
  ICAP(Bytes):                  0  ICAP(Bytes):                    0
  ICAP(Pkts):                   0  ICAP(Pkts):                     0

```

SFW(Bytes):	0	SFW(Bytes):	0	
SFW(Pkts):	0	SFW(Pkts):	0	
Hierarchical ENF(Bytes):	0	Hierarchical ENF(Bytes):	0	
Hierarchical ENF(Pkts):	0	Hierarchical ENF(Pkts):	0	
Dynamic CA Gate(Bytes):	0	Dynamic CA Gate(Bytes):	:	0
Dynamic CA Gate(Pkts):	0	Dynamic CA Gate(Pkts):		0
NAT64 Cancel(Bytes):	0	NAT64 Cancel(Bytes):		0
NAT64 Cancel(Pkts):	0	NAT64 Cancel(Pkts):		0
Bearer Not Found(Bytes):	0	Bearer Not Found(Bytes):		0
Bearer Not Found(Pkts):	0	Bearer Not Found(Pkts):		0

4G Bearers Released By Reasons:

	QCI1	QCI2	QCI3	QCI4	QCI5	QCI6	QCI7	QCI8	QCI9
Admin disconnect:	0	0	0	0	0	0	0	0	0

Subscriber QoS Statistics:

QCI 1:

Bearer Active:	0	Bearer setup:	0	
Bearer Released:	0	Bearer Rejected:	0	
Uplink Bytes forwarded:	0	Downlink Bytes forwarded:	0	
Uplink Pkts forwarded:	0	Downlink Pkts forwarded:	0	
Uplink Bytes dropped:	0	Downlink Bytes dropped:	0	
Uplink Pkts dropped:	0	Downlink Pkts dropped:	0	
Uplink Dropped:		Downlink Dropped:		
MBR Exceeded(Bytes):	0	MBR Exceeded(Bytes):	0	
MBR Exceeded(Pkts):	0	MBR Exceeded(Pkts):	0	
AMBR Exceeded(Bytes):	0	AMBR Exceeded(Bytes):	0	
AMBR Exceeded(Pkts):	0	AMBR Exceeded(Pkts):	0	
Miscellaneous(Bytes):	0	Miscellaneous(Bytes):	0	
Miscellaneous(Pkts):	0	Miscellaneous(Pkts):	0	
Overcharge Prtctn(Bytes)	0	Overcharge Prtctn(Bytes):	0	
Overcharge Prtctn(Pkts):	0	Overcharge Prtctn(Pkts):	0	
SGW Restoration(Bytes):	0	SGW Restoration(Bytes):	0	
SGW Restoration(Pkts):	0	SGW Restoration(Pkts):	0	
SDF Gate(Bytes):	0	SDF Gate(Bytes):	0	
SDF Gate(Pkts):	0	SDF Gate(Pkts):	0	
ITC Gate(Bytes):	0	ITC Gate(Bytes):	0	
ITC Gate(Pkts):	0	ITC Gate(Pkts):	0	
Flow Terminated(Bytes):	0	Flow Terminated(Bytes):	0	
Flow Terminated(Pkts):	0	Flow Terminated(Pkts):	0	
Subsession Terminated(Bytes):	0	Subsession Terminated(Bytes):	0	
Subsession Terminated(Pkts):	0	Subsession Terminated(Pkts):	0	
Call Terminated(Bytes):	0	Call Terminated(Bytes):	0	
Call Terminated(Pkts):	0	Call Terminated(Pkts):	0	
DCCA Discard(Bytes):	0	DCCA Discard(Bytes):	0	
DCCA Discard(Pkts):	0	DCCA Discard(Pkts):	0	
No Rule Match(Bytes):	0	No Rule Match(Bytes):	0	
No Rule Match(Pkts):	0	No Rule Match(Pkts):	0	
ICAP(Bytes):	0	ICAP(Bytes):	N/A	
ICAP(Pkts):	0	ICAP(Pkts):	N/A	
SFW(Bytes):	0	SFW(Bytes):	0	
SFW(Pkts):	0	SFW(Pkts):	0	
Hierarchical ENF(Bytes):	0	Hierarchical ENF(Bytes):	0	
Hierarchical ENF(Pkts):	0	Hierarchical ENF(Pkts):	0	
Dynamic CA Gate(Bytes):	0	Dynamic CA Gate(Bytes):	:	0
Dynamic CA Gate(Pkts):	0	Dynamic CA Gate(Pkts):		0
NAT64 Cancel(Bytes):	0	NAT64 Cancel(Bytes):		0
NAT64 Cancel(Pkts):	0	NAT64 Cancel(Pkts):		0
Bearer Not Found(Bytes):	0	Bearer Not Found(Bytes):		0

show configuration

```

Bearer Not Found(Pkts):          0  Bearer Not Found(Pkts):          0
.
.
.
QCI 9:
  Bearer Active:                  0  Bearer setup:                  0
  Bearer Released:               0  Bearer Rejected:              0

  Uplink Bytes forwarded:        0  Downlink Bytes forwarded:     0
  Uplink Pkts forwarded:         0  Downlink Pkts forwarded:      0
  Uplink Bytes dropped:          0  Downlink Bytes dropped:       0
  Uplink Pkts dropped:           0  Downlink Pkts dropped:        0

```

show configuration

The output of this command has been enhanced to show the Stats Profile configuration settings.

- stats-profile <stats_profile_name>
- qci <qci number> arp <arp number>
- packet-drop (if packet-drop is enabled)

show stats-profile name

This new command in *Exec Mode* shows the configuration settings for the specified Stats Profile.

- Stats Profile Name: <stats_profile_name>
- qci <qci number> arp <arp_number(s)>
- packet-drop <if packet drop is enabled>

DSCP Marking Based on Both QCI and ARP Values

Feature Description

P-GW allows users to perform DSCP marking based on QoS Class Identifier (QCI) values. This functionality has been expanded to include the Priority Level (PL) values 1-15 of Allocation and Retention Priority (ARP), which allows users to assign different DSCP values for bearers with the same QCI but different ARP priority values. For example, the ability to assign DSCP values based on QCI+ARP could be used to meet compliance on priority and emergency calling via VoLTE.

Applies to the P-GW for the following interfaces:

- S5
- S8
- SGi
- S2b

Applies to the S-GW for the following interfaces:

- S1-U
- S5
- S8
- S11
- S4

Relationships to Other Features

ECS populates the DSCP values in inner IP header. These values are fetched from the DSCP table by means of a sessmanager API. Since DSCP values are now available for QCI-ARP combination, the API is replaced by a wrapper API that will accept both QCI and ARP and provide the DSCP values to ECS in a new data structure.

The API will return correct values in the following scenarios:

1. QCI-DSCP table is not configured, or it is not associated for this session.
API will return an indication to ECS that table was not found.
2. Table is configured, but entry for the given QCI value is not present in the table.
API will not populate the structure and keep the same unaltered.
3. Entry for given QCI is present, but it is not available for the given QCI-ARP pair.
The default DSCP values for that particular QCI will be populated in the return structure.
4. Entry for given QCI-ARP combination is present.
The DSCP values for given QCI-ARP combination will be populated in the return structure.

Once values are received from SM, ECS caches these values and uses the cached values for marking the further packets. Another lookup into the table is done only when there is a mismatch between the currently cached QCI-ARP value and the current packet's QCI-ARP value. Therefore, any change in the QCI-ARP table would be affected for inner DSCP marking on existing flows only in case of QCI or ARP change.

Licensing

DSCP marking capability requires that a valid license key be installed. Contact your Cisco Account or Support representative for information on how to obtain a license.

How It Works

The expansion of functionality to allow assigning different DSCP values for bearers with the same QCI, but different APR values, works as follows.

- DSCP marking of packets based on QCI+ARP combination allowed
- QCI + ARP configuration will override any DSCP entry for that QCI+ARP combination
- QCI only DSCP entry will override all existing QCI+ARP configuration
- Applying associated DSCP marking for QCI+ARP for Uplink and Downlink functionality is also allowed

Configuring DSCP Marking Based on Both QCI and ARP Values

This section describes how to configure DSCP marking based on both QCI and ARP values.

Configuring QCI-QoS Mapping

Use the following example to create and map QCI and ARP values to enforceable Quality of Service (QoS) parameters:

```
configure
  qci-qos-mapping name
    qci num [ arp-priority-level arp_value ] [ downlink [ encaps-header {
copy-inner | dscp-marking dscp-marking-value } ] [ internal-qos priority
priority ] [ user-datagram dscp-marking dscp-marking-value ] ] [ uplink [
downlink] [ encaps-header { copy-inner | dscp-marking dscp-marking-value } ]
[ internal-qos priority priority ] [ user-datagram dscp-marking
dscp-marking-value ] ]
  end
```

Notes:

- The P-GW does not support non-standard QCI values unless a valid license key is installed. QCI values 1 through 9 are standard values defined in 3GPP TS 23.203; the P-GW supports these standard values. In addition, QCI values 65, 66, 69, and 70 can be used in StarOS release 21.0 and later. From 3GPP Release 8 onwards, operator-specific/non-standard QCIs are supported and carriers can define QCI 128- 254.
- **arp-priority-level** *arp_value*: Specifies the address retention priority (ARP) priority level. *arp_value* must be an integer from 1 through 15.
- The above configuration only shows one keyword example. Refer to the *QCI - QoS Mapping Configuration Mode Commands* chapter in the *Command Line Interface Reference* for more information on the **qci** command and other supported keywords.

Use the following example to disable QCI and ARP values:

```
configure
  qci-qos-mapping name
    no qci num [ arp-priority-level arp_value ]
  end
```

Associating QCI-QoS Mapping Configuration

Use the following example to specify that the P-GW service is to be associated with an existing QCI-QoS mapping configuration:

```
configure
  context context_name
    pgw-service pgw_service_name
      associate qci-qos-mapping name
    end
```

Notes:

- QCI-QoS mapping configurations are created in the AAA context.

Use the following example to specify that the S-GW service is to be associated with an existing QCI-QoS mapping configuration:

```
configure
context context_name
  sgw-service sgw_service_name
    associate qci-qos-mapping name
  end
```

Notes:

- QCI-QoS mapping configurations are created in the AAA context.

Configuring CS5 Marking for GTP-C

Use the following example to mark DSCP precedence CS5 on control packets:

```
configure
context context_name
  ggsn-service ggsn_service_name
    ip qos-dscp gtpc cs5
  end
```

Notes:

- Designates Class Selector 5 DSCP precedence for GTP-C packets.

Verifying the Configuration

Use the following command in Exec mode to display/verify the configuration.

```
show configuration
```

Monitoring DSCP Marking Based on Both QCI and ARP Values

Output of Show Commands

This section provides information regarding show commands and/or their outputs in support of DSCP marking based on both QCI and ARP values.

show qci-qos-mapping table all

The output of this command has been enhanced to show the ARP value:

- arp-priority-level

New Standard QCI Support

CDETS: CSCuy20910 - Support of new standard QCIs (65, 66, 69, 70)

Applicable Products: P-GW, SAEGW, S-GW

Feature Description

The P-GW/SAEGW/S-GW support additional new 3GPP-defined standard QCIs. QCIs 65, 66, 69, and 70 are now supported for Mission Critical and Push-to-Talk (MCPTT) applications. These new standard QCIs are supported in addition to the previously supported QCIs of 1 through 9, and operator-defined QCIs 128 through 254.

The StarOS will continue to reject QCIs 10 through 127 sent by the PCRF.

Licensing



Important

New Standard QCI Support is a licensed feature. Contact your Cisco account or support representative for licensing details.

How it Works

Although the 3GPP specification mentions that only QCIs 65 and 69 can co-exist, there is no hard restriction on the QCIs in the StarOS implementation of this feature, as that is applicable to the PCRF. The P-GW acts as a pass-through node and allows QCIs 65 and 69 if a different QCI combination is requested from PCRF.

With support for standard QCIs 65, 66, 69, and 70 present, the implementation has also added support across the following StarOS interfaces:

- **Gx:** Gx processes Default Bearer QoS and Rule Validation allowing the new Mission Critical (MC)/Push to Talk (PTT) QCIs. When the MC/PTT bit is not negotiated with the PCRF, the PCEF will reject the creation of a bearer or reject call setup.
- **sessmgr:** The P-GW sessmgr now processes the updating and modification of QoS. The P-GW rejects all UE initiated BRC creation for the new standard QCIs.
- **ECS:** ECS accepts the new standard QCIs when received from the PCRF and will reject them when either the license is not configured or the same is received in 3G. The ECS is able to update a Default bearer with this QoS change or create a Dedicated Bearer for the new standard QCIs.

Handoff Behavior

For Gn/Gp handoffs, local mapping via the CLI is supported so that the P-GW/SAEGW/S-GW is in sync with the MME-to-SGSN context transfer. The following scenarios are supported:

No Local QoS Mapping Present: When no local mapping is present for the new QCIs, a call handoff from 4G to 3G will be rejected.

Local QoS Mapping Present: Three scenarios are supported when local mapping is present:

- **Local Mapping present for MME-SGSN and PCRF Out of Synchronization:** When local mapping is present it is assumed that the QoS mapping in the P-GW is in sync with the mapping from the MME to SGSN. Even if the QoS mapping for one of the transferred PDPs during a Gn/Gp handoff is not in sync with MME-SGSN mapping, the P-GW/SAEGW/S-GW still continues with the handoff with the local mapping present. However, the CDR generated while waiting for the PCRF response during the handoff would be out of sync with the CDR's received after the handoff.

- **Mapping present for MME-SGSN and PCRF in Synchronization:** When local mapping is in sync with the MME-SGSN there is no difference in the CDR generated after the handoff.
- **Partial Mapping Present:** Partial mapping occurs when some MC/PTT QCI(s) have mapping and the remainder of the MC/PTT QCI(s) do not have mapping. In this case the call is dropped.

Expected Call Flow Output

This section provides detailed information on the expected call flow output for various scenarios with the New Standard QCI support feature:

- New Call Procedure
- Handoff Procedures
- UE Initiated Bearer Creation
- Bearer Creation
- Bearer Update

These sections describe new behaviors and provide behavior clarification for this feature. Behavior not described is similar to that for Standard QCIs.

New Call Procedure

This section provides detailed information on the expected call flow output for various new call procedure scenarios with the New Standard QCI Support feature.

Table 36: Expected Call Flow Output: New Call Procedure

Procedure (3G/4G/ S2b/S2a)	Pre-Condition	Call QCI Modification	Message Type	Request with Type Of QCI	PGW License	Gx Interface (Type of Re-mapped QCI received)			Expected Behavior
						CCA-I	CCA-U	RAR	
Setup 3G (GGSN)	N/A	N/A	Create PDP Req	Std QCI	Enabled	MC/PTT- Std QCI	N/A	N/A	Call rejected by application
Setup eHRPD	N/A	N/A	PBU	Std QCI	Enabled	MC/PTT- Std QCI	N/A	N/A	Call accepted and created with this rule
Setup 4G (RAT: S4-SGSN)	N/A	N/A	Create Session Req	Std QCI	Enabled	MC/PTT- Std QCI	N/A	N/A	Call accepted and created with this rule

Handoff Procedures

This section provides detailed information on expected call flow output for various handoff procedure scenarios with the New Standard QCI Support feature.

Table 37: Expected Call Flow Output: Handoff Procedures

Procedure (3G/4G/ S2b/S2a)	Pre-Condition	Call QCI Modification	Message Type	Request with Type Of QCI	PGW License	Gx Interface (Type of Re-mapped QCI received)			Expected Behavior
						CCA-I	CCA-U	RAR	
Default bearer existing for WiFi	Call existing with MC/PTT- QCI requested to handoff to MC/PTT- QCI	Create Session Req	MC/PTT - QCI	Enabled	N/A	MC/PTT- Std QCI received for default bearer	N/A	Handoff accepted and download MC/PTT Std QCI applied	

Procedure (3G/4G/ S2b/S2a)	Pre-Condition	Call QCI Modification	Message Type	Request with Type Of QCI	PGW License	Gx Interface (Type of Re-mapped QCI received)			Expected Behavior
						CCA-I	CCA-U	RAR	
GnGp Handoff (4G (LTE) to 3G (GGSN))	Update PDP request received for primary PDP and pending response (Local mapping present)	Call existing with MC/PTT- QCI requested to Std-QCI where mapping not received for few MC/PTT- QCI bearers	Update PDP Req	Partial mapping received from PCRF for MC/PTT- QCI to Std-QCI	Enabled	N/A	Partial mapped Std QCI for MC/PTT- QCIs received. Here mapping is not Received for some PDP bearers .	N/A	Handoff rejected and call drop Initiated
	Update PDP Request received for primary PDP and pending response (Local mapping present)	Call existing with MC/PTT- QCI requested to Std-QCI where no mapping received for few MC/PTT- QCI bearers	Update PDP Req	No mapping Received from PCRF for MC/PTT- QCI to Std-QCI	Enabled	N/A	No mapping received	N/A	Handoff rejected and call drop initiated
	Update PDP request received for primary PDP and pending response (No-Local Mapping Present)	Call existing with Std primary PDP & MC/PTT- QCI requested to Std-QCI	Update PDP Req	N/A	Enabled	N/A	MC/PTT update rules received for Std QCI dedicated bearers	N/A	MC/PTT QCI mapped rule associated dedicated bearer purged and handoff accepted
		Call existing with MC/PTT primary PDP	Update PDP Req	N/A	Enabled	N/A	N/A	N/A	

Procedure (3G/4G/ S2b/S2a)	Pre-Condition	Call QCI Modification	Message Type	Request with Type Of QCI	PGW License	Gx Interface (Type of Re-mapped QCI received)			Expected Behavior
						CCA-I	CCA-U	RAR	
	Update PDP Request received for primary PDP and pending response (No-local mapping present)								Handoff rejected and call drop Initiated (dropped before Initiating CCA-U for handoff)
	Update PDP Request received for primary PDP and pending response (Local mapping present)	Call existing with MC/PTT- QCI requested to Std-QCI	Update PDP Req	PCRF Timeout No Response received	Enabled	N/A	No response from PCRF / CCA-U timeout	N/A	Handoff rejected and call drop initiated
	Update PDP Request received for primary PDP and pending response. BCM mode is mixed. (Local mapping present and same as what QCI values comes in UPC during HO)	Call existing with MC/PTT- QCI requested to Std-QCI	Update PDP Req	Mapping received from PCRF for MC/PTT- QCI to Std-QCI	Enabled	N/A	All mapping received from PCRF	N/A	Handoff accepted
			Update PDP Req	N/A	Enabled	N/A	N/A	N/A	Handoff rejected and call drop initiated

Procedure (3G/4G/ S2b/S2a)	Pre-Condition	Call QCI Modification	Message Type	Request with Type Of QCI	PGW License	Gx Interface (Type of Re-mapped QCI received)			Expected Behavior
						CCA-I	CCA-U	RAR	
	Update PDP Request received for primary PDP and pending response. BCM mode is mixed. (Local mapping present and not same as what QCI values comes in UPC during HO).	Call existing with MC/PTT-QCI requested to Std-QCI							
	Update PDP Request received for primary PDP and pending response. BCM mode is UE Only. (Local mapping present and same as what QCI values come in UPC during HO)	Call existing with MC/PTT-QCI requested to Std-QCI	Update PDP Req	Mapping received from PCRF for MC/PTT-QCI to Std-QCI	Enabled	N/A	All mapping received from PCRF	N/A	Handoff accepted
		Call existing with MC/PTT-QCI requested to Std-QCI	Update PDP Req	Mapping received from PCRF for MC/PTT-QCI to Std-QCI	Enabled	N/A	All mapping received from PCRF	N/A	Handoff accepted

Procedure (3G/4G/ S2b/S2a)	Pre-Condition	Call QCI Modification	Message Type	Request with Type Of QCI	PGW License	Gx Interface (Type of Re-mapped QCI received)			Expected Behavior
						CCA-I	CCA-U	RAR	
	Update PDP Request received for primary PDP and pending response. BCM mode is UE Only. (Local mapping present and not same as what QCI values come in UPC during HO.)								
	Update PDP Request received for primary PDP and pending response (Local mapping present/not present)	Call existing with MC/PTT-QCI requested to Std-QCI. Also suppress-NRUPC UPC is configured at the GGSN service level.	Update PDP Req	N/A	Enabled	N/A	N/A	N/A	Handoff rejected and call drop initiated
	Update PDP Request received for primary PDP and response sent (Local mapping present)	Call existing with MC/PTT-QCI requested to Std-QCI mapping received for All MC/PTT-QCI bearers	Update PDP Req	Complete mapping Received from PCRF for MC/PTT-QCI to Std-QCI (as per Local MC/PTT to Std QCI mapping)	Enabled	N/A	All mapped Std QCI for MC/PTT-QCI	N/A	Handoff accepted

Procedure (3G/4G/ S2b/S2a)	Pre-Condition	Call QCI Modification	Message Type	Request with Type Of QCI	PGW License	Gx Interface (Type of Re-mapped QCI received)			Expected Behavior
						CCA-I	CCA-U	RAR	
	Update PDP Request received for primary PDP and response sent (Local mapping present)	Call existing with MC/PTT- QCI requested to Std-QCI mapping received for All MC/PTT- QCI bearers	Update PDP Req	Complete mapping received from PCRF for MC/PTT- QCI to Std-QCI (different from local MC/PTT to Std QCI mapping)	Enabled	N/A	All mapped Std QCI for MC/PTT- QCI	N/A	Handoff accepted and Update PDP Response sent for all bearers
eHRPD -> LTE	Create Session Req received with ho_ind = 1	Only one bearer existing with the call	Create Session Req	MC/PTT - QCI	Enabled	N/A	MC/PTT- Std QCI received with rules	N/A	Handoff accepted and dedicated bearer are created with the MC/PTT- Std QCI received.
LTE -> eHRPD	Default + dedicated bearer existing for LTE	Call existing with MC/PTT- QCI	PBU	N/A	Enabled	N/A	N/A	N/A	Handoff accepted and PBA is sent and dedicated bearer rules are added under single bearer

UE Initiated Bearer Creation

This section provides detailed information on the expected call flow output for various UE initiated bearer creation scenarios with the New Standard QCI Support feature.

Bearer Creation

Table 38: Expected Call Flow Output: UE Initiated Bearer Creation

Procedure (3G/4G/ S2b/S2a)	Pre-Condition	Call QCI Modification	Message Type	Request with Type Of QCI	PGW License	Gx Interface (Type of Re-mapped QCI received)			Expected Behavior
						CCA-I	CCA-U	RAR	
LTE UE Initiated Bearer	Default bearer existing for LTE	N/A	Bearer Resource Command	MC/PTT- Std QCI	N/A	N/A	N/A	N/A	BRC rejected by application
	Default bearer existing for LTE	N/A	Bearer Resource Command	Std QCI	Disabled	N/A	MC/PTT- Std dedicated QCI	N/A	BRC rejected / rule rejected with resource allocation failure
	Default bearer existing for LTE	N/A	Bearer Resource Command	Std QCI	Enabled	N/A	MC/PTT- Std dedicated QCI	N/A	BRC rejected /CBReq initiated with MC/PTT- Std QCI

Bearer Creation

This section provides detailed information on the expected call flow output for Bearer Creation scenarios with the New Standard QCI Support feature.

Table 39: Expected Call Flow Output: Bearer Creation

Procedure (3G/4G/ S2b/S2a)	Pre-Condition	Call QCI Modification	Message Type	Request with Type Of QCI	PGW License	Gx Interface (Type of Re-mapped QCI received)			Expected Behavior
						CCA-I	CCA-U	RAR	
GGSN secondary PDP creation	Primary PDP existing for GGSN	New secondary PDP requested with MC/PTT-Std- QCI	RAR Procedure	N/A	Enabled	N/A	N/A	Rules received with MC/PTT- Std QCI	CCR-I resource allocation failure for secondary PDP sent to PCRF

Bearer Update

This section provides detailed information on the expected call flow output for Bearer Update scenarios with the New Standard QCI Support feature.

Table 40: Expected Call Flow Output: Bearer Update

Procedure (3G/4G/ S2b/S2a)	Pre-Condition	Call QCI Modification	Message Type	Request with Type Of QCI	PGW License	Gx Interface (Type of Re-mapped QCI received)			Expected Behavior
						CCA-I	CCA-U	RAR	
GGSN Primary PDP QoS modification	Primary PDP existing for GGSN	Call existing with Std-QCI requested to MC/PTT- Std QCI modification	RAR Procedure	MC/PTT- Std QCI	Enabled	N/A	N/A	MC/PTT- Std QCI for primary PDP received	CCR-I QoS modification failure for primary PDP QoS modification rejected
GGSN Secondary PDP QoS Modification	Primary PDP & secondary PDP existing for GGSN	Call existing with Std-QCI requested to MC/PTT- Std QCI modification for secondary PDP	RAR Procedure	MC/PTT- Std QCI	Enabled	N/A	N/A	MC/PTT- Std QCI for secondary PDP with rules received	CCR-I resource allocation failure for secondary PDP QoS modification sent

Configuring New Standard QCIs

Configuring New Standard QCIs consists of the following tasks:

- Configuring QCI-QoS Mapping
- Configuring Local Mapping for Gn/Gp Support
- Configuring Transaction Rate Network Initiated Setup/Teardown Events
- Enable Mission Critical QCIs

Configuring QCI-QoS Mapping

Standard QCI options **65**, **66**, **69**, and **70** have been added to the **qci** command in *QCI-QoS Mapping Configuration Mode*.

To configure QCI-QoS Mapping for new standard QCIs:

```
configure
qci-qos-mapping qci_qos_map_name
qci { 1-9 | 65 | 66 | 69 | 70 }
end
```

To disable new QCI-QoS mapping for new standard QCIs:

```
configure
qci-qos-mapping qci_qos_map_name
```

```
no qci { 1-9 | 65 | 66 | 69 | 70 }
end
```

Notes:

- **qci** options 65 and 66 are available for guaranteed bit rate (GBR) network initiated QCI values only.
- **qci** options 69 and 70 are available for non-GBR network initiated QCI values only.
- **no** disables the specified standard **qci** value.

Configuring Local QCI Mapping for Gn/Gp QoS Support

Use the following example to configure local QCI mapping for Gn/Gp support:

```
configure
qci-qos-mapping mapping_name
qci { 1-9 | 65 | 66 | 69 | 70 } pre-rel8-qos-mapping qci_value
end
```

Notes:

- **qci**: When the MPS license is disabled, this value must be a Standard QoS Class Identifier (QCI) from 1 to 9. When the MPS license is enabled, this value must be a Standard QCI from 1 to 9, or 65, 66, 69, 70.
- **qci** 65 and 66 are Mission Critical/Push to Talk (MC/PTT) GBR values and values 69 and 70 are MC/PTT Non-GBR values.
- **qci** values 65 and 66 can only be mapped to QCI values 1 through 4, and QCI values 69 and 70 can only be mapped to QCI values 5 through 9.

Configuring Transaction Rate Network Initiated Setup/Teardown Events

To configure transaction rate network initiated setup/teardown events for new standard QCI values:

```
configure
transaction-rate nw-initiated-setup-teardown-events qci { 1-9 | 65 |
66 | 69 | 70 | 128-254 }
end
```

To disable transaction rate network initiated setup/teardown events for new standard QCI values:

```
configure
no transaction-rate nw-initiated-setup-teardown-events qci qci_value
end
```

Notes:

- **65** and **66** are available options for GBR network-initiated QCI values.
- **69** and **70** are available options for non-GBR network-initiated QCI values.
- **no** disables transaction rate network initiated setup/teardown events for the specified new standard QCI value.

Enable Mission Critical QCIs

The **mission-critical-qcis** keyword in the **diameter encode-supported-features** command is required for support between the PCEF and PCRF for new standard QCI support. Use the following example to enable mission critical QCIs in *Policy Control Configuration Mode*:

```
configure
context context_name
  ims-auth-service ims-ggsn-auth
  policy-control
    diameter encode-supported-features mission-critical-qcis
  end
```

To disable this feature, enter the following commands:

```
configure
context context_name
  ims-auth-service ims-ggsn-auth
  policy-control
    no diameter encode-supported-features
  end
```

Notes:



Important The LTE Wireless Priority Feature Set must be enabled to configure the **mission-critical-qcis** option. The LTE Wireless Priority Feature Set is a license-controlled feature. Contact your Cisco account or support representative for licensing details.

Verifying the Configuration

Use the following example to verify the new standard QCI configuration:

```
show qci-qos-mapping table name qci_qos_mapping_table_name
```

Notes:

- The command output provides all qci-qos mapping attributes, including the new standard qci number. If any of the attributes are incorrect, repeat the configuration procedure in this chapter to correct the settings.

Monitoring the Feature

This section describes how to monitor the New Standard QCI Support feature.

Bulk Statistics

This section lists the bulk statistics that have been added to support the New Standard QCIs feature.

APN Schema

The following bulk statistics have been added to the APN Schema to support the New Standard QCIs feature.

qci65-actbear
qci65-setupbear
qci65-relbear
qci65-uplinkpkt-fwd
qci65-dwlinkpkt-fwd
qci65-uplinkbyte-fwd
qci65-dwlinkbyte-fwd
qci65-uplinkpkt-drop
qci65-dwlinkpkt-drop
qci65-uplinkbyte-drop
qci65-dwlinkbyte-drop
qci65-uplinkpkt-drop-mbrexcd
qci65-dwlinkpkt-drop-mbrexcd
qci65-uplinkbyte-drop-mbrexcd
qci65-dwlinkbyte-drop-mbrexcd
qci65-rejbearer
qci66-actbear
qci66-setupbear
qci66-relbear
qci66-uplinkpkt-fwd
qci66-dwlinkpkt-fwd
qci66-uplinkbyte-fwd
qci66-dwlinkbyte-fwd
qci66-uplinkpkt-drop
qci66-dwlinkpkt-drop
qci66-uplinkbyte-drop
qci66-dwlinkbyte-drop
qci66-uplinkpkt-drop-mbrexcd
qci66-dwlinkpkt-drop-mbrexcd
qci66-uplinkbyte-drop-mbrexcd
qci66-dwlinkbyte-drop-mbrexcd
qci66-rejbearer
qci69-actbear
qci69-setupbear
qci69-relbear
qci69-uplinkpkt-fwd
qci69-dwlinkpkt-fwd
qci69-uplinkbyte-fwd
qci69-dwlinkbyte-fwd
qci69-uplinkpkt-drop
qci69-dwlinkpkt-drop
qci69-uplinkbyte-drop
qci69-dwlinkbyte-drop
qci69-uplinkpkt-drop-mbrexcd
qci69-dwlinkpkt-drop-mbrexcd
qci69-uplinkbyte-drop-mbrexcd
qci69-dwlinkbyte-drop-mbrexcd
qci69-rejbearer
qci70-actbear
qci70-setupbear
qci70-relbear
qci70-uplinkpkt-fwd
qci70-dwlinkpkt-fwd
qci70-uplinkbyte-fwd
qci70-dwlinkbyte-fwd
qci70-uplinkpkt-drop
qci70-dwlinkpkt-drop
qci70-uplinkbyte-drop
qci70-dwlinkbyte-drop
qci70-uplinkpkt-drop-mbrexcd
qci70-dwlinkpkt-drop-mbrexcd
qci70-uplinkbyte-drop-mbrexcd
qci70-dwlinkbyte-drop-mbrexcd
qci70-rejbearer

```
sessstat-bearrel-ded-admin-clear-qci65  
sessstat-bearrel-ded-admin-clear-qci66  
sessstat-bearrel-ded-admin-clear-qci69  
sessstat-bearrel-ded-admin-clear-qci70
```

GTPU Schema

The following bulk statistics have been added to the GTPU Schema to support the New Standard QCIs feature.

```
qci65-uplink-pkts  
qci65-uplink-bytes  
qci65-dwlink-pkts  
qci65-dwlink-byte  
qci65-pkts-discard  
qci65-bytes-discard  
qci66-uplink-pkts  
qci66-uplink-bytes  
qci66-dwlink-pkts  
qci66-dwlink-byte  
qci66-pkts-discard  
qci66-bytes-discard  
qci69-uplink-pkts  
qci69-uplink-bytes  
qci69-dwlink-pkts  
qci69-dwlink-byte  
qci69-pkts-discard  
qci69-bytes-discard  
qci70-uplink-pkts  
qci70-uplink-bytes  
qci70-dwlink-pkts  
qci70-dwlink-byte  
qci70-pkts-discard  
qci70-bytes-discard
```

P-GW Schema

The following bulk statistics have been added to the P-GW schema to support the New Standard QCIs feature.

```
subqosstat-bearact-qci65  
subqosstat-bearact-qci66  
subqosstat-bearact-qci69  
subqosstat-bearact-qci70  
subqosstat-bearsetup-qci65  
subqosstat-bearsetup-qci66  
subqosstat-bearsetup-qci69  
subqosstat-bearsetup-qci70  
subqosstat-bearrel-qci65  
subqosstat-bearrel-qci66  
subqosstat-bearrel-qci69  
subqosstat-bearrel-qci70  
subdatastat-uppktfwd-qci65  
subdatastat-uppktfwd-qci66  
subdatastat-uppktfwd-qci69  
subdatastat-uppktfwd-qci70  
subdatastat-upbytefwd-qci65  
subdatastat-upbytefwd-qci66  
subdatastat-upbytefwd-qci69  
subdatastat-upbytefwd-qci70  
subdatastat-downpktfwd-qci65  
subdatastat-downpktfwd-qci66  
subdatastat-downpktfwd-qci69  
subdatastat-downpktfwd-qci70  
subdatastat-downbytefwd-qci65  
subdatastat-downbytefwd-qci66
```

```

subdatastat-downbytefwd-qci69
subdatastat-downbytefwd-qci70
subdatastat-uppktdrop-qci65
subdatastat-uppktdrop-qci66
subdatastat-uppktdrop-qci69
subdatastat-uppktdrop-qci70
subdatastat-upbytedrop-qci65
subdatastat-upbytedrop-qci66
subdatastat-upbytedrop-qci69
subdatastat-upbytedrop-qci70
subdatastat-downpktdrop-qci65
subdatastat-downpktdrop-qci66
subdatastat-downpktdrop-qci69
subdatastat-downpktdrop-qci70
subdatastat-downbytedrop-qci65
subdatastat-downbytedrop-qci66
subdatastat-downbytedrop-qci69
subdatastat-downbytedrop-qci70
subdatastat-uppktdropmbrexc-qci65
subdatastat-uppktdropmbrexc-qci66
subdatastat-uppktdropmbrexc-qci69
subdatastat-uppktdropmbrexc-qci70
subdatastat-upbytedropmbrexc-qci65
subdatastat-upbytedropmbrexc-qci66
subdatastat-upbytedropmbrexc-qci69
subdatastat-upbytedropmbrexc-qci70
subdatastat-downpktdropmbrexc-qci65
subdatastat-downpktdropmbrexc-qci66
subdatastat-downpktdropmbrexc-qci69
subdatastat-downpktdropmbrexc-qci70
subdatastat-downbytedropmbrexc-qci65
subdatastat-downbytedropmbrexc-qci66
subdatastat-downbytedropmbrexc-qci69
subdatastat-downbytedropmbrexc-qci70

```

SAEGW Schema

The following bulk statistics have been added to the SAEGW Schema to support the New Standard QCIs feature.

```

sgw-totepsbearact-qci65
sgw-totepsbearact-qci66
sgw-totepsbearact-qci69
sgw-totepsbearact-qci70
sgw-totepsbearset-qci65
sgw-totepsbearset-qci66
sgw-totepsbearset-qci69
sgw-totepsbearset-qci70
sgw-totepsbearrel-qci65
sgw-totepsbearrel-qci66
sgw-totepsbearrel-qci69
sgw-totepsbearrel-qci70
sgw-totepsbearmod-qci65
sgw-totepsbearmod-qci66
sgw-totepsbearmod-qci69
sgw-totepsbearmod-qci70
sgw-totepsbearrel-dedrsn-pgw-qci65
sgw-totepsbearrel-dedrsn-pgw-qci66
sgw-totepsbearrel-dedrsn-pgw-qci69
sgw-totepsbearrel-dedrsn-pgw-qci70
sgw-totepsbearrel-dedrsn-slerr-qci65
sgw-totepsbearrel-dedrsn-slerr-qci66
sgw-totepsbearrel-dedrsn-slerr-qci69
sgw-totepsbearrel-dedrsn-slerr-qci70

```

sgw-totepsbearrel-dedrsn-s5err-qci65
sgw-totepsbearrel-dedrsn-s5err-qci66
sgw-totepsbearrel-dedrsn-s5err-qci69
sgw-totepsbearrel-dedrsn-s5err-qci70
sgw-totepsbearrel-dedrsn-s4err-qci65
sgw-totepsbearrel-dedrsn-s4err-qci66
sgw-totepsbearrel-dedrsn-s4err-qci69
sgw-totepsbearrel-dedrsn-s4err-qci70
sgw-totepsbearrel-dedrsn-s12err-qci65
sgw-totepsbearrel-dedrsn-s12err-qci66
sgw-totepsbearrel-dedrsn-s12err-qci69
sgw-totepsbearrel-dedrsn-s12err-qci70
sgw-totepsbearrel-dedrsn-local-qci65
sgw-totepsbearrel-dedrsn-local-qci66
sgw-totepsbearrel-dedrsn-local-qci69
sgw-totepsbearrel-dedrsn-local-qci70
sgw-totepsbearrel-dedrsn-pdn-qci65
sgw-totepsbearrel-dedrsn-pdn-qci66
sgw-totepsbearrel-dedrsn-pdn-qci69
sgw-totepsbearrel-dedrsn-pdn-qci70
sgw-totepsbearrel-dedrsn-pathfail-s1-u-qci65
sgw-totepsbearrel-dedrsn-pathfail-s1-u-qci66
sgw-totepsbearrel-dedrsn-pathfail-s1-u-qci69
sgw-totepsbearrel-dedrsn-pathfail-s1-u-qci70
sgw-totepsbearrel-dedrsn-pathfail-s5-u-qci65
sgw-totepsbearrel-dedrsn-pathfail-s5-u-qci66
sgw-totepsbearrel-dedrsn-pathfail-s5-u-qci69
sgw-totepsbearrel-dedrsn-pathfail-s5-u-qci70
sgw-totepsbearrel-dedrsn-pathfail-s5-qci65
sgw-totepsbearrel-dedrsn-pathfail-s5-qci66
sgw-totepsbearrel-dedrsn-pathfail-s5-qci69
sgw-totepsbearrel-dedrsn-pathfail-s5-qci70
sgw-totepsbearrel-dedrsn-pathfail-s11-qci65
sgw-totepsbearrel-dedrsn-pathfail-s11-qci66
sgw-totepsbearrel-dedrsn-pathfail-s11-qci69
sgw-totepsbearrel-dedrsn-pathfail-s11-qci70
sgw-totepsbearrel-dedrsn-pathfail-s12-qci65
sgw-totepsbearrel-dedrsn-pathfail-s12-qci66
sgw-totepsbearrel-dedrsn-pathfail-s12-qci69
sgw-totepsbearrel-dedrsn-pathfail-s12-qci70
sgw-totepsbearrel-dedrsn-pathfail-s4-u-qci65
sgw-totepsbearrel-dedrsn-pathfail-s4-u-qci66
sgw-totepsbearrel-dedrsn-pathfail-s4-u-qci69
sgw-totepsbearrel-dedrsn-pathfail-s4-u-qci70
sgw-totepsbearrel-dedrsn-inactivity-timeout-qci65
sgw-totepsbearrel-dedrsn-inactivity-timeout-qci66
sgw-totepsbearrel-dedrsn-inactivity-timeout-qci69
sgw-totepsbearrel-dedrsn-inactivity-timeout-qci70
sgw-totepsbearrel-dedrsn-other-qci65
sgw-totepsbearrel-dedrsn-other-qci66
sgw-totepsbearrel-dedrsn-other-qci69
sgw-totepsbearrel-dedrsn-other-qci70
sgw-datastat-ul-qci65totbyte
sgw-datastat-ul-qci65totpkt
sgw-datastat-ul-qci66totbyte
sgw-datastat-ul-qci66totpkt
sgw-datastat-ul-qci69totbyte
sgw-datastat-ul-qci69totpkt
sgw-datastat-ul-qci70totbyte
sgw-datastat-ul-qci70totpkt
sgw-datastat-ul-dropstat-qci65totbyte
sgw-datastat-ul-dropstat-qci65totpkt
sgw-datastat-ul-dropstat-qci66totbyte
sgw-datastat-ul-dropstat-qci66totpkt

```

sgw-datastat-ul-dropstat-qci69totbyte
sgw-datastat-ul-dropstat-qci69totpkt
sgw-datastat-ul-dropstat-qci70totbyte
sgw-datastat-ul-dropstat-qci70totpkt
sgw-datastat-dl-qci65totbyte
sgw-datastat-dl-qci65totpkt
sgw-datastat-dl-qci66totbyte
sgw-datastat-dl-qci66totpkt
sgw-datastat-dl-qci69totbyte
sgw-datastat-dl-qci69totpkt
sgw-datastat-dl-qci70totbyte
sgw-datastat-dl-qci70totpkt
sgw-datastat-dl-dropstat-qci65totbyte
sgw-datastat-dl-dropstat-qci65totpkt
sgw-datastat-dl-dropstat-qci66totbyte
sgw-datastat-dl-dropstat-qci66totpkt
sgw-datastat-dl-dropstat-qci69totbyte
sgw-datastat-dl-dropstat-qci69totpkt
sgw-datastat-dl-dropstat-qci70totbyte
sgw-datastat-dl-dropstat-qci70totpkt
sgw-slu-ul-qci65totbyte
sgw-slu-ul-qci65totpkt
sgw-slu-ul-qci66totbyte
sgw-slu-ul-qci66totpkt
sgw-slu-ul-qci69totbyte
sgw-slu-ul-qci69totpkt
sgw-slu-ul-qci70totbyte
sgw-slu-ul-qci70totpkt
sgw-slu-ul-drop-qci65totbyte
sgw-slu-ul-drop-qci65totpkt
sgw-slu-ul-drop-qci66totbyte
sgw-slu-ul-drop-qci66totpkt
sgw-slu-ul-drop-qci69totbyte
sgw-slu-ul-drop-qci69totpkt
sgw-slu-ul-drop-qci70totbyte
sgw-slu-ul-drop-qci70totpkt
sgw-slu-dl-qci65totbyte
sgw-slu-dl-qci65totpkt
sgw-slu-dl-qci66totbyte
sgw-slu-dl-qci66totpkt
sgw-slu-dl-qci69totbyte
sgw-slu-dl-qci69totpkt
sgw-slu-dl-qci70totbyte
sgw-slu-dl-qci70totpkt
sgw-slu-dl-drop-qci65totbyte
sgw-slu-dl-drop-qci65totpkt
sgw-slu-dl-drop-qci66totbyte
sgw-slu-dl-drop-qci66totpkt
sgw-slu-dl-drop-qci69totbyte
sgw-slu-dl-drop-qci69totpkt
sgw-slu-dl-drop-qci70totbyte
sgw-slu-dl-drop-qci70totpkt
sgw-s4u-ul-qci65totbyte
sgw-s4u-ul-qci65totpkt
sgw-s4u-ul-qci66totbyte
sgw-s4u-ul-qci66totpkt
sgw-s4u-ul-qci69totbyte
sgw-s4u-ul-qci69totpkt
sgw-s4u-ul-qci70totbyte
sgw-s4u-ul-qci70totpkt
sgw-s4u-ul-drop-qci65totbyte
sgw-s4u-ul-drop-qci65totpkt
sgw-s4u-ul-drop-qci66totbyte
sgw-s4u-ul-drop-qci66totpkt

```

sgw-s4u-ul-drop-qci69totbyte
sgw-s4u-ul-drop-qci69totpkt
sgw-s4u-ul-drop-qci70totbyte
sgw-s4u-ul-drop-qci70totpkt
sgw-s4u-dl-qci65totbyte
sgw-s4u-dl-qci65totpkt
sgw-s4u-dl-qci66totbyte
sgw-s4u-dl-qci66totpkt
sgw-s4u-dl-qci69totbyte
sgw-s4u-dl-qci69totpkt
sgw-s4u-dl-qci70totbyte
sgw-s4u-dl-qci70totpkt
sgw-s4u-dl-drop-qci65totbyte
sgw-s4u-dl-drop-qci65totpkt
sgw-s4u-dl-drop-qci66totbyte
sgw-s4u-dl-drop-qci66totpkt
sgw-s4u-dl-drop-qci69totbyte
sgw-s4u-dl-drop-qci69totpkt
sgw-s4u-dl-drop-qci70totbyte
sgw-s4u-dl-drop-qci70totpkt
sgw-s12-ul-qci65totbyte
sgw-s12-ul-qci65totpkt
sgw-s12-ul-qci66totbyte
sgw-s12-ul-qci66totpkt
sgw-s12-ul-qci69totbyte
sgw-s12-ul-qci69totpkt
sgw-s12-ul-qci70totbyte
sgw-s12-ul-qci70totpkt
sgw-s12-ul-drop-qci65totbyte
sgw-s12-ul-drop-qci65totpkt
sgw-s12-ul-drop-qci66totbyte
sgw-s12-ul-drop-qci66totpkt
sgw-s12-ul-drop-qci69totbyte
sgw-s12-ul-drop-qci69totpkt
sgw-s12-ul-drop-qci70totbyte
sgw-s12-ul-drop-qci70totpkt
sgw-s12-dl-qci65totbyte
sgw-s12-dl-qci65totpkt
sgw-s12-dl-qci66totbyte
sgw-s12-dl-qci66totpkt
sgw-s12-dl-qci69totbyte
sgw-s12-dl-qci69totpkt
sgw-s12-dl-qci70totbyte
sgw-s12-dl-qci70totpkt
sgw-s12-dl-drop-qci65totbyte
sgw-s12-dl-drop-qci65totpkt
sgw-s12-dl-drop-qci66totbyte
sgw-s12-dl-drop-qci66totpkt
sgw-s12-dl-drop-qci69totbyte
sgw-s12-dl-drop-qci69totpkt
sgw-s12-dl-drop-qci70totbyte
sgw-s12-dl-drop-qci70totpkt
sgw-s5-ul-qci65totbyte
sgw-s5-ul-qci65totpkt
sgw-s5-ul-qci66totbyte
sgw-s5-ul-qci66totpkt
sgw-s5-ul-qci69totbyte
sgw-s5-ul-qci69totpkt
sgw-s5-ul-qci70totbyte
sgw-s5-ul-qci70totpkt
sgw-s5-ul-drop-qci65totbyte
sgw-s5-ul-drop-qci65totpkt
sgw-s5-ul-drop-qci66totbyte
sgw-s5-ul-drop-qci66totpkt

```

sgw-s5-ul-drop-qci69totbyte
sgw-s5-ul-drop-qci69totpkt
sgw-s5-ul-drop-qci70totbyte
sgw-s5-ul-drop-qci70totpkt
sgw-s5-dl-qci65totbyte
sgw-s5-dl-qci65totpkt
sgw-s5-dl-qci66totbyte
sgw-s5-dl-qci66totpkt
sgw-s5-dl-qci69totbyte
sgw-s5-dl-qci69totpkt
sgw-s5-dl-qci70totbyte
sgw-s5-dl-qci70totpkt
sgw-s5-dl-drop-qci65totbyte
sgw-s5-dl-drop-qci65totpkt
sgw-s5-dl-drop-qci66totbyte
sgw-s5-dl-drop-qci66totpkt
sgw-s5-dl-drop-qci69totbyte
sgw-s5-dl-drop-qci69totpkt
sgw-s5-dl-drop-qci70totbyte
sgw-s5-dl-drop-qci70totpkt
sgw-s8-ul-qci65totbyte
sgw-s8-ul-qci65totpkt
sgw-s8-ul-qci66totbyte
sgw-s8-ul-qci66totpkt
sgw-s8-ul-qci69totbyte
sgw-s8-ul-qci69totpkt
sgw-s8-ul-qci70totbyte
sgw-s8-ul-qci70totpkt
sgw-s8-ul-drop-qci65totbyte
sgw-s8-ul-drop-qci65totpkt
sgw-s8-ul-drop-qci66totbyte
sgw-s8-ul-drop-qci66totpkt
sgw-s8-ul-drop-qci69totbyte
sgw-s8-ul-drop-qci69totpkt
sgw-s8-ul-drop-qci70totbyte
sgw-s8-ul-drop-qci70totpkt
sgw-s8-dl-qci65totbyte
sgw-s8-dl-qci65totpkt
sgw-s8-dl-qci66totbyte
sgw-s8-dl-qci66totpkt
sgw-s8-dl-qci69totbyte
sgw-s8-dl-qci69totpkt
sgw-s8-dl-qci70totbyte
sgw-s8-dl-qci70totpkt
sgw-s8-dl-drop-qci65totbyte
sgw-s8-dl-drop-qci65totpkt
sgw-s8-dl-drop-qci66totbyte
sgw-s8-dl-drop-qci66totpkt
sgw-s8-dl-drop-qci69totbyte
sgw-s8-dl-drop-qci69totpkt
sgw-s8-dl-drop-qci70totbyte
sgw-s8-dl-drop-qci70totpkt
sgw-s5s8-ul-qci65totbyte
sgw-s5s8-ul-qci65totpkt
sgw-s5s8-ul-qci66totbyte
sgw-s5s8-ul-qci66totpkt
sgw-s5s8-ul-qci69totbyte
sgw-s5s8-ul-qci69totpkt
sgw-s5s8-ul-qci70totbyte
sgw-s5s8-ul-qci70totpkt
sgw-s5s8-ul-drop-qci65totbyte
sgw-s5s8-ul-drop-qci65totpkt
sgw-s5s8-ul-drop-qci66totbyte
sgw-s5s8-ul-drop-qci66totpkt

```

sgw-s5s8-ul-drop-qci69totbyte
sgw-s5s8-ul-drop-qci69totpkt
sgw-s5s8-ul-drop-qci70totbyte
sgw-s5s8-ul-drop-qci70totpkt
sgw-s5s8-dl-qci65totbyte
sgw-s5s8-dl-qci65totpkt
sgw-s5s8-dl-qci66totbyte
sgw-s5s8-dl-qci66totpkt
sgw-s5s8-dl-qci69totbyte
sgw-s5s8-dl-qci69totpkt
sgw-s5s8-dl-qci70totbyte
sgw-s5s8-dl-qci70totpkt
sgw-s5s8-dl-drop-qci65totbyte
sgw-s5s8-dl-drop-qci65totpkt
sgw-s5s8-dl-drop-qci66totbyte
sgw-s5s8-dl-drop-qci66totpkt
sgw-s5s8-dl-drop-qci69totbyte
sgw-s5s8-dl-drop-qci69totpkt
sgw-s5s8-dl-drop-qci70totbyte
sgw-s5s8-dl-drop-qci70totpkt
pgw-subqosstat-bearact-qci65
pgw-subqosstat-bearact-qci66
pgw-subqosstat-bearact-qci69
pgw-subqosstat-bearact-qci70
pgw-subqosstat-bearset-qci65
pgw-subqosstat-bearset-qci66
pgw-subqosstat-bearset-qci69
pgw-subqosstat-bearset-qci70
pgw-subqosstat-bearrel-qci65
pgw-subqosstat-bearrel-qci66
pgw-subqosstat-bearrel-qci69
pgw-subqosstat-bearrel-qci70
pgw-subdatastat-ulpktfwd-qci65
pgw-subdatastat-ulpktfwd-qci66
pgw-subdatastat-ulpktfwd-qci69
pgw-subdatastat-ulpktfwd-qci70
pgw-subdatastat-ulbytefwd-qci65
pgw-subdatastat-ulbytefwd-qci66
pgw-subdatastat-ulbytefwd-qci69
pgw-subdatastat-ulbytefwd-qci70
pgw-subdatastat-dlpktfwd-qci65
pgw-subdatastat-dlpktfwd-qci66
pgw-subdatastat-dlpktfwd-qci69
pgw-subdatastat-dlpktfwd-qci70
pgw-subdatastat-dlbytefwd-qci65
pgw-subdatastat-dlbytefwd-qci66
pgw-subdatastat-dlbytefwd-qci69
pgw-subdatastat-dlbytefwd-qci70
pgw-subdatastat-ulpktdrop-qci65
pgw-subdatastat-ulpktdrop-qci66
pgw-subdatastat-ulpktdrop-qci69
pgw-subdatastat-ulpktdrop-qci70
pgw-subdatastat-ulbytedrop-qci65
pgw-subdatastat-ulbytedrop-qci66
pgw-subdatastat-ulbytedrop-qci69
pgw-subdatastat-ulbytedrop-qci70
pgw-subdatastat-dlpktdrop-qci65
pgw-subdatastat-dlpktdrop-qci66
pgw-subdatastat-dlpktdrop-qci69
pgw-subdatastat-dlpktdrop-qci70
pgw-subdatastat-dlbytedrop-qci65
pgw-subdatastat-dlbytedrop-qci66
pgw-subdatastat-dlbytedrop-qci69
pgw-subdatastat-dlbytedrop-qci70

pgw-subdatastat-ulpktdropmbrexc-qci65
 pgw-subdatastat-ulpktdropmbrexc-qci66
 pgw-subdatastat-ulpktdropmbrexc-qci69
 pgw-subdatastat-ulpktdropmbrexc-qci70
 pgw-subdatastat-ulbytedropmbrexc-qci65
 pgw-subdatastat-ulbytedropmbrexc-qci66
 pgw-subdatastat-ulbytedropmbrexc-qci69
 pgw-subdatastat-ulbytedropmbrexc-qci70
 pgw-subdatastat-dlpktdropmbrexc-qci65
 pgw-subdatastat-dlpktdropmbrexc-qci66
 pgw-subdatastat-dlpktdropmbrexc-qci69
 pgw-subdatastat-dlpktdropmbrexc-qci70
 pgw-subdatastat-dlbytedropmbrexc-qci65
 pgw-subdatastat-dlbytedropmbrexc-qci66
 pgw-subdatastat-dlbytedropmbrexc-qci69
 pgw-subdatastat-dlbytedropmbrexc-qci70
 collapsed-subdatastat-ulpktfwd-qci65
 collapsed-subdatastat-ulpktfwd-qci66
 collapsed-subdatastat-ulpktfwd-qci69
 collapsed-subdatastat-ulpktfwd-qci70
 collapsed-subdatastat-ulbytefwd-qci65
 collapsed-subdatastat-ulbytefwd-qci66
 collapsed-subdatastat-ulbytefwd-qci69
 collapsed-subdatastat-ulbytefwd-qci70
 collapsed-subdatastat-dlpktfwd-qci65
 collapsed-subdatastat-dlpktfwd-qci66
 collapsed-subdatastat-dlpktfwd-qci69
 collapsed-subdatastat-dlpktfwd-qci70
 collapsed-subdatastat-dlbytefwd-qci65
 collapsed-subdatastat-dlbytefwd-qci66
 collapsed-subdatastat-dlbytefwd-qci69
 collapsed-subdatastat-dlbytefwd-qci70
 collapsed-subdatastat-ulpktdrop-qci65
 collapsed-subdatastat-ulpktdrop-qci66
 collapsed-subdatastat-ulpktdrop-qci69
 collapsed-subdatastat-ulpktdrop-qci70
 collapsed-subdatastat-ulbytedrop-qci65
 collapsed-subdatastat-ulbytedrop-qci66
 collapsed-subdatastat-ulbytedrop-qci69
 collapsed-subdatastat-ulbytedrop-qci70
 collapsed-subdatastat-dlpktdrop-qci65
 collapsed-subdatastat-dlpktdrop-qci66
 collapsed-subdatastat-dlpktdrop-qci69
 collapsed-subdatastat-dlpktdrop-qci70
 collapsed-subdatastat-dlbytedrop-qci65
 collapsed-subdatastat-dlbytedrop-qci66
 collapsed-subdatastat-dlbytedrop-qci69
 collapsed-subdatastat-dlbytedrop-qci70
 collapsed-subqosstat-bearact-qci65
 collapsed-subqosstat-bearact-qci66
 collapsed-subqosstat-bearact-qci69
 collapsed-subqosstat-bearact-qci70
 collapsed-subqosstat-bearset-qci65
 collapsed-subqosstat-bearset-qci66
 collapsed-subqosstat-bearset-qci69
 collapsed-subqosstat-bearset-qci70
 collapsed-subqosstat-bearrel-qci65
 collapsed-subqosstat-bearrel-qci66
 collapsed-subqosstat-bearrel-qci69
 collapsed-subqosstat-bearrel-qci70
 saegw-ggsn-subqosstat-bearact-qci65
 saegw-ggsn-subqosstat-bearact-qci66
 saegw-ggsn-subqosstat-bearact-qci69
 saegw-ggsn-subqosstat-bearact-qci70

```

saegw-ggsn-subqosstat-bearset-qci65
saegw-ggsn-subqosstat-bearset-qci66
saegw-ggsn-subqosstat-bearset-qci69
saegw-ggsn-subqosstat-bearset-qci70
saegw-ggsn-subqosstat-bearrel-qci65
saegw-ggsn-subqosstat-bearrel-qci66
saegw-ggsn-subqosstat-bearrel-qci69
saegw-ggsn-subqosstat-bearrel-qci70
saegw-ggsn-subdatastat-ulpktfwd-qci65
saegw-ggsn-subdatastat-ulpktfwd-qci66
saegw-ggsn-subdatastat-ulpktfwd-qci69
saegw-ggsn-subdatastat-ulpktfwd-qci70
saegw-ggsn-subdatastat-ulbytefwd-qci65
saegw-ggsn-subdatastat-ulbytefwd-qci66
saegw-ggsn-subdatastat-ulbytefwd-qci69
saegw-ggsn-subdatastat-ulbytefwd-qci70
saegw-ggsn-subdatastat-dlpktfwd-qci65
saegw-ggsn-subdatastat-dlpktfwd-qci66
saegw-ggsn-subdatastat-dlpktfwd-qci69
saegw-ggsn-subdatastat-dlpktfwd-qci70
saegw-ggsn-subdatastat-dlbytefwd-qci65
saegw-ggsn-subdatastat-dlbytefwd-qci66
saegw-ggsn-subdatastat-dlbytefwd-qci69
saegw-ggsn-subdatastat-dlbytefwd-qci70
saegw-ggsn-subdatastat-ulpktdrop-qci65
saegw-ggsn-subdatastat-ulpktdrop-qci66
saegw-ggsn-subdatastat-ulpktdrop-qci69
saegw-ggsn-subdatastat-ulpktdrop-qci70
saegw-ggsn-subdatastat-ulbytedrop-qci65
saegw-ggsn-subdatastat-ulbytedrop-qci66
saegw-ggsn-subdatastat-ulbytedrop-qci69
saegw-ggsn-subdatastat-ulbytedrop-qci70
saegw-ggsn-subdatastat-dlpktdrop-qci65
saegw-ggsn-subdatastat-dlpktdrop-qci66
saegw-ggsn-subdatastat-dlpktdrop-qci69
saegw-ggsn-subdatastat-dlpktdrop-qci70
saegw-ggsn-subdatastat-dlbytedrop-qci65
saegw-ggsn-subdatastat-dlbytedrop-qci66
saegw-ggsn-subdatastat-dlbytedrop-qci69
saegw-ggsn-subdatastat-dlbytedrop-qci70
saegw-ggsn-subdatastat-ulpktdropmbrexc-qci65
saegw-ggsn-subdatastat-ulpktdropmbrexc-qci66
saegw-ggsn-subdatastat-ulpktdropmbrexc-qci69
saegw-ggsn-subdatastat-ulpktdropmbrexc-qci70
saegw-ggsn-subdatastat-ulbytedropmbrexc-qci65
saegw-ggsn-subdatastat-ulbytedropmbrexc-qci66
saegw-ggsn-subdatastat-ulbytedropmbrexc-qci69
saegw-ggsn-subdatastat-ulbytedropmbrexc-qci70
saegw-ggsn-subdatastat-dlpktdropmbrexc-qci65
saegw-ggsn-subdatastat-dlpktdropmbrexc-qci66
saegw-ggsn-subdatastat-dlpktdropmbrexc-qci69
saegw-ggsn-subdatastat-dlpktdropmbrexc-qci70
saegw-ggsn-subdatastat-dlbytedropmbrexc-qci65
saegw-ggsn-subdatastat-dlbytedropmbrexc-qci66
saegw-ggsn-subdatastat-dlbytedropmbrexc-qci69
saegw-ggsn-subdatastat-dlbytedropmbrexc-qci70

```

S-GW Schema

The following bulk statistics have been added to the S-GW schema to support the New Standard QCIs feature.

```

totepsbearactive-qci65
totepsbearactive-qci66
totepsbearactive-qci69

```

totepsbearactive-qci70
totepsbearsetup-qci65
totepsbearsetup-qci66
totepsbearsetup-qci69
totepsbearsetup-qci70
totepsbearrel-qci65
totepsbearrel-qci66
totepsbearrel-qci69
totepsbearrel-qci70
totepsbearmod-qci65
totepsbearmod-qci66
totepsbearmod-qci69
totepsbearmod-qci70
totepsbearrel-dedrsn-pgw-qci65
totepsbearrel-dedrsn-pgw-qci66
totepsbearrel-dedrsn-pgw-qci69
totepsbearrel-dedrsn-pgw-qci70
totepsbearrel-dedrsn-slerr-qci65
totepsbearrel-dedrsn-slerr-qci66
totepsbearrel-dedrsn-slerr-qci69
totepsbearrel-dedrsn-slerr-qci70
totepsbearrel-dedrsn-s5err-qci65
totepsbearrel-dedrsn-s5err-qci66
totepsbearrel-dedrsn-s5err-qci69
totepsbearrel-dedrsn-s5err-qci70
totepsbearrel-dedrsn-s4err-qci65
totepsbearrel-dedrsn-s4err-qci66
totepsbearrel-dedrsn-s4err-qci69
totepsbearrel-dedrsn-s4err-qci70
totepsbearrel-dedrsn-s12err-qci65
totepsbearrel-dedrsn-s12err-qci66
totepsbearrel-dedrsn-s12err-qci69
totepsbearrel-dedrsn-s12err-qci70
totepsbearrel-dedrsn-local-qci65
totepsbearrel-dedrsn-local-qci66
totepsbearrel-dedrsn-local-qci69
totepsbearrel-dedrsn-local-qci70
totepsbearrel-dedrsn-pdn-qci65
totepsbearrel-dedrsn-pdn-qci66
totepsbearrel-dedrsn-pdn-qci69
totepsbearrel-dedrsn-pdn-qci70
totepsbearrel-dedrsn-pathfail-s1-u-qci65
totepsbearrel-dedrsn-pathfail-s1-u-qci66
totepsbearrel-dedrsn-pathfail-s1-u-qci69
totepsbearrel-dedrsn-pathfail-s1-u-qci70
totepsbearrel-dedrsn-pathfail-s5-u-qci65
totepsbearrel-dedrsn-pathfail-s5-u-qci66
totepsbearrel-dedrsn-pathfail-s5-u-qci69
totepsbearrel-dedrsn-pathfail-s5-u-qci70
totepsbearrel-dedrsn-pathfail-s5-qci65
totepsbearrel-dedrsn-pathfail-s5-qci66
totepsbearrel-dedrsn-pathfail-s5-qci69
totepsbearrel-dedrsn-pathfail-s5-qci70
totepsbearrel-dedrsn-pathfail-s11-qci65
totepsbearrel-dedrsn-pathfail-s11-qci66
totepsbearrel-dedrsn-pathfail-s11-qci69
totepsbearrel-dedrsn-pathfail-s11-qci70
totepsbearrel-dedrsn-pathfail-s12-qci65
totepsbearrel-dedrsn-pathfail-s12-qci66
totepsbearrel-dedrsn-pathfail-s12-qci69
totepsbearrel-dedrsn-pathfail-s12-qci70
totepsbearrel-dedrsn-pathfail-s4-u-qci65
totepsbearrel-dedrsn-pathfail-s4-u-qci66
totepsbearrel-dedrsn-pathfail-s4-u-qci69

totepsbearrel-dedrsn-pathfail-s4-u-qci70
totepsbearrel-dedrsn-inactivity-timeout-qci65
totepsbearrel-dedrsn-inactivity-timeout-qci66
totepsbearrel-dedrsn-inactivity-timeout-qci69
totepsbearrel-dedrsn-inactivity-timeout-qci70
totepsbearrel-dedrsn-other-qci65
totepsbearrel-dedrsn-other-qci66
totepsbearrel-dedrsn-other-qci69
totepsbearrel-dedrsn-other-qci70
datastat-uplink-qci65totbyte
datastat-uplink-qci65totpkt
datastat-uplink-qci66totbyte
datastat-uplink-qci66totpkt
datastat-uplink-qci69totbyte
datastat-uplink-qci69totpkt
datastat-uplink-qci70totbyte
datastat-uplink-qci70totpkt
datastat-uplink-dropstat-qci65totbyte
datastat-uplink-dropstat-qci65totpkt
datastat-uplink-dropstat-qci66totbyte
datastat-uplink-dropstat-qci66totpkt
datastat-uplink-dropstat-qci69totbyte
datastat-uplink-dropstat-qci69totpkt
datastat-uplink-dropstat-qci70totbyte
datastat-uplink-dropstat-qci70totpkt
datastat-downlink-qci65totbyte
datastat-downlink-qci65totpkt
datastat-downlink-qci66totbyte
datastat-downlink-qci66totpkt
datastat-downlink-qci69totbyte
datastat-downlink-qci69totpkt
datastat-downlink-qci70totbyte
datastat-downlink-qci70totpkt
datastat-downlink-dropstat-qci65totbyte
datastat-downlink-dropstat-qci65totpkt
datastat-downlink-dropstat-qci66totbyte
datastat-downlink-dropstat-qci66totpkt
datastat-downlink-dropstat-qci69totbyte
datastat-downlink-dropstat-qci69totpkt
datastat-downlink-dropstat-qci70totbyte
datastat-downlink-dropstat-qci70totpkt
slu-uplnk-qci65totbyte
slu-uplnk-qci65totpkt
slu-uplnk-qci66totbyte
slu-uplnk-qci66totpkt
slu-uplnk-qci69totbyte
slu-uplnk-qci69totpkt
slu-uplnk-qci70totbyte
slu-uplnk-qci70totpkt
slu-uplnk-drop-qci65totbyte
slu-uplnk-drop-qci65totpkt
slu-uplnk-drop-qci66totbyte
slu-uplnk-drop-qci66totpkt
slu-uplnk-drop-qci69totbyte
slu-uplnk-drop-qci69totpkt
slu-uplnk-drop-qci70totbyte
slu-uplnk-drop-qci70totpkt
slu-downlnk-qci65totbyte
slu-downlnk-qci65totpkt
slu-downlnk-qci66totbyte
slu-downlnk-qci66totpkt
slu-downlnk-qci69totbyte
slu-downlnk-qci69totpkt
slu-downlnk-qci70totbyte

```
s1u-downlnk-qci70totpkt
s1u-downlnk-drop-qci65totbyte
s1u-downlnk-drop-qci65totpkt
s1u-downlnk-drop-qci66totbyte
s1u-downlnk-drop-qci66totpkt
s1u-downlnk-drop-qci69totbyte
s1u-downlnk-drop-qci69totpkt
s1u-downlnk-drop-qci70totbyte
s1u-downlnk-drop-qci70totpkt
s4u-uplnk-qci65totbyte
s4u-uplnk-qci65totpkt
s4u-uplnk-qci66totbyte
s4u-uplnk-qci66totpkt
s4u-uplnk-qci69totbyte
s4u-uplnk-qci69totpkt
s4u-uplnk-qci70totbyte
s4u-uplnk-qci70totpkt
s4u-uplnk-drop-qci65totbyte
s4u-uplnk-drop-qci65totpkt
s4u-uplnk-drop-qci66totbyte
s4u-uplnk-drop-qci66totpkt
s4u-uplnk-drop-qci69totbyte
s4u-uplnk-drop-qci69totpkt
s4u-uplnk-drop-qci70totbyte
s4u-uplnk-drop-qci70totpkt
s4u-downlnk-qci65totbyte
s4u-downlnk-qci65totpkt
s4u-downlnk-qci66totbyte
s4u-downlnk-qci66totpkt
s4u-downlnk-qci69totbyte
s4u-downlnk-qci69totpkt
s4u-downlnk-qci70totbyte
s4u-downlnk-qci70totpkt
s4u-downlnk-drop-qci65totbyte
s4u-downlnk-drop-qci65totpkt
s4u-downlnk-drop-qci66totbyte
s4u-downlnk-drop-qci66totpkt
s4u-downlnk-drop-qci69totbyte
s4u-downlnk-drop-qci69totpkt
s4u-downlnk-drop-qci70totbyte
s4u-downlnk-drop-qci70totpkt
s12-uplnk-qci65totbyte
s12-uplnk-qci65totpkt
s12-uplnk-qci66totbyte
s12-uplnk-qci66totpkt
s12-uplnk-qci69totbyte
s12-uplnk-qci69totpkt
s12-uplnk-qci70totbyte
s12-uplnk-qci70totpkt
s12-uplnk-drop-qci65totbyte
s12-uplnk-drop-qci65totpkt
s12-uplnk-drop-qci66totbyte
s12-uplnk-drop-qci66totpkt
s12-uplnk-drop-qci69totbyte
s12-uplnk-drop-qci69totpkt
s12-uplnk-drop-qci70totbyte
s12-uplnk-drop-qci70totpkt
s12-downlnk-qci65totbyte
s12-downlnk-qci65totpkt
s12-downlnk-qci66totbyte
s12-downlnk-qci66totpkt
s12-downlnk-qci69totbyte
s12-downlnk-qci69totpkt
s12-downlnk-qci70totbyte
```

s12-downlnk-qci70totpkt
s12-downlnk-drop-qci65totbyte
s12-downlnk-drop-qci65totpkt
s12-downlnk-drop-qci66totbyte
s12-downlnk-drop-qci66totpkt
s12-downlnk-drop-qci69totbyte
s12-downlnk-drop-qci69totpkt
s12-downlnk-drop-qci70totbyte
s12-downlnk-drop-qci70totpkt
s5-uplnk-qci65totbyte
s5-uplnk-qci65totpkt
s5-uplnk-qci66totbyte
s5-uplnk-qci66totpkt
s5-uplnk-qci69totbyte
s5-uplnk-qci69totpkt
s5-uplnk-qci70totbyte
s5-uplnk-qci70totpkt
s5-uplnk-drop-qci65totbyte
s5-uplnk-drop-qci65totpkt
s5-uplnk-drop-qci66totbyte
s5-uplnk-drop-qci66totpkt
s5-uplnk-drop-qci69totbyte
s5-uplnk-drop-qci69totpkt
s5-uplnk-drop-qci70totbyte
s5-uplnk-drop-qci70totpkt
s5-downlnk-qci65totbyte
s5-downlnk-qci65totpkt
s5-downlnk-qci66totbyte
s5-downlnk-qci66totpkt
s5-downlnk-qci69totbyte
s5-downlnk-qci69totpkt
s5-downlnk-qci70totbyte
s5-downlnk-qci70totpkt
s5-downlnk-drop-qci65totbyte
s5-downlnk-drop-qci65totpkt
s5-downlnk-drop-qci66totbyte
s5-downlnk-drop-qci66totpkt
s5-downlnk-drop-qci69totbyte
s5-downlnk-drop-qci69totpkt
s5-downlnk-drop-qci70totbyte
s5-downlnk-drop-qci70totpkt
s8-uplnk-qci65totbyte
s8-uplnk-qci65totpkt
s8-uplnk-qci66totbyte
s8-uplnk-qci66totpkt
s8-uplnk-qci69totbyte
s8-uplnk-qci69totpkt
s8-uplnk-qci70totbyte
s8-uplnk-qci70totpkt
s8-uplnk-drop-qci65totbyte
s8-uplnk-drop-qci65totpkt
s8-uplnk-drop-qci66totbyte
s8-uplnk-drop-qci66totpkt
s8-uplnk-drop-qci69totbyte
s8-uplnk-drop-qci69totpkt
s8-uplnk-drop-qci70totbyte
s8-uplnk-drop-qci70totpkt
s8-downlnk-qci65totbyte
s8-downlnk-qci65totpkt
s8-downlnk-qci66totbyte
s8-downlnk-qci66totpkt
s8-downlnk-qci69totbyte
s8-downlnk-qci69totpkt
s8-downlnk-qci70totbyte

```

s8-downlnk-qci70totpkt
s8-downlnk-drop-qci65totbyte
s8-downlnk-drop-qci65totpkt
s8-downlnk-drop-qci66totbyte
s8-downlnk-drop-qci66totpkt
s8-downlnk-drop-qci69totbyte
s8-downlnk-drop-qci69totpkt
s8-downlnk-drop-qci70totbyte
s8-downlnk-drop-qci70totpkt
s5s8-uplnk-qci65totbyte
s5s8-uplnk-qci65totpkt
s5s8-uplnk-qci66totbyte
s5s8-uplnk-qci66totpkt
s5s8-uplnk-qci69totbyte
s5s8-uplnk-qci69totpkt
s5s8-uplnk-qci70totbyte
s5s8-uplnk-qci70totpkt
s5s8-uplnk-drop-qci65totbyte
s5s8-uplnk-drop-qci65totpkt
s5s8-uplnk-drop-qci66totbyte
s5s8-uplnk-drop-qci66totpkt
s5s8-uplnk-drop-qci69totbyte
s5s8-uplnk-drop-qci69totpkt
s5s8-uplnk-drop-qci70totbyte
s5s8-uplnk-drop-qci70totpkt
s5s8-downlnk-qci65totbyte
s5s8-downlnk-qci65totpkt
s5s8-downlnk-qci66totbyte
s5s8-downlnk-qci66totpkt
s5s8-downlnk-qci69totbyte
s5s8-downlnk-qci69totpkt
s5s8-downlnk-qci70totbyte
s5s8-downlnk-qci70totpkt
s5s8-downlnk-drop-qci65totbyte
s5s8-downlnk-drop-qci65totpkt
s5s8-downlnk-drop-qci66totbyte
s5s8-downlnk-drop-qci66totpkt
s5s8-downlnk-drop-qci69totbyte
s5s8-downlnk-drop-qci69totpkt
s5s8-downlnk-drop-qci70totbyte
s5s8-downlnk-drop-qci70totpkt

```

System Schema

The following bulk statistics have been added to the System Schema to support the New Standard QCIs feature.

```

sess-bearerdur-5sec-qci65
sess-bearerdur-10sec-qci65
sess-bearerdur-30sec-qci65
sess-bearerdur-1min-qci65
sess-bearerdur-2min-qci65
sess-bearerdur-5min-qci65
sess-bearerdur-15min-qci65
sess-bearerdur-30min-qci65
sess-bearerdur-1hr-qci65
sess-bearerdur-4hr-qci65
sess-bearerdur-12hr-qci65
sess-bearerdur-24hr-qci65
sess-bearerdur-over24hr-qci65
sess-bearerdur-2day-qci65
sess-bearerdur-4day-qci65
sess-bearerdur-5day-qci65
sess-bearerdur-5sec-qci66

```

```

sess-bearerdur-10sec-qci66
sess-bearerdur-30sec-qci66
sess-bearerdur-1min-qci66
sess-bearerdur-2min-qci66
sess-bearerdur-5min-qci66
sess-bearerdur-15min-qci66
sess-bearerdur-30min-qci66
sess-bearerdur-1hr-qci66
sess-bearerdur-4hr-qci66
sess-bearerdur-12hr-qci66
sess-bearerdur-24hr-qci66
sess-bearerdur-over24hr-qci66
sess-bearerdur-2day-qci66
sess-bearerdur-4day-qci66
sess-bearerdur-5day-qci66
sess-bearerdur-5sec-qci69
sess-bearerdur-10sec-qci69
sess-bearerdur-30sec-qci69
sess-bearerdur-1min-qci69
sess-bearerdur-2min-qci69
sess-bearerdur-5min-qci69
sess-bearerdur-15min-qci69
sess-bearerdur-30min-qci69
sess-bearerdur-1hr-qci69
sess-bearerdur-4hr-qci69
sess-bearerdur-12hr-qci69
sess-bearerdur-24hr-qci69
sess-bearerdur-over24hr-qci69
sess-bearerdur-2day-qci69
sess-bearerdur-4day-qci69
sess-bearerdur-5day-qci69
sess-bearerdur-5sec-qci70
sess-bearerdur-10sec-qci70
sess-bearerdur-30sec-qci70
sess-bearerdur-1min-qci70
sess-bearerdur-2min-qci70
sess-bearerdur-5min-qci70
sess-bearerdur-15min-qci70
sess-bearerdur-30min-qci70
sess-bearerdur-1hr-qci70
sess-bearerdur-4hr-qci70
sess-bearerdur-12hr-qci70
sess-bearerdur-24hr-qci70
sess-bearerdur-over24hr-qci70
sess-bearerdur-2day-qci70
sess-bearerdur-4day-qci70
sess-bearerdur-5day-qci70

```

Show Commands

This section describes the show commands available to monitor the New Standard QCIs feature.

show apn statistics all

The output of this command has been enhanced to show administrative disconnects and bearer statistics for the new standard QCIs 65, 66, 69, and 70. New statistics are highlighted in *italics*.

...

4G Bearers Released By Reasons:

	QCI1	QCI2	QCI3	QCI4	QCI5	QCI6	QCI7	QCI8	QCI9
Admin disconnect:	0	0	0	0	0	0	0	0	0

show gtpu statistics

```

Admin disconnect:      QCI65      QCI66      QCI69      QCI70
                       0          0          0          0
...

QCI 65:
  Bearer Active:      0      Bearer setup:      0
  Bearer Released:    0      Bearer Rejected:    0

  Uplink Bytes forwarded:      0      Downlink Bytes forwarded:      0
  Uplink pkts forwarded:      0      Downlink pkts forwarded:      0
  Uplink Bytes dropped:      0      Downlink Bytes dropped:      0
  Uplink pkts dropped:      0      Downlink pkts dropped:      0
  Uplink Bytes dropped(MBR Excd): 0      Downlink Bytes dropped(MBR Excd): 0
  Uplink pkts dropped(MBR Excd): 0      Downlink pkts dropped(MBR Excd): 0

QCI 66:
  Bearer Active:      0      Bearer setup:      0
  Bearer Released:    0      Bearer Rejected:    0

  Uplink Bytes forwarded:      0      Downlink Bytes forwarded:      0
  Uplink pkts forwarded:      0      Downlink pkts forwarded:      0
  Uplink Bytes dropped:      0      Downlink Bytes dropped:      0
  Uplink pkts dropped:      0      Downlink pkts dropped:      0
  Uplink Bytes dropped(MBR Excd): 0      Downlink Bytes dropped(MBR Excd): 0
  Uplink pkts dropped(MBR Excd): 0      Downlink pkts dropped(MBR Excd): 0

QCI 69:
  Bearer Active:      0      Bearer setup:      0
  Bearer Released:    0      Bearer Rejected:    0

  Uplink Bytes forwarded:      0      Downlink Bytes forwarded:      0
  Uplink pkts forwarded:      0      Downlink pkts forwarded:      0
  Uplink Bytes dropped:      0      Downlink Bytes dropped:      0
  Uplink pkts dropped:      0      Downlink pkts dropped:      0
  Uplink Bytes dropped(MBR Excd): 0      Downlink Bytes dropped(MBR Excd): 0
  Uplink pkts dropped(MBR Excd): 0      Downlink pkts dropped(MBR Excd): 0

QCI 70:
  Bearer Active:      0      Bearer setup:      0
  Bearer Released:    0      Bearer Rejected:    0

  Uplink Bytes forwarded:      0      Downlink Bytes forwarded:      0
  Uplink pkts forwarded:      0      Downlink pkts forwarded:      0
  Uplink Bytes dropped:      0      Downlink Bytes dropped:      0
  Uplink pkts dropped:      0      Downlink pkts dropped:      0
  Uplink Bytes dropped(MBR Excd): 0      Downlink Bytes dropped(MBR Excd): 0
  Uplink pkts dropped(MBR Excd): 0      Downlink pkts dropped(MBR Excd): 0
                                     0
...

```

show gtpu statistics

The output of this command has been enhanced to provide packet and byte information for QCI values 65, 66, 69, and 70. New statistics are in *italics*.

```

...
QCI 9:
  Uplink Packets:      0      Uplink Bytes:      0
  Downlink Packets:    0      Downlink Bytes:    0
  Packets Discarded:   0      Bytes Discarded:   0

QCI 65:
  Uplink Packets:      0      Uplink Bytes:      0

```

```

Downlink Packets:          0 Downlink Bytes:          0
Packets Discarded:        0 Bytes Discarded:          0

QCI 66:
Uplink Packets:           0 Uplink Bytes:           0
Downlink Packets:         0 Downlink Bytes:         0
Packets Discarded:        0 Bytes Discarded:          0

QCI 69:
Uplink Packets:           0 Uplink Bytes:           0
Downlink Packets:         0 Downlink Bytes:         0
Packets Discarded:        0 Bytes Discarded:          0

QCI 70:
Uplink Packets:           0 Uplink Bytes:           0
Downlink Packets:         0 Downlink Bytes:         0
Packets Discarded:        0 Bytes Discarded:          0

Non-Std QCI (Non-GBR):
Uplink Packets:           0 Uplink Bytes:           0
Downlink Packets:         0 Downlink Bytes:         0
Packets Discarded:        0 Bytes Discarded:          0
...

```

show pgw-service statistics all verbose

The output of this command has been enhanced to provide new standard QCI information by QoS characteristics and IPv4v6 PDN Data statistics. New statistics are in *italics*.

Bearers By QoS characteristics:

```

Active:
QCI 1:                      0      Setup:
QCI 1:                      0      QCI 1:                      0
...
QCI 65:                   0      QCI 65:                   0
QCI 66:                   0      QCI 66:                   0
QCI 69:                   0      QCI 69:                   0
QCI 70:                   0      QCI 70:                   0
...

```

Released:

```

QCI 1:                      0
...
QCI 65:                   0
QCI 66:                   0
QCI 69:                   0
QCI 70:                   0
...

```

IPv4v6 PDN Data Statistics:

```

Uplink :
Packets:
QCI 1:                      0
...
QCI 65:                   0
QCI 66:                   0
QCI 69:                   0
QCI 70:                   0

Downlink :
Packets:
QCI 1:                      0
...
QCI 65:                   0
QCI 66:                   0
QCI 69:                   0
QCI 70:                   0

```

```
show saegw-service statistics all verbose
```

show saegw-service statistics all verbose

The output of this command has been enhanced to provide information related to the new standard QCIs. New statistics are in *italics>*.

```
...
Bearers By QoS characteristics:
  Active:
    QCI 1: 0
    ...
    QCI 9: 0
    QCI 65: 0
    QCI 66: 0
    QCI 69: 0
    QCI 70: 0
    Non-Std QCI: 0
  Released:
    QCI 1: 0
    ...
    QCI 9: 0
    QCI 65: 0
    QCI 66: 0
    QCI 69: 0
    QCI 70: 0
    Non-Std QCI: 0

...
    Std QCI (Non-GBR): 0
    Std QCI (GBR): 0

  Uplink :
    Packets:
      QCI 1: 0
      ...
      QCI 65: 0
      QCI 66: 0
      QCI 69: 0
      QCI 70: 0
      Non-Std QCI: 0
    Bytes:
      QCI 1: 0
      ...
      QCI 65: 0
      QCI 66: 0
      QCI 69: 0
      QCI 70: 0
      Non-Std QCI: 0
    Dropped Packets:
      QCI 1: 0
      ...
      QCI 65: 0
      QCI 66: 0
      QCI 69: 0
      QCI 70: 0
      Non-Std QCI: 0
    Dropped Bytes:
      QCI 1: 0
      ...
      QCI 65: 0
      QCI 66: 0

  Downlink :
    Packets:
      QCI 1: 0
      ...
      QCI 65: 0
      QCI 66: 0
      QCI 69: 0
      QCI 70: 0
      Non-Std QCI: 0
    Bytes:
      QCI 1: 0
      ...
      QCI 65: 0
      QCI 66: 0
      QCI 69: 0
      QCI 70: 0
      Non-Std QCI: 0
    Dropped Packets:
      QCI 1: 0\
      ...
      QCI 65: 0
      QCI 66: 0
      QCI 69: 0
      QCI 70: 0
      Non-Std QCI: 0
    Dropped Bytes:
      QCI 1: 0
      ...
      QCI 65: 0
      QCI 66: 0
```



```

          QCI 69:                0          QCI 69:                0
          QCI 70:                0          QCI 70:                0
          Non-Std QCI:           0          Non-Std QCI:           0
Setup Guard Timer Expired:      0

```

show sgw-service statistics all verbose

The output of this command has been enhanced to provide new standard QCI information. New statistics are highlighted in *italics>*.

```

...
Bearers By QoS characteristics:
  Active:
    QCI 1:                0          Setup:
    QCI 1:                0          QCI 1:                0
  ...
    QCI 65:               0          QCI 65:               0
    QCI 66:               0          QCI 66:               0
    QCI 69:               0          QCI 69:               0
    QCI 70:               0          QCI 70:               0
  ...
  Released:
    QCI 1:                0          Modified:
    QCI 1:                0          QCI 1:                0
  ...
    QCI 65:               0          QCI 65:               0
    QCI 66:               0          QCI 66:               0
    QCI 69:               0          QCI 69:               0
    QCI 70:               0          QCI 70:               0
  ...
Dedicated Bearers Released By Reason:
  PGW Ini:                0          PCRF Ini:              0
  QCI 1:                  0
  ...
    QCI 65:               0
    QCI 66:               0
    QCI 69:               0
    QCI 70:               0
    Non-Std QCI:         0
  ...
  S1 Error Ind:          0          S5 Error Ind:          0
  QCI 1:                  0          QCI 1:                  0
  ...
    QCI 65:               0          QCI 65:               0
    QCI 66:               0          QCI 66:               0
    QCI 69:               0          QCI 69:               0
    QCI 70:               0          QCI 70:               0
    Non-Std QCI:         0          Non-Std QCI:          0
  ...
  S4 Error Ind:          0          S12 Error Ind:         0
  QCI 1:                  0          QCI 1:                  0
  ...
    QCI 65:               0          QCI 65:               0
    QCI 66:               0          QCI 66:               0
    QCI 69:               0          QCI 69:               0
    QCI 70:               0          QCI 70:               0
    Non-Std QCI:         0          Non-Std QCI:          0
  ...
  Local:                  0          PDN Down:              0
  QCI 1:                  0          QCI 1:                  0
  ...
    QCI 65:               0          QCI 65:               0
    QCI 66:               0          QCI 66:               0

```

show sgw-service statistics all verbose

```

QCI 69: 0 QCI 69: 0
QCI 70: 0 QCI 70: 0
Non-Std QCI: 0 Non-Std QCI: 0

Path Failure S1-U: 0 Path Failure S5-U: 0
QCI 1: 0 QCI 1: 0
...
QCI 65: 0 QCI 65: 0
QCI 66: 0 QCI 66: 0
QCI 69: 0 QCI 69: 0
QCI 70: 0 QCI 70: 0
Non-Std QCI: 0 Non-Std QCI: 0

Path Failure S5: 0 Path Failure S11: 0
QCI 1: 0 QCI 1: 0
...
QCI 65: 0 QCI 65: 0
QCI 66: 0 QCI 66: 0
QCI 69: 0 QCI 69: 0
QCI 70: 0 QCI 70: 0
Non-Std QCI: 0 Non-Std QCI: 0

Path Failure S4-U: 0 Path Failure S12: 0
QCI 1: 0 QCI 1: 0
...
QCI 65: 0 QCI 65: 0
QCI 66: 0 QCI 66: 0
QCI 69: 0 QCI 69: 0
QCI 70: 0 QCI 70: 0
Non-Std QCI: 0 Non-Std QCI: 0

Inactivity Timeout: 0 Other: 0
QCI 1: 0 QCI 1: 0
...
QCI 65: 0 QCI 65: 0
QCI 66: 0 QCI 66: 0
QCI 69: 0 QCI 69: 0
QCI 70: 0 QCI 70: 0
Non-Std QCI: 0 Non-Std QCI: 0

...
Data Statistics Per Interface:
S1-U Total Data Statistics:
Uplink : Downlink :
...
Packets: Packets:
QCI 1: 0 QCI 1: 0
...
QCI 65: 0 QCI 65: 0
QCI 66: 0 QCI 66: 0
QCI 69: 0 QCI 69: 0
QCI 70: 0 QCI 70: 0
Non-Std QCI: 0 Non-Std QCI: 0

Bytes: Bytes:
QCI 1: 0 QCI 1: 0
...
QCI 65: 0 QCI 65: 0
QCI 66: 0 QCI 66: 0
QCI 69: 0 QCI 69: 0
QCI 70: 0 QCI 70: 0
Non-Std QCI: 0 Non-Std QCI: 0

Dropped Packets: Dropped Packets:

```

```

...
    QCI 1: 0 QCI 1: 0
...
    QCI 65: 0 QCI 65: 0
    QCI 66: 0 QCI 66: 0
    QCI 69: 0 QCI 69: 0
    QCI 70: 0 QCI 70: 0
    Non-Std QCI: 0 Non-Std QCI: 0

    Dropped Bytes:
    QCI 1: 0 QCI 1: 0
...
    QCI 65: 0 QCI 65: 0
    QCI 66: 0 QCI 66: 0
    QCI 69: 0 QCI 69: 0
    QCI 70: 0 QCI 70: 0
    Non-Std QCI: 0 Non-Std QCI: 0

S4-U Total Data Statistics:
Uplink :
    Total Pkts: 0
    Total Bytes: 0
    Dropped Pkts: 0
    Dropped Bytes: 0

Packets:
    QCI 1: 0
...
    QCI 65: 0
    QCI 66: 0
    QCI 69: 0
    QCI 70: 0
    Non-Std QCI: 0

Bytes:
    QCI 1: 0
...
    QCI 65: 0
    QCI 66: 0
    QCI 69: 0
    QCI 70: 0
    Non-Std QCI: 0

Dropped Packets:
    QCI 1: 0
...
    QCI 65: 0
    QCI 66: 0
    QCI 69: 0
    QCI 70: 0
    Non-Std QCI: 0

Dropped Bytes:
    QCI 1: 0
...
    QCI 65: 0
    QCI 66: 0
    QCI 69: 0
    QCI 70: 0
    Non-Std QCI: 0

S12 Total Data Statistics:
Uplink :
    Total Pkts: 0
    Total Bytes: 0

Downlink :
    Total Pkts: 0
    Total Bytes: 0

```

show sgw-service statistics all verbose

```

Dropped Pkts:                0      Dropped Pkts:                0
Dropped Bytes:               0      Dropped Bytes:               0

Packets:                     0      Packets:                     0
  QCI 1:                     0      QCI 1:                     0
...
  QCI 65:                    0      QCI 65:                    0
  QCI 66:                    0      QCI 66:                    0
  QCI 69:                    0      QCI 69:                    0
  QCI 70:                    0      QCI 70:                    0
  Non-Std QCI:              0      Non-Std QCI:              0

Bytes:                       0      Bytes:                       0
  QCI 1:                     0      QCI 1:                     0
...
  QCI 65:                    0      QCI 65:                    0
  QCI 66:                    0      QCI 66:                    0
  QCI 69:                    0      QCI 69:                    0
  QCI 70:                    0      QCI 70:                    0
  Non-Std QCI:              0      Non-Std QCI:              0

Dropped Packets:            0      Dropped Packets:            0
  QCI 1:                     0      QCI 1:                     0
...
  QCI 65:                    0      QCI 65:                    0
  QCI 66:                    0      QCI 66:                    0
  QCI 69:                    0      QCI 69:                    0
  QCI 70:                    0      QCI 70:                    0
  Non-Std QCI:              0      Non-Std QCI:              0

Dropped Bytes:             0      Dropped Bytes:             0
  QCI 1:                     0      QCI 1:                     0
...
  QCI 65:                    0      QCI 65:                    0
  QCI 66:                    0      QCI 66:                    0
  QCI 69:                    0      QCI 69:                    0
  QCI 70:                    0      QCI 70:                    0
  Non-Std QCI:              0      Non-Std QCI:              0

S5-U Total Data Statistics:
Uplink :                    Downlink :
Total Pkts:                 0      Total Pkts:                 0
Total Bytes:                0      Total Bytes:                0
Dropped Pkts:              0      Dropped Pkts:              0
Dropped Bytes:             0      Dropped Bytes:             0

Packets:                   0      Packets:                   0
  QCI 1:                   0      QCI 1:                   0
...
  QCI 65:                  0      QCI 65:                  0
  QCI 66:                  0      QCI 66:                  0
  QCI 69:                  0      QCI 69:                  0
  QCI 70:                  0      QCI 70:                  0
  Non-Std QCI:            0      Non-Std QCI:            0

Bytes:                     0      Bytes:                     0
  QCI 1:                   0      QCI 1:                   0
...
  QCI 65:                  0      QCI 65:                  0
  QCI 66:                  0      QCI 66:                  0
  QCI 69:                  0      QCI 69:                  0
  QCI 70:                  0      QCI 70:                  0
  Non-Std QCI:            0      Non-Std QCI:            0

```

```

Dropped Packets:
  QCI 1: 0
...
  QCI 65: 0
  QCI 66: 0
  QCI 69: 0
  QCI 70: 0
  Non-Std QCI: 0

Dropped Bytes:
  QCI 1: 0
...
  QCI 65: 0
  QCI 66: 0
  QCI 69: 0
  QCI 70: 0
  Non-Std QCI: 0

S8-U Total Data Statistics:
Uplink :
  Total Pkts: 0
  Total Bytes: 0
  Dropped Pkts: 0
  Dropped Bytes: 0

Packets:
  QCI 1: 0
...
  QCI 65: 0
  QCI 66: 0
  QCI 69: 0
  QCI 70: 0
  Non-Std QCI: 0

Bytes:
  QCI 1: 0
...
  QCI 65: 0
  QCI 66: 0
  QCI 69: 0
  QCI 70: 0
  Non-Std QCI: 0

Dropped Packets:
  QCI 1: 0
...
  QCI 65: 0
  QCI 66: 0
  QCI 69: 0
  QCI 70: 0
  Non-Std QCI: 0

Dropped Bytes:
  QCI 1: 0
...
  QCI 65: 0
  QCI 66: 0
  QCI 69: 0
  QCI 70: 0
  Non-Std QCI: 0

Downlink :
  Total Pkts: 0
  Total Bytes: 0
  Dropped Pkts: 0
  Dropped Bytes: 0

Packets:
  QCI 1: 0
...
  QCI 65: 0
  QCI 66: 0
  QCI 69: 0
  QCI 70: 0
  Non-Std QCI: 0

Bytes:
  QCI 1: 0
...
  QCI 65: 0
  QCI 66: 0
  QCI 69: 0
  QCI 70: 0
  Non-Std QCI: 0

Dropped Packets:
  QCI 1: 0
...
  QCI 65: 0
  QCI 66: 0
  QCI 69: 0
  QCI 70: 0
  Non-Std QCI: 0

Dropped Bytes:
  QCI 1: 0
...
  QCI 65: 0
  QCI 66: 0
  QCI 69: 0
  QCI 70: 0
  Non-Std QCI: 0

```

Non-standard QCI Support

This section describes the Non-standard QCI Support feature.

Feature Description

Usually, only standards-based QCI values of 1 through 9 are supported on GGSN/P-GW/SAEGW/S-GW/ePDG. A license, however, allows non-standard QCIs (128-254) to be used on P-GW/GGSN (not standalone GGSN).

Licensing

Use of non-standard QCIs require that a valid license key be installed. Contact your Cisco Account or Support representative for information on how to obtain a license.

How It Works

From 3GPP Release 8 onwards, operator-specific/non-standard QCIs can be supported and carriers can define QCI 128-254. QCI values 0 and 10 to 255 are defined as follows:

- 0: Reserved
- 10-127: Reserved
- 128-254: Operator-specific/Non-standard QCI
- 255: Reserved

Unique operator-specific QCIs (128-254) can be used to differentiate between various services/applications carriers provide to the end users in their network.

Limitations

- Non-standard QCIs can only be supported with S5/S8/S2a/S2b interfaces.
- The Gn interface is not supported.

Standards Compliance

- 3GPP Specification TS 23.203: Policy and charging control architecture
- 3GPP Specification TS 29.212: Policy and Charging Control over Gx reference point

Configuring Non-standard QCI Support

The **operator-defined-qci** command in the QCI-QoS Mapping Configuration Mode configures the non-standard QCIs in P-GW so that calls can be accepted when non-standard QCI values are received from UE or PCRF. Unique DSCP parameters (uplink and downlink) and GBR or Non-GBR can also be configured.

As non-standard QCIs are not supported in GGSN, **pre-rel8-qos-mapping** is used as a reference for mapping the non-standard QCI values to pre-rel8 QoS values during 3G calls or GnGp handovers.

Configuring Non-standard QCI Support in P-GW

Use the following command to configure non-standard QCI support in P-GW so that calls can be accepted when non-standard QCI values are received from UE or PCRF.

```
configure
  qci-qos-mapping name
    operator-defined-qci num { gbr | non-gbr } [ { downlink |
uplink } [ encaps-header { copy-inner | copy-outer | dscp-marking
dscp-marking-value } [ internal-qos priority priority ] | internal-qos priority
priority | user-datagram dscp-marking dscp-marking-value [ encaps-header {
copy-inner | copy-outer | dscp-marking dscp-marking-value } [ internal-qos
priority priority ] ] ] | pre-rel8-qos-mapping num ]
    no operator-defined-qci num
  end
```

Notes:

- This command is only visible if the license key supporting non-standard QCIs is installed. Contact your Cisco Account or Support representative for information on how to obtain a license.

- **operator-defined-qci num**: Specifies the operator-defined QCI value to be enabled.

num must be an integer from 128 through 254.

Standards-based QCI values 1 through 9 are configured through the **qci** command.

- **pre-rel8-qos-mapping num**: Maps non-standard QCI to a standard QCI that has the characteristics (TC, THP, SI, TD, SSD) similar to desired pre-rel8 standard QoS values during 3G call or GnGp handover.

num must be an integer from 1 through 4 for GBR and 5 through 9 for non-GBR. QCI values 1 through 9 are defined in *3GPP Specification TS 23.203 "Policy and charging control architecture"*.

3G GGSN Call

If the **pre-rel8-qos-mapping** field is not configured for the non-standard QCI under P-GW which is associated with a GGSN, then the 3G call would be rejected.

GnGp Handoff

1. If the **pre-rel8-qos-mapping** field is not configured for the non-standard QCI for default bearer, then the handoff would be rejected.
2. If the **pre-rel8-qos-mapping** field is not configured for the non-standard QCI for dedicated bearer, then only that bearer would be rejected during handoff.
3. In the following scenario:
 - default bearer with standard QCI or non-standard QCI (with **pre-rel8-qos-mapping** configured)
 - more than one dedicated bearer (some with standard QCI, some with non-standard QCI with **pre-rel8-qos-mapping** configured, and some with non-standard QCI with no mapping)

During LTE-to-GnGp handoff:

- UPC Request for all the dedicated bearers with non-standard QCI with no mapping would be rejected
- handoff will be successful for the remaining bearers

Monitoring Non-standard QCI Support

Bulk Statistics

This section provides information regarding bulk statistics in support of non-standard QCI support.

APN Schema

The following counters have been added in support of non-standard QCIs (GBR and Non-GBR):

- nonstdqci-nongbr-uplinkpkt-drop-mbrexcd
- nonstdqci-nongbr-dwlinkpkt-drop-mbrexcd
- nonstdqci-nongbr-uplinkbyte-drop-mbrexcd
- nonstdqci-nongbr-dwlinkbyte-drop-mbrexcd
- nonstdqci-nongbr-rejbearer
- nonstdqci-gbr-uplinkpkt-drop-mbrexcd
- nonstdqci-gbr-dwlinkpkt-drop-mbrexcd
- nonstdqci-gbr-uplinkbyte-drop-mbrexcd
- nonstdqci-gbr-dwlinkbyte-drop-mbrexcd
- nonstdqci-gbr-rejbearer

Output of Show Commands

This section provides information regarding show commands and/or their outputs in support of non-standard QCI support.

show apn statistics

The output of this command has been enhanced to show the following non-standard QCI counters (GBR and Non-GBR):

- Non-Std QCI(Non-GBR)
 - Bearer Rejected
 - Uplink Bytes dropped(MBR Excd)
 - Downlink Bytes dropped(MBR Excd)
 - Uplink pkts dropped(MBR Excd)
 - Downlink pkts dropped(MBR Excd)
- Non-Std QCI(GBR)
 - Bearer Rejected
 - Uplink Bytes dropped(MBR Excd)
 - Downlink Bytes dropped(MBR Excd)
 - Uplink pkts dropped(MBR Excd)
 - Downlink pkts dropped(MBR Excd)

show qci-qos-mapping table all

The output of this command has been enhanced to show when non-standard QCI are configured:

- Operator-defined-qci
- pre-rel8-qos-mapping



CHAPTER 19

GGSN UPC Collision Handling

- [GGSN UPC Collision Handling, on page 425](#)

GGSN UPC Collision Handling

Feature Description

During collision between SGSN-initiated UPC request and GGSN-initiated UPC Request, SGSN-initiated UPC request gets higher priority over Network Operated (NRUPC). With the UPC Collision Handling feature, there is no call or data loss during call establishment or during mid-call phase. This feature can be enabled or disabled using a CLI and is enabled by default.

- When GGSN detects collision between SGSN initiated UPC request and NRUPC on primary PDP context, NRUPC is retried (with different sequence number) after sending UPC Response.
- When GGSN detects collision between SGSN initiated UPC request for Inter-SGSN handoff and NRUPC with TFT and after handoff BCM mode is changed from Mixed mode to MS-Only mode, NRUPC is retried (with different sequence number) after sending UPC Response, but without TFT.
- When GGSN detects collision between an SGSN initiated UPC and a NRUPC on secondary PDP context, NRUPC is aborted and PCRF is notified. When multiple CCR-U support is not enabled on GGSN, CCR-U for aborted NRUPC (on secondary PDP context) is not informed to PCRF. In this case, PCRF will not be aware of this aborted transaction (rule failure).



Note During S2bGTP to LTE handoff procedure, when there is already a pending transaction and a Handoff request is received by SAE-GW, Handoff is rejected with a following message:

```
Rejecting S2b/LTE Handoff as only one pending transaction is supported
```

Limitations

- Behavior for GnGp GGSN has been modified for this feature, in this release. Behavior for GGSN remains unaltered.

- When NRUPC received from Direct Tunnel (due to "Direct Tunnel Error Indication") collides with SGSN initiated UPC request, NRUPC is aborted and not retried. This does not affect the functionality as, when "Direct Tunnel Error Indication" is received from access side, NRUPC is triggered again.
- When a request for handoff to LTE is received before receiving NRUPC response, the behavior remains unchanged. In this case, the pending NRUPC request is aborted. If the NRUPC request received is for rule installation, the request remains in the pending state and the rule is not installed. As there is no static rule and the rule installation request is in pending state, the PDP context stays up without an installed rule.

Configuring GGSN UPC Collision Handling

Operators can use the Command Line Interface (CLI) to configure the collision between SGSN initiated UPC request and network initiated UPC Request.

gtpc handle-collision

This command in the service configuration mode can be used to the collision between SGSN initiated UPC request and network initiated UPC Request.

GGSN Service

```
configure
  context context_name
    ggsn-service service_name
      [ no | default ] gtpc handle-collision upc nrupc
    end
```

P-GW Service

```
configure
  context context_name
    pgw-service service_name
      [ no | default ] gtpc handle-collision upc nrupc
    end
```

S-GW Service

```
configure
  context context_name
    sgw-service service_name
      [ no | default ] gtpc handle-collision upc nrupc
    end
```

SAEGW Service

```
configure
  context context_name
    saegw-service service_name
      [ no | default ] gtpc handle-collision upc nrupc
    end
```

Notes:

- **no:** Disables collision handling between SGSN initiated UPC and NRUPC request.

- **default:** Sets default collision handling behavior between SGSN initiated UPC and NRUPC request. By default, collision handling is enabled.
- **handle-collision upc nrupc:** Enables/Disables collision handling between SGSN initiated UPC and network requested UPC. By default, collision handling is enabled.

Verifying the Configuration

The configuration of this feature can be verified using the following commands from the `exec` mode:

- **show configuration**
- **show configuration verbose**

Please see the *Monitoring and Troubleshooting GGSN UPC Collision Handling* section for the command output.

Monitoring and Troubleshooting GGSN UPC Collision Handling

The following section describes commands available to monitor GGSN UPC Collision Handling.

Show Commands for GGSN UPC Collision Handling

show configuration

This command displays the following output:

```
ggsn-service ggsn-service
associate gtpu-service gtpu-service
associate pgw-service pgw_service
associate peer-map map_ggsn

no gtpc handle-collision upc nrupc
```

show configuration verbose

This command displays the following output:

```
ggsn-service ggsn-service
associate gtpu-service gtpu-service
associate pgw-service pgw_service
associate peer-map map_ggsn

no gtpc handle-collision upc nrupc
```

show ggsn-service name *service_name*

This command displays the following output:

```
Service name:                ggsn-service
Context:                    ingress
...
Suppress NRUPC triggered by UPC: Disabled
```

show gtpc statistics

Collision handling for UPC-NRUPC: Enabled/Disabled

show gtpc statistics

This command displays the number of NRUPC and SGSN initiated UPC collisions happening for primary and secondary PDP context for a GGSN service. This command displays the following output:

```
Active Subscribers:
  Total:                1
  2G:                   0
  3G:                   1
...
...
MS Info Change Reporting Messages:
  MS Info Chng Notif Req:  0   Accepted:                0
  Denied:                  0   Discarded:                0

NRUPC UPC Collision:
  Primary PDP ctxt:       3   Secondary PDP ctxt:       0

QoS negotiation:
  CPC QoS Accepted:       3   CPC QoS Downgraded:       0
  UPC QoS Accepted:       3   UPC QoS Downgraded:       0
```

show gtpc statistics [format1 | ggsn-service *service_name* | verbose]

This command displays the number of NRUPC and SGSN initiated UPC collisions happening for primary and secondary PDP context for a GGSN service. This command displays the following output:

```
Active Subscribers:
  Total:                1
  2G:                   0
  3G:                   1
...
...
MS Info Change Reporting Messages:
  MS Info Chng Notif Req:  0   Accepted:                0
  Denied:                  0   Discarded:                0

NRUPC UPC Collision:
  Primary PDP ctxt:       3   Secondary PDP ctxt:       0

QoS negotiation:
  CPC QoS Accepted:       3   CPC QoS Downgraded:       0
  UPC QoS Accepted:       3   UPC QoS Downgraded:       0
```



CHAPTER 20

GRE Protocol Interface

This chapter provides information on Generic Routing Encapsulation protocol interface support in the GGSN or P-GW service node. The product Administration Guides provide examples and procedures for configuration of basic services on the system. It is recommended that you select the configuration example that best meets your service model, and configure the required elements for that model, as described in the respective product Administration Guide, before using the procedures in this chapter.



Important GRE protocol interface support is a licensed Cisco feature. A separate feature license may be required. Contact your Cisco account representative for detailed information on specific licensing requirements. For information on installing and verifying licenses, refer to the *Managing License Keys* section of the *Software Management Operations* chapter in the *System Administration Guide*.



Important Commands used in the configuration samples in this section provide base functionality to the extent that the most common or likely commands and/or keyword options are presented. In many cases, other optional commands and/or keyword options are available. Refer to the *Command Line Interface Reference* for complete information regarding all commands.

- [Introduction, on page 429](#)
- [Supported Standards, on page 430](#)
- [Supported Networks and Platforms, on page 431](#)
- [Licenses, on page 431](#)
- [Services and Application on GRE Interface, on page 431](#)
- [How GRE Interface Support Works, on page 431](#)
- [GRE Interface Configuration, on page 434](#)
- [Verifying Your Configuration, on page 437](#)

Introduction

GRE protocol functionality adds one additional protocol on Cisco's multimedia core platforms (ASR 5500 or higher) to support mobile users to connect to their enterprise networks through Generic Routing Encapsulation (GRE).

GRE tunnels can be used by the enterprise customers of a carrier 1) To transport AAA packets corresponding to an APN over a GRE tunnel to the corporate AAA servers and, 2) To transport the enterprise subscriber packets over the GRE tunnel to the corporation gateway.

The corporate servers may have private IP addresses and hence the addresses belonging to different enterprises may be overlapping. Each enterprise needs to be in a unique virtual routing domain, known as VRF. To differentiate the tunnels between same set of local and remote ends, GRE Key will be used as a differentiator.

It is a common technique to enable multi-protocol local networks over a single-protocol backbone, to connect non-contiguous networks and allow virtual private networks across WANs. This mechanism encapsulates data packets from one protocol inside a different protocol and transports the data packets unchanged across a foreign network. It is important to note that GRE tunneling does not provide security to the encapsulated protocol, as there is no encryption involved (like IPSEC offers, for example).

GRE Tunneling consists of three main components:

- Passenger protocol-protocol being encapsulated. For example: CLNS, IPv4 and IPv6.
- Carrier protocol-protocol that does the encapsulating. For example: GRE, IP-in-IP, L2TP, MPLS and IPSec.
- Transport protocol-protocol used to carry the encapsulated protocol. The main transport protocol is IP.

The most simplified form of the deployment scenario is shown in the following figure, in which GGSN has two APNs talking to two corporate networks over GRE tunnels.

Figure 76: GRE Interface Deployment Scenario

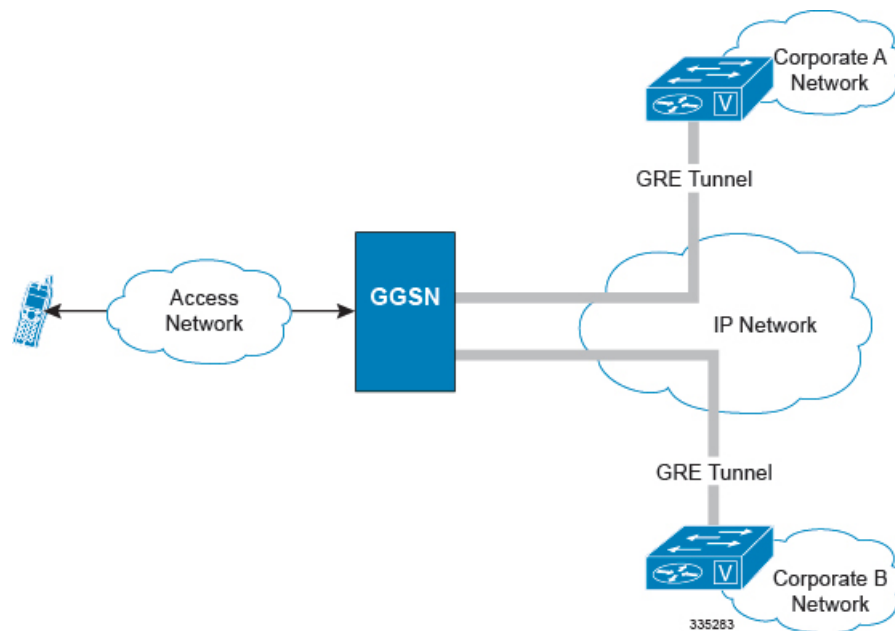

Supported Standards

Support for the following standards and requests for comments (RFCs) have been added with this interface support:

- RFC 1701, Generic Routing Encapsulation (GRE)
- RFC 1702, Generic Routing Encapsulation over IPv4 networks
- RFC 2784, Generic Routing Encapsulation (GRE)
- RFC 2890, Key and Sequence Number Extensions to GRE

Supported Networks and Platforms

This feature supports all systems with StarOS Release 9.0 or later running GGSN and/or SGSN service for the core network services. The P-GW service supports this feature with StarOS Release 12.0 or later.

Licenses

GRE protocol interface support is a licensed Cisco feature. A separate feature license may be required. Contact your Cisco account representative for detailed information on specific licensing requirements. For information on installing and verifying licenses, refer to the *Managing License Keys* section of the *Software Management Operations* chapter in the *System Administration Guide*.

Services and Application on GRE Interface

GRE interface implementation provides the following functionality with GRE protocol support.

How GRE Interface Support Works

The GRE interface provides two types of data processing; one for ingress packets and another for egress packets.

Ingress Packet Processing on GRE Interface

Figure given below provides a flow of process for incoming packets on GRE interface.

Note that in case the received packet is a GRE keep-alive or a ping packet then the outer IPV4 and GRE header are not stripped off (or get reattached), but instead the packet is forwarded as is to the VPN manager or kernel respectively. In case of all other GRE tunneled packets the IPV4 and GRE header are stripped off before sending the packet for a new flow lookup.

Figure 77: Ingress Packet Processing on GRE Interface

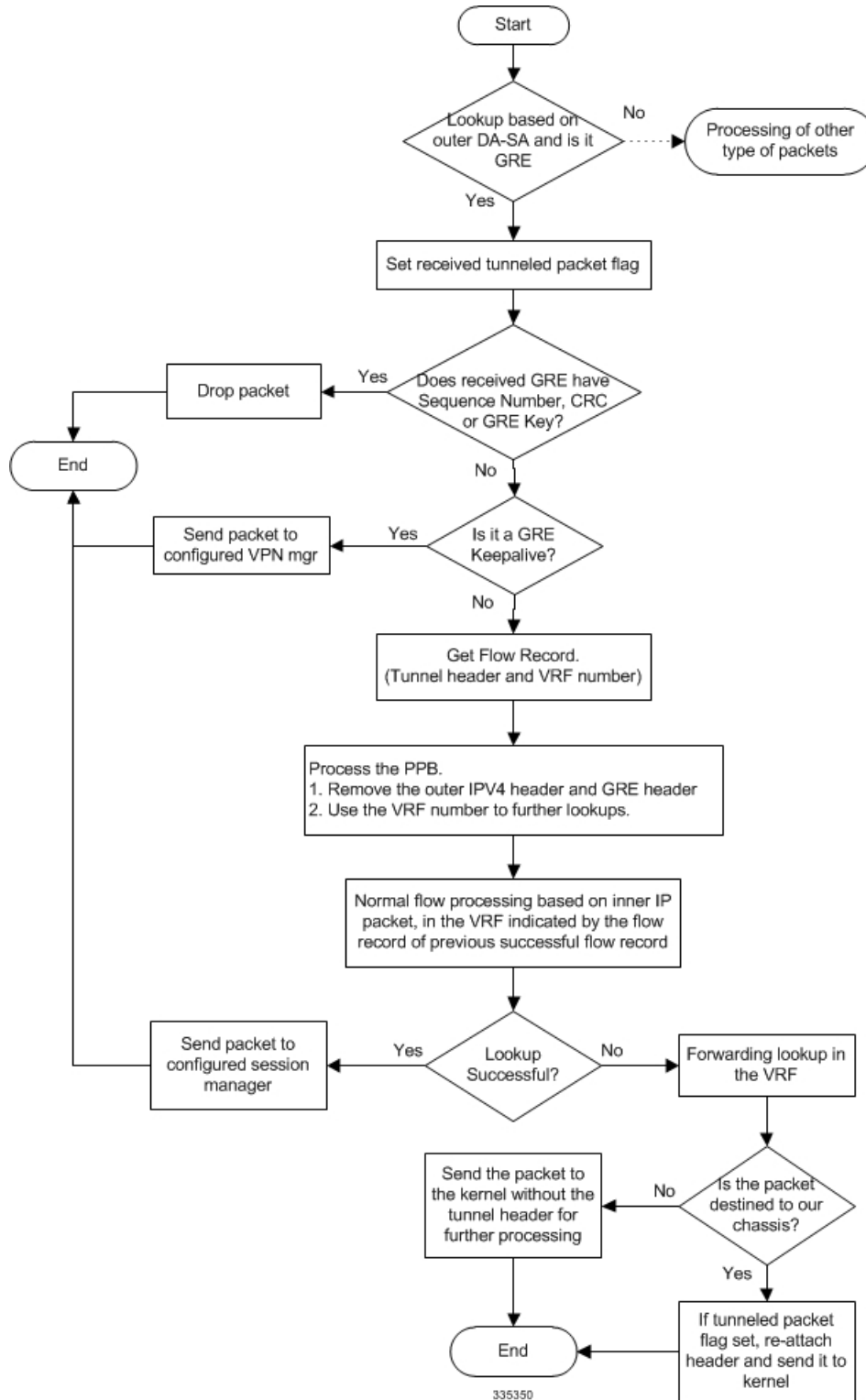

Egress Packet Processing on GRE Interface

Figure given below provides a flow of process for outgoing packets on GRE interface:

Figure 78: Egress Packet Processing on GRE Interface

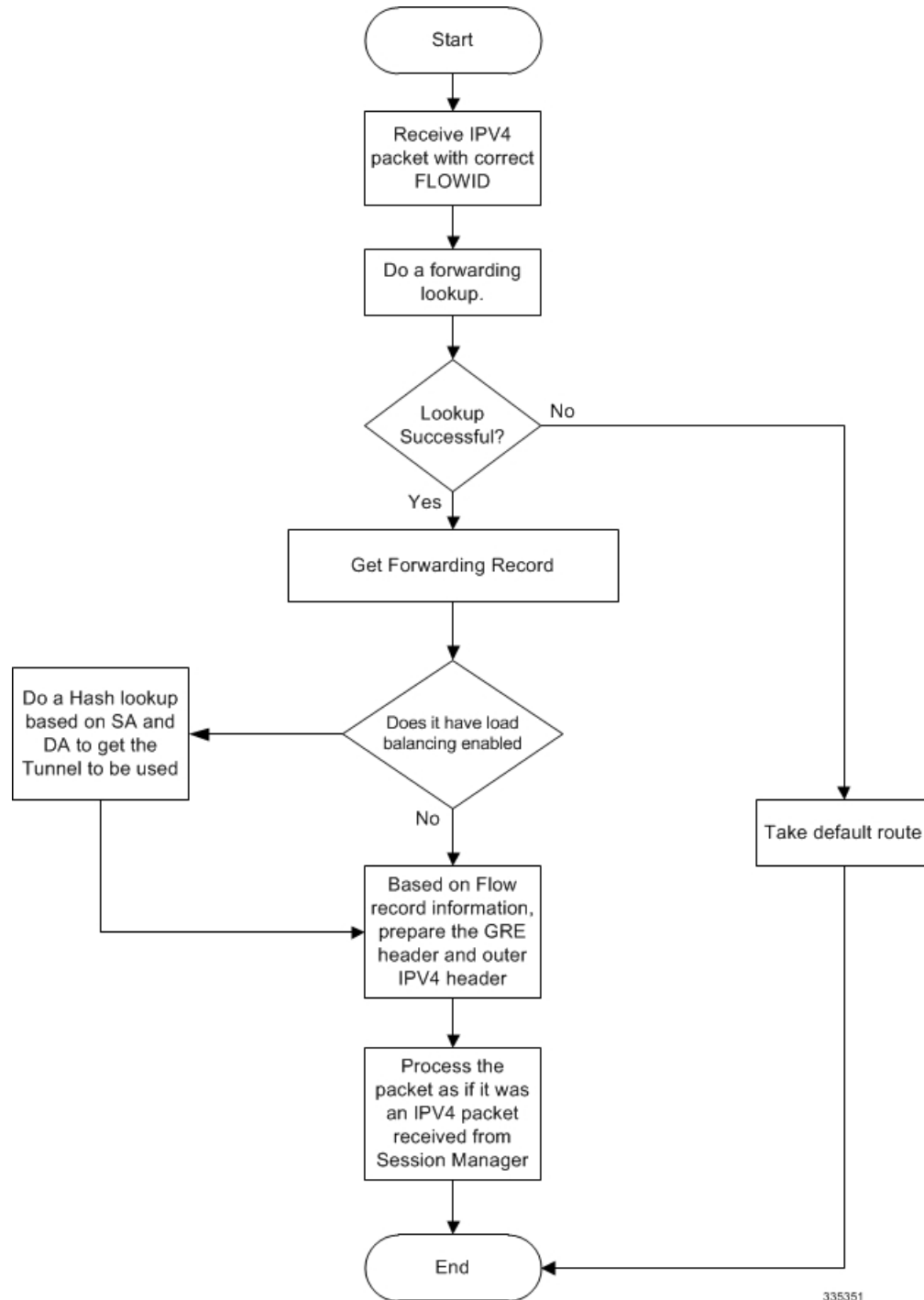

GRE Interface Configuration

This section provides a high-level series of steps and the associated configuration examples for configuring the system with GRE interface in GGSN or P-GW services.



Important This section provides the minimum instruction set to enable the GRE Protocol Interface support functionality on a GGSN or P-GW. Commands that configure additional functions for this feature are provided in the *Command Line Interface Reference*.

These instructions assume that you have already configured the system level configuration as described in *System Administration Guide* and specific product Administration Guide.

To configure the system to support GRE tunnel interface:

-
- Step 1** Configure the virtual routing and forwarding (VRF) in a context by applying the example configurations presented in [Virtual Routing And Forwarding \(VRF\) Configuration, on page 434](#).
 - Step 2** Configure the GRE tunnel interface in a context by applying the example configurations presented in [GRE Tunnel Interface Configuration, on page 435](#).
 - Step 3** Enable OSPF for the VRF and for the given network by applying the example configurations presented in [Enabling OSPF for VRF, on page 435](#).
 - Step 4** Associate IP pool and AAA server group with VRF by applying the example configurations presented in [Associating IP Pool and AAA Group with VRF, on page 436](#).
 - Step 5** Associate APN with VRF through AAA server group and IP pool by applying the example configurations presented in [Associating APN with VRF, on page 436](#).
 - Step 6** Optional. If the route to the server is not learnt from the corporate over OSPFv2, static route can be configured by applying the example configurations presented in [Static Route Configuration, on page 436](#).
 - Step 7** Save your configuration to flash memory, an external memory device, and/or a network location using the Exec mode command **save configuration**. For additional information on how to verify and save configuration files, refer to the *System Administration Guide* and the *Command Line Interface Reference*.
 - Step 8** Verify configuration of GRE and VRF related parameters by applying the commands provided in [Verifying Your Configuration, on page 437](#).
-

Virtual Routing And Forwarding (VRF) Configuration

This section provides the configuration example to configure the VRF in a context:

```
configure
  context <vpn_context_name> -noconfirm ]
    ip vrf <vrf_name>
      ip maximum-routes <max_routes>
    end
```

Notes:

- `<vpn_context_name>` is the name of the system context you want to use for VRF. For more information, refer *System Administration Guide*.
- A maximum of 300 VRFs per context and up to 2,048 VRFs per chassis can be configured on system.
- `<vrf_name>` is name of the VRF which is to be associated with various interfaces.
- A maximum of 10000 routes can be configured through **ip maximum-routes** `<max_routes>` command.

GRE Tunnel Interface Configuration

This section provides the configuration example to configure the GRE tunnel interface and associate a VRF with GRE interface:

```
configure
context <vpn_context_name>
  ip interface <intfc_name> tunnel
  ip vrf forwarding <vrf_name>
  ip address <internal_ip_address/mask>
  tunnel-mode gre
  source interface <non_tunn_intfc_to_corp>
  destination address <global_ip_address>
  keepalive interval <value> num-retry <retry>
end
```

Notes:

- `<vpn_context_name>` is the name of the system context you want to use for GRE interface configuration. For more information, refer *Command Line Interface Reference*.
- A maximum of 511 GRE tunnels + 1 non-tunnel interface can be configured in one context. System needs at least 1 non-tunnel interface as a default.
- `<intfc_name>` is name of the IP interface which is defined as a tunnel type interface and to be used for GRE tunnel interface.
- `<vrf_name>` is the name of the VRF which is preconfigured in context configuration mode.
- `<internal_ip_address/mask>` is the network IP address with sub-net mask to be used for VRF forwarding.
- `<non_tunn_intfc_to_corp>` is the name a non-tunnel interface which is required by system as source interface and preconfigured. For more information on interface configuration refer *System Administration Guide*.
- `<global_ip_address>` is a globally reachable IP address to be used as a destination address.

Enabling OSPF for VRF

This section provides the configuration example to enable the OSPF for VRF to support GRE tunnel interface:

```
configure
context <vpn_context_name>
  router ospf
  ip vrf <vrf_name>
  network <internal_ip_address/mask>
end
```

Notes:

- `<vpn_context_name>` is the name of the system context you want to use for OSPF routing. For more information, refer *Routing* in this guide.

- `<vrf_name>` is the name of the VRF which is preconfigured in context configuration mode.
- `<internal_ip_address/mask>` is the network IP address with sub-net mask to be used for OSPF routing.

Associating IP Pool and AAA Group with VRF

This section provides the configuration example for associating IP pool and AAA groups with VRF:

```
configure
  context <vpn_context_name>
    ip pool <ip_pool_name> <internal_ip_address/mask> vrf <vrf_name>
    exit
  aaa group <aaa_server_group>
    ip vrf <vrf_name>
  end
```

Notes:

- `<vpn_context_name>` is the name of the system context you want to use for IP pool and AAA server group.
- `<ip_pool_name>` is name of a preconfigured IP pool. For more information refer *System Administration Guide*.
- `<aaa_server_group>` is name of a preconfigured AAA server group. For more information refer *AAA Interface Administration and Reference*.
- `<vrf_name>` is the name of the VRF which is preconfigured in context configuration mode.
- `<internal_ip_address/mask>` is the network IP address with sub-net mask to be used for IP pool.

Associating APN with VRF

This section provides the configuration example for associating an APN with VRF through AAA group and IP pool:

```
configure
  context <vpn_context_name>
    apn <apn_name>
    aaa group <aaa_server_group>
    ip address pool name <ip_pool_name>
  end
```

Notes:

- `<vpn_context_name>` is the name of the system context you want to use for APN configuration.
- `<ip_pool_name>` is name of a preconfigured IP pool. For more information refer *System Administration Guide*.
- `<aaa_server_group>` is name of a preconfigured AAA server group. For more information refer *AAA Interface Administration and Reference*.
- `<vrf_name>` is the name of the VRF which is preconfigured in context configuration mode.

Static Route Configuration

This section provides the optional configuration example for configuring static routes when the route to the server is not learnt from the corporate over OSPFv2:

```

configure
context <vpn_context_name>
  ip route <internal_ip_address/mask> tunnel <tunnel_intf_name> vrf <vrf_name>
end

```

Notes:

- <vpn_context_name> is the name of the system context you want to use for static route configuration.
- <internal_ip_address/mask> is the network IP address with sub-net mask to be used as static route.
- <tunnel_intf_name> is name of a predefined tunnel type IP interface which is to be used for GRE tunnel interface.
- <vrf_name> is the name of the VRF which is preconfigured in context configuration mode.

Verifying Your Configuration

This section explains how to display and review the configurations after saving them in a .cfg file as described in the *System Administration Guide* and also to retrieve errors and warnings within an active configuration for a service.



Important All commands listed here are under Exec mode. Not all commands are available on all platforms.

These instructions are used to verify the GRE interface configuration.

Step 1 Verify that your interfaces are configured properly by entering the following command in Exec Mode:

```
show ip interface
```

The output of this command displays the configuration of the all interfaces configured in a context.

```

Intf Name:      foo1
Intf Type:      Broadcast
Description:
IP State:       UP (Bound to 17/2 untagged, ifIndex 285343745)
IP Address:     209.165.200.225      Subnet Mask:      255.255.255.0
Bcast Address:  209.165.200.254        MTU:              1500
Resoln Type:    ARP                  ARP timeout:      60 secs
L3 monitor LC-port switchover: Disabled
Number of Secondary Addresses: 0
Intf Name:      foo2
Intf Type:      Tunnel (GRE)
Description:
VRF:           vrf-tun
IP State:       UP (Bound to local address 209.165.200.225 (foo1), remote address
209.165.200.229)
IP Address:     209.165.200.228      Subnet Mask:      255.255.255.224
Intf Name:      foo3
Intf Type:      Tunnel (GRE)
Description:
IP State:       DOWN (<state explaining the reason of being down>)
IP Address:     209.165.200.232      Subnet Mask:      255.255.255.224

```

Step 2 Verify that GRE keep alive is configured properly by entering the following command in Exec Mode:

```
show ip interface gre-keepalive
```

The output of this command displays the configuration of the keepalive for GRE interface configured in a context.



CHAPTER 21

GTP-based S2b Interface Support on the P-GW and SAEGW

This chapter describes the GTP-based S2b interface support feature on the standalone P-GW and the SAEGW.

- [Feature Description, on page 439](#)
- [How the S2b Architecture Works, on page 441](#)
- [How the S2a Architecture Works, on page 463](#)
- [Configuring the GTP-based S2b Interface on the P-GW and SAEGW, on page 477](#)
- [Monitoring the GTP-based S2b Interface Feature, on page 478](#)
- [Monitoring the GTP-based S2a Interface Feature, on page 480](#)

Feature Description

This section describes the GTP-based S2a/S2b interface implementation on the P-GW and SAEGW.

GTP-based S2b Interface Support on the Standalone P-GW and SAEGW



Important GTP-based S2b interface support is a license-controlled feature. Contact your Cisco account or support representative for licensing information.

The S2b interface reference point connects the standalone P-GW with the ePDG and the P-GW of the SAEGW with the ePDG. Communication runs between the non-trusted non-3GPP ePDG (Evolved Packet Data Gateway) and the P-GW uses PMIPv6 (Proxy Mobile IP version 6) for providing access to the EPC. GTPv2-C is the signaling protocol used on the S2b. The S2b interface is based on 3GPP TS 29.274.

The S2b interface uses the PMIPv6 protocol to establish WLAN UE sessions with the P-GW. It also supports the transport of P-CSCF attributes and DNS attributes in PBU (Proxy-MIP Binding Update) and PBA (Proxy-MIP Binding Acknowledgment) messages as part of the P-CSCF discovery performed by the WLAN UEs. When the P-CSCF Address information is missing, P-CSCF Discovery is initiated upon an S4-SGSN-to-LTE (and vice versa) handoff. If the P-CSCF Address information is already available, there is no need to explicitly trigger another P-CSCF Discovery upon S4-SGSN to LTE (and vice versa) handoff.

Example: The UE tries to simultaneously connect to different APNs through different access networks only if the home network supports such simultaneous connectivity. The UE determines that the network supports

such simultaneous connectivity over multiple accesses if the UE is provisioned with or has received per-APN inter-system routing policies. So the UE can have independent PDN connections via multiple access types.

The access types supported are 4G and WiFi.

The S2b interface implementation on the P-GW and SAEGW supports the following functionality:

- UE connecting to PDN via WiFi access
- UE multiple PDN connections
- Initial Attach
- LTE to WiFi Handoff
- WiFi to LTE Handoff

GTP-based S2a Interface Support on the Standalone P-GW and SAEGW



Important GTP-Based S2a Interface Support is a licensed-controlled feature. Contact your Cisco account or support representative for detailed licensing information.

GTP-based S2a interface support is available on the P-GW and SAEGW. Operators deployed with the SAEGW are now able to integrate Trusted WiFi network functionality using this feature.

The S2a interface connects the standalone P-GW and P-GW of the SAEGW with the HSGW of the eHRPD. Specifically, the S2a interface supports the bearer interface by providing signaling and mobility support between a trusted non-3GPP access point (HSGW) and the standalone P-GW or P-GW of the SAEGW. It is based on Proxy Mobile IP but also supports Client Mobile IPv4 FA mode which allows connectivity to trusted non-3GPP IP access points that do not support PMIP.

When the WLAN is considered as trusted by the operator, the Trusted WLAN Access Network (TWAN) is interfaced with the EPC as a trusted non-3GPP access via the S2a interface to the P-GW. Support has been extended for WiFi-to-LTE handovers using Make and Break for the SAEGW service. Multi-PDN handovers are also supported as part of this feature.

Supported functionality includes:

- Initial Attach
- WiFi-to-LTE handover
- LTE-to-WiFi handover
- Multi-PDN handovers

Supported protocols include:

- Transport Layer: UDP, TCP
- Tunneling: GRE IPv6
- Network Layer: IPv4, IPv6
- Data Link Layer: ARP
- Physical Layer: Ethernet

Relationships to Other Features

This section describes how the GTP-based S2b and S2a interface support feature is related to other features.

- A P-GW service must be configured and operational before GTP-based s2b interface support can be configured on the standalone P-GW and SAEGW.
- GTP-based S2b interface support must also be configured and operational on the ePDG to support this feature.
- A P-GW service must be configured and operational before GTP-based S2a interface support can be configured on the standalone P-GW and SAEGW.

How the S2b Architecture Works

Standalone P-GW Architecture for S2b Interface Support

The GTP-based S2b interface architecture is part of the P-GW deployment in the E-UTRAN/EPC Network. The P-GW communicates with the ePDG over the S2b interface, and the ePDG connects to the WLAN offload architecture via an IPsec interface.

Figure 79: Standalone P-GW: GTP-based S2b Interface Implementation in the E-UTRAN/EPC Network

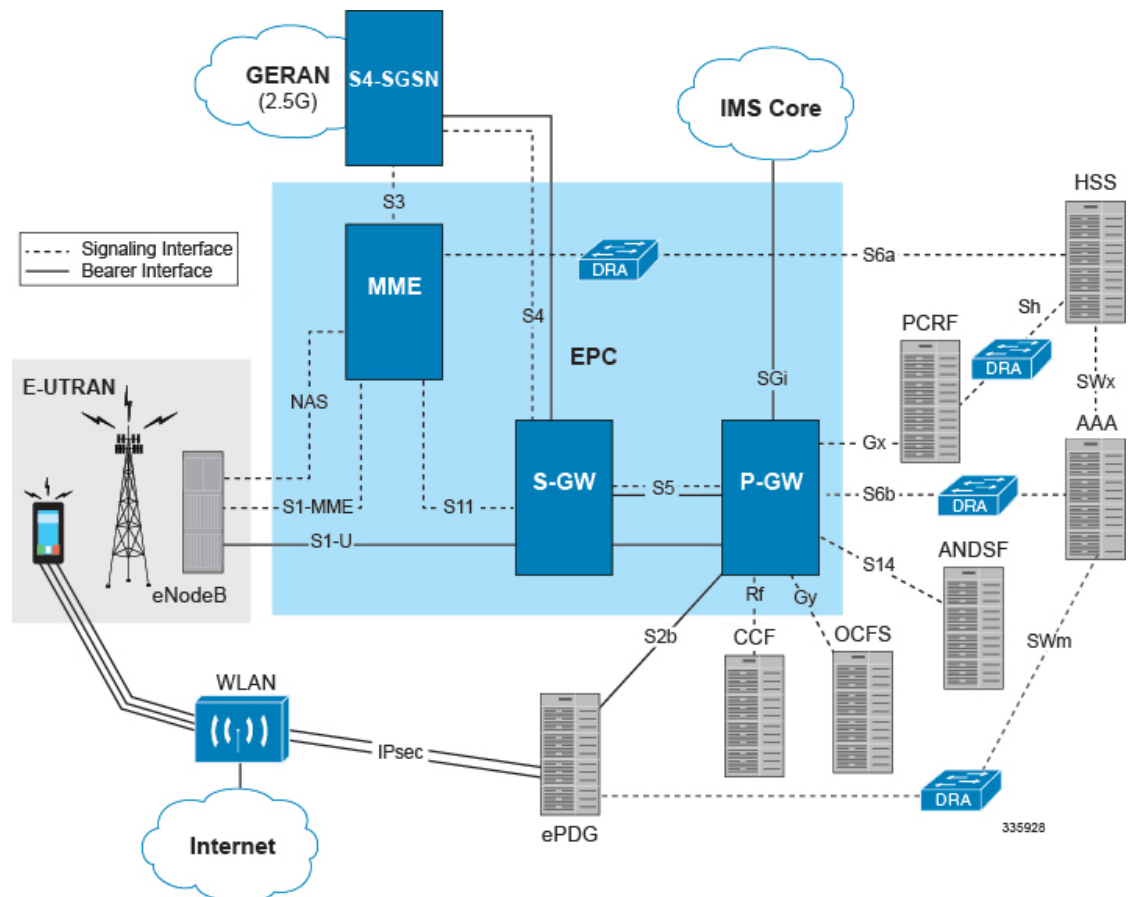

SAEGW Architecture for S2b Interface Support

The GTP-based S2b interface architecture is part of the SAEGW deployment in the E-UTRAN/EPC Network. The P-GW of the SAEGW communicates with the ePDG over the S2b interface, and the ePDG connects to the WLAN offload architecture via an IPsec interface.

Figure 80: SAEGW: GTP-based S2b Interface Implementation in the E-UTRAN/EPC Network

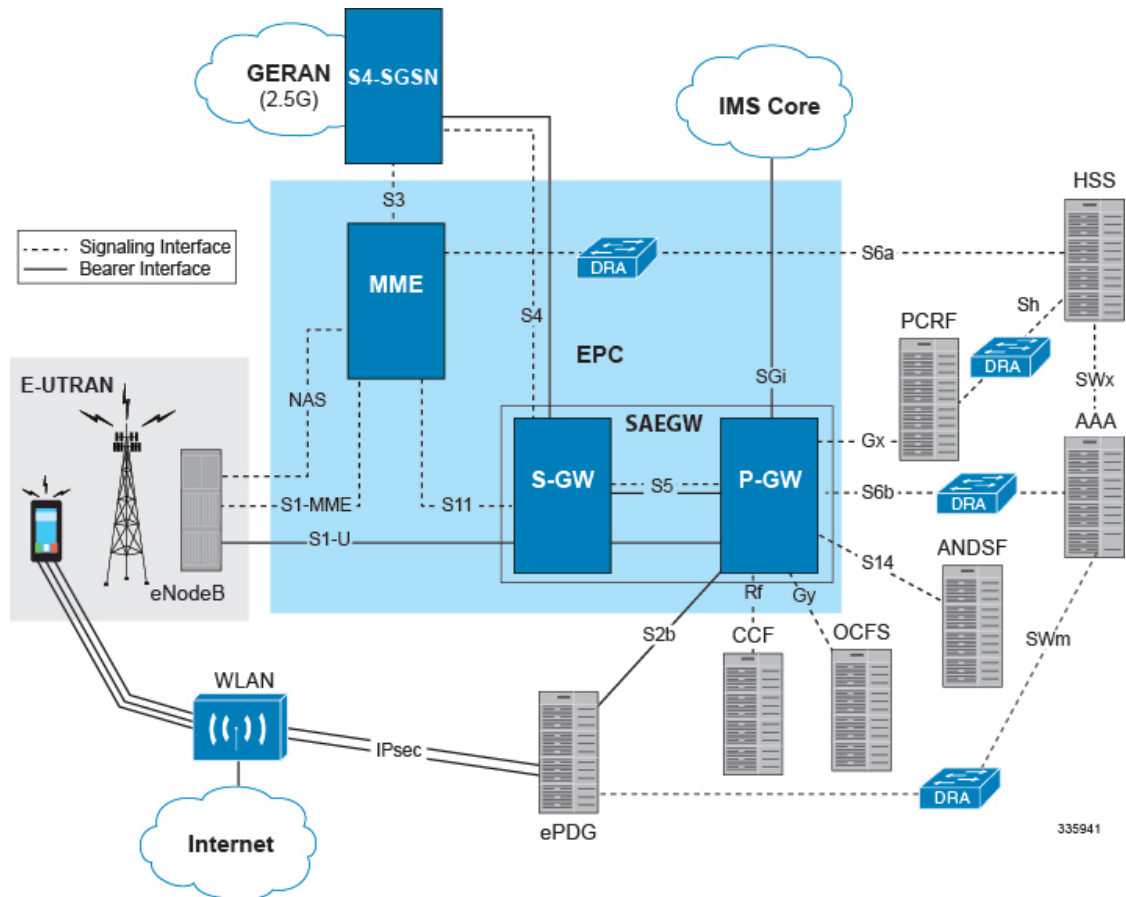

Limitations on S2b Interface Support for the P-GW and SAEGW

Note the following limitations of the GTP-based S2b interface implementation on the P-GW and SAEGW:

- Only the following interfaces/access types from the WiFi Offload and VLC Flows are supported:
- Access Types:
 - WiFi
 - LTE
- Interfaces:
 - S6b
 - Gy
 - Rf

- Gx
- GTPv2 (S2b)
- Legacy Lawful Intercept is supported on the S2b interface on the standalone P-GW, but is not qualified on the S2b interface on the SAEGW at this time.

Standalone P-GW Call Flows

This section provides call flows that illustrate the basic functionality of the GTP-based S2b interface support on the standalone P-GW.

Figure 81: Initial Attach Call Flow - P-GW

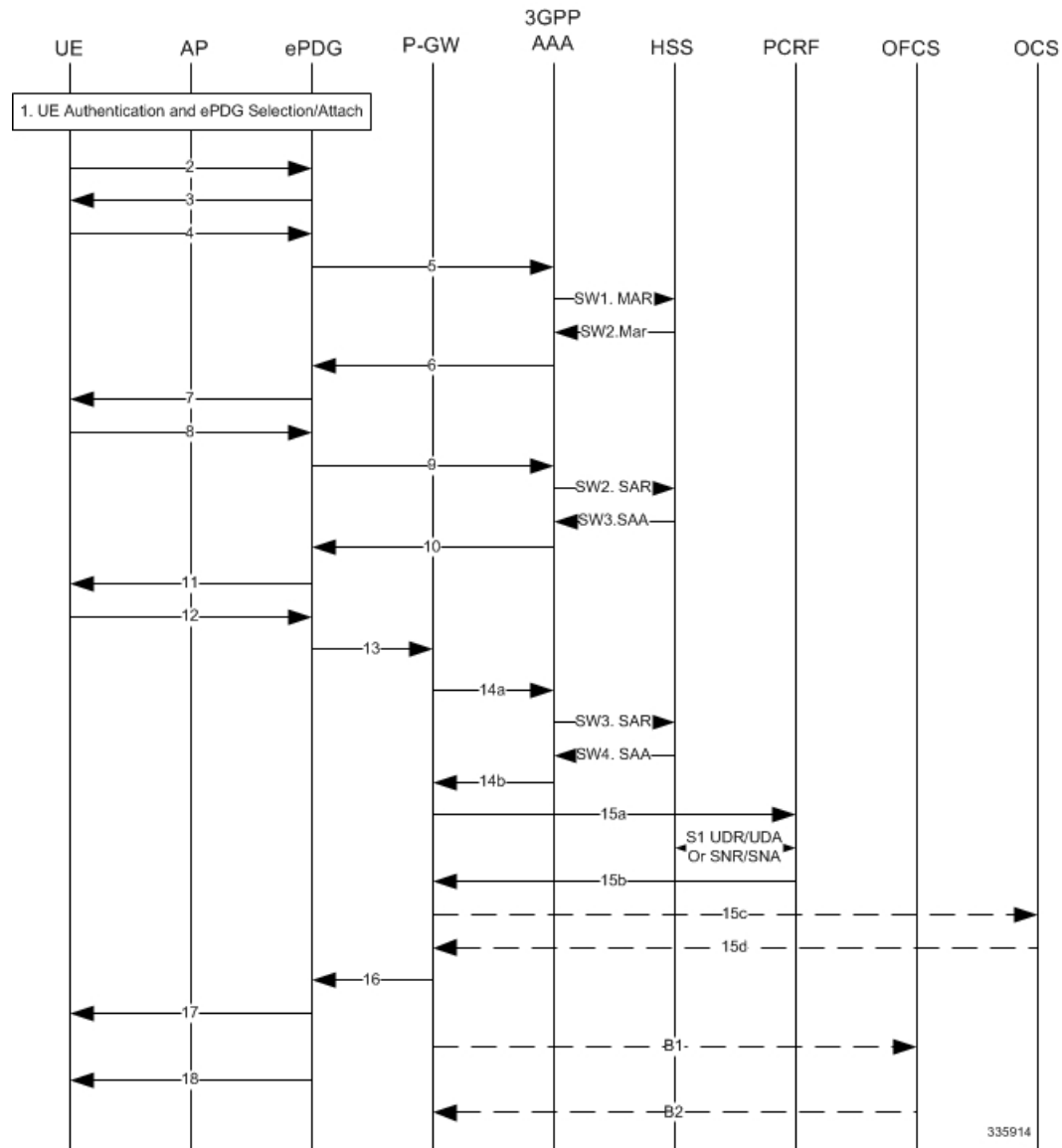
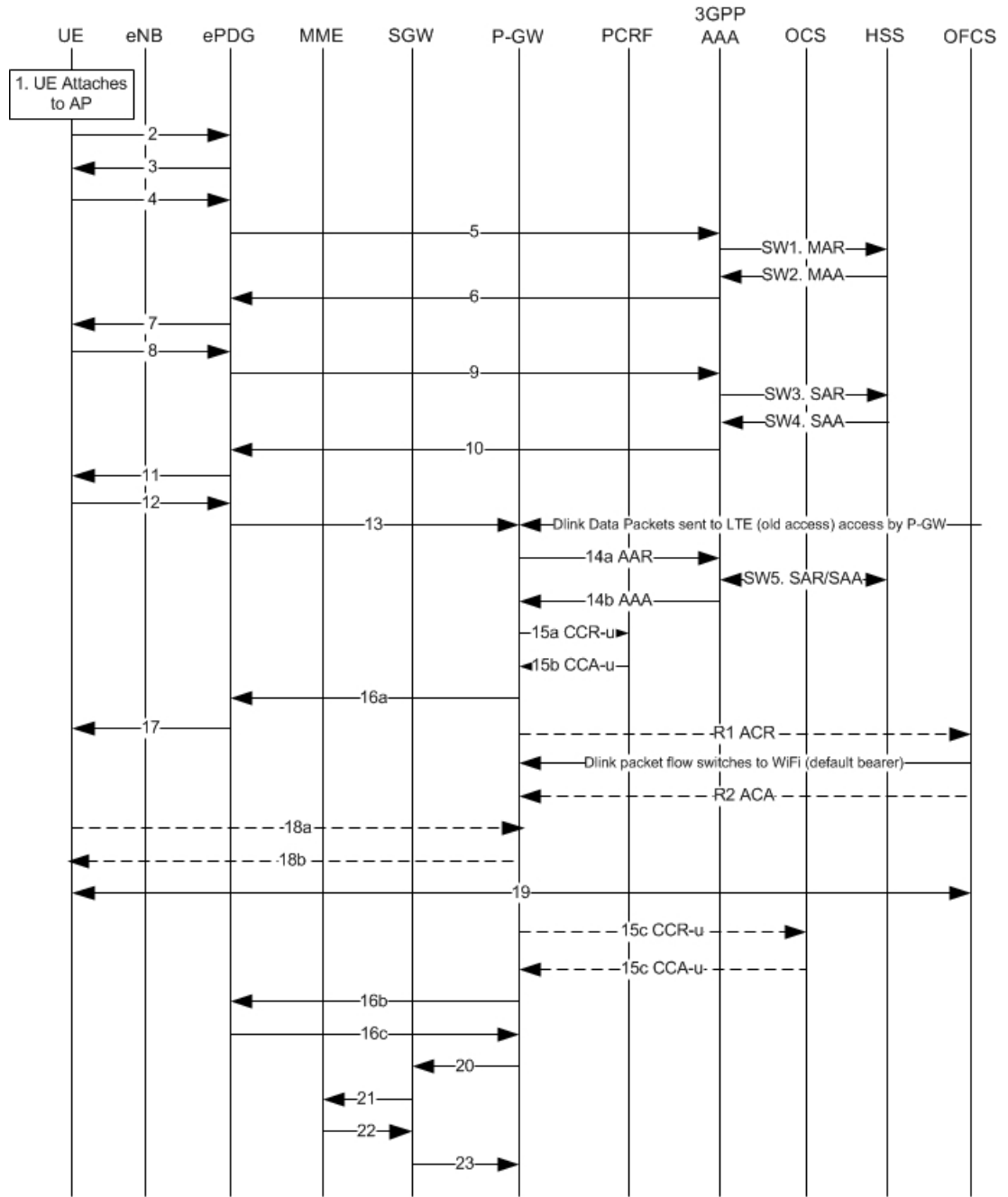

Table 41: Initial Attach - P-GW

Step	Description
1	UE performs initial Access Point association and authentication if necessary.
2 - 11	The UE creates a connection with the ePDG.
12	UE sends IKE_AUTH request (AUTH). The UE takes its own copy of the MSK as input to generate the AUTH parameter to authenticate the first IKE_SA_INIT message.
13	ePDG selects the P-GW based on Node Selection options. The ePDG sends Create Session Request.
14a	The P-GW sends AAR to the 3GPP AAA to authorize the PDN for the subscriber and to update P-GW address on the HSS for the APN.
SW3	The 3GPP AAA updates the HSS with the P-GW address for the APN and retrieves Subscriber-APN profiles from the HSS.
SW4	The HSS sends Server-Assignment-Answer (Session-Id, Result-Code, Experimental-Result (Vendor-Id, Experimental-Result-Code))
14b	The 3GPP AAA sends AAA.
15a	The P-GW sends an indication of IP-CAN establishment to the PCRF with CCR to indicate establishment of a new IP CAN session.
S1	The PCRF downloads (and caches) user profile (by sending an Sh: UDR (User-Identity, Service-Indication, Data-Reference) and receiving an Sh: UDA (Result-Code, User-Data)).
S2	The PCRF may subscribe to profile update notification.
15b	The PCRF Acknowledges IP CAN Session Establishment with a CCA message.
15c	If the Online AVP is set in the CCA from the PCRF (UC users / CF / RTR), the P-GW shall conditionally send a CCR-Initial.
15d	The OCS responds with a CCA to the P-GW.
16	The P-GW allocates the requested IP address session and responds back to the ePDG with a Create Session Response message.
17	The ePDG sends the assigned IP address in the configuration payload (CFG_REPLY). The AUTH parameter is sent to the UE together with the configuration payload, security associations and the rest of the IKEv2 parameters and the IKEv2 negotiation terminates.
18	ePDG sends Router Advertisement to ensure IP Stack is fully initialized. P-GW disables the Router Advertisement to the UE.
B1	If the Offline AVP is set in the CCA from the PCRF, then after IP-CAN session establishment procedure is complete, the P-GW shall send a ACR-Start to the OFCS.
B2	The OFCS responds with an ACA to the P-GW.

Figure 82: P-GW: LTE to WiFi Handoff Call Flow



335938

Table 42: P-GW LTE to WiFi Handoff

Step	Description
1	Authentication and ePDG Selection. UE performs initial Access Point association and authentication if necessary.

Step	Description
2	UE to ePDG: IKEv2 SA_INIT. The UE sends IKE_SA_INIT Request.
3	ePDG to UE: INIT Response. The ePDG responds with an IKE_SA_INIT Response. The ePDG will start the IKEv2 setup timer when sending the IKE_SA_INIT Response.
4	UE sends Auth_Request.
5	ePDG to AAA: DER. The ePDG sends the DER message to the 3GPP AAA Server. Note the NAI shall not contain the AP MAC address sent in the username that comes in the IKE message
SW1. MAR	AAA to HSS: MAR. The 3GPP AAA Server fetches the user profile and authentication vectors from HSS over SWx. The 3GPP AAA server look up the IMSI of the authenticated user based on the received user identity and includes the EAP-AKA as requested authentication method in the request sent to the HSS. The AAA sends the Multimedia-Auth-Request MAR, Origin-Host, Origin-Realm, Destination-Realm, Destination-Host, User-Name, RAT-Type, SIP-Auth-Data-Item, SIP-Number-Auth-Items, and Routing-Information).
SW2. MAA	HSS to AAA: MAA. The HSS shall then generate authentication vectors with AMF separation bit = 0 and send them back to the 3GPP AAA server. The HSS sends the Multimedia-Auth-Answer MAA.
6	AAA to ePDG: DEA. The 3GPP AAA Server initiates the authentication challenge and responds with DEA.
7	ePDG to UE: IKE_AUTH. The ePDG responds with IKE_AUTH. The identity is the IP address of the ePDG; the AUTH payload authenticates the first IKE_SA_INIT response. If the UE requested certificates, the CERT is included. The EAP message received from the 3GPP AAA Server is included in order to start the EAP procedure over IKEv2.
8	UE to ePDG: IKE_AUTH Request. The UE checks the authentication parameters and responds to the authentication challenge. The only payload (apart from the header) in the IKEv2 message is the EAP message IKE_AUTH Request (EAP).
9	ePDG to AAA: DER. The ePDG sends DER (Base AVPs, Auth Request Type, EAP Payload, Auth-Session-State, Service Selection) to the 3GPP AAA Server.
SW3. SAR	AAA to HSS: SAR. The 3GPP AAA updates the HSS with the 3GPP AAA Server Address information for the authenticated user. The AAA sends Server-Assignment-Request, Origin-Host, Origin-Realm, Destination-Host, Destination-Realm, User-Name (IMSI-NAI), Server-Assignment-Type (REGISTRATION)).
SW4 SAA	HSS to AAA: SAA. The HSS sends Server-Assignment-Answer.
10	AAA to ePDG: DEA. The 3GPP AAA Server sends an EAP success. The 3GPP AAA Server checks in user's subscription if he/she is authorized for non-3GPP access before responding with DEA.
11	ePDG to UE: IKE_AUTH_Response. ePDG sends IKE_AUTH_Response (EAP).

Step	Description
12	UE to ePDG: IKE_AUTH_Request. UE sends IKE_AUTH request (AUTH) The UE takes its own copy of the MSK as input to generate the AUTH parameter to authenticate the first IKE_SA_INIT message.
13	ePDG to P-GW: Create Session Request. The ePDG sends Create Session Request to the P-GW. P-CSCF is requested if the UE requested P-CSCF in the IKE Config request.
14a	P-GW to 3GPP-AAA: AAR. The P-GW sends AAR to the 3GPP AAA to authorize the APN for the subscriber and to update P-GW address on the HSS for the APN.
SW5. SAR/SAA	AAA to HSS: SAR. The 3GPP AAA updates the HSS with the P-GW address for the APN. The AAA sends Server-Assignment-Request.
14b AAA	3GPP AAA to P-GW: AAA. 3GPP AAA sends AAA to the P-GW.
15a CCR-u	P-GW to PCRF: CCR-U. The P-GW sends an indication of IP-CAN modification to the PCRF with CCR to indicate modification of the IP-CAN session.
15b CCA-u	PCRF to P-GW: CCA. The PCRF Acknowledges of IP-CAN Session Modification with a CCA message. This message includes the Policy and Charging rules the P-GW will enforce and triggers for events that must be reported by the P-GW.
16a	P-GW to ePDG: Create Session Response. The P-GW identifies the S5 session and re-allocates the requested IP address session and responds back to the ePDG with a Create Session Response message. The P-CSCF private IE is included if the ePDG had included the P-CSCF request in message 13.
17	ePDG to UE: IKE_AUTH. The ePDG sends IKE_AUTH.
R1 ACR	P-GW to OFCS: ACR. The P-GW sends an ACR-Interim to the OFCS.
R2 ACA	OFCS to P-GW: ACA. The OFCS responds with an ACA to the P-GW.
18a	UE sends a Router Solicitation message.
18b	The P-GW sends a Router Advertisement and include the globally unique /64 IPv6 prefix previously assigned.
19	The UE sends a SIP Re-Register once it successfully identifies it has changed access network to indicate the RAT change to the P-CSCF and assigned IP address is unchanged. UE will include 802.11 a/b/g/n in the PANI header. The SIP re-registration does not impact the way the P-CSCF does charging as charging is not used from the P-CSCF in IMS case.
15c CCR-u	P-GW to OCS: CCR-U. If the Online AVP is set in the CCA from the PCRF, the P-GW shall conditionally send a CCR-Update to the OCS to request online charging quota for the PDN session.
15d CCA-u	OCS to P-GW: CCA. The OCS responds with a CCA to the P-GW.
16b	P-GW to ePDG: Create Bearer Request. The IMS PDN has one or more dedicated bearers established prior to handoff and the P-GW also sends Create Bearer Request to the ePDG. Note that Charging ID is not sent on S2b.

Step	Description
16c	ePDG to P-GW: Create Bearer Response. The ePDG sends Create Bearer Response message
20	P-GW to S-GW: Delete Bearer Request. The P-GW sends the Delete Bearer Request (Linked EPS Bearer ID (if last bearer) or EPS Bearer ID, Cause (RAT changed from 3GPP to Non-3GPP)) to the S-GW. This message may be sent any time after message 13, the create session request.
21	S-GW to MME: Delete Bearer Request. The S-GW sends the Delete Bearer Request (Linked EPS Bearer ID (if last bearer) or EPS Bearer ID, Cause (RAT changed from 3GPP to Non-3GPP)) to the MME. The MME releases the E-UTRAN bearers if not already released. The MME does not send Notify Request to HSS at this point, as the cause IE is RAT change to Non-3GPP. MME does not page the UE either or initiate any NAS signaling and remove the locally stored PDN state and does S1 context release to the eNodeB if it has not already been triggered by the eNodeB. For last PDN MME removes all locally stored UE state.
22	MME to S-GW: Delete Bearer Response. The MME sends Delete Bearer Response to the S-GW.
23	S-GW to P-GW: Delete Bearer Response. The S-GW sends Delete Bearer Response to the P-GW.

Figure 83: P-GW: WiFi to LTE Handoff

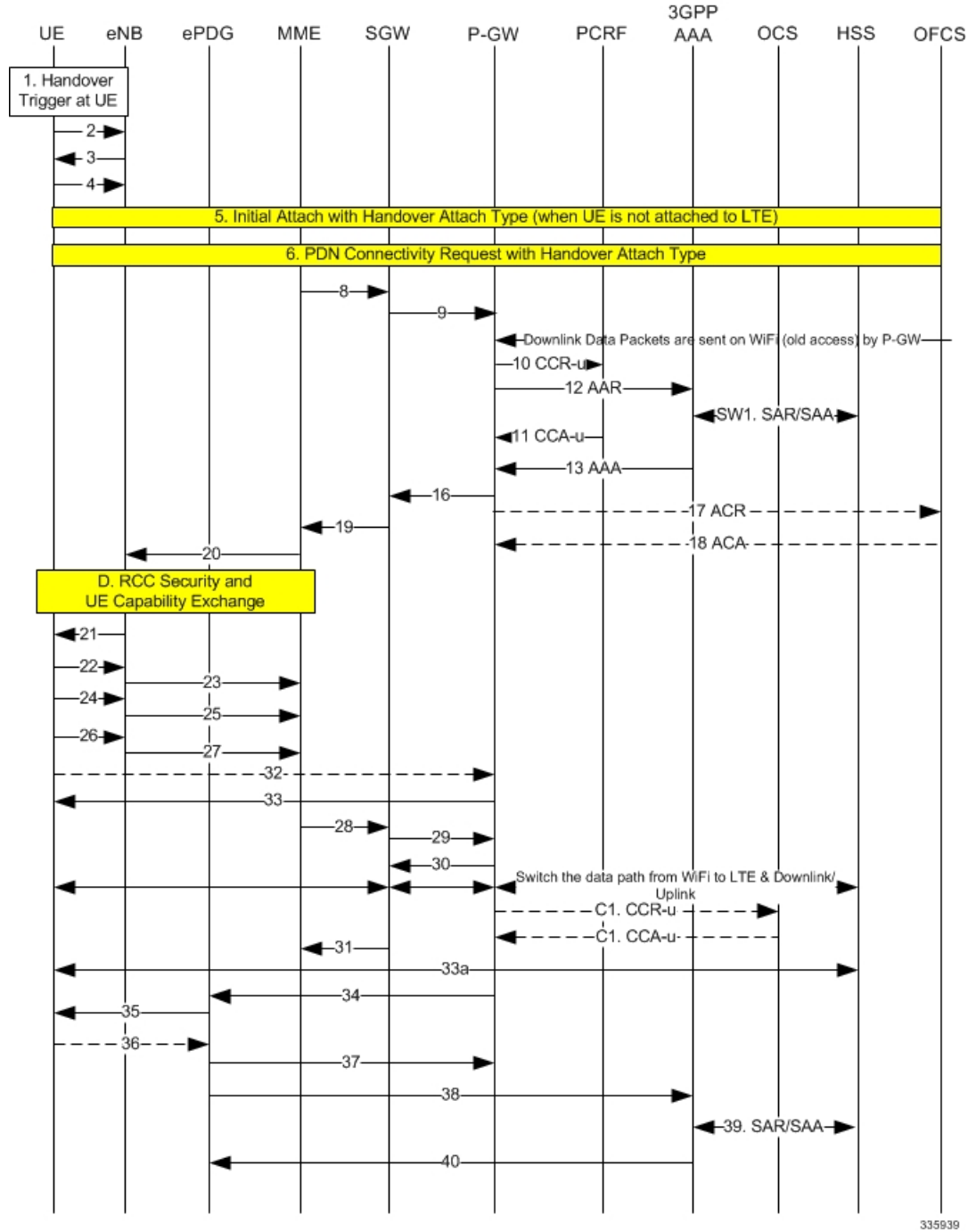

Table 43: P-GW WiFi to LTE Handoff Procedure

Step	Description
1	A handover trigger occurs at the UE.

Step	Description
2, 3	RRC Connection Request/Connection Setup. The UE and eNodeB exchange signaling to set up an RRC connection (5.3.3, TS 36.331).
4	RRC Connection Setup Complete [Attach Request]. The UE sends RRC Connection Setup Complete message to the eNodeB.
5	Attach Request from eNB to MME. The UE indicates in the Attach Request to LTE that this is a Handover Attach. The eNodeB selects the MME. The eNodeB forwards the Attach Request message in an Initial UE Message to the MME.
6	MME selects the same P-GW based on HSS provided PGW FQDN and sends the Create Session request.
8	The MME selects the PGW/SGW. The MME sends a Create Session Request to the SGW with RAT as EUTRAN and the handoff indicator set to TRUE.
9	The SGW sends a Create Session Request to the PDN GW in order to establish the handoff (handoffindicator is set to true). RAT type is E-UTRAN.
10	P-GW to PCRF CCR IP-CAN Session Modification Procedure. The PCEF sends a CC-Request (CCR) Command with CC-Request-Type set to UPDATE_REQUEST. The APN-AMBR is included in the QoS-information AVP.
12	The P-GW sends AAR to 3GPP-AAA and includes the RAT type of the new connection.
SW1. SAR/SAA	The 3GPP-AAA sends SAR to HSS to retrieve the user profile, the HSS returns an SAA. The P-GW-FQDN is not updated as the 3GPP-AAA is not registered for this user.
11	PCRF ' P-GW: CCA IP-CAN Session modification Procedure. On receiving the CCR the PCRF shall send a CC-Answer (CCA) Command to install the PCC rules and event triggers for all configured and established bearers. The QoS-Information AVP contains APN-AMBR-UL and APN-AMBR-DL.
13	The 3GPP-AAA responds with AAA.
16	P-GW to S-GW: Create Session Response + Create Bearer Request. The P-GW responds with a Create Session Response message to the S-GW. The P-GW provides IPv6 Prefix. Subject to operator configuration the P-GW can begin to forward downlink data and the S-GW shall buffer any downlink data packets.
17	P-GW to OFCS: ACR. After the P-GW sends the PBA, the P-GW shall send an ACR-Interim to the OFCS.
18	OFCS to P-GW: ACA. The OFCS responds with an ACA to the P-GW.
19	Create Session Response. The S-GW sends Create Session Response to the MME.
20	Initial Context Setup Request/Attach Accept. The Attach Accept is sent as NAS PDU in the Initial Context Setup Request from MME to eNodeB. Attach Accept message contains new GUTI.

Step	Description
D	These procedures occur independently of the location procedures. These procedures only apply to initial attach scenarios.
21	RRC Connection Re-configuration. The eNodeB sends the RRC Connection Reconfiguration message including the EPS Radio Bearer Identity to the UE, and the Attach Accept message to the UE. The APN is provided to the UE to notify it of the APN for which the activated default bearer is associated.
22	RRC Connection Re-configuration Complete. The UE sends the RRC Connection Reconfiguration Complete message to the eNodeB.
23	Initial Context Setup Response. The eNodeB sends Initial Context Setup Response to the MME.
24	Uplink Information Transfer. The UE sends an Uplink Information Transfer message.
25	Attach Complete. The eNodeB forwards the received Attach Complete message in an Uplink NAS Transport as part of NAS PDU.
26	Uplink Information Transfer. When the UE has received Activate dedicated EPS Bearer Context Request message in the Attach Accept message, the UE sends Activate Dedicated EPS Bearer Context Accept message in a Uplink Information Transfer message.
27	UL NAS Transport. The eNB passes the Activate Dedicated EPS Bearer Context Accept message received in Step 14.b, to the MME in a UL NAS Transport message. At this time, the uplink data can be sent on the dedicated bearer.
32	Router Solicitation. This step may happen any time after step 26. For IPv6 PDN, the UE may send a Router Solicitation to the P-GW.
33	Router Advertisement. This step may happen any time after step 29 if the UE requested IPv4v6 or IPv6 PDN type. On receipt of the RS or prior the P-GW shall send a Router Advertisement and include the globally unique /64 IPv6 prefix previously assigned.
28	Modify Bearer Request / Create Bearer Response. On receiving both Initial Context Setup Response and Attach Complete, the MME sends a Modify Bearer Request message to the S-GW. The MME piggybacks the Modify Bearer Request message on the Create Bearer Response message.
29	The S-GW processes each message independently. The S-GW forwards the Create Bearer Response to the P-GW. At this time, the P-GW can send downlink data on the dedicated bearer for the IMS traffic. Since Handover Indication is set to TRUE in the Modify Bearer Request, the S-GW sends Modify Bearer Request to the P-GW separately. Based on TS 23.401, the P-GW switches the downlink traffic to S5 upon receiving this message. However, subject to operator configuration, this switching occurs at Create Session Request above (C3).
30	The P-GW sends Modify Bearer Response (Cause) message to the S-GW.

Step	Description
C1. CCR-u	P-GW to OCS: CCR-U. If the Online AVP is set in the CCA from the PCRF, the P-GW shall conditionally send a CCR-Update to the OCS to request online charging quota for the PDN session.
C1. CCA-u	OCS to P-GW: CCA. The OCS responds with a CCA to the P-GW.
31	The S-GW sends Modify Bearer Response to the MME. The S1 S-GW F-TEID is the same as the S1-U S-GW F-TEID sent in Create Session Response from the S-GW to the MME. The S-GW can now start sending downlink packets to eNB and the switching of the data path from WiFi to LTE occurs after the Modify Bearer Response.
33a	SIP Re-registration RAT Change. The UE sends a SIP Re-Register to the P-CSCF to indicate that it detected a RAT change and assigned IP address remained unchanged.
34	P-GW to ePDG: Delete Bearer Request. The P-GW sends Delete Bearer Request to ePDG to disconnect the session.
35	ePDG to UE: IKEv2 Informational Delete Request. The ePDG sends IKEv2 Informational Delete Request () to UE to disconnect the session.
34	UE to ePDG: IKEv2 Informational Delete Response. UE responds with IKEv2 Informational Delete Response () and initiates air interface resource release. This step is conditional and UE may not send this response.
37	ePDG to P-GW: Delete Bearer Response. The ePDG sends Delete Bearer Response to the P-GW.
38	ePDG to AAA: Session Termination Request. The ePDG sends STR to the 3GPP AAA.
39	AAA to HSS: Server Assignment Request. The AAA sends Server-Assignment-Request to de-register. HSS to AAA: SAA. The HSS sends Server-Assignment-Answer.
40	AAA to ePDG: Session Termination Answer. The AAA sends STA to the ePDG.

SAEGW GTP-based S2b Call Flows

This section provides call flows that illustrate the basic functionality of the GTP-based S2b interface support on the SAEGW.

Figure 84: Initial Attach Call Flow - SAEGW

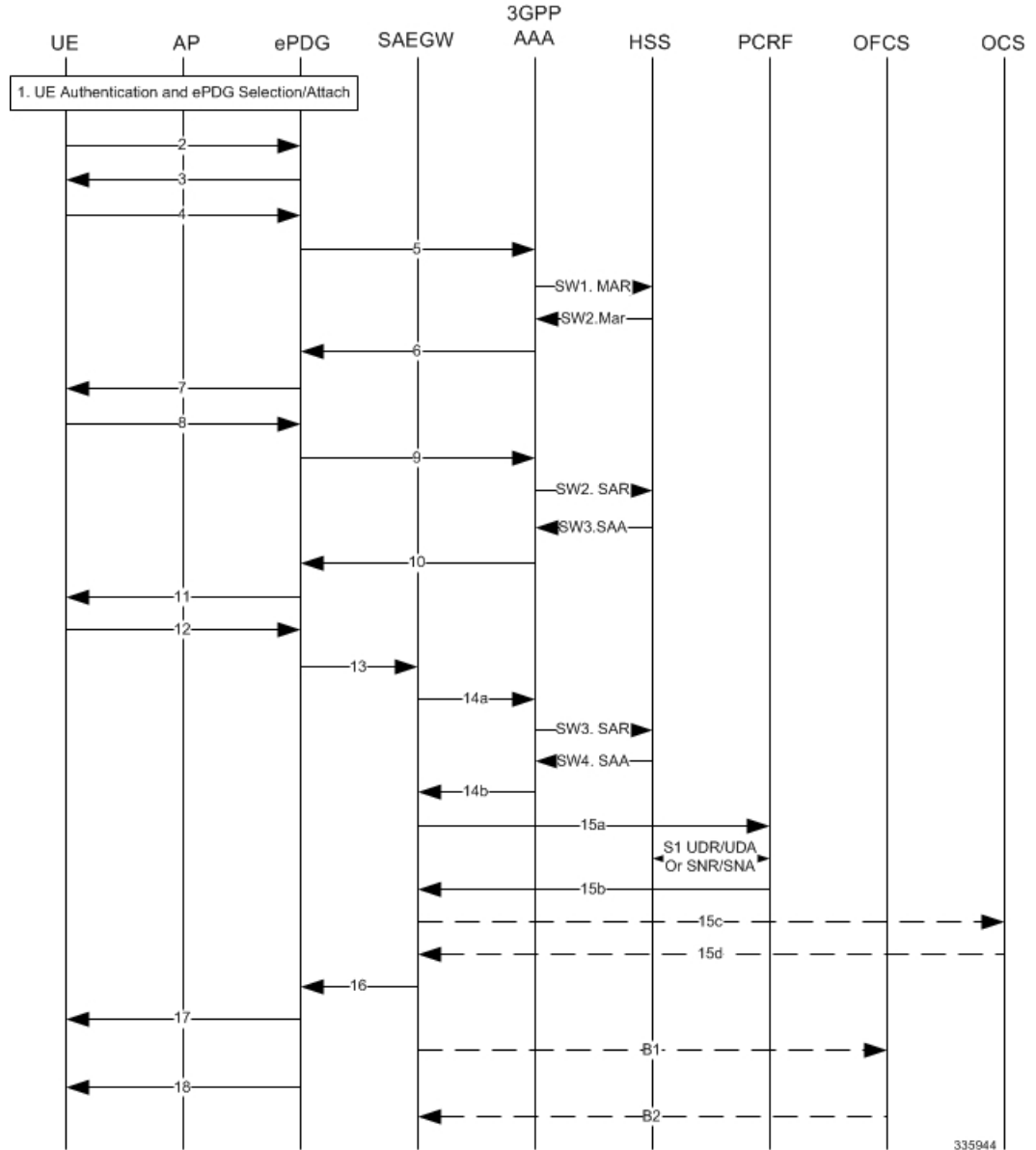
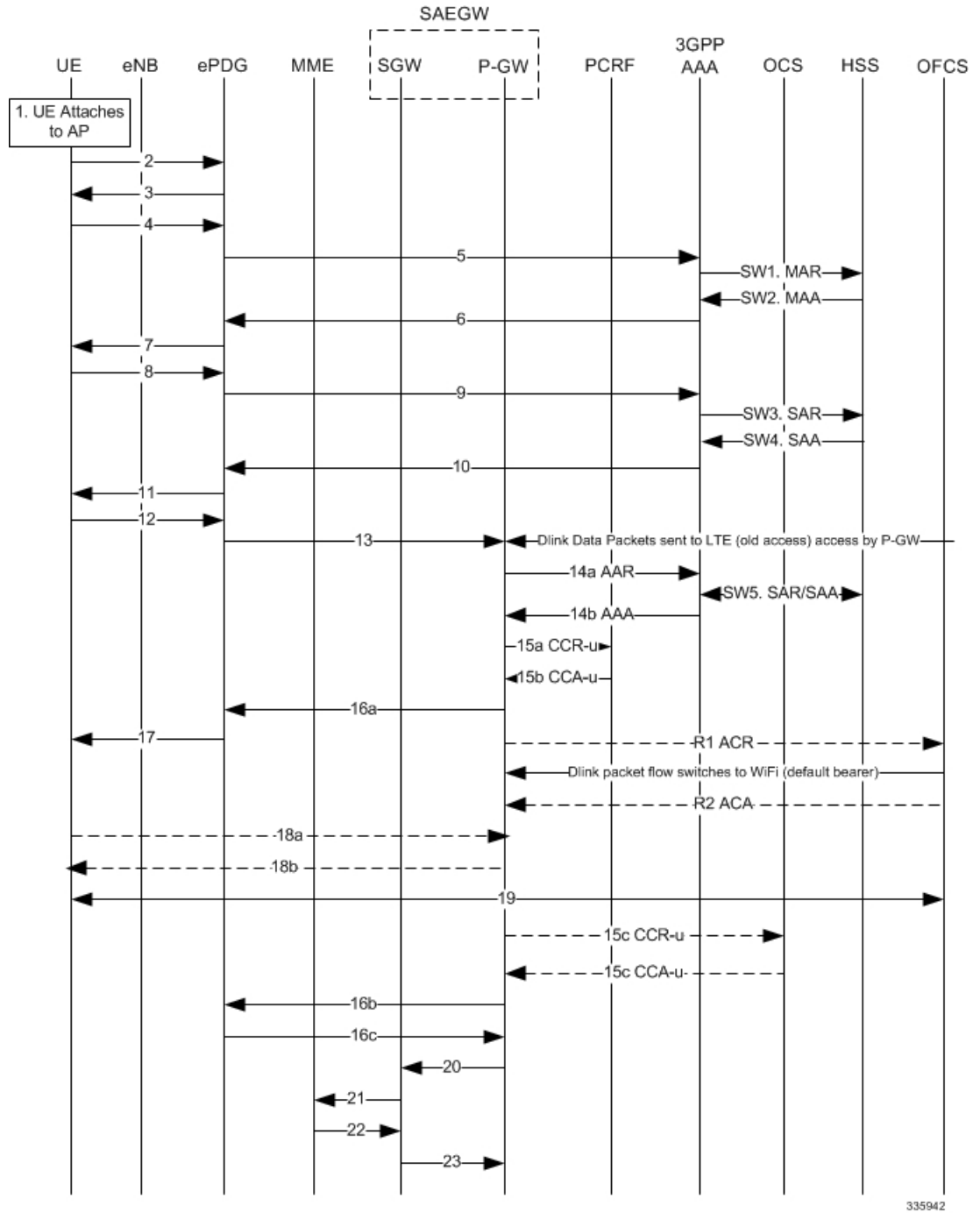

Table 44: Initial Attach - SAEGW

Step	Description
1	UE performs initial Access Point association and authentication if necessary.
2 - 11	The UE creates a connection with the ePDG.
12	UE sends IKE_AUTH request (AUTH). The UE takes its own copy of the MSK as input to generate the AUTH parameter to authenticate the first IKE_SA_INIT message.

Step	Description
13	ePDG selects the P-GW of the SAEGW based on Node Selection options. The ePDG sends Create Session Request.
14a	The P-GW of the SAEGW sends AAR to the 3GPP AAA to authorize the PDN for the subscriber and to update P-GW address on the HSS for the APN.
SW3	The 3GPP AAA updates the HSS with the P-GW address of the SAEGW for the APN and retrieves Subscriber-APN profiles from the HSS.
SW4	The HSS sends Server-Assignment-Answer (Session-Id, Result-Code, Experimental-Result (Vendor-Id, Experimental-Result-Code))
14b	The 3GPP AAA sends AAA.
15a	The P-GW of the SAEGW sends an indication of IP-CAN establishment to the PCRF with CCR to indicate establishment of a new IP CAN session.
S1	The PCRF downloads (and caches) user profile (by sending an Sh: UDR (User-Identity, Service-Indication, Data-Reference) and receiving an Sh: UDA (Result-Code, User-Data)).
S2	The PCRF may subscribe to profile update notification.
15b	The PCRF Acknowledges IP CAN Session Establishment with a CCA message.
15c	If the Online AVP is set in the CCA from the PCRF (UC users / CF / RTR), the P-GW shall conditionally send a CCR-Initial.
15d	The OCS responds with a CCA to the P-GW.
16	The P-GW of the SAEGW allocates the requested IP address session and responds back to the ePDG with a Create Session Response message.
17	The ePDG sends the assigned IP address in the configuration payload (CFG_REPLY). The AUTH parameter is sent to the UE together with the configuration payload, security associations and the rest of the IKEv2 parameters and the IKEv2 negotiation terminates.
18	ePDG sends Router Advertisement to ensure IP Stack is fully initialized. The P-GW of the SAEGW disables the Router Advertisement to the UE.
B1	If the Offline AVP is set in the CCA from the PCRF, then after IP-CAN session establishment procedure is complete, the P-GW of the SAEGW shall send a ACR-Start to the OFCS.
B2	The OFCS responds with an ACA to the P-GW of the SAEGW.

Figure 85: SAEGW: LTE to WiFi Handoff Call Flow



335942

Table 45: SAEGW LTE to WiFi Handoff

Step	Description
1	Authentication and ePDG Selection. UE performs initial Access Point association and authentication if necessary.

Step	Description
2	UE to ePDG: IKEv2 SA_INIT. The UE sends IKE_SA_INIT Request.
3	ePDG to UE: INIT Response. The ePDG responds with an IKE_SA_INIT Response. The ePDG will start the IKEv2 setup timer when sending the IKE_SA_INIT Response.
4	UE sends Auth_Request.
5	ePDG to AAA: DER. The ePDG sends the DER message to the 3GPP AAA Server. Note the NAI shall not contain the AP MAC address sent in the username that comes in the IKE message
SW1. MAR	AAA to HSS: MAR. The 3GPP AAA Server fetches the user profile and authentication vectors from HSS over SWx. The 3GPP AAA server look up the IMSI of the authenticated user based on the received user identity and includes the EAP-AKA as requested authentication method in the request sent to the HSS. The AAA sends the Multimedia-Auth-Request MAR, Origin-Host, Origin-Realm, Destination-Realm, Destination-Host, User-Name, RAT-Type, SIP-Auth-Data-Item, SIP-Number-Auth-Items, and Routing-Information).
SW2. MAA	HSS to AAA: MAA. The HSS shall then generate authentication vectors with AMF separation bit = 0 and send them back to the 3GPP AAA server. The HSS sends the Multimedia-Auth-Answer MAA.
6	AAA to ePDG: DEA. The 3GPP AAA Server initiates the authentication challenge and responds with DEA.
7	ePDG to UE: IKE_AUTH. The ePDG responds with IKE_AUTH. The identity is the IP address of the ePDG; the AUTH payload authenticates the first IKE_SA_INIT response. If the UE requested certificates, the CERT is included. The EAP message received from the 3GPP AAA Server is included in order to start the EAP procedure over IKEv2.
8	UE to ePDG: IKE_AUTH Request. The UE checks the authentication parameters and responds to the authentication challenge. The only payload (apart from the header) in the IKEv2 message is the EAP message IKE_AUTH Request (EAP).
9	ePDG to AAA: DER. The ePDG sends DER (Base AVPs, Auth Request Type, EAP Payload, Auth-Session-State, Service Selection) to the 3GPP AAA Server.
SW3. SAR	AAA to HSS: SAR. The 3GPP AAA updates the HSS with the 3GPP AAA Server Address information for the authenticated user. The AAA sends Server-Assignment-Request, Origin-Host, Origin-Realm, Destination-Host, Destination-Realm, User-Name (IMSI-NAI), Server-Assignment-Type (REGISTRATION)).
SW4 SAA	HSS to AAA: SAA. The HSS sends Server-Assignment-Answer.
10	AAA to ePDG: DEA. The 3GPP AAA Server sends an EAP success. The 3GPP AAA Server checks in user's subscription if he/she is authorized for non-3GPP access before responding with DEA.
11	ePDG to UE: IKE_AUTH_Response. ePDG sends IKE_AUTH_Response (EAP).

Step	Description
12	UE to ePDG: IKE_AUTH_Request. UE sends IKE_AUTH request (AUTH) The UE takes its own copy of the MSK as input to generate the AUTH parameter to authenticate the first IKE_SA_INIT message.
13	ePDG to P-GW of SAEGW: Create Session Request. The ePDG sends Create Session Request to the P-GW of SAEGW. P-CSCF is requested if the UE requested P-CSCF in the IKE Config request.
14a	P-GW to 3GPP-AAA: AAR. The P-GW of SAEGW sends AAR to the 3GPP AAA to authorize the APN for the subscriber and to update P-GW address on the HSS for the APN.
SW5. SAR/SAA	AAA to HSS: SAR. The 3GPP AAA updates the HSS with the P-GW address for the APN. The AAA sends Server-Assignment-Request.
14b AAA	3GPP AAA to P-GW: AAA. 3GPP AAA sends AAA to the P-GW of SAEGW.
15a CCR-u	P-GW of SAEGW to PCRF: CCR-U. The P-GW sends an indication of IP-CAN modification to the PCRF with CCR to indicate modification of the IP-CAN session.
15b CCA-u	PCRF to P-GW of SA: CCA. The PCRF Acknowledges of IP-CAN Session Modification with a CCA message. This message includes the Policy and Charging rules the P-GW will enforce and triggers for events that must be reported by the P-GW.
16a	P-GW of SAEGW to ePDG: Create Session Response. The P-GW of SAEGW identifies the S5 session and re-allocates the requested IP address session and responds back to the ePDG with a Create Session Response message. The P-CSCF private IE is included if the ePDG had included the P-CSCF request in message 13.
17	ePDG to UE: IKE_AUTH. The ePDG sends IKE_AUTH.
R1 ACR	P-GW to OFCS: ACR. The P-GW sends an ACR-Interim to the OFCS.
R2 ACA	OFCS to P-GW: ACA. The OFCS responds with an ACA to the P-GW of SAEGW.
18a	UE sends a Router Solicitation message.
18b	The P-GW of SAEGW sends a Router Advertisement and include the globally unique /64 IPv6 prefix previously assigned.
19	The UE sends a SIP Re-Register once it successfully identifies it has changed access network to indicate the RAT change to the P-CSCF and assigned IP address is unchanged. UE will include 802.11 a/b/g/n in the PANI header. The SIP re-registration does not impact the way the P-CSCF does charging as charging is not used from the P-CSCF in IMS case.
15c CCR-u	P-GW of SAEGW to OCS: CCR-U. If the Online AVP is set in the CCA from the PCRF, the P-GW shall conditionally send a CCR-Update to the OCS to request online charging quota for the PDN session.
15d CCA-u	OCS to P-GW: CCA. The OCS responds with a CCA to the P-GW of SAEGW.

Step	Description
16b	<p>P-GW of SAEGW to ePDG: Create Bearer Request. The IMS PDN has one or more dedicated bearers established prior to handoff and the P-GW of SAEGW also sends Create Bearer Request to the ePDG. Note that Charging ID is not sent on S2b.</p> <p>Note If there is a collision and already one transaction is pending and handoff request is received, then handoff is rejected with message "Rejecting S2b/LTE Handoff as only one pending transaction is supported".</p>
16c	ePDG to P-GW: Create Bearer Response. The ePDG sends Create Bearer Response message
20	P-GW of SAEGW to S-GW of SAEGW: Delete Bearer Request. The P-GW sends the Delete Bearer Request (Linked EPS Bearer ID (if last bearer) or EPS Bearer ID, Cause (RAT changed from 3GPP to Non-3GPP)) to the S-GW. This message may be sent any time after message 13, the create session request.
21	<p>S-GW of SAEGW to MME: Delete Bearer Request. The S-GW of SAEGW sends the Delete Bearer Request (Linked EPS Bearer ID (if last bearer) or EPS Bearer ID, Cause (RAT changed from 3GPP to Non-3GPP)) to the MME.</p> <p>The MME releases the E-UTRAN bearers if not already released. The MME does not send Notify Request to HSS at this point, as the cause IE is RAT change to Non-3GPP. MME does not page the UE either or initiate any NAS signaling and remove the locally stored PDN state and does S1 context release to the eNodeB if it has not already been triggered by the eNodeB. For last PDN MME removes all locally stored UE state.</p>
22	MME to S-GW of SAEGW: Delete Bearer Response. The MME sends Delete Bearer Response to the S-GW of SAEGW.
23	S-GW of SAEGW to P-GW of SAEGW: Delete Bearer Response. The S-GW of SAEGW sends Delete Bearer Response to the P-GW of SAEGW.

Figure 86: SAEGW WiFi to LTE Handoff

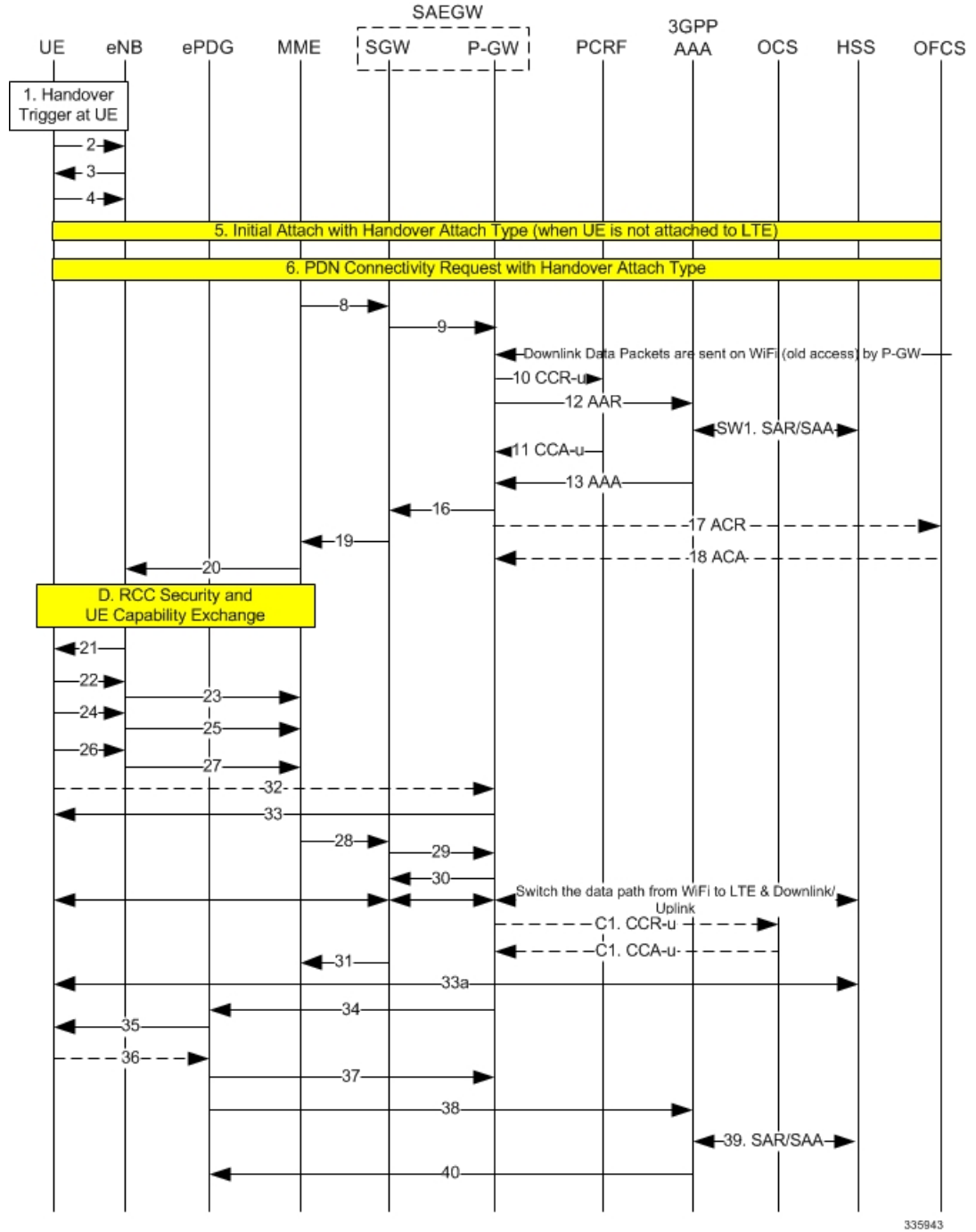

335943

Table 46: SAEGW WiFi to LTE Handoff Procedure

Step	Description
1	A handover trigger occurs at the UE.

Step	Description
2, 3	RRC Connection Request/Connection Setup. The UE and eNodeB exchange signaling to set up an RRC connection (5.3.3, TS 36.331).
4	RRC Connection Setup Complete [Attach Request]. The UE sends RRC Connection Setup Complete message to the eNodeB.
5	Attach Request from eNB to MME. The UE indicates in the Attach Request to LTE that this is a Handover Attach. The eNodeB selects the MME. The eNodeB forwards the Attach Request message in an Initial UE Message to the MME.
6	MME selects the same P-GW of SAEGW based on HSS provided PGW FQDN and sends the Create Session request.
8	The MME selects the PGW/SGW of SAEGW. The MME sends a Create Session Request to the SGW of SAEGW with RAT as EUTRAN and the handoff indicator set to TRUE.
9	The SGW of SAEGW sends a Create Session Request to the PDN GW in order to establish the handoff (handoffindicator is set to true). RAT type is E-UTRAN.
10	P-GW of SAEGW to PCRF CCR IP-CAN Session Modification Procedure. The PCEF sends a CC-Request (CCR) Command with CC-Request-Type set to UPDATE_REQUEST. The APN-AMBR is included in the QoS-information AVP.
12	The P-GW of SAEGW sends AAR to 3GPP-AAA and includes the RAT type of the new connection.
SW1. SAR/SAA	The 3GPP-AAA sends SAR to HSS to retrieve the user profile, the HSS returns an SAA. The P-GW-FQDN is not updated as the 3GPP-AAA is not registered for this user.
11	PCRF to P-GW of SAEGW: CCA IP-CAN Session modification Procedure. On receiving the CCR the PCRF shall send a CC-Answer (CCA) Command to install the PCC rules and event triggers for all configured and established bearers. The QoS-Information AVP contains APN-AMBR-UL and APN-AMBR-DL.
13	The 3GPP-AAA responds with AAA.
16	P-GW of SAEGW to S-GW of SAEGW: Create Session Response + Create Bearer Request. The P-GW of SAEGW responds with a Create Session Response message to the S-GW of SAEGW. The P-GW of SAEGW provides IPv6 Prefix. Subject to operator configuration the P-GW of SAEGW can begin to forward downlink data and the S-GW of SAEGW buffers any downlink data packets.
17	P-GW of SAEGW to OFCS: ACR. After the P-GW of SAEGW sends the PBA, the P-GW of SAEGW sends an ACR-Interim to the OFCS.
18	OFCS to P-GW of SAEGW: ACA. The OFCS responds with an ACA to the P-GW.
19	Create Session Response. The S-GW of SAEGW sends Create Session Response to the MME.

Step	Description
20	Initial Context Setup Request/Attach Accept. The Attach Accept is sent as NAS PDU in the Initial Context Setup Request from MME to eNodeB. Attach Accept message contains new GUTI.
D	These procedures occur independently of the location procedures. These procedures only apply to initial attach scenarios.
21	RRC Connection Re-configuration. The eNodeB sends the RRC Connection Reconfiguration message including the EPS Radio Bearer Identity to the UE, and the Attach Accept message to the UE. The APN is provided to the UE to notify it of the APN for which the activated default bearer is associated.
22	RRC Connection Re-configuration Complete. The UE sends the RRC Connection Reconfiguration Complete message to the eNodeB.
23	Initial Context Setup Response. The eNodeB sends Initial Context Setup Response to the MME.
24	Uplink Information Transfer. The UE sends an Uplink Information Transfer message.
25	Attach Complete. The eNodeB forwards the received Attach Complete message in an Uplink NAS Transport as part of NAS PDU.
26	Uplink Information Transfer. When the UE has received Activate dedicated EPS Bearer Context Request message in the Attach Accept message, the UE sends Activate Dedicated EPS Bearer Context Accept message in a Uplink Information Transfer message.
27	UL NAS Transport. The eNB passes the Activate Dedicated EPS Bearer Context Accept message received in Step 14.b, to the MME in a UL NAS Transport message. At this time, the uplink data can be sent on the dedicated bearer.
32	Router Solicitation. This step may happen any time after step 26. For IPv6 PDN, the UE may send a Router Solicitation to the P-GW.
33	Router Advertisement. This step may happen any time after step 29 if the UE requested IPv4v6 or IPv6 PDN type. On receipt of the RS or prior the P-GW of SAEGW sends a Router Advertisement and include the globally unique /64 IPv6 prefix previously assigned.
28	Modify Bearer Request / Create Bearer Response. On receiving both Initial Context Setup Response and Attach Complete, the MME sends a Modify Bearer Request message to the S-GW of SAEGW. The MME piggybacks the Modify Bearer Request message on the Create Bearer Response message.

Step	Description
29	<p>The S-GW of SAEGW processes each message independently. The S-GW of SAEGW forwards the Create Bearer Response to the P-GW. At this time, the P-GW of SAEGW can send downlink data on the dedicated bearer for the IMS traffic.</p> <p>Since Handover Indication is set to TRUE in the Modify Bearer Request, the S-GW of SAEGW sends Modify Bearer Request to the P-GW of SAEGW separately.</p> <p>Based on TS 23.401, the P-GW of SAEGW switches the downlink traffic to S5 upon receiving this message. However, subject to operator configuration, this switching occurs at Create Session Request above (C3).</p>
30	The P-GW of SAEGW sends Modify Bearer Response (Cause) message to the S-GW.
C1. CCR-u	P-GW of SAEGW to OCS: CCR-U. If the Online AVP is set in the CCA from the PCRF, the P-GW of SAEGW conditionally sends a CCR-Update to the OCS to request online charging quota for the PDN session.
C1. CCA-u	OCS to P-GW of SAEGW: CCA. The OCS responds with a CCA to the P-GW of SAEGW.
31	<p>The S-GW of SAEGW sends Modify Bearer Response to the MME. The S1 S-GW F-TEID is the same as the S1-U S-GW F-TEID sent in Create Session Response from the S-GW of SAEGW to the MME.</p> <p>The S-GW of SAEGW can now start sending downlink packets to eNB and the switching of the data path from WiFi to LTE occurs after the Modify Bearer Response.</p>
33a	SIP Re-registration RAT Change. The UE sends a SIP Re-Register to the P-CSCF to indicate that it detected a RAT change and assigned IP address remained unchanged.
34	P-GW of SAEGW to ePDG: Delete Bearer Request. The P-GW of SAEGW sends Delete Bearer Request to ePDG to disconnect the session.
35	ePDG to UE: IKEv2 Information Delete Request. The ePDG sends IKEv2 Informational Delete Request () to UE to disconnect the session.
34	UE to ePDG: IKEv2 Informational Delete Response. UE responds with IKEv2 Informational Delete Response () and initiates air interface resource release. This step is conditional and UE may not send this response.
37	ePDG to P-GW of SAEGW: Delete Bearer Response. The ePDG sends Delete Bearer Response to the P-GW.
38	ePDG to AAA: Session Termination Request. The ePDG sends STR to the 3GPP AAA.
39	<p>AAA to HSS: Server Assignment Request. The AAA sends Server-Assignment-Request to de-register.</p> <p>HSS to AAA: SAA. The HSS sends Server-Assignment-Answer.</p>
40	AAA to ePDG: Session Termination Answer. The AAA sends STA to the ePDG.

Standards Compliance

This section lists the industry-standards and references that were used in developing the GTP-based S2b interface implementation on the P-GW and SAEGW:

The following standards and references were used in developing the GTP-based S2b interface support feature.

- 3GPP TS 23.003-a.1.0 Numbering, addressing and identification
- 3GPP TS 23.234-a.0.0, 3GPP system to Wireless Local Area Network (WLAN) Interworking
- 3GPP TS 23.261-a.1.0, IP flow mobility and seamless Wireless Local Area Network (WLAN) Offload
- 3GPP TS 23.401: GPRS Enhancement for E-UTRAN Access
- 3GPP TS 23.402-a.4.0 Architecture Enhancements for non-3GPP Accesses
- 3GPP TS 24.302-a.4.0: Access to the 3GPP Evolved Packet Core (EPC) via non-3GPP access networks.
- 3GPP TS 24.312-a.3.0 Access Network Discovery and Selection Function (ANDSF) Management Object (MO)
- 3GPP TS 29.273-a.3.0 Evolved Packet System (EPS); 3GPP EPS AAA interfaces
- 3GPP TS 29.274- Evolved General Packet Radio Service (GPRS) Tunneling Protocol for Control plane (GTPv2-C); Stage 3
- 3GPP TS 33.234-a.0.0 Wireless Local Area Network (WLAN) interworking security
- 3GPP TS 33.402-a.0.0 Security aspects of non-3GPP accesses
- IETF RFC 3588: Diameter Base Protocol.
- IETF RFC 3602: The AES-CBC Cipher Algorithm and Its Use with IPSec
- IETF RFC 3715 IPSec-Network Address Translation (NAT) Compatibility Requirements
- IETF RFC 3748: Extensible Authentication Protocol (EAP)
- IETF RFC 3948: UDP Encapsulation of IPSec ESP Packets.
- IETF RFC 4187: Extensible Authentication Protocol Method for 3rd Generation Authentication and Key Agreement (EAP-AKA)
- IETF RFC 4303: IP Encapsulating Security Payload (ESP).
- IETF RFC 4306: Internet Key Exchange Protocol Version 2
- IETF RFC 4739: Multiple Authentication Exchange in IKEv2 protocol
- IETF RFC 5996 Internet Key Exchange Protocol Version 2 (IKEv2)

How the S2a Architecture Works

This section provides information that describes the S2a interface architecture on the standalone P-GW and SAEGW.

Standalone P-GW and SAEGW Architecture for S2a Interface Support

Diagrams for the S2a interface architecture for the standalone P-GW and SAEGW appear below.

The S2a interface connects the standalone P-GW and P-GW of the SAEGW with the HSGW of the eHRPD. Specifically, the S2a interface supports the bearer interface by providing signaling and mobility support between a trusted non-3GPP access point (HSGW) and the standalone P-GW or P-GW of the SAEGW. It is based on Proxy Mobile IP but also supports Client Mobile IPv4 FA mode which allows connectivity to trusted non-3GPP IP access points that do not support PMIP.

Figure 87: S2a Interface Architecture for the Standalone P-GW

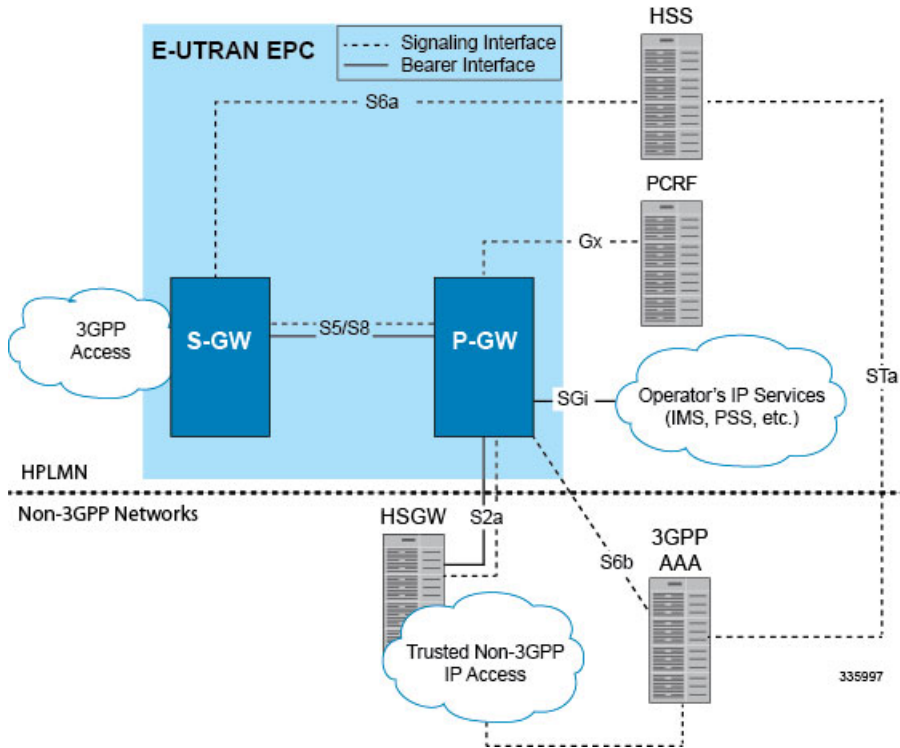
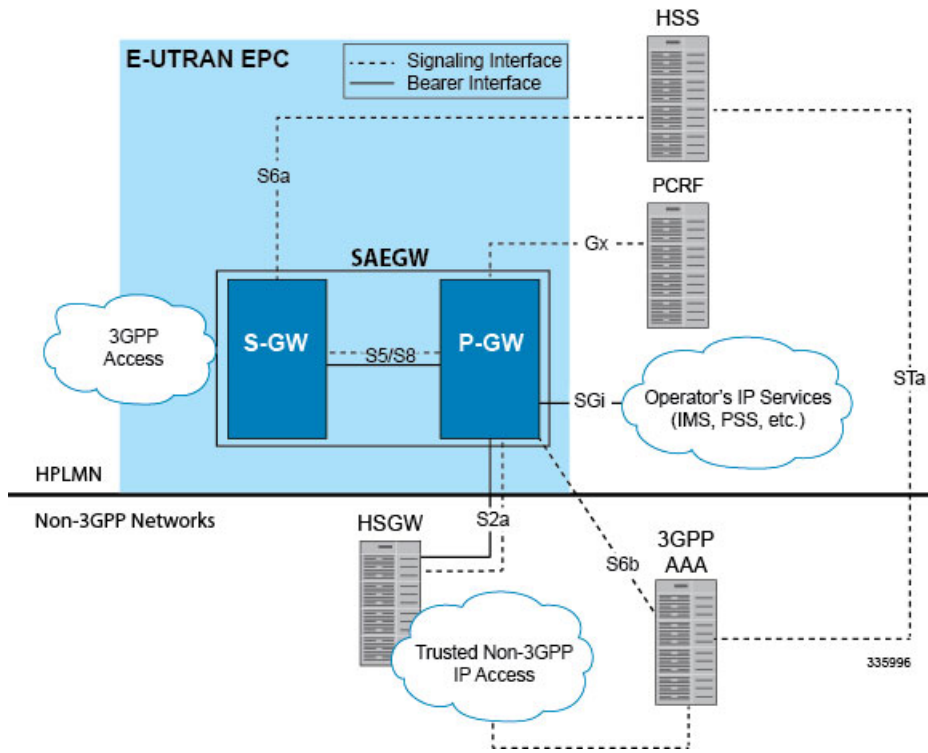

Figure 88: S2a Interface Architecture for the SAEGW



Limitations on S2a Interface Support on the P-GW and SAEGW

Note the following limitations of the GTP-based S2a interface implementation on the P-GW and SAEGW:

- Access Type technologies supported are WiFi and LTE.
- Interfaces supported include:
 - S6b
 - Gy
 - Rf
 - Gx
 - GTPv2

Standalone P-GW S2a Call Flows

The following call flow diagrams describe the basic functionality of the S2a interface when deployed in a standalone P-GW architecture.

Figure 89: S2a Initial Attach on Standalone P-GW

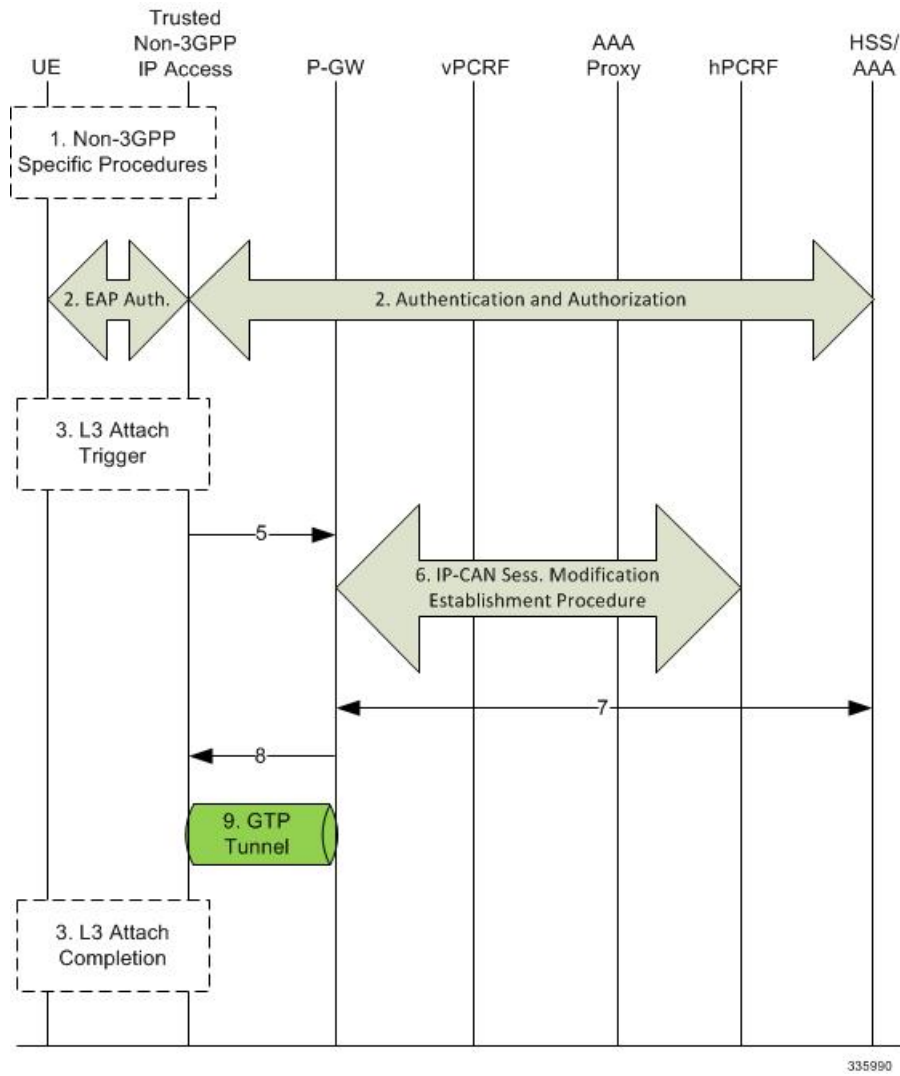
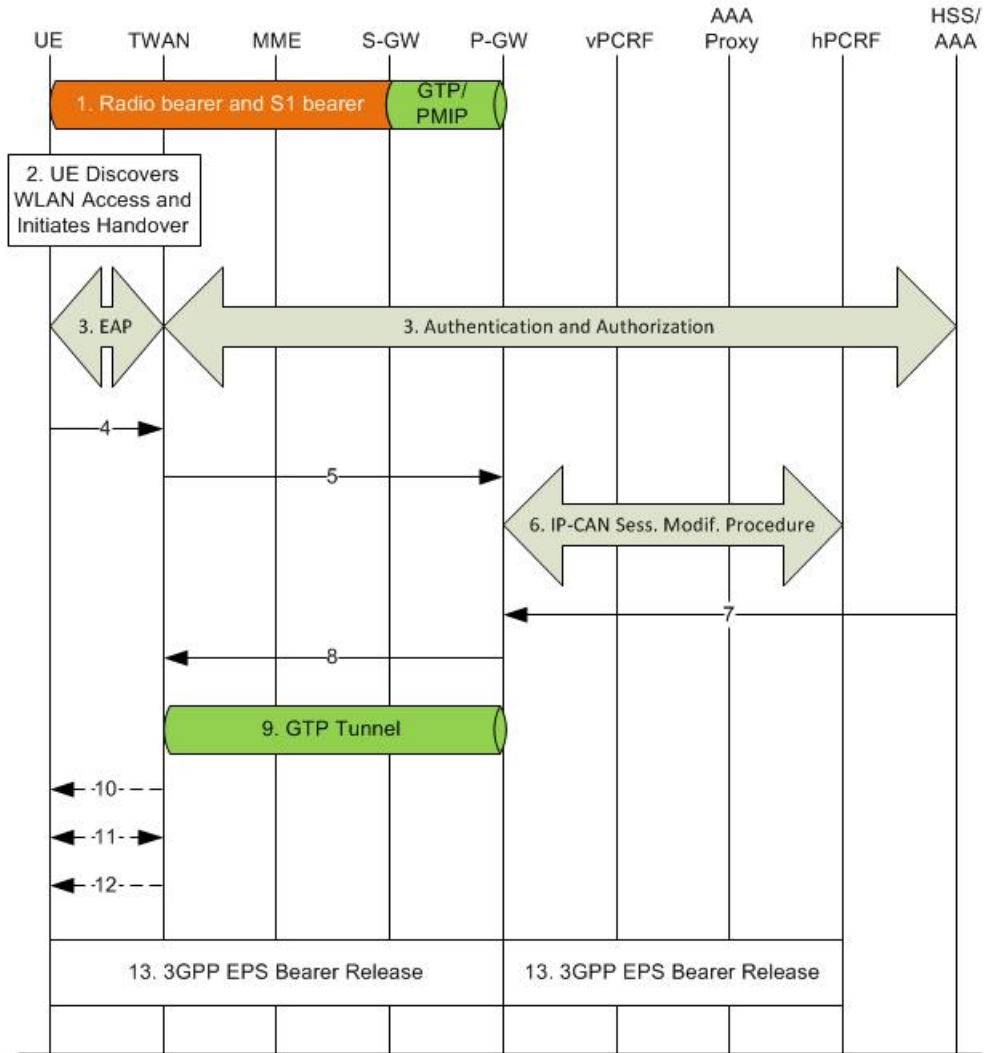

Table 47: S2a Initial Attach on Standalone P-GW

Step	Description
1	
2	
3	
4	

Step	Description
5	The Trusted non-3GPP IP Access sends a Create Session Request message to the P-GW. The RAT type indicates the non-3GPP IP access technology type. The PDN type shall be set based on the requested IP address types and subscription profile in the same way as the PDN type is selected during the E-UTRAN Initial Attach.
6	The P-GW initiates the IP-CAN Session Establishment Procedure with the PCRF.
7	The selected P-GW informs the 3GPP AAA Server of its P-GW identity and the APN corresponding to the UE's PDN Connection. The message includes information that identifies the PLMN in which the PDN GW is located. This information is registered in the HSS.
8	The P-GW returns a Create Session Response message to the TWAN, including the IP address(es) allocated for the UE.
9	The GTP tunnel is set up between the TWAN and the P-GW.
10	Initial Attach is complete.

Figure 90: S2a LTE-to-WiFi Handover on Standalone P-GW



335991

Table 48: S2a WiFi-to-LTE Handover on Standalone P-GW

Step	Description
1	
2 - 4	The UE discovers WLAN access and initiates a handover. The TWAN takes authorization from the AAA server.

Step	Description
5	The TWAN sends a Create Session Request (IMSI, APN, RAT type) message to the P-GW. The RAT type WLAN indicates the non-3GPP IP access technology type. The TWAN does not set the 'Handover Indication' bit. Instead, based on the IMSI, APN and RAT type the P-GW determines that it is potential handover from the TWAN. The P-GW re-allocates the same IPv4 address and/or IPv6 address that was assigned to the UE while it was connected to 3GPP IP access.
6	The P-GW executes a PCEF-Initiated IP-CAN Session Modification Procedure with the PCRF with the RAT type as WLAN.
7	The P-GW informs the 3GPP AAA Server of its P-GW identity and the APN corresponding to the UE's PDN and obtains authorization information from the 3GPP AAA Server. The 3GPP AAA Server decides whether or not to update the P-GW identification according to the UE capability, which has been provided at the authentication phase.
8	The P-GW responds with a Create Session Response to the TWAN. The Create Session Response contains the IPv4 address and/or the IPv6 address assigned to the UE while it was connected to the 3GPP IP access.
9	The GTP tunnel is setup between TWAN and the P-GW.
10	
11	
12	
13	The P-GW initiates the P-GW Initiated Bearer Deactivation procedure as defined in TS 23.401 [6], clause 5.4.4.1 for GTP-S5/S8.

Figure 91: S2a WiFi-to-LTE Handover on Standalone P-GW

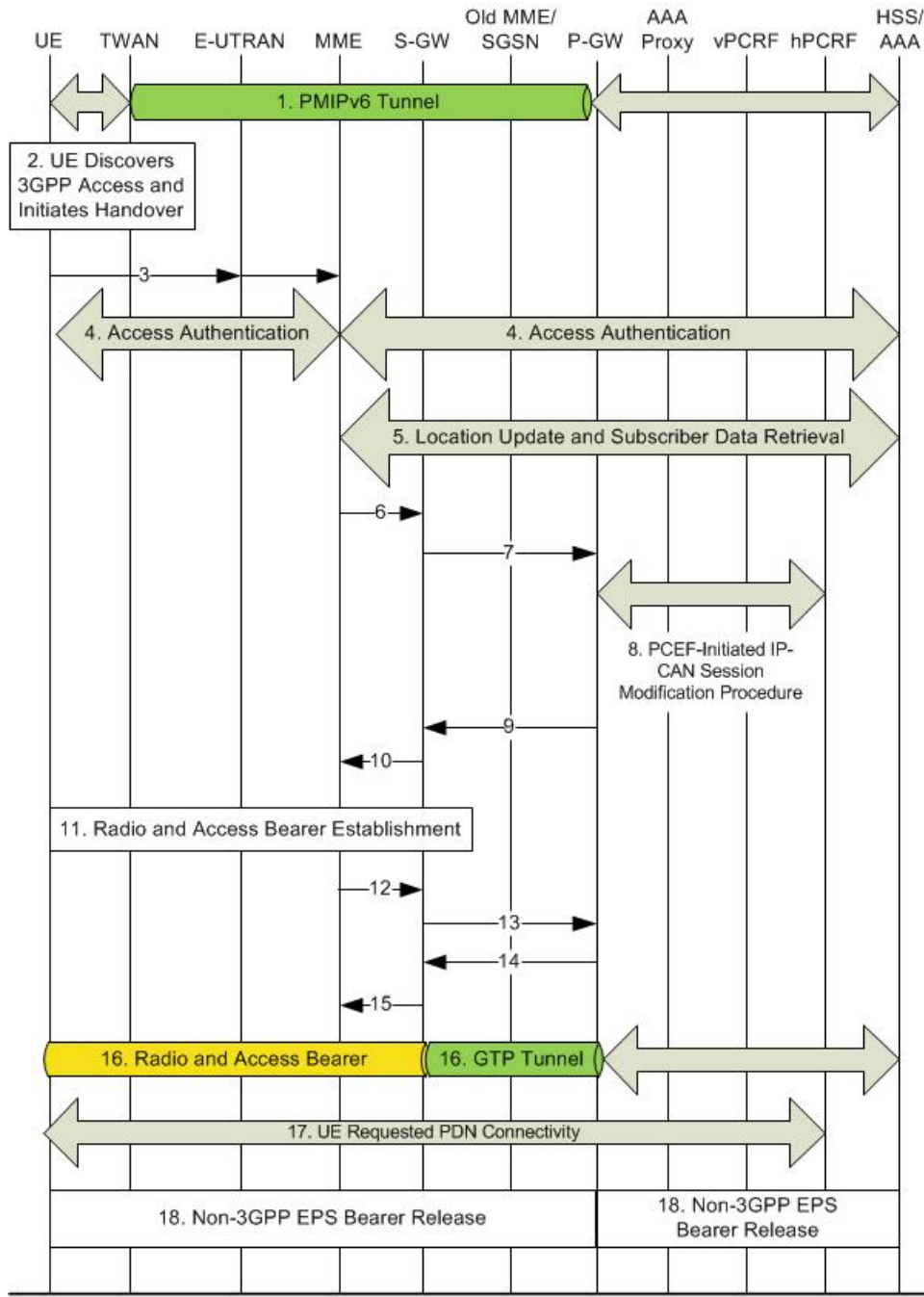

335992

Table 49: S2a WiFi-to-LTE Handover on Standalone P-GW

Step	Description
1	

Step	Description
2	
3	
4	
5	
6	
7	
8	
9	
10	
11	
12	
13	
14	
15	
16	
17	
18	

SAEGW S2a Call Flows

The call flow diagrams in this section describe the basic functionality of S2a interface support on the SAEGW, including:

- Initial Attach
- LTE-to-WiFi Handover
- WiFi-to-LTE Handover

Figure 92: S2a Initial Attach on the SAEGW

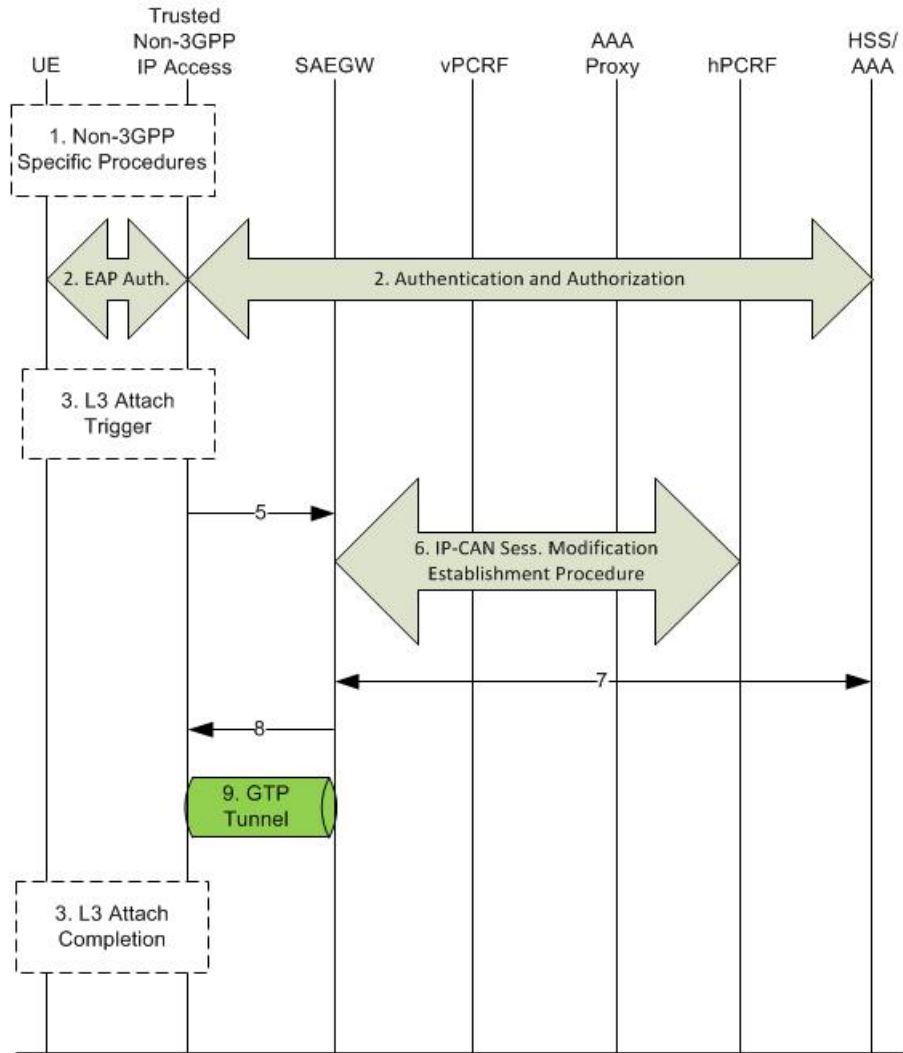

335994

Table 50: S2a Initial Attach on the SAEGW

Step	Description
1	
2	
3	
4	

Step	Description
5	<p>The Trusted non-3GPP IP Access sends a Create Session Request (CSReq) message to the P-GW of the SAEGW. The RAT type indicates the non-3GPP IP access technology type. The PDN type shall be set based on the requested IP address types and subscription profile in the same way as the PDN type is selected during the E-UTRAN Initial Attach.</p> <p>The P-GW of the SAEGW creates a new entry in its bearer context table and generates a Charging Id. The new entry allows the P-GW of the SAEGW to route user plane PDUs between the Trusted non-3GPP IP Access Network and the packet data network and to start the charging process.</p>
6	The P-GW initiates the IP-CAN Session Establishment Procedure with the PCRF.
7	The selected P-GW of the SAEGW informs the 3GPP AAA Server of its P-GW identity and the APN corresponding to the UE's PDN Connection. The message includes information that identifies the PLMN in which the P-GW is located. This information is registered in the HSS.
8	The P-GW returns a Create Session Response (CSResp) message to the TWAN, including the IP address(es) allocated for the UE.
9	<p>The GTP tunnel is set up between the TWAN and the P-GW.</p> <p>Initial Attach is completed.</p>

Figure 93: S2a LTE-to-WiFi Handover on the SAEGW

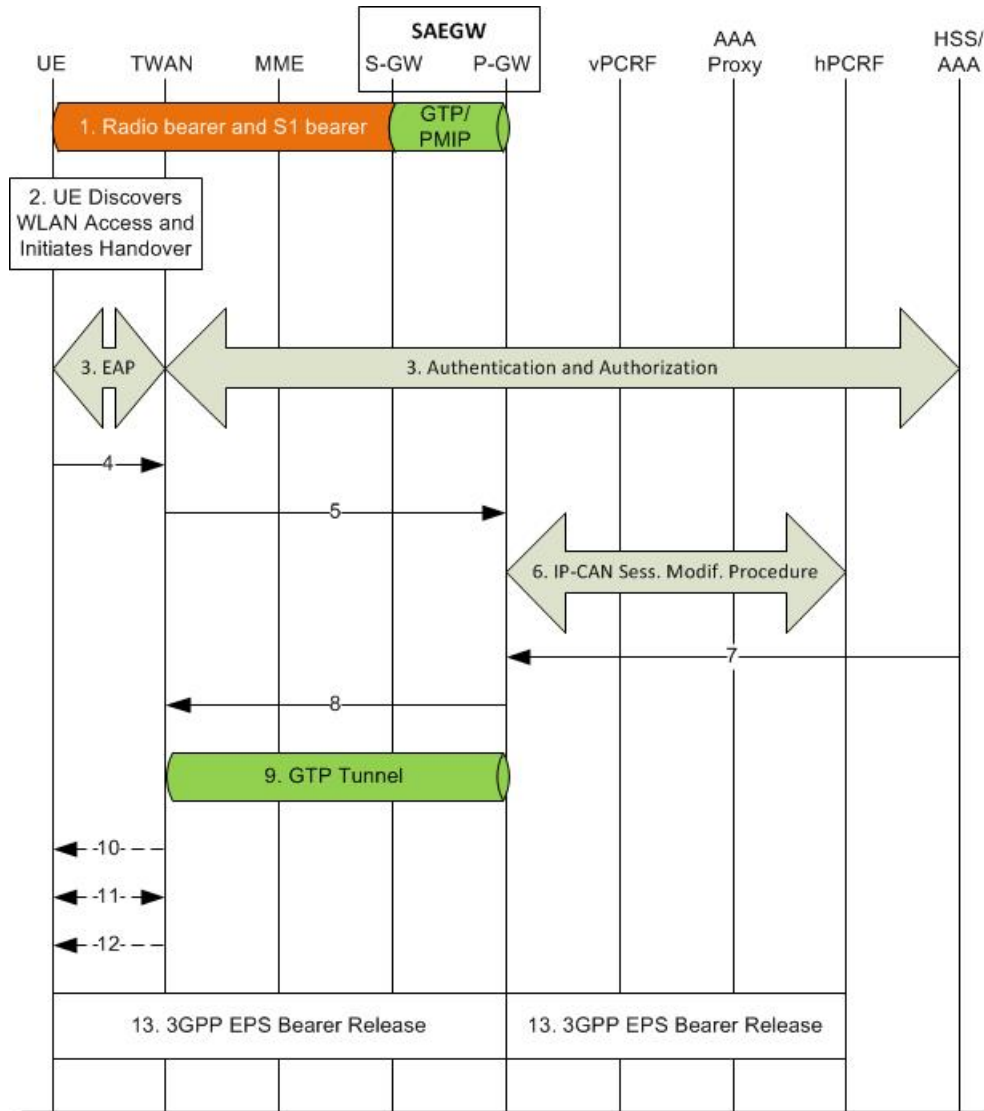

335994

Table 51: S2a LTE-to-WiFi Handover on the SAEGW

Step	Description
1	
2 - 4	In Steps 2-4, the UE discovers WLAN access and initiates a handover. The TWAN takes authorization from the AAA server.

Step	Description
5	<p>The TWAN sends a Create Session Request (including IMSI, APN, RAT type) message to the P-GW of the SAEGW</p> <p>The RAT type WLAN indicates the non-3GPP IP access technology type. The TWAN does not set the 'Handover Indication' bit. Instead, based on the IMSI, APN and RAT type the P-GW of the SAEGW determines that it is a potential handover from the TWAN.</p> <p>The P-GW of the SAEGW re-allocates the same IPv4 address and/or IPv6 address assigned to the UE while it was connected to 3GPP IP access.</p>
6	<p>The P-GW of the SAEGW executes a PCEF-Initiated IP-CAN Session Modification Procedure with the PCRF with RAT type as WLAN.</p>
7	<p>The P-GW of the SAEGW informs the 3GPP AAA Server of its PDN GW identity and the APN corresponding to the UE's PDN and obtains authorization information from the 3GPP AAA Server.</p> <p>The 3GPP AAA Server decides whether or not to update PDN GW identification according to the UE capability, which was provided at the authentication phase.</p>
8	<p>The P-GW of the SAEGW responds with a Create Session Response to the TWAN. The Create Session Response contains the IPv4 address and/or the IPv6 address assigned to the UE while it was connected to the 3GPP IP access.</p>
9	<p>A GTP tunnel is setup between TWAN and the P-GW of the SAEGW.</p>
10	
11	
12	
13	<p>The P-GW of the SAEGW begins the P-GW Initiated Bearer Deactivation procedure as defined in TS 23.401 [6], clause 5.4.4.1 for GTP-S5/S8 interfaces.</p>

Figure 94: S2a WiFi-to-LTE Handover on the SAEGW

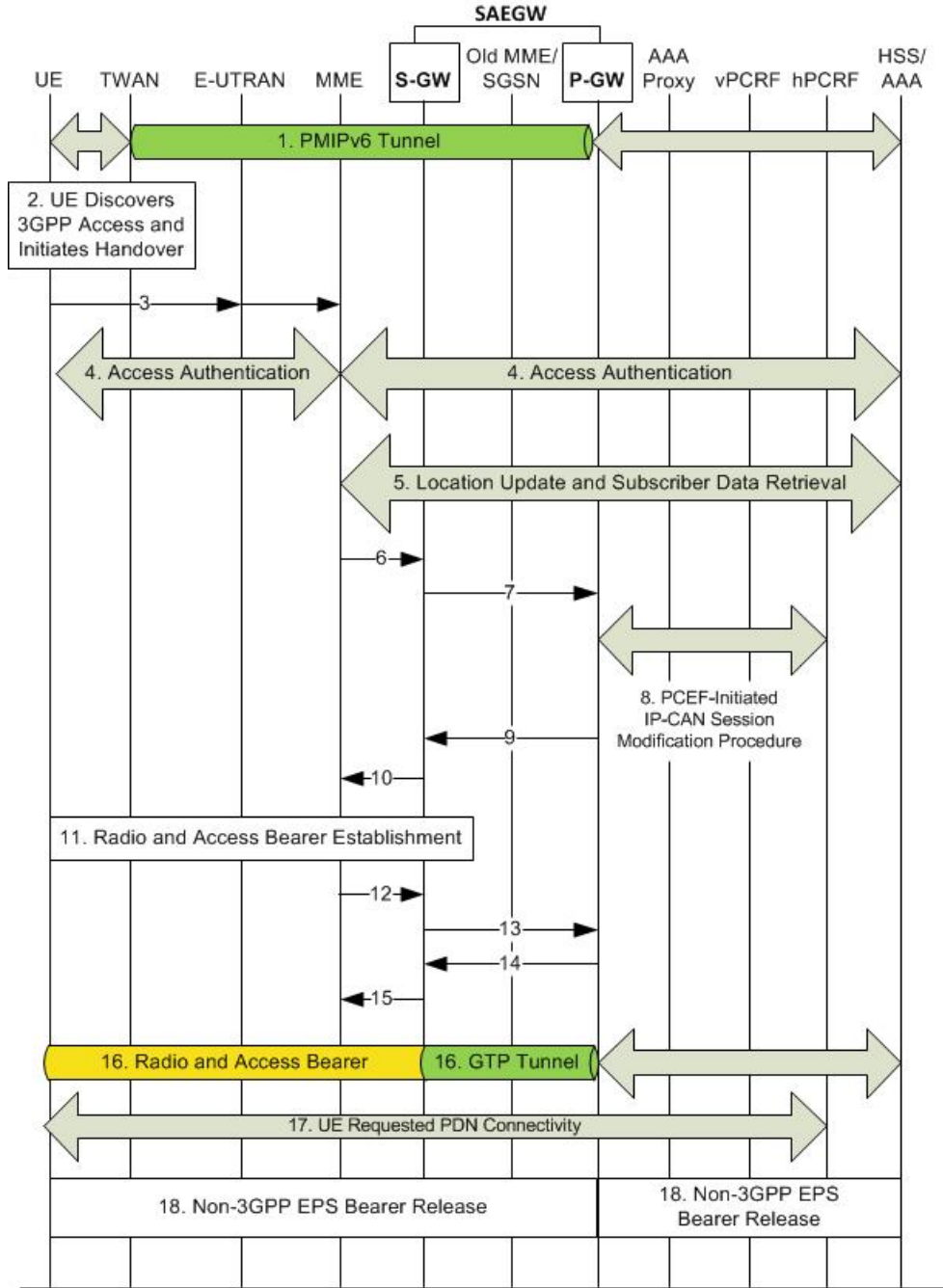

335995

Table 52: S2a WiFi-to-LTE Handover on the SAEGW

Step	Description
1	

Step	Description
2	
3	
4	
5	
6	
7	
8	
9	
10	
11	
12	
13	
14	
15	
16	
17	
18	

Configuring the GTP-based S2b Interface on the P-GW and SAEGW

This section describes how to configure the GTP-based S2b interface support feature.

Configuring GTP-based S2b Interface Support

Use the following example to configure GTP-based S2b interface support on the P-GW and SAEGW.



Important

GTP-based S2a/S2b interface support on the P-GW and SAEGW is a license-controlled feature. Contact your Cisco account or support representative for licensing details.



Important If you modify the **interface-type** command, the parent service (service within which the eGTP/GTP-U service is configured) will automatically restart. Service restart results in dropping of active calls associated with the parent service.

```
config
  context ingress_context_name
    egtp-service egtp_service_name
      interface-type interface-pgw-ingress s2b
    end
```

Disable S2b interface support by entering the following commands:

```
config
  context ingress_context_name
    egtp-service egtp_service_name
      interface-type interface-pgw-ingress
    end
```

Verifying the Configuration

This section describes how to verify the GTP-based S2a/S2b interface configuration on the P-GW and SAEGW.

Use the **show configuration** command from Exec Mode to verify that the configuration is active. Look for the eGTP service configuration section in the output:

```
egtp-service EGTP
  interface-type interface-pgw-ingress s2a s2b
```

Once the S2b license is installed and active, run a WiFi Initial Attach Call to check that a successful call is setup. From Exec Mode, use the **show subscribers all** command to verify that the call was successful.

Monitoring the GTP-based S2b Interface Feature

This section provides commands that operators can use to monitor the GTP-based S2b interface feature on the P-GW and SAEGW.

GTP-based S2b Interface Show Commands

This section provides information regarding show commands and/or their outputs for GTP-based S2b interface support.

show pgw-service statistics all

For S2b interface support on the standalone P-GW: This command provides statistics on the number of attempts, failures, and successes for the following S2b interface functions:

- S2bGTP-to-LTE handovers
- LTE-to-S2bGTP handovers

show subscribers epdg-address

This command provides information on the S2b P-GW subscribers connected to the ePDG over the S2b interface.

show subscribers saegw-only epdg-address

This command shows information related to subscribers of the P-GW of the SAEGW connected to a specific ePDG over the S2b interface.

show subscribers saegw-only interface-type S2bGTP

This command shows information related to GTP P-GW subscribers of the SAEGW connected via the S2b interface.

show subscribers summary pgw-address

This command provides information on the number of Active and Dormant GTP S2b IPv4 and IPv6 subscribers.

show subscribers pgw-only full all

For S2b interface support on the standalone P-GW: Use this command to view S2b call related information for P-GW subscribers. The output will provide the following S2b specific information:

- Interface Type (S2b PGW GTP-C interface)
- MAC Address
- ePDG c-teid (ePDG control tunnel endpoint identifier)
- ePDG u-teid (ePDG bearer tunnel endpoint identifier)
- ePDG c-addr (ePDG control IP address)
- ePDG u-addr (ePDG bearer IP address)

show subscribers pgw-only epdg-address

For S2b interface support on the standalone P-GW: Use this command to view all S2b information for all the subscribers' sessions that exist on the P-GW for a specific ePDG. The ePDG is specified by the epdg-address (in IPv4 or IPv6 address format).

show subscribers summary epdg-address

For S2b interface support on the standalone P-GW: Use this command to view statistics for all the subscribers' sessions that exist on the P-GW that belong to the S2b interface on a specific ePDG. The ePDG is specified by the epdg-address.

show subscribers summary interface-type S2bGTP

For S2b interface support on the standalone P-GW: View the number of active and dormant subscriber sessions on the P-GW that belong to the S2b interface.

show subscribers saegw-only full all

For S2b interface support on the SAEGW: This command provides S2b call-related information for P-GW subscribers, including:

show saegw-service statistics all function pgw

- Access Tech
- Interface Type
- Access Point MAC Address
- sgw c-teid
- ePDG c-teid
- sgw c-addr
- ePDG c-addr
- sgw u-teid
- ePDG u-teid
- sgw u-addr
- ePDG u-addr

show saegw-service statistics all function pgw

For S2b interface support on the SAEGW: This command provides statistics related to successes, failures and attempts for various S2bGTP handovers for all P-GW SAEGW services, including:

- S2bGTP-to-LTE handover
 - Attempted
 - Succeeded
 - Failed
- LTE-to-S2bGTP handover
 - Attempted
 - Succeeded
 - Failed

Monitoring the GTP-based S2a Interface Feature

This section provides information on how to monitor the GTP-based S2a interface feature.

GTP-based S2a Interface Show Commands

This section provides information regarding show commands and/or their outputs for GTP-based S2a interface support.

show pgw-service statistics all

The output of this command has been enhanced to provide statistics on S2aGTP-to-LTE and LTE-to-S2aGTP handovers. It records the total number of handover attempts, and the number of attempts that succeeded and failed.

show saegw-service statistics all

The output of this command provides information related to subscribers, bearers, and PDNs on the S2a interface.

show saegw-service statistics all function-pgw

The output of this command provides subscriber, PDN and handover statistics for the P-GW function of the SAEGW on the S2a interface.

show session-subsystem facility sessmgr service-type pgw-ingress

The output of this command has been enhanced to provide S2a interface session information to troubleshoot subscriber session problems and for general monitoring for orphaned sessions. If this command is entered with no keywords, the information displayed is cumulative for all sessions facilitated by the system.

show subscribers pgw-only full all

The output of this command has been enhanced to show S2a call-related information, including access technology, TWAN, and TEID information.

show subscribers saegw-only full all

The output of this command contains subscriber information related to the S2a interface, including subscriber ID information, TEID and address information, and input/output packets recorded and dropped.

show subscribers saegw-only interface-type S2aGTP

The **S2aGTP** keyword has been added to this command to enable operators to view detailed information for S2a subscriber sessions, including call code, CALLID, IMSI/IMEI, APN and Time-Idle.

show subscribers summary interface-type S2aGTP

The output provides interface type details on subscribers connected via the S2a interface. The output provides interface type details on subscribers connected via the S2a interface. Information is given for both IPv4, IPv6, and IPv4v6 interfaces.

show subscribers summary pgw-address

The output of this command contains S2a subscriber information for the specified P-GW. Interface information is included for IPv4, IPv6 and IPv4v6 interfaces.

show subscribers summary pgw-address



CHAPTER 22

3GPP R12 GTP-C Load and Overload Control Support on the P-GW, SAEGW, and S-GW

This chapter describes the 3GPP Release 12 GTP-C Load and Overload Control feature on the P-GW, SAEGW, and S-GW.

- [Feature Description, on page 483](#)
- [How It Works, on page 484](#)
- [Creating and Configuring a 3GPP R12 GTP-C Load Control Profile, on page 485](#)
- [Creating and Configuring a 3GPP R12 GTP-C Overload Control Profile, on page 490](#)
- [Monitoring and Troubleshooting the 3GPP R12 GTP-C Load and Overload Control Feature, on page 497](#)

Feature Description

This section describes the 3GPP R12 GTP-C Load and Overload Control feature.



Important Use of the 3GPP R12 Load and Overload Control feature requires that a valid license key be installed. Contact your Cisco account or support representative for information on how to obtain a license.

The 3GPP R12 GTP-C Load and Overload Control feature is a licensed, optional feature which allows a GTP control plane node to send its load information to a peer GTP control plane node which the receiving GTP control plane peer node uses to augment existing GW selection procedure for the P-GW and S-GW. Load information reflects the operating status of the resources of the originating GTP control plane node.

Nodes using GTP control plane signaling may support communication of overload control information in order to mitigate overload situations for the overloaded node through actions taken by the peer node(s). This feature is supported over the S4, S11, S5 and S8 interfaces via the GTPv2 control plane protocol.

A GTP-C node is considered to be in overload when it is operating over its nominal capacity resulting in diminished performance (including impacts to handling of incoming and outgoing traffic). Overload control information reflects an indication of when the originating node has reached such a situation. This information, when transmitted between GTP-C nodes, may be used to reduce and/or throttle the amount of GTP-C signaling traffic between these nodes. As such, the overload control information provides guidance to the receiving node to decide upon the correct actions, which leads to mitigation towards the sender of the information.

To summarize, load control and overload control can be described in this manner:

- **Load Control:** Load control enables a GTP-C entity (for example, an P-GW/SAEGW/S-GW) to send its load information to a GTP-C peer (for example, an MME/SGSN, ePDG, TWAN) to adaptively balance the session load across entities supporting the same function (for example, an S-GW cluster) according to their effective load. The load information reflects the operating status of the resources of the GTP-C entity.
- **Overload Control:** Overload control enables a GTP-C entity becoming or being overloaded to gracefully reduce its incoming signaling load by instructing its GTP-C peers to reduce sending traffic according to its available signaling capacity to successfully process the traffic. A GTP-C entity is in overload when it operates over its signaling capacity, which results in diminished performance (including impacts to handling of incoming and outgoing traffic).

Load and Overload Factor Calculation Enhancement

In capacity testing and also in customer deployments it was observed that the chassis load factor for the 3GPP R12 Load and Overload Support feature was providing incorrect values even when the sessmgr card CPU utilization was high. The root cause is that when the load factor was calculated by taking an average of CPU utilization of sessmgr and demux cards, the demux card CPU utilization never increased more than the sessmgr card CPU utilization. As a result, the system did not go into the overload state even when the sessmgr card CPU utilization was high.

The 3GPP R12 Load/Overload Control Profile feature has been enhanced to calculate the load factor based on the higher value of similar types of cards for CPU load and memory. If the demux card's CPU utilization value is higher than the sessmgr card's CPU utilization value, then the demux card CPU utilization value is used for the load factor calculation.

A new CLI command, **gtpc-system-param-poll interval**, is introduced to configure different polling intervals for the resource manager so that the demuxmgr can calculate the load factor based on different system requirements.

Relationships to Other Features

Note the following before configuring the GTP R12 GTP-C Load and Overload Control feature:

- One of the following services must be configured on the node before GTP-C Load and Overload Control can be configured.
 - P-GW
 - SAEGW
 - S-GW
- Once configured, the GTP-C Load and Overload Control profiles must be associated with a P-GW, SAEGW, or S-GW service to function properly in the network.

How It Works

The node periodically fetches various parameters (for example, License-Session-Utilization, System-CPU-Utilization, and System-Memory-Utilization), which are required for Node level load control information. The node then calculates the load/overload control information itself either based on the weighted factor provided by the user or using the default weighted factor.

Node level load control information is calculated every 30 seconds. The resource manager calculates the system-CPU-utilization and System-Memory-Utilization at a systems level.

For each configured service, load control information can be different. This can be achieved by providing a weightage to the number of active session counts per service license, for example, [(number of active sessions per service / max session allowed for the service license) * 100].

The node's resource manager calculates the system-CPU-utilization and System-Memory-Utilization at a systems level by averaging CPU and Memory usage for all cards and which might be different from that calculated at the individual card level.

Creating and Configuring a 3GPP R12 GTP-C Load Control Profile

This section describes how to create and configure a 3GPP R12 GTP-C load control profile.

Configuration Overview

Creating and configuring a 3GPP R12 GTP-C load control profile consists of the following procedures:

-
- Step 1** Create a load control profile. Refer to [Creating the GTP-C R12 Load Control Profile, on page 485](#).
 - Step 2** Configure the load control weightage settings. Refer to [Configuring the 3GPP R12 Load Control Profile Weightage Settings, on page 486](#).
 - Step 3** Configure the load control inclusion frequency. Refer to [Configuring the 3GPP R12 Load Control Profile Inclusion Frequency, on page 486](#).
 - Step 4** P-GW Only. Configure the load control threshold. Refer to [Configuring the 3GPP R12 Load Control Threshold, on page 487](#).
 - Step 5** Configure load control information handling. Refer to [Configuring 3GPP R12 Load Control Information Handling, on page 487](#).
 - Step 6** Configure load control information publishing. Refer to [Configuring 3GPP R12 Load Control Information Publishing, on page 487](#).
 - Step 7** Configure the 3GPP R12 GTP-C Polling Parameter Interval. Refer to [Configuring the 3GPP R12 GTP-C Polling Parameter Interval, on page 488](#).
 - Step 8** Associate the load control profile with a P-GW, SAEGW, or S-GW service. Refer to [Associating the 3GPP R12 Load Control Profile with a P-GW, SAEGW, or S-GW Service., on page 488](#).
 - Step 9** Verify the configuration settings. Refer to [Verifying the 3GPP R12 Load Control Configuration , on page 489](#).
 - Step 10** Save the configuration. Refer to [Saving the Configuration, on page 490](#).
-

Creating the GTP-C R12 Load Control Profile

Use the following example to create a load control profile on the P-GW/SAEGW/S-GW:

```
config
  gtpc-load-control-profile profile_name
end
```

Notes:

- The profile name must be an alphanumeric string from 1 to 64 characters in length.

- Once you have created the load control profile, you will enter *GTP-C Load Control Profile Configuration Mode*.

Configuring the 3GPP R12 Load Control Profile Weightage Settings

This section describes how to set weightage percentages for system CPU, memory, and license session utilization as part of a GTP-C load control profile configuration. These settings constitute the basic load control profile for this network element. These parameters allow the P-GW/S-GW/SAEGW to send its load information to a peer GTP control plane node which the receiving GTP control plane peer node uses to augment existing GW selection procedures for the P-GW and S-GW. Load information reflects the operating status of the resources of the originating GTP control plane node.

Use the following example to configure the load control profile weightage settings on the P-GW/SAEGW/S-GW:

```
config
  gtpc-load-control-profile profile_name
  weightage system-cpu-utilization percentage system-memory-utilization
percentage license-session-utilization percentage
end
```

Notes:

- **system-cpu-utilization *percentage***: Configures system CPU utilization weightage as a percentage of 100. *percentage* must be an integer from 0 to 100. The default is 40.
- **system-memory-utilization *percentage***: Configures system memory utilization weightage as a percentage of 100. *percentage* must be an integer from 0 to 100. The default is 30.
- **license-session-utilization *percentage***: Configures license session utilization weightage as a percentage of 100. *percentage* must be an integer from 0 to 100. The default is 30.



Important All parameters must be specified. The total of all three parameter settings should equal, but not exceed, 100.

Configuring the 3GPP R12 Load Control Profile Inclusion Frequency

This section describes how to set the parameters that determine the inclusion frequency of the Load Control Information Element (LCI) for a GTP-C Load Control Profile configuration. The LCI is a 3GPP-specific Information Element that is sent to peers when a configured threshold is reached. This parameter specifies how often the operator wants to send this information to the node's peers.

Use the following example to configure the load control profile inclusion frequency on the P-GW/SAEGW/S-GW.

```
config
  gtpc-load-control-profile profile_name
  inclusion-frequency { advertisement-interval interval_in_seconds |
change-factor change_factor }
end
```

Notes:

- **inclusion frequency:** Configures parameters to determine the inclusion frequency of the LCI.
- **advertisement-interval** *interval_in_seconds*: Configures advertisement-interval for the LCI in seconds. This specifies how often load control information should be sent to the peers. If configured to 0, the node will send load control information in each and every outgoing message to the peers. *interval_in_seconds* must be an integer from 0 to 3600. The default is 300.
- **change-factor** *change_factor*: Configures the change factor for the load control profile. If the load control change factor changes by the configured factor, whether it is an increase or decrease in load, the load control information is sent to the peers. This information is only sent to the peers when the load factor changes by the factor configured. *change_factor* must be an integer from 1 to 20. The default is 5.

Configuring the 3GPP R12 Load Control Threshold

This section describes how to configure the minimum threshold value above which P-GW-provided load control information should be utilized for calculating the P-GW effective weight during initial node selection.

Use the following example to configure Load Control Profile threshold on the P-GW.

```
config
  gtpc-load-control-profile profile_name
    threshold time_in_seconds
  end
```

Notes:

- The default threshold value is 50.

Configuring 3GPP R12 Load Control Information Handling

The handling of load control information for the home or visited PLMN can be enabled/disabled via this procedure.

Use the following example to enable/disable load control profile information handling on the SAEGW/S-GW/P-GW.

```
config
  gtpc-load-control-profile profile_name
    load-control-handling { home | visited }
    no load-control-handling { home | visited }
  end
```

Notes:

- **no** disables load-control-handling for the specified option.

Configuring 3GPP R12 Load Control Information Publishing

The publishing of load control information can be enabled/disabled for the home or visited PLMN.

Use the following example to enable/disable load control profile information publishing on the P-GW/SAEGW/S-GW.

```

config
  gtpc-load-control-profile profile_name
    load-control-publishing { home | visited }
    no load-control-publishing { home | visited }
  end

```

Notes:

- **no** disables load control profile information publishing for the specified option.

Configuring the 3GPP R12 GTP-C Polling Parameter Interval

In capacity testing and also in customer deployments it was observed that the chassis load factor for the 3GPP R12 Load and Overload Support feature was providing incorrect values even when the sessmgr card CPU utilization was high. The root cause is that when the load factor was calculated by taking an average of CPU utilization of sessmgr and demux cards, the demux card CPU utilization never increased more than the sessmgr card CPU utilization. As a result, the system did not go into the overload state even when the sessmgr card CPU utilization was high.

The 3GPP R12 Load/Overload Control Profile feature has been enhanced to calculate the load factor based on the higher value of similar types of cards for CPU load and memory. If the demux card's CPU utilization value is higher than the sessmgr card's CPU utilization value, then the demux card CPU utilization value is used for the load factor calculation.

Beginning with StarOS release 21, a new CLI command, **gtpc-system-param-poll interval**, is introduced in *Context Configuration Mode* to configure different polling intervals for the resource manager so that the demuxmgr can calculate the load factor based on different system requirements. This command sets the time period over which to monitor the chassis level CPU, Memory, and Session count information from the resource manager.

To configure the GTP-C polling parameter interval:

```

config
  context context_name
    gtpc-system-param-poll interval seconds
    default gtpc-system-param-poll interval
  end

```

- Where *seconds* is the time period over which to monitor the chassis level CPU, Memory, and Session count information from the resource manager. Valid entries are from 15 to 300 seconds. The default setting is 30 seconds.
- **default** returns the setting to its default value of 30 seconds.



Caution Setting the time interval to a low value may impact system performance.

Associating the 3GPP R12 Load Control Profile with a P-GW, SAEGW, or S-GW Service.

Once the 3GPP R12 GTP-C load control profile is created, it must be associated with an existing P-GW, SAEGW, or S-GW service.

Use the following examples to associate the GTP-C load control profile with an existing P-GW, SAEGW, or S-GW service.

P-GW Service Association:

```
configure
  context context_name
    pgw-service pgw_service_name
      associate gtpc-load-control-profile profile_name
      no associate gtpc-load-control-profile
    end
```

Notes:

- **no** disables the service association for the GTP-C Load Control Profile.

S-GW Service Association:

```
configure
  context context_name
    sgw-service sgw_service_name
      associate gtpc-load-control-profile profile_name
      no associate gtpc-load-control-profile
    end
```

Notes:

- **no** disables the service association for the GTP-C Load Control Profile.

SAEGW Service Association:

```
configure
  context context_name
    sgw-service sgw_service_name
      associate gtpc-load-control-profile profile_name
    exit
    pgw-service pgw_service_name
      associate gtpc-load-control-profile profile_name
    exit
    saegw-service saegw_service_name
      associate sgw-service sgw_service_name
      associate pgw-service pgw_service_name
    exit
```

Verifying the 3GPP R12 Load Control Configuration

Use the following command to view the load control profile configuration settings:

```
show gtpc-overload-control-profile full name load_control_profile_name
```

The output of this command provides the configuration settings of all load control parameters, including:

- Weightage
- Inclusion Frequency
- Load control information handling
- Load control information publishing
- Load threshold

Saving the Configuration

Save your configuration to flash memory, an external memory device, and/or a network location using the Exec mode command **save configuration**. For additional information on how to verify and save configuration files, refer to the *System Administration Guide* and the *Command Line Interface Reference*.

Creating and Configuring a 3GPP R12 GTP-C Overload Control Profile

This section describes how to create and configure a 3GPP R12 GTP-C overload control profile on the P-GW/SAEGW/S-GW.

Configuration Overview

-
- Step 1** Create the GTP-C overload control profile. Refer to [Creating the GTP-C Overload Control Profile](#), on page 490.
 - Step 2** Configure the weightage settings. Refer to [Configuring 3GPP R12 Overload Control Weightage Settings](#), on page 491.
 - Step 3** Configure the inclusion frequency. Refer to [Configuring the 3GPP R12 Overload Control Inclusion Frequency](#), on page 491.
 - Step 4** Configure the validity period. Refer to [Configuring the 3GPP R12 Overload Control Validity Period](#), on page 492.
 - Step 5** Configure the tolerance settings. Refer to [Configuring 3GPP R12 Overload Control Tolerance Limits](#), on page 492.
 - Step 6** Configure the throttling behavior for the node. Refer to [Configuring 3GPP R12 Overload Control Throttling Behavior](#), on page 493.
 - Step 7** Configure the message prioritization. Refer to [Configuring 3GPP R12 Overload Control Message Prioritization](#), on page 494.
 - Step 8** Configure self-protection behavior for the node. Refer to [Configuring 3GPP R12 Overload Control Self-Protection Behavior](#), on page 494.
 - Step 9** Configure overload control information handling. Refer to [Configuring 3GPP R12 Overload Control Information Handling](#), on page 495.
 - Step 10** Configure overload control information publishing. Refer to [Configuring 3GPP R12 Overload Control Information Publishing](#), on page 495.
 - Step 11** Configure the GTP-C polling parameter interval. Refer to [Configuring the 3GPP R12 GTP-C Polling Parameter Interval](#), on page 488.
 - Step 12** Associate the overload control configuration with an existing P-GW/SAEGW/S-GW service. Refer to [Associating the 3GPP R12 Overload Control Configuration with a P-GW, SAEGW, or S-GW Service](#), on page 496.
 - Step 13** Verify the overload control configuration. Refer to [Verifying the 3GPP R12 Overload Control Configuration](#), on page 497.
 - Step 14** Save the configuration. Refer to [Saving the 3GPP R12 Overload Control Configuration](#), on page 497.
-

Creating the GTP-C Overload Control Profile

Use the following example to create the GTP-C Overload Control Profile:

```

configure
  gtpc-overload-control-profile profile_name
  no gtpc-overload-control-profile profile_name
end

```

Notes:

- **no**: Removes specified GTP-C Overload Control profile.
- *profile_name* must be an alphanumeric string from 1 to 64 characters in length.

Configuring 3GPP R12 Overload Control Weightage Settings

This section describes how to configure GTP-C Overload Control weightage parameters. These parameters constitute the basic settings for this GTP-C Overload Control Profile. Communication of these parameters indicate to peers when this network element is becoming or being overloaded. When this occurs, the NE will be able to instruct its peers to gracefully reduce its incoming signaling load by instructing the peers to reduce sending traffic according to its available signaling capacity to successfully process the traffic. A GTP-C entity is in overload when it operates over its signaling capacity, which results in diminished performance (including impacts to handling of incoming and outgoing traffic).

Use the following example to configure the GTP-C Overload Control Weightage settings on the P-GW/SAEGW/S-GW.

```

configure
  gtpc-overload-control-profile profile_name
    weightage system-cpu-utilization percentage system-memory-utilization
    percentage license-session-utilization percentage.
  default weightage
end

```

Notes:

- Total weightage for all parameters should be 100.
- **system-cpu-utilization** *percentage*: Configures system cpu utilization weightage as a percentage of 100. *percentage* must be an integer from 0 to 100. The default is 40.
- **system-memory-utilization** *percentage*: Configures system memory utilization weightage as a percentage of 100. *percentage* must be an integer from 0 to 100. The default is 30.
- **license-session utilization** *percentage*: Configures license session utilization weightage as a percentage of 100. *percentage* must be an integer from 0 to 100. The default is 30.

Configuring the 3GPP R12 Overload Control Inclusion Frequency

This section describes how to set the parameters that determine the inclusion frequency of the Overload Control Information Element (OCI) for a GTP-C Load Control Profile configuration. The OCI is a 3GPP-specific IE that is sent to peers when a configured threshold is reached. This parameter specifies how often the operator wants to send this information to the peers.

Use the following example to configure the overload control profile inclusion frequency on the P-GW/SAEGW/S-GW.

```

configure
  gtpc-overload-control-profile profile_name

```

```

    inclusion-frequency { advertisement-interval interval_in_seconds |
change-factor change_factor }
    default inclusion-frequency { advertisement-interval | change-factor
}
end

```

Notes:

- **inclusion frequency:** Configures parameters to decide inclusion frequency of the OCI information element.
- **advertisement-interval *interval_in_seconds*:** Configures the advertisement-interval for overload control in seconds. Specifies how often overload control information should be sent to the peers. If configured to 0, the node will send overload control information in each and every outgoing message to the peers. *interval_in_seconds* must be an integer from 0 to 3600. The default is 300.
- **change-factor *change_factor*:** P-GW only. Configures the change factor for overload control. If the overload control factor changes by a configured factor, whether by an increase or decrease, the overload control information should be sent to the peers. This information is only sent to the peers when the overload factor changes by the factor configured. *change_factor* must be an integer from 1 to 20. The default is 5.

Configuring the 3GPP R12 Overload Control Validity Period

This section describes how to configure the overload control validity period. The validity period is the length of time during which the overload condition specified by the overload control information element is to be considered as valid, unless overridden by subsequent new overload control information.

Use the following example to configure the GTP-C Overload Control validity period on the P-GW/SAEGW/S-GW.

```

configure
  gtpc-overload-control-profile profile_name
    validity-period seconds
  default validity-period
end

```

Notes:

- **validity-period *seconds*:** Configures the validity of overload control information. *seconds* must be an integer from 1 to 3600. The default is 600 seconds.

Configuring 3GPP R12 Overload Control Tolerance Limits

Use this example to configure GTP-C Overload Control Tolerance limits.

```

configure
  gtpc-overload-control-profile profile_name
    tolerance { initial-reduction-metric percentage | threshold
report-reduction-metric percentage self-protection-limit percentage }
  default tolerance { initial-reduction-metric | threshold }
end

```

Notes:

- **initial-reduction-metric *percentage***: Configures initial overload reduction metric value to be advertised upon reaching minimum overload tolerance limit. When reaching the configured minimum threshold, this parameter specifies how much the node wants the peers to reduce incoming traffic. *percentage* must be an integer from 1 to 100. The default is 10.
- **threshold report-reduction-metric *percentage***: Configures the minimum overload tolerance threshold for advertising overload reduction metric to the peer. When the minimum threshold is reached, the node will report this information to peers. When the maximum limit is reached, the node will go into self-protection mode. *percentage* must be an integer from 1 to 100. The default is 80.
- The **threshold report-reduction-metric** should always be lower than the **self-protection-limit**.
- **self-protection-limit *percentage***: Configures the maximum overload tolerance threshold after which node will move to self protection mode. When the maximum limit is reached, the node will start rejecting all incoming messages, except for delete messages. The node will not initiate any new messages to the peers. This is to mitigate the overload condition. *percentage* must be an integer from 1 to 100. The default is 95.

Configuring 3GPP R12 Overload Control Throttling Behavior

Use this command to configure throttling behavior based on peer's overload reduction-metric by excluding some or all emergency events and/or messages with configured EARP. Message throttling applies only to initial messages. Triggered request or response messages should not be throttled since that would result in the retransmission of the corresponding request message by the sender.

If **throttling-behavior** is configured, the profile can be associated with an S-GW or P-GW service. If a P-GW specific keyword is configured, and the profile is associated with an S-GW service, the S-GW will ignore the P-GW specific configuration. Only the parameters specific to S-GW or P-GW will be utilized.

Use this example to configure GTP-C overload control throttling behavior on the P-GW/SAEGW/S-GW.

configure

```

gtpc-overload-control-profile profile_name
  throttling-behavior { earp [ 1 | 2 | 3 | 4 | 5 | 6 | 7 | 8 | 9 | 10
| 11 | 12 | 13 | 14 | 15 ]* exclude } | emergency-events exclude }
  no throttling-behavior [ earp [ 1 | 2 | 3 | 4 | 5 | 6 | 7 | 8 | 9 |
10 | 11 | 12 | 13 | 14 | 15 ]* exclude | emergency-events exclude ]
end

```

Notes:

- **throttling-behavior**: Configures throttling behavior based on peer's overload reduction-metric.
- **earp**: Excludes the specified messages with configured earp from throttling due to peer's overload-reduction metric. If a bearer with configured EARP is created or updated, it will be excluded from throttling.
- *****: Indicates that more than one of the keywords can be entered within a single command.
- **emergency-events exclude**: P-GW Only. Excludes all emergency events from throttling due to the peer's overload reduction-metric. While reducing messages towards the peer based on the overload information received from the peer, the P-GW will exclude events sent for emergency sessions.

Configuring 3GPP R12 Overload Control Message Prioritization

In the R12 GTP-C Load Overload control feature, it is possible to apply message throttling, (when a peer indicates it is overloaded), based on message priority. To apply message prioritization it is necessary to configure the percentage of two groups of messages that each node (P-GW or ePDG) is expected to generate. The operator can define the expected number of messages as a percentage for each message group.

Use the following example to configure message prioritization.

```
configure
  gtpc-overload-control-profile profile_name
    message-prioritization group1 percentage group2 percentage
    no message-prioritization
    default message-prioritization
  end
```

Notes:

- **group1** specifies the message priority percentage for the following messages:
 - Update Bearer Request message for default bearer generated from P-GW ingress
 - Update Bearer Request message for dedicated bearer generated from P-GW ingress
 - Handoff Create Session Request message generated from ePDG egress.
- **group2** specifies the message priority percentage for the following messages:
 - Create Bearer Request message for default bearer generated from P-GW ingress
 - PDN connection requested Create Session Request message from ePDG egress
- The total percentage for the message groups should equal 100.
- **group1** messages will have the highest priority (1) and are dropped last. **group2** messages will have the lowest priority (2) and are dropped first.
- **default** returns the group message priority settings to their default value. The default for each group is 50.
- The default behavior for this command is enabled. To disable the command use the **no** option.

Configuring 3GPP R12 Overload Control Self-Protection Behavior

This functionality enables the operator to configure APN names and EARP priority level values for self-protection mode so that incoming request messages for emergency packet data node (PDN) connections and/or configured EARP priority values are not rejected even if the system is under self-protection mode.

Use this example to configure GTP-C overload control self-protection behavior.

```
configure
  gtpc-overload-control-profile profile_name
    self-protection-behavior { apn apn_name* exclude | earp { 1 | 2 | 3
| 4 | 5 | 6 | 7 | 8 | 9 | 10 | 11 | 12 | 13 | 14 | 15* } exclude } }
    no self-protection-behavior { apn apn_name* exclude | earp { 1 | 2 |
3 | 4 | 5 | 6 | 7 | 8 | 9 | 10 | 11 | 12 | 13 | 14 | 15* } exclude } }
  end
```

Notes:

- **apn** configures up to three APN names to be allowed under self-protection behavior.

- **earp** configures up to three EARP priority level values so that incoming request messages for the configured evolved ARP priority values are not rejected even if the system is under self-protection mode.
- **no** disables the specified options.

Configuring 3GPP R12 Overload Control Information Handling

Use this command to enable/disable the handling of overload control information for the home or visited PLMN.

```
configure
  gtpc-load-control-profile profile_name
    overload-control-handling { home | visited }
  no overload-control-handling { home | visited }
  default overload-control-handling
end
```

Notes:

- **home**: Enables the handling of load control information for the home PLMN.
- **visited** enables the handling of load control information for the visited PLMN.
- **default**: Returns load control handling to its default behavior (enabled).

Configuring 3GPP R12 Overload Control Information Publishing

Enables or disables the publishing of load control information towards the home or visited PLMN.

```
configure
  gtpc-overload-control-profile profile_name
    overload-control-publishing { home | visited }
  no overload-control-publishing { home | visited }
  default overload-control-publishing
end
```

Notes:

- **home**: Enables the publishing of load control information towards the home PLMN.
- **visited**: Enables the publishing of load control information towards the visited PLMN.
- **default**: Returns load control handling to its default behavior (enabled).

Configuring the 3GPP R12 GTP-C Polling Parameter Interval

In capacity testing and also in customer deployments it was observed that the chassis load factor for the 3GPP R12 Load and Overload Support feature was providing incorrect values even when the sessmgr card CPU utilization was high. The root cause is that when the load factor was calculated by taking an average of CPU utilization of sessmgr and demux cards, the demux card CPU utilization never increased more than the sessmgr card CPU utilization. As a result, the system did not go into the overload state even when the sessmgr card CPU utilization was high.

The 3GPP R12 Load/Overload Control Profile feature has been enhanced to calculate the load factor based on the higher value of similar types of cards for CPU load and memory. If the demux card's CPU utilization value is higher than the sessmgr card's CPU utilization value, then the demux card CPU utilization value is used for the load factor calculation.

Beginning with StarOS release 21, a new CLI command, **gtpc-system-param-poll interval**, is introduced in *Context Configuration Mode* to configure different polling intervals for the resource manager so that the demuxmgr can calculate the load factor based on different system requirements. This command sets the time period over which to monitor the chassis level CPU, Memory, and Session count information from the resource manager.

To configure the GTP-C polling parameter interval:

```
config
context context_name
  gtpc-system-param-poll interval seconds
  default gtpc-system-param-poll interval
end
```

- Where *seconds* is the time period over which to monitor the chassis level CPU, Memory, and Session count information from the resource manager. Valid entries are from 15 to 300 seconds. The default setting is 30 seconds.
- **default** returns the setting to its default value of 30 seconds.



Caution Setting the time interval to a low value may impact system performance.

Associating the 3GPP R12 Overload Control Configuration with a P-GW, SAEGW, or S-GW Service

Once the 3GPP R12 overload control profile has been configured, it must be associated with an existing P-GW, SAEGW, or S-GW service.

Use the following examples to associate the overload control configuration to an existing service.

P-GW Service Association:

```
configure
context context_name
  pgw-service pgw_service_name
  associate gtpc-overload-control-profile profile_name
  no associate gtpc-overload-control-profile
end
```

Notes:

- **no** disables the service association for the GTP-C Load Control Profile.

S-GW Service Association:

```
configure
context context_name
  sgw-service sgw_service_name
  associate gtpc-overload-control-profile profile_name
  no associate gtpc-overload-control-profile
end
```

Notes:

- **no** disables the service association for the GTP-C Load Control Profile.

SAEGW Service Association:

```

configure
context context_name
  sgw-service sgw_service_name
    associate gtpc-overload-control-profile profile_name
  exit
  pgw-service pgw_service_name
    associate gtpc-overload-control-profile profile_name
  exit
  saegw-service saegw_service_name
    associate sgw-service sgw_service_name
    associate pgw-service pgw_service_name
  exit

```

Verifying the 3GPP R12 Overload Control Configuration

Use the following command to view the overload control configuration settings.

```
show gtpc-overload-control-profile full name overload_control_profile_name
```

The output of this command provides all overload control profile configuration settings, including:

- Weightage
- Tolerance
- Inclusion Frequency
- Validity Period
- Throttling Profile
- Self-Protection Behavior
- Overload control information Handling
- Overload control information Publishing
- Message Prioritization

Saving the 3GPP R12 Overload Control Configuration

Save your configuration to flash memory, an external memory device, and/or a network location using the Exec mode command **save configuration**. For additional information on how to verify and save configuration files, refer to the *System Administration Guide* and the *Command Line Interface Reference*.

Monitoring and Troubleshooting the 3GPP R12 GTP-C Load and Overload Control Feature

This section provides information to assist operators in monitoring the 3GPP R12 GTP-C Load and Overload Control feature.

3GPP R12 GTP-C Load and Overload Show Commands

This section provides information regarding show commands in support of the 3GPP R12 Load and Overload Control feature.

show egtpc statistics egtp-service <egtp-service name>

The output of this command provides detailed granular statistics for 3GPP R12 load and overload control profile statistics that have been transmitted (TX) and received (RX). Statistics are provided on a per egtp-service basis.

show gtpc-load-control-profile full all

The output of this command provides all configuration settings for all 3GPP R12 load control profiles configured on the node. Use this command to determine if the load control profile is configured as intended.

show gtpc-load-control-profile full name <name>

Use this command to view all configuration settings for the specified 3GPP R12 load control profile.

show gtpc-overload-control-profile full all

The output of this command provides all configuration settings for all 3GPP R12 overload control profiles configured on the node. Use this command to determine if the overload control profile is configured as intended.

show gtpc-overload-control full name <name>

The output of this command provides all configuration settings for all 3GPP R12 Overload Control Profiles configured on the node. Use this command to determine if the Overload Control Profile is configured as intended.

show pgw-service all

Use this command to obtain the names of all 3GPP R12 load control and 3GPP R12 overload control profiles configured on the P-GW.

show sgw-service all

Use this command to obtain the names of all 3GPP R12 Load Control and Overload Control profiles configured on the S-GW.

eGTP-C Bulk Statistics

The following statistics are included in the eGTP-C Schema in support of the 3GPP R12 Load and Overload Control feature:

- load-overload-own-lci
- load-overload-own-oci
- load-overload-num-msg-throttled
- load-overload-num-ovrload-cond-reached

For descriptions of these variables, see "eGTP Schema Statistics" in the *Statistics and Counters Reference*.



CHAPTER 23

Gx Interface Support

This chapter provides information on configuring Gx interface to support policy and charging control for subscribers.

The IMS service provides application support for transport of voice, video, and data independent of access support. Roaming IMS subscribers require apart from other functionality sufficient, uninterrupted, consistent, and seamless user experience during an application session. It is also important that a subscriber gets charged only for the resources consumed by the particular IMS application used.

It is recommended that before using the procedures in this chapter you select the configuration example that best meets your service model, and configure the required elements for that model as described in this Administration Guide.

The following topics are covered in this chapter:

- [Rel. 7 Gx Interface, on page 499](#)
- [Rel. 8 Gx Interface, on page 524](#)
- [Rel. 9 Gx Interface, on page 545](#)
- [Rel. 10 Gx Interface, on page 553](#)
- [Supported Gx Features, on page 560](#)

Rel. 7 Gx Interface

Rel. 7 Gx interface support is available on the Cisco ASR chassis for the following products:

- GGSN
- IPSP

This section describes the following topics:

- [Introduction, on page 500](#)
- [Terminology and Definitions, on page 502](#)
- [How Rel. 7 Gx Works, on page 516](#)
- [Configuring Rel. 7 Gx Interface, on page 519](#)
- [Gathering Statistics, on page 523](#)

Introduction

For IMS deployment in GPRS/UMTS networks the system uses Rel. 7 Gx interface for policy-based admission control support and flow-based charging. The Rel. 7 Gx interface supports enforcing policy control features like gating, bandwidth limiting, and so on, and also supports flow-based charging. This is accomplished via dynamically provisioned Policy Control and Charging (PCC) rules. These PCC rules are used to identify Service Data Flows (SDF) and do charging. Other parameters associated with the rules are used to enforce policy control.

The PCC architecture allows operators to perform service-based QoS policy, and flow-based charging control. In the PCC architecture, this is accomplished mainly by the Policy and Charging Enforcement Function (PCEF)/Cisco Systems GGSN and the Policy and Charging Rules Function (PCRF).

In GPRS/UMTS networks, the client functionality lies with the GGSN, therefore in the IMS authorization scenario it is also called the Gateway. In the following figure, Gateway is the Cisco Systems GGSN, and the PCEF function is provided by Enhanced Charging Service (ECS). The Rel 7. Gx interface is implemented as a Diameter connection. The Gx messages mostly involve installing/modifying/removing dynamic rules and activating/deactivating predefined rules.

The Rel. 7 Gx reference point is located between the Gateway and the PCRF. This reference point is used for provisioning and removal of PCC rules from the PCRF to the Gateway, and the transmission of traffic plane events from the Gateway to the PCRF. The Gx reference point can be used for charging control, policy control, or both by applying AVPs relevant to the application. The following figure shows the reference points between various elements involved in the policy and charging architecture.

Figure 95: PCC Logical Architecture

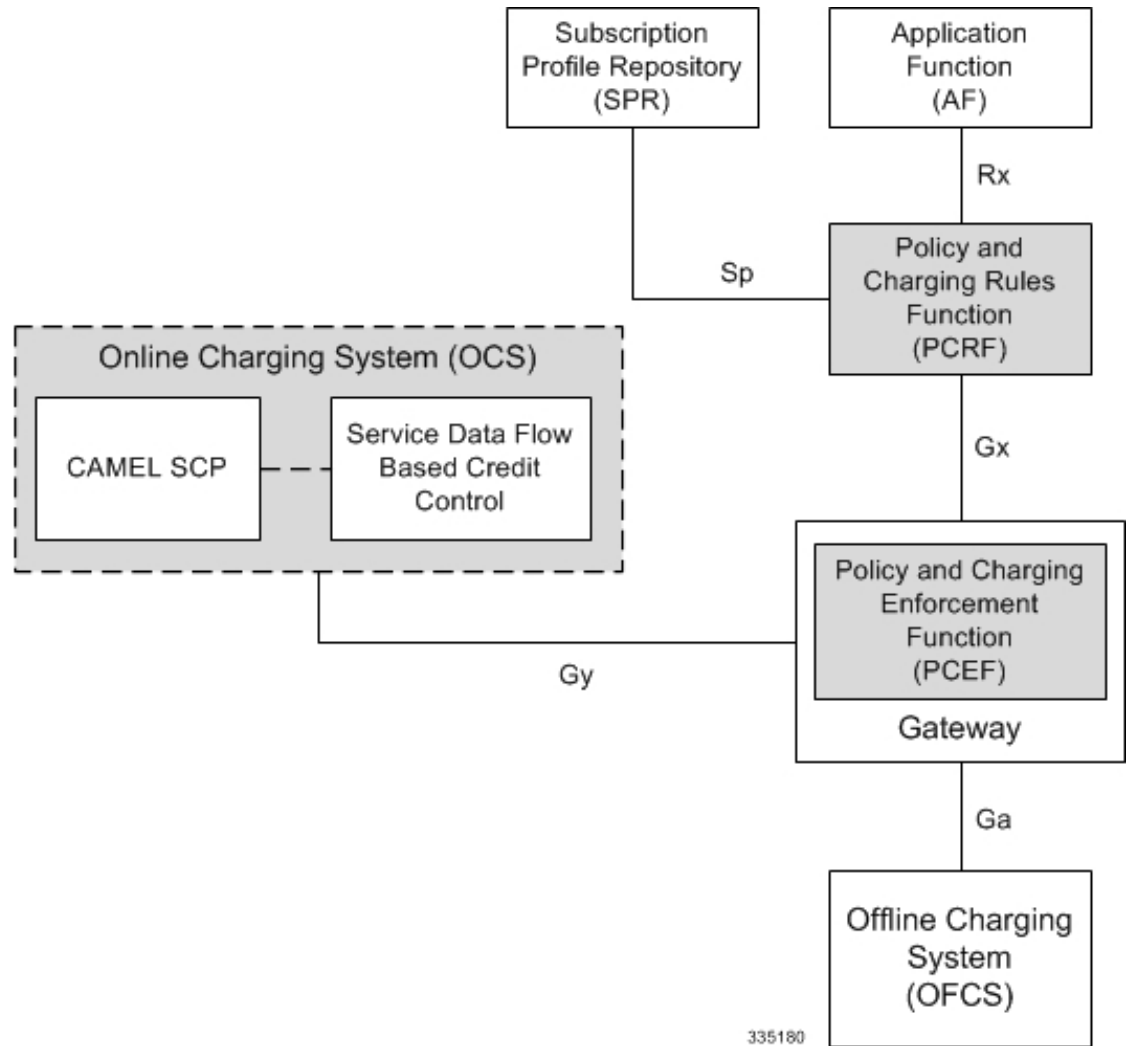

Within the Gateway, the IMSA and DPCA modules handle the Gx protocol related functions (at the SessMgr) and the policy enforcement and charging happens at ECS. The Gy protocol related functions are handled within the DCCA module (at the ECS). The following figure shows the interaction between components within the Gateway.

Figure 96: PCC Architecture within Cisco PCEF

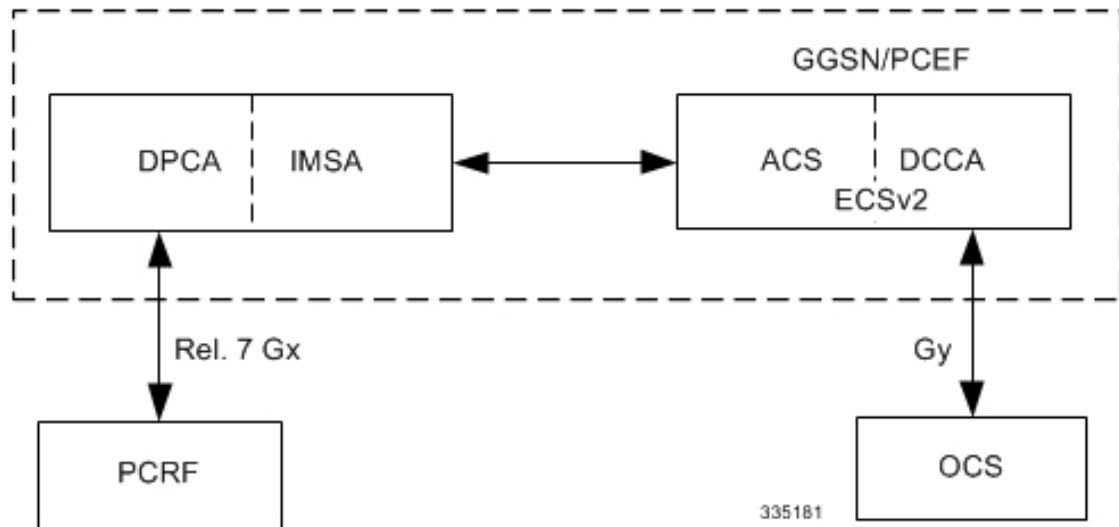

Supported Networks and Platforms

This feature is supported on all chassis running GGSN service for the core network services.

License Requirements

The Rel. 7 Gx interface support is a licensed Cisco feature. A separate feature license may be required. Contact your Cisco account representative for detailed information on specific licensing requirements. For information on installing and verifying licenses, refer to the *Managing License Keys* section of the *Software Management Operations* chapter in the *System Administration Guide*.

Supported Standards

The Rel 7. Gx interface support is based on the following standards and RFCs:

- 3GPP TS 23.203 V7.6.0 (2008-03): 3rd Generation Partnership Project; Technical Specification Group Services and System Aspects; Policy and charging control architecture (Release 7)
- 3GPP TS 29.212 V7.8.0 (2009-03): 3rd Generation Partnership Project; Technical Specification Group Core Network and Terminals; Policy and Charging Control over Gx reference point (Release 7)
- 3GPP TS 29.213 V7.4.0 (2008-03): 3rd Generation Partnership Project; Technical Specification Group Core Network and Terminals; Policy and Charging Control signalling flows and QoS parameter mapping; (Release 7)
- RFC 3588, Diameter Base Protocol; September 2003
- RFC 4006, Diameter Credit-Control Application; August 2005

Terminology and Definitions

This section describes features and terminology pertaining to Rel. 7 Gx functionality.

Policy Control

The process whereby the PCRF indicates to the PCEF how to control the IP-CAN bearer.

Policy control comprises the following functions:

- **Binding:** Binding is the generation of an association between a Service Data Flow (SDF) and the IP-CAN bearer (for GPRS a PDP context) transporting that SDF.

The QoS demand in the PCC rule, as well as the SDF template are input for the bearer binding. The selected bearer will have the same QoS Class as the one indicated by the PCC rule.

Depending on the type of IP-CAN and bearer control mode, bearer binding can be executed either by the PCRF, or both PCRF and PCEF.

- For UE-only IP-CAN bearer establishment mode, the PCRF performs bearer binding. When the PCRF performs bearer binding, it indicates the bearer (PDP context) by means of Bearer ID. The Bearer ID uniquely identifies the bearer within the PDP session.
- For UE/NW IP-CAN bearer establishment mode, the PCRF performs the binding of the PCC rules for user controlled services, while the PCEF performs the binding of the PCC rules for the network-controlled services.

The binding of PCEF rules will be successful when BCM mode is set to UE-only for EPS IP-CAN bearer without "bearer-ID" in the PCRF messages such as RAR or CCA-U.

In the 3G to 4G handover scenario, rule binding and rule removal will be successful in UE-only mode and any filter (and related info) changes because of this modification/installation/removal will not be notified to UE as updates in UE only mode cannot be sent to UE. These rules are only considered for charging and the expectation is that the same rules are again modified in 4G (if handover is done) so that the filters (and related info) can be notified to UE.

The CCR-U is generated and sent to PCRF for reporting rule failure when the collision happens during GnGp HO scenario.

This additional Gx message (CCR-U) triggered will require multiple CCR-U's to be configured when RAT_TYPE trigger is enabled. Otherwise, the subscriber call will be dropped whenever the collision happens during HO.

- **Gating Control:** Gating control is the blocking or allowing of packets, belonging to an SDF, to pass through to the desired endpoint. A gate is described within a PCC rule and gating control is applied on a per SDF basis. The commands to open or close the gate leads to the enabling or disabling of the passage for corresponding IP packets. If the gate is closed, all packets of the related IP flows are dropped. If the gate is opened, the packets of the related IP flows are allowed to be forwarded.
- **Event Reporting:** Event reporting is the notification of and reaction to application events to trigger new behavior in the user plane as well as the reporting of events related to the resources in the Gateway (PCEF).
 - Event triggers may be used to determine which IP-CAN session modification or specific event causes the PCEF to re-request PCC rules. Although event trigger reporting from PCEF to PCRF can apply for an IP-CAN session or bearer depending on the particular event, provisioning of event triggers will be done at session level.

The RAR with unknown event triggers are silently ignored and responded with DIAMETER_SUCCESS.

- The Event Reporting Function (ERF) receives event triggers from PCRF during the Provision of PCC Rules procedure and performs event trigger detection. When an event matching the received event trigger occurs, the ERF reports the occurred event to the PCRF. If the provided event triggers are associated with certain parameter values then the ERF includes those values in the response back to the PCRF. The Event Reporting Function is located in the PCEF.

SUCCESSFUL_RESOURCE_ALLOCATION (22) event trigger will be sent under the following conditions:

- When a rule is installed successfully (and the event trigger is armed by PCRF and resource-allocation-notification is enabled).
- On partial failure, i.e., when two or more rules are installed and at least one of the rules were successfully installed. (and the event trigger is armed by PCRF and resource-allocation-notification is enabled).

On complete failure, i.e., none of the rules were installed, the event-trigger SUCCESSFUL_RESOURCE_ALLOCATION (22) will not be sent.



Important In this release, event triggers "IP-CAN_CHANGE" and "MAX_NR_BEARERS_REACHED" are not supported.

- **QoS Control:** QoS control is the authorization and enforcement of the maximum QoS that is authorized for a SDF or an IP-CAN bearer or a QoS Class Identifier (QCI). In case of an aggregation of multiple SDFs (for GPRS a PDP context), the combination of the authorized QoS information of the individual SDFs is provided as the authorized QoS for this aggregate.
 - QoS control per SDF allows the PCC architecture to provide the PCEF with the authorized QoS to be enforced for each specific SDF.
 - The enforcement of the authorized QoS of the IP-CAN bearer may lead to a downgrading or upgrading of the requested bearer QoS by the Gateway (PCEF) as part of a UE-initiated IP-CAN bearer establishment or modification. Alternatively, the enforcement of the authorized QoS may, depending on operator policy and network capabilities, lead to network-initiated IP-CAN bearer establishment or modification. If the PCRF provides authorized QoS for both, the IP-CAN bearer and PCC rule(s), the enforcement of authorized QoS of the individual PCC rules takes place first.
 - QoS authorization information may be dynamically provisioned by the PCRF, or it can be a predefined PCC rule in the PCEF. In case the PCRF provides PCC rules dynamically, authorized QoS information for the IP-CAN bearer (combined QoS) may be provided. For a predefined PCC rule within the PCEF, the authorized QoS information takes affect when the PCC rule is activated. The PCEF combines the different sets of authorized QoS information, that is the information received from the PCRF and the information corresponding to the predefined PCC rules. The PCRF knows the authorized QoS information of the predefined PCC rules and takes this information into account when activating them. This ensures that the combined authorized QoS of a set of PCC rules that are activated by the PCRF is within the limitations given by the subscription and operator policies regardless of whether these PCC rules are dynamically provided, predefined, or both.



Important In this release, QoS Resource Reservation is not supported.

Supported Features:

- Provisioning and Policy Enforcement of Authorized QoS: The PCRF may provide authorized QoS to the PCEF. The authorized QoS provides appropriate values for resources to be enforced.
- Provisioning of "Authorized QoS" Per IP CAN Bearer: The authorized QoS per IP-CAN bearer is used if the bearer binding is performed by the PCRF.
- Policy Enforcement for "Authorized QoS" per IP CAN Bearer: The PCEF is responsible for enforcing the policy-based authorization, that is to ensure that the requested QoS is in-line with the "Authorized QoS" per IP CAN Bearer.
- Policy Provisioning for Authorized QoS Per SDF: The provisioning of authorized QoS per SDF is a part of PCC rule provisioning procedure.
 - Policy Enforcement for Authorized QoS Per SDF: If an authorized QoS is defined for a PCC rule, the PCEF limits the data rate of the SDF corresponding to that PCC rule not to exceed the maximum authorized bandwidth for the PCC rule by discarding packets exceeding the limit.
 - Upon deactivation or removal of a PCC rule, the PCEF frees the resources reserved for that PCC rule. If the PCRF provides authorized QoS for both the IP-CAN bearer and PCC rule(s), the enforcement of authorized QoS of the individual PCC rules takes place first.



Important In this release, coordination of authorized QoS scopes in mixed mode (BCM = UE_NW) is not supported.

- Provisioning of Authorized QoS Per QCI: If the PCEF performs the bearer binding, the PCRF may provision an authorized QoS per QCI for non-GBR bearer QCI values. If the PCRF performs the bearer binding the PCRF does not provision an authorized QoS per QCI. The PCRF does not provision an authorized QoS per QCI for GBR bearer QCI values.



Important Only standards-based QCI values of 1 through 9 are supported. QCI values 1 through 9 are defined in 3GPP Specification TS 23.203 "Policy and charging control architecture".

- Policy Enforcement for Authorized QoS per QCI: The PCEF can receive an authorized QoS per QCI for non GBR-bearer QCI values.
- Other Features:
 - Bearer Control Mode Selection: The PCEF may indicate, via the Gx reference point, a request for Bearer Control Mode (BCM) selection at IP-CAN session establishment or IP-CAN session modification (as a consequence of an SGSN change). It will be done using the "PCC Rule Request" procedure.

If the Bearer-Control-Mode AVP is not received from PCRF, the IP-CAN session is not terminated. The value negotiated between UE/SGSN/GGSN is considered as the BCM. The following values are considered for each of the service types:

- GGSN: The negotiated value between UE/SGSN/GGSN is considered.

In the following scenarios UE_ONLY is chosen as the BCM:

Scenario 1:

- UE-> UE_ONLY
- SGSN-> UE_ONLY
- GGSN-> UE_ONLY
- PCRF-> NO BCM

Scenario 2:

- UE-> UE_ONLY
 - SGSN-> UE_ONLY
 - GGSN-> Mixed
 - PCRF-> NO BCM
- GTP-PGW: BCM of UE_NW is considered.
 - IPSG: BCM of UE_ONLY is considered.
 - HSGW/SGW/PDIF/FA/PDSN/HA/MIPV6HA: BCM of NONE is considered.
- PCC Rule Error Handling: If the installation/activation of one or more PCC rules fails, the PCEF includes one or more Charging-Rule-Report AVP(s) in either a CCR or an RAA command for the affected PCC rules. Within each Charging-Rule-Report AVP, the PCEF identifies the failed PCC rule(s) by including the Charging-Rule-Name AVP(s) or Charging-Rule-Base-Name AVP(s), identifies the failed reason code by including a Rule-Failure-Code AVP, and includes the PCC-Rule-Status AVP.
- If the installation/activation of one or more new PCC rules (that is, rules that were not previously successfully installed) fails, the PCEF sets the PCC-Rule-Status to INACTIVE for both the PUSH and the PULL modes.
- If a PCC rule was successfully installed/activated, but can no longer be enforced by the PCEF, the PCEF sends the PCRF a new CCR command and include a Charging-Rule-Report AVP. The PCEF includes the Rule-Failure-Code AVP within the Charging-Rule-Report AVP and sets the PCC-Rule-Status to INACTIVE.
- The CCR-U is generated and sent to PCRF for reporting rule failure when the collision happens during GnGp HO scenario.
- This additional Gx message (CCR-U) triggered will require multiple CCR-Us to be configured when RAT_TYPE trigger is enabled. Otherwise, the subscriber call will be dropped whenever the collision happens during HO.
- Time of the Day Procedures: PCEF performs PCC rule request as instructed by the PCRF. Revalidation-Time when set by the PCRF, causes the PCEF to trigger a PCRF interaction to request PCC rules from the PCRF for an established IP CAN session. The PCEF stops the timer once the PCEF triggers a REVALIDATION_TIMEOUT event.



Important Rule-Activation-Time / Rule-Deactivation-Time / Revalidation-Time AVP is successfully parsed only if its value corresponds to current time or a later time than the current IPSG time, else the AVP and entire message is rejected.

If Rule-Deactivation-Time AVP is omitted in CCA/RAR, then any previous value for this AVP is no longer valid. The new behavior is compliant to the 3GPP specification for Gx, version 12.1.0.

If PCRF enables the same predefined rule again in RAR/CCA-U without Rule-Deactivation-Time AVP, then the deactivation-time for this rule, if any, will be removed.

For switching to the old behavior, PCRF should re-send the same value of Rule-Deactivation-Time AVP along with predef-rule name in the PCRF message (RAR, CCA-U).



Important This behavior change is applicable only to predefined rules.

Support for Firewall Policy on Gx: The Diameter AVP "SN-Firewall-Policy" has been added to the Diameter dynamic dictionary to support Firewall policy on Gx interface. This AVP can be encoded in CCA-I message to apply/overwrite the fw-and-nat policy that has either been statically assigned to the PDP context via APN configuration or dynamically assigned via RADIUS in Access-Accept. This AVP can also be parsed in any CCA-U or RAR message to modify the fw-and-nat policy that is currently assigned to the PDP context.

Charging Control

Charging Control is the process of associating packets belonging to a SDF to a charging key, and applying online charging and/or offline charging, as appropriate. Flow-based charging handles differentiated charging of the bearer usage based on real time analysis of the SDFs. In order to allow for charging control, the information in the PCC rule identifies the SDF and specifies the parameters for charging control. The PCC rule information may depend on subscription data.

In the case of online charging, it is possible to apply an online charging action upon PCEF events (for example, re-authorization upon QoS change).

It is possible to indicate to the PCEF that interactions with the charging systems are not required for a PCC rule, that is to perform neither accounting nor credit control for this SDF, and then no offline charging information is generated.

Supported Features:

- Provisioning of Charging-related Information for the IP-CAN Session.
- Provisioning of Charging Addresses: Primary or secondary event charging function name (Online Charging Server (OCS) addresses or the peer names).



Important In this release, provisioning of primary or secondary charging collection function name (Offline Charging Server (OFCS) addresses) over Gx is not supported.

- Provisioning of Default Charging Method: In this release, the default charging method is sent in CCR-I message. For this, new AVPs Online/Offline are sent in CCR-I message based on the configuration. The

Online/Offline AVP received at command level applies only to dynamic rules if they are not configured at PCC rule level.

Charging Correlation

For the purpose of charging correlation between SDF level and application level (for example, IMS) as well as on-line charging support at the application level, applicable charging identifiers and IP-CAN type identifiers are passed from the PCRF to the AF, if such identifiers are available.

For IMS bearer charging, the IP Multimedia Core Network (IM CN) subsystem and the Packet Switched (PS) domain entities are required to generate correlated charging data.

In order to achieve this, the Gateway provides the GGSN Charging Identifier (GCID) associated with the PDP context along with its address to the PCRF. The PCRF in turn sends the IMS Charging Identifier (ICID), which is provided by the P-CSCF, to the Gateway. The Gateway generates the charging records including the GCID as well as the ICID if received from PCRF, so that the correlation of charging data can be done with the billing system.

PCRF also provides the flow identifier, which uniquely identifies an IP flow in an IMS session.

Policy and Charging Control (PCC) Rules

A PCC rule enables the detection of an SDF and provides parameters for policy control and/or charging control. The purpose of the PCC rule is to:

- Detect a packet belonging to an SDF.
 - Select downlink IP CAN bearers based on SDF filters in the PCC rule.
 - Enforce uplink IP flows are transported in the correct IP CAN bearer using the SDF filters within the PCC rule.
- Identify the service that the SDF contributes to.
- Provide applicable charging parameters for an SDF.
- Provide policy control for an SDF.

The PCEF selects a PCC rule for each packet received by evaluating received packets against SDF filters of PCC rules in the order of precedence of the PCC rules. When a packet matches a SDF filter, the packet matching process for that packet is completed, and the PCC rule for that filter is applied.

There are two types of PCC rules:

- **Dynamic PCC Rules:** Rules dynamically provisioned by the PCRF to the PCEF via the Gx interface. These PCC rules may be either predefined or dynamically generated in the PCRF. Dynamic PCC rules can be installed, modified, and removed at any time.
- **Predefined PCC Rule:** Rules preconfigured in the PCEF by the operators. Predefined PCC rules can be activated or deactivated by the PCRF at any time. Predefined PCC rules within the PCEF may be grouped allowing the PCRF to dynamically activate a set of PCC rules over the Gx reference point.



Important A third type of rule, the static PCC rule can be preconfigured in the chassis by the operators. Static PCC rules are not explicitly known in the PCRF, and are not under control of the PCRF. Static PCC rules are bound to general purpose bearer with no Gx control.

A PCC rule consists of:

- **Rule Name:** The rule name is used to reference a PCC rule in the communication between the PCEF and PCRF.
- **Service Identifier:** The service identifier is used to identify the service or the service component the SDF relates to.
- **Service Data Flow Filter(s):** The service flow filter(s) is used to select the traffic for which the rule applies.
- **Precedence:** For different PCC rules with overlapping SDF filter, the precedence of the rule determines which of these rules is applicable. When a dynamic PCC rule and a predefined PCC rule have the same priority, the dynamic PCC rule takes precedence.
- **Gate Status:** The gate status indicates whether the SDF, detected by the SDF filter(s), may pass (gate is open) or will be discarded (gate is closed) in uplink and/or in downlink direction.
- **QoS Parameters:** The QoS information includes the QoS class identifier (authorized QoS class for the SDF), the Allocation and Retention Priority (ARP), and authorized bitrates for uplink and downlink.



Important ECS uses the entire ARP byte for bearer binding (along with QCI). Since the capability and vulnerability bits are optional in a dynamic rule, if a dynamic rule is received without these flags, it is assumed that the capability bit is set to 1 (disabled) and vulnerability bit is set to 0 (enabled). For predefined rules, these two flags is not supported, so as of now all predefined rules are assumed to have capability bit set to 1 (disabled) and vulnerability bit set to 0 (enabled).

- **Charging key (rating group)**
- **Other charging parameters:** The charging parameters define whether online and offline charging interfaces are used, what is to be metered in offline charging, on what level the PCEF will report the usage related to the rule, and so on.



Important In this release, configuring the Metering Method and Reporting Level for dynamic PCC rules is not supported.

PCC rules also include Application Function (AF) record information for enabling charging correlation between the application and bearer layer if the AF has provided this information via the Rx interface. For IMS, this includes the IMS Charging Identifier (ICID) and flow identifiers.



Important ASR 5500 supports only eight flow information including the flow description per dynamic charging rule in a Gx message.

There are 24 PCC rules that can be recovered per bearer in the event of a session manager crash. Also, up to 24 PCC rules can be recovered post ICSR.

When modification for the PCC rules in pending-active state is received, the modified parameters will be buffered at P-GW. After the response for the pending request is received from the access network, P-GW will process the modification of the buffered parameters and if required generate another update towards network.

PCC Procedures over Gx Reference Point

Request for PCC Rules

The PCEF, via the Gx reference point, requests for PCC rules in the following instances:

- At IP-CAN session establishment
- At IP-CAN session modification

PCC rules can also be requested as a consequence of a failure in the PCC rule installation/activation or enforcement without requiring an event trigger.

Provisioning of PCC Rules

The PCRF indicates, via the Rel. 8 Gx reference point, the PCC rules to be applied at the PCEF. This may be using one of the following procedures:

- PULL (provisioning solicited by the PCEF): In response to a request for PCC rules being made by the PCEF, the PCRF provisions PCC rules in the CC-Answer.
- PUSH (unsolicited provisioning): The PCRF may decide to provision PCC rules without obtaining a request from the PCEF. For example, in response to information provided to the PCRF via the Rx reference point, or in response to an internal trigger within the PCRF. To provision PCC rules without a request from the PCEF, the PCRF includes these PCC rules in an RA-Request message. No CCR/CCA messages are triggered by this RA-Request.

For each request from the PCEF or upon unsolicited provisioning, the PCRF provisions zero or more PCC rules. The PCRF may perform an operation on a single PCC rule by one of the following means:

- To activate or deactivate a PCC rule that is predefined at the PCEF, the PCRF provisions a reference to this PCC rule within a Charging-Rule-Name AVP and indicates the required action by choosing either the Charging-Rule-Install AVP or the Charging-Rule-Remove AVP.
- To install or modify a PCRF-provisioned PCC rule, the PCRF provisions a corresponding Charging-Rule-Definition AVP within a Charging-Rule-Install AVP.
- To remove a PCC rule which has previously been provisioned by the PCRF, the PCRF provisions the name of this rule as value of a Charging-Rule-Name AVP within a Charging-Rule-Remove AVP.



Important

The maximum valid length for a charging rule name is 63 bytes. When the length of the charging rule name is greater than 63 bytes, a charging rule report with RESOURCES_LIMITATION as Rule-Failure-Code is sent. This charging rule report is sent only when the length of the rule name is lesser than 128 characters. When the charging rule name length is greater than or equal to 128 characters no charging rule report will be sent.

During session connect, P-GW combines the rule failure and out of credit in the same CCR-U and sends to PCRF.

Selecting a PCC Rule for Uplink IP Packets

If PCC is enabled, the PCEF selects the applicable PCC rule for each received uplink IP packet within an IP CAN bearer by evaluating the packet against uplink SDF filters of PCRF-provided or predefined active PCC rules of this IP CAN bearer in the order of the precedence of the PCC rules.



Important When a PCRF-provided PCC rule and a predefined PCC rule have the same precedence, the uplink SDF filters of the PCRF-provided PCC rule is applied first.



Important IMSA and ECS allow the PCRF to install two (or more) dynamic rules with the same precedence value.

When a packet matches an SDF filter, the packet matching process for that packet is completed, and the PCC rule for that filter is applied. Uplink IP packets which do not match any PCC rule of the corresponding IP CAN bearer are discarded.

Selecting a PCC Rule and IP CAN Bearer for Downlink IP Packets

If PCC is enabled, the PCEF selects a PCC rule for each received downlink IP packet within an IP CAN session by evaluating the packet against downlink SDF filters of PCRF-provided or predefined active PCC rules of all IP CAN bearers of the IP CAN session in the order of the precedence of the PCC rules.



Important When a PCRF-provided PCC rule and a predefined PCC rule have the same precedence, the downlink SDF filters of the PCRF-provided PCC rule are applied first.

When a packet matches a SDF filter, the packet matching process for that packet is completed, and the PCC rule for that filter is applied. The Downlink IP Packet is transported within the IP CAN bearer where the selected PCC rule is mapped. Downlink IP packets that do not match any PCC rule of the IP CAN session are discarded.

The following procedures are also supported:

- Indication of IP-CAN Bearer Termination Implications
- Indication of IP-CAN Session Termination: When the IP-CAN session is being terminated (for example, for GPRS when the last PDP Context within the IP-CAN session is being terminated) the PCEF contacts the PCRF.
- Request of IP-CAN Bearer Termination: If the termination of the last IP CAN bearer within an IP CAN session is requested, the PCRF and PCEF apply the "Request of IP-CAN Session Termination" procedure.
- Request of IP-CAN Session Termination: If the PCRF decides to terminate an IP CAN session due to an internal trigger or trigger from the SPR, the PCRF informs the PCEF. The PCEF acknowledges to the PCRF and instantly removes/deactivates all the PCC rules that have been previously installed or activated on that IP-CAN session.

The PCEF applies IP CAN specific procedures to terminate the IP CAN session. For GPRS, the GGSN send a PDP context deactivation request with the teardown indicator set to indicate that the termination of the entire IP-CAN session is requested. Furthermore, the PCEF applies the "Indication of IP CAN Session Termination" procedure.

Volume or rule information obtained from PCRF is discarded if the subscriber is going down.

Volume Reporting Over Gx

This section describes the 3GPP Rel. 9 Volume Reporting over Gx feature, which is supported by all products supporting Rel. 7 Gx interface.

License Requirements

The Volume Reporting over Gx is a licensed Cisco feature. A separate feature license may be required. Contact your Cisco account representative for detailed information on specific licensing requirements. For information on installing and verifying licenses, refer to the *Managing License Keys* section of the *Software Management Operations* chapter in the *System Administration Guide*.



Important No separate license is required for Charging over Gx / Volume Reporting over Gx feature. This feature can be enabled as part of "Policy Interface" license.

Supported Standards

The Volume Reporting over Gx feature is based on the following standard:

3GPP TS 29.212 V9.5.0 (2010-06): 3rd Generation Partnership Project; Technical Specification Group Core Network and Terminals; Policy and Charging Control over Gx reference point (Release 9).

Feature Overview

The Volume Reporting over Gx feature provides PCRF the capability to make real-time decisions based on the data usage by subscribers.



Important Volume Reporting over Gx is applicable only for volume quota.

The PCEF only reports the accumulated usage since the last report for usage monitoring and not from the beginning.

If the usage threshold is set to zero (infinite threshold), no further threshold events will be generated by PCEF, but monitoring of usage will continue and be reported at the end of the session.

The usage reporting on bearer termination and uplink/downlink level reporting are supported.

The following steps explain how Volume Reporting over Gx works:

1. PCEF after receiving the message from PCRF parses the usage monitoring related AVPs, and sends the information to IMSA.
2. IMSA updates the information to ECS.
3. Once the ECS is updated with the usage monitoring information from PCRF, the PCEF (ECS) starts tracking the data usage.

4. For session-level monitoring, the ECS maintains the amount of data usage.
5. For PCC rule monitoring, usage is monitored with the monitoring key as the unique identifier. Each node maintains the usage information per monitoring key. When the data traffic is passed, the usage is checked against the usage threshold values and reported as described in the *Usage Reporting* section.
6. The PCEF continues to track data usage after the threshold is reached and before a new threshold is provided by the PCRF. If a new usage threshold is not provided by the PCRF in the acknowledgement of an IP-CAN Session modification where its usage was reported, then usage monitoring does not continue in the PCEF for that IP CAN session.

Usage Monitoring

- Usage Monitoring at Session Level: PCRF subscribes to the session-level volume reporting over Gx by sending the Usage-Monitoring-Information AVP with the usage threshold level set in Granted-Service-Unit AVP and Usage-Monitoring-Level AVP set to SESSION_LEVEL(0). After the AVPs are parsed by DPCA, IMSA updates the information to ECS. Once ECS is updated usage monitoring is started and constantly checked with the usage threshold whenever the data traffic is present. Monitoring key at session level is supported.

Enabling and disabling session usage in a single message from PCRF is supported. This is supported only if the monitoring key is associated at session level.

Monitoring of usage based on input/output octet threshold levels is supported. Usage is reported based on the enabled threshold level. If multiple levels are enabled, usage will be reported on all the enabled levels even if only one of the levels is breached. Monitoring will be stopped on the missing threshold levels in the response for the usage report from PCRF (expected to provide the complete set again if PCRF wants to continue monitoring on the multiple levels enabled earlier).

Total threshold level along with UL/DL threshold level in the GSU AVP is treated as an error and only total threshold level is accepted.

An extra CCR-U was generated for a monitoring key when the following requests are received in the response to the CCR-U which reported the usage for the same monitoring key.

- immediate reporting request with monitoring key at rule level
- immediate reporting request with or without monitoring key at session level
- explicit disable request at rule level
- explicit disable request at session level

An extra CCR-U is not generated for a monitoring key when all the above mentioned requests are received in the response to the CCR-U which reported the usage for the same monitoring key. Also, extra CCR-U is not generated when immediate reporting request without monitoring key at rule level is received in the response to the CCR-U which reported the usage for all the active monitoring keys.

- Usage Monitoring at Flow Level: PCRF subscribes to the flow-level volume reporting over Gx by sending the Usage-Monitoring-Information AVP with the usage threshold level set in Granted-Service-Unit AVP and Usage-Monitoring-Level AVP set to PCC_RULE_LEVEL(1). Monitoring Key is mandatory in case of a flow-level monitoring since the rules are associated with the monitoring key and enabling/disabling of usage monitoring at flow level can be controlled by PCRF using it. After the AVPs are parsed by DPCA, IMSA updates the information to ECS. Once ECS is updated usage monitoring is started and constantly checked with the usage threshold whenever the data traffic is present.

Usage monitoring is supported for static, predefined rules, and dynamic rule definitions.

- **Usage Monitoring for Static Rules:** In the case of static rules, the usage reporting on last rule removal associated with the monitoring key is not applicable. In this case only the usage monitoring information is received from the PCRF.
- **Usage Monitoring for Predefined Rules:** If the usage monitoring needs to be enabled for the predefined rules, PCRF sends the rule and the usage monitoring information containing the monitoring key and the usage threshold. The Monitoring key should be the same as the one pre-configured in PCEF for that predefined rule. There can be multiple rules associated with the same monitoring key. Hence enabling a particular monitoring key would result in the data being tracked for multiple rules having the same monitoring key. After DPCA parses the AVPs IMSA updates the information to ECS. Once ECS is updated usage monitoring is started and constantly checked with the usage threshold whenever the data traffic is present.
- **Usage Monitoring for Dynamic Rules:** If the usage monitoring needs to be enabled for dynamic ruledefs, PCRF provides the monitoring key along with a charging rule definition and the usage monitoring information containing the monitoring key and the usage threshold. This would result in the usage monitoring being done for all the rules associated with that monitoring key. After DPCA parses the AVPs, IMSA updates the information to ECS. Once ECS is updated, the usage monitoring is started and constantly checked with the usage threshold whenever the data traffic is present. Monitoring key for dynamic ruledef is dynamically assigned by PCRF which is the only difference with predefined rules in case of usage monitoring.

If threshold breach happens for multiple monitoring keys at the same time, only one of the monitoring keys' usage is reported first. Upon receiving successful response from PCRF, the rest of the monitoring keys' usage is reported to PCRF. On Tx expiry/TCP link error, unreported usage is stored at ECS. Any future successful interaction with PCRF for the session will send unreported UMI to PCRF.

Usage Reporting

Usage at subscriber/flow level is reported to PCRF under the following conditions:

- **Usage Threshold Reached:** PCEF records the subscriber data usage and checks if the usage threshold provided by PCRF is reached. This is done for both session and rule level reporting.

For session-level reporting, the actual usage volume is compared with the usage volume threshold.

For rule-level reporting the rule that hits the data traffic is used to find out if the monitoring key is associated with it, and based on the monitoring key the data usage is checked. Once the condition is met, it reports the usage information to IMSA and continues monitoring. IMSA then triggers the CCR-U if "USAGE_REPORT" trigger is enabled by the PCRF. The Usage-Monitoring-Information AVP is sent in this CCR with the "Used-Service-Unit" set to the amount of data usage by subscriber.

If PCRF does not provide a new usage threshold in the usage monitoring information as a result of CCR from PCEF when the usage threshold is reached, the usage monitoring is stopped at PCEF and no usage status is reported.

In the non-standard Volume Reporting over Gx implementation, usage monitoring will be stopped once the threshold is breached, else the monitoring will continue. There will be no further usage reporting until the CCA is received.

- **Usage Monitoring Disabled:** If the PCRF explicitly disables the usage monitoring with Usage-Monitoring-Support AVP set to USAGE_MONITORING_DISABLED, the PCEF stops monitoring and reports the usage information (when the monitoring was enabled) to PCRF if the usage monitoring is disabled by PCRF as a result of CCR from PCEF which is not related to reporting usage, other external triggers, or a PCRF internal trigger. If the PCRF does not provide a new usage threshold as a result of

CCR from PCEF when the usage threshold is reached, the usage monitoring is stopped at PCEF and no further usage status is reported.

- **IP CAN Session Termination:** When the IP CAN session is terminated, the accumulated subscriber usage information is reported to PCRF in the CCR-T from PCEF. If PCC usage level information is enabled by PCRF, the PCC usage will also be reported.

PCRF uses RAR message and includes Session-Release-Cause AVP in it to initiate IP CAN Session Termination. However, there are some scenarios where PCRF may want to terminate the IP CAN Session in CCA messages. In order to avoid an unnecessary additional message, PCRF can inform P-GW to terminate the subscriber in CCA-U message itself. Hence, the Session Release Cause has been added in CCA messages for all Gx dictionaries.

- **PCC Rule Removal:** When the PCRF deactivates the last PCC rule associated with a usage monitoring key, the PCEF sends a CCR with the data usage for that monitoring key. If the PCEF reports the last PCC rule associated with a usage monitoring key is inactive, the PCEF reports the accumulated usage for that monitoring key within the same CCR command if the Charging-Rule-Report AVP was included in a CCR command; otherwise, if the Charging-Rule-Report AVP was included in an RAA command, the PCEF sends a new CCR command to report accumulated usage for the usage monitoring key. The usage reporting on last rule deactivation using rule deactivation time set by PCRF is supported.

On receiving message from PCRF, the rule that is meant for removal is marked and then after the access side procedure is complete the rule is removed.

- **PCRF Requested Usage Report:** The accumulated usage since the last report is sent even in case of immediate reporting, the usage is reset after immediate reporting and usage monitoring continued so that the subsequent usage report will have the usage since the current report.
- **Usage reporting on bearer termination can be added.** When a bearer is deleted due to some reason, the rules associated with the bearer will also be removed. So, the usage will be reported on the monitoring key(s) whose associated rule is the last one that is removed because of bearer termination.
- **Revalidation Timeout:** In the non-standard implementation, if usage monitoring and reporting is enabled and a revalidation timeout occurs, the PCEF sends a CCR to request PCC rules and reports all accumulated usage for all enabled monitoring keys since the last report (or since usage reporting was enabled if the usage was not yet reported) with the accumulated usage at IP-CAN session level (if enabled) and at service data flow level (if enabled) This is the default behavior.

In the case of standard implementation, this must be enabled by CLI configuration.



Important The Usage Reporting on Revalidation Timeout feature is available by default in non-standard implementation of Volume Reporting over Gx. This is configurable in the standard implementation.

Once the usage is reported, the usage counter is reset to zero. The PCEF continues to track data usage from the zero value after the threshold is reached and before a new threshold is provided by the PCRF. If a new usage threshold is not provided by the PCRF in the acknowledgement of an IP-CAN Session modification where its usage was reported, then usage monitoring does not continue in the PCEF for that IP CAN session and the usage accumulated between the CCR-CCA will be discarded.

CCR-U triggered on server retries takes server granted quota into account for reporting USU. For newly created MSCC, interim quota configuration is taken as reference for reporting USU.

For information on how to configure the Volume Reporting over Gx feature, see [Configuring Volume Reporting over Gx](#), on page 523.

ICSR Support for Volume Reporting over Gx (VoRoGx)

Volume threshold and volume usage are synced to standby chassis to support volume reporting over Gx for existing sessions post switchover.

Without this support it cannot cause a subscriber to use higher speeds than what s/he is supposed to get, if volume reporting is for example used to enforce fair usage; the operator may already consider this a revenue loss. It will also severely impact roaming subscribers who are supposed to get a notification and be blocked/redirected once the limits set by the EU roaming regulation are reached. If a session continues now without being blocked, the operator is not allowed to charge for data beyond the limit and will have a significant and real revenue loss (roaming partner may still charge for the data used on their SGSNs).

How Rel. 7 Gx Works

This section describes how dynamic policy and charging control for subscribers works with Rel. 7 Gx interface support in GPRS/UMTS networks.

The following figure and table explain the IMSA process between a system and IMS components that is initiated by the UE.

In this example, the Diameter Policy Control Application (DPCA) is the Gx interface to the PCRF. The interface between IMSA with PCRF is the Gx interface, and the interface between Session Manager (SessMgr) and Online Charging Service (OCS) is the Gy interface. Note that the IMSA service and DPCA are part of SessMgr on the system and separated in the figure for illustration purpose only.



Important The DPCA and the IMSA will be acting as one module within the Policy Server interface application.

Figure 97: Rel. 7 Gx IMS Authorization Call Flow

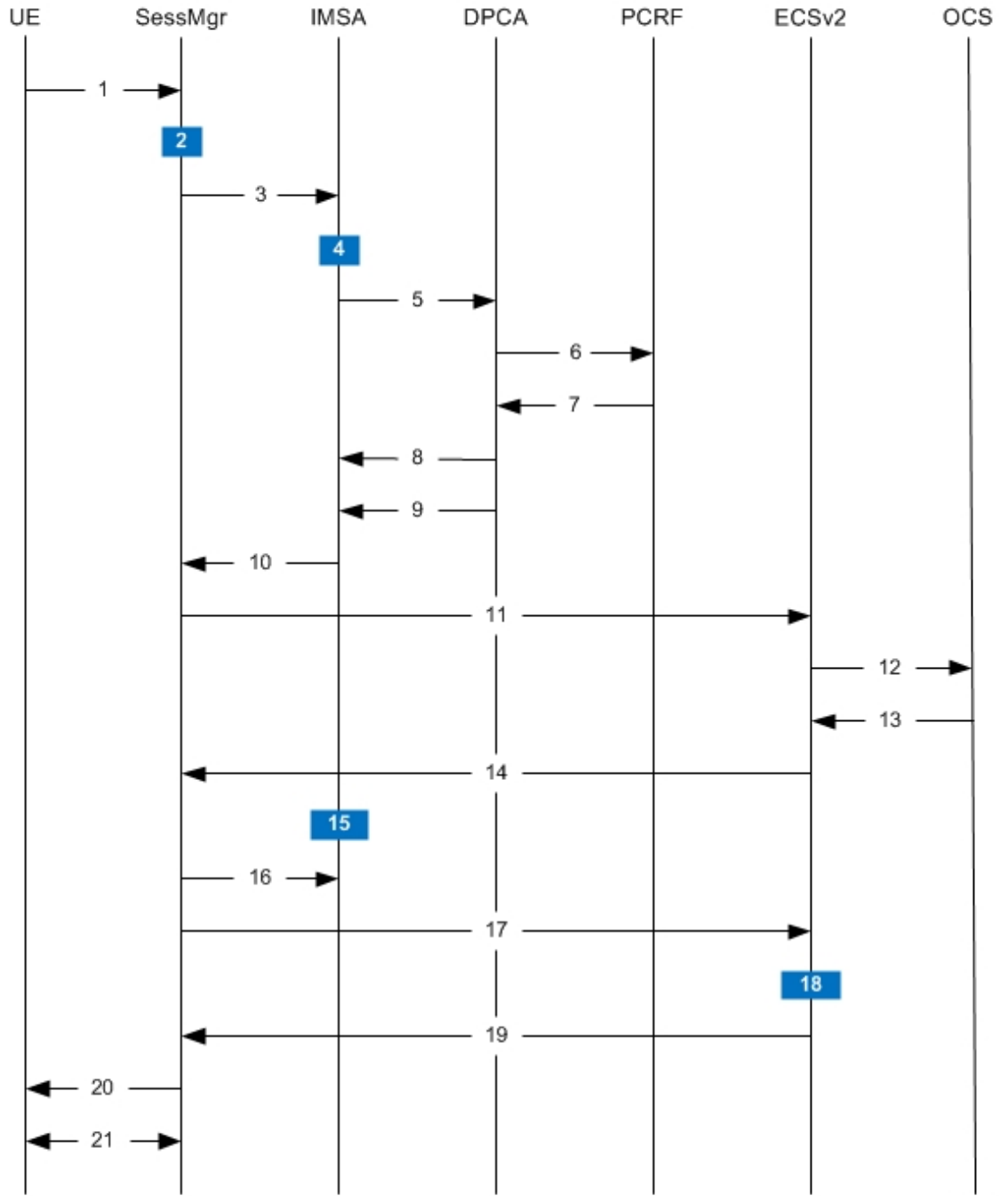

335182

Table 53: Rel. 7 Gx IMS Authorization Call flow Description

Step	Description
1	UE (IMS subscriber) requests for primary PDP context activation/creation.

Step	Description
2	SessMgr allocates an IP address to the UE.
3	SessMgr requests IMS Authorization, if IMSA is enabled for the APN.
4	IMSA allocates resources for the IP CAN session and the bearer, and selects the PCRF to contact based on the user's selection key (for example, msisdn).
5	IMSA requests the DPCA module to issue an auth request to the PCRF.
6	DPCA sends a CCR initial message to the selected PCRF. This message includes the Context-Type AVP set to PRIMARY and the IP address allocated to the UE. The message may include the Bearer-Usage AVP set to GENERAL. The Bearer-Operation is set to Establishment. The Bearer ID is included if the PCRF does the bearer binding.
7	PCRF may send preconfigured charging rules in CCA, if a preconfigured rule set for general purpose PDP context is provided in PCRF. The dynamic rules and the authorized QoS parameters could also be included by the PCRF.
8	DPCA passes the charging rule definition, charging rule install, QoS information received from the PCRF, event triggers, and so on, along with the Bearer ID that corresponds to the rules received from the PCRF to IMSA. IMSA stores the information. If the Bearer ID is absent, and PCRF does the bearer binding, the rule is skipped. Whereas, if the Bearer ID is absent and the PCEF does the bearer binding, the rule is passed onto the ECS to perform bearer binding.
9	DPCA calls the callback function registered with it by IMSA.
10	IMSA stores the bearer authorized QoS information and notifies the SessMgr. Other PCRF provided information common to the entire PDP session (event trigger, primary/secondary OCS address, and so on) is stored within the IMSA. After processing the information, IMSA notifies the SessMgr about the policy authorization complete.
11	If the validation of the rules fails in IMSA/DPCA, a failure is notified to PCRF containing the Charging-Rule-Report AVP. Else, IMSA initiates creation of ECS session. The APN name, primary/secondary OCS server address, and so on are sent to the ECS from the SessMgr.
12	ECS performs credit authorization by sending CCR(I) to OCS with CC-Request-Type set to INITIAL_REQUEST to open the credit control session. This request includes the active Rulebase-Id (default rulebase ID from the APN/AAA) and GPRS specific attributes (for example, APN, UMTS QoS, and so on).
13	OCS returns a CCA initial message that may activate a statically configured Rulebase and may include preemptive quotas.
14	ECS responds to SessMgr with the response message.
15	SessMgr requests IMSA for the dynamic rules.
16	IMSA sends the dynamic rules to SessMgr. Note that the RAR messages are allowed before the session is established. Also note that the RAR message is rejected and RAA is sent with 3002 result code when the recovery of dynamic rule information and audit of Session Manager are in progress.

Step	Description
17	SessMgr sends the dynamic rule information to the ECS. The gate flow status information and the QoS per flow (charging rule) information are also sent in the message.
18	ECS activates the predefined rules received, and installs the dynamic rules received. Also, the gate flow status and the QoS parameters are updated by ECS as per the dynamic charging rules. The Gx rulebase is treated as an ECS group-of-ruledefs. The response message contains the Charging Rule Report conveying the status of the rule provisioning at the ECS. ECS performs PCEF bearer binding for rules without bearer ID.
19	If the provisioning of rules fails partially, the context setup is accepted, and a new CCR-U is sent to the PCRF with the Charging-Rule-Report containing the PCC rule status for the failed rules. If the provisioning of rules fails completely, the context setup is rejected.
20	Depending on the response for the PDP Context Authorization, SessMgr sends the response to the UE and activates/rejects the call. If the Charging-Rule-Report contains partial failure for any of the rules, the PCRF is notified, and the call is activated. If the Charging-Rule-Report contains complete failure, the call is rejected.
21	Based on the PCEF bearer binding for the PCC rules at Step 18, the outcome could be one or more network-initiated PDP context procedures with the UE (Network Requested Update PDP Context (NRUPC) / Network Requested Secondary PDP Context Activation (NRSPCA)).

Configuring Rel. 7 Gx Interface

To configure Rel. 7 Gx interface functionality, the IMS Authorization service must be configured at the context level, and then the APN configured to use the IMS Authorization service.

To configure Rel. 7 Gx interface functionality:

-
- Step 1** Configure IMS Authorization service at the context level for IMS subscriber in GPRS/UMTS network as described in [Configuring IMS Authorization Service at Context Level, on page 520](#).
 - Step 2** Verify your configuration as described in [Verifying the Configuration, on page 522](#).
 - Step 3** Configure an APN within the same context to use the IMS Authorization service for IMS subscriber as described in [Applying IMS Authorization Service to an APN, on page 522](#).
 - Step 4** Verify your configuration as described in [Verifying Subscriber Configuration, on page 523](#).
 - Step 5** *Optional:* Configure the Volume Reporting over Gx feature as described in [Configuring Volume Reporting over Gx, on page 523](#).
 - Step 6** Save your configuration to flash memory, an external memory device, and/or a network location using the Exec mode command **save configuration**. For additional information on how to verify and save configuration files, refer to the *System Administration Guide* and the *Command Line Interface Reference*.

Important Commands used in the configuration examples in this section provide base functionality to the extent that the most common or likely commands and/or keyword options are presented. In many cases, other optional commands and/or keyword options are available. Refer to the *Command Line Interface Reference* for complete information regarding all commands.

Configuring IMS Authorization Service at Context Level

Use the following example to configure IMS Authorization service at context level for IMS subscribers in GPRS/UMTS networks:

```
configure
  context <context_name>
    ims-auth-service <imsa_service_name>
      p-cscf discovery table { 1 | 2 } algorithm {
ip-address-modulus | msisdn-modulus | round-robin }
      p-cscf table { 1 | 2 } row-precedence <precedence_value> {
address <ip_address> | ipv6-address <ipv6_address> } [ secondary { address
<ip_address> | ipv6-address <ipv6_address> } ]
      policy-control
        diameter origin endpoint <endpoint_name>
        diameter dictionary <dictionary>
        diameter request-timeout <timeout_duration>
        diameter host-select table { { { 1 | 2 } algorithm {
ip-address-modulus | msisdn-modulus | round-robin } } | prefix-table {
1 | 2 } }
          diameter host-select row-precedence <precedence_value>
table { { { 1 | 2 } host <host_name> [ realm <realm_id> ] [ secondary host
<host_name> [ realm <realm_id> ] ] } | { prefix-table { 1 | 2 }
msisdn-prefix-from <msisdn_prefix_from> msisdn-prefix-to <msisdn_prefix_to> host
<host_name> [ realm <realm_id> ] [ secondary host <sec_host_name> [ realm
<sec_realm_id> ] algorithm { active-standby | round-robin } ] } } [ -noconfirm
]
          diameter host-select reselect subscriber-limit
<subscriber_limit> time-interval <duration>
          failure-handling cc-request-type { any-request |
initial-request | terminate-request | update-request } {
diameter-result-code { any-error | <result_code> [ to <end_result_code> ] } }
{ continue | retry-and-terminate | terminate }
        end
      end
    end
  end
```

Notes:

- <context_name> must be the name of the context where you want to enable IMS Authorization service.
- <imsa_service_name> must be the name of the IMS Authorization service to be configured for Rel. 7 Gx interface authentication.
- A maximum of 30 IMS authorization service profiles can be configured within the system.
- Secondary P-CSCF IP address can be configured in the P-CSCF table. Refer to the *Command Line Interface Reference* for more information on the **p-cscf table** command.

The syntax for **p-cscf table** configuration command is:

```
p-cscf table { 1 | 2 } row-precedence precedence_value { ipv4-address
ipv4_address [ ipv6-address ipv6_address ] | ipv6-address ipv6_address [
ipv4-address ipv4_address ] } [ secondary { ipv4-address ipv4_address [
ipv6-address ipv6_address ] | ipv6-address ipv6_address [ ipv4-address
ipv4_address ] } [ weight value ]
```

- To enable Rel. 7 Gx interface support, pertinent Diameter dictionary must be configured. For information on the specific Diameter dictionary to use, contact your Cisco account representative.

- When configuring the MSISDN prefix range based PCRF selection mechanism:

To enable the Gx interface to connect to a specific PCRF for a range of subscribers configure **msisdn-prefix-from** *<msisdn_prefix_from>* and **msisdn-prefix-to** *<msisdn_prefix_to>* with the starting and ending MSISDNs respectively.

To enable the Gx interface to connect to a specific PCRF for a specific subscriber, configure both **msisdn-prefix-from** *<msisdn_prefix_from>* and **msisdn-prefix-to** *<msisdn_prefix_to>* with the same MSISDN.

A maximum of 128 rows can be added to the MSISDN prefix range table.

The MSISDN ranges must not overlap between rows.

- The Round Robin algorithm for PCRF selection is effective only over a large number of PCRF selections, and not at a granular level.

- *Optional:* To configure the Quality of Service (QoS) update timeout for a subscriber, in the IMS Authorization Service Configuration Mode, enter the following command:

- *Optional:* To configure signalling restrictions, in the IMS Authorization Service Configuration Mode, enter the following commands:

signaling-flag { deny | permit }

signaling-flow permit server-address *<ip_address>* [**server-port** { *<port_number>* | **range** *<start_number>* **to** *<end_number>* }] [**description** *<string>*]

- *Optional:* To configure action on packets that do not match any policy gates in the general purpose PDP context, in the IMS Authorization Service Configuration Mode, enter the following command:

traffic-policy general-pdp-context no-matching-gates direction { **downlink** | **uplink** } { **forward** | **discard** }

- To configure the PCRF host destinations configured in the GGSN/PCEF, use the **diameter host-select** CLI commands.

- To configure the GGSN/PCEF to use a pre-defined rule when the Gx fails, set the **failure-handling cc-request-type** CLI to **continue**. Policies available/in use will continue to be used and there will be no further interaction with the PCRF.

- For provisioning of default charging method, use the following configurations. For this, the AVPs Online and Offline will be sent in CCR-I message based on the configuration. The Online/Offline AVP received at command level applies only to dynamic rules if they are not configured at PCC rule level.

- To send Enable Online:

configure

active-charging service *<ecs_service_name>*

charging-action *<charging_action_name>*

cca charging credit

exit

- To send Enable Offline:

```

configure
active-charging service <ecs_service_name>
rulebase <rulebase_name>
billing-records rf
exit

```

Verifying the Configuration

To verify the IMS Authorization service configuration:

Step 1 Change to the context where you enabled IMS Authorization service by entering the following command:

```
context <context_name>
```

Step 2 Verify the IMS Authorization service's configurations by entering the following command:

```
show ims-authorization service name <imsa_service_name>
```

Applying IMS Authorization Service to an APN

After configuring IMS Authorization service at the context-level, an APN must be configured to use the IMS Authorization service for an IMS subscriber.

Use the following example to apply IMS Authorization service functionality to a previously configured APN within the context configured as described in [Configuring Rel. 7 Gx Interface, on page 519](#).

```

configure
  context <context_name>
    apn <apn_name>
      ims-auth-service <imsa_service_name>
      active-charging rulebase <rulebase_name>
    end

```

Notes:

- <context_name> must be the name of the context in which the IMS Authorization service was configured.
- <imsa_service_name> must be the name of the IMS Authorization service configured for IMS authentication in the context.
- For Rel. 7 Gx, the ECS rulebase must be configured in the APN.
- ECS allows change of rulebase via Gx for PCEF binding scenarios. When the old rulebase goes away, all the rules that were installed from that rulebase are removed. This may lead to termination of a few bearers (PDP contexts) if they are left without any rules. If there is a Gx message that changes the rulebase, and also activates some predefined rules, the rulebase change is made first, and the rules are activated from the new rulebase. Also, the rulebase applies to the entire call. All PDP contexts (bearers) in one call use the same ECS rulebase.
- For predefined rules configured in the ECS, MBR/GBR of a dynamic/predefined rule is checked before it is used for PCEF binding. All rules (dynamic as well as predefined) have to have an MBR associated

with them and all rules with GBR QCI should have GBR also configured. So for predefined rules, one needs to configure appropriate peak-data-rate, committed-data-rate as per the QCI being GBR QCI or non-GBR QCI. For more information, in the ACS Charging Action Configuration Mode, see the **flow limit-for-bandwidth** CLI command.

- For interpretation of the Gx rulebase (Charging-Rule-Base-Name AVP) from PCRF as ECS group-of-ruledefs, configure the following command in the Active Charging Service Configuration Mode:
policy-control charging-rule-base-name active-charging-group-of-ruledefs

Verifying Subscriber Configuration

Verify the IMS Authorization service configuration for subscriber(s) by entering the following command:

```
show subscribers ims-auth-service <imsa_service_name>
```

<imsa_service_name> must be the name of the IMS Authorization service configured for IMS authentication.

Configuring Volume Reporting over Gx

This section describes the configuration required to enable Volume Reporting over Gx.

To enable Volume Reporting over Gx, use the following configuration:

```
configure
  active-charging service <ecs_service_name>
    rulebase <rulebase_name>
      action priority <priority> dynamic-only ruledef <ruledef_name>
  charging-action <charging_action_name> monitoring-key <monitoring_key>
  exit
  exit
  context <context_name>
    ims-auth-service <imsa_service_name>
      policy-control
        event-update send-usage-report [ reset-usage ]
      end
```

Notes:

- The maximum accepted monitoring key value by the PCEF is 4294967295. If the PCEF sends a greater value, the value is converted to an Unsigned Integer value.
- The **event-update** CLI is available to enable volume usage report to be sent in event updates. The optional keyword **reset-usage** enables to support delta reporting wherein the usage is reported and reset at PCEF. If this option is not configured, the behavior is to send the usage information as part of event update but not reset at PCEF.

Gathering Statistics

This section explains how to gather Rel. 7 Gx statistics and configuration information.

In the following table, the first column lists what statistics to gather, and the second column lists the action to perform.

Table 54: Gathering Rel. 7 Gx Statistics and Information

Statistics/Information	Action to perform
Information and statistics specific to policy control in IMS Authorization service.	show ims-authorization policy-control statistics
Information and statistics specific to the authorization servers used for IMS Authorization service.	show ims-authorization servers ims-auth-service
Information of all IMS Authorization service.	show ims-authorization service all
Statistics of IMS Authorization service.	show ims-authorization service statistics
Information, configuration, and statistics of sessions active in IMS Authorization service.	show ims-authorization sessions all
Complete information, configuration, and statistics of sessions active in IMS Authorization service.	show ims-authorization sessions full
Summarized information of sessions active in IMS Authorization service.	show ims-authorization sessions summary
Complete statistics for active charging service sessions.	show active-charging sessions full
Information for all rule definitions configured in the service.	show active-charging ruledef all
Information for all rulebases configured in the system.	show active-charging rulebase all
Information on all group of ruledefs configured in the system.	show active-charging group-of-ruledefs all

Rel. 8 Gx Interface

Rel. 8 Gx interface support is available on the Cisco ASR chassis.

This section describes the following topics:

- [HA/PDSN Rel. 8 Gx Interface Support, on page 524](#)
- [P-GW Rel. 8 Gx Interface Support, on page 540](#)

HA/PDSN Rel. 8 Gx Interface Support

This section provides information on configuring Rel. 8 Gx interface for HA and PDSN to support policy and charging control for subscribers in CDMA networks.

The IMS service provides application support for transport of voice, video, and data independent of access support. Roaming IMS subscribers in CDMA networks require apart from other functionality sufficient, uninterrupted, consistent, and seamless user experience during an application session. It is also important that a subscriber gets charged only for the resources consumed by the particular IMS application used.

It is recommended that before using the procedures in this section you select the configuration example that best meets your service model, and configure the required elements for that model as described in this Administration Guide.

This section describes the following topics:

- [Introduction, on page 525](#)
- [Terminology and Definitions, on page 527](#)
- [How it Works, on page 534](#)
- [Configuring HA/PDSN Rel. 8 Gx Interface Support, on page 537](#)
- [Gathering Statistics, on page 539](#)

Introduction

For IMS deployment in CDMA networks the system uses Rel. 8 Gx interface for policy-based admission control support and flow-based charging (FBC). The Rel. 8 Gx interface supports enforcing policy control features like gating, bandwidth limiting, and so on, and also supports FBC. This is accomplished via dynamically provisioned Policy Control and Charging (PCC) rules. These PCC rules are used to identify Service Data Flows (SDF) and to do charging. Other parameters associated with the rules are used to enforce policy control.

The PCC architecture allows operators to perform service-based QoS policy and FBC control. In the PCC architecture, this is accomplished mainly by the Policy and Charging Enforcement Function (PCEF)/HA/PDSN and the Policy and Charging Rules Function (PCRF). The client functionality lies with the HA/PDSN, therefore in the IMS Authorization (IMSA) scenario it is also called the Gateway. The PCEF function is provided by the Enhanced Charging Service (ECS). The Gx interface is implemented as a Diameter connection. The Gx messaging mostly involves installing/modifying/removing dynamic rules and activating/deactivating predefined rules.

The Gx reference point is located between the Gateway/PCEF and the PCRF. This reference point is used for provisioning and removal of PCC rules from the PCRF to the Gateway/PCEF, and the transmission of traffic plane events from the Gateway/PCEF to the PCRF. The Gx reference point can be used for charging control, policy control, or both by applying AVPs relevant to the application.

The following figure shows the reference points between elements involved in the policy and charging architecture.

Figure 98: HA/PDSN Rel. 8 Gx PCC Logical Architecture

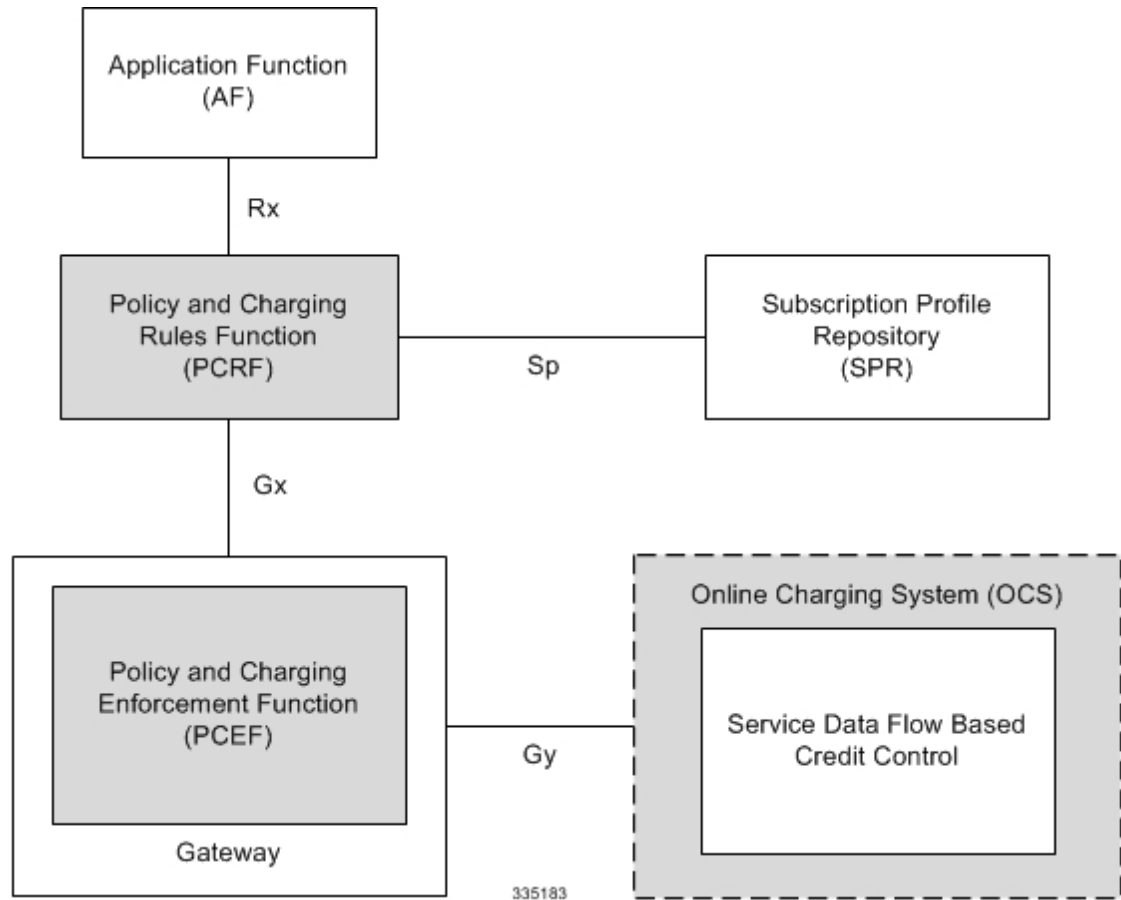

Within the Gateway, the IMSA and DPCA modules handle the Gx protocol related functions (at the SessMgr) and the policy enforcement and charging happens at ECS. The Gy protocol related functions are handled within the DCCA module (at the ECS).

The following figure shows the interaction between components within the Gateway.

Figure 99: HA/PDSN Rel. 8 Gx PCC Architecture within PCEF

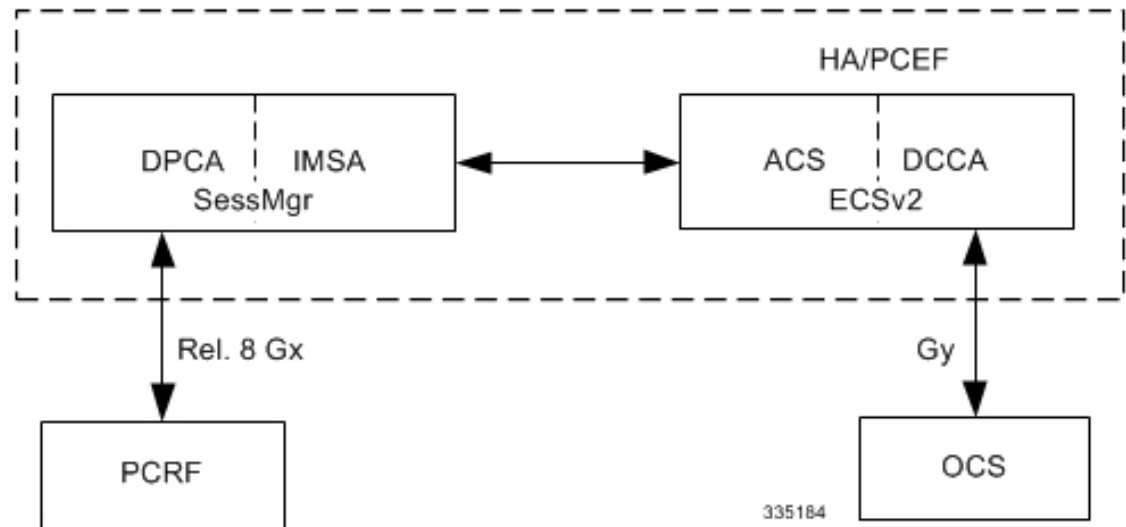

License Requirements

The HA/PDSN Rel. 8 Gx interface support is a licensed Cisco feature. A separate feature license may be required. Contact your Cisco account representative for detailed information on specific licensing requirements. For information on installing and verifying licenses, refer to the *Managing License Keys* section of the *Software Management Operations* chapter in the *System Administration Guide*.

Supported Standards

HA/PDSN Rel 8. Gx interface support is based on the following standards and RFCs:

- 3GPP TS 23.203 V8.3.0 (2008-09) 3rd Generation Partnership Project; Technical Specification Group Services and System Aspects; Policy and charging control architecture (Release 8)
- 3GPP TS 29.212 V8.6.0 (2009-12) 3rd Generation Partnership Project; Technical Specification Group Core Network and Terminals; Policy and Charging Control over Gx reference point (Release 8)
- 3GPP TS 29.213 V8.1.1 (2008-10) 3rd Generation Partnership Project; Technical Specification Group Core Network and Terminals; Policy and Charging Control signalling flows and QoS parameter mapping; (Release 8)
- RFC 3588, Diameter Base Protocol; September 2003
- RFC 4006, Diameter Credit-Control Application; August 2005

Terminology and Definitions

This section describes features and terminology pertaining to HA/PDSN Rel. 8 Gx functionality.

Policy Control

The process whereby the PCRF indicates to the PCEF how to control the IP-CAN session.

Policy control comprises the following functions:

- Binding

- Gating Control
- Event Reporting
- QoS Control
- Other Features

Binding

In the HA/PDSN Rel. 8 Gx implementation, since there are no bearers within a MIP session the IP-CAN Bearer concept does not apply. Only authorized IP-CAN session is applicable.

Gating Control

Gating control is the blocking or allowing of packets belonging to an SDF, to pass through to the desired endpoint. A gate is described within a PCC rule and gating control is applied on a per SDF basis. The commands to open or close the gate leads to the enabling or disabling of the passage for corresponding IP packets. If the gate is closed, all packets of the related IP flows are dropped. If the gate is open, the packets of the related IP flows are allowed to be forwarded.

Event Reporting



Important Unconditional reporting of event triggers from PCRF to PCEF when PCEF has not requested for is not supported.



Important In the HA/PDSN Rel. 8 Gx implementation, only the AN_GW_CHANGE (21) event trigger is supported.

Event reporting is the notification of and reaction to application events to trigger new behavior in the user plane as well as the reporting of events related to the resources in the Gateway (PCEF). Event triggers may be used to determine which IP-CAN session modification or specific event causes the PCEF to re-request PCC rules. Event trigger reporting from PCEF to PCRF, and provisioning of event triggers happens at IP-CAN session level.

The Event Reporting Function (ERF) located in the PCEF, receives event triggers from PCRF during the Provision of PCC Rules procedure and performs event trigger detection. When an event matching the received event trigger occurs, the ERF reports the occurred event to the PCRF. If the provided event triggers are associated with certain parameter values then the ERF includes those values in the response to the PCRF.

QoS Control



Important In the HA/PDSN Rel. 8 Gx implementation, only authorized IP-CAN Session is supported. Provisioning of authorized QoS per IP-CAN bearer, policy enforcement for authorized QoS per QCI, and coordination of authorized QoS scopes in mixed mode are not applicable.

QoS control is the authorization and enforcement of the maximum QoS that is authorized for an SDF. In case of an aggregation of multiple SDFs, the combination of the authorized QoS information of the individual

SDFs is provided as the authorized QoS for this aggregate. QoS control per SDF allows the PCC architecture to provide the PCEF with the authorized QoS to be enforced for each specific SDF.

QoS authorization information may be dynamically provisioned by the PCRF, or it can be a predefined PCC rule in the PCEF. For a predefined PCC rule within the PCEF, the authorized QoS information takes affect when the PCC rule is activated. The PCEF combines the different sets of authorized QoS information, that is the information received from the PCRF and the information corresponding to the predefined PCC rules. The PCRF knows the authorized QoS information of the predefined PCC rules and takes this information into account when activating them. This ensures that the combined authorized QoS of a set of PCC rules that are activated by the PCRF is within the limitations given by the subscription and operator policies regardless of whether these PCC rules are dynamically provided, predefined, or both.

Supported features include:

- Provisioning and Policy Enforcement of Authorized QoS: The PCRF may provide authorized QoS to the PCEF. The authorized QoS provides appropriate values for resources to be enforced.
- Policy Provisioning for Authorized QoS Per SDF: The provisioning of authorized QoS per SDF is a part of PCC rule provisioning procedure.
- Policy Enforcement for Authorized QoS Per SDF: If an authorized QoS is defined for a PCC rule, the PCEF limits the data rate of the SDF corresponding to that PCC rule not to exceed the maximum authorized bandwidth for the PCC rule by discarding packets exceeding the limit.
- Upon deactivation or removal of a PCC rule, the PCEF frees the resources reserved for that PCC rule.

Other Features

This section describes some of the other features.

PCC Rule Error Handling

If the installation/activation of one or more PCC rules fails, the PCEF communicates the failure to the PCRF by including one or more Charging-Rule-Report AVP(s) in either a CCR or an RAA command for the affected PCC rules. Within each Charging-Rule-Report AVP, the PCEF identifies the failed PCC rule(s) by including the Charging-Rule-Name AVP(s) or Charging-Rule-Base-Name AVP(s), identifies the failed reason code by including a Rule-Failure-Code AVP, and includes the PCC-Rule-Status AVP.

If the installation/activation of one or more new PCC rules (that is, rules that were not previously successfully installed) fail, the PCEF sets the PCC-Rule-Status to INACTIVE for both the PUSH and the PULL modes.

If a PCC rule was successfully installed/activated, but can no longer be enforced by the PCEF, the PCEF sends the PCRF a new CCR command and includes the Charging-Rule-Report AVP. The PCEF includes the Rule-Failure-Code AVP within the Charging-Rule-Report AVP and sets the PCC-Rule-Status to INACTIVE.

CCR-U is generated and sent to PCRF for reporting rule failure when the collision happens during GnGp HO scenario.

This additional Gx message (CCR-U) triggered will require multiple CCR-Us to be configured when RAT_TYPE trigger is enabled. Otherwise, the subscriber call will be dropped whenever the collision happens during HO.

In the HA/PDSN Gx implementation, the following rule failure codes are supported:

- RATING_GROUP_ERROR (2)
- SERVICE_IDENTIFIER_ERROR (3)

- GW/PCEF_MALFUNCTION (4)
- RESOURCES_LIMITATION (5)

If the installation/activation of one or more PCC rules fails during RAR procedure, the RAA command is sent with the Experimental-Result-Code AVP set to DIAMETER_PCC_RULE_EVENT (5142).

Time of the Day Procedures

PCEF performs PCC rule request as instructed by the PCRF. Revalidation-Time when set by the PCRF, causes the PCEF to trigger a PCRF interaction to request PCC rules from the PCRF for an established IP-CAN session. The PCEF stops the timer once the PCEF triggers a REVALIDATION_TIMEOUT event.

When installed, the PCC rule is inactive. If Rule-Activation-Time / Rule-Deactivation-Time is specified, then the PCEF sets the rule active / inactive after that time.

If Rule-Deactivation-Time AVP is omitted in CCA/RAR, then any previous value for this AVP is no longer valid. The new behavior is compliant to the 3GPP specification for Gx, version 12.1.0.

If PCRF enables the same predefined rule again in RAR/CCA-U without Rule-Deactivation-Time AVP, then the deactivation-time for this rule, if any, will be removed.

For switching to the old behavior, PCRF should re-send the same value of Rule-Deactivation-Time AVP along with predef-rule name in the PCRF message (RAR, CCA-U).



Note This behavior change is applicable only to predefined rules.

Support for Firewall Policy on Gx

The Diameter AVP "SN-Firewall-Policy" has been added to the Diameter dynamic dictionary to support Firewall policy on Gx interface. This AVP can be encoded in CCA-I message to apply/overwrite the fw-and-nat policy that has either been statically assigned to the PDP context via APN configuration or dynamically assigned via RADIUS in Access-Accept. This AVP can also be parsed in any CCA-U or RAR message to modify the fw-and-nat policy that is currently assigned to the PDP context.

Charging Control



Important In the HA/PDSN Rel. 8 Gx implementation, offline charging is not supported.

Charging Control is the process of associating packets belonging to an SDF to a charging key, and applying online charging as appropriate. FBC handles differentiated charging of the bearer usage based on real-time analysis of the SDFs. In order to allow for charging control, the information in the PCC rule identifies the SDF and specifies the parameters for charging control. The PCC rule information may depend on subscription data.

Online charging is supported via the Gy interface. In the case of online charging, it is possible to apply an online charging action upon PCEF events (for example, re-authorization upon QoS change).

It is possible to indicate to the PCEF that interactions with the charging systems are not required for a PCC rule, that is to perform neither accounting nor credit control for this SDF, then neither online nor offline charging is performed.

Supported Features:

- Provisioning of charging-related information for the IP-CAN Session
- Provisioning of charging addresses: Primary or secondary event charging function name (Online Charging Server (OCS) addresses)



Important In the HA/PDSN Rel. 8 Gx implementation, provisioning of primary or secondary charging collection function name (Offline Charging Server (OFCS) addresses) over Gx is not supported.

- Provisioning of Default Charging Method: In this release, the default charging method is sent in CCR-I message. For this, new AVPs Online/Offline are sent in CCR-I message based on the configuration. The Online/Offline AVP received at command level applies only to dynamic rules if they are not configured at PCC rule level.

Charging Correlation

In the HA/PDSN Rel. 8 Gx implementation, Charging Correlation is not supported. PCRF provides the flow identifier, which uniquely identifies an IP flow in an IMS session.

Policy and Charging Control (PCC) Rules

A PCC rule enables the detection of an SDF and provides parameters for policy control and/or charging control. The purpose of the PCC rule is to:

- Detect a packet belonging to an SDF in case of both uplink and downlink IP flows based on SDF filters in the PCC rule (packet rule matching).
If no PCC rule matches the packet, the packet is dropped.
- Identify the service that the SDF contributes to.
- Provide applicable charging parameters for an SDF.
- Provide policy control for an SDF.

The PCEF selects a PCC rule for each packet received by evaluating received packets against SDF filters of PCC rules in the order of precedence of the PCC rules. When a packet matches an SDF filter, the packet matching process for that packet is completed, and the PCC rule for that filter is applied.

There are two types of PCC rules:

- Dynamic PCC Rules: Rules dynamically provisioned by the PCRF to the PCEF via the Gx interface. These PCC rules may be either predefined or dynamically generated in the PCRF. Dynamic PCC rules can be activated, modified, and deactivated at any time.
- Predefined PCC Rule: Rules preconfigured in the PCEF by the operators. Predefined PCC rules can be activated or deactivated by the PCRF at any time. Predefined PCC rules within the PCEF may be grouped allowing the PCRF to dynamically activate a set of PCC rules over the Gx reference point.



Important A third kind of rule, the static PCC rule can be preconfigured in the chassis by the operators. Static PCC rules are not explicitly known in the PCRF, and are not under control of the PCRF. Static PCC rules are bound to general purpose bearer with no Gx control.

A PCC rule consists of:

- Rule Name: The rule name is used to reference a PCC rule in the communication between the PCEF and PCRF.
- Service Identifier: The service identifier is used to identify the service or the service component the SDF relates to.
- Service Data Flow Filter(s): The service flow filter(s) is used to select the traffic for which the rule applies.
- Precedence: For different PCC rules with overlapping SDF filter, the precedence of the rule determines which of these rules is applicable. When a dynamic PCC rule and a predefined PCC rule have the same priority, the dynamic PCC rule takes precedence.
- Gate Status: The gate status indicates whether the SDF, detected by the SDF filter(s), may pass (gate is open) or will be discarded (gate is closed) in uplink and/or in downlink direction.
- QoS Parameters: The QoS information includes the QoS class identifier (authorized QoS class for the SDF), and authorized bitrates for uplink and downlink.
- Charging Key (rating group)
- Other charging parameters: The charging parameters define whether online charging interfaces are used, on what level the PCEF will report the usage related to the rule, etc.



Important Configuring the Metering Method and Reporting Level for dynamic PCC rules is not supported.

PCC rules also include Application Function (AF) record information for enabling charging correlation between the application and bearer layer if the AF has provided this information via the Rx interface. For IMS, this includes the IMS Charging Identifier (ICID) and flow identifiers.



Important ASR 5500 supports only eight flow information including the flow description per dynamic charging rule in a Gx message.

In the event of a session manager crash, up to 24 PCC rules can be recovered post ICSR.

With the increase in the limit of PCC rules that can be recovered, the rules are not lost and hence the charging applied to the end users are not impacted.

When modification for the PCC rules in pending-active state is received, the modified parameters will be buffered at P-GW. After the response for the pending request is received from the access network, P-GW will process the modification of the buffered parameters and if required generate another update towards network.

PCC Procedures over Gx Reference Point

Request for PCC Rules

The PCEF, via the Gx reference point, requests for PCC rules in the following instances:

- At IP-CAN session establishment
- At IP-CAN session modification

PCC rules can also be requested as a consequence of a failure in the PCC rule installation/activation or enforcement without requiring an event trigger.

Provisioning of PCC Rules

The PCRF indicates, via the Rel. 8 Gx reference point, the PCC rules to be applied at the PCEF. This may be using one of the following procedures:

- PULL (provisioning solicited by the PCEF): In response to a request for PCC rules being made by the PCEF, the PCRF provisions PCC rules in the CC-Answer.
- PUSH (unsolicited provisioning): The PCRF may decide to provision PCC rules without obtaining a request from the PCEF. For example, in response to information provided to the PCRF via the Rx reference point, or in response to an internal trigger within the PCRF. To provision PCC rules without a request from the PCEF, the PCRF includes these PCC rules in an RA-Request message. No CCR/CCA messages are triggered by this RA-Request.

For each request from the PCEF or upon unsolicited provisioning, the PCRF provisions zero or more PCC rules. The PCRF may perform an operation on a single PCC rule by one of the following means:

- To activate or deactivate a PCC rule that is predefined at the PCEF, the PCRF provisions a reference to this PCC rule within a Charging-Rule-Name AVP and indicates the required action by choosing either the Charging-Rule-Install AVP or the Charging-Rule-Remove AVP.
- To install or modify a PCRF-provisioned PCC rule, the PCRF provisions a corresponding Charging-Rule-Definition AVP within a Charging-Rule-Install AVP.
- To remove a PCC rule which has previously been provisioned by the PCRF, the PCRF provisions the name of this rule as value of a Charging-Rule-Name AVP within a Charging-Rule-Remove AVP.



Important

The maximum valid length for a charging rule name is 63 bytes. When the length of the charging rule name is greater than 63 bytes, a charging rule report with RESOURCES_LIMITATION as Rule-Failure-Code is sent. This charging rule report is sent only when the length of the rule name is lesser than 128 characters. When the charging rule name length is greater than or equal to 128 characters no charging rule report will be sent.

During session connect, P-GW combines the rule failure and out of credit in the same CCR-U and sends to PCRF.

Selecting a PCC Rule for Uplink IP Packets

If PCC is enabled, the PCEF selects the applicable PCC rule for each received uplink IP packet within an IP-CAN session by evaluating the packet against uplink SDF filters of PCRF-provided or predefined active PCC rules of this IP-CAN session in the order of the precedence of the PCC rules.



Important When a PCRF-provided PCC rule and a predefined PCC rule have the same precedence, the uplink SDF filters of the PCRF-provided PCC rule is applied first.

When a packet matches an SDF filter, the packet matching process for that packet is completed, and the PCC rule for that filter is applied. Uplink IP packets which do not match any PCC rule of the corresponding IP-CAN session are discarded.

Selecting a PCC Rule for Downlink IP Packets

If PCC is enabled, the PCEF selects a PCC rule for each received downlink IP packet within an IP-CAN session by evaluating the packet against downlink SDF filters of PCRF-provided or predefined active PCC rules of the IP-CAN session in the order of precedence of the PCC rules.



Important When a PCRF-provided PCC rule and a predefined PCC rule have the same precedence, the downlink SDF filters of the PCRF-provided PCC rule are applied first.

When a packet matches an SDF filter, the packet matching process for that packet is completed, and the PCC rule for that filter is applied. Downlink IP packets that do not match any PCC rule of the IP-CAN session are discarded.

The following procedures are also supported:

- Indication of IP-CAN Session Termination: When the IP-CAN session is being terminated the PCEF contacts the PCRF.
- Request of IP-CAN Session Termination: If the PCRF decides to terminate an IP-CAN session due to an internal trigger or trigger from the SPR, the PCRF informs the PCEF. The PCEF acknowledges to the PCRF and instantly removes/deactivates all the PCC rules that have been previously installed or activated on that IP-CAN session.

The PCEF applies IP-CAN specific procedures to terminate the IP-CAN session. The HA/PDSN sends a MIP Revocation Request with the teardown indicator set to indicate that the termination of the entire IP-CAN session is requested. Furthermore, the PCEF applies the "Indication of IP-CAN Session Termination" procedure.

- Use of the Supported-Features AVP during session establishment to inform the destination host about the required and optional features that the origin host supports.

How it Works

This section describes how HA/PDSN Rel. 8 Gx Interface support works.

The following figure and table explain the IMS Authorization process between a system and IMS components that is initiated by the UE.

In this example, the Diameter Policy Control Application (DPCA) is the Gx interface to the PCRF. The interface between IMSA with PCRF is the Gx interface, and the interface between Session Manager (SessMgr) and Online Charging Service (OCS) is the Gy interface. Note that the IMSA service and DPCA are part of SessMgr on the system and separated in the figure for illustration purpose only.



Important The DPCA and the IMSA will be acting as one module within the Policy Server interface application.

Figure 100: HA/PDSN Rel. 8 Gx IMS Authorization Call Flow

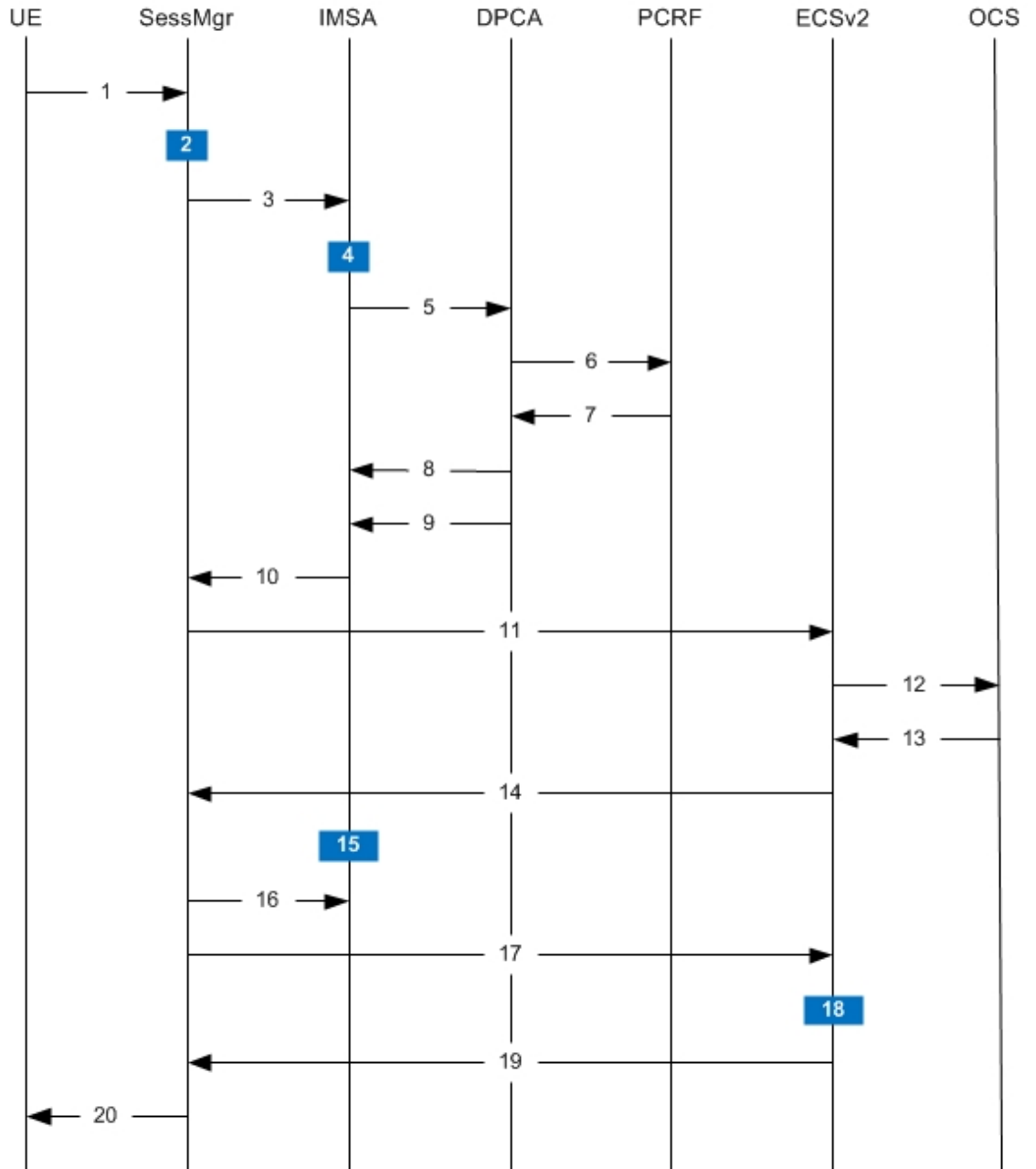

335185

Table 55: HA/PDSN Rel. 8 Gx IMS Authorization Call flow Description

Step	Description
1	UE (IMS subscriber) requests for MIP Registration Request.
2	SessMgr allocates an IP address to the UE.
3	SessMgr requests IMS Authorization, if IMSA is enabled for the subscriber. IMSA service can either be configured in the subscriber template, or can be received from the AAA.
4	IMSA allocates resources for the IP-CAN session, and selects the PCRF to contact based on the user's selection key (for example, round-robin).
5	IMSA requests the DPCA module to issue an auth request to the PCRF.
6	DPCA sends a CCR initial message to the selected PCRF.
7	PCRF may send preconfigured charging rules in CCA. The dynamic rules and the authorized QoS parameters could also be included by the PCRF.
8	DPCA passes the charging rule definition, charging rule install, QoS information received from the PCRF, event triggers, etc. IMSA stores the information.
9	DPCA calls the callback function registered with it by IMSA.
10	PCRF-provided information common to the entire IP-CAN session (event trigger, primary/secondary OCS address, etc.) is stored within the IMSA. After processing the information, IMSA notifies the SessMgr about the policy authorization complete.
11	If the validation of the rules fails in IMSA/DPCA, a failure is notified to PCRF containing the Charging-Rule-Report AVP. Else, IMSA initiates creation of ECS session. The primary/secondary OCS server address, etc. are sent to the ECS from the SessMgr.
12	ECS performs credit authorization by sending CCR(I) to OCS with CC-Request-Type set to INITIAL_REQUEST to open the credit control session. This request includes the active Rulebase-Id (default rulebase ID from the AAA).
13	OCS returns a CCA initial message that may activate a statically configured Rulebase and may include preemptive quotas.
14	ECS responds to SessMgr with the response message.
15	SessMgr requests IMSA for the dynamic rules.
16	IMSA sends the dynamic rules to SessMgr. The RAR messages are allowed before the session is established. Also note that, the RAR message is rejected and RAA is sent with 3002 result code when the recovery of dynamic rule information and audit of Session Manager are in progress.
17	SessMgr sends the dynamic rule information to the ECS. The gate flow status information and the QoS per flow (charging rule) information are also sent in the message.

Step	Description
18	ECS activates the predefined rules received, and installs the dynamic rules received. Also, the gate flow status and the QoS parameters are updated by ECS as per the dynamic charging rules. The Gx rulebase is treated as an ECS group-of-ruledefs. The response message contains the Charging Rule Report conveying the status of the rule provisioning at the ECS.
19	If the provisioning of rules fails partially, the context setup is accepted, and a new CCR-U is sent to the PCRF with the Charging-Rule-Report containing the PCC rule status for the failed rules. If the provisioning of rules fails completely, the context setup is rejected.
20	Depending on the response for the MIP Session Authorization, SessMgr sends the response to the UE and activates/rejects the call. If the Charging-Rule-Report contains partial failure for any of the rules, the PCRF is notified, and the call is activated. If the Charging-Rule-Report contains complete failure, the call is rejected.

Configuring HA/PDSN Rel. 8 Gx Interface Support

To configure HA/PDSN Rel. 8 Gx Interface functionality:

1. At the context level, configure IMSA service for IMS subscribers as described in [Configuring IMS Authorization Service at Context Level, on page 537](#).
2. Within the same context, configure the subscriber template to use the IMSA service as described in [Applying IMS Authorization Service to Subscriber Template, on page 539](#).
3. Save your configuration to flash memory, an external memory device, and/or a network location using the Exec mode command **save configuration**. For additional information on how to verify and save configuration files, refer to the *System Administration Guide* and the *Command Line Interface Reference*.



Important Commands used in the configuration examples in this section provide base functionality to the extent that the most common or likely commands and/or keyword options are presented. In many cases, other optional commands and/or keyword options are available. Refer to the *Command Line Interface Reference* for complete information regarding all commands.

Configuring IMS Authorization Service at Context Level

Use the following example to configure IMSA service at context level for IMS subscribers:

```

configure
  context <context_name>
    ims-auth-service <imsa_service_name>
      policy-control
        diameter origin endpoint <endpoint_name>
        diameter dictionary <dictionary>
        diameter request-timeout <timeout_duration>
        diameter host-select table { 1 | 2 } algorithm
round-robin
        diameter host-select row-precedence <precedence_value>
table { 1 | 2 } host <primary_host_name> [ realm <primary_realm_id> ] [ secondary
  host <secondary_host_name> [ realm <secondary_realm_id> ] ] [ -noconfirm ]

```

```

        failure-handling cc-request-type { any-request |
initial-request | terminate-request | update-request } {
diameter-result-code { any-error | <result_code> [ to <end_result_code> ] } }
{ continue | retry-and-terminate | terminate }
    exit
    exit
diameter endpoint <endpoint_name> [ -noconfirm ]
    origin realm <realm_name>
    use-proxy
    origin host <host_name> address <ip_address>
    no watchdog-timeout
    response-timeout <timeout_duration>
    connection timeout <timeout_duration>
    connection retry-timeout <timeout_duration>
    peer <primary_peer_name> [ realm <primary_realm_name> ] address
<ip_address> [ port <port_number> ]
    peer <secondary_peer_name> [ realm <secondary_realm_name> ] address
<ip_address> [ port <port_number> ]
    end

```

Notes:

- *<context_name>* must be the name of the context where you want to enable IMSA service.
- *<imsa_service_name>* must be the name of the IMSA service to be configured for Rel. 8 Gx interface authentication.
- A maximum of 30 IMS authorization service profiles can be configured within the system.
- To enable Rel. 8 Gx interface support, pertinent Diameter dictionary must be configured. For information on the specific Diameter dictionary to use, contact your Cisco account representative.
- The Round Robin algorithm for PCRF selection is effective only over a large number of PCRF selections, and not at a granular level.
- To configure the PCRF host destinations configured in the PCEF, use the **diameter host-select** CLI command.
- To configure the PCEF to use a pre-defined rule when the Gx fails, set the **failure-handling cc-request-type** CLI to **continue**. Policies available/in use will continue to be used and there will be no further interaction with the PCRF.

Verifying the IMSA Service Configuration

To verify the IMSA service configuration:

1. Change to the context where you enabled IMSA service by entering the following command:

```
context <context_name>
```
2. Verify the IMSA service configuration by entering the following command:

```
show ims-authorization service name <imsa_service_name>
```

Applying IMS Authorization Service to Subscriber Template

After configuring IMSA service at the context-level, within the same context subscriber template must be configured to use the IMSA service for IMS subscribers.

Use the following example to apply IMSA service functionality to subscriber template within the context configured as described in [Configuring IMS Authorization Service at Context Level, on page 537](#).

```
configure
  context <context_name>
    subscriber default
      encrypted password <encrypted_password>
      ims-auth-service <imsa_service_name>
      ip access-group <access_group_name> in
      ip access-group <access_group_name> out
      ip context-name <context_name>
      mobile-ip home-agent <ip_address>
      active-charging rulebase <rulebase_name>
    end
```

Notes:

- <context_name> must be the name of the context in which the IMSA service was configured.
- <imsa_service_name> must be the name of the IMSA service configured for IMS authentication in the context.
- The ECS rulebase must be configured in the subscriber template.
- For interpretation of the Gx rulebase (Charging-Rule-Base-Name AVP) from PCRF as ECS group-of-ruledefs, configure the following command in the Active Charging Service Configuration Mode:

```
policy-control charging-rule-base-name active-charging-group-of- ruledefs
```

Verifying the Subscriber Configuration

Verify the IMSA service configuration for subscriber(s) by entering the following command in the Exec CLI configuration mode:

```
show subscribers ims-auth-service <imsa_service_name>
```

Notes:

- <imsa_service_name> must be the name of the IMSA service configured for IMS authentication.

Gathering Statistics

This section explains how to gather Rel. 8 Gx statistics and configuration information.

In the following table, the first column lists what statistics to gather, and the second column lists the action to perform.

Table 56: Gathering HA/PDSN Rel. 8 Gx Statistics and Information

Statistics/Information	Action to perform
Information and statistics specific to policy control in IMS Authorization service.	show ims-authorization policy-control statistics

Statistics/Information	Action to perform
Information and statistics specific to the authorization servers used for IMS Authorization service.	show ims-authorization servers ims-auth-service
Information of all IMS Authorization service.	show ims-authorization service all
Statistics of IMS Authorization service.	show ims-authorization service statistics
Information, configuration, and statistics of sessions active in IMS Authorization service.	show ims-authorization sessions all
Complete information, configuration, and statistics of sessions active in IMS Authorization service.	show ims-authorization sessions full
Summarized information of sessions active in IMS Authorization service.	show ims-authorization sessions summary
Complete statistics for active charging service sessions.	show active-charging sessions full
Information for all rule definitions configured in the service.	show active-charging ruledef all
Information for all rulebases configured in the system.	show active-charging rulebase all
Information on all group of ruledefs configured in the system.	show active-charging group-of-ruledefs all

P-GW Rel. 8 Gx Interface Support

Introduction

The Gx reference point is located between the Policy and Charging Rules Function (PCRF) and the Policy and Charging Enforcement Function (PCEF) on the Packet Data Network (PDN) Gateway (P-GW). The Gx reference point is used for provisioning and removal of PCC rules from the PCRF to the PCEF and the transmission of traffic plane events from the PCEF to the PCRF. The Gx reference point can be used for charging control, policy control, or both, by applying AVPs relevant to the application.

The PCEF is the functional element that encompasses policy enforcement and flow based charging functionality. This functional entity is located at the P-GW. The main functions include:

- Control over the user plane traffic handling at the gateway and its QoS.
- Service data flow detection and counting, as well as online and offline charging interactions.
- For a service data flow that is under policy control, the PCEF allows the service data flow to pass through the gateway if and only if the corresponding gate is open.
- For a service data flow that is under charging control, the PCEF allows the service data flow to pass through the gateway if and only if there is a corresponding active PCC rule and, for online charging, the OCS has authorized the applicable credit with that charging key.
- If requested by the PCRF, the PCEF will report to the PCRF when the status of the related service data flow changes.

- In case the SDF is tunnelled at the BBERF, the PCEF informs the PCRF about the mobility protocol tunnelling header of the service data flows at IP-CAN session establishment.

Terminology and Definitions

This section describes features and terminology pertaining to Rel. 8 Gx functionality.

Volume Reporting Over Gx

This section describes the 3GPP Rel. 9 Volume Reporting over Gx feature.

License Requirements

The Volume Reporting over Gx is a licensed Cisco feature. A separate feature license may be required. Contact your Cisco account representative for detailed information on specific licensing requirements. For information on installing and verifying licenses, refer to the *Managing License Keys* section of the *Software Management Operations* chapter in the *System Administration Guide*.



Important No separate license is required for Charging over Gx / Volume Reporting over Gx feature. This feature can be enabled as part of "Policy Interface" license.

Supported Standards

The Volume Reporting over Gx feature is based on the following standard:

3GPP TS 29.212 V9.5.0 (2010-06): 3rd Generation Partnership Project; Technical Specification Group Core Network and Terminals; Policy and Charging Control over Gx reference point (Release 9).

Feature Overview

The Volume Reporting over Gx feature provides PCRF the capability to make real-time decisions based on the data usage by subscribers.



Important Volume Reporting over Gx is applicable only for volume quota.

Volume Reporting supports both the total data usage reporting and the uplink/downlink level reporting

The PCEF only reports the accumulated usage since the last report for usage monitoring and not from the beginning.

If the usage threshold is set to zero (infinite threshold), no further threshold events will be generated by PCEF, but monitoring of usage will continue and be reported at the end of the session.

It supports usage reporting on bearer termination.

The following steps explain how Volume Reporting over Gx works:

1. PCEF after receiving the message from PCRF parses the usage monitoring related AVPs, and sends the information to IMSA.
2. IMSA updates the information to ECS.

3. Once the ECS is updated with the usage monitoring information from PCRF, the PCEF (ECS) starts tracking the data usage.
4. For session-level monitoring, the ECS maintains the amount of data usage.
5. For PCC rule monitoring, usage is monitored with the monitoring key as the unique identifier. Each node maintains the usage information per monitoring key. When the data traffic is passed, the usage is checked against the usage threshold values and reported as described in the *Usage Reporting* section.
6. The PCEF continues to track data usage after the threshold is reached and before a new threshold is provided by the PCRF. If a new usage threshold is not provided by the PCRF in the acknowledgement of an IP-CAN Session modification where its usage was reported, then usage monitoring does not continue in the PCEF for that IP CAN session.

Usage Monitoring

- Usage Monitoring at Session Level: PCRF subscribes to the session-level volume reporting over Gx by sending the Usage-Monitoring-Information AVP with the usage threshold level set in Granted-Service-Unit AVP and Usage-Monitoring-Level AVP set to SESSION_LEVEL(0). After the AVPs are parsed by DPCA, IMSA updates the information to ECS. Once ECS is updated usage monitoring is started and constantly checked with the usage threshold whenever the data traffic is present. PCRF supports Monitoring Key at session level.

PCRF supports to enable and disable session usage in a single message. This is supported only if the monitoring key is associated at session level.

PCRF supports the monitoring of usage based on input/output octet threshold levels. Usage is reported based on the enabled threshold level. If multiple levels are enabled, usage will be reported on all the enabled levels even if only one of the levels is breached. Monitoring will be stopped on the missing threshold levels in the response for the usage report from PCRF (expected to provide the complete set again if PCRF wants to continue monitoring on the multiple levels enabled earlier).

Total threshold level along with UL/DL threshold level in the GSU AVP is treated as an error and only total threshold level is accepted.

Extra CCR-U was generated for a monitoring key when the following requests are received in the response to the CCR-U which reported the usage for the same monitoring key.

- immediate reporting request with monitoring key at rule level
- immediate reporting request with or without monitoring key at session level
- explicit disable request at rule level
- explicit disable request at session level

Extra CCR-U is not generated for a monitoring key when all the above mentioned requests are received in the response to the CCR-U which reported the usage for the same monitoring key. Also, extra CCR-U is not generated when immediate reporting request without monitoring key at rule level is received in the response to the CCR-U which reported the usage for all the active monitoring keys.

- Usage Monitoring at Flow Level: PCRF subscribes to the flow-level volume reporting over Gx by sending the Usage-Monitoring-Information AVP with the usage threshold level set in Granted-Service-Unit AVP and Usage-Monitoring-Level AVP set to PCC_RULE_LEVEL(1). Monitoring Key is mandatory in case of a flow-level monitoring since the rules are associated with the monitoring key and enabling/disabling of usage monitoring at flow level can be controlled by PCRF using it. After the AVPs are parsed by DPCA, IMSA updates the information to ECS. Once ECS is updated usage monitoring is started and constantly checked with the usage threshold whenever the data traffic is present.

Usage monitoring is supported for static, predefined rules, and dynamic rule definitions.

- **Usage Monitoring for Static Rules:** In the case of static rules, the usage reporting on last rule removal associated with the monitoring key is not applicable. In this case only the usage monitoring information is received from the PCRF.
- **Usage Monitoring for Predefined Rules:** If the usage monitoring needs to be enabled for the predefined rules, PCRF sends the rule and the usage monitoring information containing the monitoring key and the usage threshold. The Monitoring key should be same as the one pre-configured in PCEF for that predefined rule. There can be multiple rules associated with the same monitoring key. Hence enabling a particular monitoring key would result in the data being tracked for multiple rules having the same monitoring key. After DPCA parses the AVPs IMSA updates the information to ECS. Once ECS is updated usage monitoring is started and constantly checked with the usage threshold whenever the data traffic is present.
- **Usage Monitoring for Dynamic Rules:** If the usage monitoring needs to be enabled for dynamic ruledefs, PCRF provides the monitoring key along with a charging rule definition and the usage monitoring information containing the monitoring key and the usage threshold. This would result in the usage monitoring being done for all the rules associated with that monitoring key. After DPCA parses the AVPs, IMSA updates the information to ECS. Once ECS is updated, the usage monitoring is started and constantly checked with the usage threshold whenever the data traffic is present. Monitoring key for dynamic ruledef is dynamically assigned by PCRF which is the only difference with predefined rules in case of usage monitoring.

Only one of the monitoring keys' usage is reported first. Upon receiving successful response from PCRF, the rest of the monitoring keys' usage is reported to PCRF. On Tx expiry/TCP link error, unreported usage is stored at ECS. Any future successful interaction with PCRF for the session will send unreported UMI to PCRF.

Usage Reporting

Usage at subscriber/flow level is reported to PCRF under the following conditions:

- **Usage Threshold Reached:** PCEF records the subscriber data usage and checks if the usage threshold provided by PCRF is reached. This is done for both session and rule level reporting.

For session-level reporting, the actual usage volume is compared with the usage volume threshold.

For rule-level reporting the rule that hits the data traffic is used to find out if the monitoring key is associated with it, and based on the monitoring key the data usage is checked. Once the condition is met, it reports the usage information to IMSA and continues monitoring. IMSA then triggers the CCR-U if "USAGE_REPORT" trigger is enabled by the PCRF. The Usage-Monitoring-Information AVP is sent in this CCR with the "Used-Service-Unit" set to the amount of data usage by subscriber.

If PCRF does not provide a new usage threshold in the usage monitoring information as a result of CCR from PCEF when the usage threshold is reached, the usage monitoring is stopped at PCEF and no usage status is reported.

In the non-standard Volume Reporting over Gx implementation, usage monitoring will be stopped once the threshold is breached, else the monitoring will continue. There will be no further usage reporting until the CCA is received.

- **Usage Monitoring Disabled:** If the PCRF explicitly disables the usage monitoring with Usage-Monitoring-Support AVP set to USAGE_MONITORING_DISABLED, the PCEF stops monitoring and reports the usage information (when the monitoring was enabled) to PCRF if the usage monitoring

is disabled by PCRF as a result of CCR from PCEF which is not related to reporting usage, other external triggers, or a PCRF internal trigger. If the PCRF does not provide a new usage threshold as a result of CCR from PCEF when the usage threshold is reached, the usage monitoring is stopped at PCEF and no further usage status is reported.

- **IP CAN Session Termination:** When the IP CAN session is terminated, the accumulated subscriber usage information is reported to PCRF in the CCR-T from PCEF. If PCC usage level information is enabled by PCRF, the PCC usage will also be reported.

PCRF uses RAR message and includes Session-Release-Cause AVP in it to initiate IP CAN Session Termination. However, there are some scenarios where PCRF may want to terminate the IP CAN Session in CCA messages. In order to avoid an unnecessary additional message, PCRF can inform P-GW to terminate the subscriber in CCA-U message itself. Hence, the Session Release Cause has been added in CCA messages for all Gx dictionaries.

- **PCC Rule Removal:** When the PCRF deactivates the last PCC rule associated with a usage monitoring key, the PCEF sends a CCR with the data usage for that monitoring key. If the PCEF reports the last PCC rule associated with a usage monitoring key is inactive, the PCEF reports the accumulated usage for that monitoring key within the same CCR command if the Charging-Rule-Report AVP was included in a CCR command; otherwise, if the Charging-Rule-Report AVP was included in an RAA command, the PCEF sends a new CCR command to report accumulated usage for the usage monitoring key. Usage reporting on last rule deactivation using rule deactivation time set by PCRF is supported.

On receiving message from PCRF, the rule that is meant for removal is marked and then after the access side procedure is complete the rule is removed.

- **PCRF Requested Usage Report:** The accumulated usage since the last report is sent even in case of immediate reporting, the usage is reset after immediate reporting and usage monitoring continued so that the subsequent usage report will have the usage since the current report.
- **The usage reporting on bearer termination can be added.** When a bearer is deleted due to some reason, the rules associated with the bearer will also be removed. So, the usage will be reported on the monitoring key(s) whose associated rule is the last one that is removed because of bearer termination.
- **Revalidation Timeout:** In the non-standard implementation, if usage monitoring and reporting is enabled and a revalidation timeout occurs, the PCEF sends a CCR to request PCC rules and reports all accumulated usage for all enabled monitoring keys since the last report (or since usage reporting was enabled if the usage was not yet reported) with the accumulated usage at IP-CAN session level (if enabled) and at service data flow level (if enabled) This is the default behavior.

In the case of standard implementation, this must be enabled by CLI configuration.



Important The Usage Reporting on Revalidation Timeout feature is available by default in non-standard implementation of Volume Reporting over Gx. This is configurable in the standard implementation.

Once the usage is reported, the usage counter is reset to zero. The PCEF continues to track data usage from the zero value after the threshold is reached and before a new threshold is provided by the PCRF. If a new usage threshold is not provided by the PCRF in the acknowledgement of an IP-CAN Session modification where its usage was reported, then usage monitoring does not continue in the PCEF for that IP CAN session and the usage accumulated between the CCR-CCA will be discarded.

CCR-U triggered on server retries takes server granted quota into account for reporting USU. For newly created MSCC, interim quota configuration is taken as reference for reporting USU.

For information on how to configure the Volume Reporting over Gx feature, refer to [Configuring Volume Reporting over Gx](#), on page 523.

ICSR Support for Volume Reporting over Gx (VoRoGx)

Volume threshold and volume usage are synced to standby chassis to support volume reporting over Gx for existing sessions post ICSR switchover.

Without this support it cannot cause a subscriber to use higher speeds than what s/he is supposed to get, if volume reporting is for example used to enforce fair usage; the operator may already consider this a revenue loss. It will also severely impact roaming subscribers who are supposed to get a notification and be blocked/redirected once the limits set by the EU roaming regulation are reached. If a session continues now without being blocked, the operator is not allowed to charge for data beyond the limit and will have a significant and real revenue loss (roaming partner may still charge for the data used on their SGSNs).

Rel. 9 Gx Interface

Rel. 9 Gx interface support is available on the Cisco ASR chassis.

P-GW Rel. 9 Gx Interface Support

Introduction

The Gx reference point is located between the Policy and Charging Rules Function (PCRF) and the Policy and Charging Enforcement Function (PCEF) on the Packet Data Network (PDN) Gateway (P-GW). The Gx reference point is used for provisioning and removal of PCC rules from the PCRF to the PCEF and the transmission of traffic plane events from the PCEF to the PCRF. The Gx reference point can be used for charging control, policy control, or both, by applying AVPs relevant to the application.

The PCEF is the functional element that encompasses policy enforcement and flow based charging functionality. This functional entity is located at the P-GW. The main functions include:

- Control over the user plane traffic handling at the gateway and its QoS.
- Service data flow detection and counting, as well as online and offline charging interactions.
- For a service data flow that is under policy control, the PCEF allows the service data flow to pass through the gateway if and only if the corresponding gate is open.
- For a service data flow that is under charging control, the PCEF allows the service data flow to pass through the gateway if and only if there is a corresponding active PCC rule and, for online charging, the OCS has authorized the applicable credit with that charging key.
- If requested by the PCRF, the PCEF reports to the PCRF when the status of the related service data flow changes.
- In case the SDF is tunnelled at the BBERF, the PCEF informs the PCRF about the mobility protocol tunnelling header of the service data flows at IP-CAN session establishment.



Important

ASR 5500 supports only eight flow information including the flow description per dynamic charging rule in a Gx message.

Terminology and Definitions

This section describes features and terminology pertaining to Rel. 9 Gx functionality.

Volume Reporting Over Gx

This section describes the 3GPP Rel. 9 Volume Reporting over Gx feature.

License Requirements

The Volume Reporting over Gx is a licensed Cisco feature. A separate feature license may be required. Contact your Cisco account representative for detailed information on specific licensing requirements. For information on installing and verifying licenses, refer to the *Managing License Keys* section of the *Software Management Operations* chapter in the *System Administration Guide*.



Important

No separate license is required for Charging over Gx / Volume Reporting over Gx feature. This feature can be enabled as part of "Policy Interface" license.

Supported Standards

The Volume Reporting over Gx feature is based on the following standard:

3GPP TS 29.212 V9.5.0 (2011-01): 3rd Generation Partnership Project; Technical Specification Group Core Network and Terminals; Policy and Charging Control over Gx reference point (Release 9).

Feature Overview

The Volume Reporting over Gx feature provides PCRF the capability to make real-time decisions based on the data usage by subscribers.



Important

Volume Reporting over Gx is applicable only for volume quota.

Volume Reporting over GX supports both the total data usage reporting and uplink/downlink level reporting.

The PCEF only reports the accumulated usage since the last report for usage monitoring and not from the beginning.

If the usage threshold is set to zero (infinite threshold), no further threshold events will be generated by PCEF, but monitoring of usage will continue and be reported at the end of the session.

The usage reporting on bearer termination is supported.

The following steps explain how Volume Reporting over Gx works:

1. PCEF after receiving the message from PCRF parses the usage monitoring related AVPs, and sends the information to IMSA.
2. IMSA updates the information to ECS.
3. Once the ECS is updated with the usage monitoring information from PCRF, the PCEF (ECS) starts tracking the data usage.
4. For session-level monitoring, the ECS maintains the amount of data usage.

5. For PCC rule monitoring, usage is monitored with the monitoring key as the unique identifier. Each node maintains the usage information per monitoring key. When the data traffic is passed, the usage is checked against the usage threshold values and reported as described in the *Usage Reporting* section.
6. The PCEF continues to track data usage after the threshold is reached and before a new threshold is provided by the PCRF. If a new usage threshold is not provided by the PCRF in the acknowledgement of an IP-CAN Session modification where its usage was reported, then usage monitoring does not continue in the PCEF for that IP CAN session.

Usage Monitoring

- Usage Monitoring at Session Level: PCRF subscribes to the session-level volume reporting over Gx by sending the Usage-Monitoring-Information AVP with the usage threshold level set in Granted-Service-Unit AVP and Usage-Monitoring-Level AVP set to SESSION_LEVEL(0). After the AVPs are parsed by DPCA, IMSA updates the information to ECS. Once ECS is updated usage monitoring is started and constantly checked with the usage threshold whenever the data traffic is present. PCRF supports Monitoring Key at session level.

PCRF supports to enable and disable session usage in a single message. This is supported only if the monitoring key is associated at session level.

PCRF supports the monitoring of usage based on input/output octet threshold levels. Usage is reported based on the enabled threshold level. If multiple levels are enabled, usage will be reported on all the enabled levels even if only one of the levels is breached. Monitoring will be stopped on the missing threshold levels in the response for the usage report from PCRF (expected to provide the complete set again if PCRF wants to continue monitoring on the multiple levels enabled earlier).

Total threshold level along with UL/DL threshold level in the GSU AVP is treated as an error and only total threshold level is accepted.

An extra CCR-U was generated for a monitoring key when the following requests are received in the response to the CCR-U which reported the usage for the same monitoring key.

- immediate reporting request with monitoring key at rule level
- immediate reporting request with or without monitoring key at session level
- explicit disable request at rule level
- explicit disable request at session level

An extra CCR-U is not generated for a monitoring key when all the above mentioned requests are received in the response to the CCR-U which reported the usage for the same monitoring key. Also, extra CCR-U is not generated when immediate reporting request without monitoring key at rule level is received in the response to the CCR-U which reported the usage for all the active monitoring keys.

- Usage Monitoring at Flow Level: PCRF subscribes to the flow-level volume reporting over Gx by sending the Usage-Monitoring-Information AVP with the usage threshold level set in Granted-Service-Unit AVP and Usage-Monitoring-Level AVP set to PCC_RULE_LEVEL(1). Monitoring Key is mandatory in case of a flow-level monitoring since the rules are associated with the monitoring key and enabling/disabling of usage monitoring at flow level can be controlled by PCRF using it. After the AVPs are parsed by DPCA, IMSA updates the information to ECS. Once ECS is updated usage monitoring is started and constantly checked with the usage threshold whenever the data traffic is present.

Usage monitoring is supported for static, predefined rules, and dynamic rule definitions.

- Usage Monitoring for Static Rules: In the case of static rules, the usage reporting on last rule removal associated with the monitoring key is not applicable. In this case only the usage monitoring information is received from the PCRF.

- **Usage Monitoring for Predefined Rules:** If the usage monitoring needs to be enabled for the predefined rules, PCRF sends the rule and the usage monitoring information containing the monitoring key and the usage threshold. The Monitoring key should be same as the one pre-configured in PCEF for that predefined rule. There can be multiple rules associated with the same monitoring key. Hence enabling a particular monitoring key would result in the data being tracked for multiple rules having the same monitoring key. After DPCA parses the AVPs IMSA updates the information to ECS. Once ECS is updated usage monitoring is started and constantly checked with the usage threshold whenever the data traffic is present.
- **Usage Monitoring for Dynamic Rules:** If the usage monitoring needs to be enabled for dynamic ruledefs, PCRF provides the monitoring key along with a charging rule definition and the usage monitoring information containing the monitoring key and the usage threshold. This would result in the usage monitoring being done for all the rules associated with that monitoring key. After DPCA parses the AVPs, IMSA updates the information to ECS. Once ECS is updated, the usage monitoring is started and constantly checked with the usage threshold whenever the data traffic is present. Monitoring key for dynamic ruledef is dynamically assigned by PCRF which is the only difference with predefined rules in case of usage monitoring.

Only one of the monitoring keys' usage is reported first. Upon receiving successful response from PCRF, the rest of the monitoring keys' usage is reported to PCRF. On Tx expiry/TCP link error, unreported usage is stored at ECS. Any future successful interaction with PCRF for the session will send unreported UMI to PCRF.

Usage Reporting

Usage at subscriber/flow level is reported to PCRF under the following conditions:

- **Usage Threshold Reached:** PCEF records the subscriber data usage and checks if the usage threshold provided by PCRF is reached. This is done for both session and rule level reporting.

For session-level reporting, the actual usage volume is compared with the usage volume threshold.

For rule-level reporting the rule that hits the data traffic is used to find out if the monitoring key is associated with it, and based on the monitoring key the data usage is checked. Once the condition is met, it reports the usage information to IMSA and continues monitoring. IMSA then triggers the CCR-U if "USAGE_REPORT" trigger is enabled by the PCRF. The Usage-Monitoring-Information AVP is sent in this CCR with the "Used-Service-Unit" set to the amount of data usage by subscriber.

If PCRF does not provide a new usage threshold in the usage monitoring information as a result of CCR from PCEF when the usage threshold is reached, the usage monitoring is stopped at PCEF and no usage status is reported.

In the non-standard Volume Reporting over Gx implementation, usage monitoring will be stopped once the threshold is breached, else the monitoring will continue. There will be no further usage reporting until the CCA is received.

- **Usage Monitoring Disabled:** If the PCRF explicitly disables the usage monitoring with Usage-Monitoring-Support AVP set to USAGE_MONITORING_DISABLED, the PCEF stops monitoring and reports the usage information (when the monitoring was enabled) to PCRF if the usage monitoring is disabled by PCRF as a result of CCR from PCEF which is not related to reporting usage, other external triggers, or a PCRF internal trigger. If the PCRF does not provide a new usage threshold as a result of CCR from PCEF when the usage threshold is reached, the usage monitoring is stopped at PCEF and no further usage status is reported.

- **IP CAN Session Termination:** When the IP CAN session is terminated, the accumulated subscriber usage information is reported to PCRF in the CCR-T from PCEF. If PCC usage level information is enabled by PCRF, the PCC usage will also be reported.

PCRF uses RAR message and includes Session-Release-Cause AVP in it to initiate IP CAN Session Termination. However, there are some scenarios where PCRF may want to terminate the IP CAN Session in CCA messages. In order to avoid an unnecessary additional message, PCRF can inform P-GW to terminate the subscriber in CCA-U message itself. Hence, the Session Release Cause has been added in CCA messages for all Gx dictionaries.

- **PCC Rule Removal:** When the PCRF deactivates the last PCC rule associated with a usage monitoring key, the PCEF sends a CCR with the data usage for that monitoring key. If the PCEF reports the last PCC rule associated with a usage monitoring key is inactive, the PCEF reports the accumulated usage for that monitoring key within the same CCR command if the Charging-Rule-Report AVP was included in a CCR command; otherwise, if the Charging-Rule-Report AVP was included in an RAA command, the PCEF sends a new CCR command to report accumulated usage for the usage monitoring key. Usage reporting on last rule deactivation using rule deactivation time set by PCRF is supported.

On receiving message from PCRF, the rule that is meant for removal is marked and then after the access side procedure is complete the rule is removed.

- **PCRF Requested Usage Report:** The accumulated usage since the last report is sent even in case of immediate reporting, the usage is reset after immediate reporting and usage monitoring continued so that the subsequent usage report will have the usage since the current report.
- **The usage reporting on bearer termination can be added.** When a bearer is deleted due to some reason, the rules associated with the bearer will also be removed. So, the usage will be reported on the monitoring key(s) whose associated rule is the last one that is removed because of bearer termination.
- **Revalidation Timeout:** In the non-standard implementation, if usage monitoring and reporting is enabled and a revalidation timeout occurs, the PCEF sends a CCR to request PCC rules and reports all accumulated usage for all enabled monitoring keys since the last report (or since usage reporting was enabled if the usage was not yet reported) with the accumulated usage at IP-CAN session level (if enabled) and at service data flow level (if enabled) This is the default behavior.

In the case of standard implementation, this must be enabled by CLI configuration.



Important The Usage Reporting on Revalidation Timeout feature is available by default in non-standard implementation of Volume Reporting over Gx. This is configurable in the standard implementation.

Once the usage is reported, the usage counter is reset to zero. The PCEF continues to track data usage from the zero value after the threshold is reached and before a new threshold is provided by the PCRF. If a new usage threshold is not provided by the PCRF in the acknowledgement of an IP-CAN Session modification where its usage was reported, then usage monitoring does not continue in the PCEF for that IP CAN session and the usage accumulated between the CCR-CCA will be discarded.

CCR-U triggered on server retries takes server granted quota into account for reporting USU. For newly created MSCC, interim quota configuration is taken as reference for reporting USU.

For information on how to configure the Volume Reporting over Gx feature, see the [Configuring Volume Reporting over Gx, on page 523](#) section.

ICSR Support for Volume Reporting over Gx (VoRoGx)

Volume threshold and volume usage are synced to standby chassis to support volume reporting over Gx for existing sessions post ICSR switchover.

Without this support it cannot cause a subscriber to use higher speeds than what s/he is supposed to get, if volume reporting is for example used to enforce fair usage; the operator may already consider this a revenue loss. It will also severely impact roaming subscribers who are supposed to get a notification and be blocked/redirected once the limits set by the EU roaming regulation are reached. If a session continues now without being blocked, the operator is not allowed to charge for data beyond the limit and will have a significant and real revenue loss (roaming partner may still charge for the data used on their SGSNs).

3GPP Rel.9 Compliance for IPFilterRule

This section describes the overview and implementation of 3GPP Rel.9 Compliance for IPFilterRule feature.

This section discusses the following topics for this feature:

- [Feature Description, on page 550](#)
- [Configuring Rel.9 Compliant AVPs, on page 551](#)
- [Monitoring and Troubleshooting the 3GPP Rel.9 Compliance for IPFilterRule, on page 552](#)

Feature Description

Currently, PCEF is 3GPP Rel. 8 compliant for IPFilterRule in Flow-Description AVP, TFT-Filter, and Packet-Filter-Content AVPs. When PCRF sends the CCA-U or RAR with Flow-Description AVP in Rel. 9 format during a network initiated dedicated bearer creation or modification, PCEF was misinterpreting the source and destination IP address, resulting in sending a wrong TFT to UE.

When the PCRF is upgraded to 3GPP Rel. 9, PCEF still sends CCR-U with Flow-Description, TFT-Filter and Packet-Filter-Content AVPs in Rel. 8 format during UE initiated secondary bearer creation or modification.

To make the PCEF 3GPP Rel. 9 compliant for Flow-Description AVP, TFT-Filter, and Packet-Filter-Content AVPs, the following changes are implemented:

- Interpretation of the source and destination IP address in IPFilterRule in Flow-Description AVP is changed to maintain 3GPP Rel.9 compliancy. That is, when a Rel. 9 Flow-Description for UPLINK is received during a network-initiated bearer creation or modification, the source IP address is interpreted as remote and the destination as local IP address.
- Traffic flow direction is interpreted from a new Diameter AVP "Flow-Direction". This new AVP indicates the direction or directions that a filter is applicable, downlink only, uplink only or both downlink and uplink (bi-directional).
- IMSA module is modified to encode TFT-Packet-Filter-Information and Packet-Filter-Information AVPs in Rel. 9 format if the negotiated supported feature is Rel. 9 and above.
- Configuration support is provided to enable Rel.9 changes for Flow-Description, TFT-Filter, and Packet-Filter-Content AVPs sent by PCEF in CCR-U. The **diameter 3gpp-r9-flow-direction** CLI command is used to enable Rel. 9 changes. When this CLI command is configured and negotiated supported feature is Rel. 9 or above (both gateway and PCRF are Rel. 9+ compliant), P-GW sends Flow-Description, TFT-Filter, and Packet-Filter-Content AVPs in Rel. 9 format.

Backward compatibility is maintained, i.e. both Rel. 8 (permit in/out) and Rel. 9 (permit out with flow-direction) formats are accepted by PCEF.

Per the 3GPP Rel. 8 standards, the IPFilterRule in Flow-Description, TFT-Filter, and Packet-Filter-Content AVPs is sent as "permit in" for UPLINK and "permit out" for DOWNLINK direction. From 3GPP Rel. 9 onwards, the Flow-Description AVP within the Flow-Information AVP will have only "permit out" and the traffic flow direction is indicated through Flow-Direction AVP. In 3GPP Rel. 9 format, both UPLINK and DOWNLINK are always sent as "permit out" and hence the usage of "permit in" is deprecated.



Important This feature is applicable for 3GPP Rel. 9 compliant PCEF and PCRF only when the supported feature negotiated in CCA-I is Rel. 9 or above through the **diameter update-dictionary-avps { 3gpp-r9 | 3gpp-r10 }** CLI command.

Relationships to Other Features

This feature works only when the **diameter update-dictionary-avps** CLI command is configured as 3gpp-r9 or 3gpp-r10. That is, PCEF will send Flow-Description, TFT-Filter, and Packet-Filter-Content AVPs in 3GPP Rel. 9 format only when **diameter 3gpp-r9-flow-direction** CLI command is enabled and negotiated supported feature is Rel. 9 or above. The **diameter 3gpp-r9-flow-direction** CLI command for activating this feature must be used only after the PCRF is upgraded to Rel. 9.

Configuring Rel.9 Compliant AVPs

The following section provides the configuration commands to enable Rel.9 changes for Flow-Description, TFT-Filter, and Packet-Filter-Content AVPs.

Encoding AVPs for 3GPP Compliance

Use the following configuration commands to control PCEF from sending Flow-Description, TFT-Filter, and Packet-Filter-Content AVPs in Rel. 9 format.

```
configure
  context context_name
    ims-auth-service service_name
      policy-control
        diameter 3gpp-r9-flow-direction
end
```

- **3gpp-r9-flow-direction**: Encodes Flow-Direction, Flow-Description, TFT-Filter, and Packet-Filter-Content AVPs based on 3GPP Rel. 9 specification. By default, this feature is disabled.
- This CLI configuration is applicable only for TFT-Filter, Packet-Filter-Content, and Flow-Description AVPs sent by PCEF in CCR-U.
- This CLI command must be used only after the PCRF is upgraded to Rel. 9.
- This CLI command works in conjunction with **diameter update-dictionary-avps { 3gpp-r9 | 3gpp-r10 }**. When **diameter 3gpp-r9-flow-direction** is configured and negotiated supported feature is 3gpp-r9 or above, PCEF will send Flow-Description, TFT-Filter, and Packet-Filter-Content AVPs in 3GPP Rel. 9 format.

Verifying the Configuration for AVP Compliance

Use the following command to verify the configuration status of this feature.

```
show ims-authorization service name service_name
```

service_name must be the name of the IMS Authorization service configured for IMS authentication.

The "3GPP R9 Flow Direction Compliance" field can be used to determine whether this feature is enabled or disabled.

```
[local]st40# show ims-authorization service name gngp-gx
Context: gngp
IMS Authorization Service name: gngp-gx
Service State: Enabled
Service Mode: Single Interface Policy and Charging
...
Diameter Policy Control:
Endpoint: gx
Origin-Realm: xyz.com
Dictionary: r8-gx-standard
Supported Features:
    3gpp-r9
...
Host Selection: Table: 1 Algorithm: Round-Robin
Host Reselection Subscriber Limit: Not Enabled
Host Reselection Interval: Not Enabled
Sgsn Change Reporting: Not Enabled
    3GPP R9 Flow Direction Compliance: Enabled
Host Selection Table[1]: 1 Row(s)
Precedence: 1
...
```

Monitoring and Troubleshooting the 3GPP Rel.9 Compliance for IPFilterRule

This section provides information regarding show commands and/or their outputs in support of this feature.

The following operations should be performed for any failure related to this feature:

- Verify if the feature is enabled using **show ims-authorization service name** <*service_name*> CLI command. If not enabled, configure the **diameter 3gpp-r9-flow-direction** CLI command and check if it works.
- Execute **monitor protocol** command, and check if supported feature negotiated in CCA-I is Rel. 9 or above. If not, this feature will not work. Set the supported feature using **diameter update-dictionary-avps { 3gpp-r9 | 3gpp-r10 }** CLI command.
- If the failure is still observed, obtain the following information and contact Cisco account representative for further analysis:
 - monitor protocol log with options 24 (GTPC) and 75-3 (App Specific Diameter - DIAMETER Gx/Ty/Gxx) turned on
 - logs with acsmgr enabled
 - Output of **show active-charging sessions full all** and show ims-authorization sessions CLI commands

show ims-authorization service name

A new field "3GPP R9 Flow Direction Compliance" is added to the output of this show command to indicate whether the Rel. 9 Flow-Direction change is enabled or disabled.

Rel. 10 Gx Interface

Rel. 10 Gx interface support is available on the Cisco ASR chassis.

This section describes the following topic:

- [P-GW Rel. 10 Gx Interface Support, on page 553](#)

P-GW Rel. 10 Gx Interface Support

Introduction

The Gx reference point is located between the Policy and Charging Rules Function (PCRF) and the Policy and Charging Enforcement Function (PCEF) on the Packet Data Network (PDN) Gateway (P-GW). The Gx reference point is used for provisioning and removal of PCC rules from the PCRF to the PCEF and the transmission of traffic plane events from the PCEF to the PCRF. The Gx reference point can be used for charging control, policy control, or both, by applying AVPs relevant to the application.

The PCEF is the functional element that encompasses policy enforcement and flow based charging functionality. This functional entity is located at the P-GW. The main functions include:

- Control over the user plane traffic handling at the gateway and its QoS.
- Service data flow detection and counting, as well as online and offline charging interactions.
- For a service data flow that is under policy control, the PCEF allows the service data flow to pass through the gateway if and only if the corresponding gate is open.
- For a service data flow that is under charging control, the PCEF allows the service data flow to pass through the gateway if and only if there is a corresponding active PCC rule and, for online charging, the OCS has authorized the applicable credit with that charging key.
- If requested by the PCRF, the PCEF will report to the PCRF when the status of the related service data flow changes.
- In case the SDF is tunnelled at the BBERF, the PCEF informs the PCRF about the mobility protocol tunnelling header of the service data flows at IP-CAN session establishment.



Important

ASR 5500 supports only eight flow information including the flow description per dynamic charging rule in a Gx message.

Terminology and Definitions

This section describes features and terminology pertaining to Rel. 10 Gx functionality.

Volume Reporting Over Gx

This section describes the 3GPP Rel. 10 Volume Reporting over Gx feature.

License Requirements

The Volume Reporting over Gx is a licensed Cisco feature. A separate feature license may be required. Contact your Cisco account representative for detailed information on specific licensing requirements. For information on installing and verifying licenses, refer to the *Managing License Keys* section of the *Software Management Operations* chapter in the *System Administration Guide*.



Important No separate license is required for Charging over Gx / Volume Reporting over Gx feature. This feature can be enabled as part of "Policy Interface" license.

Supported Standards

The Volume Reporting over Gx feature is based on the following standard:

3GPP TS 29.212 V10.5.0 (2012-01): 3rd Generation Partnership Project; Technical Specification Group Core Network and Terminals; Policy and Charging Control over Gx reference point (Release 10).

Feature Overview

The Volume Reporting over Gx feature provides PCRF the capability to make real-time decisions based on the data usage by subscribers.



Important Volume Reporting over Gx is applicable only for volume quota.

The PCEF only reports the accumulated usage since the last report for usage monitoring and not from the beginning.

If the usage threshold is set to zero (infinite threshold), no further threshold events will be generated by PCEF, but monitoring of usage will continue and be reported at the end of the session.

The usage reporting on bearer termination is supported.

The following steps explain how Volume Reporting over Gx works:

1. PCEF after receiving the message from PCRF parses the usage monitoring related AVPs, and sends the information to IMSA.
2. IMSA updates the information to ECS.
3. Once the ECS is updated with the usage monitoring information from PCRF, the PCEF (ECS) starts tracking the data usage.
4. For session-level monitoring, the ECS maintains the amount of data usage.
5. For PCC rule monitoring, usage is monitored with the monitoring key as the unique identifier. Each node maintains the usage information per monitoring key. When the data traffic is passed, the usage is checked against the usage threshold values and reported as described in the *Usage Reporting* section.
6. The PCEF continues to track data usage after the threshold is reached and before a new threshold is provided by the PCRF. If a new usage threshold is not provided by the PCRF in the acknowledgement of an IP-CAN Session modification where its usage was reported, then usage monitoring does not continue in the PCEF for that IP CAN session.

Usage Monitoring

- Usage Monitoring at Session Level: PCRF subscribes to the session-level volume reporting over Gx by sending the Usage-Monitoring-Information AVP with the usage threshold level set in Granted-Service-Unit AVP and Usage-Monitoring-Level AVP set to SESSION_LEVEL(0). After the AVPs are parsed by DPCA, IMSA updates the information to ECS. Once ECS is updated usage monitoring is started and constantly checked with the usage threshold whenever the data traffic is present. PCRF supports the Monitoring Key at session level.

PCRF supports to enable and disable session usage in a single message. This is supported only if the monitoring key is associated at session level.

PCRF supports the monitoring of usage based on input/output octet threshold levels. Usage is reported based on the enabled threshold level. If multiple levels are enabled, usage will be reported on all the enabled levels even if only one of the levels is breached. Monitoring will be stopped on the missing threshold levels in the response for the usage report from PCRF (expected to provide the complete set again if PCRF wants to continue monitoring on the multiple levels enabled earlier).

Total threshold level along with UL/DL threshold level in the GSU AVP is treated as an error and only total threshold level is accepted.

An extra CCR-U was generated for a monitoring key when the following requests are received in the response to the CCR-U which reported the usage for the same monitoring key.

- immediate reporting request with monitoring key at rule level
- immediate reporting request with or without monitoring key at session level
- explicit disable request at rule level
- explicit disable request at session level

An extra CCR-U is not generated for a monitoring key when all the above mentioned requests are received in the response to the CCR-U which reported the usage for the same monitoring key. Also, extra CCR-U is not generated when immediate reporting request without monitoring key at rule level is received in the response to the CCR-U which reported the usage for all the active monitoring keys.

- Usage Monitoring at Flow Level: PCRF subscribes to the flow-level volume reporting over Gx by sending the Usage-Monitoring-Information AVP with the usage threshold level set in Granted-Service-Unit AVP and Usage-Monitoring-Level AVP set to PCC_RULE_LEVEL(1). Monitoring Key is mandatory in case of a flow-level monitoring since the rules are associated with the monitoring key and enabling/disabling of usage monitoring at flow level can be controlled by PCRF using it. After the AVPs are parsed by DPCA, IMSA updates the information to ECS. Once ECS is updated usage monitoring is started and constantly checked with the usage threshold whenever the data traffic is present.

Usage monitoring is supported for static, predefined rules, and dynamic rule definitions.

- Usage Monitoring for Static Rules: In the case of static rules, the usage reporting on last rule removal associated with the monitoring key is not applicable. In this case only the usage monitoring information is received from the PCRF.
- Usage Monitoring for Predefined Rules: If the usage monitoring needs to be enabled for the predefined rules, PCRF sends the rule and the usage monitoring information containing the monitoring key and the usage threshold. The Monitoring key should be same as the one pre-configured in PCEF for that predefined rule. There can be multiple rules associated with the same monitoring key. Hence enabling a particular monitoring key would result in the data being tracked for multiple rules having the same monitoring key. After DPCA parses the AVPs IMSA updates the information to ECS. Once ECS is updated usage monitoring is started and constantly checked with the usage threshold whenever the data traffic is present.

- Usage Monitoring for Dynamic Rules: If the usage monitoring needs to be enabled for dynamic ruledefs, PCRF provides the monitoring key along with a charging rule definition and the usage monitoring information containing the monitoring key and the usage threshold. This would result in the usage monitoring being done for all the rules associated with that monitoring key. After DPCA parses the AVPs, IMSA updates the information to ECS. Once ECS is updated, the usage monitoring is started and constantly checked with the usage threshold whenever the data traffic is present. Monitoring key for dynamic ruledef is dynamically assigned by PCRF which is the only difference with predefined rules in case of usage monitoring.

When threshold breach happens for multiple monitoring keys at the same time, only one of the monitoring keys' usage is reported first. Upon receiving successful response from PCRF, the rest of the monitoring keys' usage is reported to PCRF. On Tx expiry/TCP link error, unreported usage is stored at ECS. Any future successful interaction with PCRF for the session will send unreported UMI to PCRF.

Usage Reporting

Usage at subscriber/flow level is reported to PCRF under the following conditions:

- Usage Threshold Reached: PCEF records the subscriber data usage and checks if the usage threshold provided by PCRF is reached. This is done for both session and rule level reporting.

For session-level reporting, the actual usage volume is compared with the usage volume threshold.

For rule-level reporting the rule that hits the data traffic is used to find out if the monitoring key is associated with it, and based on the monitoring key the data usage is checked. Once the condition is met, it reports the usage information to IMSA and continues monitoring. IMSA then triggers the CCR-U if "USAGE_REPORT" trigger is enabled by the PCRF. The Usage-Monitoring-Information AVP is sent in this CCR with the "Used-Service-Unit" set to the amount of data usage by subscriber.

If PCRF does not provide a new usage threshold in the usage monitoring information as a result of CCR from PCEF when the usage threshold is reached, the usage monitoring is stopped at PCEF and no usage status is reported.

In the non-standard Volume Reporting over Gx implementation, usage monitoring will be stopped once the threshold is breached, else the monitoring will continue. There will be no further usage reporting until the CCA is received.

- Usage Monitoring Disabled: If the PCRF explicitly disables the usage monitoring with Usage-Monitoring-Support AVP set to USAGE_MONITORING_DISABLED, the PCEF stops monitoring and reports the usage information (when the monitoring was enabled) to PCRF if the usage monitoring is disabled by PCRF as a result of CCR from PCEF which is not related to reporting usage, other external triggers, or a PCRF internal trigger. If the PCRF does not provide a new usage threshold as a result of CCR from PCEF when the usage threshold is reached, the usage monitoring is stopped at PCEF and no further usage status is reported.
- IP CAN Session Termination: When the IP CAN session is terminated, the accumulated subscriber usage information is reported to PCRF in the CCR-T from PCEF. If PCC usage level information is enabled by PCRF, the PCC usage will also be reported.

PCRF uses RAR message and includes Session-Release-Cause AVP in it to initiate IP CAN Session Termination. However, there are some scenarios where PCRF may want to terminate the IP CAN Session in CCA messages. In order to avoid an unnecessary additional message, PCRF can inform P-GW to terminate the subscriber in CCA-U message itself. Hence, the Session Release Cause has been added in CCA messages for all Gx dictionaries.

- **PCC Rule Removal:** When the PCRF deactivates the last PCC rule associated with a usage monitoring key, the PCEF sends a CCR with the data usage for that monitoring key. If the PCEF reports the last PCC rule associated with a usage monitoring key is inactive, the PCEF reports the accumulated usage for that monitoring key within the same CCR command if the Charging-Rule-Report AVP was included in a CCR command; otherwise, if the Charging-Rule-Report AVP was included in an RAA command, the PCEF sends a new CCR command to report accumulated usage for the usage monitoring key. The usage reporting on last rule deactivation using rule deactivation time set by PCRF is supported.

On receiving message from PCRF, the rule that is meant for removal is marked and then after the access side procedure is complete the rule is removed.

- **PCRF Requested Usage Report:** The accumulated usage since the last report is sent even in case of immediate reporting, the usage is reset after immediate reporting and usage monitoring continued so that the subsequent usage report will have the usage since the current report.
- **The usage reporting on bearer termination can be added.** When a bearer is deleted due to some reason, the rules associated with the bearer will also be removed. So, the usage will be reported on the monitoring key(s) whose associated rule is the last one that is removed because of bearer termination.
- **Revalidation Timeout:** In the non-standard implementation, if usage monitoring and reporting is enabled and a revalidation timeout occurs, the PCEF sends a CCR to request PCC rules and reports all accumulated usage for all enabled monitoring keys since the last report (or since usage reporting was enabled if the usage was not yet reported) with the accumulated usage at IP-CAN session level (if enabled) and at service data flow level (if enabled) This is the default behavior.

In the case of standard implementation, this must be enabled by CLI configuration.



Important The Usage Reporting on Revalidation Timeout feature is available by default in non-standard implementation of Volume Reporting over Gx. This is configurable in the standard implementation.

Once the usage is reported, the usage counter is reset to zero. The PCEF continues to track data usage from the zero value after the threshold is reached and before a new threshold is provided by the PCRF. If a new usage threshold is not provided by the PCRF in the acknowledgement of an IP-CAN Session modification where its usage was reported, then usage monitoring does not continue in the PCEF for that IP CAN session and the usage accumulated between the CCR-CCA will be discarded.

CCR-U triggered on server retries takes server granted quota into account for reporting USU. For newly created MSCC, interim quota configuration is taken as reference for reporting USU.

For information on how to configure the Volume Reporting over Gx feature, refer to [Configuring Volume Reporting over Gx, on page 523](#).

ICSR Support for Volume Reporting over Gx (VoRoGx)

Volume threshold and volume usage are synced to standby chassis to support volume reporting over Gx for existing sessions post switchover.

Without this support it cannot cause a subscriber to use higher speeds than what s/he is supposed to get, if volume reporting is for example used to enforce fair usage; the operator may already consider this a revenue loss. It will also severely impact roaming subscribers who are supposed to get a notification and be blocked/redirected once the limits set by the EU roaming regulation are reached. If a session continues now without being blocked, the operator is not allowed to charge for data beyond the limit and will have a significant and real revenue loss (roaming partner may still charge for the data used on their SGSNs).

Use of the Supported-Features AVP on the Gx Interface

The Supported-Features AVP is used during session establishment to inform the destination host about the required and optional features that the origin host supports. The client will, in the first request in a Diameter session indicate the set of features required for the successful processing of the session. If there are features supported by the client that are not advertised as part of the required set of features, the client will provide in the same request this set of optional features that are optional for the successful processing of the session. The server will, in the first answer within the Diameter session indicate the set of features that it has in common with the client and that the server will support within the same Diameter session. Any further command messages will always be compliant with the list of supported features indicated in the Supported-Features AVPs and features that are not indicated in the Supported-Features AVPs during session establishment. Features that are not advertised as supported will not be used to construct the command messages for that Diameter session. Unless otherwise stated, the use of the Supported-Features AVP on the Gx reference point will be compliant with the requirements for dynamic discovery of supported features and associated error handling.

The base functionality for the Gx reference point is the 3GPP Rel. 7 standard and a feature is an extension to that functionality. If the origin host does not support any features beyond the base functionality, the Supported-Features AVP may be absent from the Gx commands. As defined in 3GPP TS 29.229, when extending the application by adding new AVPs for a feature, the new AVPs will have the M bit cleared and the AVP will not be defined mandatory in the command ABNF.

The Supported-Features AVP is of type grouped and contains the Vendor-Id, Feature-List-ID and Feature-List AVPs. On the Gx reference point, the Supported-Features AVP is used to identify features that have been defined by 3GPP and hence, the Vendor-Id AVP will contain the vendor ID of 3GPP (10415). If there are multiple feature lists defined for the Gx reference point, the Feature-List-ID AVP will differentiate those lists from one another.

Feature bit	Feature	M/O	Description
0	Rel8	M	This feature indicates the support of base 3GPP Rel-8 Gx functionality, including the AVPs and corresponding procedures supported by the base 3GPP Rel-7 Gx standard, but excluding those features represented by separate feature bits.
1	Rel9	M	This feature indicates the support of base 3GPP Rel-9 Gx functionality, including the AVPs and corresponding procedures supported by the Rel8 feature bit, but excluding those features represented by separate feature bits.
3	Rel10	M	This feature indicates the support of base 3GPP Rel-10 Gx functionality, including the AVPs and corresponding procedures supported by the Rel8 and Rel9 feature bit, but excluding those features represented by separate feature bits.
4	SponsoredConnectivity	O	This feature indicates support for sponsored data connectivity feature. If the PCEF supports this feature, the PCRF may authorize sponsored data connectivity to the subscriber.

If PCEF configures Diameter dictionary as release 8, 9 or 10, then PCRF sends Supported-Features AVP so that PCEF will know what feature PCRF supports. If PCEF receives supported features lesser than or greater than requested features then supported feature will be mapped to the lower one.

Whenever the custom dictionary "dpca-custom24" is configured, the Supported-Features AVP including Vendor-Id AVP will be sent in all CCR messages.

Rule-Failure-Code AVP

The Rule-Failure-Code AVP indicates the reason that the QoS/PCC rules cannot be successfully installed/activated or enforced. The Rule-Failure-Code AVP is of type Enumerated. It is sent by the PCEF to the PCRF within a Charging-Rule-Report AVP to identify the reason a PCC Rule is being reported.

There are two new rule failure codes INCORRECT_FLOW_INFORMATION (12) and NO_BEARER_BOUND (15) are added. The name of the existing rule failure code 9 is changed to MISSING_FLOW_INFORMATION. For 3GPP Rel. 10, rule failure code 9 maps to GW/PCEF_MALFUNCTION.

Sponsored Data Connectivity

With Sponsored Data Connectivity, the sponsor has a business relationship with the operator and the sponsor reimburses the operator for the user's data connectivity in order to allow the user access to an associated Application Service Provider's (ASP) services. Alternatively, the user pays for the connectivity with a transaction which is separate from the subscriber's charging. It is assumed the user already has a subscription with the operator.

Sponsored Data Connectivity feature is introduced in Rel. 10 of 3GPP TS 29.212 specification. If Sponsored Data Connectivity is supported, the sponsor identity for a PCC rule identifies the 3rd party organization (the sponsor) who is willing to pay for the operator's charge for connectivity required to deliver a service to the end user.

The purpose of this feature is to identify the data consumption for a certain set of flows differently and charge it to sponsor. To support this, a new reporting level "SPONSORED_CONNECTIVITY_LEVEL" is added for reporting at Sponsor Connection level and two new AVPs "Sponsor-Identity" and "Application-Service-Provider-Identity" have been introduced at the rule level.

Sponsored Data Connectivity will be performed for service data flows associated with one or more PCC rules if the information about the sponsor, the application service provider and optionally the threshold values are provided by the Application Function (AF).

The provisioning of sponsored data connectivity per PCC rule will be performed using the PCC rule provisioning procedure. The sponsor identity will be set using the Sponsor-Identity AVP within the Charging-Rule-Definition AVP of the PCC rule. The application service provider identity will be set using the Application-Service-Provider-Identity AVP within the Charging-Rule-Definition AVP of the PCC rule. Sponsor-Identity AVP and Application-Service-Provider-Identity AVP will be included if the Reporting-Level AVP is set to the value SPONSORED_CONNECTIVITY_LEVEL.

When receiving the flow based usage thresholds from the AF, the PCRF will use the sponsor identity to generate a monitoring key. The PCRF may also request usage monitoring control, in this case, only the flow based usage is applied for the sponsored data connectivity. If requested, the PCEF may also report the usage to the PCRF.

A new CLI command "**diameter encode-supported-features**" has been added in Policy Control Configuration mode to send supported features with Sponsor Identity. For more information on the command, see the *Command Line Interface Reference*.

Sponsored connectivity feature will be supported only when both P-GW and PCRF support 3GPP Rel. 10. P-GW advertises release as a part of supported features in CCR-I to PCRF. If P-GW supports Release 10 and

also sponsored connectivity but PCRF does not support it (as a part of supported features in CCA-I), this feature will be turned off.

Sponsored connectivity is supported with "dpca-custom8" Gx dictionary. When a session is enabled for sponsored connectivity from PCRF and offline charging is enabled using aaa-custom4 dictionary, sponsored connectivity AVPs are reported in ACR interim and ACR Stop packets to the CDF server. The AVPs Sponsor-Identity and Application-Service-Provider-Identity are sent under grouped AVP Service-Data-Container in ACR packets.

This feature supports dynamic rules and Gx dictionary—dpca-custom 15 and dpca-custom8.

Volume Reporting

For Volume Reporting over Gx, PCRF generates a unique monitoring key based on sponsor identity. Since flows with different monitoring keys are treated differently, flows with sponsor ID are charged differently.

Supported Gx Features

Assume Positive for Gx

In a scenario where both the primary and secondary PCRF servers are overloaded, the PCRF returns an error to P-GW and HSGW. Current behavior for the P-GW and HSGW is to terminate the session if both primary and secondary return a failure or timeout.

This feature is developed to enhance this behavior by applying local policy on the GW to ensure that the subscriber session continues. P-GW / HSGW should implement Assume Positive feature to handle errors and based on the event type implement specific rules.



Important Use of Gx Assume Positive requires that a valid license key be installed. Contact your Cisco account representative for information on how to obtain a license.

The failure handling behavior is enhanced to ensure that the subscriber service is maintained in case of PCRF unavailability. It is also required that the GW reduces the traffic towards the PCRF when receiving a Diameter Too Busy (3004) by stopping the transmission and reception of Diameter messages (CCRs and RARs) to and from the PCRF for a configurable amount of time.

In case of any of the following failures with PCRF, the GW chooses to apply failure handling which results in subscriber termination or to allow browsing without any more policy enforcement.

- TCP link failure
- Application Timer (Tx) expiry
- Result code based failures

The PCRF is allowed to fall back to Local Policy for all connection level failures, result code/experimental result code failures. Local Policy may choose to allow the subscriber for a configured amount of time. During this time any subscriber/internal event on the call would be handled from Local Policy. After the expiry of the timer, the subscriber session can be either terminated or else PCRF can be retried. Note that the retry attempt to PCRF happens only when the **timer-expiry event** is configured as **reconnect-to-server**.

The fallback support is added to the failure handling template and the local policy service needs to be associated to IMS Authorization service.

Once the local policy is applied, all PCRF enabled event triggers will be disabled. When the subscriber session is with the local-policy, the GW skips sending of CCR-T and cleans up the session locally.

For a session that was created with active Gx session, the GW sends the CCR-T to primary and on failure sends the CCR-T to the secondary PCRF. If the CCR-T returns a failure from both primary and secondary or times out, the GW cleans up the session locally.

Fallback to Local Policy is done in the following scenarios:

- Tx timer expiry
- Database Error
- Result Code Error (Permanent/Transient)
- Experimental Result Code
- Response Timeout

The following points are applicable only in the scenario where reconnect to PCRF is attempted.

- If the subscriber falls back to local-policy because of CCR-I failure, CCR-I will be sent to the PCRF after the timer expiry. On successful CCA-I call will be continued with PCRF or else the call will be continued with local-policy and retry-count will be incremented.
- If the subscriber falls back to local-policy because of the CCR-U failure, IMS Authorization application waits for some event change to happen or to receive an RAR from PCRF.
- In case of event change after the timer expiry, CCR-U will be sent to PCRF. On successful CCA-U message, call will be continued with PCRF or else call will be with local-policy and retry-count will be incremented.
- If RAR is received after the timer-expiry the call will be continued with the PCRF. On expiry of maximum of retries to connect to PCRF, call will be disconnected.

Default Policy on CCR-I Failure

The following parameters are supported for local configuration on P-GW. The configuration parameters are configurable per APN and per RAT Type.

The following fields for a Default Bearer Charging Rule are configurable per APN and per RAT Type:

- Rule Name
- Rating Group
- Service ID
- Online Charging
- Offline Charging
- QCI
- ARP
 - Priority Level
 - QCI
 - QVI
- Max-Requested-Bandwidth
 - UL
 - DL

Flow Description and Flow Status are not configurable but the default value will be set to Any to Any and Flow Status will be set to Enabled.

The following command level fields are configurable per APN and per RAT Type:

- AMBR
 - UL
 - DL
- QCI
- ARP
 - Priority Level
 - QCI
 - QVI

Gx Back off Functionality

This scenario is applicable when Primary PCRF cluster is unavailable but the secondary PCRF is available to handle new CCR-I messages.

When the chassis receives 3004 result-code then back-off timer will be started for the peer and when the timer is running no messages will be sent to that peer.

The timer will be started only when the value is being configured under endpoint configuration.

P-GW/GGSN provides a fair chance for the subscriber to reconnect with PCRF in the event of CCR failure. To support this feature, configurable validity and peer backoff timers are introduced in the Local Policy Service and Diameter endpoint configuration commands. Also, the RAR received when the local-policy timer is running will be rejected with the cause "DIAMETER_UNABLE_TO_DELIVER".

The rule report will be sent to the PCRF during reconnect when the CLI command **diameter encodeevent-avps local-fallback** is configured under Policy Control Configuration mode.

Support for Volume Reporting in Local Policy

This feature provides support for time based reconnect to PCRF instead of the event based for CCR-U failure scenarios.

The following behaviors was observed with respect to the Volume Reporting for Local Policy:

- In the event of CCR-U failure, CCR-U was triggered to PCRF only on receiving subscriber event.
- When a CCR-U failure happened and a call continued without Gx, unreported volume is lost as the threshold is set to infinity. In next CCR-U triggered to PCRF, the cumulative volume was sent to PCRF.
- RAR was rejected with result-code diameter_unable_to_comply (3002) when the validity timer is running.

After the timer-based implementation, this feature introduces the following changes to the existing behavior:

- When send-usage-report is configured, the CCR-U with usage report will be sent immediately after the local-policy timer-expiry.
- The unreported usage will not be returned to ECS. Thus, usage since last tried CCR-U will be sent to PCRF.
- RAR will be accepted and the rules received on RAR will be installed even when the timer is running.

Session can be connected to PCRF immediately instead of waiting for subscriber event, and the updated usage report can be sent.

Support for Session Recovery and Session Synchronization

Currently PCRF and ASR 5500 gateway node are in sync during normal scenarios and when Gx assume positive is not applied. However, there are potential scenarios where the PCRF might have been locally deleted or lost the Gx session information and it is also possible that due to the loss of message, gateway node and PCRF can be out of sync on the session state.

While these are rare conditions in the network, the desired behavior is to have PCRF recover the Gx session when it is lost and also to have PCRF and gateway sync the rule and session information. This feature provides functionality to ensure PCRF and gateway can sync on session information and recover any lost Gx sessions. Configuration support has been provided to enable session recovery and session sync features.

The gateway (GW) node and PCRF supports the ability to exchange session information and the GW provides the complete subscriber session information to enable PCRF to build the session state. This will prevent the occurrence of the above mentioned scenarios and ensure that GW and PCRF are always in sync. The keywords **session-recovery** and **session-sync** are used with the **diameter encode-supported-features** CLI command in Policy Control Configuration mode to support Gx Synchronization.

Configuring Gx Assume Positive Feature

To configure Gx Assume Positive functionality:

-
- Step 1** At the global configuration level, configure Local Policy service for subscribers as described in the [Configuring Local Policy Service at Global Configuration Level, on page 563](#).
 - Step 2** At the global configuration level, configure the failure handling template to use the Local Policy service as described in the [Configuring Failure Handling Template at Global Configuration Level, on page 564](#).
 - Step 3** Within the IMS Authorization service, associate local policy service and failure handling template as described in the [Associating Local Policy Service and Failure Handling Template, on page 564](#).
 - Step 4** Verify your configuration as described in the [Verifying Local Policy Service Configuration, on page 565](#).
 - Step 5** Save your configuration to flash memory, an external memory device, and/or a network location using the Exec mode command **save configuration**. For additional information on how to verify and save configuration files, refer to the *System Administration Guide* and the *Command Line Interface Reference*.

Important Commands used in the configuration examples in this section provide base functionality to the extent that the most common or likely commands and/or keyword options are presented. In many cases, other optional commands and/or keyword options are available. Refer to the *Command Line Interface Reference* for complete information regarding all commands.

Configuring Local Policy Service at Global Configuration Level

Use the following example to configure Local Policy Service at global configuration level for subscribers:

```

configure
  local-policy-service LOCAL_PCC
    ruledef 2G_RULE
      condition priority 1 apn match .*
    exit
    ruledef all-plmn
      condition priority 1 serving-plmn match .*
    exit

```

```

    actiondef 2G_UPDATE
        action priority 1 activate-ambr uplink 18000 downlink 18000
        action priority 2 reject-requested-qos
        exit
    actiondef action1
        action priority 2 allow-requested-qos
        exit
    actiondef allow
        action priority 1 allow-session
        exit
    actiondef delete
        action priority 1 terminate-session
        exit
    actiondef lp_fall
        action priority 1 reconnect-to-server
        exit
    actiondef time
        action priority 1 start-timer timer duration 10
    exit
    eventbase default
        rule priority 1 event fallback ruledef 2G_RULE actiondef time
continue
        rule priority 2 event new-call ruledef 2G_RULE actiondef action1
        rule priority 3 event location-change ruledef 2G_RULE actiondef
action1
        rule priority 5 event timer-expiry ruledef 2G_RULE actiondef
lp_fall
        rule priority 6 event request-qos default-qos-change ruledef
2G_RULE actiondef allow
    end

```

Notes:

- On occurrence of some event, event will be first matched based on the priority under the eventbase default. For the matched rule and if the corresponding ruledef satisfies, then specific action will be taken.

Configuring Failure Handling Template at Global Configuration Level

Use the following example to configure failure handling template at global configuration level:

```

configure
    failure-handling-template <template_name>
        msg-type any failure-type any action continue local-fallback
    end

```

Notes:

- When the TCP link failure, Application Timer (Tx) expiry, or Result code based failure happens, the associated failure-handling will be considered and if the failure-handling action is configured as local-fallback, then call will fall back to local-fallback mode.

Associating Local Policy Service and Failure Handling Template

Use the following example to associate local policy service and failure handling template:

```

configure
  context <context_name>
    ims-auth-service <service_name>
      associate local-policy-service <lp_service_name>
      associate failure-handling <failure-handling-template-name>
    end
  end

```

Verifying Local Policy Service Configuration

To verify the local policy service configuration, use this command:

```
show local-policy statistics service service_name
```

Time Reporting Over Gx

This section describes the Time Reporting over Gx feature supported for GGSN in this release.

License Requirements

No separate license is required for Time Reporting over Gx feature. This feature can be enabled as part of "Policy Interface" license.

Contact your Cisco account representative for detailed information on specific licensing requirements. For information on installing and verifying licenses, refer to the *Managing License Keys* section of the *Software Management Operations* chapter in the *System Administration Guide*.

Feature Overview

This non-standard Time Usage Reporting over Gx feature is similar to Volume Usage Reporting over Gx. PCRF provides the time usage threshold for entire session or particular monitoring key in CCA or RAR. When the given threshold breached usage report will be sent to PCRF in CCR. This time threshold is independent of data traffic. Apart from the usage threshold breach there are other scenarios where usage report will be sent to PCRF.



Important

Time reporting over Gx is applicable only for time quota.

The PCEF only reports the accumulated time usage since the last report for time monitoring and not from the beginning.

If the time usage threshold is set to zero (infinite threshold), no further threshold events will be generated by PCEF, but monitoring of usage will continue and be reported at the end of the session.

Time usage reporting on bearer termination is supported. When a bearer is deleted due to some reason, the rules associated with the bearer will also be removed. So, the usage will be reported on the monitoring key(s) whose associated rule is the last one that is removed because of bearer termination.

The following steps explain how Time Reporting over Gx works:

1. PCEF after receiving the message from PCRF parses the time monitoring related AVPs, and sends the information to IMSA.
2. IMSA updates the information to ECS.

3. Once the ECS is updated with the time monitoring information from PCRF, the PCEF (ECS) starts tracking the time usage.
4. For session-level monitoring, the ECS maintains the amount of time usage.
5. For PCC rule monitoring, usage is monitored with the monitoring key as the unique identifier. Each node maintains the time usage information per monitoring key.
6. The PCEF continues to track time usage after the threshold is reached and before a new threshold is provided by the PCRF. If a new usage threshold is not provided by the PCRF in the acknowledgement of an IP-CAN Session modification where its usage was reported, then time monitoring does not continue in the PCEF for that IP CAN session.

Limitations

This section lists the limitations for Time Reporting over Gx in this release.

- Only integer monitoring key will be supported like Volume Reporting over Gx
- If the same monitoring key is used for both time and data volume monitoring then disabling monitoring key will disable both time and data usage monitoring.
- If the same monitoring key is used for both time and data usage monitoring and if an immediate report request is received, then both time and volume report of that monitoring key will be sent.

Usage Monitoring

Two levels of time usage reporting are supported:

- Usage Monitoring at Session Level
- Usage Monitoring at Flow Level

Usage Monitoring at Session Level

PCRF subscribes to the session level time reporting over Gx by sending the Usage-Monitoring-Information AVP with the usage threshold level set in Granted-Service-Unit AVP and Usage-Monitoring-Level AVP set to SESSION_LEVEL (0).

Usage Monitoring at Flow Level

PCRF subscribes to the flow level time reporting over Gx by sending the Usage-Monitoring-Information AVP with the usage threshold level set in Granted-Service-Unit AVP and Usage-Monitoring-Level AVP set to PCC_RULE_LEVEL(1). Monitoring Key is mandatory in case of a flow level monitoring since the rules are associated with the monitoring key and enabling or disabling of usage monitoring at flow level can be controlled by PCRF using it. Usage monitoring is supported for both predefined rules and dynamic rule definition.

Usage Monitoring for Predefined and Static Rules

If the usage monitoring needs to be enabled for the predefined rules, PCRF sends the rule and the usage monitoring information containing the monitoring key and the usage threshold. The monitoring key should be same as the one pre-configured in PCEF for that predefined rule. There can be multiple rules associated with the same monitoring key. Hence enabling a particular monitoring key would result in the time being tracked for multiple rules having the same monitoring key. Similarly, usage monitoring information is sent from PCRF for the static rules also.

Usage Monitoring for Dynamic Ruledefs

If the usage monitoring needs to be enabled for dynamic ruledefs, PCRF provides the monitoring key along with a charging rule definition and the usage monitoring information containing the monitoring key and the usage threshold. This results in the usage monitoring being done for all the rules associated with that monitoring key.

Usage Reporting

Time usage at subscriber/flow level is reported to PCRF under the following conditions:

- **Usage Threshold Reached:** PCEF records the subscriber usage and checks if the usage threshold provided by PCRF is reached. Once the condition is met, it reports the usage information to IMSA and continues monitoring. IMSA then triggers the CCR-U if "USAGE_REPORT" trigger is enabled by PCRF. The Usage-Monitoring-Information AVP is sent in this CCR with the "CC-Time" in "Used-Service-Unit" set to track the time usage of the subscriber.
- **Usage Monitoring Disabled:** If PCRF explicitly disables the usage monitoring with Usage-Monitoring-Support AVP set to USAGE_MONITORING_DISABLED, PCEF stops monitoring and reports the usage information (when the monitoring was enabled) to PCRF if the usage monitoring is disabled by PCRF as a result of CCR from PCEF which is not related to reporting usage, other external triggers, or a PCRF internal trigger.
- **IP CAN Session Termination:** When the IP CAN session is terminated, the accumulated subscriber usage information is reported to PCRF in the CCR-T from PCEF.

PCRF uses RAR message and includes Session-Release-Cause AVP in it to initiate IP CAN Session Termination. However, there are some scenarios where PCRF may want to terminate the IP CAN Session in CCA messages. In order to avoid an unnecessary additional message, PCRF can inform P-GW to terminate the subscriber in CCA-U message itself. Hence, the Session Release Cause has been added in CCA messages for all Gx dictionaries.

- **PCC Rule Removal:** When the PCRF deactivates the last PCC rule associated with a usage monitoring key, PCEF sends a CCR with the usage time for that monitoring key. If the PCEF reports the last PCC rule associated with a usage monitoring key is inactive, the PCEF reports the accumulated usage for that monitoring key within the same CCR command if the Charging-Rule-Report AVP was included in a CCR command; otherwise, if the Charging-Rule-Report AVP was included in an RAA command, the PCEF sends a new CCR command to report accumulated usage for the usage monitoring key.
- **PCRF Requested Usage Report:** When PCRF provides the Usage-Monitoring-Information with the Usage-Monitoring-Report set to USAGE_MONITORING_REPORT_REQUIRED, PCEF sends the time usage information. If the monitoring key is provided by PCRF, time usage for that monitoring key is notified to PCRF regardless of usage threshold. If the monitoring key is not provided by PCRF, time usage for all enabled monitoring keys is notified to PCRF.
- **Event Based Reporting:** The event based reporting can be enabled through the CLI command **event-update send-usage-report events**. When an event like sgsn change, qos change or revalidation-timeout is configured under this CLI, time usage report is generated whenever that event happens.

Once the usage is reported, the usage counter is reset to zero. The PCEF continues to track time usage from the zero value after the threshold is reached and before a new threshold is provided by the PCRF. If a new usage threshold is not provided by the PCRF in the acknowledgement of an IP-CAN Session modification where its usage was reported, then time usage monitoring does not continue in the PCEF for that IP CAN session.

For information on how to configure the Time Reporting over Gx feature, see the [Configuring Time Reporting over Gx, on page 568](#).

Configuring Time Reporting over Gx

This section describes the configuration required to enable Time Reporting over Gx.

To enable Time Reporting over Gx, use the following configuration:

```
configure
  active-charging service <ecs_service_name>
    rulebase <rulebase_name>
      action priority <priority> dynamic-only ruledef <ruledef_name>
    charging-action <charging_action_name> monitoring-key <monitoring_key>
    exit
  exit
  context <context_name>
    ims-auth-service <imsa_service_name>
      policy-control
        event-update send-usage-report [ reset-usage ]
      end
    end
```

Notes:

- The configuration for enabling Time Reporting over Gx is same as the Volume Reporting over Gx configuration. If a time threshold is received from PCRF then Time monitoring is done, and if a volume threshold is received then Volume monitoring will be done.
- The maximum accepted monitoring key value by the PCEF is 4294967295. If the PCEF sends a greater value, the value is converted to an Unsigned Integer value.
- The **event-update** CLI enables time usage report to be sent in event updates. The optional keyword **reset-usage** enables to support delta reporting wherein the usage is reported and reset at PCEF. If this option is not configured, the behavior is to send the time usage information as part of event update but not reset at PCEF.

Support for Multiple Active and Standby Gx Interfaces to PCRF

In the earlier Gx implementation, Diameter Policy Control Application has the limitation to mandatorily configure hosts as part of IMS Authorization service or associate a host template and select the hosts to be communicated for each subscriber session. Since the peer selection can happen at diabase and application need not select any hosts, this feature is developed to remove the restrictions imposed in the application and allow diabase to pick the peers in a round robin fashion. In addition, this feature will take care of peer selection at diabase even when the hosts picked by application are not active. This change in behavior is controlled through the CLI command "**endpoint-peer-select**" as the default behavior is to drop the call if the server discovery fails at application.

When the call is established, IMSA module checks the host selection table/prefix table/host template associated in IMSA service to pick the primary and secondary peers to be contacted. If no host table/prefix table/host template is configured or none of the rows in prefix table are matching or the hosts selected by IMSA are inactive, then based on the CLI configuration the control is given to diabase module which will select the peers in a round robin fashion or terminate the call based on the CLI configuration.

When the CCR message results in a diabase error/Tx expiry/response timeout, then IMSA will let diabase select an alternate route by excluding the peer which resulted in the failure and switch to the peer if the lookup is successful.

When CCR/CCA message is exchanged with the directly connected host selected by diabase and RAR message is received from new host, then IMSA will skip host configuration check and let further communication to happen with the new host. If the directly connected host is selected by application during call establishment, then IMSA will check if the new host is the secondary server per application. When the CCR/CCA message is exchanged with indirectly connected host through DRA which is picked by diabase and RAR message is received from same host through another DRA, then IMSA will skip host configuration check and let further communication to happen with the same host through the new DRA. If the DRA is selected by application during call establishment, then IMSA will check if the new DRA is the secondary server per application. Even if RAR message is received from different host though another DRA, IMSA will skip host configuration check and let further communication to happen with the new host through the new DRA.

Configuring Diameter Peer Selection at Diabase in Failure Scenarios

The following configuration enables diabase to select the Diameter peers when IMSA fails.

```

configure
  context context_name
    ims-auth-service service_name
      policy-control
        endpoint-peer-select [ on-host-select-failure |
on-inactive-host ]
        { default | no } endpoint-peer-select
      end

```

Notes:

- This command is used to perform server selection at diabase when the hosts could not be selected by IMS Authorization application or when the hosts selected by the IMS Authorization application is inactive. For example, host table is not configured in IMSA service, host table is configured but not activated, none of the rows in prefix table match the subscriber, host template is not associated with IMSA service, host template could not select the hosts.
- **on-host-select-failure**: Specifies to perform server selection at Diabase when the hosts could not be selected by IMS Authorization application.
- **on-inactive-host**: Specifies to perform server selection at diabase when the hosts selected by application are inactive.
- This CLI command is added in policy control configuration mode to maintain backward compatibility with the old behavior of terminating the call when server selection fails at IMS Authorization application.

Support for Multiple CCR-U's over Gx Interface

ASR 5500 supports multiple CCR-U messages at a time per session through the use of a configurable CLI command "**max-outstanding-ccr-u**" under IMS Authorization Service configuration mode. That is, this CLI will allow the user to configure a value of up to 12 as the maximum number of CCR-U messages per session.

The CLI-based implementation allows sending request messages as and when they are triggered and processing the response when they are received. The gateway does re-ordering if the response messages are received out of sequence.

To support multiple outstanding messages towards PCRF, the following items should be supported:

- Allowing IMSA to send multiple CCR-U messages – This can be achieved through the use of **max-outstanding-ccr-u** command in the IMS Authorization Service configuration mode.
- Queuing of response message for ordering – DPCA should parse the received message irrespective of order in which they are received. IMSA will check whether to forward the response to session manager or queue it locally.
- Peer switch – When multiple CCR-Us are triggered, IMSA will start Tx timer for each request sent out. On first Tx expiry, IMSA/DPCA will do peer switch. That is, IMSA will stop all other requests' Tx timers and switch to secondary peer (if available) or take appropriate failure handling action.
- Failure handling – On peer switch failure due to Tx expiry, DPCA will take failure handling action based on the configuration present under `ims-auth-service`.
- Handling back pressure – In case of multiple CCR-Us triggered to Primary PCRF and due to Tx timeout all the messages are switched to Secondary PCRF. If Secondary server is already in backpressure state, then IMSA will put first message in the backpressure queue and once after message is processed next pending request will be put into BP queue.
- Volume reporting – In case of multiple CCR-Us for usage report is triggered (for different monitoring keys) and failure handling is configured as "**continue send-ccrt-on-call-termination**", on first Tx timeout or response timeout, usage report present in all the CCR-Us will be sent to ECS. All the unreported usage will be sent in CCR-T message when the subscriber goes down. If "**event-update send-usage-report**" CLI is present, then there are chances of reporting usage for same monitoring key in multiple CCR-Us.

Though the **max-outstanding-ccr-u** CLI command supports configuring more than one CCR-U, only one outstanding CCR-U for access side update is sent out at a time and multiple CCR-Us for internal updates are sent.

These are the access side updates for which CCR-U might be triggered:

- Bearer Resource Command
- Modify Bearer Request (S-GW change, RAT change, ULI change)
- Modify Bearer Command

These are the following internal updates for which CCR-U is triggered:

- S-GW restoration
- Bearer going down (GGSN, BCM UE_Only)
- ULI/Timezone notification
- Default EPS bearer QoS failure
- APN AMBR failure
- Charging-Rule-Report
- Out of credit / reallocation of credit
- Usage reporting
- Tethering flow detection
- Access network charging identifier

Configuring Gateway Node to Support Back-to-Back CCR-Us

The following configuration enables or disables the gateway to send multiple back-to-back CCR-Us to PCRF.

```

configure
  context context_name
    ims-auth-service service_name
    policy-control

```

```
[ default ] max-outstanding-ccr-u value
end
```

Notes:

- *value* must be an integer value from 1 through 12. The default value is 1.

Support for RAN/NAS Cause IE on Gx Interface

New supported feature "Netloc-RAN-NAS-Cause" has been introduced to be in compliance with the Release 12 specification of 3GPP TS 29.212. This feature is used to send detailed RAN and/or NAS release cause code information from the access network to PCRF. It requires that the NetLoc feature is also supported.



Important This feature can be enabled only when the NetLoc feature license is installed.

A new Diameter AVP "RAN-NAS-Release-Cause" will be included in the Charging-Rule-Report AVP and in CCR-T for bearer and session deletion events respectively, when the NetLoc-RAN-NAS-Cause supported feature is enabled. This AVP will indicate the cause code for the subscriber/bearer termination.

Configuring Supported Feature Netloc-RAN-NAS-Cause

The following configuration enables the supported feature "Netloc-RAN-NAS-Cause".

```
configure
  context context_name
    ims-auth-service service_name
      policy-control
        diameter encode-supported-features netloc-ran-nas-cause
      end
    end
```

Notes:

- **netloc-ran-nas-cause**: Enables the Netloc-RAN-NAS-Cause feature. By default, this supported feature will be disabled.
- If the supported features "netloc-ran-nas-code" and "netloc" are enabled, then netloc-ran-nas-cause code will be sent to PCRF.

To disable this supported feature, use the following command:

```
[ default | no ] diameter encode-supported-features
```

Support ADC Rules over Gx Interface

In this release, P-GW will use Application Detection and Control (ADC) functionality over Gx as defined in the Release 11 specification of 3GPP standard.

ADC extension over Gx provides the functionality to notify PCRF about the start and stop of a specific protocol or a group of protocols, and provide the possibility to PCRF that with the knowledge of this information, change the QoS of the user when the usage of application is started and until it is finished.

The provision of ADC information is done through the ADC rule, the action initiated by PCRF is done through the PCC rule.

ADC rules are certain extensions to dynamic and predefined PCC rules in order to support specification, detection and reporting of an application flow. These rules are installed (modified/removed) by PCRF via CCA-I/CCA-U/RAR events. ADC rules can be either dynamic PCC or predefined PCC rules, and the existing attributes of dynamic and predefined rules will be applicable.

Dynamic PCC rule contains either traffic flow filters or Application ID. When Application ID is present, the rule is treated as ADC rule. Application ID is the name of the ruledef which is pre-defined in the boxer configuration. This ruledef contains application filters that define the application supported by P2P protocols.

PCEF will process and install ADC rules that are received from PCRF interface, and will detect the specified applications and report detection of application traffic to the PCRF. PCRF in turn controls the reporting of application traffic.

PCEF monitors the specified applications that are enabled by PCRF and generates Start/Stop events along with the Application ID. Such application detection is performed independent of the bearer on which the ADC PCC rule is bound to. For instance, if ADC rule is installed on a dedicated bearer whereas the ADC traffic is received on default bearer, application detection unit still reports the start event to PCRF.



Important ADC Rule support is a licensed-controlled feature. Contact your Cisco account representative for detailed information on specific licensing requirements.

In support of this feature, the following Diameter AVPs are newly added to the Charging-Rule-Definition AVP, which PCEF will receive from PCRF.

- TDF-Application-Identifier: It references the application detection filter which the PCC rule for application detection and control in the PCEF applies. The TDF-Application-Identifier AVP references also the application in the reporting to the PCRF.
- Redirect-Information: This indicates whether the detected application traffic should be redirected to another controlled address.
- Mute-Notification: This AVP is used to mute the notification to the PCRF of the detected application's start/stop for the specific ADC/PCC rule from the PCEF.
- Application Detection Information: If Mute-Notification AVP is not enclosed with charging rule report and APPLICATION_START/APPLICATION_STOP event trigger is enabled then PCEF will send Application-Detection-Information to PCRF corresponding TDF-Application-Identifier.

In addition, these two new event triggers "APPLICATION_START" and "APPLICATION_STOP" are generated for reporting purpose.

Limitations

The limitations for the ADC over Gx feature are:

- ADC does not support group of ruledefs.
- Registration of the duplicate application IDs are not supported.
- Readdress/Redirection for P2P flows will not be supported.
- Redirection happens only on transactions of GET/Response.
- Port based, IP Protocol based, and URL based applications are not supported.
- Pre-configured options (precedence, redirect-server-ip) for dynamic ADC rules are not supported.
- Simultaneous instances of an application for the same subscriber are not distinguished.
- Flow recovery is not supported for application flows.

Configuring ADC Rules over Gx

The following configuration enables ADC rules over Gx interface.

```
configure
  context context_name
    ims-auth-service service_name
      policy-control
        diameter encode-supported-features adc-rules
      end
    end
```

Notes:

- The keyword "**adc-rules**" will be available only when the feature-specific license is configured.
- For ADC 6th bit of supported feature will be set.

To disable the support for ADC Rules over Gx, use the following command:

```
[ default | no ] diameter encode-supported-features
```

GoR Name Support in TDF-Application-Identifier

ASR 5500 supports dynamic rules to be installed with GoR name as TDF-Application-Identifier. When ADC rule is installed as a dynamic rule from PCRF, the TDF-Application-Identifier can include the GoR name pre-configured in the P-GW.

If the ADC feature is enabled, PCRF can send TDF-Application-Identifier as the name of GoR predefined in the P-GW configuration.

- When dynamic charging-rules with the Charging-Rule-Definition AVP are activated from PCRF, the PCRF can specify the GoR name configured in ECS as TDF-Application-Identifier.
- When dynamic charging-rules with the Charging-Rule-Definition AVP are activated, the PCRF can remove or modify the rule through the Charging-Rule-Definition using RAR. During rule activation or modification, the PCRF can add, modify or remove the charging-rule attributes of the rule.

The configuration changes for TDF-Application-Identifier from PCRF are listed below:

- A non-ADC dynamic rule can be changed to ADC dynamic rule by sending TDF-Application-Identifier AVP with relevant ruledef or GoR name.

ADC dynamic rule cannot be changed to non-ADC dynamic rule.

- The following AVPs will be modified and applied when received from PCRF:
 - Precedence
 - Rating-Group/Service-Identifier/Sponsor-Identity (mandatory depending on the Reporting-Level)
 - Metering-Method
 - Online/Offline
 - QoS-Information
 - Monitoring-Key
 - Redirect-Information

- Dynamic route will be updated for all protocols of rules that are part of TDF-Application-Identifier GoR.
- Any change in dynamic rule priority or TDF-Application-Identifier value will lead to sending of APP-START and APP-STOP event notifications as new rule match. If an APP-START notification was sent already before rule modification, the corresponding APP-STOP notification will not be sent.
- Runtime deletion of associated GoR will take immediate effect and APP-STOP notification will not be sent if an APP-START was already sent. Addition of GoR at service level will need to have rules to be re-installed for the new addition to take effect for both dynamic and predefined ADC rules.

ADC Mute Customization

Earlier, 3GPP ADC over Gx did not support application MUTE status change. Once the application was muted, it was not possible to unmute it. From release 21.1, this feature introduces custom MUTE/UNMUTE functionality. ASR 5500 PCEF now supports customization to control reporting of the Application Detection Information CCRUs. For this, an AVP has been introduced with two possible values - custom MUTE and custom UNMUTE.

- A Gx message might contain both Standards based MUTE and the custom MUTE.
- Standards based MUTE is given preference over the custom MUTE/UNMUTE.
- A dynamic ADC rule can be installed and modified with a custom MUTE.
- Custom-Mute-Notification AVP can be sent by the PCRF in CCA-I and RAR.
- A dynamic ADC rule can be modified with a custom UNMUTE.
- On a custom MUTE for a given dynamic ADC rule, PCEF sends a single APPLICATION_START/ APPLICATION_STOP response for the entire application traffic rather the per flow APPLICATION_START /APPLICATION_STOP response.
- On a custom MUTE for a given dynamic ADC rule, if no APPLICATION_START has been sent prior to the custom MUTE then a single APPLICATION_START is sent on the next flow packet that hits the dynamic rule.
- On a custom MUTE for a given dynamic rule, the APPLICATION_START response is sent with the flow's 5-tuple information.
- On a custom MUTE for a given dynamic rule, the APPLICATION_START response is sent with TDF-Application-Instance-Identifier = 0.
- On a custom MUTE for a given dynamic rule, a single APPLICATION_STOP is sent when the last flow associated with the given dynamic rule is terminated. Such an APPLICATION_STOP will not contain 5-tuple information of the last flow and is sent with TDF-Application-Instance-Identifier = 0.
- On a custom UNMUTE for a given dynamic rule, APPLICATION STARTs response is matched with the given dynamic rule and then sent to all the forthcoming flows.
- There is no change in behavior for a custom UNMUTE, which has not been custom MUTED or standard MUTED before UNMUTING. APPLICATION_STARTs and APPLICATION_STOPs is continued to be sent per flow as before.
- On a custom UNMUTE, PCEF sends an APPLICATION_STOP each for all flows that terminate then onwards.
- A given dynamic rule is recovered in both SR and ICSR including the Custom MUTE/UNMUTE status. The APPLICATION_START status for a given dynamic rule is check-pointed and recovered. This ensures that an extra APPLICATION_START is not sent to the PCRF post recoveries.

Enhancement to the ADC Custom Mute/Unmute Functionality

Feature Information

Summary Data

Status	Modified Functionality
Introduced-In Release	21.1
Modified-In Release(s)	21.2
Applicable Product(s)	SAEGW
Applicable Platform(s)	ASR 5500
Default Setting	Disabled
Related CDETS ID(s)	CSCvd00699
Related Changes in This Release	Not Applicable
Related Documentation	Command Line Interface Reference SAEGW Administration Guide

Revision History



Important Revision history details are not provided for features introduced before release 21.2.

Revision Details	Release	Release Date
Modified in this release.	21.2	April 27, 2017

Feature Changes

The "ADC mute customization" feature introduced custom MUTE/UNMUTE functionality to control reporting of the Application Detection Information CCRUs. With the custom MUTE PCRF AVP, the PCRF informed P-GW when to disable/enable the ADC application notifications.

This feature enhances the "ADC mute customization" feature further and report the flow activities between custom mute and unmute events. P-GW learns the flow activities between custom mute events and then reports them to PCRF after the custom unmute event has occurred on the ADC rule. It minimizes the ADC application start and stop mechanism in standard ADC mute and unmute case.

A new CLI command has been implemented at the rulebase, which when configured, reports ADC application start and stop notifications only once per rule. This helps in reducing messaging flows towards the PCRF.

Limitations

Following are the limitations of this feature:

- P-GW stores maximum of 12 learned flows per ADC rule. Once the limit 12 has been reached, P-GW forgets the oldest flow and learns about the latest flow. Once P-GW receives the custom unmute event, it notifies the PCRF about the learned notifications. P-GW sends application stop notification, if the application start notification for the flow is sent.
- Flow information stored for sending the application start notifications to the PCRF after the event of the custom unmute is not recovered.
- On LTE to WiFi handover, the values received from the PCRF for custom mute or custom unmute per ADC dynamic rule gets applied in the new RAT. If there is no value received in the handover context, the previous values before the RAT change are retained for all the ADC dynamic rules which are present.
- If the CLI command **adc notify** is enabled, then the single ADC application start and stop notification is notified to the PCRF. If there are multiple flows which match the same ADC dynamic rule, only one application start and stop notification is sent to the PCRF.
- This feature is implemented only for the dynamic rules.

How it Works

Following is the sequence of events that occur when P-GW receives packet and ADC rule event occurs from PCRF:

1. Packet reaches the ECS rule matching engine.
2. The rule matching engine checks if the ADC dynamic rule is matched. It also checks if the custom mute is applied through the PCRF or rulebase level CLI. A single application start notification is sent, if not sent earlier.
3. For all the subsequent flows matching the same ADC rule, application start notification is stored. These notifications are sent in the CCRU after the custom unmute event is received.

Following are some important points:

- The values received from the PCRF has the highest priority. Hence, standard mute has the highest priority than custom-mute/custom-unmute. The CLI *adc notify once* has the least priority.
- If the CLI **adc notify once** is configured at the rulebase, the converse **no adc notify** does not have any impact. To converse the CLI impact, do either of the following tasks:
 - Switch the rulebase in which the CLI **adc notify once** is not configured.
 - Send the "custom unmute" for that particular dynamic rule.

Configuring the ADC Notifications

The new CLI command, **adc notify**, has been added to the active charging service mode.

When this CLI is configured, a single application start or application stop notification for the ADC flow matching per rule is sent to the PCRF. If this CLI is configured and the PCRF sends the custom mute notification, then the PCRF notification takes precedence over the standard behavior for reporting the notification.

The default value of this keyword is false. If this CLI is not configured, then no action is taken on sending the ADC notifications.

To enable or disable the feature, enter the following commands:

```

configure
  active-charging service <service_name>
    rulebase <rulebase_name>
      [no] adc notify [once]
    end
end

```

For configuring single notification use the following command:

```
adc notify once
```

Notes:

- **no:** Disables the ADC notifications and ADC notifications are sent as per default behavior.
- **adc:** Configures the ADC notifications.
- **notify:** Configures the application notification. If this keyword is not configured, ADC notifications are sent as per default behavior.
- **once:** Configures the application notification only once. PCRF takes the priority.

Support for TAI and ECGI Change Reporting

This section describes the overview and implementation of TAI and ECGI Change Reporting feature.

This section discusses the following topics for this feature:

- [Feature Description, on page 577](#)
- [How it Works, on page 578](#)
- [Monitoring and Troubleshooting the TAI and ECGI Change Reporting Feature, on page 579](#)

Feature Description

For activating User Location Reporting for a UE over Gx, PCRF sends RAR/CCA with the "USER_LOCATION_CHANGE (13)" event trigger. On receiving this event trigger, P-GW typically sends Change Reporting Action (CRA) Information Element (IE) with "Start Reporting" towards MME to enable the Location-Change reporting for the UE in MME.

In the current architecture, the "USER_LOCATION_CHANGE (13)" trigger is used to report the changes in User Location Information (ULI), Tracking Area Identity (TAI) and E-UTRAN Cell Global Identifier (ECGI). CLI changes are done to display the new event triggers in show configuration commands.



Important For TAI reporting to work, the **diameter map usage-report** CLI command must be configured in Policy Control configuration mode to use the value 33.

PCRF subscribes to the CRA event for reporting change of TAI and ECGI. P-GW sends event trigger in CCR-U only if it is subscribed by PCRF. When PCRF installs the event trigger for ECGI Change and/or TAI change, any change in ECGI and TAI (based on installed triggers) is reported.

The TAI and ECGI Change Reporting feature complies with 3GPP TS 29.212 v9.7.0. This feature is supported on Gx interface so that UE can be tracked on ECGI/TAI change and reported to PCRF. For more information

on the User Location Information Reporting feature, see the administration guide for the product that you are deploying.

The CRA value varies based on the event triggers received from PCRF.

Change Reporting Support Indication (CRSI) and ULI are also supported in Bearer Resource Command.

P-GW sends the ULI received in Delete Bearer Command from MME to PCRF when the corresponding Delete Bearer Response is received. When the ULI is included in both Delete Bearer Command and Delete Bearer Response, the ULI in Delete Bearer Response is sent to the PCRF. In the absence of ULI in Delete Bearer Response, then the ULI received in Delete Bearer Command is sent to PCRF.

Relationships to Other Features

This feature has a dependency on USAGE_REPORT value of Event-Trigger AVP. This feature works only when the value of USAGE_REPORT is set to 33. This can be achieved using the **diameter map usage-report** CLI command in Policy Control configuration mode.

How it Works

P-GW sends Event Trigger value based on the event trigger detected by P-GW in CCR-U. P-GW sends Event Trigger and ULI Type in CCR-U to PCRF as per the following table.

Event Trigger from PCRF	CRA Value	Event Detected at P-GW	What to Inform PCRF
ULI_CHANGE	6	TAI_CHANGE or ECGI_CHANGE	Event Trigger: ULI_CHANGE ULI Type: TAI + ECGI
TAI_CHANGE	3	TAI_CHANGE	Event Trigger: TAI_CHANGE ULI Type: TAI
ECGI_CHANGE	4	ECGI_CHANGE	Event Trigger: ECGI_CHANGE ULI Type: ECGI
ULI_CHANGE + TAI_CHANGE	6	TAI_CHANGE	Event Trigger: ULI_CHANGE+ TAI_CHANGE ULI Type: TAI+ECGI
ULI_CHANGE + ECGI_CHANGE	6	ECGI_CHANGE	Event Trigger: ULI_CHANGE + ECGI_CHANGE ULI Type: TAI+ECGI
ULI_CHANGE + TAI_CHANGE + ECGI_CHANGE	6	TAI/ECGI has changed	Event Trigger: ULI_CHANGE + TAI/ECGI CHANGE ULI_Type: TAI+ECGI

Event Trigger from PCRF	CRA Value	Event Detected at P-GW	What to Inform PCRF
TAI_CHANGE + ECGI_CHANGE	6	TAI/ECGI has changed	Event Trigger: TAI_CHANGE/ECGI_CHANGE ULI_Type: TAI+ECGI
For combinations not specifically mentioned above	6		Event Trigger: ULI_CHANGE ULI_Type: TAI+ECGI

Limitations

TAI and ECGI Change Reporting feature is supported only when *diameter map usage-report* CLI command is configured as 33.

Monitoring and Troubleshooting the TAI and ECGI Change Reporting Feature

This section provides information regarding show commands and/or their outputs in support of the TAI and ECGI Change Reporting feature.

show ims-authorization sessions full all

The following fields are added to the output of this show command in support of this feature:

- TAI-Change - Displays this event trigger when TAI has changed for a subscriber session.
- ECGI-Change - Displays this event trigger when ECGI has changed for a subscriber session.

show ims-authorization service statistics all

The following statistics are added to the output of this show command in support of this feature:

- TAI Change - Displays the total number of times P-GW has reported TAI_CHANGE (26) event trigger to PCRF.
- ECGI Change - Displays the total number of times P-GW has reported ECGI_CHANGE (27) event trigger to PCRF.

Location Based Local-Policy Rule Enforcement

This section describes the overview and implementation of Location-based Local-Policy (LP) Rule Enforcement feature.

This section discusses the following topics for this feature:

- [Feature Description, on page 580](#)
- [How it Works, on page 580](#)
- [Configuring Location Based Local Policy Rule Enforcement Feature, on page 582](#)
- [Monitoring and Troubleshooting the Location Based LP Rule Enforcement Feature, on page 584](#)

Feature Description

This feature is introduced to activate different predefined rules for different E-UTRAN Cell Global Identifiers (ECGIs) when the subscriber is connected to a corporate APN. The subscriber has to explicitly bring down the connection with the corporate APN and re-establish session with Internet APN when out of the company area. It is assumed that corporate APN does not use PCRF and use only Local-Policy. In this case, all calls matching the APN is directed to the Local-Policy.



Important For this feature to work, the license to activate Local-Policy must be configured. For more information on the licensing requirements, contact your local Cisco account representative.

To activate different predefined rules for ECGI, Local-Policy configurations are enhanced to support:

- Configuration and validation of a set of ECGIs
- Installation of ECGI_CHANGE event trigger through Change Reporting Action (CRA) event
- Detection of ECGI_CHANGE event

This feature supports the following actions to be applied based on the ECGI match with Local-Policy ruledef condition:

- Enable a redirect rule on ECGI_CHANGE event notification when the ECGI belongs to a certain group
- Enable a wild card rule for any other ECGIs

Relationships to Other Features

This feature has a dependency on TAI and ECGI Change Reporting feature, which provides a framework to report ECGI-Change from session manager module to IMSA/Local-Policy module.

How it Works

This section describes how the Local Policy Rule selection and enforcement happens based on ECGI-CHANGE event trigger.

Flows

The following figure describes how the ECGI-CHANGE event is being handled in Local-Policy, MME and P-GW.

Figure 101: ECGI-CHANGE Event Handling

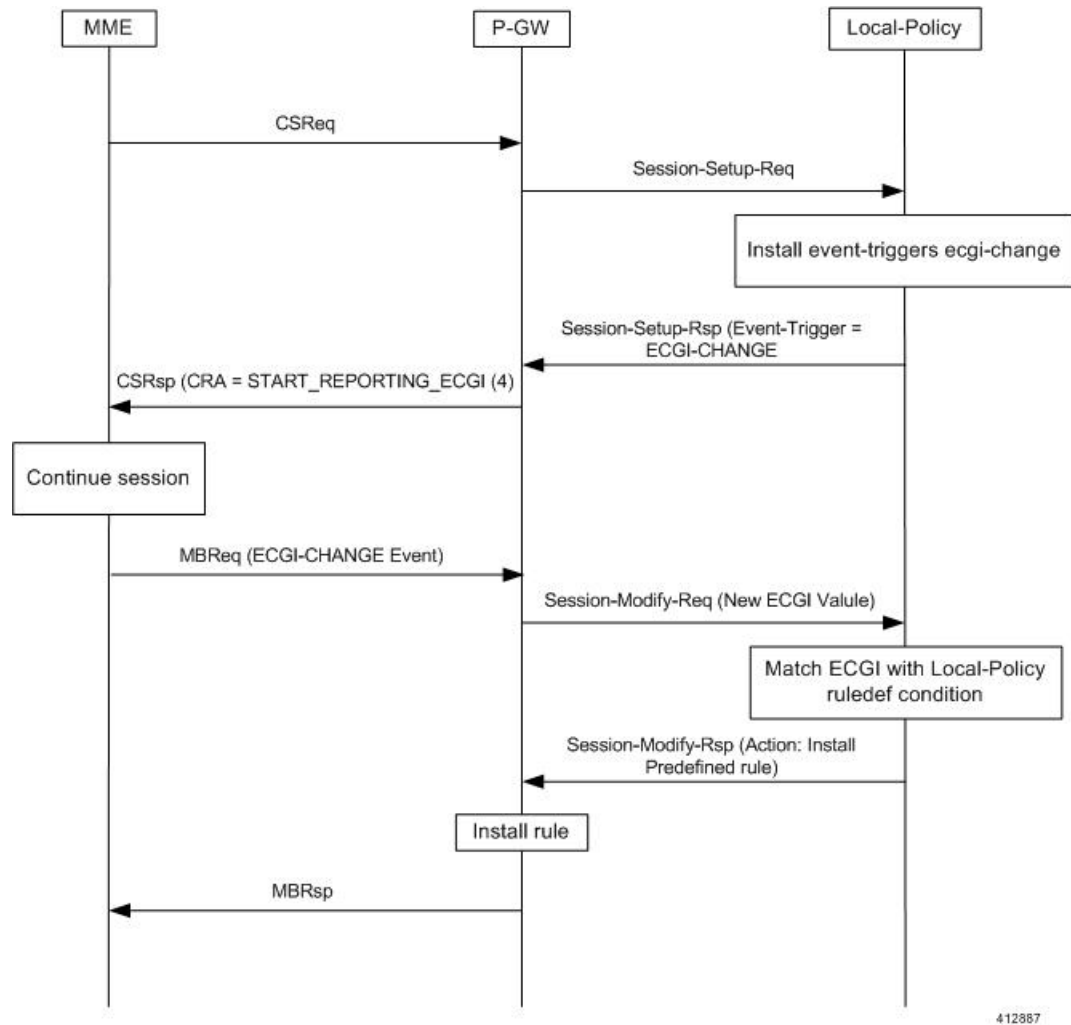

412867

When a new call is established the ECGI-CHANGE event trigger is sent from Local-Policy. P-GW requests the MME for ECGI reporting by sending CRA of 4 in Create Session Response (CSRsp). MME informs the P-GW of ECGI Change through Change Notification request/Modify Bearer Request (MBReq). Local-Policy configuration at P-GW will handle the ECGI-CHANGE event and take appropriate action based on the ECGI group to which the new ECGI belongs. One action could be to activate a certain redirect rule when ECGI belongs to a certain group, and other action could be to enable a wildcard rule for any other ECGI.

Limitations

This section identifies the known limitations of this feature.

- ECGI Change detection and triggering is a pre-requisite for this feature.
- This feature is supported for Local-Policy-only (lp-only) mode wherein, all requests and responses within a particular APN directly go to Local-Policy without contacting PCRF. That is, this feature does not work in Local-Policy fallback mode and dual mode wherein both PCRF and Local-Policy co-exist.

Configuring Location Based Local Policy Rule Enforcement Feature

This section provides the configuration of parameters within Local-Policy to enable rule enforcement based on ECGI-Change event notification.

Configuring ECGI Change Trigger

Use the following configuration to install ECGI-Change trigger from local-policy.

```
configure
  local-policy-service service_name
    actiondef actiondef_name
      action priority priority event-triggers ecgi-change
    exit
  eventbase default
    rule priority priority event new-call ruledef ruledef_name actiondef
actiondef_name [ continue ]
  end
```

Notes:

- **priority** *priority*: Specifies a priority for the specified action. *priority* must be unique and an integer from 1 to 2048.
- **ecgi-change**: This keyword specifies to install ECGI-CHANGE event trigger. If enabled, ECGI-CHANGE event trigger is sent from local-policy.
- This CLI command is configured in local-policy if operator wants to enable ECGI-Change notification in MME by sending a CRA value.

Applying Rules for ECGI-Change Event

Use the following configuration to enable ECGI Change detection and take specific action for ECGI-CHANGE event reported by MME.

```
configure
  local-policy-service service_name
    eventbase eventbase_name
      rule priority priority event ecgi-change ruledef ruledef_name
actiondef actiondef_name [ continue ]
  end
```

Notes:

- **priority** *priority*: Specifies a priority for the specified rule. *priority* must be unique and an integer from 1 to 2048.
- **ruledef** *ruledef_name*: Associates the rule with a specific ruledef. *ruledef_name* must be an existing ruledef within this local QoS policy service.
- **actiondef** *actiondef_name*: Associates the rule with a specific actiondef. *actiondef_name* must be an existing actiondef within this local QoS policy service expressed as an alphanumeric string of 1 through 63 characters.
- **ecgi-change**: Enables a new event to detect ECGI-CHANGE and applies specific action for the ECGI-CHANGE event as defined in actiondef configuration.

- **continue**: Subsequent rules are also matched; otherwise, rule evaluation is terminated on first match.

Enforcing Local Policy Rule based on ECGI Value

Use the following configuration to apply rules based on the ECGI value received in ECGI-Change event notification by MME.

```
configure
  local-policy-service service_name
    ruledef ruledef_name
      condition priority priority ecgi mcc mcc_num mnc mnc_num eci { eq |
ge | gt | le | lt | match | ne | nomatch } regex | string_value | int_value |
set }
    end
```

Notes:

- **priority priority**: Specifies a priority for the specified condition. *priority* must be unique and an integer from 1 to 2048.
- **ecgi mcc mcc_num mnc mnc_num eci**: Configures ECGI with values for MCC, MNC and ECI.
 - **mcc mcc_num** : MCC is a three digit number between 001 to 999. It is a string of size 3 to 3.
 - **mnc mnc_num** : MNC is a two/three digit number between 01 to 999. It is a string of size 2 to 3.
 - **eci**: ECI is a hexadecimal number between 0x1 to 0xfffffff. It is a string of size 1 to 7.
- This CLI command is configured in local-policy if operator wants to take specific action based on certain ECGI value received in ECGI-Change event notification by MME.

Verifying the Location Based LP Rule Enforcement Configuration

Use the following command to verify the configuration of this feature.

```
show configuration context
```



Important This feature is supported for Local-Policy-only mode wherein, all requests and responses within a particular APN directly go to Local-Policy without contacting PCRF.

Here is an example configuration for this feature.

```
configure
  context source
    apn corporate-apn
    ims-auth-service LocalPolicy_1
  exit
exit
end

configure
  local-policy-service LocalPolicy_1
  ruledef any-imsi
    condition priority 1 imsi match *
```

```

exit
ruledef ecgi-group
    condition priority 1 ecgi mcc 123 mnc 456 eci eq ffff
exit
actiondef ecgi-trigger
    action priority 1 event-triggers ecgi-change
exit
actiondef ecgi-redirect-rule
    action priority 1 activate-rule name rule-1
exit
eventbase default
    rule priority 1 event new-call ruledef any-imsi actiondef ecgi-trigger

    rule priority 2 event ecgi-change ruledef ecgi-group actiondef
ecgi-redirect-rule
    rule priority 3 event location-change ruledef ecgi-group actiondef
ecgi-redirect-rule
    exit
exit
end

```

Monitoring and Troubleshooting the Location Based LP Rule Enforcement Feature

This section provides information regarding show commands and/or their outputs in support of the Location Based Local Policy Rule Enforcement feature.

Use the following CLI commands to troubleshoot if any issue is encountered with this feature.

```

show configuration context
logging filter active facility local-policy level debug
show local-policy statistics
show active-charging sessions full

```

show local-policy statistics summary

The following statistics are added to the output of this show command to support the ECGI-CHANGE event trigger installation:

- Event Statistics:
 - ECGI Change - Displays the number of ECGI-CHANGE event triggers that has been received by Local-Policy.
- Variable Matching Statistics
 - ECGI - Displays the number of times the ECGI is matched and the specific action is applied based on the event.

Gx Support for GTP based S2a/S2b

The Gx support for GTP based S2a/S2 interface is extended to all customers for WiFi integration in P-GW. This implementation is in compliance with standard Rel.8 Non-3GPP specification part of 29.212, along with C3-101419 C3-110338 C3-110225 C3-120852 C3-130321 C3-131222 CRs from Rel.10/Rel.11.

As part of this enhancement, the following changes are introduced:

- AVP support for TWAN ID is provided
- TWAN-ID is added to r8-gx-standard dictionary

Gx-based Virtual APN Selection

This section describes the overview and implementation of Gx based Virtual APN Selection feature.

This section discusses the following topics for this feature:

- [Feature Description, on page 585](#)
- [Configuring Gx based Virtual APN Selection Feature , on page 586](#)
- [Monitoring and Troubleshooting the Gx based Virtual APN Selection, on page 586](#)

Feature Description

Overview

The current implementation supports Virtual APN (VAPN) Selection through RADIUS or local configuration. The ASR 5500 uses PCRF and Gx interface for Virtual APN selection to achieve signaling reduction.

A new supported feature "**virtual-apn**" with feature bit set to 4 is added to the IMSA configuration. This configuration enables Gx based Virtual APN Selection feature for a given IMS authorization service. When this configuration is enabled at P-GW/GGSN, then P-GW/GGSN advertises this feature to PCRF through the Supported-Features AVP in CCR-I. When the VAPN is selected, then the PCRF rejects the CCR-I message with the Experimental-Result-Code AVP set to 5999 (DIAMETER_GX_APN_CHANGE), and sends a new APN through the Called-Station-Id AVP in CCA-I message. The existing call is then disconnected and reestablished with the new virtual APN. Note that the Experimental Result Code 5999 will have the Cisco Vendor ID.



Important Enabling this feature might have CPU impact (depending on the number of calls using this feature).

License Requirements

This feature requires a valid license to be installed prior to configuring this feature. Contact your Cisco account representative for detailed information on specific licensing requirements. For information on installing and verifying licenses, refer to the *Managing License Keys* section of the *Software Management Operations* chapter in the *System Administration Guide*.

Limitations

The following are the limitations of this feature:

- Virtual APN supported feature negotiation, Experimental Result Code (5999), Called-Station-Id AVP should be received to establish the call with new virtual APN. When any one of conditions is not met then the call will be terminated.
- Failure-handling will not be taken into account for 5999 result-code when received in the CCA-I message.
- When the Experimental Result Code 5999 is received in the CCA-U then failure-handling action will be taken.
- If the Called-Station-Id AVP is received in CCA-U or CCA-T, then the AVP will be ignored.
- If virtual-apn is received in local-policy initiated initial message then the call will be terminated.
- When PCRF repeatedly sends the same virtual-apn, then the call will be terminated.

Configuring Gx based Virtual APN Selection Feature

The following section provides the configuration commands to enable the Gx based Virtual APN Selection.

```
configure
  context context_name
    ims-auth-service service_name
      policy-control
        diameter encode-supported-features virtual-apn
      end
```

Notes:

- **virtual-apn**: This keyword enables configuration of Gx-based Virtual APN Selection feature. By default, this feature is disabled.
- This keyword is license dependent. For more information, contact your Cisco account representative.

Verifying the Gx based Virtual APN Configuration

Use the following command in Exec mode to display whether the Gx based Virtual APN Selection feature is configured as part of the Supported-Features AVP.

```
show ims-authorization sessions full all
```

The "Negotiated Supported Features" field in this show command output displays the configuration status. This supported feature is displayed only when the feature license is configured.

Monitoring and Troubleshooting the Gx based Virtual APN Selection

This section provides information regarding show commands and/or their outputs in support of this feature.

show ims-authorization policy-control statistics

The following field has been added to the output of this show command to track the number of times the PCRF sends the Diameter Experimental Result Code (5999) when a new virtual APN is selected.

- **Gx APN Change**

For descriptions of this statistics, see the *Statistics and Counters Reference* guide.

Debugging Statistics

Use the following command to debug the Gx based Virtual APN calls.

```
show session subsystem facility sessmgr debug-info
```

This command displays the detailed statistics associated with the Gx-based VAPN feature. For example, number of Gx VAPN received, number of AAAMGR/SGX/DHCP messages after enabling Gx VAPN, and Gx VAPN calls setup time.

Bulk Statistics for Gx based Virtual APN Selection Feature

IMSA Schema

The following new bulk statistic variable is added to the IMSA schema to track the number of times the PCRF sends the Diameter Experimental Result Code (5999) when a new virtual APN is selected.

- `dpca-expres-gx-apn-change`

For descriptions of this variable, see the *Statistics and Counters Reference* guide.

System Schema

The following new disconnect reason is added to the System schema to track the number of times a P-GW/GGSN/SAEGW session was disconnected due to validation failure of virtual APN received from PCRF.

- `gx-vapn-selection-failed (618)`

For descriptions of this variable, see the *Statistics and Counters Reference* guide.

Graceful Handling of RAR from Different Peers

In the StarOS Gx architecture, every Diameter session is associated with a primary and secondary peer when the host selection is configured at the IMSA service.

In certain networks where PCRF and PCEF are connected through multiple DRAs the PCRF may select the DRA in a round-robin fashion and the RAR for a session may come from a peer which is neither Primary nor Secondary. In order to handle such a scenario, the ability to respond to the RAR received from a non-primary and non-secondary peer was added. In this case, the RAR is answered via the peer from which RAR was received. However any future signaling for the session will still occur via the previously communicating peer. If the RAR is received via the secondary peer, the host-switch occurs and the behavior remains unchanged. In order to be able to process the RAR from a third peer, that peer must be configured in the Diameter endpoint configuration. Further, this issue is seen only when host select is configured at IMSA service. When the host selection happens at endpoint level, this issue is not seen.

Assume there are three DRAs and they are configured as shown in the sample configuration below:

```
configure
  context test
    diameter endpoint Gx
      ...
      peer DRA1 realm realmName address 192.168.23.3
      peer DRA2 realm realmName address 192.168.23.3 port 3869
      peer DRA3 realm realmName address 192.168.23.3 port 3870
    exit
```

```

ims-auth-service imsa-Gx
  policy-control
    diameter host-select row-precedence 1 table 1 host DRA1
secondary host DRA2
end

```

Without the feature, when RAR is received from DRA3, it is rejected. With the feature enabled, RAR from DRA3 is responded via DRA3 only and Peer switch will not occur in this case and subsequent messaging will be sent through DRA1 or DRA2 if any prior peer switch had happened.

Limitations

This section identifies the limitations for this feature.

- RAR will be rejected when received from different origin host.
- RAR will be rejected when received from a DRA not configured in Diameter endpoint.

NetLoc Feature Enhancement

This feature adds compliance with 3GPP standard R13 version to the existing NetLoc feature functionality.

Feature Description



Important

This is a license controlled feature. Netloc feature license key is required to be enabled. Contact your Cisco account representative for information on how to obtain a license.

This feature adds compliance with 3GPP standard R13 version to the existing NetLoc feature functionality. Using this NetLoc feature, the IMS network can retrieve location information of the UE from the access or LTE network. This enhances the location related functionality and charging based on the location information.

This feature introduces the following behavior changes:

- Assuming that NetLoc feature is enabled on chassis and Access Network Information (ANI-45) Event trigger is installed, following behavior changes have been introduced:

Table 57: Gx Interface Behavior Change Towards PCRF

PCRF Gx Interface Interaction	Access Side Interaction	ULI & MS TZ Behavior Before 21.1 Release(Standard Gx-R8/Custom15 (AT&T))	ULI & MS TZ Behavior Change(Standard Gx-R8/Custom15 (AT&T))
RAI AVP with '0 - ULI' is received in the charging rule install request.	Create Bearer Response is received with only New ULI parameter.	Create Bearer Response is received with only New ULI parameter.	No change in the behavior.

PCRF Gx Interface Interaction	Access Side Interaction	ULI & MS TZ Behavior Before 21.1 Release(Standard Gx-R8/Custom15 (AT&T))	ULI & MS TZ Behavior Change(Standard Gx-R8/Custom15 (AT&T))
RAI AVP with '0 - ULI' is received in the charging rule install request.	Create Bearer Response is received with No ULI parameter.	Old ULI parameter is sent towards the PCRF in the CCR-U message.	PLMN-id in 3GPP-SGSN-MCC-MNC AVP is sent towards the PCRF.
RAI AVP with '0 - ULI' is received in the charging rule modify request.	Update Bearer Response is received with only New ULI parameter.	New ULI parameter is sent towards the PCRF in the CCR-U message.	No change in the behavior.
RAI AVP with '0 - ULI' is received in the charging rule Modify request.	Update Bearer Response is received with No ULI parameter.	Old ULI parameter is sent towards the PCRF in the CCR-U message.	PLMN-id in 3GPP-SGSN-MCC-MNC AVP is sent towards the PCRF.
RAI AVP with '0 - ULI' is received in the charging rule modify request.	Delete Bearer Response is received with only New ULI parameter and No MS TZ parameter.	New ULI and old MS TZ parameters are sent towards the PCRF in the CCR-U message.	Only New ULI is sent towards the PCRF in the CCR-U message.
RAI AVP with '0 - ULI' is received in the charging rule Modify request.	Delete Bearer Response is received with No ULI parameter and No MS TZ parameter.	Old ULI and old MS TZ parameters are sent towards the PCRF in the CCR-U message.	PLMN-id in the 3GPP-SGSN-MCC-MNC AVP is sent towards the PCRF.
RAI AVP with '1 -MSTZ' is received in the charging rule install request.	Create Bearer Response is received with only new MS TZ parameter.	New MS TZ parameter is sent towards the PCRF in the CCR-U message.	No change in the behavior.
RAI AVP with '1 - MSTZ' is received in the charging rule install request.	Create Bearer Response is received with No MS TZ parameter.	Old MS TZ parameter is sent towards the PCRF in the CCR-U message.	No change in the behavior.
RAI AVP with '1 -MSTZ' is received in the charging rule modify request.	Update Bearer Response is received with only New MS TZ parameter.	New MS TZ parameter is sent towards the PCRF in the CCR-U message.	No change in the behavior.
RAI AVP with '1 -MSTZ' is received in the charging rule Modify request.	Update Bearer Response is received with No MS TZ parameter.	Old MS TZ parameter is sent towards the PCRF in the CCR-U message.	No change in the behavior.

PCRF Gx Interface Interaction	Access Side Interaction	ULI & MS TZ Behavior Before 21.1 Release(Standard Gx-R8/Custom15(AT&T))	ULI & MS TZ Behavior Change(Standard Gx-R8/Custom15(AT&T))
RAI AVP with '1 -MSTZ' is received in the charging rule modify request.	Delete Bearer Response is received with only New MS TZ parameter.	Old ULI and New MS TZ parameters are sent towards the PCRF in the CCR-U message.	Only New MS TZ is sent towards the PCRF in the CCR-U message.
RAI AVP with '1 -MSTZ' is received in the charging rule Modify request.	Delete Bearer Response is received with No MS TZ parameter.	New ULI and old MS TZ parameters are sent towards the PCRF in the CCR-U message.	Only old MS TZ is sent towards the PCRF.
Nothing is received.	Delete Session Request is received with New ULI and New MS TZ parameters.	New ULI and New MS TZ parameters are sent towards the PCRF in the CCR-T message.	No change in the behavior.
Nothing is received.	Delete Session Request is received with New ULI and No MS TZ parameter.	New ULI and Old MS TZ parameters are sent towards the PCRF in the CCR-T message.	No change in the behavior.
Nothing is received.	Delete Session Request is received with No ULI and No MS TZ parameter.	Old ULI and Old MS TZ parameters are sent towards the PCRF in the CCR-T message.	No change in the behavior.



Important ULI and ULI timestamp is considered as paired. If the ULI timestamp is forwarded, it is forwarded and received with the ULI. If the ULI is received and the ULI timestamp is not received, then that P-GW does not forward the old timestamp.

- Inclusion of AVP support of NETLOC-ACCESS-NOT-SUPPORTED on Gx interface. This inclusion of AVP is based on the below conditions:
 - RAT type is other than E-UTRAN, UTRAN, WCDMA, GPRS, GERAN, and W-LAN
 - IP CAN type is other than 3GPP EPS, GPRS, and non 3GPP EPS
 - Re-Auth-Request is received with Required-Access-Info AVP.
 - NetLoc feature is enabled on the chassis.
 - Event-Trigger ACCESS_NETWORK_INFO_REPORT (45) is installed.

Before Release 21.1 Behavior (Standard Gx-R8/Custom15(AT&T))	New Behavior(Standard Gx-R8/Custom15(AT&T))
Earlier, if IP-CAN type or RAT type was not support NETLOC, P-GW(PCEF) ignored RAI received from the PCRF.	New AVP NetLoc-Access-Support has been added in the Re-Auth-Answer message in the R8-Gx-standard and the Custom15 Gx Dictionary.

• **Table 58: Behavior Change Regarding LastUserLocationInformation AVP and LastMSTimeZone AVP**

P-GW CDR Behavior	Post 21.1 Release, Behavior in Custom 35/Custom 24/Custom 48 Dictionaries	Custom52 Dictionary (standard compliance new dictionary)/ Custom 35 Dictionary (Customer Specific)
ULI is received in Delete Bearer Command/Delete Bearer Request /Delete Session Request.	ULI was not part of P-GW CDR generation.	ULI is recorded as LastUserLocationInformation AVP in the P-GW CDR generation. (AVP is not controlled using the CLI command.)
MS TZ is received in the Delete Bearer Command/Delete Bearer Request /Delete Session Request.	MS TZ was not part of P-GW CDR generation.	MS TZ is recorded as LastMSTimeZone AVP in the P-GW CDR generation. CDR is released as Normal Release. MS TZ is not detected in this case as full trigger and does not release extra CDR with MS TZ changes cause. AVP is not controlled using the CLI command.
S-GW CDR behavior	Post 21.1 Release behavior in Custom 35/Custom 24 Dictionary	Custom24 Dictionary (standard dictionary)/ Custom 35 Dictionary (AT&T)
ULI is received in Delete Bearer Command/Delete Bearer Request /Delete Session Request.	ULI was not part of CDR generation.	ULI is Recorded as LastUserLocationInformation AVP in the S-GW CDR generation. The attribute is controlled using a CLI command.
MS TZ is received in Delete Bearer Command/Delete Bearer Request /Delete Session Request.	MS TZ was not part of CDR generation.	MS TZ is Recorded as LastMSTimeZone AVP in S-GW CDR generation. The attribute is controlled using a CLI command. CDR is released as Normal Release. MS TZ is not detected in this case as full trigger and does not release extra CDR with MS TZ changes cause.

Limitations

1. This feature enhancement is applicable only for S-GW, P-GW, and SAEGW. For GGSN ad SGSN, there is no change in the behavior of the NetLoc feature.
2. The attributes **Last-MS-Timezone** and **Last ULI attributes** have been added in the dictionaries custom24 and custom35 for S-GW CDR generation only.

3. The keywords **last-ms-timezone** and **last-uli** added to the CLI command **gtp attribute** are applicable and limited to only S-GW CDR generation.
4. **Last-MS-Timezone** and **Last ULI attributes** added in dictionary custom35 (customer specific dictionary) and custom52 (3GPP R13 standard compliance) are applicable and limited to P-GW CDR generation only. These attributes are not CLI controlled.

Command Changes

gtp attribute

This CLI command allows the specification of the optional attributes to be present in the Call Detail Records (CDRs) that the GPRS/PDN/UMTS access gateway generates. It also defines that how the information is presented in CDRs by encoding the attribute field values. The keywords **last-ms-timezone** and **last-uli** have been added to this CLI command to control attribute while CDR generation.



Important The keywords added are applicable only for S-GW CDR. They are not applicable for P-GW CDR.

```

configure
  context <context_name>
    gtp group group_name
      gtp attribute { last-ms-timezone | last-uli | .. }
      [no | default ] gtp attribute { last-ms-timezone | last-uli |
.. }
    end

```

Notes:

- **no:** Removes the configured GTPP attributes from the CDRs.
- **default:** Sets the default GTPP attributes in the generated CDRs. It also sets the default presentation of attribute values in generated CDRs.
- **last-ms-timezone:** Sets the "Last MS-Timezone" in the CDR field. This option would be disabled when the default option is used.
- **last-uli:** Sets the "Last ULI" in the CDR field. This option would be disabled when the default option is used.

Performance Indicator Changes

show configuration

This command has been modified to display the following output:

- Last-MS-Timezone present
- Last-User Location Information present

show gtp group name group_name

This command has been modified to display the following output:

```
Last-MS-Timezone present: yes
Last-User Location Information present:
yes
```

RAN-NAS Cause Code Feature Enhancement

This chapter describes the RAN-NAS Cause Code Feature Enhancement.

Feature Description



Important This is a license controlled feature. You must enable the existing license of NPLI. Contact your Cisco account representative for information on how to obtain a license.

This feature introduces support for 3GPP RAN/NAS cause code IE for "Failed Create Bearer Response", "Failed Updated Bearer Response", and "Delete Bearer Response" at the Gx interface, the P-GW, and S-GW CDRs. This will enable the operator to get detailed RAN/NAS release cause code information from the access network. RAN/NAS cause can be received from the access side in either of the following messages:

- Failed Create Bearer Response
- Failed Update Bearer Response
- Delete Session Request
- Delete Bearer Response
- Delete Bearer Command

This support of 3GPP Release 12 RAN/NAS cause IE on the S4, S11, S5, and S8 interfaces exists for "Delete Session Request" and "Delete Bearer" command through private extension as well as Standard IE for customer specific dictionaries Gx- dpca-custom15 and Gz-Custom35.

However, RAN/NAS cause received in the "ERAB creation Failure", "ERAB modification Failure", and "ERAB release indication" messages were not processed at the S-GW and P-GW. Hence, it was also not forwarded to the PCRF by P-GW neither populated in the P-GW and S-GW CDRs. With this feature enhancement, support has been added to process the RAN/NAS cause codes at the S-GW (S4,S11 interface) and P-GW (S5,S8 interface) for the "Create bearer response", "Update bearer response", and "Delete bearer response". Also, RAN/NAS cause codes will be forwarded to the PCRF by the P-GW and will be populated in the P-GW and S-GW CDRs.

There is no requirement to add the support for the 3GPP Release 12 RAN/NAS cause IE received in the private extension for "Create Bearer Response", "Update Bearer Response", and "Delete Bearer Response". Private extension support for 3GPP Release 12 cause code IE in "Delete Session Request" and "Delete Bearer Command" will continue to be supported.

This feature enhancement introduces the following RAN/NAS cause IE behavior changes at the Gx interface for dpca-custom15 dictionary and at Gz interface for custom35 dictionary.

Table 59: Gx Interface Requirements for RAN/NAS Cause

Message	GTP Cause	Gx Message Carrying RAN-NAS Cause Information
Create Bearer Response	Accepted	RAN/NAS cause is not expected as per 29.274 Table 7.2.4-2. So if it is received, it is ignored and is not forwarded to the PCRF.
	Temporarily rejected due to HO in progress.	RAN/NAS cause with this GTP cause is not applicable as per 29.274 Table C.4. So if received it is ignored and is not forwarded to the PCRF.
	Other GTP Causes	CCR-U
Update Bearer Response	Accepted	RAN/NAS cause is not expected as per 29.274 Table 7.2.16-2. So if it is received, it is ignored and is not forwarded to the PCRF.
	No Resources	CCR-U
	Available	Important If the UE-initiated (MBC) bearer modification fails with the GTP cause "NO RESOURCES AVAILABLE", then P-GW deletes the entire PDN session. In this case, RAN-NAS cause information is forwarded as part of the CCR-T message.
	Context Not Found	If the update bearer response is received with the message level cause as "CONTEXT NOT FOUND", which leads to the PDN deletion, then the RAN-NAS cause information is forwarded as part of the CCR-T message.
	Temporarily rejected due to HO in progress.	RAN/NAS cause with this GTP cause is not applicable as per 29.274 Table C.4. So if this cause is received, it is ignored and is not forwarded to the PCRF.
	Other GTP Causes	CCR-U

Message	GTP Cause	Gx Message Carrying RAN-NAS Cause Information
Delete Bearer Response	Temporarily rejected due to HO in progress	<p>RAN/NAS cause with this GTP cause is not applicable as per 29.274 Table C.4. So if this cause is received, it is ignored and is not forwarded to the PCRF.</p> <p>Important As per existing design of S-GW, if "Delete Bearer Response" is received with GTP cause "Temporarily rejected due to handover/ TAU/ RAU procedure in progress" it changes GTP cause to "Request Accepted" and forwards it to the P-GW. In this case, if RAN/NAS cause is received in the "Delete Bearer Response", S-GW will forward it to the P-GW. And at the P-GW since "Delete Bearer Response" is received with the GTP cause "Request Accepted" hence RAN/NAS cause is forwarded to the PCRF and populated in the P-GW CDR. This behavior will be seen for SAEGW and S-GW + P-GW combination call.</p>
	Accepted / Other GTP CCR-UCauses	<p>Important If RAN/NAS cause is received in the delete bearer response that is initiated by the network through RAR/CCA-U, then P-GW will not send CCR-U to the PCRF to report the RAN/NAS cause.</p> <p>This support is introduced in 29.212 release 13.5 with "Enhance RAN/NAS" feature".</p>

Table 60: Gz Interface Requirements for RAN/NAS Cause

Message	S-GW CDR	P-GW CDR
Delete Session Request	Yes	Yes
Delete Bearer Command	Yes	Yes NOTE: RAN/NAS cause if received in delete bearer response will overwrite the RAN/NAS cause received in delete bearer command
Failed Create Bearer Response	No	No
Failed Update Bearer Response	No	No
Delete Bearer Response	No	Yes

Limitations

Following are the limitations of this feature:

- Support of RAN/NAS cause over S2a and S2b interfaces is not supported.
- Support of RAN/NAS cause information has not been added for standard Gx and Gz dictionaries.
- P-GW processes first two RAN/NAS cause IE (max one RAN and max one NAS) information received from the GTP interface. For example, if the access network misbehaves and sends RAN/NAS cause list with two NAS and one RAN then only first two causes are considered and validated. In this case, these are two NAS causes, only first NAS cause will be populated at the Gx interface and in the CDRs as only one NAS is allowed.
- As per spec 32.251 Table 5.2.3.4.1.1 and Table 5.2.3.4.2.1, there is no trigger to generate the S-GW CDRs and P-GW CDRs for failed create bearer response and failed update bearer response. Hence, RAN/NAS cause received in "Failed Create Bearer" response and "Failed Update Bearer" response will not be sent to the Gz interface.
- In "Delete Bearer" scenario, S-GW CDRs are generated immediately after receiving "Delete Bearer" request. Hence, RAN/NAS cause received in the "Delete Bearer" response is not populated in the S-GW CDRs.
- If RAN/NAS cause is received in the "Delete Bearer" response that is initiated by the network through RAR/CCA-U, P-GW will not send CCR-U to the PCRF to report the RAN/NAS cause. This support is introduced in spec 29.212 release 13.5 with "Enhance RAN/NAS" feature".
- If the RAN-NAS-Cause feature is supported, only RAN/NAS cause is forwarded to PCRF . ANI information will be forwarded only when NetLoc feature is enabled. Below table describes various scenarios,

Scenario	RAN/NAS Cause Behavior	ANI Behavior
IP-CAN Bearer Termination	If the RAN-NAS-Cause feature is supported (If Netloc-ran-nas-cause CLI is configured and Supported-Features = RAN-NAS-CAUSE was asserted in the Gx CCR-I/CCA-I), PCEF will include the received RAN cause and/or the NAS cause due to bearer termination, in the RAN-NAS-Release-Cause AVP included in the Charging-Rule-Report AVP.	ANI information received during bearer termination is populated in the CCR-U, if Required-Access-Info was asserted when one or more of the failed charging rules installation request was received in CCA-U/RAR (If Netloc CLI is configured and Supported-Features = Netloc was asserted in Gx CCR-I/CCA-I).
IP-CAN Session Termination	If the RAN-NAS-Cause feature is supported (If Netloc-ran-nas-cause CLI is configured and Supported-Features = RAN-NAS-CAUSE was asserted in the Gx CCR-I/CCA-I), PCEF will include the received RAN cause and/or the NAS cause due to session termination, in the RAN-NAS-Release-Cause AVP at the command level.	ANI information received during session termination is populated in CCR-T, if Required-Access-Info was asserted when one or more of the failed charging rules installation request was received in the CCA-U/RAR (If Netloc CLI is configured and Supported-Features = Netloc was asserted in the Gx CCR-I/CCA-I).

Scenario	RAN/NAS Cause Behavior	ANI Behavior
PCC Rule Error Handling	If the RAN-NAS-Cause feature is supported (If Netloc-ran-nas-cause CLI is configured and Supported-Features = RAN-NAS-CAUSE was asserted in Gx CCR-I/CCA-I), PCEF will include the received RAN cause and/or the NAS cause due to rule installation/ activation/ modification failure, in the RAN-NAS-Release-Cause AVP included in the Charging-Rule-Report AVP.	ANI information received due to rule installation/activation/modification failure is populated in CCR-U, if Required-Access-Info was asserted when one or more of the failed charging rules installation request was received in CCA-U/RAR (If Netloc CLI is configured and Supported-Features = Netloc was asserted in the Gx CCR-I/CCA-I).

Command Changes

diameter encode-supported-features netloc netloc-ran-nas-cause

The behavior of this CLI command has been modified in this feature enhancement.

Previous Behavior: To enable the RAN/NAS Cause feature, it was mandatory to enable the NetLoc feature. For this, it was mandatory to configure the **netloc** keyword in the CLI command **diameter encode-supported-features netloc netloc-ran-nas-cause** .

New Behavior: Now, you can enable the RAN/NAS feature without configuring the NetLoc feature. This implied that it is not mandatory to configure the **netloc** keyword in the CLI command **diameter encode-supported-features netloc netloc-ran-nas-cause** .

```
configure > context context_name > ims-auth-service service_name > policy-control
diameter encode-supported-features netloc netloc-ran-nas-cause
```

Session Disconnect During Diamproxy-Session ID Mismatch

This section describes how to clear the subscriber sessions that are impacted due to the mismatch in Diamproxy grouping information and Session ID.

This section discusses the following topics for this feature:

- [Feature Description, on page 597](#)
- [Configuring System to Delete Diamproxy-Session ID Mismatched Sessions, on page 598](#)
- [Monitoring and Troubleshooting the Mismatched Session Deletion Feature, on page 599](#)

Feature Description

During rapid back-to-back ICSR switchovers or extensive multiple process failures, the Diameter proxy-Session manager mapping information is not preserved across ICSR pairs. This mismatch in the Diameter proxy-Session ID results in rejection of RAR with 5002 - DIAMETER_UNKNOWN_SESSION_ID cause code. This behavior impacts the VoLTE call setup procedure. Hence, this feature is introduced to clear the subscriber sessions that are impacted due to the mismatch in the Diameter proxy-session manager mapping. New CLI configuration

is provided to control the behavior and new bulk statistic counter is supported to report the Diamproxy-Session ID mismatch.

The bulk statistic counter will be incremented only when session is cleared upon receiving RAR message with 5002 result code and detecting session-ID Diamproxy mapping mismatch. A Delete Bearer Request is sent to S-GW with a Reactivation Requested as the cause code while suppressing the CCR-T from being sent to PCRF. So, the subscriber reattaches immediately without impacting the subsequent VoLTE calls, encountering only one failure instead of manual intervention.



Important This enhancement is applicable only to IMS PDN so that there is a limit of one failure when encountering this situation instead of manual intervention. This is applicable to only the Gx RARs.

Configuring System to Delete Diamproxy-Session ID Mismatched Sessions

The following section provides the configuration commands to enable the system to clear the subscriber sessions that are impacted due to the mismatch in Diamproxy grouping information and Session ID.

Clearing Mismatched Subscriber Sessions

Use the following configuration commands to configure the system to disconnect the subscriber sessions based on signaling trigger when session ID and Diamproxy mismatch is identified.

```
configure
  context context_name
    ims-auth-service service_name
      policy-control
        diameter clear-session sessid-mismatch
  end
```

- **sessid-mismatch**: Clears the session with mismatched session ID. This CLI configuration is optional.
- The default configuration is **no diameter clear-session**. By default, the sessions will not be cleared.

Verifying the Configuration to Delete Mismatched Sessions

Use the following command to verify the configuration status of this feature.

```
show ims-authorization service name service_name
```

service_name must be the name of the IMS Authorization service configured for IMS authentication.

This command displays all the configurations that are enabled within the specified IMS authorization service. The "Session-Id Mismatch Clear Session" field can be used to determine whether this feature is enabled or disabled.

```
[local]st40# show ims-authorization service name service1
Context: test
IMS Authorization Service name: service1
Service State: Enabled
Service Mode: Single Interface Policy and Charging
...
Diameter Policy Control:
Endpoint: gx
Origin-Realm: xyz.com
Dictionary: standard
```

```

Supported Features:
  3gpp-r9
...
Host Selection: Table: 1 Algorithm: Round-Robin
Host Reselection Subscriber Limit: Not Enabled
Host Reselection Interval: Not Enabled
Sgsn Change Reporting: Not Enabled
Session-Id Mismatch Clear Session: Enabled
3GPP R9 Flow Direction Compliance: Not Enabled
Host Selection Table[1]: 1 Row(s)
Precedence: 1
...

```

Monitoring and Troubleshooting the Mismatched Session Deletion Feature

This section provides information regarding show commands and/or their outputs in support of this feature.

The following operations should be performed for any failure related to this feature:

- Verify if the feature is enabled using **show ims-authorization service name** <service_name> CLI command. If not enabled, configure the **diameter clear-session sessid-mismatch** CLI command and check if it works.
- Collect the output of **show ims-authorization policy-control statistics debug-info** and **show diameter statistics proxy debug-info** commands and analyze the debug statistics.
- Check the system logs that are reported while deleting the affected sessions. For further analysis, contact Cisco account representative.

show ims-authorization service name

A new field "Session-Id Mismatch Clear Session" is added to the output of this show command to indicate whether this feature is enabled or disabled within the specified IMS authorization service.

IMSA Schema

The following bulk statistic variable is added to this schema to report the Diamproxy-Session ID mismatch.

- **dpcarar-dp-mismatch** - This counter displays the total number of sessions cleared while receiving RAR because of session-ID Diamproxy mapping mismatch.

Support for Negotiating Mission Critical QCI

This section describes the overview and implementation of the Mission Critical QCI Negotiation feature.

This section includes the following topics:

- [Feature Description, on page 600](#)
- [Configuring DPCA for Negotiating Mission Critical QCI, on page 600](#)
- [Monitoring and Troubleshooting the Mission Critical QCI, on page 601](#)

Feature Description

To support Mission Critical (MC) Push to Talk (PTT) services, a new set of standardized QoS Class Identifiers (QCIs) (65, 66, 69, 70) have been introduced. These are 65-66 (GBR) and 69-70 (non-GBR) network-initiated QCIs defined in 3GPP TS 23.203 v13.6.0 and 3GPP TS 23.401 v13.5.0 specifications. These QCIs are used for Premium Mobile Broadband (PMB)/Public Safety solutions.



Important The MC-PTT QCI feature requires Wireless Priority Service (WPS) license to be configured. For more information, contact Cisco account representative.

Previous Behavior: The gateway accepted only standard QCIs (1-9) and operator defined QCIs (128-254). If the PCRF sends QCIs with values between 10 and 127, then the gateway rejects the request. MC QCI support was not negotiated with PCRF.

New Behavior: PCRF accepts the new standardized QCI values 69 and 70 for default bearer creation and 65, 66, 69 and 70 for dedicated bearer creation.

For this functionality to work, a new configurable attribute, **mission-critical-qcis**, is introduced under the **diameter encode-supported-features** CLI command. When this CLI option is enabled, the gateway allows configuring MC QCIs as a supported feature and then negotiates the MC-PTT QCI feature with PCRF through Supported-Features AVP.

The gateway rejects the session create request with MC-PTT QCIs when the WPS license is not enabled and Diameter is not configured to negotiate MC-PTT QCI feature, which is part of Supported Feature bit.

For more information on this feature and associated configurations, refer to *P-GW Enhancements for 21.0* section in the *Release Change Reference* guide.

Configuring DPCA for Negotiating Mission Critical QCIs

The following section provides the configuration commands to enable support for MC-PTT QCI feature.

Enabling Mission Critical QCI Feature

Use the following configuration commands to enable MC-PTT QCI feature.

```
configure
  context context_name
    ims-auth-service service_name
      policy-control
        diameter encode-supported-features mission-critical-qcis
      end
    end
```

Notes:

- **mission-critical-qcis**: This keyword enables MC-PTT QCI feature. By default, this feature will not be enabled.
- This keyword can be enabled only if the WPS license is configured. For more information, contact your Cisco account representative.
- To disable the negotiation of this feature, the existing **no diameter encode-supported-features** command needs to be configured. On executing this command, none of the configured supported features will be negotiated with PCRF.

Verifying the Mission Critical QCI Feature Configuration

The **show ims-authorization sessions full all** command generates a display that indicates the configuration status of this feature.

The following sample display is only a portion of the output which shows *mission-critical-qcis* among the Negotiated Supported Features.

```
show ims-authorization sessions full all

CallId: 00004e29           Service Name:  ims-ggsn-auth
   IMSI: 123456789012341
   ....

Negotiated Supported Features:
  3gpp-r8
  mission-critical-qcis
Bound PCRF Server: 209.165.200.233
Primary PCRF Server: 209.165.200.233
Secondary PCRF Server: NA
  ....
```

Monitoring and Troubleshooting the Mission Critical QCI

The following section describes commands available to monitor the Mission Critical QCI feature.

Mission Critical QCI Show Command(s) and/or Outputs

show ims-authorization sessions full all

On running the above mentioned show command, statistics similar to the following are displayed and will indicate if the Mission Critical QCI feature is enabled or not.

```
show ims-authorization sessions full all

CallId: 00004e29           Service Name:  ims-ggsn-auth
   IMSI: 123456789012341
   ....

Negotiated Supported Features:
  3gpp-r8
  mission-critical-qcis
  ....
```

HSS and PCRF-based P-CSCF Restoration Support for WLAN

This section describes the overview and implementation of the HSS-based and PCRF-based P-CSCF Restoration feature for WLAN and EPC networks.

This section includes the following topics:

- [Feature Description, on page 602](#)
- [Configuring the HSS/PCRF-based P-CSCF Restoration, on page 603](#)
- [Monitoring and Troubleshooting the HSS/PCRF-based P-CSCF Restoration, on page 604](#)

Feature Description

The P-CSCF restoration procedures were standardized to minimize the time a UE is unreachable for terminating calls after a P-CSCF failure. In compliance with 3GPP standard Release 13, this feature is developed to include the following P-CSCF restoration mechanisms:

- HSS-based P-CSCF Restoration for Trusted/Untrusted WLAN Access (S2a/S2b)
- PCRF-based P-CSCF Restoration for LTE (S5/S8) and Trusted/Untrusted WLAN Access (S2a/S2b)



Important HSS-based P-CSCF Restoration was supported at P-GW for LTE (S5/S8) prior to StarOS release 21.0.

This feature provides support for both basic and extended P-CSCF Restoration procedures.



Important The P-CSCF Restoration is a license-controlled feature. A valid feature license must be installed prior to configuring this feature. Contact your Cisco account representative for more information.

- **HSS-based P-CSCF Restoration for WLAN:**

If the P-CSCF restoration mechanism is supported, gateway indicates the restoration support to AAA server through Feature-List AVP in the Authorization Authentication Request (AAR) message sent over S6b interface. The Feature-List AVP is part of the Supported-Features grouped AVP. The Bit 0 of the Feature-List AVP is used to indicate P-CSCF Restoration support for WLAN.

During the P-CSCF Restoration, 3GPP AAA server, after having checked that the PGW supports the HSS-based P-CSCF restoration for WLAN, sends a P-CSCF restoration indication to the P-GW over S6b in a Re-authorization Request (RAR) command. A new Diameter AVP “**RAR-Flags**” is encoded in the RAR message with the Bit 1 set, would indicate to the gateway that the AAA server requests the execution of HSS-based P-CSCF restoration procedures for WLAN.

The existing CLI command **diameter authentication** under AAA Group configuration is extended to encode P-CSCF Restoration feature as part of Supported-Features AVP in the AAR message.



Important Supported-Features will be sent in every AAR message for RAT type WLAN. Feature negotiation is required in every AAR. ReAuth AAR will also do the feature renegotiation.

- **PCRF-based P-CSCF Restoration:**

PCEF supporting P-CSCF restoration mechanism indicates the restoration support in CCR-I message through the Supported-Features AVP. The 24th Bit of the Supported-Feature-List AVP indicates whether this mechanism is supported or not.

The existing CLI command **diameter encode-supported-features** in Policy Control configuration is extended to allow the negotiation of P-CSCF Restoration feature support with PCRF. A new Diameter AVP “**PCSCF-Restoration-Indication**” is introduced to indicate to PCEF that a P-CSCF Restoration is requested. This is achieved by setting AVP value to 0.

Supported-Features AVP is negotiated in CCR-I of all access types (eHRPD, P-GW, GGSN); however, Restoration trigger, if received, is ignored in eHRPD and GGSN.

Limitations

- As per the 3GPP standard specification, if S6b re-authorization request is used for P-CSCF Restoration for WLAN, then for extended P-CSCF Restoration the gateway may send authorization request with only mandatory AVPs. However, in the current implementation, ReAuth used for extended P-CSCF Restoration is a common authorization request of normal ReAuth. It will contain all the AVP of ReAuthorization AAR.

For more information on this feature and associated configurations, refer to *P-GW Enhancements for 21.0* and *SAEGW Enhancements for 21.0* section in the *Release Change Reference* guide.

Configuring the HSS/PCRF-based P-CSCF Restoration

The following section provides the configuration commands to enable support for HSS-based and PCRF-based P-CSCF Restoration feature.

Enabling P-CSCF Restoration Indication on S6b AAA interface

Use the following configuration commands for encoding Supported-Features AVP in the AAR message sent to AAA server via S6b interface.

```
configure
  context context_name
    aaa group group_name
      diameter authentication encode-supported-features
pcscf-restoration-indication
end
```

Notes:

- **encode-supported-features**: Encodes Supported-Features AVP.
- **pcscf-restoration-indication**: Enables the P-CSCF Restoration Indication feature.
- **default encode-supported-features**: Configures the default setting, that is not to send the Supported-Features AVP in AAR message.
- **no encode-supported-features**: Disables the CLI command to not send the Supported-Features AVP.
- The **pcscf-restoration-indication** keyword is license dependent. For more information, contact your Cisco account representative.

Enabling P-CSCF Restoration Indication on Gx interface

Use the following configuration to enable P-CSCF Restoration Indication feature on Gx interface.

```
configure
  context context_name
    ims-auth-service service_name
      policy-control
        diameter encode-supported-features pcscf-restoration-ind
end
```

Notes:

- **pcscf-restoration-ind**: Enables the P-CSCF Restoration Indication feature. This keyword is license dependent. For more information, contact your Cisco account representative. By default, this feature is disabled.
- **default encode-supported-features**: The default configuration is to remove/reset the supported features.
- **no encode-supported-features**: Removes the previously configured supported features.

Verifying the HSS/PCRF-based P-CSCF Restoration

show ims-authorization sessions full all

This command generates a display that indicates the negotiation status of this feature.

The following sample display is only a portion of the output which shows **pcscf-restoration-ind** among the Negotiated Supported Features.

```
show ims-authorization sessions full all

CallId: 00004e22          Service Name:  imsa-Gx
   IMSI: 123456789012341
   ....
Negotiated Supported Features:
  3gpp-r8
  pcscf-restoration-ind
  ....
```

show aaa group all

This show command displays **pcscf-restoration-ind** as part of Supported-Features, if this feature is configured under AAA group.

```
show aaa group all
Group name:  default
Context:    local

Diameter config:
Authentication:
....
Supported-Features:  pcscf-restoration-ind
....
```

Monitoring and Troubleshooting the HSS/PCRF-based P-CSCF Restoration

This section provides information regarding show commands and/or their outputs in support of this feature.

The following operations can be performed for troubleshooting any failure related to this feature:

- Verify if the feature is enabled using **show ims-authorization sessions full all** and **show aaa group all** CLI commands. If not enabled, configure the required CLI commands both under Policy Control and AAA group configuration and check if it works.
- Execute **monitor protocol** command and check if the support for P-CSCF Restoration feature is negotiated in CCR-I and AAR messages. If not, enable the respective CLI commands for this feature to work.
- If the failure is still observed, obtain the following information and contact Cisco account representative for further analysis:

- Monitor protocol log with options 74 (EGTPC) and 75 (App Specific Diameter –Gx/S6b) turned on
- Logs with sessmgr, imsa, and diameter-auth enabled
- Output of **show session disconnect reason** CLI command and the relevant statistics at service level

Show Commands and/or Outputs

show ims-authorization sessions full all

The **Negotiated Supported Features** field in this show command output displays whether or not the P-CSCF Restoration feature is negotiated with PCRF.

This supported feature is displayed only when the feature license is configured.

show aaa group all

The **Supported Features** field in this show command output displays whether or not the P-CSCF Restoration feature is configured as part of the Supported-Features AVP.

This supported feature is displayed only when the feature license is configured.

show license information

If the license to enable the P-CSCF Restoration feature is configured, then the **show license information** command displays the associated license information.

Monitoring Logs

This section provides information on how to monitor the logs that are generated relating to the HSS/PCRF-based P-CSCF Restoration feature.

S6b Diameter Protocol Logs

The **Supported-Features** field is available in AAR/AAA section. The log output generated will appear similar to the following:

```
<<<<OUTBOUND 15:37:23:561 Eventid:92870 (5)
....
[V] [M] Supported-Features:
[M] Vendor-Id: 10415
[V] Feature-List-ID: 1
[V] Feature-List: 1
....
INBOUND>>>> 15:37:23:562 Eventid:92871 (5)
....
[V] [M] Supported-Features:
[M] Vendor-Id: 10415
[V] Feature-List-ID: 1
[V] Feature-List: 1
....
```

The **RAR-Flags** field is available in RAR section. The log output generated will appear similar to the following:

```
INBOUND>>>> 15:37:43:562 Eventid:92871 (5)
....
[M] Re-Auth-Request-Type: AUTHORIZE_ONLY (0)
[V] RAR-Flags: 2
....
```

Gx Diameter Protocol Logs

Under **Supported-Features**, the P-CSCF Restoration **Feature-List** is available in CCR-I/CCA-I section. The output generated will appear similar to the following:

```
<<<<OUTBOUND 13:52:06:117 Eventid:92820(5)
....
[V] [M] Supported-Features:
[M] Vendor-Id: 10415
[V] Feature-List-ID: 1
  [V] Feature-List: 16777217
....
INBOUND>>>>> 13:52:06:118 Eventid:92821(5)
....
[V] [M] Supported-Features:
[M] Vendor-Id: 10415
[V] Feature-List-ID: 1
  [V] Feature-List: 16777216
....
```

The **PCSCF-Restoration-Indication** AVP is available in RAR. The output generated will appear similar to the following:

```
INBOUND>>>>> 13:52:26:119 Eventid:92821(5)
....
[M] Re-Auth-Request-Type: AUTHORIZE_ONLY (0)
[V] PCSCF-Restoration-Indication: 0
....
```

Loop Prevention for Dynamic Rules

Feature Information

Summary Data

Status	New Functionality
Introduced-In Release	21.2
Modified-In Release(s)	Not Applicable
Applicable Product(s)	P-GW
Applicable Platform(s)	ASR 5500
Default Setting	Disabled
Related CDETS ID(s)	CSCvc97345, CSCvd02249
Related Changes in This Release	Not Applicable
Related Documentation	P-GW Administration Guide Command Line Interface Reference

Revision History



Important Revision history details are not provided for features introduced before release 21.2.

Revision Details	Release	Release Date
New in this release.	21.2	April 27, 2017

Feature Description

When a PCC (Dynamic or Predefined) rule installation fails, the PCEF initiates a CCR-U toward the PCRF to report the failed rule. In case the PCRF responds back with same rule definition, then the rule failure CCR-U is initiated again. This results in a loop of rule failure.

With this feature, gateways have the ability to prevent the loop by reporting the rule install failure to PCRF only once until it is successfully installed.

How It Works

This feature is configurable through a CLI command with which, once a failure is being reported for a subscriber, failure for the same rule is suppressed for that subscriber until it is installed successfully. The rulenames are preserved for a subscriber for which the failures are reported. However, when the condition of the rule failure is rectified for an error (for example, rule definition is added to the configuration and the rule is successfully installed), then the gateway removes the rulename from the failed rules list. So, if the failure for that particular rule occurs again, it is reported to the PCRF.

The failed rulename is not checkpointed and so, if a recovery event like session recovery or an ICSR occurs then the failure of these rules are reported once again.

Configuring Loop Prevention for Dynamic Rules

This section explains the configuration procedures required to enable the feature.

Enabling ACS Policy to Control Loop Prevention

Use the following commands under ACS Configuration Mode to enable or disable the feature which prevents the rule failure loop between PCRF and PCEF:

```
configure
  active-charging service<service_name>
    policy-control report-rule-failure-once
  end
```

Notes:

- When configured, CCR-U will be sent only once for the same rule failure.
- By default, the feature is disabled.
- If previously configured, use the **no policy-control report-rule-failure-once** to disable the feature.

Monitoring and Troubleshooting

The following sections describe commands available to monitor the feature.

Show Commands and Outputs

This section provides information regarding show commands and their outputs for the Loop Prevention for Dynamic Rules feature.

show active-charging service all

The output of the above command has been enhanced to display the status (Enabled/Disabled) of the feature. For example:

```
show active-charging service all
.
.
.
Report Rule Failure Once: Enabled
```

show active-charging subscribers full all

The output of the above command has been enhanced to display the new parameter which shows the total number of rule failures not reported. For example:

```
Callid: 4e21 ACSMgr Card/Cpu: 15/0
Active Charging Service name: acs
Active charging service scheme:
ACSMgr Instance: 1 Number of Sub sessions: 1
Data Sessions Active: 0 Dynamic Routes created: 0
Uplink Bytes: 0 Downlink Bytes: 0
Uplink Packets: 0 Downlink Packets: 0
Accel Packets: 0
FastPath Packets: 0
Total NRSPCA Requests: 0 NRSPCA Req. Succeeded: 0
NRSPCA Req. Failed: 0
Total NRUPC Requests: 0 NRUPC Req. Succeeded: 0
NRUPC Req. Failed: 0
Pending NRSPCA Requests: 0 Pending NRUPC Requests: 0
Total Bound Dynamic Rules: 0 Total Bound Predef. Rules: 0
Data Sessions moved: 0
Bearers Terminated for no rules: 0
Failed Rulebase Install (unknown bearer-id): 0
Failed Rule Install (unknown bearer-id): 0
Total number of rule failures not reported: 1
```

show active-charging subsystem all

The output of the above command has been enhanced to display the new parameter which shows the total number of rule failures not reported. For example:

```
Total ACS Managers: 2
Session Creation Succ: 1 Session Creation Fail: 0
.
.
.
Total Number of Unsolicited Downlink packets received : 0
Total Number of ICMP-HU packets sent : 0
```



```

RADIUS Prepaid Statistics:
Total prepaid sess:          0      Current prepaid sess:      0
Total prepaid auth req:     0      Total prepaid auth success: 0
Total prepaid auth fail:    0      Total prepaid errors:      0
Total number of rule failures not reported :      4

Content Filtering URL Cache Statistics:
Total cached entries:       0
Total hits:                 0      Total misses:              0
.
.
.

```

Separation of Accounting Interim Interval Timer for RADIUS and Diameter Rf

Feature Information

Summary Data

Status	New Functionality
Introduced-In Release	21.2
Modified-In Release(s)	Not Applicable
Applicable Product(s)	eHRPD, GGSN, P-GW
Applicable Platform(s)	ASR 5500
Default Setting	Disabled
Related CETS ID(s)	CSCvc97616
Related Changes in This Release	Not Applicable
Related Documentation	AAA Interface Administration and Reference Command Line Interface Reference

Revision History



Important Revision history details are not provided for features introduced before release 21.2.

Revision Details	Release	Release Date
New in this release.	21.2	April 27, 2017

Feature Description

Prior to Release 21.2, the Cisco StarOS platform had a single configuration parameter for sending accounting interim records to RADIUS and Diameter Rf servers. Consequently, it was not possible to send accounting

interim records to RADIUS and Diameter Rf servers with different intervals using the available CLI options. This feature provides a CLI controlled mechanism to have different interim intervals for Diameter Rf and RADIUS accounting applications. Having a separate configurable CLI and interim interval timer values for RADIUS and Diameter Rf servers provides enhanced usability.

How It Works

Currently, the Diameter accounting uses the value configured for RADIUS accounting interim interval. With this feature, configurable through a CLI command, provides an option to separately configure Diameter accounting interim interval for Rf interface. Until Diameter interim CLI is configured with either “no” option or any specific timer value, as a measure for compatibility, RADIUS interim interval value is used for Diameter interim interval. Once Diameter configuration takes effect, any change to RADIUS configuration will not affect Diameter configuration and vice versa. The following table shows the Diameter interim interval values used for different scenarios.

Radius Configuration	Diameter Configuration	Diameter Interim Behavior
No configuration OR Interim Interval: X OR Interim disabled	Interim Interval: Y	Interim Interval: Y Note: X may or may not be same as Y
No configuration OR Interim Interval: X OR Interim disabled	Interim disabled using “No” option	Interim disabled
No configuration OR Interim Interval: X OR Interim disabled	No configuration	Fallback to RADIUS configuration

- Recovery/ICSR behavior: Interim interval configuration used at the time of PDN creation is applicable for entire lifetime of PDN. Recovery/ICSR will not have any impact of existing PDN behavior with regard to Diameter interim interval.
- ICSR Upgrade/Downgrade behavior:
 - Existing session will be recovered based on RADIUS configuration present in old chassis.
 - New session behavior is as per configuration available on newly active chassis.

Limitations

Following are the known limitations of this feature:

1. In case Diameter interim interval CLI is not configured, the P-GW retains the older behavior where Diameter accounting uses the same interim interval value configured for RADIUS accounting.
2. Once diameter accounting configuration is done, it's not possible to go back to the older behavior.

Configuring Diameter Accounting Interim Interval

Use the following commands under AAA Server Group Configuration Mode to configure Diameter accounting interim interval independently from RADIUS accounting interim interval:

```
configure
  context context_name
  aaa group group_name
    diameter accounting interim interval interval_in_seconds
  end
```

Notes:

- *interval_in_seconds*: Specifies the interim interval, and must be in the range of 50 through 40000000.
- If previously configured, use the **no diameter accounting interim interval** to disable the interim accounting messages on Rf interface.
- There is no default Diameter interim interval value.
- In case Diameter interim interval CLI is not configured, the P-GW retains the older behavior where Diameter accounting uses RADIUS interim interval configuration available in AAA server group configuration block.

Monitoring and Troubleshooting

The following sections describe commands available to monitor the feature.

Show Commands and Outputs

This section provides information regarding show commands and their outputs in support of the feature.

```
show aaa group { name <group_name> | all }
```

The output of the above command is modified to display the following new field to show the current configuration for interim interval used for upcoming Diameter Rf accounting sessions:

- Interim-timeout: <50-40000000> or <None>

Following is a sample output where Diameter interim interval is not configured:

```
show aaa group name default
Group name:          default
Context:             pgw

Diameter config:
  Accounting:
```

show configuration [verbose]

```
Request-timeout:      20
Interim-timeout:     None
```

Following is a sample output where Diameter interim interval is configured with the value 900:

```
show aaa group name default
Group name:           default
Context:             pgw

Diameter config:
  Accounting:
    Request-timeout:  20
    Interim-timeout:  900
```

show configuration [verbose]

The output of the above command is modified to display the following new field to show the interval of interim messages in seconds:

- diameter accounting interim interval <value_in_seconds>

Following is a sample output where Diameter interim interval is configured with the value 60:

```
show configuration context isp verbose
config
  context isp
    aaa group default
      diameter accounting interim interval 60
```

Enhancement to OCS Failure Reporting for Gy

Feature Information

Summary Data

Status	Modified Functionality
Introduced-In Release	21.1
Modified-In Release(s)	21.2
Applicable Product(s)	P-GW, SAEGW
Applicable Platform(s)	ASR 5500
Default Setting	Enabled
Related CDETS ID(s)	CSCvc93904
Related Changes in This Release	Not Applicable
Related Documentation	AAA Interface Administration and Reference P-GW Administration Guide SAEGW Administration Guide

Revision History



Important Revision history details are not provided for features introduced before release 21.2.

Revision Details	Release	Release Date
New in this release.	21.2	April 27, 2017

Feature Description

When Cisco-Event-Trigger-Type AVP is installed by PCRF in CCA-I, CCA-U or in RAR messages with value CREDIT_CONTROL_FAILURE (5), then the Cisco-Event grouped AVP is sent by the P-GW to PCRF in CCR-U message with the exact value of OCS failure code. This trigger is sent only when Gy failure occurs and based on the configuration (Credit-Control-Failure-Handling), the 'Continue' action is taken and Gy session moves to Offline state.

With this enhancement, the exact failure code is reported to the PCRF instead of the range. For example, when the Cisco-Event-Trigger-Type is CREDIT_CONTROL_FAILURE (5) and OCS failure code is 3002 in CCA-U, then in CCR-U towards PCRF Cisco-CC-Failure-Type (as part of grouped AVP Cisco-Event) is sent with a value of 3002.

Support Added for RAN/NAS Cause Code for S5/S8 and S2b Interfaces

Feature Information

Summary Data

Status	Modified Functionality
Introduced-In Release	21.1
Modified-In Release(s)	21.2
Applicable Product(s)	P-GW, S-GW, SAEGW
Applicable Platform(s)	ASR 5500
Default Setting	Disabled
Related CETS ID(s)	CSCuy93748/CSCvc97356
Related Changes in This Release	Not Applicable
Related Documentation	<i>P-GW Administration Guide</i> <i>S-GW Administration Guide</i> <i>SAEGW Administration Guide</i> <i>Command Line Interface Reference</i>

Revision History



Important Revision history details are not provided for features introduced before Release 21.2.

Revision Details	Release	Release Date
New in this release.	21.2	April 27, 2017

Feature Changes



Important This is a license controlled feature. There are separate licenses for this feature. You must enable the existing license of NPLI or contact your Cisco account representative for information on how to obtain the custom license.

For billing co-ordination at IMS domain and VoWiFi deployments, an operator may require access to the RAN or NAS (or both) release cause code information available at P-CSCF. The P-GW provides detailed RAN/NAS cause information with ANI information received from the access network to the P-GW and further down to the PCRF based on the following events:

- Bearer deactivation (Delete Bearer Response/Delete Bearer Command)
- Session deactivation (Delete Session Request)
- Bearer creation/modification failures (Create/Update Bearer Response with cause as FAILURE)

The IMS network can retrieve detailed RAN and/or NAS release cause codes information from the access network that is used for call performance analysis, user QoE analysis, and proper billing reconciliation. This feature is supported on the S5, S8, Gx, and S2b interfaces.

This feature includes support RAN/NAS cause IE in Create Bearer Response, Update Bearer Response, Delete Bearer Response, Delete Bearer Command, and Delete Session Request. The following table shows the supported protocol type for RAN/NAS cause IE.

Table 61: Protocol Type for RAN/NAS IE

Interface	Supported Protocol Type for RAN/NAS IE
S5/S8	S1AP Cause (1)/EMM Cause (2)/ESM Cause (3)
S2b	Diameter Cause (4)/IKEv2 Cause (5)



Note Any protocol type value that is received apart from the supported protocol type values listed in the table are ignored and not forwarded to the PCRF.

GTP interface Requirements for RAN/NAS Cause

For S5/S8 interface, RAN/NAS cause is supported for the following messages for the dpca-custom8 dictionary.

- Failed Create Bearer Response
- Failed Update Bearer Response
- Delete Session Request
- Delete Bearer Response
- Delete Bearer Command

For S2b interface, RAN/NAS cause is supported for the following messages for the custom dpca-custom8 dictionary:

- Failed Create Bearer Response
- Failed Update Bearer Response
- Delete Session Request

Gx interface Requirements for RAN/NAS Cause

The RAN/NAS cause is added for the custom dpca-custom8 dictionary to ensure that the RAN/NAS cause is populated. The Gx interface behavior to handle RAN/NAS cause is as follows:

Table 62: Gx Interface Requirements for RAN/NAS Cause

Message	GTP Cause	Gx Message Carrying RAN-NAS Cause Information
Create Bearer Response	Accepted	RAN/NAS cause is not expected as per 29.274 Table 7.2.4-2. Therefore, if it is received, it is ignored and not forwarded to the PCRF.
	Temporarily rejected due to HO in progress.	RAN/NAS cause with this GTP cause is not applicable as per 29.274 Table C.4. Therefore, if it is received, it is ignored and not forwarded to the PCRF.
	Other GTP Causes	CCR-U

Message	GTP Cause	Gx Message Carrying RAN-NAS Cause Information
Update Bearer Response	Accepted	RAN/NAS cause is not expected as per 29.274 Table 7.2.16-2. Therefore, if it is received, it is ignored and not forwarded to the PCRF.
	No Resources Available	CCR-U Note If UE-initiated (MBC) bearer modification fails with GTP cause “NO RESOURCES AVAILABLE”, P-GW deletes the entire PDN session. In this case, RAN-NAS cause information is forwarded as part of CCR-T message.
	Context Not Found	CCR-U Note If the Update Bearer Response is received with the message level cause as "CONTEXT NOT FOUND", which leads to the PDN deletion, then the RAN-NAS cause information is forwarded as part of the CCR-T message.
	Temporarily rejected due to HO in progress.	RAN/NAS cause with this GTP cause is not applicable as per 29.274 Table C.4. Therefore, if it is received, it is ignored and not forwarded to the PCRF.
	Other GTP Causes	CCR-U

Message	GTP Cause	Gx Message Carrying RAN-NAS Cause Information
Delete Bearer Response	Temporarily rejected due to HO in progress	<p>RAN/NAS cause with this GTP cause is not applicable as per 29.274 Table C.4. Therefore, if it is received, it is ignored and not forwarded to the PCRF.</p> <p>Note</p> <ul style="list-style-type: none"> • If RAN/NAS cause is received in the Delete Bearer Response, which is triggered as a part of the Delete Bearer command and cause as “Request Accepted”, P-GW forwards the RAN/NAS cause (received in Delete Bearer Response) to the PCRF. • If RAN/NAS cause is received in the Delete Bearer command and Delete Bearer Response with HO in progress, the RAN/NAS Cause received in the Delete Bearer command is forwarded to the PCRF. • If RAN/NAS Cause is received in the Delete Bearer command and Delete Bearer Response with Accepted/Other Cause and new RAN/NAS Cause, the new RAN/NAS cause is forwarded to the PCRF.
	Accepted / Other GTP CCR-UCauses	<p>CCR-U</p> <p>Note If RAN/NAS cause is received in the delete bearer response that is initiated through RAR/CCA-U, then P-GW does not send CCR-U to the PCRF to report the RAN/NAS cause.</p> <p>This support is introduced in 29.212 release 13.5 with "Enhance RAN/NAS" feature".</p>
Delete Session Request	Accepted	CCR-T

ANI Behavior Towards PCRF

Section 4.5.6, 4.5.7, 4.5.12 of 3GPP 29.212 v13.4.0 mentions that if the RAN-NAS-Cause feature is supported, the PCEF should provide the available access network information within the 3GPP-User-Location-Info AVP (if available), TWAN-Identifier (if available and Trusted-WLAN feature is supported), User-Location-Info-Time AVP (if available), and 3GPP-MS-TimeZone AVP (if available).

The USER-LOCATION-INFO-TIME AVP is added to the dpca-custom8 dictionary, which is sent to the PCRF (if available) as a part of ANI. Also, new PROTOCOL-TYPE, 1 to 5 are supported for RAN/NAS. This AVP can be seen in the CCR-U and CCR-T (whenever applicable). Also the new PROTOCOL-TYPE (S1AP Cause, EMM Cause, ESM Cause, IKEv2, DIAMETER) is visible on the Gx interface (if the same is received over the S5/S8/S2b interface).

ANI Behavior for S5/S8 Interface

Along with RAN/NAS cause, P-GW also sends following information to the PCRF, if available, for the dpca-custom8 dictionary:

Table 63: Mapping of GTP IE to ANI AVPs on Gx Interface

GTP IE	Gx AVP
UE Time Zone	3GPP-MS-TimeZone
ULI Timestamp	User-Location-Info-Time
User Location Information	3GPP-User-Location-Info

ANI information is sent to the PCRF irrespective of the event triggers configured when the RAN/NAS feature is enabled.

ANI Behavior for S2b Interface

ANI information is not sent towards PCRF for the dpca-custom8 dictionary. Also, the TWAN-Identifier is not supported as part of ANI for the dpca-custom8 dictionary.

Limitations

Following are the limitations of this feature:

- Support of RAN/NAS cause information is added only for the dpca-custom8 dictionary.
- PGW processes first two RAN/NAS cause IE (max one RAN and max one NAS) information received from the GTP interface. For example, if the access network misbehaves and sends RAN/NAS cause list with two NAS and one RAN then only first two causes are considered and validated. In this case, there are two NAS causes, only first NAS cause is populated at the Gx interface.
- RAN/NAS information is populated only on the Gx interface, no other interface is impacted.

Command Changes

diameter encode-supported-features netloc-ran-nas-cause

Use the existing CLI command, **diameter encode-supported-features netloc-ran-nas-cause** to enable the RAN/NAS cause on each of the S5/S8 and S2b interfaces.

This feature is disabled by default.

To enable this feature, enter the following commands:

```

configure
context ISP1
ims-auth-service MSGx
policy-control
diameter encode-supported-features netloc-ran-nas-cause
end

```



CHAPTER 24

Gx Support for eMPS

- [Feature Summary and Revision History, on page 619](#)
- [Feature Description, on page 620](#)
- [How It Works, on page 621](#)
- [Configuring Gx Support for eMPS, on page 622](#)
- [Monitoring and Troubleshooting the Gx Support for eMPS, on page 624](#)

Feature Summary and Revision History

Summary Data

Applicable Product(s) or Functional Area	<ul style="list-style-type: none"> • P-GW • SAEGW
Applicable Platform(s)	ASR 5500
Feature Default	<ul style="list-style-type: none"> • For GTP and Gx Prioritization for eMPS sessions: Disabled - Configuration Required • For Parsing of DRMP AVP: Enabled - Always-on
Related Changes in This Release	Not Applicable
Related Documentation	<ul style="list-style-type: none"> • <i>Command Line Interface Reference</i> • <i>P-GW Administration Guide</i> • <i>SAEGW Administration Guide</i>

Revision History

Revision Details	Release
First introduced.	21.3

Feature Description

The National Security/Emergency Preparedness (NS/EP) Next Generation Network (NGN) Priority Services (NGN-PS) (formerly called NGN Government Emergency Telecommunications Service (GETS)) is a set of voice, video and data services that are based on services available from public packet-switched Service Providers, and that provide priority treatment in support of National Security and Emergency Preparedness (NS/EP) communications. A Service Provider is a public telecommunications service provider authorized by the NCS to provide GETS (including Legacy GETS), Wireless Priority Service (WPS), and/or NS/EP NGN Priority Services (NS/EP NGN-PS). The NS/EP NGN-PS provides priority treatment for a Service User's NS/EP communications and is required when the Service Providers' networks are impaired due to congestion and/or damaged from natural disasters (such as floods, earthquakes, and hurricanes) and man-made disasters (such as physical, cyber, or other forms of terrorist attacks).

With this feature, support is added for NS/EP NGN priority service over the network which eventually requires the P-GW node to first identify an eMPS bearer/session (based on configured Enhanced Multimedia Priority Service (eMPS) evolved Allocation and Retention Priority (eARP)), and then prioritize their GTP and Gx signaling over the network.



Important For supplemental information related to eMPS profile configuration (configuring the eMPS ARPs, which are used to identify a bearer/session as an eMPS bearer/session), and eMPS statistics, refer to the *Expanded Prioritization for VoLTE/Emergency Calls* chapter in the *P-GW Administration Guide* or the *SAEGW Administration Guide*.

Prioritization of GTP and Gx Signaling

1. Prioritizing the GTP signaling for eMPS sessions implies:
 - Excluding the eMPS session's GTP control traffic from throttling due to Load Overload Control (For supplemental information about Load Overload Control, refer to the *3GPP R12 GTP-C Load and Overload Control Support on the P-GW, SAEGW, and S-GW* chapter in the *P-GW Administration Guide* or the *SAEGW Administration Guide*).
2. Prioritizing the Gx signaling for eMPS sessions implies:
 - Excluding the eMPS session's Gx traffic from outgoing RLF throttling (RLF throttling is only applicable for Gx outgoing messages).
 - Excluding the eMPS session's Gx traffic from max-outstanding queue decisions.

Parsing the DRMP AVP from RAR Messages

Support is also extended for parsing the DRMP AVP from RAR messages on the Gx interface. And, if the DRMP value is received as 0, the corresponding response (RAA) message is prioritized, that is to say, excluded from Gx RLF throttling and max-outstanding queue decisions.

Relationships to Other Features

This feature is related to eMPS profile, Load Overload Control, Gx RLF throttling, and Max-outstanding configuration features, and one or more among these features may require additional license key to be installed.

How It Works

The following is a high-level overview of how this feature works:

- The newly introduced CLI command, **diameter session-prioritization**, is used to enable or disable Gx signaling prioritization for eMPS sessions. This CLI command is at policy-control configuration in IMS-authorization service, and it is required to:
 - Exclude the eMPS session's Gx traffic from RLF throttling.
 - Exclude the eMPS session's Gx traffic from max-outstanding queue decisions.

The following Gx signaling is excluded from RLF throttling and max-outstanding queue decisions:

- All Gx signaling for an eMPS session.
 - Gx signaling related to eMPS upgrade/downgrade toggling which also includes inter-access technology handovers.
 - Gx signaling which is initiated as part of eMPS upgrade failure (UBRsp/CBRsp failures from access side).
- Support is added for parsing DRMP AVP from RAR and prioritizing corresponding RAA if the DRMP value is received as 0. This behavior is enabled by default and applicable to both eMPS and non-eMPS sessions, and independent of the diameter session-prioritization CLI command.
 - **GTP Load Overload Throttling behavior:** The Cisco P-GW supports GTP Load Overload Throttling for both self-overload and peer-overload scenarios. However, GTP signaling for eMPS sessions should be excluded from throttling even under these conditions. For this prioritization to work, all the eARP values configured under eMPS profile must be configured under Load Overload profile configuration (for both self-overload and peer-overload). For additional eARP values configured under Load Overload profile configuration (self-overload and peer-overload), the legacy behavior of self-overload and peer-overload continues.

If there is any change in the eARP values configured under eMPS profile configuration:

1. For existing sessions:
 - a. The new configuration is considered for eMPS upgrade/downgrade toggling, when there is any change in eARP value of existing bearer(s) of that session or at the time of bearer creation for that session.
 - b. Till the session is marked eMPS, the legacy behavior of self-overload and peer-overload continues for the newly configured eARP values.
2. For new sessions:
 - a. New configuration takes effect seamlessly.

- Session recovery and ICSR recover the eMPS state of the session.
- As per Government Industry Requirements (GIR) document, eMPS marking is done only for P-GW EUTRAN and S4-SGSN PDNs.

Limitations

Following are the known limitations of the feature:

- When a session is marked eMPS, it will continue to be excluded from GTP throttling under GTP self-overload situation even after it has been downgraded to a non-eMPS session.
- If for a session, any Update Bearer Request or Create Bearer Request which can upgrade the session from non-eMPS to eMPS fails due to internal failure, the corresponding CCR-U may not be prioritized sometimes.

Configuring Gx Support for eMPS

This section provides information about the CLI commands available in support of the feature.

Configuring eMPS Profile

Use the following commands to configure eMPS profile, which is used to identify/mark a bearer/session as an eMPS bearer/session.

```
configure
  emps-profile emps_profile
  earp earp_value earp_value
end
```



Important For supplemental information related to eMPS profile configuration (configuring the eMPS ARPs, which are used to identify a bearer/session as an eMPS bearer/session), and eMPS statistics, refer to the *Expanded Prioritization for VoLTE/Emergency Calls* chapter in the *P-GW Administration Guide* or the *SAEGW Administration Guide*.

Enabling Gx Prioritization for eMPS Sessions

Use the following commands under the Policy Control Configuration Mode to enable prioritization of Gx messages based on eMPS state of the session.

```
configure
  context context_name
  ims-auth-service service_name
  policy-control
    [ no ] diameter session-prioritization
  end
```

Notes:

- By default, the **diameter session-prioritization** CLI command is disabled and Gx messages will not be prioritized based on eMPS value.
- If previously configured, use the **no diameter session-prioritization** CLI command to set the default behavior.
- The **diameter session-prioritization** CLI takes affect when Gx, along with eMPS profile, is enabled in the configuration.

Enabling GTP Prioritization for eMPS Sessions under GTP Load Overload Throttling

Use the following configurations for prioritizing the eMPS sessions related to GTP signaling, in case the GTP Peer Overload Control and/or Self-Protection configuration is enabled in the system. These configurations provide option to exclude eMPS session's GTP traffic from throttling under Peer Overload/Self Protection conditions.

configure

```
emp-profile emp_profile_name
  earp earp_value earp_value
end
```

configure

```
gtpc-overload-control-profile overload_profile
  throttling-behavior earp earp_value earp_value exclude
  self-protection-behavior earp earp_value earp_value exclude
end
```

Notes:

- **emp-profile** *emp_profile_name*: Configures eMPS profile for defining attributes of an eMPS session. The *emp_profile_name* is a string of size from 1 to 63.
- **earp**: Configures a maximum of 3 eARP priority level (PL) values so that sessions with configured eARP priority values can be marked as eMPS sessions. Maximum of 3 eARP values can be configured under an eMPS profile.
- As per above configuration, sessions with any one bearer with either eARP value will be excluded from Load Overload GTP Throttling.



Important

For supplemental information related to GTP-C overload control throttling/self-protection behavior and configurations details, refer to the *3GPP R12 GTP-C Load and Overload Control Support on the P-GW, SAEGW, and S-GW* chapter in the *P-GW Administration Guide* or the *SAEGW Administration Guide*.

For supplemental information related to eMPS profile configuration (configuring the eMPS ARPs, which are used to identify a bearer/session as an eMPS bearer/session), and eMPS statistics, refer to the *Expanded Prioritization for VoLTE/Emergency Calls* chapter in the *P-GW Administration Guide* or the *SAEGW Administration Guide*.

For information related to configuration of Gx RLF Throttling and Gx max-outstanding queue, refer the *CLI Configuration Guide*.

Verifying the Gx Support for eMPS Configuration

This section provides information to verify the Gx Support for eMPS configuration.

show configuration

The output of this CLI command has been enhanced to display the following new field:

- diameter session-prioritization

show configuration verbose

The output of this CLI command has been enhanced to display the following new field:

- diameter session-prioritization

Monitoring and Troubleshooting the Gx Support for eMPS

This section provides information about CLI commands available to monitor and troubleshoot the feature.

show ims-authorization policy-control statistics

Use this CLI command to view statistics related to the number of prioritized DRMP messages. Following is a partial sample output:

```
show ims-authorization policy-control statistics
```

Rule Installation Failure:

Resource Limitation:	0	Unknown Bearer ID:	0
Invalid QCI:	0	Invalid ARP:	0
Bearer-Id in QoS:	0	Parse Error:	0
Invalid Redirect Address:	0	ADC Absent:	0
Incorrect Metering Method:	0	Incorrect Rating Group:	0
Incorrect Online AVP:	0	Incorrect Offline AVP:	0
Incorrect Flow Status:	0	Incorrect Usage Monitoring AVP:	0
Incorrect Required Access Info:	0	Incorrect Flow Description:	0
Incorrect Reporting Level:	0		

DRMP Statistics:

RAR with P0 priority:	0	RAR with other priority:	2
-----------------------	---	--------------------------	---



CHAPTER 25

Gy Interface Support

This chapter provides an overview of the Gy interface and describes how to configure the Gy interface.

Gy interface support is available on the Cisco system for the following products:

- GGSN
- HA
- IPSG
- PDSN
- P-GW

It is recommended that before using the procedures in this chapter you select the configuration example that best meets your service model, and configure the required elements for that model as described in the administration guide for the product that you are deploying.

- [Feature Summary and Revision History, on page 625](#)
- [Introduction, on page 626](#)
- [Features and Terminology, on page 628](#)
- [Configuring Gy Interface Support, on page 668](#)

Feature Summary and Revision History

Summary Data

Applicable Product(s) or Functional Area	PGW
Applicable Platform(s)	<ul style="list-style-type: none">• ASR 5500• VPC-DI• VPC-SI
Related Changes in This Release	Not Applicable

Related Documentation	<ul style="list-style-type: none"> • <i>Command Line Interface Reference</i> • <i>PGW Administration Guide</i> • <i>Statistics and Counters Reference</i>
-----------------------	--

Revision History



Important Revision history details are not provided for features introduced before releases 21.2 and N5.1.

Revision Details	Release
Support is added for addition of server unreachable field in CDR.	21.27
First introduced.	21.22

Introduction

The Gy interface is the online charging interface between the PCEF/GW (Charging Trigger Function (CTF)) and the Online Charging System (Charging-Data-Function (CDF)).

The Gy interface makes use of the Active Charging Service (ACS) / Enhanced Charging Service (ECS) for real-time content-based charging of data services. It is based on the 3GPP standards and relies on quota allocation. The Online Charging System (OCS) is the Diameter Credit Control server, which provides the online charging data to the PCEF/GW. With Gy, customer traffic can be gated and billed in an online or prepaid style. Both time- and volume-based charging models are supported. In these models differentiated rates can be applied to different services based on ECS shallow- or deep-packet inspection.

In the simplest possible installation, the system will exchange Gy Diameter messages over Diameter TCP links between itself and one prepay server. For a more robust installation, multiple servers would be used. These servers may optionally share or mirror a single quota database so as to support Gy session failover from one server to the other. For a more scalable installation, a layer of proxies or other Diameter agents can be introduced to provide features such as multi-path message routing or message and session redirection features.

The following figure shows the Gy reference point in the policy and charging architecture.

Figure 102: PCC Logical Architecture

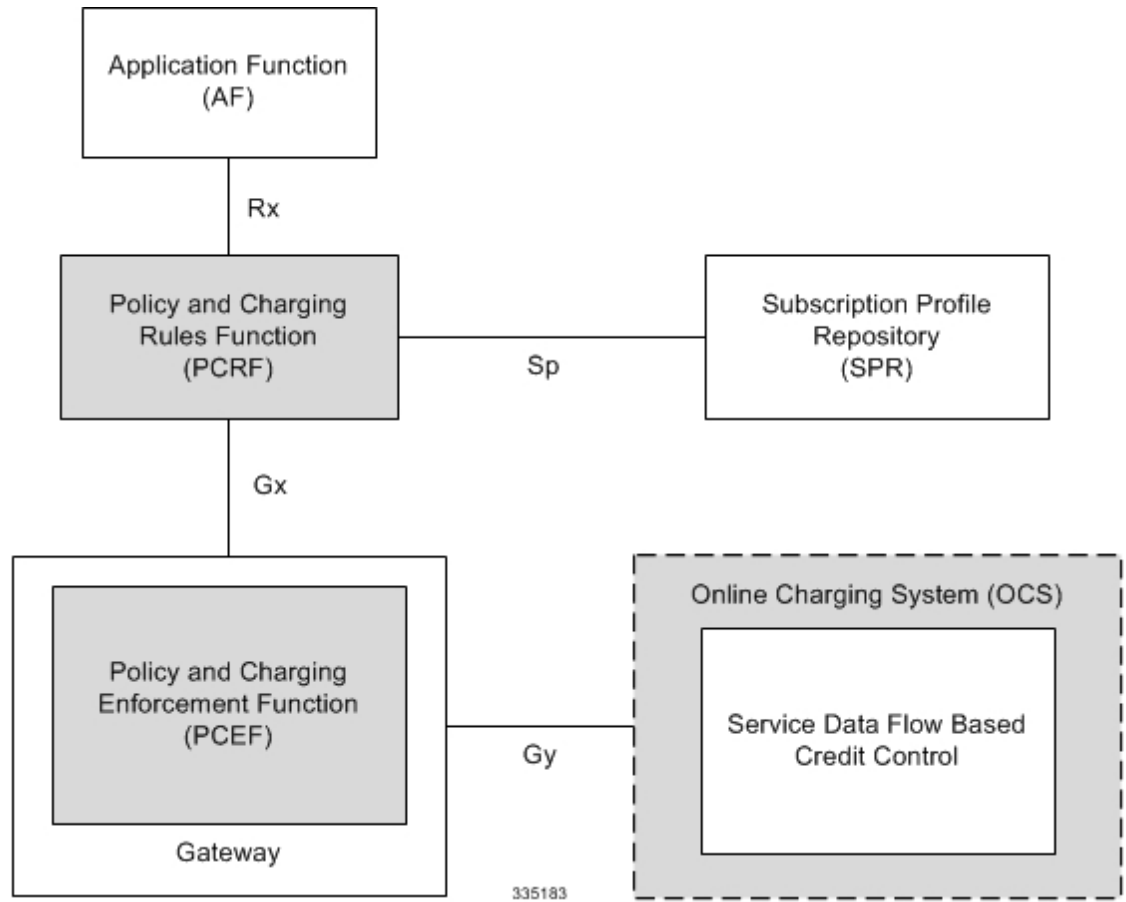

The following figure shows the Gy interface between CTF/Gateway/PCEF/Client running ECS and OCS (CDF/Server). Within the PCEF/GW, the Gy protocol functionality is handled in the DCCA module (at the ECS).

Figure 103: Gy Architecture

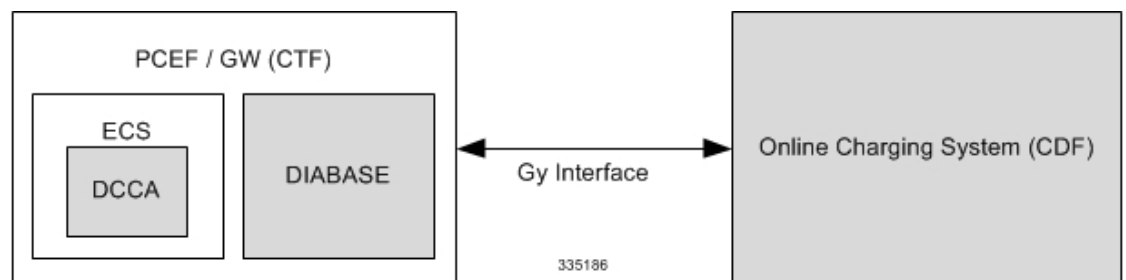

License Requirements

The Gy interface support is a licensed Cisco feature. A separate feature license may be required. Contact your Cisco account representative for detailed information on specific licensing requirements. For information on

installing and verifying licenses, refer to the *Managing License Keys* section of the *Software Management Operations* chapter in the *System Administration Guide*.

Supported Standards

Gy interface support is based on the following standards:

- IETF RFC 4006: Diameter Credit Control Application; August 2005
- 3GPP TS 32.299 V9.6.0 (2010-12) 3rd Generation Partnership Project; Technical Specification Group Services and System Aspects; Telecommunication management; Charging management; Diameter charging applications (Release 9)

Features and Terminology

This section describes features and terminology pertaining to Gy functionality.

Charging Scenarios



Important

Online charging for events ("Immediate Event Charging" and "Event Charging with Reservation") is not supported. Only "Session Charging with Reservation" is supported.

Session Charging with Reservation

Session Charging with Unit Reservation is used for credit control of sessions.

Decentralized Unit Determination and Centralized Rating

In this scenario, the CTF requests the reservation of units prior to session supervision. An account debit operation is carried out following the conclusion of session termination.

Centralized Unit Determination and Centralized Rating

In this scenario, the CTF requests the OCS to reserve units based on the session identifiers specified by the CTF. An account debit operation is carried out following the conclusion of session.

Decentralized Unit Determination and Decentralized Rating



Important

Decentralized Rating is not supported in this release. Decentralized Unit determination is done using CLI configuration.

In this scenario, the CTF requests the OCS to assure the reservation of an amount of the specified number of monetary units from the subscriber's account. An account debit operation that triggers the deduction of the amount from the subscriber's account is carried out following the conclusion of session establishment.

Basic Operations



Important Immediate Event Charging is not supported in this release. "Reserve Units Request" and "Reserve Units Response" are done for Session Charging and not for Event Charging.

Online credit control uses the basic logical operations "Debit Units" and "Reserve Units".

- Debit Units Request; sent from CTF to OCS: After receiving a service request from the subscriber, the CTF sends a Debit Units Request to the OCS. The CTF may either specify a service identifier (centralised unit determination) or the number of units requested (decentralised unit determination). For refund purpose, the CTF sends a Debit Units Request to the OCS as well.
- Debit Units Response; sent from OCS to CTF: The OCS replies with a Debit Units Response, which informs the CTF of the number of units granted as a result of the Debit Units Request. This includes the case where the number of units granted indicates the permission to render the requested service. For refund purpose, the OCS replies with a Debit Units Response.
- Reserve Units Request; sent from CTF to OCS: Request to reserve a number of units for the service to be provided by an CTF. In case of centralised unit determination, the CTF specifies a service identifier in the Reserve Unit Request, and the OCS determines the number of units requested. In case of decentralised unit determination, the number of units requested is specified by the CTF.
- Reserve Units Response; sent from OCS to CTF: Response from the OCS which informs the CTF of the number of units that were reserved as a result of the "Reserve Units Request".

Session Charging with Unit Reservation (SCUR) use both the "Debit Units" and "Reserve Units" operations. SCUR uses the Session Based Credit Control procedure specified in RFC 4006. In session charging with unit reservation, when the "Debit Units" and "Reserve Units" operations are both needed, they are combined in one message.



Important Cost-Information, Remaining-Balance, and Low-Balance-Indication AVPs are not supported.

The consumed units are deducted from the subscriber's account after service delivery. Thus, the reserved and consumed units are not necessarily the same. Using this operation, it is also possible for the CTF to modify the current reservation, including the return of previously reserved units.

Re-authorization

The server may specify an idle timeout associated with a granted quota. Alternatively, the client may have a configurable default value. The expiry of that timer triggers a re-authorization request.

Mid-session service events (re-authorization triggers) may affect the rating of the current service usage. The server may instruct the credit control client to re-authorize the quota upon a number of different session related triggers that can affect the rating conditions.

When a re-authorization is trigger, the client reports quota usage. The reason for the quota being reported is notified to the server.

Threshold based Re-authorization Triggers

The server may optionally include an indication to the client of the remaining quota threshold that triggers a quota re-authorization.

Termination Action

The server may specify to the client the behavior on consumption of the final granted units; this is known as termination action.

Diameter Base Protocol

The Diameter Base Protocol maintains the underlying connection between the Diameter Client and the Diameter Server. The connection between the client and server is TCP based. There are a series of message exchanges to check the status of the connection and the capabilities.

- Capabilities Exchange Messages: Capabilities Exchange Messages are exchanged between the diameter peers to know the capabilities of each other and identity of each other.
 - Capabilities Exchange Request (CER): This message is sent from the client to the server to know the capabilities of the server.
 - Capabilities Exchange Answer (CEA): This message is sent from the server to the client in response to the CER message.



Important

Acct-Application-Id is not parsed and if sent will be ignored by the PCEF/GW. In case the Result-Code is not DIAMETER_SUCCESS, the connection to the peer is closed.

- Device Watchdog Request (DWR): After the CER/CEA messages are exchanged, if there is no more traffic between peers for a while, to monitor the health of the connection, DWR message is sent from the client. The Device Watchdog timer (Tw) is configurable in PCEF/GW and can vary from 6 through 30 seconds. A very low value will result in duplication of messages. The default value is 30 seconds. On two consecutive expiries of Tw without a DWA, the peer is taken to be down.



Important

DWR is sent only after Tw expiry after the last message that came from the server. Say if there is continuous exchange of messages between the peers, DWR might not be sent if (Current Time - Last message received time from server) is less than Tw.

- Device Watchdog Answer (DWA): This is the response to the DWR message from the server. This is used to monitor the connection state.
- Disconnect Peer Request (DPR): This message is sent to the peer to inform to shutdown the connection. PCEF/GW only receives this message. There is no capability currently to send the message to the diameter server.

- **Disconnect Peer Answer (DPA):** This message is the response to the DPR request from the peer. On receiving the DPR, the peer sends DPA and puts the connection state to "DO NOT WANT TO TALK TO YOU" state and there is no way to get the connection back except for reconfiguring the peer again.

A timeout value for retrying the disconnected peer must be provided.

- **Tw Timer Expiry Behavior:** The connection between the client and the server is taken care by the DIABASE application. When two consecutive Tw timers are expired, the peer state is set to idle and the connection is retried to be established. All the active sessions on the connection are then transferred to the secondary connection if one is configured. All new session activations are also tried on the secondary connection.

There is a connection timeout interval, which is also equivalent to Tw timer, wherein after a CER has been sent to the server, if there is no response received while trying to reestablish connection, the connection is closed and the state set to idle.

Diameter Credit Control Application

The Diameter Credit Control Application (DCCA) is a part of the ECS subsystem. For every prepaid customer with Diameter Credit Control enabled, whenever a session comes up, the Diameter server is contacted and quota for the subscriber is fetched.

Quota Behavior

Various forms of quotas are present that can be used to charge the subscriber in an efficient way. Various quota mechanisms provide the end user with a variety of options to choose from and better handling of quotas for the service provider.

Time Quotas

The Credit-Control server can send the CC-Time quota for the subscriber during any of the interrogation of client with it. There are also various mechanisms as discussed below which can be used in conjunction with time quota to derive variety of methods for customer satisfaction.

- **Quota Consumption Time:** The server can optionally indicate to the client that the quota consumption must be stopped after a period equal to the "Quota Consumption Time" in which no packets are received or at session termination, whichever is sooner. The idle period equal to the Quota Consumption Time is included in the reported usage. The quota is consumed normally during gaps in traffic of duration less than or equal to the Quota-Consumption-Time. Quota consumption resumes on receipt of a further packet belonging to the service data flow.

If packets are allowed to flow during a CCR (Update)/CCA exchange, and the Quota-Consumption-Time AVP value in the provided quota is the same as in the previously provided quota, then the Quota-Consumption-Time runs normally through this procedure. For example, if 5 seconds of a 10 second QCT timer have passed when a CCR(U) is triggered, and the CCA(U) returns 2 seconds later, then the QCT timer will expire 3 seconds after the receipt of the CCA and the remaining unaccounted 5 seconds of usage will be recorded against the new quota even though no packets were transmitted with the new quota.

A locally configurable default value in the client can be used if the server does not send the QCT in the CCA.

- **Combinational Quota:** Discrete-Time-Period (DTP) and Continuous-Time-Period (CTP) defines mechanisms that extends and generalize the Quota-Consumption-Time for consuming time-quota.

- Both DTP and CTP uses a "base-time-interval" that is used to create time-envelopes of quota used.
- Instead of consuming the quota linearly, DTP and CTP consumes the granted quota discretely in chunks of base-time-interval at the start of the each base-time-interval.
- Selection of one of this algorithm is based on the "Time-Quota-Mechanism" AVP sent by the server in CCA.
- Reporting usage can also be controlled by Envelope-Reporting AVP sent by the server in CCA during the quota grant. Based on the value of this AVP, the usage can be reported either as the usage per envelope or as usual cumulative usage for that grant.
- Discrete-Time-Period: The base-time-interval defines the length of the Discrete-Time-Period. So each time-envelope corresponds to exactly one Discrete-Time-Period. So when a traffic is detected, an envelope of size equal to Base-Time-Interval is created. The traffic is allowed to pass through the time-envelope. Once the traffic exceeds the base-time-interval another new envelope equal to the base-time-interval is created. This continues till the quota used exceeds the quota grant or reaches the threshold limit for that quota.
- Continuous-Time-Period: Continuous time period mechanism constructs time envelope out of consecutive base-time intervals in which the traffic occurred up to and including a base time interval which contains no traffic. Therefore the quota consumption continues within the time envelope, if there was traffic in the previous base time interval. After an envelope has closed, then the quota consumption resumes only on the first traffic following the closure of the envelope. The envelope for CTP includes the last base time interval which contains no traffic.

The size of the envelope is not constant as it was in Parking meter. The end of the envelope can only be determined retrospectively.

- Quota Hold Time: The server can specify an idle timeout associated with a granted quota using the Quota-Holding-Time AVP. If no traffic associated with the quota is observed for this time, the client understands that the traffic has stopped and the quota is returned to the server. The client starts the quota holding timer when quota consumption ceases. This is always when traffic ceases, i.e. the timer is re-started at the end of each packet. It applies equally to the granted time quota and to the granted volume quota. The timer is stopped on sending a CCR and re-initialized on receiving a CCA with the previous used value or a new value of Quota-Holding-Time if received.

Alternatively, if this AVP is not present, a locally configurable default value in the client is used. A Quota-Holding-Time value of zero indicates that this mechanism is not used.

- Quota Validity Time: The server can optionally send the validity time for the quota during the interrogation with the client. The Validity-Time AVP is present at the MSCC level and applies equally to the entire quota that is present in that category. The quota gets invalidated at the end of the validity time and a CCR-Update is sent to the server with the Used-Service-Units AVP and the reporting reason as VALIDITY_TIME. The entire quota present in that category will be invalidated upon Quota-Validity-Time expiry and traffic in that category will be passed or dropped depending on the configuration, till a CCA-Update is received with quota for that category.

Validity-Time of zero is invalid. Validity-Time is relative and not absolute.

For the Final-Reporting, the AVP "SN-Remaining-Service-Unit" will be encoded.

The "SN-Remaining-Service-Unit" AVP behavior is inherited from "Used-Service-Unit" AVP. This Final-Reporting is missing for the Remaining-Service-Unit AVP, which is now incorporated.

Volume Quota

The server sends the CC-Total-Octets AVP to provide volume quota to the subscriber. DCCA currently supports only CC-Total-Octets AVP, which applies equally to uplink and downlink packets. If the total of uplink and downlink packets exceeds the CC-Total-Octets granted, the quota is assumed to be exhausted.

If CC-Input-Octets and/or CC-Output-Octets is provided, the quota is counted against CC-Input-Octets and/or CC-Output-Octets respectively.



Important Restricting usages based on CC-Input-Octets and CC-Output-Octets is not supported in this release.

Units Quota

The server can also send a CC-Service-Specific-Units quota which is used to have packets counted as units. The number of units per packet is a configurable option.

Granting Quota

Gy implementation assumes that whenever the CC-Total-Octets AVP is present, volume quota has been granted for both uplink and downlink.

If the Granted-Service-Unit contains no data, Gy treats it as an invalid CCA.

If the values are zero, it is assumed that no quota was granted.

If the AVP contains the sub AVPs without any data, it is assumed to be infinite quota.

Additional parameters relating to a category like QHT, QCT is set for the category after receiving a valid volume or time grant.

If a default quota is configured for the subscriber, and subscriber traffic is received it is counted against the default quota. The default quota is applicable only to the initial request and is not regranted during the course of the session. If subscriber disconnects and reconnects, the default quota will be applied again for the initial request.

Requesting Quota

Quotas for a particular category type can be requested using the Requested-Service-Unit AVP in the CCR. The MSCC is filled with the Rating-Group AVP which corresponds to the category of the traffic and Requested-Service-Unit (RSU) AVP without any data.

The Requested-Service-Unit can contain the CC AVPs used for requesting specific quantity of time or volume grant. Gy CLI can be used to request quota for a category type.

Alternatively quota can also be requested from the server preemptively for a particular category in CCR- I. When the server grants preemptive quota through the Credit control answer response, the quota will be used only when traffic is hit for that category. Quota can be preemptively requested from the Credit Control server from the CLI.

The MSCC AVP is skipped in the CCR-I on server retries. Corresponding quota usage will be reported in the next CCR-U (MSCC AVP with USU and RSU).

Reporting Quota

Quotas are reported to the server for number of reasons including:

- Threshold

- QHT Expiry
- Quota Exhaustion
- Rating Condition Change
- Forced Reauthorization
- Validity Time Expiry
- Final during Termination of Category Instance from Server

For the above cases except for QHT and Final, the Requested-Service-Unit AVP is present in the CCR.

Reporting Reason is present in CCR to let the server know the reason for the reporting of Quota. The Reporting-Reason AVP can be present either in MSCC level or at Used Service Unit (USU) level depending on whether the reason applies to all quotas or to single quota.

When one of these conditions is met, a CCR Update is sent to the server containing a Multiple-Services-Credit-Control AVP(s) indicating the reason for reporting usage in the Reporting-Reason and the appropriate value(s) for Trigger, where appropriate. Where a threshold was reached, the DCCA still has the amount of quota available to it defined by the threshold.

For all other reporting reasons the client discards any remaining quota and either discards future user traffic matching this category or allows user traffic to pass, or buffers traffic according to configuration.

For Reporting-Reason of Rating Condition Change, Gy requires the Trigger Type AVP to be present as part of the CCR to indicate which trigger event caused the reporting and re-authorization request.

For Reporting-Reason of end user service denied, this happens when a category is blacklisted by the credit control server, in this case a CCR-U is sent with used service unit even if the values as zero. When more quota is received from the server for that particular category, the blacklisting is removed.

If a default quota has been set for the subscriber then the usage from the default quota is deducted from the initial GSU received for the subscriber for the Rating Group or Rating Group and Service ID combination.

Default Quota Handling

- If default quota is set to 0, no data is passed/reported.
- If default quota is configured and default quota is not exhausted before OCS responds with quota, traffic is passed. Initial default quota used is counted against initial quota allocated. If quota allocated is less than the actual usage then actual usage is reported and additional quota is requested. If no additional quota is available then traffic is denied.
- If default quota is not exhausted before OCS responds with denial of quota, gateway blocks traffic after OCS response. Gateway will report usage on default quota even in this case in CCR-U (FINAL) or CCR-T.
- If default quota is consumed before OCS responds, if OCS is not declared dead (see definition in use case 1 above) then traffic is blocked until OCS responds.

Thresholds

The Gy client supports the following threshold types:

- Volume-Quota-Threshold
- Time-Quota-Threshold
- Units-Quota-Threshold

A threshold is always associated with a particular quota and a particular quota type. In the Multiple-Services-Credit-Control AVP, the Time-Quota-Threshold, Volume-Quota-Threshold, and Unit-Quota-Threshold are optional AVPs.

They are expressed as unsigned numbers and the units are seconds for time quota, octets for volume quota and units for service specific quota. Once the quota has reached its threshold, a request for more quotas is triggered toward the server. User traffic is still allowed to flow. There is no disruption of traffic as the user still has valid quota.

The Gy sends a CCR-U with a Multiple-Services-Credit-Control AVP containing usage reported in one or more User-Service-Unit AVPs, the Reporting-Reason set to THRESHOLD and the Requested-Service-Unit AVP without data.

When quota of more than one type has been assigned to a category, each with its own threshold, then the threshold is considered to be reached once one of the unit types has reached its threshold even if the other unit type has not been consumed.

When reporting volume quota, the DCCA always reports uplink and downlink separately using the CC-Input-Octets AVP and the CC-Output-Octets AVP, respectively.

On receipt of more quotas in the CCA the Gy discards any quota not yet consumed since sending the CCR. Thus the amount of quota now available for consumption is the new amount received less any quota that may have been consumed since last sending the CCR.

Conditions for Reauthorization of Quota

Quota is re-authorized/requested from the server in case of the following scenarios:

- Threshold is hit
- Quota is exhausted
- Validity time expiry
- Rating condition change:
 - Cellid change: Applicable only to GGSN and P-GW implementations.
 - LAC change: Applicable only to GGSN and P-GW implementations.
 - QoS change
 - RAT change
 - SGSN/Serving-Node change: Applicable only to GGSN and P-GW implementations.

Discarding or Allowing or Buffering Traffic to Flow

Whenever Gy is waiting for CCA from the server, there is a possibility of traffic for that particular traffic type to be encountered in the Gy. The behavior of what needs to be done to the packet is determined by the configuration. Based on the configuration, the traffic is either allowed to pass or discarded or buffered while waiting for CCA from the server.

This behavior applies to all interrogation of client with server in the following cases:

- No quota present for that particular category
- Validity timer expiry for that category

- Quota exhausted for that category
- Forced Reauthorization from the server

In addition to allowing or discarding user traffic, there is an option available in case of quota exhausted or no quota circumstances to buffer the traffic. This typically happens when the server has been requested for more quota, but a valid quota response has not been received from the server, in this case the user traffic is buffered and on reception of valid quota response from the server the buffered traffic is allowed to pass through.

Procedures for Consumption of Time Quota

- QCT is zero: When QCT is deactivated, the consumption is on a wall-clock basis. The consumption is continuous even if there is no packet flow.
- QCT is active: When QCT is present in the CCA or locally configured for the session, then the consumption of quota is started only at the time of first packet arrival. The quota is consumed normally till last packet arrival plus QCT time and is passed till the next packet arrival.

If the QCT value is changed during intermediate interrogations, then the new QCT comes into effect from the time the CCA is received. For instance, if the QCT is deactivated in the CCA, then quota consumptions resume normally even without any packet flow. Or if the QCT is activated from deactivation, then the quota consumption resume only after receiving the first packet after CCA.

- QHT is zero: When QHT is deactivated, the user holds the quota indefinitely in case there is no further usage (for volume quota and with QCT for time quota). QHT is active between the CCA and the next CCR.
- QHT is non-zero: When QHT is present in CCA or locally configured for the session, then after a idle time of QHT, the quota is returned to the server by sending a CCR-Update and reporting usage of the quota. On receipt of CCR-U, the server does not grant quota. QHT timer is stopped on sending the CCR and is restarted only if QHT is present in the CCA.

QHT timer is reset every time a packet arrives.

Envelope Reporting

The server may determine the need for additional detailed reports identifying start time and end times of specific activity in addition to the standard quota management. The server controls this by sending a CCA with Envelope-Reporting AVP with the appropriate values. The DCCA client, on receiving the command, will monitor for traffic for a period of time controlled by the Quota-Consumption-Time AVP and report each period as a single envelope for each Quota-Consumption-Time expiry where there was traffic. The server may request envelope reports for just time or time and volume. Reporting the quota back to the server, is controlled by Envelope AVP with Envelope-Start-Time and Envelope-End-Time along with usage information.

Credit Control Request

Credit Control Request (CCR) is the message that is sent from the client to the server to request quota and authorization. CCR is sent before the establishment of MIP session, and at the termination of the MIP session. It can be sent during service delivery to request more quotas.

- Credit Control Request - Initial (CCR-I)
- Credit Control Request - Update (CCR-U)
- Credit Control Request - Terminate (CCR-T)

- Credit Control Answer (CCA)
- Credit Control Answer - Initial (CCA-I)
- Credit Control Answer - Update (CCA-U)

If the MSCC AVP is missing in CCA-U it is treated as invalid CCA and the session is terminated.

- Credit Control Answer - Terminate (CCA-T)

If call is cleared when there is a pending update, the gateway will wait for CCA-U to arrive or timeout to happen (whichever happens first).

When the calls were terminated due to audit failure during ICSR switchover, DCCA allows generation of CCR-Ts over Gy interface.

The following figure depicts the call flow for a simple call request in the GGSN/P-GW/IPSG Gy implementation.

Figure 104: Gy Call Flow for Simple Call Request for GGSN/P-GW/IPSG

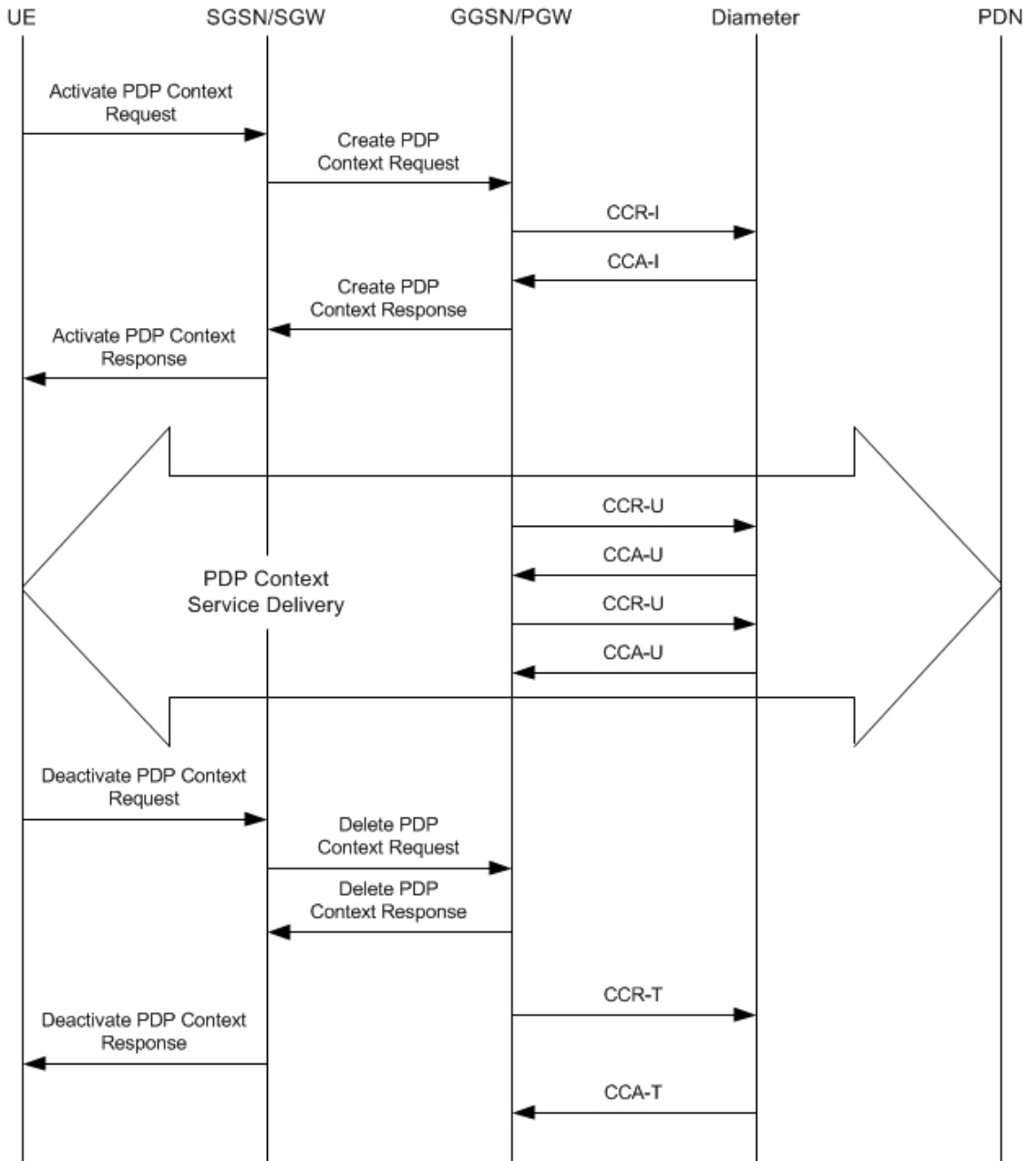

335187

The following figure depicts the call flow for a simple call request in the HA Gy implementation.

Figure 105: Gy Call Flow for Simple Call Request for HA

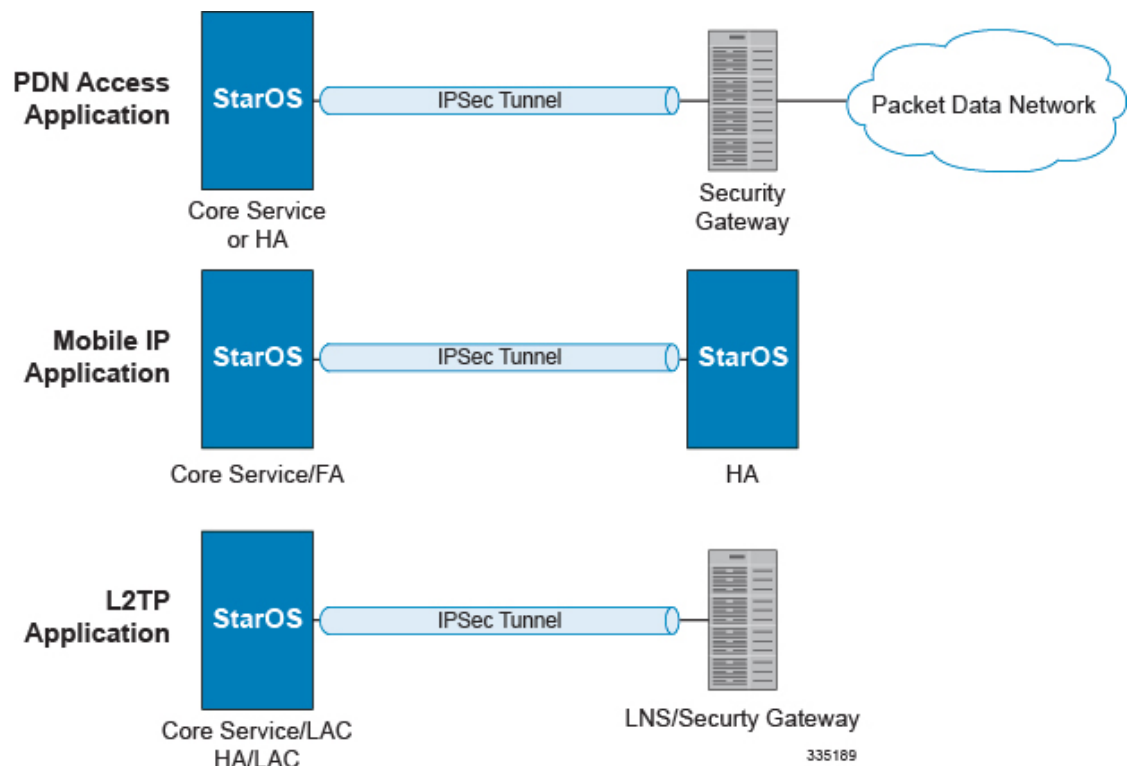

Tx Timer Expiry Behavior

A timer is started each time a CCR is sent out from the system, and the response has to arrive within Tx time. The timeout value is configurable in the Diameter Credit Control Configuration mode.

In case there is no response from the Diameter server for a particular CCR, within Tx time period, and if there is an alternate server configured, the CCR is sent to the alternate server after Tw expiry as described in "Tw Timer expiry behavior" section.

It also depends on the Credit-Control-Session-Failover AVP value for the earlier requests. If this AVP is present and is coded to FAILOVER_SUPPORTED then the credit-control message stream is moved to the secondary server, in case it is configured. If the AVP value is FAILOVER_NOT_SUPPORTED, then the call is dropped in case of failures, even if a secondary server is configured.

Once CCR-U is sent out over Gy interface, the containers are cached only after CCA-U is received successfully. The Rf trigger is sent only after receiving CCA-U message.

Redirection

In the Final-Unit-Indication AVP, if the Final-Unit-Action is REDIRECT or Redirect-Server AVP is present at command level, redirection is performed.

The redirection takes place at the end of consumption of quota of the specified category. The Gy sends a CCR-Update without any RSU or Rating-Group AVP so that the server does not give any more quotas.

If the Final-Unit-Action AVP is RESTRICT_ACCESS, then according to the settings in Restriction-Filter-Rule AVP or Filter-Id AVP. Gy sends CCR-Update to the server with used quota.

Triggers

The Diameter server can provide with the triggers for which the client should reauthorize a particular category. The triggers can be configured locally as well but whatever trigger is present in the CCA from the server will have precedence.



Important In this release, Gy triggers are not supported for HA.

The trigger types that are supported are:

- SGSN/Serving-Node Change
- QoS Change - Any
- RAT Change
- LAC Change
- CellID Change

On any event as described in the Trigger type happens, the client reauthorizes quota with the server. The reporting reason is set as `RATING_CONDITION_CHANGE`.

Tariff Time Change

The tariff change mechanism applies to each category instance active at the time of the tariff change whenever the server indicated it should apply for this category.

The concept of dual coupon is supported. Here the server grants two quotas, which is accompanied by a Tariff-Time-Change, in this case the first granted service unit is used until the tariff change time, once the tariff change time is reached the usage is reported up to the point and any additional usage is not accumulated, and then the second granted service unit is used.

If the server expects a tariff change to occur within the validity time of the quota it is granting, then it includes the Tariff-Time-Change AVP in the CCA. The DCCA report usage, which straddles the change time by sending two instances of the Used-Service-Unit AVP, one with Tariff-Change-Usage set to `UNIT_BEFORE_TARIFF_CHANGE`, and one with Tariff-Change-Usage set to `UNIT_AFTER_TARIFF_CHANGE`, and this independently of the type of units used by application. Both Volume and Time quota are reported in this way.

The Tariff time change functionality can as well be done using Validity-Time AVP, where in the Validity-Time is set to Tariff Time change and the client will reauthorize and get quota at Validity-Time expiry. This will trigger a lot of reauthorize request to the server at a particular time and hence is not advised.

Tariff-Time-Usage AVP along with the Tariff-Time-Change AVP in the answer message to the client indicates that the quotas defined in Multiple-Services-Credit-Control are to be used before or after the Tariff Time change. Two separate quotas are allocated one for before Tariff-Time-Change and one for after Tariff-Time-Change. This gives the flexibility to the operators to allocate different quotas to the users for different periods of time. In this case, the DCCA should not send the Before-Usage and After-Usage counts in the update messages to the server. When Tariff-Time-Change AVP is present without Tariff-Time-Usage AVP in the answer message, then the quota is used as in single quota mechanism and the client has to send before usage and after usage quotas in the updates to the server.



Important In this release, Gy does not support UNIT_INDETERMINATE value.

In the StarOS 21.20.22 release, support for Tariff-Time-Change AVP is enhanced to maintain continuous traffic flow in the fast path and the user's traffic rate when the Tariff-Time-Change AVP is received from Gy for a Rating Group.

Final Unit Indication

The Final-Unit-Indication AVP can be present in the CCA from the server to indicate that the given quota is the final quota from the server and the corresponding action as specified in the AVP needs to be taken.

Final Unit Indication at Command Level

Gy currently does not support FUI AVP at command level. If this AVP is present at command level it is ignored. If the FUI AVP is present at command level and the Final-Unit-Action AVP set to TERMINATE, Gy sends a CCR-Terminate at the expiry of the quota, with all quotas in the USU AVP.



Important FUI AVP at command level is only supported for Terminate action.

Final Unit Indication at MSCC Level

If the Final-Unit-Indication AVP is present at MSCC level, and if the Final-Unit-Action AVP is set to TERMINATE, a CCR-Update is sent at the expiry of the allotted quota and report the usage of the category that is terminated.

For information on redirection cases refer to the [Redirection, on page 639](#).

Credit Control Failure Handling

CCFH AVP defines what needs to be done in case of failure of any type between the client and the server. The CCFH functionality can be defined in configuration but if the CCFH AVP is present in the CCA, it takes precedence. CCFH AVP gives flexibility to have different failure handling.

Gy supports the following Failure Handling options:

- TERMINATE
- CONTINUE
- RETRY AND TERMINATE

CCFH with Failover Supported

In case there is a secondary server is configured and if the CC-Session-Failover AVP is set to FAILOVER_SUPPORTED, the following behavior takes place:

- Terminate: On any Tx expiry for the CCR-I the message is discarded and the session is torn down. In case of CCR-Updates and Terminates the message is sent to the secondary server after response timeout and the session is proceeded with the secondary server. In case there is a failure with the secondary server too, the session is torn down.
- Continue: On any Tx expiry, the message is sent to the secondary server after response timeout and the session is proceeded with the secondary server. In case there is a failure with the secondary server too, the session is still established, but without quota management.

- **Retry and Terminate:** On any Tx expiry, the message is sent to the secondary server after the response timeout. In case there is a failure with secondary server too, the session is taken down.

CCFH with Failover Not Supported

In case there is a secondary server configured and if the CC-Session-Failover AVP is set to `FAILOVER_NOT_SUPPORTED`, the following behavior takes place as listed below. Same is the case if there is no secondary server configured on the system.

- **Terminate:** On any Tx expiry, the session is taken down.
- **Continue:** On any Tx expiry, the session is still established, but without quota management.
- **Retry and Terminate:** On any Tx expiry, the session is taken down.

Failover Support

The CC-Session-Failover AVP and the Credit-Control-Failure-Handling (CCFH) AVP may be returned by the CC server in the CCA-I, and are used by the DCCA to manage the failover procedure. If they are present in the CCA they override the default values that are locally configured in the system.

If the CC-Session-Failover is set to `FAILOVER_NOT_SUPPORTED`, a CC session will never be moved to an alternative Diameter Server.

If the value of CC-Session-Failover is set to `FAILOVER_SUPPORTED`, then the Gy attempts to move the CC session to the alternative server when it considers a request to have failed, i.e:

- On receipt of result code "DIAMETER_UNABLE_TO_DELIVER", "DIAMETER_TOO_BUSY", or "DIAMETER_LOOP_DETECTED".
- On expiry of the request timeout.
- On expiry of Tw without receipt of DWA, if the server is connected directly to the client.

The CCFH determines the behavior of the client in fault situations. If the Tx timer expires then based on the CCFH value the following actions are taken:

- **CONTINUE:** Allow the MIP session and user traffic for the relevant category or categories to continue, regardless of the interruption (delayed answer). Note that quota management of other categories is not affected.
- **TERMINATE:** Terminate the MIP session, which affects all categories.
- **RETRY_AND_TERMINATE:** Allow the MIP session and user traffic for the relevant category or categories to continue, regardless of the interruption (delayed answer). The client retries to send the CCR when it determines a failure-to-send condition and if this also fails, the MIP session is then terminated.

After the failover action has been attempted, and if there is still a failure to send or temporary error, depending on the CCFH action, the following action is taken:

- **CONTINUE:** Allow the MIP session to continue.
- **TERMINATE:** Terminate the MIP session.
- **RETRY_AND_TERMINATE:** Terminate the MIP session.

Recovery Mechanisms

DCCA supports a recovery mechanism that is used to recover sessions without much loss of data in case of Session Manager failures. There is a constant check pointing of Gy data at regular intervals and at important events like update, etc.



Important The DCCA supports maximum of three bearers (including default) for the ICSR Checkpointing and Recovery. When more than three bearers are configured in the DCCA, checkpointing occurs from Active to Standby for all the bearers. However, during recovery, only the first three bearers are recovered and the rest remain in the memory consuming resources.

For more information on recovery mechanisms, please refer to the *System Administration Guide*.

Error Mechanisms

Following are supported Error Mechanisms.

Unsupported AVPs

All unsupported AVPs from the server with "M" bit set are ignored.

Invalid Answer from Server

If there is an invalid answer from the server, Gy action is dependent on the CCFH setting:

- In case of continue, the MIP session context is continued without further control from Gy.
- In case of terminate and retry-and-terminate, the MIP session is terminated and a CCR-T is sent to the diameter server.

Result Code Behavior

- **DIAMETER_RATING_FAILED**: On reception of this code, Gy discards all traffic for that category and does not request any more quota from the server. This is supported at the MSCC level and not at the command level.
- **DIAMETER_END_USER_SERVICE_DENIED**: On reception of this code, Gy temporarily blacklists the category and further traffic results in requesting new quota from the server. This is supported at the MSCC level and not at the command level.
- **DIAMETER_CREDIT_LIMIT_REACHED**: On reception of this code, Gy discards all traffic for that category and waits for a configured time, after which if there is traffic for the same category requests quota from the server. This is supported at the MSCC level and not at the command level.
- **DIAMETER_CREDIT_CONTROL_NOT_APPLICABLE**: On reception of this code, Gy allows the session to establish, but without quota management. This is supported only at the command level and not at the MSCC level.
- **DIAMETER_USER_UNKNOWN**: On reception of this code, DCCA does not allow the credit control session to get established, the session is terminated. This result code is supported only at the command level and not at the MSCC level.

For all other permanent/transient failures, Gy action is dependent on the CCFH setting.

Supported AVPs

The Gy functionality supports the following AVPs:

- Supported Diameter Credit Control AVPs specified in RFC 4006:
 - CC-Input-Octets (AVP Code: 412):
Gy supports this AVP only in USU.
 - CC-Output-Octets (AVP Code: 414):
Gy supports this AVP only in USU.
 - CC-Request-Number (AVP Code: 415)
 - CC-Request-Type (AVP Code: 416):
Gy currently does not support EVENT_REQUEST value.
 - CC-Service-Specific-Units (AVP Code: 417)
 - CC-Session-Failover (AVP Code: 418)
 - CC-Time (AVP Code: 420):
Gy does not support this AVP in RSU.
 - CC-Total-Octets (AVP Code: 421):
Gy does not support this AVP in RSU.
 - Credit-Control-Failure-Handling (AVP Code: 427)
 - Final-Unit-Action (AVP Code: 449):
Supported at Multiple-Services-Credit-Control grouped AVP level and not at command level.
 - Final-Unit-Indication (AVP Code: 430):
Fully supported at Multiple-Services-Credit-Control grouped AVP level and partially supported (TERMINATE) at command level.
 - Granted-Service-Unit (AVP Code: 431)
 - Multiple-Services-Credit-Control (AVP Code: 456)
 - Multiple-Services-Indicator (AVP Code: 455)
 - Rating-Group (AVP Code: 432)
 - Redirect-Address-Type (AVP Code: 433):
Gy currently supports only URL (2) value.
 - Redirect-Server (AVP Code: 434)
 - Redirect-Server-Address (AVP Code: 435)
 - Requested-Service-Unit (AVP Code: 437)
 - Result-Code (AVP Code: 268)
 - Service-Context-Id (AVP Code: 461)

- Service-Identifier (AVP Code: 439)
- Subscription-Id (AVP Code: 443)
- Subscription-Id-Data (AVP Code: 444)
- Subscription-Id-Type (AVP Code: 450)
- Tariff-Change-Usage (AVP Code: 452):
Gy does NOT support UNIT_INDETERMINATE (2) value.
- Tariff-Time-Change (AVP Code: 451)
- Used-Service-Unit (AVP Code: 446):
Gy sends only incremental counts for all the AVPs from the last CCA-U.
- User-Equipment-Info (AVP Code: 458)
- User-Equipment-Info-Type (AVP Code: 459):
Gy currently supports only IMEISV value.
Cisco GGSN and P-GW support IMEISV by default.
- User-Equipment-Info-Value (AVP Code: 460)
- Validity-Time (AVP Code: 448)
- Supported 3GPP specific AVPs specified in 3GPP TS 32.299:
 - 3GPP-Charging-Characteristics (AVP Code: 13)
 - 3GPP-Charging-Id (AVP Code: 2)
 - 3GPP-GGSN-MCC-MNC (AVP Code: 9)
 - 3GPP-GPRS-QoS-Negotiated-Profile (AVP Code: 5)
 - 3GPP-IMSI-MCC-MNC (AVP Code: 8)
 - 3GPP-NSAPI (AVP Code: 10)
 - 3GPP-PDP-Type (AVP Code: 3)
 - 3GPP-RAT-Type (AVP Code: 21)
 - 3GPP-Selection-Mode (AVP Code: 12)
 - 3GPP-Session-Stop-Indicator (AVP Code: 11)
 - 3GPP-SGSN-MCC-MNC (AVP Code: 18)
 - 3GPP-User-Location-Info (AVP Code: 22)
 - Base-Time-Interval (AVP Code: 1265)
 - Charging-Rule-Base-Name (AVP Code: 1004)
 - Envelope (AVP Code: 1266)
 - Envelope-End-Time (AVP Code: 1267)

- Envelope-Reporting (AVP Code: 1268)
 - Envelope-Start-Time (AVP Code: 1269)
 - GGSN-Address (AVP Code: 847)
 - Offline-Charging (AVP Code: 1278)
 - PDP-Address (AVP Code: 1227)
 - PDP-Context-Type (AVP Code: 1247)
This AVP is present only in CCR-I.
 - PS-Information (AVP Code: 874)
 - Quota-Consumption-Time (AVP Code: 881):
This optional AVP is present only in CCA.
 - Quota-Holding-Time (AVP Code: 871):
This optional AVP is present only in the CCA command. It is contained in the Multiple-Services-Credit-Control AVP. It applies equally to the granted time quota and to the granted volume quota.
 - Reporting-Reason (AVP Code: 872):
Gy currently does not support the POOL_EXHAUSTED (8) value. It is used in case of credit-pooling which is currently not supported.
 - Service-Information (AVP Code: 873):
Only PS-Information is supported.
 - SGSN-Address (AVP Code: 1228)
 - Time-Quota-Mechanism (AVP Code: 1270):
The Gy server may include this AVP in an Multiple-Services-Credit-Control AVP when granting time quota.
 - Time-Quota-Threshold (AVP Code: 868)
 - Time-Quota-Type (AVP Code: 1271)
 - Trigger (AVP Code: 1264)
 - Trigger-Type (AVP Code: 870)
 - Unit-Quota-Threshold (AVP Code: 1226)
 - Volume-Quota-Threshold (AVP Code: 869)
- Supported Diameter AVPs specified in 3GPP TS 32.299 V8.1.0:
 - Auth-Application-Id (AVP Code: 258)
 - Destination-Host (AVP Code: 293)
 - Destination-Realm (AVP Code: 283)
 - Disconnect-Cause (AVP Code: 273)

- Error-Message (AVP Code: 281)
- Event-Timestamp (AVP Code: 55)
- Failed-AVP (AVP Code: 279)
- Multiple-Services-Credit-Control (AVP Code: 456)
- Origin-Host (AVP Code: 264)
- Origin-Realm (AVP Code: 296)
- Origin-State-Id (AVP Code: 278)
- Redirect-Host (AVP Code: 292)
- Redirect-Host-Usage (AVP Code: 261)
- Redirect-Max-Cache-Time (AVP Code: 262)
- Rating-Group (AVP Code: 432)
- Result-Code (AVP Code: 268)
- Route-Record (AVP Code: 282)
- Session-Id (AVP Code: 263)
- Service-Context-Id (AVP Code: 461)
- Service-Identifier (AVP Code: 439)
- Supported-Vendor-Id (AVP Code: 265)
- Termination-Cause (AVP Code: 295)
- Used-Service-Unit (AVP Code: 446)
- User-Name (AVP Code: 1)

Unsupported AVPs

This section lists the AVPs that are NOT supported.

- NOT Supported Credit Control AVPs specified in RFC 4006:
 - CC-Correlation-Id
 - CC-Money
 - CC-Sub-Session-Id
 - CC-Unit-Type (AVP Code: 454)
 - Check-Balance-Result
 - Cost-Information (AVP Code: 423)
 - Cost-Unit (AVP Code: 445)
 - Credit-Control

- Currency-Code (AVP Code: 425)
- Direct-Debiting-Failure-Handling (AVP Code: 428)
- Exponent (AVP Code: 429)
- G-S-U-Pool-Identifier (AVP Code: 453)
- G-S-U-Pool-Reference (AVP Code: 457)
- Requested-Action (AVP Code: 436)
- Service-Parameter-Info (AVP Code: 440)
- Service-Parameter-Type (AVP Code: 441)
- Service-Parameter-Value (AVP Code: 442)
- Unit-Value (AVP Code: 424)
- Value-Digits (AVP Code: 447)

- NOT supported Diameter AVPs specified in 3GPP TS 32.299 V8.1.0:
 - Acct-Application-Id (AVP Code: 259)
 - Error-Reporting-Host (AVP Code: 294)
 - Experimental-Result (AVP Code: 297)
 - Experimental-Result-Code (AVP Code: 298)
 - Proxy-Host
 - Proxy-Info
 - Proxy-State

- NOT supported 3GPP-specific AVPs specified in 3GPP TS 32.299 V8.1.0:
 - 3GPP-CAMEL-Charging-Info (AVP Code: 24)
 - 3GPP-MS-TimeZone (AVP Code: 23)
 - 3GPP-PDSN-MCC-MNC
 - Authorised-QoS
 - Access-Network-Information
 - Adaptations
 - Additional-Content-Information
 - Additional-Type-Information
 - Address-Data
 - Address-Domain
 - Addressee-Type
 - Address-Type
 - AF-Correlation-Information
 - Alternate-Charged-Party-Address
 - Application-provided-Called-Party-Address
 - Application-Server

- Application-Server-Information
- Applic-ID
- Associated-URI
- Aux-Applic-Info
- Bearer-Service
- Called-Asserted-Identity
- Called-Party-Address
- Calling-Party-Address
- Cause-Code
- Charged-Party
- Class-Identifier
- Content-Class
- Content-Disposition
- Content-Length
- Content-Size
- Content-Type
- Data-Coding-Scheme
- Deferred-Location-Event-Type
- Delivery-Report-Requested
- Destination-Interface
- Domain-Name
- DRM-Content
- Early-Media-Description
- Event
- Event-Type
- Expires
- File-Repair-Supported
- IM-Information
- IMS-Charging-Identifier (ICID)
- IMS-Communication-Service-Identifier
- IMS-Information
- Incoming-Trunk-Group-ID
- Interface-Id
- Interface-Port
- Interface-Text
- Interface-Type
- Inter-Operator-Identifier
- LCS-APN
- LCS-Client-Dialed-By-MS
- LCS-Client-External-ID
- LCS-Client-ID
- LCS-Client-Name
- LCS-Client-Type
- LCS-Data-Coding-Scheme
- LCS-Format-Indicator
- LCS-Information

- LCS-Name-String
- LCS-Requestor-ID
- LCS-Requestor-ID-String
- Location-Estimate
- Location-Estimate-Type
- Location-Type
- Low-Balance-Indication
- MBMS-Information
- MBMS-User-Service-Type
- Media-Initiator-Flag
- Media-Initiator-Party
- Message-Body
- Message-Class
- Message-ID
- Message-Size
- Message-Type
- MMBox-Storage-Requested
- MM-Content-Type
- MMS-Information
- Node-Functionality
- Number-Of-Participants
- Number-Of-Received-Talk-Bursts
- Number-Of-Talk-Bursts
- Originating-IOI
- Originator
- Originator-Address
- Originator-Interface
- Originator-SCCP-Address
- Outgoing-Trunk-Group-ID
- Participant-Access-Priority
- Participants-Group
- Participants-Involved
- PDG-Address
- PDG-Charging-Id
- PoC-Change-Condition
- PoC-Change-Time
- PoC-Controlling-Address
- PoC-Group-Name
- PoC-Information
- PoC-Server-Role
- PoC-Session-Id
- PoC-Session-Initiation-Type
- PoC-Session-Type
- PoC-User-Role
- PoC-User-Role-IDs
- PoC-User-Role-info-Units

- Positioning-Data
- Priority
- PS-Append-Free-Format-Data (AVP Code: 867):
The PCEF/GW ignores this AVP if no PS free format data is stored for the online charging session.
- PS-Free-Format-Data (AVP Code: 866)
- PS-Furnish-Charging-Information (AVP Code: 865)
- RAI (AVP Code: 909)
- Read-Reply-Report-Requested
- Received-Talk-Burst-Time
- Received-Talk-Burst-Volume
- Recipient-Address
- Recipient-SCCP-Address
- Refund-Information
- Remaining-Balance
- Reply-Applic-ID
- Reply-Path-Requested
- Requested-Party-Address
- Role-of-node
- SDP-Answer-Timestamp
- SDP-Media-Component
- SDP-Media-Description
- SDP-Media-Name
- SDP-Offer-Timestamp
- SDP-Session-Description
- SDP-TimeStamp
- Served-Party-IP-Address
- Service-Generic-Information
- Service-ID
- Service-Specific-Data
- Service-Specific-Info
- Service-Specific-Type
- SIP-Method
- SIP-Request-Timestamp
- SIP-Response-Timestamp
- SM-Discharge-Time
- SM-Message-Type
- SM-Protocol-Id
- SMSC-Address
- SMS-Information
- SMS-Node
- SM-Status
- SM-User-Data-Header
- Submission-Time
- Talk-Burst-Exchange

- Talk-Burst-Time
- Talk-Burst-Volume
- Terminating-IOI
- Time-Stamps
- Token-Text
- Trunk-Group-ID
- Type-Number
- User-Participating-Type
- User-Session-ID
- WAG-Address
- WAG-PLMN-Id
- WLAN-Information
- WLAN-Radio-Container
- WLAN-Session-Id
- WLAN-Technology
- WLAN-UE-Local-IPAddress

PLMN and Time Zone Reporting

For some implementations of online charging, the OCS requires the PCEF to reporting location-specific subscriber information. For certain subscriber types, subscriber information such as PLMN, Time Zone, and ULI can be sent over the Gy interface as the subscriber changes location, time zone, and serving networks to provide accurate online charging services. Such information can be reported independently from time and volume-based reporting.

PLMN and Time Zone Reporting feature is enabled to support location event reporting based on triggers from Gx, when the following conditions are met:

- Session-based Gy is not initiated due to the absence of charging-actions in rulebase with Credit-Control enabled or due to delayed Gy session initiation.
- PLMN and Time Zone Reporting feature is either enabled in the credit control group or through the use of triggers received from Gx.

If session-based Gy initiation fails or the session goes offline due to configuration or network issues, event-based Gy session will not be initiated.



Important Note that the failure-handling will not be supported for event-based Gy.

Though, in event-based Gy, multiple events can be reported independently and simultaneously this is presently not supported. If an event occurs when the CCA-Event (CCA-E) of the previously reported event is awaited, then the new event is queued and reported only when a CCA-E is received or the message is timed out.

To enable the PLMN and Time Zone Reporting feature, the PCRF shall send the Trigger AVP (Trigger Type 1, Trigger Type 2) at the command level in a CCA.

The Event-based Gy session will be terminated in the following scenarios:

- On termination of the bearer/subscriber (subscriber level Gy).
- Initiation of session-based Gy session (delayed session initiation).

- Once the CCR-E transaction is complete and there are no further events to report.

For information on how to configure this feature, refer to the *Gy Interface Support* chapter in the administration guide for the product that uses the Gy interface functionality.

Interworking between Session-based Gy and Event-based Gy

If both session-based Gy and event-based Gy mode are activated, then session-based Gy will take precedence i.e. all the events will be reported through CCR-U if the corresponding triggers are enabled. Event-based Gy mode will be active only when session-based Gy has been disabled and has never been activated previously for this session during its lifetime.

OCS Unreachable Failure Handling Feature

The OCS Unreachable Failure Handling feature is required to handle when OCS goes down or unavailable. This feature is otherwise noted as Assume Positive for Gy.

The OCS is considered unavailable/unreachable in the following scenarios:

- PCEF transmits a CCR-U or CCR-I message but no response is received before the specified timeout
- Diameter Watchdog request times out to the current RDR, causing the TCP connection state to be marked down
- Diameter command-level error codes received in a CCA
- If the PCEF is unable to successfully verify transmission of a CCR-T, the PCEF will not assign interim quota, because the user has disconnected.

The error result codes can be configured using the CLI command **servers-unreachable behavior-triggers initial-request { result-code { any-error | result-code [to end-result-code] }** } to trigger the server unreachable mode. The same is applicable for the update request also. For more information on the CLI command, see the *Credit Control Configuration Mode Commands* chapter of the *Command Line Interface Reference*. However, if the CLI command **no servers-unreachable behavior-triggers { initial-request | update-request } result-code { any-error | result-code [to end-result-code] }** is configured, then the default set of hard-coded error codes are applicable.

The default set is:

- UNABLE_TO_DELIVER 3002
- UNABLE_TOO_BUSY 3004
- LOOP_DETECTED 3005
- ELECTION_LOST 4003
- Permanent failures 5001-5999 except 5002, 5003 and 5031.

Existing failure handling mechanism is enhanced such that the subscriber can be allowed to browse for a pre-configured amount of interim-volume and/or interim-time if OCS becomes unreachable due to transport connection failure or gives an impression that OCS is unreachable owing to slow response for Diameter request messages.

The purpose of this feature is to support Gy based data sessions in the event of an OCS outage. Diameter client allows the user's data session to continue for some fixed quota and then retries the OCS server to restore normal functionality. This feature adds more granularity to the existing failure handling mechanism.

With the implementation of this feature, Gy reporting during outages is supported. A temporary time and/or volume quota is assigned to the user in the event of an OCS outage which will be used during the outage period.

When the OCS returns to service, the GW reports all used quota back to OCS and continues with normal Gy reporting.

For each DCCA-service, CLI control is available for the following options:

- Interim quota volume (in bytes) and quota time (seconds). Both values will apply simultaneously, if configured together and if either quota time or quota volume is exhausted, the Diameter client retries the OCS.
- Option to limit the number of times a session can be assigned a temporary quota. If the user exceeds this amount, the session will be terminated/converted to postpaid.

The quota value is part of the dcca-service configuration, and will apply to all subscribers using that dcca-service. The temporary quota will be specified in volume (bytes) and/or time (seconds) to allow enforcement of both quota tracking mechanisms individually or simultaneously.

When a user consumes the interim total quota or time configured for use during failure handling scenarios, the GW retries the OCS server to determine if functionality has been restored. In the event that services have been restored, quota assignment and tracking will proceed as per standard usage reporting procedures. Data used during the outage will be reported to the OCS.

In the event that the OCS services have not been restored, the GW re-allocates the configured amount of quota and/or time to the user. The GW reports all accumulated used data back to OCS when OCS is back online. If multiple retries and interim allocations occur, the GW reports quota used during all allocation intervals. This cycle will continue until OCS services have been successfully restored, or the maximum number of quota assignments has been exhausted.

Support for OCS unreachable CLI commands is added under Diameter Credit Control Configuration mode.

For the P-GW/XGW/GGSN, this behavior will apply to all APNs and subscribers that have online charging enabled by the PCRF. In the HA, this behavior will apply to all users that have online charging enabled by the AAA. Settings will be applied to the dcca-service.

The following enhancements are implemented as part of the Assume Positive Gy feature:

- Configurable per error code treatment to enter assume positive mode
- Graceful session restart upon receipt of a 5002 error



Important Note that the Graceful session restart feature is customer specific. For more information contact your Cisco account representative.

Configurable per Error Code Treatment

This feature allows the customers to configure error result codes using the CLI command "**servers-unreachable behavior-triggers**" that will trigger entering assume positive mode on the fly for CCR-Initial and CCR-Update messages. CCR-Terminate message is currently not supported.

Any error result codes from the range 3xxx to 5xxx can be specified using the CLI commands. This feature has been implemented to provide more flexibility and granularity in the way assume positive mode is triggered for error result codes.

Graceful Session Restart

Graceful session restart upon receipt of a 5002 error code is supported for server retried CCR-U messages during assume positive state. Also, any unreported usage from the time, server retried CCR-U sent till CCA-I is received, will be reported immediately by triggering CCR-U with usages for the same.



Important Note that the Graceful session restart feature is customer specific. For more information contact your Cisco account representative.

Any pending updates are aborted once CCA-U with 5002 is received from the server. Also CCR-U is triggered immediately following session restart only if there are any unreported usages pending.



Important When the server responds with 5002 error result code, it does not include any granted service units for the requested rating groups.

For more information on the commands introduced in support of this feature, see the *Credit Control Configuration Mode Command* chapter in the *Command Line Interface Reference*.

Enhancement to OCS Failure Reporting for Gy

Feature Description

When Cisco-Event-Trigger-Type AVP is installed by PCRF in CCA-I, CCA-U or in RAR messages with value CREDIT_CONTROL_FAILURE (5), then the Cisco-Event grouped AVP is sent by the P-GW to PCRF in CCR-U message with the exact value of OCS failure code. This trigger is sent only when Gy failure occurs and based on the configuration (Credit-Control-Failure-Handling), the 'Continue' action is taken and Gy session moves to Offline state.

With this enhancement, the exact failure code is reported to the PCRF instead of the range. For example, when the Cisco-Event-Trigger-Type is CREDIT_CONTROL_FAILURE (5) and OCS failure code is 3002 in CCA-U, then in CCR-U towards PCRF Cisco-CC-Failure-Type (as part of grouped AVP Cisco-Event) is sent with a value of 3002.

Addition of Server Unreachable Field in CDR

Feature Description

When the Online Charging System (OCS) sends negative messages, transport connection fails between the Policy and Charging Enforcement Function (PCEF) and the OCS. The connection error causes session establishment failure and prevents subscribers from the use of services. The following procedures are used to overcome the connection errors:

- **Failure Handling (FH):** The existing FH mechanism operates if the diameter session failover is present, allows the system to choose whether to continue the session and convert to offline, or to terminate the session when a connection or message-level error occurs.
- **Server Unreachability (SU):** This failure handling mechanism provides more granular control over failure procedures. In addition to the session after the message- and connection-level (transport) failures,

this mechanism is used when the responses are slow from the OCS. It also provides the options to either continue the session for a specific time duration or quota exhaustion before termination.

To use the configured server and interim quota (volume and time), SU retries before a session is converted to offline or gets terminated.

When **gtp attribute servers-unreachable** is configured under gtp group and the SU feature is enabled then, serversUnreachableContinue or serversUnreachableTerminate in interim or final CDR allows the following process flow:

1. SU failure is triggered.
2. CDR is generated.
3. Based on the SU configuration in Call Control Profile, the generated CDR contains the serversUnreachableContinue or serversUnreachableTerminate fields.

The following table describes the serversUnreachable fields in the CDR.

Table 64: ServersUnreachable Fields in CDR

Field Name	Description	Tag	Format	Size	ASN1 Code
serversUnreachableContinue	When servers unreachable procedure is executed, element is present.	256	Boolean	1	0x9f8200
serversUnreachableTerminate	When servers unreachable procedure is executed, element is present.	257	Boolean	1	0x9f8201

Table 65: ServersUnreachable CDR Fields in ACS Configuration

SU Configuration	SU Detected Fields during Interim State	SU Detected Fields After End of Interim State	SU not Detected Fields (normal call with Gy)
server-unreachable initial-request terminate	When a CDR field is triggered differently, do not include the SU terminate field since it is an interim CDR <ul style="list-style-type: none"> • SU continue is FALSE • SU Terminate is FALSE in final CDR 	<ul style="list-style-type: none"> • SU continue is FALSE • SU Terminate is TRUE in final CDR 	<ul style="list-style-type: none"> • SU continue is FALSE • SU Terminate is FALSE in final CDR

server-unreachable update-request terminate	When a CDR field is triggered differently, do not include the SU terminate field since it is an interim CDR <ul style="list-style-type: none"> • SU continue is False • SU Terminate is False in final CDR 	<ul style="list-style-type: none"> • SU continue is True in both interim and final CDR • SU Terminate is False in final CDR 	<ul style="list-style-type: none"> • SU continue is False • SU Terminate is False in final CDR
server-unreachable initial-request continue	<ul style="list-style-type: none"> • SU continue is False • SU Terminate is False in final CDR 	<ul style="list-style-type: none"> • SU continue is True in both interim and final CDR • SU Terminate is False in final CDR 	<ul style="list-style-type: none"> • SU continue is False • SU Terminate is False in final CDR
server-unreachable update-request continue	<ul style="list-style-type: none"> • SU continue is False • SU Terminate is False in final CDR 	<ul style="list-style-type: none"> • SU continue is True in both interim and final CDR • SU Terminate is False in final CDR 	<ul style="list-style-type: none"> • SU continue is False • SU Terminate is False in final CDR

For more information, refer to the Gy chapter in the *PGW Administration Guide*.

Adding Server Unreachable Field in CDR

Use the following configuration commands to add the server unreachable field in CDR:

```
configure
context context_name
  gtpv group group_name
    gtpv attribute servers-unreachable
  end
```

NOTES:

- **gtpv attribute servers-unreachable**: Specifying this option includes the optional field **ServersUnreachablesContinue** or **ServersUnreachablesTerminate** in the CDR.

Monitoring and Troubleshooting

This section provides information to monitor and troubleshoot this feature using show commands.

Show Commands and Outputs

This section provides information regarding show command and their outputs in support of this feature.

show gtp group name <group name>

Field	Description
Servers Unreachable present	Displays "Yes" or "No" to indicate the presence of servers unreachable element.

Backpressure Handling

Diameter base (Diabase) maintains an outbound stream. When an application wants to write a message into a socket, the message handle of those messages are stored in the outbound stream. Only on receiving the response to the corresponding request, the stored message handle is removed from the outbound stream. In order to rate-limit the message transactions based on the responses received from the server, ASR 5500 maintains a limit on the number of messages stored in the outbound stream. This is done using "max-outstanding <>" CLI (default value is 256). If the number of messages created by the application exceeds the max-outstanding limit, diabase sends a 'Backpressure' indication to the application to wait till it receives a decongestion indication from diabase to try again.

On receiving a response from the server, the corresponding request message handle will be removed from the outbound stream, creating a slot for another message to be written by the application. In order to intimate this slot availability, decongestion notification is sent to the registered application. The application in turn loops through all sessions and processes the pending trigger to be sent.

When the application loops through the sessions in the system, it traverse the sessions in a sorted order and checks each session whether it has to send a pending CCR-Initial or CCR-Terminate or CCR-Update. When the first session gets the slot to fill the outbound stream, it writes the message into the stream. Now the slot gets back into filled state, reaching the max-outstanding limit again. So the rest of the sessions will still continue to be in backpressured state.

Backpressured request like Credit-Control-Initial and Credit-Control-Terminate are given higher priority over Credit-Control-Update as they are concerned with the creation or termination of a session. So on top of the decongestion notification, DCCA has some internal timers which periodically try to send the message out. So in case of heavy backpressure condition, the probability of CCR-I or CCR-T being sent out is more than CCR-U.

Gy Backpressure Enhancement

This feature facilitates maintaining a list of DCCA sessions that hit backpressure while creating a message i.e., backpressured list, eliminating the current polling procedure. This will maintain a single queue for all types of messages (CCR-I, CCR-U, CCR-T, CCR-E) that are backpressured. The messages will be sent in FIFO order from the queue.

After processing a session from the backpressure queue DCCA will check for the congestion status of the peer and continue only if the peer has empty slots in the outstanding message queue to accommodate further CCRs.

CPU utilization is very high if the max-outstanding count is low and network is congested.

All DCCA sessions associated with the CCR messages that are triggered BACKPRESSURE (when max-outstanding has been reached) will be queued in backpressure list which is maintained per ACS manager instance (credit-control) level.

This list will not have any specific configurable limits on the number of sessions that will be queued in it. This is because there is an inherent limit that is already present which is dependent on the number of subscriber/DCCA sessions.

With this new separate backpressured list, CPU utilization will come down under high backpressure case.

Gy Support for GTP based S2a/S2b

For WiFi integration in P-GW, Gy support is provided for GTP based S2a/S2b. This implementation is in compliance with standard Rel-11 non-3GPP access spec of 32.399: S5-120748 S5-131017 S5-143090.

As part of this enhancement, the following AVP changes are introduced:

- Added TWAN as a new enum value for Serving-Node-Type AVP
- Added a new Diameter AVP "TWAN-User-Location-Info". This is a grouped AVP and it contains the UE location in a Trusted WLAN Access Network (TWAN): BSSID and SSID of the access point.

The TWAN AVPs will be effective only for 3GPP release 11 and it is added only to the standard Gy dictionary. That is, the TWAN AVP will be included in CCR-I/CCR-U/CCR-T messages only when the CLI command "**diameter update-dictionary-avps 3gpp-rel11**" is configured.

Generating OOC/ROC with Changing Association between Rule and RG

The existing Gy implementation prevents duplicate Out-of-Credit (OOC) / Reallocation of Credit (ROC) report for the same rule to the PCRF. Subscriber throttling with the same rule with different Rating-Group across OOC event does not work. To overcome this, the following implementation is considered:

When a Rating-Group runs out of credit, OOC is sent to all rules that are currently associated with that Rating-Group. This is done irrespective of whether that rule was already OOC'd or not. Similarly, when a Rating-Group gets quota after being in OOC state, a ROC is sent to all rules that are currently associated with that Rating-Group. This is done irrespective of whether that rule was already ROC'd or not.

The rule level status bits are no longer used to avoid similar back-to-back OOC/ROC events. Now, the triggering of OOC/ROC events will solely be dependent on the MSCC state and triggers.

Customers might see an increase in OOC/ROC events on Gx if they change the association of the rule and RG or if they use the Override feature.

Static Rulebase for CCR

An APN/subscriber can have a single rulebase applied to it, but allowing a static rulebase configuration to always pass a different or same rulebase to the OCS through CCR messages.

A new CLI command "**charging-rulebase-name rulebase_name**" has been introduced under Credit Control (CC) group to override/change the rulebase name present in APN/subscriber template, in the CCR AVP "Charging-Rule-Base-Name". The rulebase value configured in CC group will be sent to OCS via CCR. If this CLI command is not configured, then the rulebase obtained from APN/subscriber template will be sent to OCS.

The configured value of rulebase under CC group is sent in all CCR (I/U/T) messages. This implies that any change in rulebase value in CC group during mid-session gets reflected in the next CCR message.

This feature, when activated with the CLI command, reduces the complication involved in configuration of services like adding and removing services per enterprise on the OCS system.

CC based Selective Gy Session Control

This section describes the overview and implementation of the Selective Gy Session Control feature based on Charging Characteristics (CC) profile of the subscriber.

This section discusses the following topics for this feature:

- [Feature Description, on page 660](#)
- [Configuring CC based Selective Gy Session Control, on page 661](#)
- [Monitoring and Troubleshooting the Selective Gy Session Control Feature, on page 662](#)

Feature Description

The functionality that allows users to configure certain Charging Characteristics (CC) values as prepaid/postpaid is available for GGSN service. Now, this functionality is extended to P-GW service.

To enable/disable Gy session based on the CC value received, the APN configuration is extended so that additional credit-control-groups/prepaid prohibited value can be configured for each of the CC values.

The **cc profile cc-profile-index prepaid prohibited** CLI command is used to configure the CC values to disable Credit-Control based charging. The P-GW/GGSN/SAEGW service subscriber sessions using this APN, can use this configuration to stop the triggering of Gy messages towards the OCS.

The UE provides the charging characteristics value and the active subscriber is connected through an APN. The CC index mapping is done for a corresponding CC group/prepaid prohibited value configured under the APN. Depending on the match, the Gy session is enabled or disabled towards the OCS.

The Session controller stores/updates the APN configuration in the AAA manager. During the session setup, the session manager fills the CC value received in session authenticate request, and sends it to AAA manager. The AAA manager matches this against the locally stored APN configuration, and selects the desired credit-control-group/prepaid-prohibited configuration for the session. Then the session manager passes this credit-control-group/prepaid-prohibited information received from the AAA manager to ACS manager.

When the local authentication (session setup request) is done, the credit-control group with the matching charging characteristic is selected and used. If there is no matching charging characteristic configuration found for the credit-control group selection, then the default credit-control group for the APN is selected.

When a particular CC is configured as postpaid, any session with this CC does not trigger Gy connection. Any change in the CC during the lifetime of session is ignored.

The CC based Gy Session Controlling feature is applicable only for the CC value received via GTP-Auth-Request, and during the session establishment. The CC value updated via AAA/PCRF after the session setup will not cause any change in already selected credit-control group. Once the credit-control group is selected after session setup, this feature is not applicable.

Diameter Error Code and Counters

SaMOG supports Diameter error code counters for all transactions and diameter interfaces on SaMOG (Web-auth) services through P-GW LBO module on various StarOS platforms ASR5500/ASR5700.

The following set of result code specific counters are available for the responses received from the OCS (Online Charging System), on Gy interface. DCCA (Diameter Credit Control Application) is the protocol used on the Gy interface.

Table 66: Result Code Specific Counters

Error Category	Result Code	Result Code Value
Transient Failures [4XXX]	DIAMETER_END_USER_SERVICE_DENIED	4010
	DIAMETER_CREDIT_LIMIT_REACHED	4012
Permanent Failures [5XXX]	DIAMETER_RATING_FAILED	5031

Relationships to Other Features

This feature can also be used when the CC profile configuration is enabled through the GGSN service. When the CC profile is configured under APN service and GGSN service, the prepaid prohibited configuration for the matching CC profile is applied irrespective of the services.

Limitations

The following are the limitations of this feature:

- One charging characteristic value can be mapped to only one credit-control-group/prepaid-prohibited configuration within one APN.
- The charging-characteristic based OCS selection is possible only during the session-setup. Once the credit-control-group is selected (after session setup), this feature is not applicable.

Configuring CC based Selective Gy Session Control

The following sections provide the configuration commands to configure the Gy Session Control feature based on the CC profile of the subscriber.

Configuring CC Value

The following commands are used to configure Charging Characteristic values as postpaid/prepaid to disable/enable Gy session towards the OCS.

```

configure
  context context_name
    apn apn_name
      cc-profile { cc_profile_index | any } { prepaid-prohibited |
credit-control-group cc_group_name }
    end

```

Notes:

- *cc_profile_index*: Specifies the CC profile index. *cc_profile_index* must be an integer from 0 through 15.
- **any**: This keyword is applicable for any non-overridden cc-profile index. This keyword has the least priority over specific configuration for a CC profile value. So, configuring **any** keyword will not override other specific configurations under APN.
- **prepaid-prohibited**: Disables prepaid Gy session for the configured profile index.
- *cc_group_name*: Specifies name of the credit control group as an alphanumeric string of 1 through 63 characters.

- **no cc-profile** *cc_profile_index*: This command falls back to "any" cc-profile behavior irrespective of the CC profile index value configured.

Verifying the Selective Gy Session Control Configuration

Use the following command in Exec mode to display/verify the configuration of Selective Gy Session Control feature.

```
show configuration
```

Monitoring and Troubleshooting the Selective Gy Session Control Feature

This section provides information regarding show commands and/or their outputs in support of the Selective Gy Session Control feature.

show active-charging sessions

The "Credit-Control" field that appears as part of the **show active-charging sessions [callid | imsi | msisdn]** command output enables the user to determine the credit control state as "On" for online charging enabled session or "Off" for prepaid prohibited session and monitor the subscriber session.

Credit-Control Group in Rulebase Configuration

This section describes the overview and implementation of the Credit-Control (CC) Group Selection based on the rulebase of the subscriber.

This section discusses the following topics for this feature:

- [Feature Description, on page 662](#)
- [Configuring Credit-Control Group in Rulebase, on page 663](#)
- [Monitoring and Troubleshooting the CC-Group Selection in Rulebase, on page 664](#)

Feature Description

This feature is introduced to customize the behavior for different types of subscribers in the Assume Positive scenario. This customization is made by enabling the users to specify a desired Credit-Control (CC) group based on the rulebase dynamically selected by PCRF.

Typically, the behavior for Assume Positive is configured within the CC group. Now, the CC group selection functionality is extended to rulebase configuration.

This feature is explicitly required in scenarios where IMSA was not used, AAA server could not send CC group during authentication, and only a single APN/subscriber-profile was used for all the subscribers. In such situations, this feature targets to provide a premium CC group within rulebase to enable premium treatment to subscribers based on their types.

This feature introduces a new configurable option inside the rulebase configuration, so that the users can specify the desired CC group whenever the rulebase is selected during the subscriber session setup. This configured CC group overrides or has a higher priority than the CC group configured within the subscriber profile/APN. If the AAA or PCRF server sends the CC-Group AVP, the CC group value defined through the AVP overrides the rulebase configured CC group.

When this feature is enabled, the configuration allows specifying an association between the rulebase name and the CC group so that when a premium subscriber connects, a premium rulebase and a premium CC group are selected.



Important Mid-session configuration change will not impact the existing subscribers in the system. This configuration change will be effected only to the new sessions.

Implementing this new configuration option enables different types of Assume-Positive behavior for subscribers based on the available quota. This results in achieving preferential treatment for premium customers.

The precedence order for selection of the CC group is defined as:

- PCRF provided CC group
- AAA provided CC group
- Rulebase configured CC group
- Subscriber Profile/APN selected CC group
- Default Credit-Control group



Important This feature should not be used when there is an option for AAA server to send the CC group during authentication process. If during the authentication, AAA server sends a CC group, and the rulebase selected has a CC group defined within, then the rulebase defined CC group is selected for the session.

Limitations

There are no limitations or restrictions with this feature. However, it is important to keep in mind the precedence order for CC group selection.

Configuring Credit-Control Group in Rulebase

The following sections provide the configuration commands to configure the Credit-Control Group based on the rulebase of the subscriber.

Defining Credit-Control Group

The following commands are used to configure a desired Credit-Control group name when using the rulebase selected by PCRF.

```
configure
require active-charging
active-charging service service_name
    rulebase rulebase_name
        credit-control-group cc_group_name
    end
```

- *cc_group_name*: Specifies name of the credit control group as an alphanumeric string of 1 through 63 characters.

- **no credit-control-group**: Removes the previously configured CC group from the rulebase configuration. This is the default setting.
- This CLI configuration is applicable only during the session setup. Mid-session change in the CC group is not allowed.
- This is an optional CLI configuration, and used only when customized Assume Positive behavior is required for subscribers.
- If this CLI command is configured, the selection of the CC group will be based on the precedence order. That is, the rulebase defined CC group has higher precedence over the CC group value specified in the Subscriber/APN profile.
- If the CC group configuration is not present in the rulebase, the default subscriber/APN profile configuration is applied.

Verifying the Credit-Control Group Configuration

Use the following command in Exec mode to display/verify the configuration of CC group in rulebase.

```
show configuration verbose
```

Monitoring and Troubleshooting the CC-Group Selection in Rulebase

This section provides information regarding show commands and/or their outputs in support of this feature.

show active-charging sessions full

The output of this show CLI command displays the selected credit-control-group for the session. The output details are useful in verifying and troubleshooting the issues with this feature.

show configuration errors

This show CLI will list an error if the credit-control group that is configured inside the rulebase is not defined.

show configuration verbose

This command will show the "credit-control-group" option specified for the rulebase. For troubleshooting purpose, capture the output of **show configuration verbose** and **show subscribers full** along with the **monitor-protocol** output containing "Radius Access-Accept".

Combined CCR-U Triggering for QoS Change Scenarios

When default EPS bearer QoS and APN AMBR values are changed, P-GW sends update request to access side to change default bearer and APN AMBR in a single message. P-GW will apply APN AMBR and default bearer QoS accordingly and will send only one CCR-U on Gy for this change condition.



Important This behavior change is applicable only to P-GW calls. This change has no impact to the Rf/CDR records, and GGSN/P-GW eHRPD calls.

Also, note that this behavior is not applicable for split TFT case (QoS + APN AMBR + TFT) wherein multiple Update Bearer Requests are sent towards the access side.

Re-activating Offline Gy Session after Failure

This section describes the feature to re-enable Offline Gy session on detecting failure at Diameter Credit Control Application.

This section includes the following topics:

Feature Description

With this feature, a mechanism to re-enable the Offline Gy session back to Online charging, based on indication from PCRF is introduced. Upon receiving the Online AVP from PCRF, the gateway will establish the Gy session.

There was no provision to activate Gy once the session was marked as Offline. On detecting failure at Diameter Credit Control Application, the configured Credit Control Failure Handling (CCFH) action would be taken. Once the Gy session has taken the CCFH Continue action, the subscriber session could not be retried/re-enabled.

The Online AVP in the Charging-Rule-Definition is considered as the trigger/indication from PCRF to enable the Offline Gy session, after the CCFH Continue action been taken. The Online AVP at the command level from PCRF will not be considered as a trigger to enable the Offline Gy session. As per 3GPP 29.212 (release 12.12.0), the Online AVP (1009) is an optional AVP inside the Charging-Rule-Definition grouped AVP (1003).

Limitations and Restrictions

This section lists the limitations and configuration restrictions with this feature:

- This feature is limited only to Volume Quota mechanism. Special handling is not done for Quota-Validity-Time (QVT) and Quota-Hold-Time (QHT) timers. When the Gy session goes offline and comes back again, these timers are not started. The timers will be started only when the next CCA-U provides the information from OCS.
- When the Gy session is marked Online, CDR closure is not required and this is handled by the billing system.
- This feature is not extended to the event-based credit-control sessions.
- When the CCFH action is taken due to MSCC level failure, the existing behavior is retained and the following behavior is observed:
 - CCFH Continue – Continue the category (MSCC) without charging at Gy and this is applicable to the MSCC (not to the entire session). The MSCC state in the output of the **show active-charging sessions full** command will display "No Charge".
 - CCFH Terminate/Retry-and-Terminate – The bearer gets terminated.
- When the Result-Code 4011 (DIAMETER_CREDIT_CONTROL_NOT_APPLICABLE) is received at MSCC level, the category is marked Free-of-Charge and no further accounting for this category is done. When this result code is received at command level, the Gy session is made Offline. The Offline Gy session can be made Online again using the Online AVP from PCRF and the accounting will resume normally (CCR-U will be seen at OCS for this session).
- When CCFH Continue is configured and CCR-I failure occurs, the following behavior is observed:
 - Diabase Error – When diabase error (TCP connection down) occurs, the Gy session is marked Offline and the session-state is maintained (session-ID created). When re-enabling the Gy session, a new CCR-I is sent immediately (without waiting for data).

- Response Timeout – When the response timeout happens, if the CCR-I is sent at session-setup and the session-setup timeout happens before response-timeout, then the bearer itself will be terminated. The **diameter send-crri traffic-start** configuration can be used optionally so that the CCR-I timeout does not affect the bearer creation.
- When the Gy session goes Offline due to CCR-I response timeout and the Gy session is marked Online, the same Session-ID will be used.
- If the Gy session went offline due to CCR-I error response, the session-information is deleted (next session-ID used will be different).
- In case of rule-movement across bearers (LTE to WiFi or vice-versa) where the Online rule is moved/associated to an existing bearer, the status of the Gy session is not changed.
- The trigger for marking the Offline Gy Session to Online is only based on the Online AVP received from the PCRF in the Charging-Rule-Definition.

Configuring Offline Gy Session after Failure

The following section provides the configuration commands to re-enable the offline Gy session.

Re-enabling Offline Gy Session

Use the following configuration to re-enable offline Gy session after failure.

```
configure
  active-charging service service_name
    credit-control
      [ no ] offline-session re-enable
    end
```

Notes:

- When **offline-session re-enable** is configured and the PCRF installs/modifies a rule with "Online" AVP value set to 1, then the Offline DCCA will be marked Online.
- The default configuration is **no offline-session re-enable**. This feature is disabled by default and when disabled only the **show configuration verbose** command will display this configuration.

Verifying the Configuration

Use the following command to verify the offline/online state transition timestamp:

```
show active-charging sessions full
```

Monitoring and Troubleshooting the Offline Gy Session after Failure

This section provides information regarding show commands and/or their outputs in support of this feature.

The following operations should be performed to troubleshoot any failure related to this feature:

- The CLI output of the **show active-charging sessions full** command can be verified. The "Last State Change Time" field indicates the timestamps at which a session went Offline and came back Online.
- The messages from **monitor subscriber next-call** command can be enabled with "verbosity 3" to analyze the message exchanges happening for the subscriber.

- The "acsmgr" and "debug" level logs can be enabled for further debugging.

show active-charging sessions full

The following new fields are added to the output of this command to display the state transition timestamp:

- Last State Change Time:
 - Offline/Online – The Offline timestamp is updated when the Gy session goes Offline. The Online timestamp is updated when the session is back Online.

Suppress AVPs

This feature adds enhancement to the *Support MVNO Information in Gx, Gy and CDRs* feature.

Feature Description

This feature adds enhancement to the *Support MVNO Information in Gx, Gy and CDRs* feature. SAEGW sends MVNO-Reseller-ID and MVNO-Subclass-ID AVPs in the Gy messages towards the OCS and CDR, whenever these AVPs are received by SAEGW from the PCRF.

With this enhancement, this behavior is now CLI controlled and a new CLI command has been introduced to suppress the AVPs being sent in the Gy interface.

Old Behavior: Reseller-id and subclass-id AVPs were sent in Gy when the same were received from PCRF for the ATT dictionary.

New Behavior: New CLI command **suppress_avp** has been added which allows to suppress the Reseller-id and subclass-id AVPs.

Command Changes

suppress_avp

New CLI command has been added to the Credit Control Group configuration mode to suppress the AVPs. Configuring this CLI command would suppress the MVNO-subclass-id and MVNO-Reseller-Id AVPs.

```

configure
  active-charging service <acs_service_name>
  credit-control group <group_name>
    diameter suppress-avp reseller-id subclass-id
    [ no | default ] diameter suppress-avp reseller-id subclass-id
  end

```

Notes:

- **no:** Disables AVP suppression. Whenever PCRF sends the MVNO-subclassid and MVNO-Reseller-id AVPs in the Gx interface, the same is sent in the Gy message.
- **default:** Sets the default configuration. AVPs are not suppressed by default. Whenever PCRF sends the MVNO-subclassid and MVNO-Reseller-id AVPs in the Gx interface, the same is sent in the Gy message.
- **suppress-avp:** Suppresses both MVNO-subclassid and MVNO-Reseller-id AVPs.
- **reseller-id:** Suppresses the MVNO-Reseller-Id AVP.

- **subclass-id**: Suppresses the MVNO-Sub-Class-Id AVP.

Performance Indicator Changes

show configuration

This command has been modified to display the following output:

```
credit-control group default
  diameter origin endpoint sundar
  diameter peer-select peer minid1 secondary-peer minid2
  diameter session failover
  diameter dictionary dcca-custom32
  failure-handling initial-request continue
  failure-handling update-request continue
  diameter dynamic-rules request-quota on-traffic-match
  diameter suppress-avp reseller-id subclass-id
```

Configuring Gy Interface Support

To configure Gy interface support:

-
- Step 1** Configure the core network service as described in this Administration Guide.
 - Step 2** Configure Gy interface support as described in the sections [Configuring GGSN / P-GW / IPSP Gy Interface Support, on page 668](#) and [Configuring HA / PDSN Gy Interface Support, on page 669](#).
 - Step 3** Configure Event-based Gy support as described in [Configuring PLMN and Time Zone Reporting, on page 671](#).
 - Step 4** *Optional.* Configure OCS Unreachable Failure Handling Feature or Assume Positive for Gy Feature as described in [Configuring Server Unreachable Feature, on page 672](#).
 - Step 5** *Optional.* Configure Static Rulebase for CCR as described in [Configuring Static Rulebase for CCR, on page 673](#).
 - Step 6** *Optional.* Configure Gy for GTP based S2a/S2b as described in [Configuring Gy for GTP based S2a/S2b, on page 673](#).
 - Step 7** Save your configuration to flash memory, an external memory device, and/or a network location using the Exec mode command **save configuration**. For additional information on how to verify and save configuration files, refer to the *System Administration Guide* and the *Command Line Interface Reference*.

Important Commands used in the configuration examples in this section provide base functionality to the extent that the most common or likely commands and/or keyword options are presented. In many cases, other optional commands and/or keyword options are available. Refer to the *Command Line Interface Reference* for complete information regarding all commands.

Configuring GGSN / P-GW / IPSP Gy Interface Support

To configure the standard Gy interface support for GGSN/P-GW/IPSP, use the following configuration:

```
configure
  context <context_name>
    diameter endpoint <endpoint_name>
      origin realm <realm>
```

```

        origin host <diameter_host> address <ip_address>
        peer <peer> realm <realm> address <ip_address>
        exit
    exit
active-charging service <ecs_service_name>
    credit-control [ group <cc_group_name> ]
        diameter origin endpoint <endpoint_name>
        diameter peer-select peer <peer> realm <realm>
        diameter pending-timeout <timeout_period>
        diameter session failover
        diameter dictionary <dictionary>
        failure-handling initial-request continue
        failure-handling update-request continue
        failure-handling terminate-request continue
        exit
    exit
context <context_name>
    apn <apn_name>
        selection-mode sent-by-ms
        ims-auth-service <service>
        ip access-group <access_list_name> in
        ip access-group <access_list_name> out
        ip context-name <context_name>
        active-charging rulebase <rulebase_name>
        credit-control-group <cc_group_name>
    end

```

Notes:

- For information on configuring IP access lists, refer to the *Access Control Lists* chapter in the *System Administration Guide*.
- For more information on configuring ECS ruledefs, refer to the *ACS Ruledef Configuration Mode Commands* chapter in the *Command Line Interface Reference*.
- For more information on configuring ECS charging actions, refer to the *ACS Charging Action Configuration Mode Commands* chapter in the *Command Line Interface Reference*.
- For more information on configuring ECS rulebases, refer to the *ACS Rulebase Configuration Mode Commands* chapter in the *Command Line Interface Reference*.

Configuring HA / PDSN Gy Interface Support

To configure HA / PDSN Gy interface support, use the following configuration:

```

configure
    context <context_name>
        diameter endpoint <endpoint_name>
            origin realm <realm>
            origin host <diameter_host> address <ip_address>
            peer <peer> realm <realm> address <ip_address>
            exit
        exit

```

```

active-charging service <ecs_service_name>
  ruledef <ruledef_name>
    ip any-match = TRUE
    exit
  charging-action <charging_action_name>
    content-id <content_id>
    cca charging credit rating-group <rating_group>
    exit
  rulebase <rulebase_name>
    action priority <action_priority> ruledef <ruledef_name>
charging-action <charging_action_name>
  exit
  credit-control [ group <cc_group_name> ]
    diameter origin endpoint <endpoint_name>
    diameter peer-select peer <peer> realm <realm>
    diameter pending-timeout <timeout>
    diameter session failover
    diameter dictionary <dictionary>
    failure-handling initial-request continue
    failure-handling update-request continue
    failure-handling terminate-request continue
    pending-traffic-treatment noquota buffer
    pending-traffic-treatment quota-exhausted buffer
    exit
  exit
context <context_name>
  subscriber default
    ip access-group <acl_name> in
    ip access-group <acl_name> out
    ip context-name <context_name>
    active-charging rulebase <rulebase_name>

    credit-control-group <cc_group_name>
  end

```

Notes:

- For information on configuring IP access lists, refer to the *Access Control Lists* chapter in the *System Administration Guide*.
- For more information on configuring ECS ruledefs, refer to the *ACS Ruledef Configuration Mode Commands* chapter in the *Command Line Interface Reference*.
- For more information on configuring ECS charging actions, refer to the *ACS Charging Action Configuration Mode Commands* chapter in the *Command Line Interface Reference*.
- For more information on configuring ECS rulebases, refer to the *ACS Rulebase Configuration Mode Commands* chapter in the *Command Line Interface Reference*.

Configuring PLMN and Time Zone Reporting

PLMN and Time Zone Reporting feature requires a credit-control group to be defined in the APN or subscriber configuration or there must be a default credit-control group configured. The following CLI commands are available to enable/disable PLMN and Time Zone Reporting feature.

To enable PLMN and Time Zone Reporting through subscriber-template, use the following configuration:

```
configure
  context <context_name>
    subscriber name <subscriber_name>
      dns primary <primary_ipaddress>
      dns secondary <secondary_ipaddress>
      ip access-group test in
      ip access-group test out
      ip context-name <context_name>
      credit-control-client event-based-charging
      active-charging rulebase <rulebase_name>
    exit
  end
```

Notes:

- The **credit-control-client event-based-charging** command should be used to enable PLMN and Time Zone Reporting.

For more information on configuring PLMN and Time Zone Reporting feature, refer to the *Command Line Interface Reference*.

To enable PLMN and Time Zone Reporting through APN template, use the following configuration:

```
configure
  context <context_name>
    apn <apn_name>
      selection-mode sent-by-ms
      accounting-mode none
      ip access-group test in
      ip access-group test out
      ip context-name <context_name>
      ip address pool name <pool_name>
      credit-control-client event-based-charging
      active-charging rulebase <rulebase_name>
    exit
  end
```

Rest of the parameters needed for Event-based Gy such as dictionary, endpoint will be picked from the credit-control group.

In a scenario where the triggers are configured through the CLI command and another set of triggers are also received from Gx, then the triggers from Gx will have a higher priority.

Configuring Server Unreachable Feature

The Server Unreachable feature requires a failure handling behavior to be defined in the Diameter Credit Control configuration. The following CLI commands are available to enable/disable OCS Unreachable Failure Handling feature.

To enable OCS Unreachable Failure Handling feature, use the following configuration:

```
configure
require active-charging
    active-charging service <service_name>
        credit-control
            servers-unreachable { initial-request | update-request
} { continue | terminate } [ { after-interim-volume <bytes> |
after-interim-time <seconds> } + server-retries <retry_count> ]
            servers-unreachable behavior-triggers { initial-request
| update-request } transport-failure [ response-timeout | tx-expiry ]
            servers-unreachable behavior-triggers initial-request
{ result-code { any-error | result-code [ to end-result-code ] } }
            servers-unreachable behavior-triggers update-request
{ result-code { any-error | result-code [ to end-result-code ] } }
        end
```



Important After you configure **configure**, **require active-charging**, **active-charging service <service_name>**, and **credit-control** CLI commands, you must save the configuration and then reload the chassis for the command to take effect. For information on saving the configuration file and reloading the chassis, refer to the *System Administration Guide* for your deployment.

Notes:

- This CLI command "**servers-unreachable { initial-request | update-request } { continue | terminate } [{ after-interim-volume ... }**" allows configuring interim-volume and interim-time in the following ways:
 - after-interim-volume <bytes> alone followed by server-retries.
 - after-interim-time <secs> alone followed by server-retries.
 - after-interim-volume <bytes> after-interim-time <secs> followed by server-retries.
- This CLI command "**servers-unreachable behavior-triggers**" is used to trigger the servers-unreachable failure handling at either Tx expiry or Response timeout (This CLI is similar to retry-after-tx-expiry in "**failure-handling update-request continue retry-after-tx-expiry**" command.).
- This CLI command "**servers-unreachable behavior-triggers initial-request { result-code { any-error | result-code [to end-result-code] } }**" is used to trigger the servers-unreachable failure handling based on the configured Diameter error result codes.

For more information on configuring this feature, refer to the *Command Line Interface Reference*.

Configuring Static Rulebase for CCR

To allow static configuration of rulebase name to be passed to OCS via CCR message, use the following configuration:

```
configure
  require active-charging
  active-charging service service_name
  credit-control group ccgroup_name
  charging-rulebase-name rulebase_name
  no charging-rulebase-name
end
```



Important After you configure **configure**, **require active-charging**, **active-charging service service_name**, and **credit-control group ccgroup_name** CLI commands, you must save the configuration and then reload the chassis for the command to take effect. For information on saving the configuration file and reloading the chassis, refer to the *System Administration Guide* for your deployment.

Notes:

- By default, the rulebase obtained from APN/subscriber template will be sent to OCS through the CCR message.

For more information on configuring this feature, refer to the *Command Line Interface Reference*.

Configuring Gy for GTP based S2a/S2b

To provide Gy Support for WiFi integration in P-GW for GTP based S2a/S2b, use the following configuration:

```
configure
  require active-charging
  active-charging service service_name
  credit-control group ccgroup_name
  diameter update-dictionary-avps 3gpp-rel11
  [ default | no ] diameter update-dictionary-avps
end
```

Notes:

- **3gpp-rel11**: Provides support for 3GPP Rel.11 specific AVPs in the standard Gy dictionary.

Gathering Statistics

This section explains how to gather Gy related statistics and configuration information.

In the following table, the first column lists what statistics to gather, and the second column lists the action to perform.

Statistics/Information	Action to perform
Complete statistics for ECS sessions.	show active-charging sessions full

Statistics/Information	Action to perform
Detailed information for the Active Charging Service (ACS)	show active-charging service all
Information on all rule definitions configured in the service.	show active-charging ruledef all
Information on all charging actions configured in the service.	show active-charging charging-action all
Information on all rulebases configured in the service.	show active-charging rulebase all
Statistics of the Credit Control application, DCCA.	show active-charging credit-control statistics
States of the Credit Control application's sessions, DCCA.	show active-charging credit-control session-states [rulebase <rulebase_name>] [content-id <content_id>]



CHAPTER 26

Gy Failure Handling Enhancement

- [Feature Summary and Revision History, on page 675](#)
- [Feature Description, on page 676](#)
- [How It Works, on page 676](#)
- [Configuring Gy Failure Handling, on page 677](#)
- [Monitoring and Troubleshooting the Gy Failure Handling, on page 677](#)

Feature Summary and Revision History

Summary Data

Applicable Product(s) or Functional Area	<ul style="list-style-type: none">• P-GW• SAEGW
Applicable Platform(s)	ASR 5500
Feature Default	Disabled - Configuration Required
Related Changes in This Release	Not Applicable
Related Documentation	<ul style="list-style-type: none">• <i>P-GW Administration Guide</i>• <i>SAEGW Administration Guide</i>

Revision History



Important Revision history details are not provided for features introduced before releases 21.2 and N5.5.

Revision Details	Release
A new option to continue the session, but drop the traffic, is introduced in the FH-template that is associated with a Credit Control Group. An existing CLI command is enhanced to enable the feature.	21.3
First introduced.	Pre 21.2

Feature Description

In releases prior to 21.3, the Gy failure-handling-template (FH-template) had no option to block the chargeable traffic while retaining the PDN session.

In 21.3 and later releases, "continue discard-traffic" option has been added to Gy failure-handling-template to block the chargeable traffic while retaining the PDN session.

How It Works

This section provides a brief overview of how this feature works:

- A new option to continue the session, but drop the traffic, is introduced in the FH-template that is associated with a Credit Control Group. An existing CLI command is enhanced to enable the feature.
- When the "continue discard-traffic" FH action is enforced, all traffic is blocked for the given DCCA session. The DCCA session refers to the PDN (and all bearers therein) or to a specific bearer. The matching bearers a DCCA session corresponds to, continues as it is for FH action "continue". Only the traffic that requires online charging is dropped.
- The "continue discard-traffic" status remains enforced unless a Rule modification or installation is received from the PCRF for a pure dynamic rule. The online AVP (online = 1) is sent eventually from the PCRF which resumes the Gy session for the given bearer (sub session). This behavior is based on the "offline-session re-enable" CLI that is available in the credit-control-group configuration mode.
- All traffic that requires online-charging is dropped.
- The charging action is identified and only if the charging action requires "online" charging, the corresponding drop action is taken.
- The "continue discard-traffic" status on a subscriber remains as is post recovery. Traffic is blocked after recovery as long as Gx does not re-enable the Gy session.



Note

- The **Gy Failure Handling Enhancement** feature works along with the *OCS Failure Reporting to PCRF* (introduced in Release 21.0) and the *Enhancement to OCS Failure Reporting for Gy* (introduced in Release 21.2) features. Refer to the respective *Release Change Reference* for additional information.
- When the CCFH/FH-Template is configured with Continue action (or this new FH-Template "continue-discard") and the corresponding action is being taken, then the reporting to the PCRF happens as per the *OCS Failure Reporting to PCRF* feature.

Configuring Gy Failure Handling

Use the following commands under the Diameter Failure Handling Template Configuration Mode to discard data traffic while retaining the subscriber session.

```
configure
failure-handling-template template_name
  msg-type { credit-control-initial | credit-control-terminate |
credit-control-update } failure-type any action continue discard-traffic
end
```

Notes:

- Use the **msg-type { credit-control-initial | credit-control-terminate | credit-control-update } failure-type any action continue discard-traffic** CLI command to specify the behavior if there is a communication failure with the prepaid server. If there are different failure handling configurations present within the template for the same message type, the action is applied as per the latest error encountered.
- The enhancement of "discard-traffic" is added to action "continue". This blocks data traffic while retaining the subscriber session.
- If previously configured, use the **no msg-type { credit-control-initial | credit-control-terminate | credit-control-update } failure-type any** CLI command to remove the configuration associated with the failure handling template.
- The "discard-traffic" keyword can only be configured along with "continue" action, and it takes affect when the respective failure occurs.
- This CLI option is disabled by default. The "discard-traffic" keyword needs explicit configuration if the respective discard action is desired.

Monitoring and Troubleshooting the Gy Failure Handling

This section provides information regarding monitoring and troubleshooting the feature.

Gy Failure Handling Show Command(s) and/or Outputs

This section provides information regarding show commands and/or their outputs in support of the feature.

show active-charging credit-control statistics

The output of this show command has been enhanced to display the following new field in support of this feature:

- Action-Drop:

Following is a partial sample output:

```
Failure Handling Stats:
  Action-Terminated:      0           Action-Continue:      0
  Offline Active Sessions: 0           Action-Drop:          0
```



CHAPTER 27

HSS and PCRF Based P-CSCF Restoration Support

This feature enables support for HSS-based and PCRF-based P-CSCF restoration that helps to minimize the time a UE is unreachable for terminating calls after a P-CSCF failure.

- [Feature Description, on page 679](#)
- [How It Works, on page 680](#)
- [Configuring the HSS/PCRF-based P-CSCF Restoration, on page 689](#)
- [Monitoring and Troubleshooting the HSS/PCRF-based P-CSCF Restoration, on page 691](#)

Feature Description

The P-CSCF restoration procedures were standardized to minimize the time a UE is unreachable for terminating calls after a P-CSCF failure. In compliance with 3GPP standard Release 13, this feature includes the following P-CSCF restoration mechanisms:

- HSS-based P-CSCF Restoration for Trusted/Untrusted WLAN Access (S2a/S2b)
- PCRF-based P-CSCF Restoration for LTE (S5/S8) and Trusted/Untrusted WLAN Access (S2a/S2b)



Important HSS-based P-CSCF Restoration was supported at P-GW for LTE (S5/S8) prior to StarOS release 21.0.

This feature provides support for both basic and extended P-CSCF Restoration procedures.

HSS-based P-CSCF Restoration for WLAN

If the P-CSCF restoration mechanism is supported, gateway indicates the restoration support to AAA server through Feature-List AVP in the Authorization Authentication Request (AAR) message sent over S6b. The Feature-List AVP is part of the Supported-Features grouped AVP. The Bit 0 of the Feature-List AVP is used to indicate P-CSCF Restoration support for WLAN.

During the P-CSCF Restoration, 3GPP AAA server, after having checked that the P-GW supports the HSS-based P-CSCF restoration for WLAN, sends a P-CSCF restoration indication to the P-GW over S6b in a Re-authorization Request (RAR) command. A new Diameter AVP “**RAR-Flags**” is encoded in the RAR message with the Bit 1 set, would indicate to the gateway that the AAA server requests the execution of HSS-based P-CSCF restoration procedures for WLAN.

The existing CLI command **diameter authentication** under AAA Group configuration is extended to encode P-CSCF Restoration feature as part of Supported-Features AVP in the AAR message.



Important Supported-Features will be sent in every AAR message for RAT type WLAN. Feature negotiation is required in every AAR. ReAuth AAR will also do the feature renegotiation.

Emergency PDN HSS based P-CSCF Restoration for S5/S8 will be performed if CLI is configured at P-GW service to support the restoration for emergency PDNs.

PCRF-based P-CSCF Restoration

PCEF supporting P-CSCF restoration mechanism indicates the restoration support in CCR-I message through the Supported-Features AVP. The 24th Bit of the Supported-Feature-List AVP indicates whether this mechanism is supported or not.

The existing CLI command **diameter encode-supported-features** in Policy Control configuration is extended to allow the negotiation of P-CSCF Restoration feature support with PCRF. A new Diameter AVP “**PCSCF-Restoration-Indication**” is introduced to indicate to PCEF that a P-CSCF Restoration is requested. This is achieved by setting AVP value to 0.

Supported-Features AVP is negotiated in CCR-I of all access types (eHRPD, P-GW, GGSN); however, Restoration trigger, if received, is ignored in eHRPD and GGSN.

Limitations

- As per the 3GPP standard specification, if S6b re-authorization request is used for P-CSCF Restoration for WLAN, then for extended P-CSCF Restoration the gateway may send authorization request with only mandatory AVPs. However, in the current implementation, ReAuth used for extended P-CSCF Restoration is a common authorization request of normal ReAuth. It will contain all the AVP of ReAuthorization AAR.
- For P-CSCF Restoration extension mechanism during P-CSCF ReDiscovery with P-CSCF FQDN, local DNS cache will be queried first. If FQDN is already present in local DNS cache, then DNS query will not be sent out to the DNS server and P-GW will immediately get the DNS response.

Since local DNS cache flush will not be done, operator should configure the cache accordingly.

Licensing

Use of P-CSCF Restoration requires that a valid license key be installed. Contact your local Sales or Support representative for information on how to obtain a license.

How It Works

- Restoration is supported for IPv4/IPv6/IPv4v6 calls.
- With extension, Restoration Support UBR will always go on default bearer.

- P-GW does not compare any of the stored values with the new updated P-CSCF IP addresses; it relies on the DNS provided/discovered values and forwards the P-CSCF IP addresses as is.
- P-CSCF Restoration will be performed for all PDN connections, regardless of APN configuration of IMS/non-IMS.
- Upon receiving P-CSCF Restoration trigger for extended mechanism, P-CSCF address discovery priority is first for P-CSCF FQDN. If FQDN is already present in DNS cache, then as per current implementation of HSS based (S5/S8) P-CSCF Restoration, DNS query will not be sent to the DNS server and P-GW will immediately get the DNS response.

Since local DNS cache flush will not be done, operator should configure the cache accordingly.

- In case of S6b RAR, P-GW supports configuration for whether to perform ReAuthentication Request and Response (AAR/AAA) with extended restoration support.
Authentication after RAR for restoration is not mandatory as it increases the authentication signaling flow at AAA Server. In order to maintain backward compatibility with the existing Diameter Relay Agents (DRA)/AAA servers, which expect authentication after RAR, authentication can be configured for RAR with P-CSCF Restoration.
- If the DNS resolution for FQDN fails or P-GW does not have P-CSCF address configured in any other way, P-GW will still send UBR with no P-CSCF address PCO/APCO during restoration.
- If the P-CSCF Restoration is already in progress, then restoration will not be performed again for any second restoration indication received.
- For basic P-CSCF Restoration, call will be cleared with disconnect reason "ue-pcscf-reselect-not-supported (613)".
- P-GW does not expect change in S6b P-CSCF FQDN during ReAuth. In the rare scenario that P-CSCF FQDN is changed in S6b ReAuth, then the new FQDN will be used in next P-CSCF Discovery. If P-CSCF FQDN is changed during ReAuth, then it is not recovered.
- For S6b, every AAR supported-feature will be negotiated. ReAuth AAR will also do the feature renegotiation. It's expected that S6b AAA server should do the renegotiation in every AAA. This is specifically applicable to LTE-WiFi and vice versa handoff. During LTE attachment, supported-feature will not be sent. During WiFi handoff, however, support for P-CSCF Restoration should be indicated in AAR.
- Supported-feature on Gx for P-CSCF Restoration will apply to GGSN/eHRPD calls as well to support handoff scenarios.
- For S6b RAT type WLAN, AAA group supports configuration to control when AAR is sent with the supported-feature to S6b server. If AAA group disables this functionality, then once the AAA response comes with supported-feature it is considered not negotiated. Thus, negotiation depends on the CLI configuration of supported-feature at the time of handling AAA.
- Supported-feature for P-CSCF Restoration in S6b will only go for RAT type WLAN.
- During IPv6 reporting S6b information update, if information update AAA is pending and RAR for restoration is received, then only the restoration will be handled. In this case, ReAuth will not be performed again for extended restoration, even if configured.
- APCO for Update Bearer Request (UBRequest) for extended P-CSCF Restoration in ePDG will be sent at bearer context level itself. APCO is not at message level for UBRequest.

- If S6b RAR ReAuth is pending and AAA of ReAuth is not yet received when RAR for restoration is received, then only the restoration will be handled. In this case, ReAuth will not be performed again for extended restoration, even if configured.
- For PCRF based P-CSCF Restoration/HSS based (S2a/S2b) P-CSCF Restoration, if UE PDN type and the PCO requested P-CSCF address do not match (for example, PDN type is IPv4 and PCO P-CSCF requested in IPv6, and vice versa), then basic restoration will be performed.
- UE Capability PCO and P-CSCF Restoration for S5/S8:

P-CSCF Reselect Support	P-CSCF Address Requested	MME-triggered Restoration	PCRF-triggered Restoration
✓	✓	Extended Restoration	Extended Restoration
✓	✗	Restoration Ignored	Basic Restoration
✗	✓	Basic Restoration	Basic Restoration
✗	✗	Basic Restoration	Basic Restoration

For S2a only, if MCM mode/WPMSI flag and UE P-CSCF re-selection support and P-CSCF address request is received, then only extended P-CSCF Restoration will be performed. For all other scenarios, if P-CSCF Restoration Indication is received, then basic P-CSCF Restoration is performed.

If both MCM/SCM flag are set, then it's considered SCM.

For S2b only, if UE P-CSCF re-selection support and P-CSCF address request is received during establishment or handoff is received, then only extended P-CSCF Restoration will be performed. For all other scenarios, if P-CSCF Restoration Indication is received, then basic P-CSCF Restoration is performed.

Call Flows

PCRF Based P-CSCF Restoration for LTE (S5/S8)

The PCRF-based P-CSCF Restoration makes use of the path through an alternative P-CSCF and PCRF to inform the P-GW regarding P-CSCF Restoration.

There are two mechanisms to handle the P-CSCF Restoration support:

1. **Basic Restoration Support:** UE does not support the P-CSCF Re-selection. P-GW informs UE to release the PDN connection. P-GW initiates bearer deactivation procedure for the default bearer with cause "reactivation requested".
2. **Extended Restoration Support:** P-GW sends the UBR with PCO having list of alternate P-CSCF addresses after the P-CSCF rediscovery. The optional extension avoids the PDN deactivation and re-activation and is based on the P-GW identifying whether or not the UE supports "Update PDP context/bearer at P-CSCF failure". The UE indicates this capability to the P-GW at the activation of the PDN connection in a PCO parameter.

Figure 106: PCRF Based P-CSCF Restoration - EPC

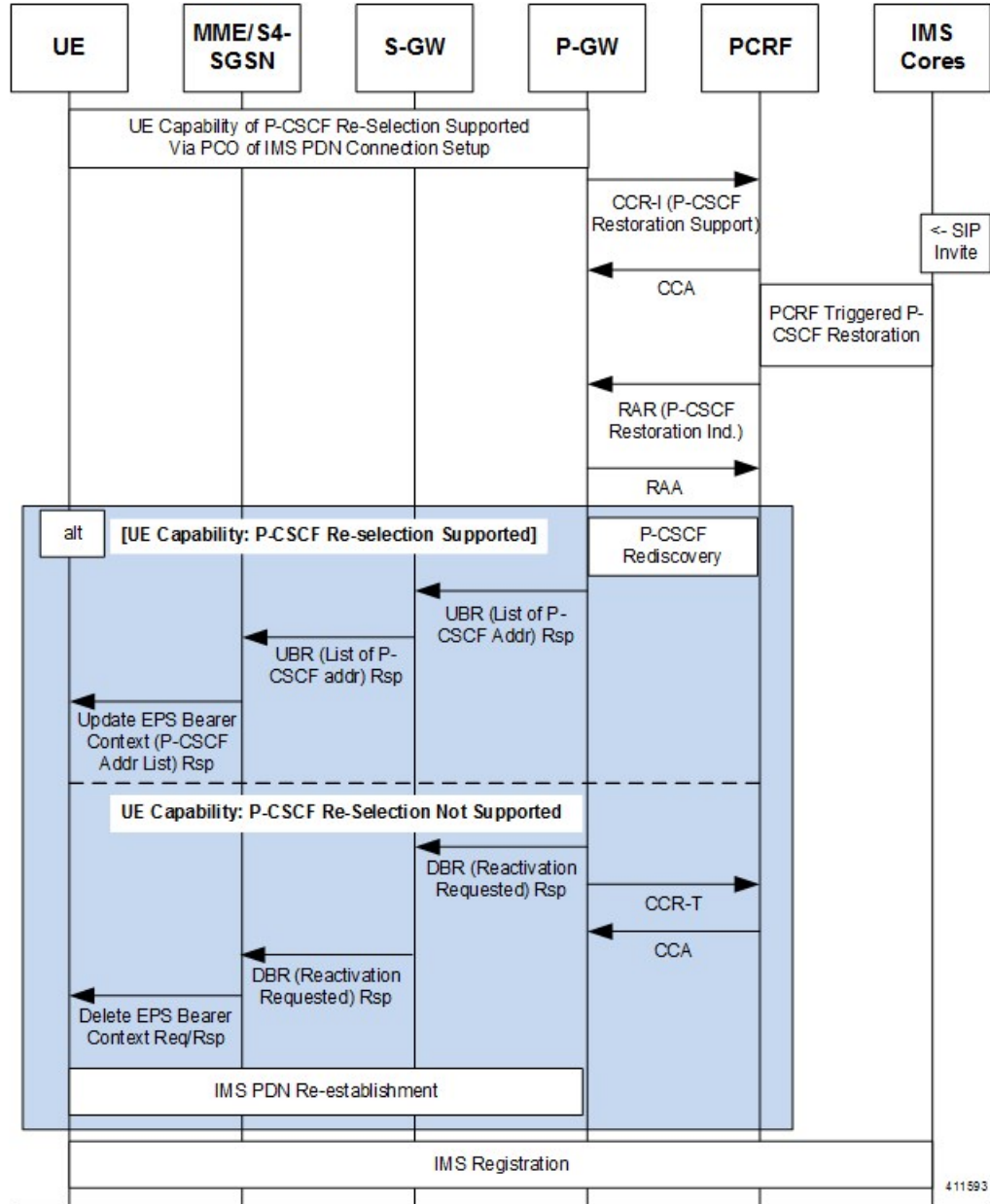

P-CSCF Restoration for WLAN (S2a/S2b)

This section describes solutions to support P-CSCF Restoration for UEs with WLAN access.

There are two mechanisms to handle the P-CSCF Restoration support:

- 1. Basic Restoration Support:** The basic mechanism for the HSS-based solution and for the PCRF-based solution relies on the release of the PDN connection, followed by its re-establishment to trigger a new IMS registration by the UE.

- 2. Extended Restoration Support:** The extension mechanism for trusted WLAN and untrusted WLAN access avoids the release of the PDN connection and triggers a new IMS registration by the UE over the existing PDN connection.

The extension mechanism for trusted WLAN is supported only for multi-connection mode (MCM).

In the basic P-CSCF Restoration for TWAN access or untrusted WLAN access, the P-GW sets the cause "Reactivation requested" when tearing down the PDN connection.

If the re-authorization request is used for the purpose of the P-CSCF Restoration for WLAN, only the P-CSCF Restoration Request bit shall be set in the RAR Flags.

If the P-CSCF Restoration Request bit in the RAR Flags is set in ReAuthorization request (S6b):

- When P-GW triggers the extended P-CSCF restoration mechanism, the P-GW may send the authorization request.
- When P-GW triggers the basic P-CSCF restoration mechanism, the P-GW shall send a Session Termination Request to the 3GPP AAA Server.

For Trusted WLAN Access

- The TWAN shall advertise the support of the WLCP PDN connection modification request procedure over S2a at establishment (or handover) of the PDN connection. This allows the P-GW to use the P-CSCF Restoration extension on this TWAN.
- UE capability (UE support of the P-CSCF Restoration extension for the TWAN access) to the P-GW at the establishment (or handover) of the PDN connection over the WLAN is transferred via PCO IE.
- Upon receipt of a P-CSCF Restoration Indication, the P-GW may invoke this P-CSCF Restoration extension procedure if:
 - The UE is accessing the EPC via a TWAN in the multi-connection mode
 - The UE indicated support of this extension for the TWAN access via PCO, and
 - If the TWAN indicated support of the WLCP PDN connection modification procedure.
 - If UE requested P-CSCF address at establishment or handover.

Otherwise, the basic restoration procedure is executed.

- For a trusted WLAN with the single connection mode or the transparent single connection mode, only the basic P-CSCF Restoration mechanism may apply.
- In the P-CSCF Restoration extension procedure for TWAN access, the P-GW shall send the updated list of the addresses of available P-CSCFs toward the UE via the TWAN using the PCO IE.

Figure 107: PCRF Based P-CSCF Restoration for Trusted WLAN Access

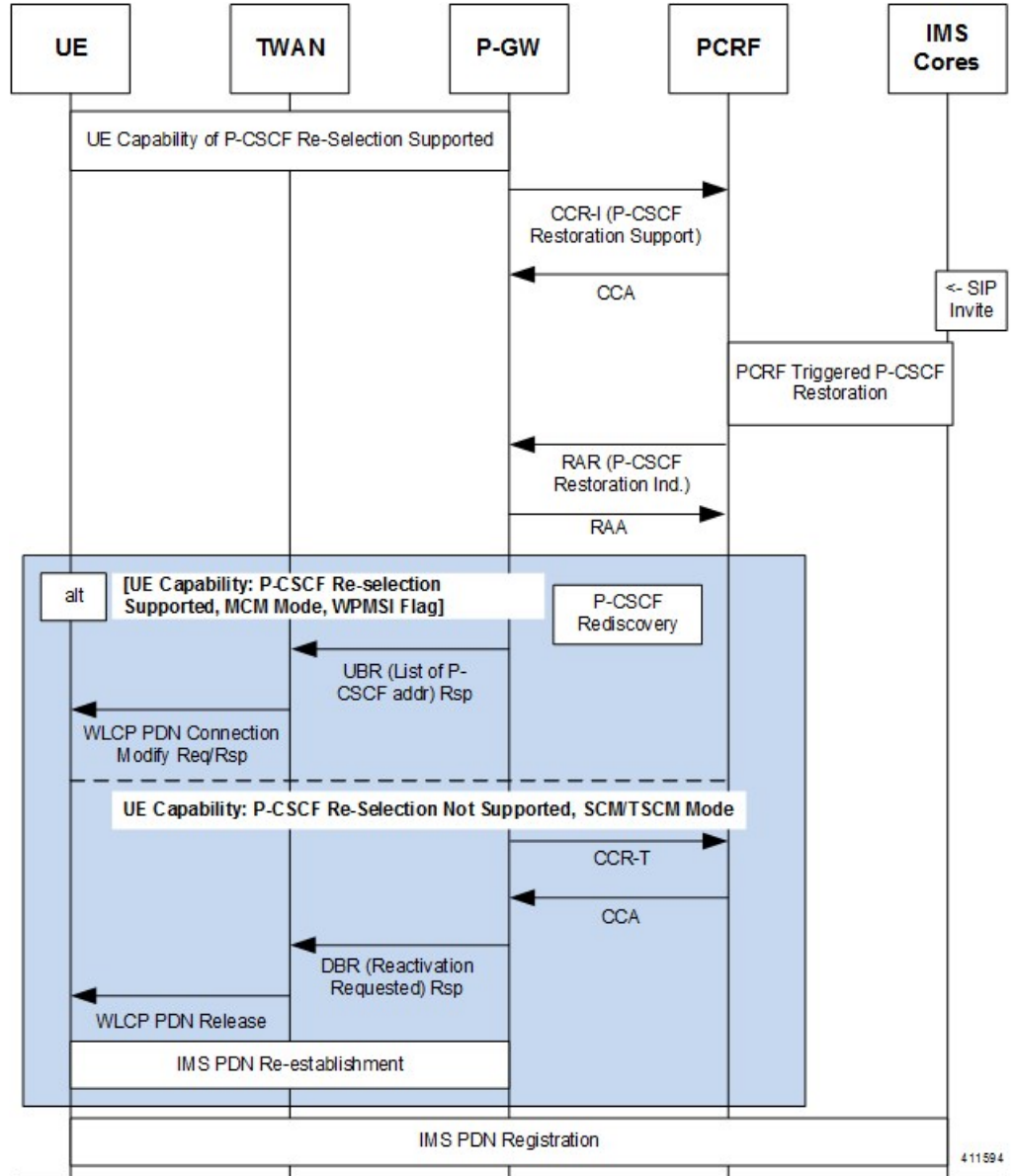
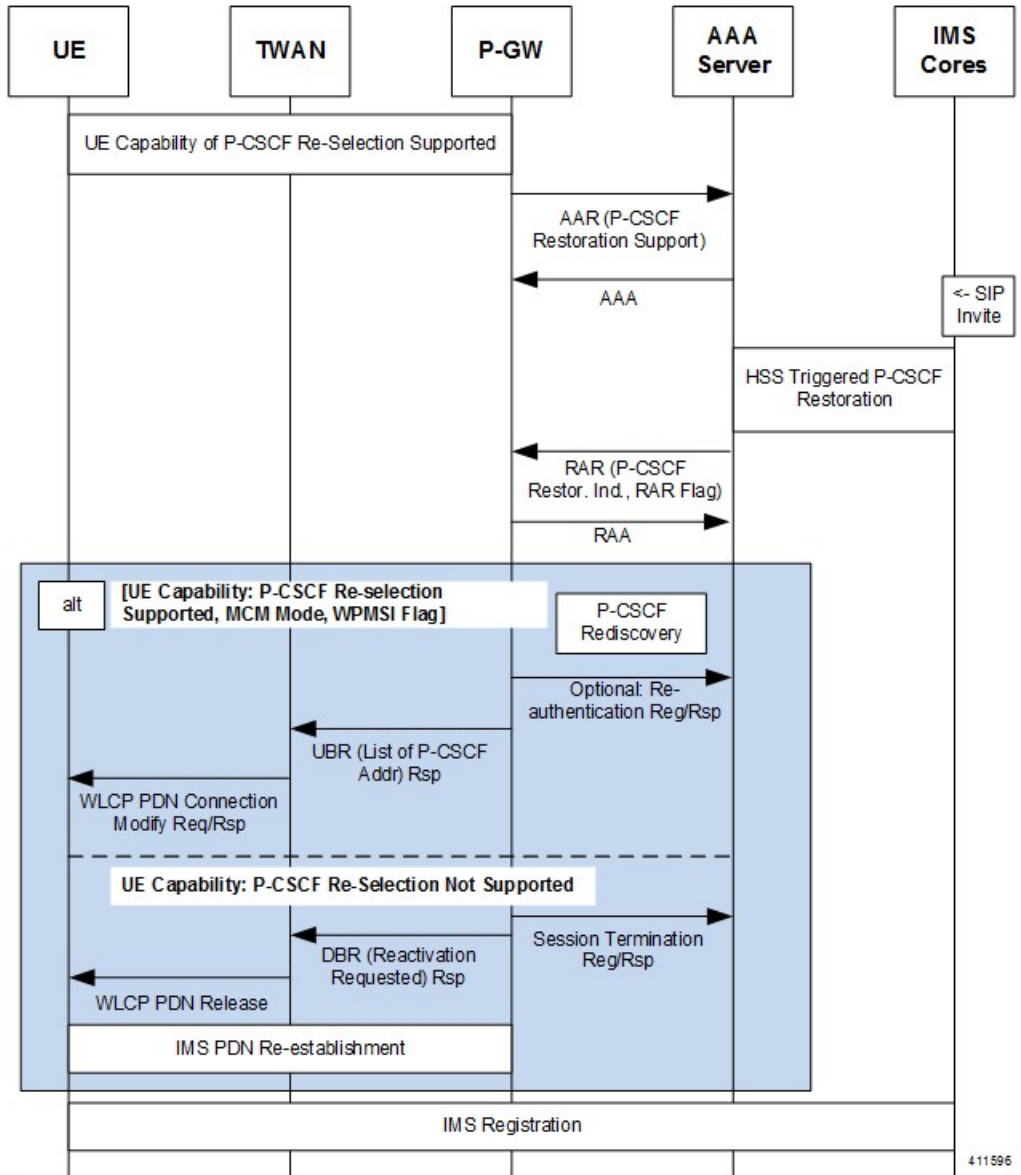

Figure 108: HSS Based P-CSCF Restoration for Trusted WLAN Access



Important Supported feature on S6b is sent in every ReAuth for RAT type WLAN.

For Un-Trusted WLAN Access

An ePDG which supports the P-CSCF Restoration extension for untrusted WLAN shall forward the UE capability (UE support of the P-CSCF restoration extension) in the APCO information element to the P-GW over the S2b interface at the PDN connection establishment (or handover) over S2b.

In the P-CSCF Restoration extension procedure for untrusted WLAN access, the P-GW shall send the updated list of the addresses of available P-CSCFs toward the UE via the ePDG using the APCO IE.

Figure 109: PCRF Based P-CSCF Restoration for Un-Trusted WLAN Access

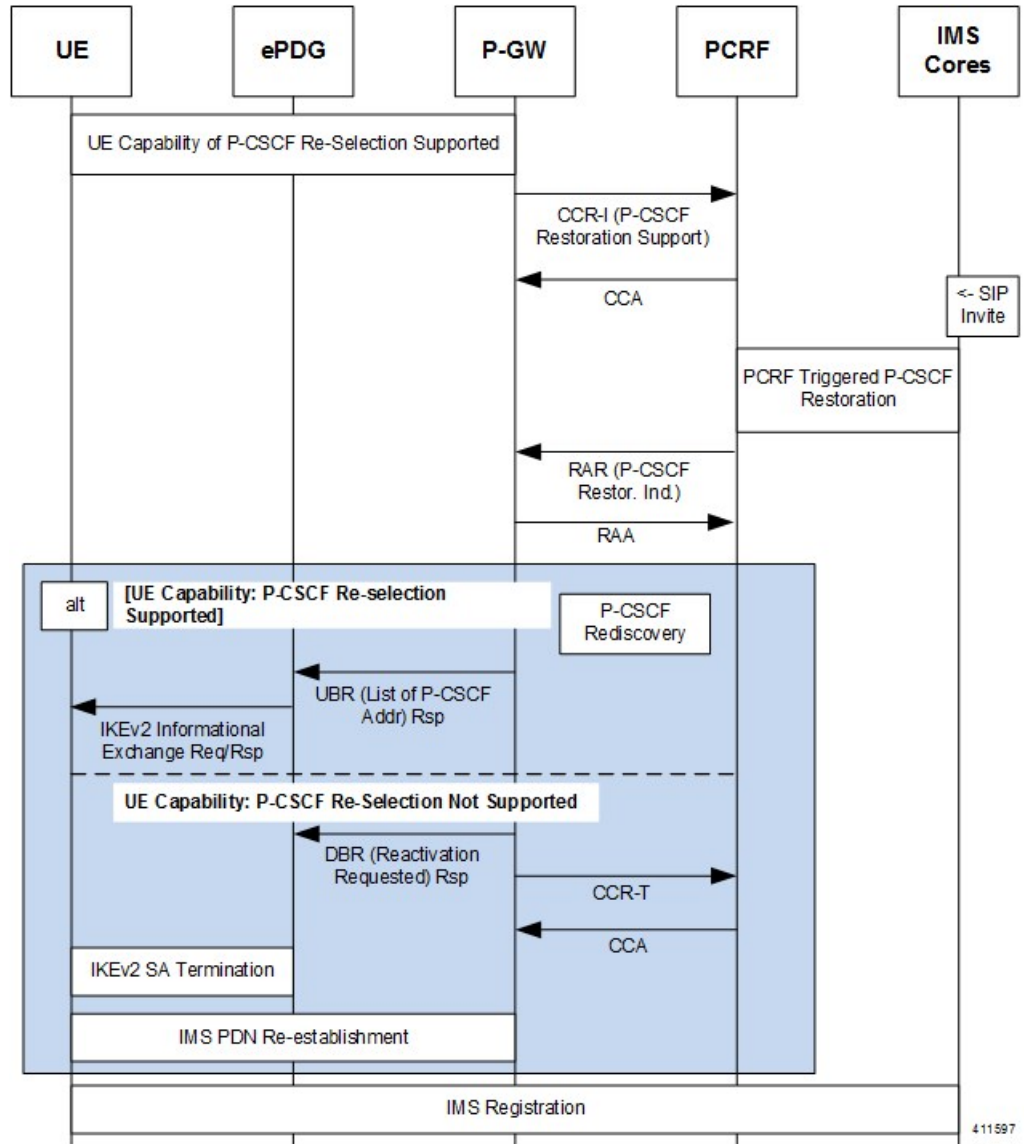
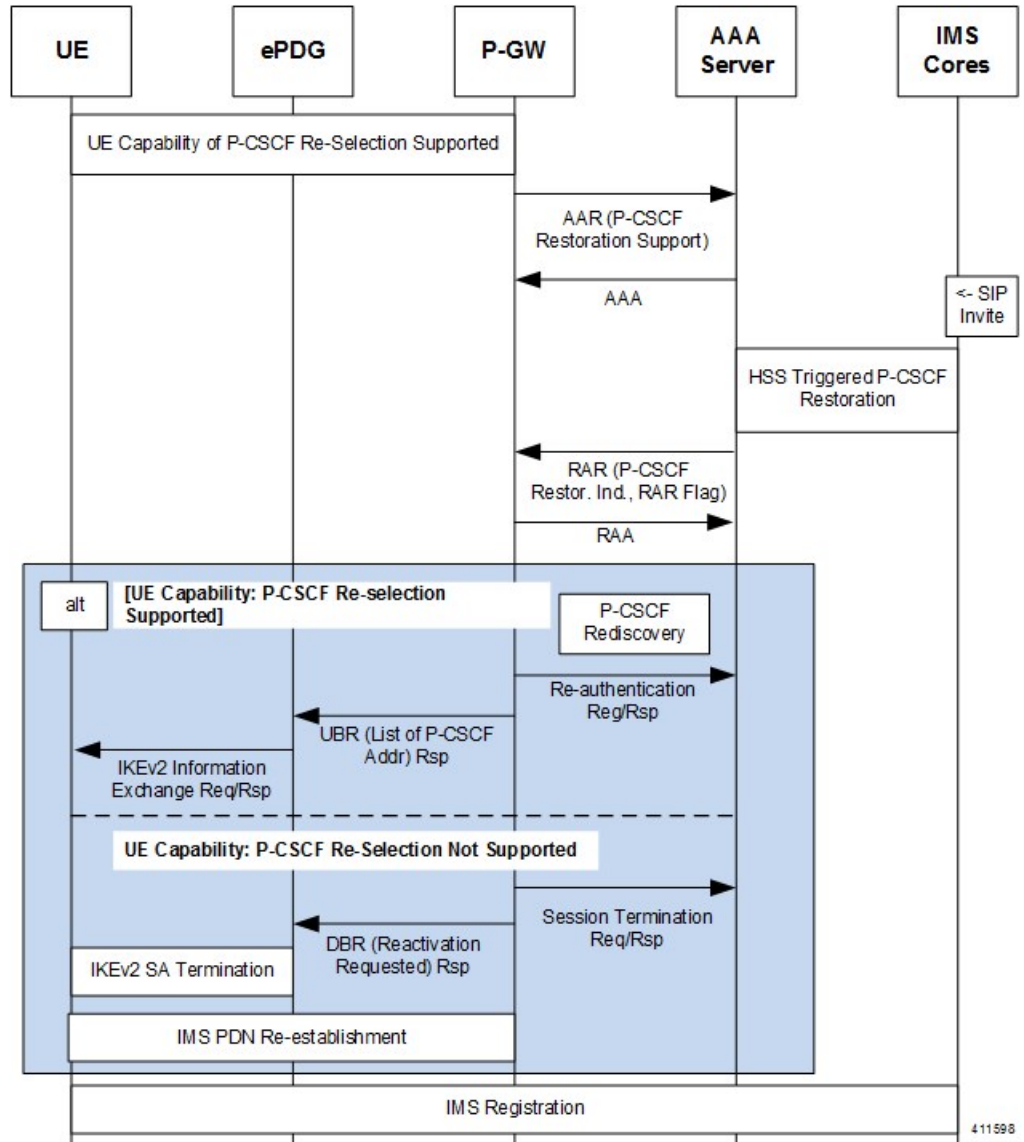

Figure 110: HSS Based P-CSCF Restoration for Un-Trusted WLAN Access



Standards Compliance

- Release 13 3GPP TS 23.380: IMS Restoration Procedures
- Release 13 3GPP TS 24.008: Mobile radio interface Layer 3 specification; Core network protocols
- Release 13 3GPP TS 29.212: Policy and Charging Control (PCC); Reference points
- Release 13 3GPP TS 29.273: 3GPP EPS AAA Interfaces
- Release 13 3GPP TS 29.274: 3GPP Evolved Packet System (EPS); Evolved General Packet Radio Service (GPRS) Tunnelling Protocol for Control plane (GTPv2-C); Stage 3

Configuring the HSS/PCRF-based P-CSCF Restoration

The following section provides the configuration commands to enable support for HSS-based and PCRF-based P-CSCF Restoration feature.

Enabling P-CSCF Restoration Indication on S6b AAA Interface

Use the following configuration commands for encoding Supported-Features AVP in the AAR message to AAA server via S6b interface.

```
configure
  context context_name
    aaa group group_name
      diameter authentication encode-supported-features
pcscf-restoration-indication
end
```

Notes:

- **encode-supported-features**: Encodes Supported-Features AVPs.
- **pcscf-restoration-indication**: Enables the P-CSCF Restoration Indication feature.
- **default encode-supported-features**: Configures the default setting, that is not to send the Supported-Features AVP in AAR message.
- **no encode-supported-features**: Disables the CLI command to not send the Supported-Features AVP.
- **pcscf-restoration-indication** : Keyword is license dependent. For more information, contact your Cisco account representative.

Enabling P-CSCF Restoration Indication on Gx Interface

Use the following configuration for P-CSCF Restoration supported feature.

```
configure
  context context_name
    ims-auth-service service_name
      policy-control
        diameter encode-supported-features pcscf-restoration-ind
end
```

Notes:

- **pcscf-restoration-ind**: Enables the P-CSCF Restoration Indication feature. This keyword is license dependent. For more information, contact your Cisco account representative. By default, this feature is disabled.
- **default encode-supported-features**: The default configuration, which is removing/resetting the supported features.
- **no encode-supported-features**: Removes the previously configured supported features.

Enabling P-CSCF Restoration for Emergency PDNs

Use the following configuration to enable P-CSCF Restoration for Emergency PDNs.

```
configure
context context_name
  pgw-service service_name
    pscf-restoration { hss-solution | custom-hss-solution }
    pscf-restoration emergency-pdn
  end
```

Notes:

- **{ hss-solution | custom-hss-solution }**: Enables standards-based or private extension-based HSS solution for P-CSCF Restoration. This keyword must be configured on a separate command line from **emergency-pdn**.
- **emergency-pdn**: Enables P-CSCF Restoration for Emergency PDNs.
This keyword is license dependent. For more information, contact your Cisco account representative. By default, this feature is disabled.
- **default pscf-restoration**: P-CSCF Restoration is disabled for Emergency PDNs and Private Extn mechanism will be used for P-CSCF Restoration.
- **no pscf-restoration emergency-pdn**: Disables P-CSCF restoration for Emergency PDNs.

Enabling Re-Auth After S6b Triggered P-CSCF Restoration of WLAN

Use the following configuration to enable Re-Auth after S6b triggered P-CSCF Restoration of WLAN.

```
configure
context context_name
  pgw-service service_name
    pscf-restoration s6b-reauth
  end
```

Notes:

- **s6b-reauth**: Enables Re-Auth after S6b triggered P-CSCF Restoration of WLAN. Only applicable for S2a and S2b. By default, Re-Auth will be performed for P-CSCF restoration extension on S6b.
This keyword is license dependent. For more information, contact your Cisco account representative. By default, this feature is disabled.
- **default pscf-restoration**: Re-Auth will be performed for P-CSCF restoration extension on S6b.
- **no pscf-restoration s6b-reauth**: Disables Re-Auth after P-CSCF restoration extension on S6b.

Verifying the HSS/PCRF-based P-CSCF Restoration

show aaa group all

This show command displays **pcscf-restoration-ind** as part of Supported-Features if this feature is configured under AAA group.

```
show aaa group all
  Group name:    default
  Context:      local

  Diameter config:
  Authentication:
  ....
Supported-Features:    pcscf-restoration-ind
  ....
```

show ims-authorization sessions full all

This command generates a display that indicates the negotiation status of this feature.

The following sample display is only a portion of the output which shows **pcscf-restoration-ind** among the Negotiated Supported Features.

```
show ims-authorization sessions full all

  CallId: 00004e22          Service Name:  imsa-Gx
  IMSI: 123456789012341
  ....
  Negotiated Supported Features:
  3gpp-r8
  pcscf-restoration-ind
  ....
```

show pgw-service name <pgw_service>

This command generates a display that indicates the configuration status of this feature.

The following sample display is only a portion of the output.

P-GW service output is enhanced to clearly specify HSS-based solution of **MME-Triggered**; this avoids confusion with the HSS-based S6b Triggered solution. In addition, it displays whether **P-CSCF Restoration supported for Emergency PDNs** and/or **Re-Auth After s6b Triggered P-CSCF Restoration** is enabled.

```
show pgw-service name <pgw_service>

  Service name : pgw_service
  Restoration solution : HSS-based MME-Triggered (Rel12)
  P-CSCF Restoration supported for Emergency PDNs : Yes/No
  Re-Auth After s6b Triggered P-CSCF Restoration : Enabled / Disabled
  ....
```

Monitoring and Troubleshooting the HSS/PCRF-based P-CSCF Restoration

This section provides information regarding show commands and/or their outputs in support of this feature.

The following operations can be performed for troubleshooting any failure related to this feature:

- Verify if the feature is enabled using **show ims-authorization sessions full all** and **show aaa group all** CLI commands. If not enabled, configure the required CLI commands both under Policy Control and AAA group configuration and check if it works.
- Execute **monitor protocol** command and check if the support for P-CSCF Restoration feature is negotiated in CCR-I and AAR messages. If not, enable the respective CLI commands for this feature to work.
- If the failure is still observed, obtain the following information and contact Cisco account representative for further analysis:
 - Monitor protocol log with options 74 (EGTPC) and 75 (App Specific Diameter –Gx/S6b) turned on
 - Logs with sessmgr, imsa, and diameter-auth enabled
 - Output of **show session disconnect reason** CLI command and the relevant statistics at service level

Output of Show Commands

show aaa group all

The **Supported Features** field in this show command output displays whether or not the P-CSCF Restoration feature is configured as part of the Supported-Features AVP.

This supported feature is displayed only when the feature license is configured.

show ims-authorization sessions full all

The **Negotiated Supported Features** field in this show command output displays whether or not the P-CSCF Restoration feature is negotiated with PCRF.

This supported feature is displayed only when the feature license is configured.

show license information

If the license to enable the P-CSCF Restoration feature is configured, then the **show license information** command displays the associated license information.

show pgw-service name <pgw_service>

P-GW service output is enhanced to clearly specify HSS-based solution of **MME-Triggered**; this avoids confusion with the HSS-based S6b Triggered solution. In addition, it displays whether **P-CSCF Restoration supported for Emergency PDNs** and/or **Re-Auth After s6b Triggered P-CSCF Restoration** is enabled.

```
show pgw-service name <pgw_service>
```

```
Service name : pgw_service
Restoration solution : HSS-based MME-Triggered (Rel12)
P-CSCF Restoration supported for Emergency PDNs : Yes/No
Re-Auth After s6b Triggered P-CSCF Restoration : Enabled / Disabled
....
```

show pgw-service statistics all

This command provides statistics on the number of P-CSCF Restorations.

The MME received P-CSCF Restoration count has moved from "**P-CSCF Restoration Indications received:**" to "**MME triggered Restoration**". Now, "**P-CSCF Restoration Indications received:**" shows total number of P-CSCF Restoration indications received (HSS Triggered and PCRF Triggered). Bulkstat counter "**sessstat-pcscf-recovery-count**" will continue to display the MME received P-CSCF Restoration only.

The total number of triggers received on any interface (MME/PCRF/S6b) = Basic + Extended + Ignored (ignored for reasons such as restoration already in progress, license not present, validation check fails, or call not connected).

```
PDNs Released By Reason:
  Network initiated release:          0    MME initiated release:          0
  Admin disconnect:                  0    S4 SGSN initiated release:        0
  GTP-U error ind:                   0
  SGW path failure:                  0
  Local fallback timeout:             0
  UE P-CSCF Reselect not supported:  0
...

S2bGTP-to-eHRPD handover:           eHRPD-to-S2bGTP handover:
  Attempted:                          0    Attempted:                          0
  Succeeded:                           0    Succeeded:                           0
  Failed:                               0    Failed:                              0
...

      P-CSCF Restoration Indications received:      <total_count
at service level>
  HSS Triggered Restoration:
    MME Triggered Restoration:                  <>
    Basic Restoration Performed:                <>
    Extension Restoration Performed:            <>
  S6b Triggered Restoration:
    Basic Restoration Performed:                <>
    Extension Restoration Performed:            <>
  PCRF Triggered Restoration:
    Basic Restoration Performed:                <>
    Extension Restoration Performed:            <>

Data Statistics Per Interface:
...
```

show srp checkpoint statistics active verbose

This command provides the following P-CSCF Restoration micro checkpoint information:

```
.
.
  Total pgw ubr_mbr micro-chkpnt sent:          0
  Total pcscf update micro-chkpnt sent:        0
```

show srp checkpoint statistics standby verbose

This command provides the following P-CSCF Restoration micro checkpoint information:

```
.
.
```

```
PGW ubr_mbr session microchkpt rcvd:          0
PCSCF info update microchkpt rcvd:           0
```

Monitoring Logs

This section provides information on how to monitor the logs that are generated relating to the HSS/PCRF-based P-CSCF Restoration feature.

Gx Diameter Protocol Logs

Under **Supported-Features**, the P-CSCF Restoration **Feature-List** is available in CCR-I/CCA-I section. The output generated will appear similar to the following:

```
<<<<OUTBOUND 13:52:06:117 Eventid:92820(5)
....
[V] [M] Supported-Features:
[M] Vendor-Id: 10415
[V] Feature-List-ID: 1
[V] Feature-List: 16777217
....
INBOUND>>>> 13:52:06:118 Eventid:92821(5)
....
[V] [M] Supported-Features:
[M] Vendor-Id: 10415
[V] Feature-List-ID: 1
[V] Feature-List: 16777216
....
```

The **PCSCF-Restoration-Indication** AVP is available in RAR. The output generated will appear similar to the following:

```
INBOUND>>>> 13:52:26:119 Eventid:92821(5)
....
[M] Re-Auth-Request-Type: AUTHORIZE_ONLY (0)
[V] PCSCF-Restoration-Indication: 0
....
```

S6b Diameter Protocol Logs

The **Supported-Features** field is available in AAR/AAA section. The log output generated will appear similar to the following:

```
<<<<OUTBOUND 15:37:23:561 Eventid:92870(5)
....
[V] [M] Supported-Features:
[M] Vendor-Id: 10415
[V] Feature-List-ID: 1
[V] Feature-List: 1
....
INBOUND>>>> 15:37:23:562 Eventid:92871(5)
....
[V] [M] Supported-Features:
[M] Vendor-Id: 10415
[V] Feature-List-ID: 1
[V] Feature-List: 1
....
```

The **RAR-Flags** field is available in RAR section. The log output generated will appear similar to the following:

```
INBOUND>>>>> 15:37:43:562 Eventid:92871(5)
.....
[M] Re-Auth-Request-Type: AUTHORIZE_ONLY (0)
[V] RAR-Flags: 2
.....
```

Bulk Statistics

P-GW Schema

The following counters are specific to **pcscf-recovery**:

- sssstat-pcscf-recovery-count
- sssstat-pcscf-recovery-basic-count
- sssstat-pcscf-recovery-extension-count
- sssstat-s6b-pcscf-recovery-count
- sssstat-s6b-pcscf-recovery-basic-count
- sssstat-s6b-pcscf-recovery-extension-count
- sssstat-pcrf-pcscf-recovery-count
- sssstat-pcrf-pcscf-recovery-basic-count
- sssstat-pcrf-pcscf-recovery-extension-count

SAEGW Schema

The following counters are specific to **pcscf-recovery**:

- pgw-sssstat-pcscf-recovery-count
- pgw-sssstat-pcscf-recovery-basic-count
- pgw-sssstat-pcscf-recovery-extension-count
- pgw-sssstat-s6b-pcscf-recovery-count
- pgw-sssstat-s6b-pcscf-recovery-basic-count
- pgw-sssstat-s6b-pcscf-recovery-extension-count
- pgw-sssstat-pcrf-pcscf-recovery-count
- pgw-sssstat-pcrf-pcscf-recovery-basic-count
- pgw-sssstat-pcrf-pcscf-recovery-extension-count



CHAPTER 28

ICAP Interface Support

This chapter provides information on configuring the external Active Content Filtering servers for a core network service subscriber. This chapter also describes the configuration and commands that are used to implement this feature.

It is recommended that you select the configuration example that best meets your service model, and configure the required elements for that model, as described in respective product Administration Guide, before using the procedures in this chapter.

The following products currently support ICAP interface functionality:

- GGSN
- P-GW
- [ICAP Interface Support Overview, on page 697](#)
- [Configuring ICAP Interface Support, on page 702](#)

ICAP Interface Support Overview

This feature supports streamlined ICAP interface to leverage Deep Packet Inspection (DPI) to enable external application servers to provide their services without performing DPI, and without being inserted in the data flow. For example with an external Active Content Filtering (ACF) Platform.

A high-level view of the streamlined ICAP interface support for external ACF is shown in the following figure:

Figure 111: High-Level View of Streamlined ICAP Interface with external ACF

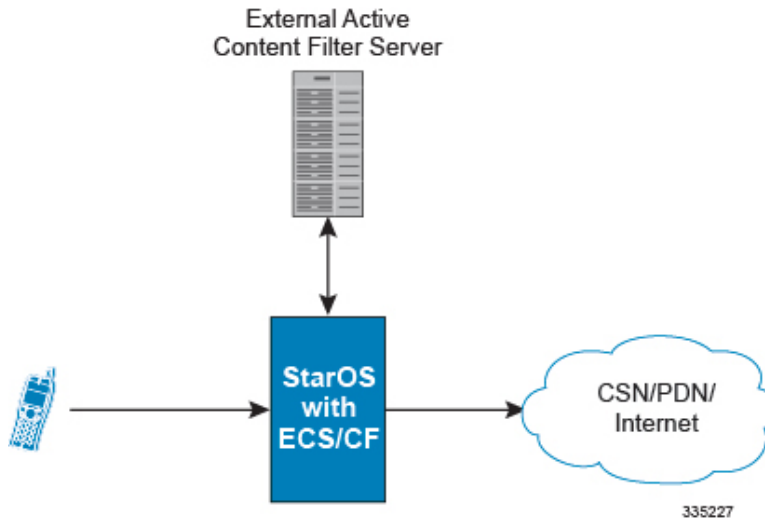

The system with ECS is configured to support DPI and the system uses this capability for content charging as well. WAP and HTTP traffic is content filtered over the ICAP interface. RTSP traffic that contains adult content can also be content filtered on the ICAP interface. Only the RTSP Request packets will be considered for content filtering over the ICAP interface.

If a subscriber initiates a WAP (WAP1.x or WAP2.0) or Web session, the subsequent GET/POST request is detected by the DPI function. The URL of the GET/POST request is extracted and passed, along with subscriber identification information and the subscriber request, in an ICAP message to the application server. The application server checks the URL on the basis of its category and other classifications like, type, access level, content category and decides if the request should be authorized, blocked, or redirected by answering to the GET/POST with:

- A 200 OK message if the request is accepted.
- A 302 Redirect message in case of redirection. This redirect message includes the URL to which the subscriber must be redirected.
- Deny-response code 200 for RTSP requests is not supported. Only 403 "Forbidden" deny-response code will be supported.

Depending on the response received, the system with ECS will either pass the request unmodified, or discard the message and respond to the subscriber with the appropriate redirection or block message.

Content charging is performed by the Active Charging Service (ACS) only after the request has been controlled by the application server. This guarantees the appropriate interworking between the external application and content-based billing. In particular, this guarantees that charging will be applied to the appropriate request in case of redirection, and that potential charging-based redirections (i.e. Advice of Charge, Top Up page, etc.) will not interfere with the decisions taken by the application server.

Functions of the ACF include:

- Retrieval of subscriber policies based on the subscriber identity passed in the ICAP message
- Determining the appropriate action (permit, deny, redirect) to take for the type of content based on subscriber profile
- Communication of the action (permit, deny, or redirect) decision for the URL back to the ACS module

Supported Networks and Platforms

This feature supports the Cisco ASR 5500 platform for the core network services configured on the system.

For additional platform information, refer to the appropriate *System Administration Guide* and/or contact your Cisco account representative.

License Requirements

External Content Filtering Server support through Internet Content Adaptation Protocol (ICAP) interface is a licensed Cisco feature. A separate feature license may be required. Contact your Cisco account representative for detailed information on specific licensing requirements.

For information on installing and verifying licenses, refer to the *Managing License Keys* section of the *Software Management Operations* chapter in the *System Administration Guide*.

Failure Action on Retransmitted Packets

ICAP rating is enabled for retransmitted packet when default ICAP failure action was taken on an ICAP request for that flow. ICAP default failure action is taken on the pending ICAP request for a connection when the connection needs to be reset and there is no other redundant connection available. For example, in the ICAP request timeout and ICAP connection timeout scenarios. In these cases the retransmitted packet in the uplink direction is sent for ICAP rating again.

In case of WAP CO, uplink retransmitted packet for the WAP transactions for which ICAP failure action was taken will be sent for ICAP rating. WSP header of the retransmitted packet is not parsed by the WSP analyzer. The URL received in the previous packet for that transaction is used for ICAP rating. If failure action was taken on multiple WTP transactions for the same flow (case: WTP concatenated GET request) then uplink retransmitted packet for each of the transaction is sent for rating again.

In case of HTTP, uplink retransmitted packets for the HTTP flow on which ICAP failure action is taken is sent for ICAP rating. The URL present in the current secondary session (last uplink request) is used for ICAP rating. However, if there were multiple outstanding ICAP request for the same flow (pipelined request) then for the retransmitted packet the URL that will be sent for rating will be that of the last GET request.

Retransmission in various cases of failure-action taken on re-transmitted packets when the ICAP response is not received for the original request and the retransmitted request comes in:

- WSP CO:
 - Permit: The uplink packet is sent for ICAP rating and depending on the ICAP response the WTP transaction is allowed/blocked. It is possible that the WAP gateway sends the response for the permitted GET request. Hence, there is a race condition and the subscriber may be able to view the web page even though the rating was redirect or content insert.
 - Content Insert: The retransmitted packet is not sent for ICAP rating.
 - Redirect: The retransmitted packet is not sent for ICAP rating.
 - Discard: The uplink packet is sent for ICAP rating and depending on the ICAP response the WTP transaction is allowed/blocked.
 - Terminate flow: The uplink packet is sent for ICAP rating and depending on the ICAP response the WTP transaction is allowed or blocked. The WAP gateway may send an Abort transaction for this

GET request if the WSP disconnect packet sent while terminating the flow is received by the WAP gateway.

- HTTP:
 - Permit: The uplink packet is sent for ICAP rating and depending on the ICAP response the last HTTP GET request. It is possible that the HTTP server sends the response for the permitted GET request. Hence there is a race condition and the subscriber may be able to view the web page even though the rating was redirect or content insert.
 - Content Insert: Retransmitted packets are dropped and not charged.
 - Redirect: Retransmitted packets are dropped and not charged.
 - Discard: The uplink packet is sent for ICAP rating and depending on the ICAP response the WTP transaction allowed/blocked.
 - Terminate flow: Retransmitted packets are dropped and not charged.

- RTSP:

The following scenarios describe the failure actions where an RTSP request is received from the client. If ICAP is enabled, then the request goes to the ICAP server for content filtering.

- Allow: If the failure action configured is "allow", the RTSP request packet is sent out after applying the appropriate disposition action. Here, the flow remains the same as in the case if the ICAP response received is 200 OK.
- Content Insert: If the failure action configured is "content-insertion <string of size 1 to 128>", then this failure action for RTSP request will not be supported. Instead the failure action "Discard" for such an RTSP request will be supported.
- Redirect-URL: If the failure action configured is "redirect-url <string of size 1 to 128>", then a TCP FIN_ACK packet with an RTSP "302 Moved Temporarily" response header is inserted towards the client containing the said URL for redirection. A TCP RST packet is inserted towards the server. The underlying TCP connection is thus closed. If the RTSP client wants to retry to the redirected URL, the opening of a new TCP connection must be initiated.
- Discard: If the failure action configured is "discard", then the RTSP request packet received from the client is quietly discarded and no notification is sent to the client.
- Terminate flow: If the failure action configured is "terminate-flow", then the TCP connection is torn down by injecting a TCP FIN-ACK towards the client and a RST packet towards the server. However, no notification will be sent to the RTSP client and the server regarding this flow termination.

ICAP Client Communication with RFC 3507 compliance

The ICAP Content Filtering solution is extended to support ICAP client communication with ICAP server on Cisco ASR 5500 P-GW and HA in compliance with RFC 3507 - Internet Content Adaptation Protocol (ICAP). Only HTTP Request modification and partial enhancement of error codes per RFC 3507 is addressed in this release. The ICAP client running on P-GW/HA communicates with external ICAP server over ICAP protocol. If content filtering is enabled for a subscriber, all HTTP GET requests from that subscriber are validated by

the content filtering server (ICAP server), and is allowed, denied or redirected depending on the content categorization request.

Content-Filtering can be enabled for subscribers either through Override Control (OC) feature for predefined and static rules, or L7 Dynamic Rule Activation feature. A configurable option is added in the Content Filtering Server Group Configuration Mode to configure ICAP header that includes two parameters - Subscriber number information and CIPA (Children's Internet Protection Act) category.



Important Override Control and L7 Dynamic Rule Activation are license-controlled features. A valid feature license must be installed prior to configuring these features. Contact your Cisco account representative for more information.

- Subscriber Number: The "Subscription ID" AVP is sent from gateway to PCRF in CCR message. The AVP values are received to the gateway from HSS. The gateway does not receive this AVP in CCI-A message.
- CIPA category: The category string will be provided by PCRF and is included as an extension header in ICAP request modification message. The AVP will be received from PCRF in CCA-I or RAR.

Dictionary and AVP Support

A new Content Filtering (CF) dictionary "custom4" is introduced and the following new AVPs are added to r8-gx-standard and custom4 dictionaries.

- Override-Content-Filtering-State: This attribute carries information about Content Filtering status (CF state) of rules or charging-action. This AVP is used for overriding the content-filtering status of static and predefined rules. This attribute is included in the Override-Control grouped AVP.
- CIPA: This attribute contains the Children's Internet Protection Act (CIPA) category string value that is treated as an ICAP plan identifier. This identifier helps ICAP server in locating the correct Content Filtering plan i.e. CIPA category based on which the packet is processed.

This attribute value is received from PCRF over Gx interface and is included in ICAP header while sending ICAP request.

- L7-Content-Filtering-State: This attribute carries information about Content Filtering status (CF state) of L7 rules. This attribute indicates whether or not the ICAP functionality is enabled or disabled for L7 charging rule definition received for installation from PCRF. Based on this attribute value, the traffic matching to the dynamic rule is sent to ICAP server.

This attribute is included in the L7-Application-Description grouped AVP for L7 rule processing. This is applicable only for HTTP protocol.



Important CIPA and flags for controlling content filtering via OC and L7 Dynamic Rules features is applicable only for r8-gx-standard dictionary.

In addition to the new AVP support, L7-Field AVP in the L7-Application-Description grouped AVP is encoded to additionally accept ANY-MATCH as the input. The current framework does not support the existing field "vlan-id" in Override-Control, which is present in charging action. Hence, the Override-Content-Filtering-State AVP replaces Override-VLAN-ID to support OC.

When subscriber initiates create session request, P-GW/HA sends CCR-I message to PCRF to obtain subscriber profile. PCRF responds with CCA-I message that contains CIPA and OC information if ICAP functionality is enabled for this subscriber.

In the case of L7 dynamic rules, the Content-Filtering capability is enabled by sending L7-Content-Filtering-State AVP in L7-Application-Description grouped AVP. At least one L7 filter should be present when L7-Content-Filtering-State is received for the dynamic rule. If L7-Content-Filtering-state AVP is sent along with L7 filter information AVP, then the Content-Filtering state will not be considered. Hence, the filter received with L7-Content-Filtering-State will not be processed and the L7 rule will be discarded.

In the case of Override Control, when content filtering is enabled for subscriber, PCRF sends ICAP flag through Override-Control AVP. This AVP overwrites charging action to enable ICAP feature for that subscriber.

Refer to the *AAA Interface Administration and Reference* for more information on the supported AVPs.

Limitations

The limitations for this feature are listed below:

- Only IPv4 addressing scheme is supported.
- ICAP content filtering is applicable only for HTTP traffic. HTTPS traffic is not supported by ICAP client.
- Accelerated path will not be supported for this feature.

Configuring ICAP Interface Support

This section describes how to configure the Content Filtering Server Group (CFSG) through Internet Content Adaptation Protocol (ICAP) interface between ICAP client and ACF server (ICAP server).



Important This section provides the minimum instruction set for configuring external content filtering servers on ICAP interface on the system. For more information on commands that configure additional parameters and options, refer to *CFSG Configuration Mode Commands* chapter in *Command Line Interface Reference*.

To configure the system to provide ICAP interface support for external content filtering servers:

-
- Step 1** Create the Content Filtering Server Group and create ICAP interface with origin (local) IP address of chassis by applying the example configuration in [Creating ICAP Server Group and Address Binding, on page 703](#).
 - Step 2** Specify the active content filtering server (ICAP server) IP addresses and configure other parameters for ICAP server group by applying the example configuration in [Configuring ICAP Server and Other Parameters, on page 703](#).
 - Step 3** Configure the content filtering mode to external content filtering server group mode in ECS rule base by applying the example configuration in [Configuring ECS Rulebase for ICAP Server Group, on page 704](#).
 - Step 4** Configure the charging action to forward HTTP/RTSP/WAP GET request to external content filtering servers on ICAP interface in Active Charging Configuration mode by applying the example configuration in [Configuring Charging Action for ICAP Server Group, on page 704](#).
 - Step 5** Verify your ICAP interface and external content filtering server group configuration by following the steps in [Verifying the ICAP Server Group Configuration, on page 705](#).

- Step 6** Save your configuration to flash memory, an external memory device, and/or a network location using the Exec mode command **save configuration**. For additional information on how to verify and save configuration files, refer to the *System Administration Guide* and the *Command Line Interface Reference*.

Creating ICAP Server Group and Address Binding

Use the following example to create the ICAP server group and bind the IP addresses:

```
configure
  context <icap_ctxt_name> [ -noconfirm ]
    content-filtering server-group <icap_svr_grp_name> [ -noconfirm ]
      origin address <ip_address>
    end
```

Notes:

- <ip_address> is local IP address of the CFSG endpoint.

Configuring ICAP Server and Other Parameters

Use the following example to configure the active content filtering (ICAP server) and other related parameters:

```
configure
  context <icap_context_name>
    content-filtering server-group <icap_server_grp_name>
      icap server <ip_address> [ port <port_number> ] [ max <max_msgs> ] [
priority <priority> ] [ standby ]
      connection retry-timeout <retry_timeout>
      deny-message <msg_string>
      dictionary { custom1 | custom2 | custom3 | custom4 | standard }
      failure-action { allow | content-insertion <content_string> | discard
| redirect-url <url> | terminate-flow }
      header extension options { cipa-category cipa_category_name |
subscriber-number subscriber_num_name } +
      response-timeout <timeout>
    end
```

Notes:

- Only one ICAP Server can be configured per Content Filtering Server Group.
- The **standby** keyword can be used to configure the ICAP server as standby. A maximum of ten active and standby ICAP servers per Content Filtering Server Group can be configured. The active and standby servers under the same server group can be configured to work in active-standby mode.
- The maximum outstanding request per ICAP connection configured using the optional **max** <max_msgs> keyword is limited to one. Therefore, any other value configured using the **max** keyword will be ignored.
- *Optional.* To configure the ICAP URL extraction behavior, in the Content Filtering Server Group configuration mode, enter the following command:

```
url-extraction { after-parsing | raw }
```

By default, percent-encoded hex characters in URLs sent from the ACF client to the ICAP server will be converted to corresponding ASCII characters and sent.

- The **custom4** dictionary is a custom-defined dictionary that specifies user-defined information in the ICAP request message. The ICAP request message includes subscriber number and CIPA category values.

When **custom4** dictionary is configured, ICAP requests are formed as part of ICAP RFC 3507 request mode request. If any other dictionary is configured, the earlier implementation of ICAP client will not be partial RFC compliant.

- The **header extension options** command configures ICAP header parameters - subscriber number and CIPA category.

Configuring ECS Rulebase for ICAP Server Group

Use the following example to configure the content filtering mode to ICAP server mode in the ECS rulebase for content filtering:

```
configure
  require active-charging
  active-charging service <acs_svc_name> [ -noconfirm ]
    rulebase <rulebase_name> [ -noconfirm ]
      content-filtering mode server-group <cf_server_group>
    end
end
```

Notes:

- The **optimized-mode** keyword is not available.



Important After you configure **configure**, **require active-charging**, **active-charging service <acs_svc_name> [-noconfirm]**, and **rulebase** CLI commands, you must save the configuration and then reload the chassis for the command to take effect. For information on saving the configuration file and reloading the chassis, refer to the *System Administration Guide* for your deployment.

Configuring Charging Action for ICAP Server Group

Use the following example to configure the charging action to forward HTTP/WAP GET request to ICAP server for content processing.

```
configure
  active-charging service <acs_svc_name>
    charging-action <charging_action_name> [ -noconfirm ]
      [ no ] content-filtering processing server-group
    end
end
```

Notes:

- If the content-filtering flag supplied by charging action is required to configure the Override Control feature, then the **no content-filtering processing** command must be configured. This will ensure overriding content-filtering processing to be enabled or disabled through the Override Control feature.

Verifying the ICAP Server Group Configuration

This section explains how to display and review the configurations after saving them in a .cfg file and also to retrieve errors and warnings within an active configuration for a service.



Important All commands listed here are under Exec mode. Not all commands are available on all platforms.

These instructions are used to verify the configuration for this feature.

Step 1 Verify your ICAP Content Filtering Server Group configuration by entering the following command in Exec Mode:

show content-filtering server-group

The following is a sample output. In this example, an ICAP Content Filtering server group named *icap_cfsg1* was configured.

```
Content Filtering Group:      icap_cfsg1
Context:                     icap1
Origin Address:              1.2.3.4
ICAP Address (Port):         1.2.3.4(1344)
Max Outstanding:             256
Priority:                     1
Response Timeout: 30 (secs)  Connection Retry Timeout: 30 (secs)
Dictionary:                  standard
Timeout Action:              terminate-flow
Deny Message:               "Service Not Subscribed"
URL-extraction:              after-parsing
Header Extension Options:    subscriber-number i-sub
Content Filtering Group Connections: NONE
Total content filtering groups matching specified criteria: 1
```

Step 2 Verify any configuration error in your configuration by entering the following command in Exec Mode:

show configuration errors



CHAPTER 29

Increase in Monitoring of Peers Supported Through Heartbeat Mechanism for PMIP Sessions

This chapter describes the following topics:

- [Feature Summary and Revision History, on page 707](#)
- [Feature Description, on page 708](#)
- [Configuring the Increase in Number of PMIP Sessions Supported with the Heartbeat Mechanism Feature, on page 709](#)
- [Monitoring and Troubleshooting, on page 710](#)

Feature Summary and Revision History

Summary Data

Applicable Product(s) or Functional Area	<ul style="list-style-type: none">• P-GW• SAEGW
Applicable Platform(s)	<ul style="list-style-type: none">• ASR 5500• VPC - SI• VPC - DI
Feature Default	Disabled - Configuration Required
Related Changes in This Release	Not Applicable
Related Documentation	<ul style="list-style-type: none">• <i>Command Line Interface Reference</i>• <i>P-GW Administration Guide</i>• <i>SAEGW Administration Guide</i>

Revision History

Revision Details	Release
First introduced.	21.4

Feature Description

In the existing setup, the HA Manager supports monitoring of Proxy Mobile IPv6 (PMIP) sessions for up to 256 peers through the heartbeat mechanism. Now there is a requirement to increase the monitoring of peers from 256 to 128000.

To increase the number of PMIP sessions to enable more peers to be monitored for path failure with the heartbeat mechanism, a new CLI **monitor-max-peers** is added under the LMA Service Configuration mode. This feature supports the following behavior:

- When configured, the maximum number of peers that can be supported for heartbeat monitoring can be increased from 256 to 128000 peers.
- The first 128000 peers are identified during the calls irrespective of whether the heartbeat mechanism is enabled or not.
- A separate list is maintained for retransmission heartbeats and periodic heartbeats for batch processing.
- The decision to monitor peers is done at the time of call setup, recovery, and ICSR. For example, consider that there are more than 256 peers (considering the CLI is configured for a maximum of 128000 peers) that are being monitored for heartbeat. Later, this configuration is changed to default, which is for a maximum of only 256 peers. Then, monitoring continues for all peers until HA Manager recovery or ICSR (with monitor-max-peers configuration of a maximum 256 peers) occurs.
- The parameters for batch processing for heartbeat messages are changed as follows:

	Batch Size (before)	Batch Size	Batch Interval (before)	Batch Interval
Periodic heartbeat batch	100	550	200 ms	200 ms
Retransmission heartbeat batch	100	550	200 ms	100 ms

- If more than 10% of peers (12800 peers) are not responding, then the detection of path failure of nodes is delayed. This delay is to avoid a huge impact on performance when such a condition occurs.

If retransmissions start occurring for more than the batch size expected based on the calculations, then the heartbeat messages follow the periodic timer for sending heartbeat messages. For example, if the configuration of the heartbeat interval is 60 seconds, retransmission timeout is 3 seconds, and maximum retries is 3.

Now if the number of heartbeat messages for retransmissions exceed the expected batch size, then instead of a retransmission occurring every 3 seconds, retransmissions of heartbeat messages start with interval of 60 seconds. Therefore, under normal condition if a peer path failure was detected at a maximum of 9 seconds (3*3), it is now detected at 180 seconds (60*3).

- Minimum heartbeat interval must be 60 seconds.

If 128000 peers are configured for monitoring heartbeat, then heartbeat interval must not be configured for less than 60 seconds. If the heartbeat interval is configured for less than 60 seconds, then a configuration error is displayed.

- Minimum heartbeat retransmission timeout should be three seconds.

If 128000 peers are configured for monitoring heartbeat, then heartbeat retransmission timeout must not be configured for less than three seconds. If the heartbeat interval is configured for less than 60 seconds, then a configuration error is displayed.

- The CLI is configured at the service level but the list is maintained at the instance level. Therefore, it is recommended that all services have the same configuration.

If services have different configuration, then the limitation is based on that service level configuration. However, the maximum number of peers is determined based on how many peers are already there in that instance.

For example, consider two services: lma1 and lma2. lma1 has the monitor-max-peers configured as 128000 peers. lma2 has monitor-max-peers configured as 256 peers. Now if the call comes from lma1, it checks the max peers limitation of 128000 peers. If the call comes from lma2, it checks max peers limitations of 256. However, for lma2 it may include all 256 peers that are being monitored in lma1.



Note This feature is customer-specific. For more information, contact your Cisco account representative.

Configuring the Increase in Number of PMIP Sessions Supported with the Heartbeat Mechanism Feature

The following section provides the configuration commands to enable or disable the feature.

heartbeat monitor-max-peers

This new CLI command supports monitoring of a maximum of 128000 PMIP sessions through the heartbeat mechanism. This CLI is added under the LMA Service Configuration mode.

To configure monitoring of a maximum number of PMIP sessions, enter the following commands:

```
context context_name
configure lma-service service_name
[ default ] heartbeat monitor-max-peers
end
```

Notes

- **default:** Monitors 256 peers through the heartbeat mechanism. This CLI is disabled by default.
- **heartbeat monitor-max-peers:** Monitors a maximum of 128000 peers through the heartbeat mechanism.

Monitoring and Troubleshooting

This section provides information regarding show commands and/or their outputs in support of this feature.

Show Commands and/or Outputs

The output of the following CLI command has been enhanced in support of the feature.

show lma-service all

The following **show lma-service all** CLI command now includes the configured heartbeat monitor max peers value.

On configuring the new CLI – heartbeat monitor-max-peers:

```
show lma-service all
Heartbeat Support:      Enabled
Heartbeat Interval:    60
Heartbeat Retransmission timeout: 1
Heartbeat Max Retransmissions: 1
Heartbeat Monitor Max Peers: 128000
```

On configuring the default CLI – default heartbeat monitor-max-peers

```
show lma-service all
Heartbeat Support:      Enabled
Heartbeat Interval:    60
Heartbeat Retransmission timeout: 1
Heartbeat Max Retransmissions: 1
Heartbeat Monitor Max Peers: 256
```

Restrictions:

- A maximum of 128000 PMIP sessions can be monitored with the new CLI.
- The following CLI restrictions are added for configuring **heartbeat monitor-max-peers** CLI command.

At service startup time (boxer configuration boot):

If heartbeat interval is less than 60 seconds (for the lma-service) or retransmission timeout is less than 3 seconds (across lma-services) then the monitor-max-peers command displays a configuration error and the monitor-max-peers configuration is not applied and vice-versa.

At the time of updating the Service configuration:

- While configuring the heartbeat interval of less than 60 seconds if the monitor-max-peers is already configured in that lma-service or across lma-services then it displays a configuration error.
- While configuring a heartbeat retransmission timeout of less than 3 seconds if the monitor-max-peers is already configured in that lma-service or across lma-services then it displays a configuration error.
- While configuring monitor-max-peers if that lma-service or across lma-services has a heartbeat interval of less than 60 seconds or the heartbeat retransmission timeout is less than 3 seconds, then it displays a configuration error.

CLI error displayed:

```
configure
contex pgw
lma-service lmav6
heartbeat interval 40
heartbeat monitor-max-peers
Failure: Recommended heartbeat interval: 60+, retransmission timeout: 3+, to
configure monitor-max-peers. Please retry.
heartbeat retransmission timeout 2
heartbeat monitor-max-peers
Failure: Recommended heartbeat interval: 60+, retransmission timeout: 3+, to
configure monitor-max-peers. Please retry.
end
```

```
configure
contex pgw
lma-service lmav6
heartbeat interval 60
heartbeat retransmission timeout 3
heartbeat monitor-max-peers
heartbeat interval 40
Failure: Recommended heartbeat interval: 60+, in presence of monitor-max-peers.
Please retry.
heartbeat retransmission timeout 2
Failure: Recommended heartbeat retransmission timeout: 3+, in presence of
monitor-max-peers. Please retry.
end
```

- Unusual logs are displayed as follows when there is more than 10% path failure and there is a delay in the detection of path failure.

“Retransmissions list size exceeds than expected, hb message will be sent with periodicty of configured HB interval for callid 20016”

show lma-service all



CHAPTER 30

L2TP Access Concentrator

This chapter describes the Layer 2 Tunneling Protocol (L2TP) Access Concentrator (LAC) functionality support on Cisco® ASR 5500 chassis and explains how it is configured.

The product Administration Guides provide examples and procedures for configuration of basic services on the system. It is recommended that you select the configuration example that best meets your service model, and configure the required elements for that model, as described in the respective product Administration Guide, before using the procedures in this chapter.



Important The L2TP Access Concentrator is a licensed Cisco feature. A separate feature license may be required. Contact your Cisco account representative for detailed information on specific licensing requirements. For information on installing and verifying licenses, refer to the *Managing License Keys* section of the *Software Management Operations* chapter in the *System Administration Guide*.

When enabled through the session license and feature use key, the system supports L2TP for encapsulation of data packets between it and one or more L2TP Network Server (LNS) nodes. In the system, this optional packet encapsulation, or tunneling, is performed by configuring L2TP Access Concentrator (LAC) services within contexts.



Important While establishing the L2TP session from LAC to LNS, the PPP connection for the user is established. The server uses CHAP authentication protocol to authenticate the connection. While calculating the CHAP response for the CHAP challenge received by the server, the server does not consider the CHAP password.



Important The LAC service uses UDP ports 13660 through 13668 as the source port for sending packets to the LNS.

This chapter contains the following topics:

- [Applicable Products and Relevant Sections, on page 714](#)
- [Supported LAC Service Configurations for PDSN Simple IP, on page 715](#)
- [Supported LAC Service Configurations for the GGSN and P-GW, on page 719](#)
- [Supported LAC Service Configuration for Mobile IP, on page 725](#)
- [Configuring Subscriber Profiles for L2TP Support, on page 728](#)
- [Feature Description, on page 731](#)

- [Configuring LAC Services, on page 732](#)
- [Modifying PDSN Services for L2TP Support, on page 734](#)
- [Modifying APN Templates to Support L2TP, on page 735](#)

Applicable Products and Relevant Sections

The LAC feature is supported for various products. The following table indicates the products on which the feature is supported and the relevant sections within the chapter that pertain to that product.

Applicable Product(s)	Refer to Sections
PDSN/FA/HA	<ul style="list-style-type: none"> • <i>Supported LAC Service Configurations for PDSN Simple IP</i> • <i>Supported LAC Service Configuration for Mobile IP</i> • <i>Configuring Subscriber Profiles for L2TP Support</i> <ul style="list-style-type: none"> • <i>RADIUS and Subscriber Profile Attributes Used</i> • <i>Configuring Local Subscriber Profiles for L2TP Support</i> • <i>Tunneling All Subscribers in a Specific Context Without Using RADIUS Attributes</i> • <i>Configuring LAC Services</i> • <i>Modifying PDSN Services for L2TP Support</i>
GGSN/SGSN/FA/P-GW	<ul style="list-style-type: none"> • <i>Supported LAC Service Configurations for the GGSN</i> • <i>Supported LAC Service Configuration for Mobile IP</i> • <i>Configuring Subscriber Profiles for L2TP Support</i> <ul style="list-style-type: none"> • <i>RADIUS and Subscriber Profile Attributes Used</i> • <i>Configuring Local Subscriber Profiles for L2TP Support</i> • <i>Enabling Multicast Services over L2TP</i> • <i>Configuring LAC Services</i> • <i>Modifying APN Templates to Support L2TP</i>
ASN GW	<ul style="list-style-type: none"> • <i>Supported LAC Service Configuration for Mobile IP</i> • <i>Configuring Subscriber Profiles for L2TP Support</i> <ul style="list-style-type: none"> • <i>RADIUS and Subscriber Profile Attributes Used</i> • <i>Configuring Local Subscriber Profiles for L2TP Support</i> • <i>Tunneling All Subscribers in a Specific Context Without Using RADIUS Attributes</i> • <i>Configuring LAC Services</i>

Supported LAC Service Configurations for PDSN Simple IP

LAC services can be applied to incoming PPP sessions using one of the following methods:

- **Attribute-based tunneling:** This method is used to encapsulate PPP packets for only specific users, identified during authentication. In this method, the LAC service parameters and allowed LNS nodes that may be communicated with are controlled by the user profile for the particular subscriber. The user profile can be configured locally on the system or remotely on a RADIUS server.
- **PDSN Service-based compulsory tunneling:** This method of tunneling is used to encapsulate all incoming PPP traffic from the R-P interface coming into a PDSN service, and tunnel it to an LNS peer for authentication. It should be noted that this method does not consider subscriber configurations, since all authentication is performed by the peer LNS.

Each LAC service is bound to a single system interface configured within the same system context. It is recommended that this context be a destination context as displayed in the following figure.

Figure 112: LAC Service Configuration for SIP

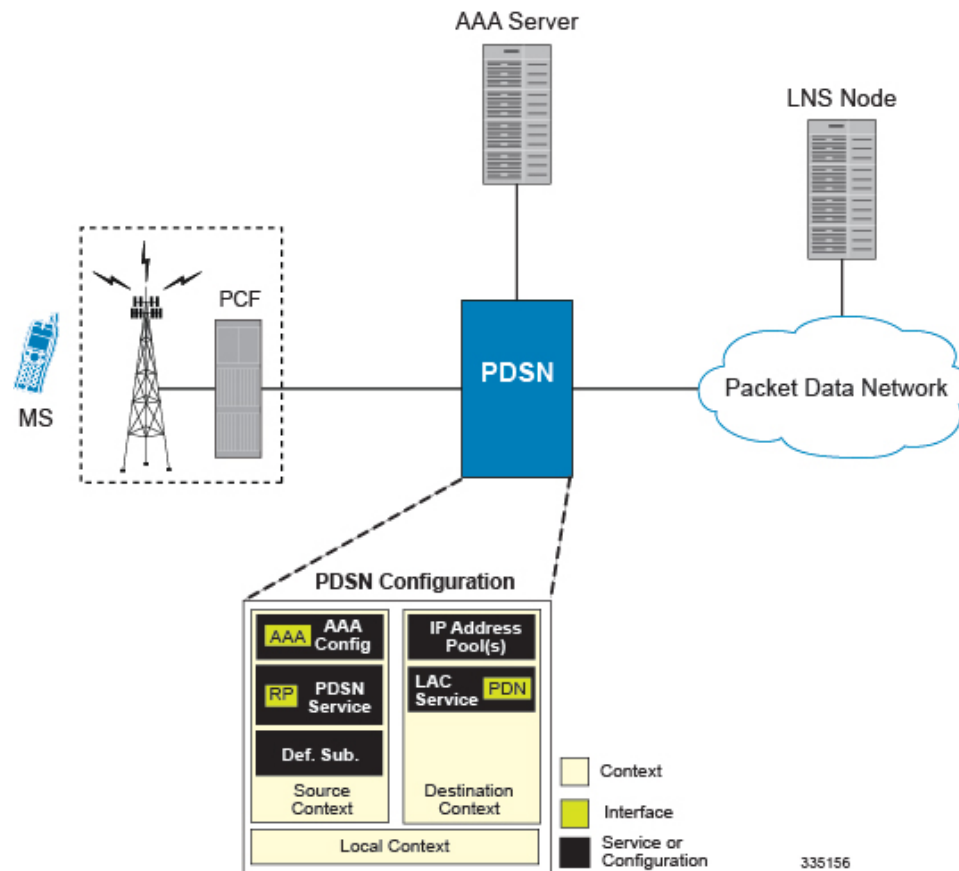

Attribute-based Tunneling

This section describes the working of attribute-based tunneling and its configuration.

How The Attribute-based L2TP Configuration Works

The following figure and the text that follows describe how Attribute-based tunneling is performed using the system.

Figure 113: Attribute-based L2TP Session Processing for SIP

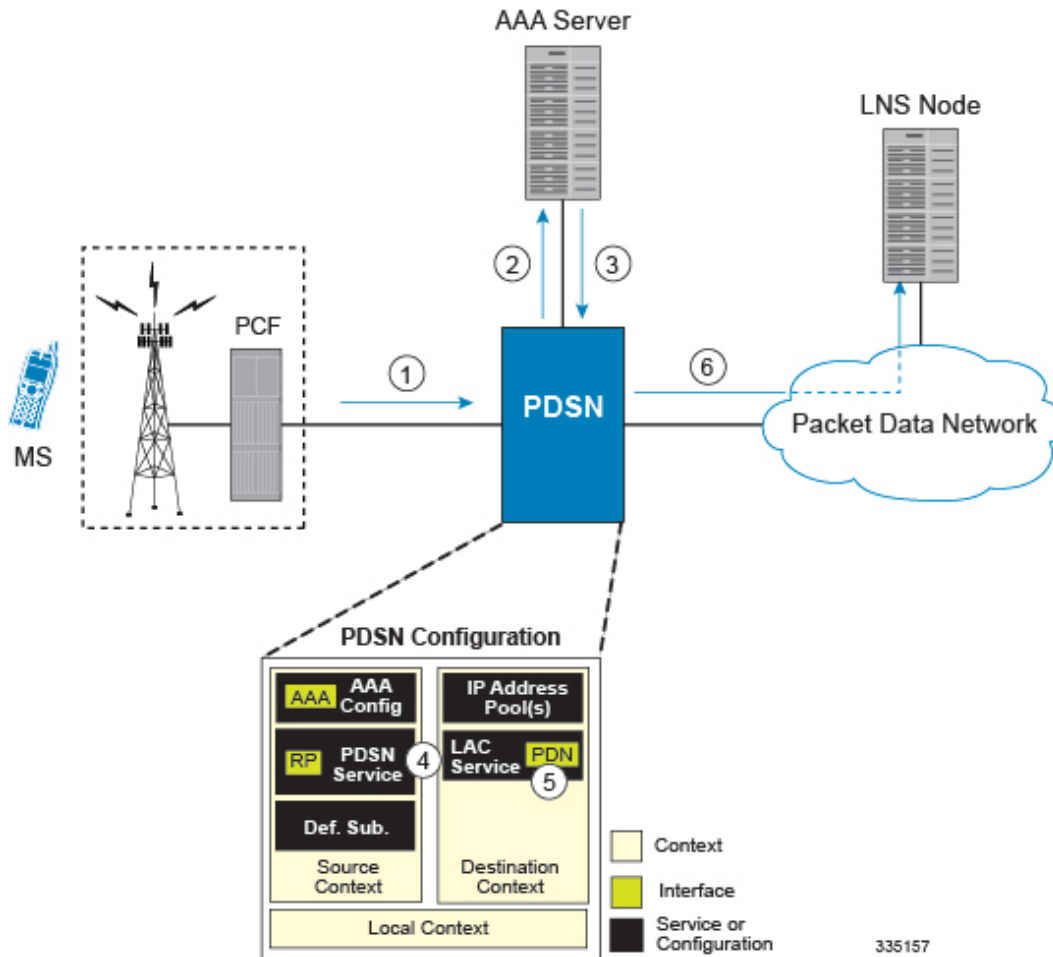

1. A subscriber session from the PCF is received by the PDSN service over the R-P interface.
2. The PDSN service attempts to authenticate the subscriber. The subscriber could be configured either locally or remotely on a RADIUS server. Figure above shows subscriber authentication using a RADIUS AAA server.
3. The RADIUS server returns an Access-Accept message, which includes attributes indicating that session data is to be tunneled using L2TP, and the name and location of the LAC service to use. An attribute could also be provided indicating the LNS peer to connect to.
4. The PDSN service receives the information and then forwards the packets to the LAC service, configured within the Destination context.
5. The LAC service, upon receiving the packets, encapsulates the information and forwards it to the appropriate PDN interface for delivery to the LNS.
6. The encapsulated packets are sent to the peer LNS through the packet data network where they will be un-encapsulated.

Configuring Attribute-based L2TP Support for PDSN Simple IP

This section provides a list of the steps required to configure attribute-based L2TP support for use with PDSN Simple IP applications. Each step listed refers to a different section containing the specific instructions for completing the required procedure.



Important These instructions assume that the system was previously configured to support subscriber data sessions as a PDSN.

-
- Step 1** Configure the subscriber profiles according to the information and instructions located in the *Configuring Subscriber Profiles for L2TP Support* section of this chapter.
 - Step 2** Configure one or more LAC services according to the information and instructions located in the *Configuring LAC Services* section of this chapter.
 - Step 3** Configure the PDSN service(s) with the tunnel context location according to the instructions located in the *Modifying PDSN Services for L2TP Support* section of this chapter.
 - Step 4** Save your configuration to flash memory, an external memory device, and/or a network location using the Exec mode command **save configuration**. For additional information on how to verify and save configuration files, refer to the *System Administration Guide* and the *Command Line Interface Reference*.
-

PDSN Service-based Compulsory Tunneling

This section describes the working of service-based compulsory tunneling and its configuration.

How PDSN Service-based Compulsory Tunneling Works

PDSN Service-based compulsory tunneling enables wireless operators to send all PPP traffic to remote LNS peers over an L2TP tunnel for authentication. This means that no PPP authentication is performed by the system.

Accounting start and interim accounting records are still sent to the local RADIUS server configured in the system's AAA Service configuration. When the L2TP session setup is complete, the system starts its call counters and signals the RADIUS server to begin accounting. The subscriber name for accounting records is based on the NAI-constructed name created for each session.

PDSN service-based compulsory tunneling requires the modification of one or more PDSN services and the configuration of one or more LAC services.

The following figure and the text that follows describe how PDSN service-based compulsory tunneling is performed using the system.

Figure 114: PDSN Service-based Compulsory Tunneling Session Processing

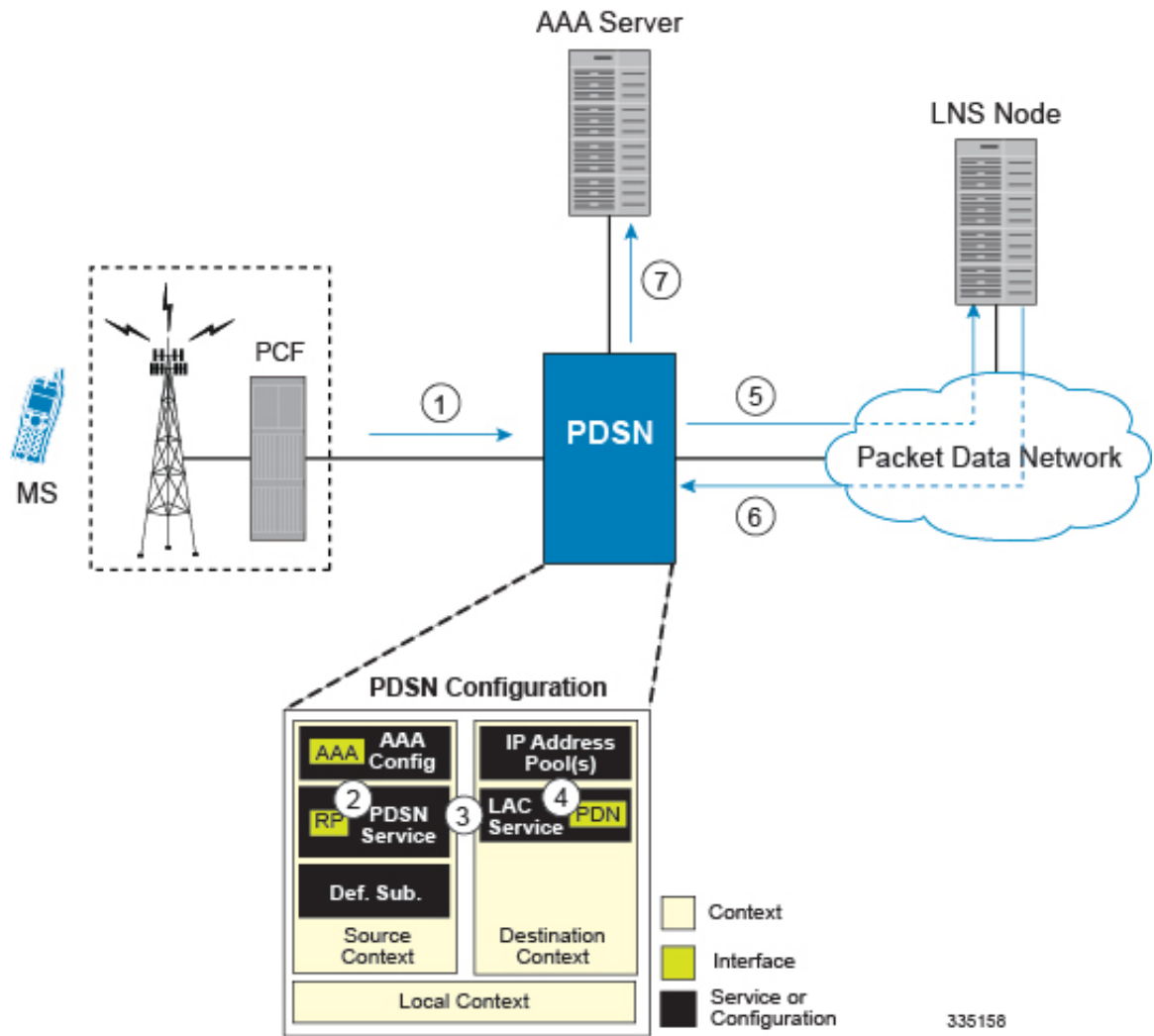

1. A subscriber session from the PCF is received by the PDSN service over the R-P interface.
2. The PDSN service detects its **tunnel-type** parameter is configured to L2TP and its **tunnel-context** parameter is configured to the Destination context.
3. The PDSN forwards all packets for the session to a LAC service configured in the Destination context. If multiple LAC services are configured, session traffic will be routed to each using a round-robin algorithm.
4. The LAC service initiates an L2TP tunnel to one of the LNS peers listed as part of its configuration.
5. Session packets are passed to the LNS over a packet data network for authentication.
6. The LNS authenticates the session and returns an Access-Accept to the PDSN.
7. The PDSN service initiates accounting for the session using a constructed NAI. Session data traffic is passed over the L2TP tunnel established in step 4.

Configuring L2TP Compulsory Tunneling Support for PDSN Simple IP

This section provides a list of the steps required to configure L2TP compulsory tunneling support for use with PDSN Simple IP applications. Each step listed refers to a different section containing the specific instructions for completing the required procedure.



Important These instructions assume that the system was previously configured to support subscriber data sessions as a PDSN.

-
- Step 1** Configure one or more LAC services according to the information and instructions located in the *Configuring LAC Services* section of this chapter.
 - Step 2** Configure the PDSN service(s) according to the instructions located in the *Modifying PDSN Services for L2TP Support* section of this chapter.
 - Step 3** Save your configuration to flash memory, an external memory device, and/or a network location using the Exec mode command **save configuration**. For additional information on how to verify and save configuration files, refer to the *System Administration Guide* and the *Command Line Interface Reference*.
-

Supported LAC Service Configurations for the GGSN and P-GW

As mentioned previously, L2TP is supported through the configuration of LAC services on the system. Each LAC service is bound to a single system interface configured within the same system destination context as displayed in following figure.

Figure 115: GGSN LAC Service Configuration

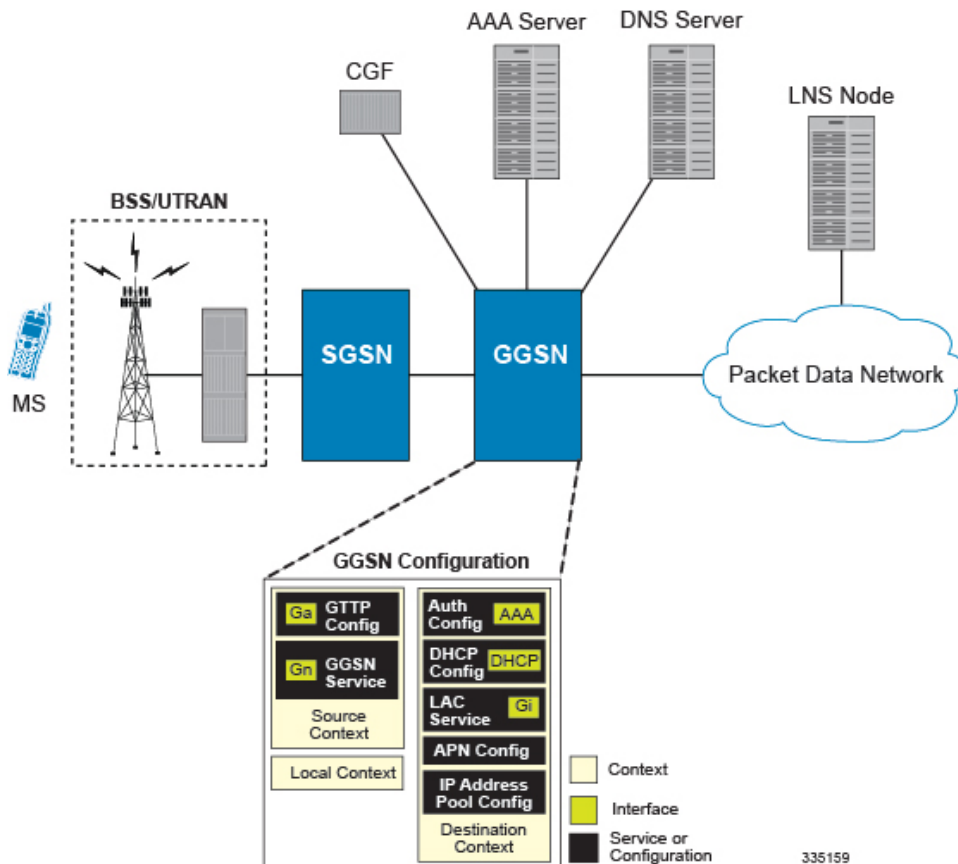

LAC services are applied to incoming subscriber PDP contexts based on the configuration of attributes either in the GGSN's Access Point Name (APN) templates or in the subscriber's profile. Subscriber profiles can be configured locally on the system or remotely on a RADIUS server.

LAC service also supports domain-based L2TP tunneling with LNS. This method is used to create multiple tunnels between LAC and LNS on the basis of values received in "Tunnel-Client-Auth-ID" or "Tunnel-Server-Auth-ID" attribute received from AAA Server in Access-Accept as a key for tunnel selection and creation. When the LAC needs to establish a new L2TP session, it first checks if there is any existing L2TP tunnel with the peer LNS based on the value of key "Tunnel-Client-Auth-ID" or "Tunnel-Server-Auth-ID" attribute. If no such tunnel exists for the key, it will create a new Tunnel with the LNS.

If LAC service needs to establish a new tunnel for new L2TP session with LNS and the tunnel create request fails because maximum tunnel creation limit is reached, LAC will try other LNS addresses received from AAA server in Access-Accept message. If all available peer-LNS are exhausted, LAC service will reject the call

L2TP tunnel parameters are configured within the APN template and are applied to all subscribers accessing the APN. However, L2TP operation will differ depending on the subscriber's PDP context type as described below:

- **Transparent IP:** The APN template's L2TP parameter settings will be applied to the session.
- **Non-transparent IP:** Since authentication is required, L2TP parameter attributes in the subscriber profile (if configured) will take precedence over the settings in the APN template.

- **PPP:** The APN template's L2TP parameter settings will be applied and all of the subscriber's PPP packets will be forwarded to the specified LNS.

More detailed information is located in the sections that follow.

Transparent IP PDP Context Processing with L2TP Support

The following figure and the text that follows describe how transparent IP PDP contexts are processed when L2TP tunneling is enabled.

Figure 116: Transparent IP PDP Context Call Processing with L2TP Tunneling

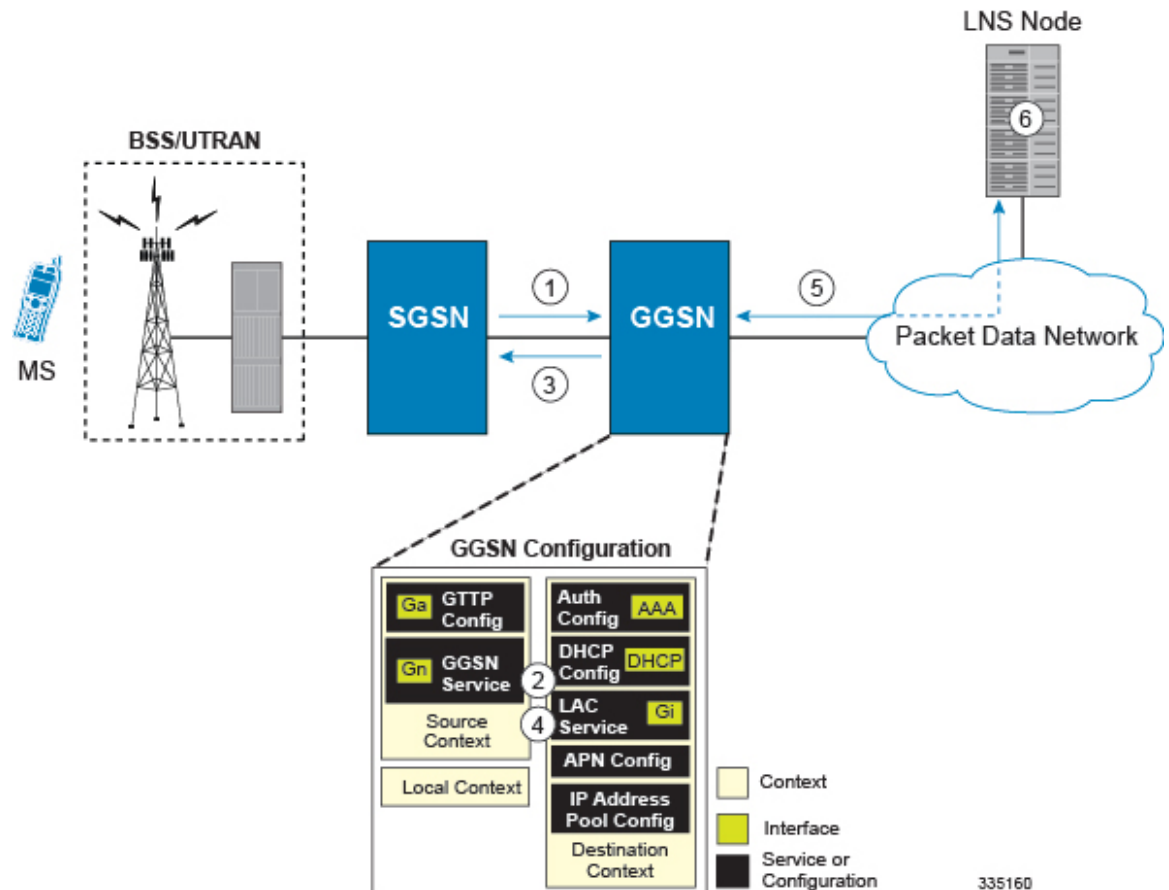

1. A Create PDP Context Request message for a subscriber session is sent from the SGSN to the GGSN service over the Gn interface. The message contains information such as the PDP Type, APN, and charging characteristics.
2. The GGSN determines whether or not it is configured with an APN identical to the one specified in the message. If so, it determines how to process the session based on the configuration of the APN.

The APN configuration indicates such things as the IP address of the LNS, the system destination context in which a LAC service is configured, and the outbound username and password that will be used by the LNS to authenticate incoming sessions. If no outbound information is configured, the subscriber's International Mobile Subscriber Identity (IMSI) is used as the username at the peer LNS.

1. The GGSN returns an affirmative Create PDP Context Response to the SGSN over the Gn interface.
2. The GGSN passes data received from the MS to a LAC service.
3. The LAC service encapsulates the IP packets and forwards it to the appropriate Gi interface for delivery to the LNS.
4. The LNS un-encapsulates the packets and processes them as needed. The processing includes IP address allocation.

Non-transparent IP PDP Context Processing with L2TP Support

The following figure and the text that follows describe how non-transparent IP PDP contexts are processed when L2TP tunneling is enabled.

Figure 117: Non-transparent IP PDP Context Call Processing with L2TP Tunneling

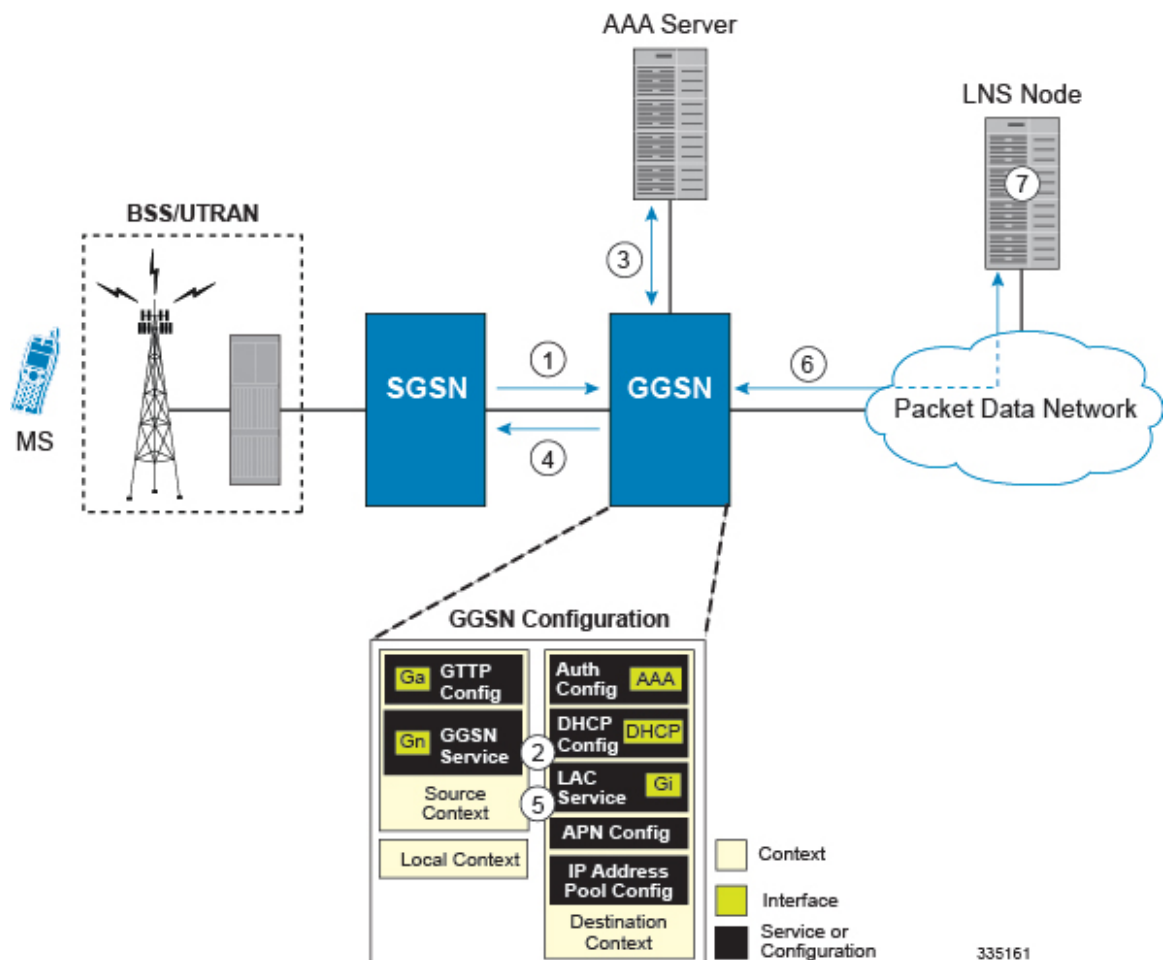

1. A Create PDP Context Request message for a subscriber session is sent from the SGSN to the GGSN service over the Gn interface. The message contains information such as the PDP Type, APN, and charging characteristics.

2. The GGSN determines whether or not it is configured with an APN identical to the one specified in the message. If so, it determines how to process the session based on the configuration of the APN.

The APN configuration indicates such things as the IP address of the LNS, the system destination context in which a LAC service is configured, and the outbound username and password that will be used by the LNS to authenticate incoming sessions. If no outbound information is configured, the subscriber's username is sent to the peer LNS.

3. The GGSN service authenticates the subscriber. The subscriber could be configured either locally or remotely on a RADIUS server. Figure above shows subscriber authentication using a RADIUS AAA server.

As part of the authentication, the RADIUS server returns an Access-Accept message.

The message may include attributes indicating that session data is to be tunneled using L2TP, and the name and location of the LAC service to use. An attribute could also be provided indicating the LNS peer to connect to.

If these attributes are supplied, they take precedence over those specified in the APN template.

4. The GGSN returns an affirmative Create PDP Context Response to the SGSN over the Gn interface.
5. The GGSN passes data received from the MS to a LAC service.
6. The LAC service encapsulates the IP packets and forwards it to the appropriate Gi interface for delivery to the LNS.
7. The LNS un-encapsulates the packets and processes them as needed. The processing includes authentication and IP address allocation.

PPP PDP Context Processing with L2TP Support

The following figure and the text that follows describe how non-transparent IP PDP contexts are processed when L2TP tunneling is enabled.

Figure 118: PPP PDP Context Call Processing with L2TP Tunneling

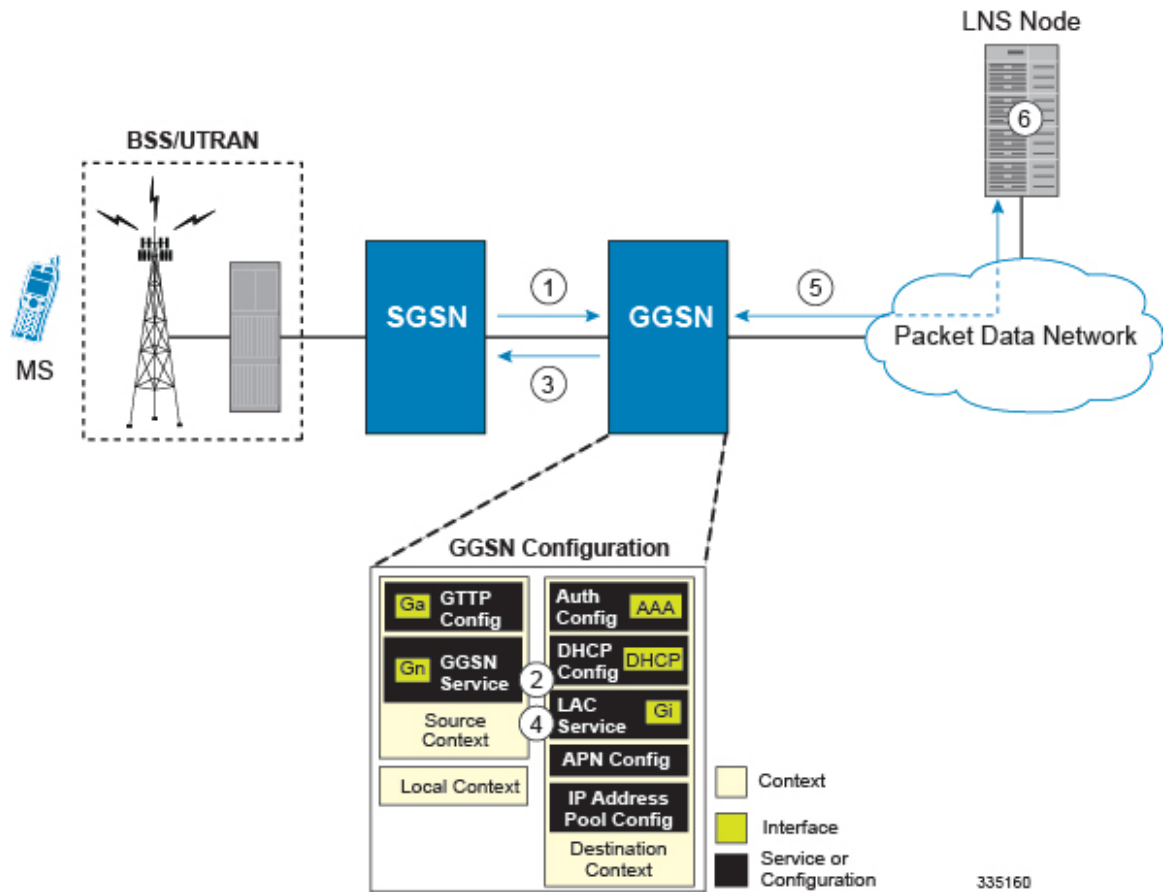

1. A Create PDP Context Request message for a subscriber session is sent from the SGSN to the GGSN service over the Gn interface. The message contains information such as the PDP Type, APN, and charging characteristics.
2. The GGSN determines whether or not it is configured with an APN identical to the one specified in the message. If so, it determines how to process the session based on the configuration of the APN.

The APN configuration indicates such things as the IP address of the LNS, the system destination context in which a LAC service is configured.

Note that L2TP support could also be configured in the subscriber's profile. If the APN is not configured for L2TP tunneling, the system will attempt to authenticate the subscriber. The tunneling parameters in the subscriber's profile would then be used to determine the peer LNS.

3. The GGSN returns an affirmative Create PDP Context Response to the SGSN over the Gn interface.
4. The GGSN passes the PPP packets received from the MS to a LAC service.
5. The LAC service encapsulates the PPP packets and forwards it to the appropriate Gi interface for delivery to the LNS.
6. The LNS un-encapsulates the packets and processes them as needed. The processing includes PPP termination, authentication (using the username/password provided by the subscriber), and IP address allocation.

Configuring the GGSN or P-GW to Support L2TP

This section provides a list of the steps required to configure the GGSN or P-GW to support L2TP. Each step listed refers to a different section containing the specific instructions for completing the required procedure.



Important These instructions assume that the system was previously configured to support subscriber data sessions as a GGSN or P-GW.

Step 1 Configure the APN template to support L2TP tunneling according to the information and instructions located in the *Modifying APN Templates to Support L2TP* section of this chapter.

Important L2TP tunneling can be configured within individual subscriber profiles as opposed/or in addition to configuring support with an APN template. Subscriber profile configuration is described in the *Configuring Subscriber Profiles for L2TP Support* section of this chapter.

Step 2 Configure one or more LAC services according to the information and instructions located in the *Configuring LAC Services* section of this chapter.

Step 3 Save your configuration to flash memory, an external memory device, and/or a network location using the Exec mode command **save configuration**. For additional information on how to verify and save configuration files, refer to the *System Administration Guide* and the *Command Line Interface Reference*.

Supported LAC Service Configuration for Mobile IP

LAC services can be applied to incoming MIP sessions using attribute-based tunneling. Attribute-based tunneling is used to encapsulate PPP packets for specific users, identified during authentication. In this method, the LAC service parameters and allowed LNS nodes that may be communicated with are controlled by the user profile for the particular subscriber. The user profile can be configured locally on the system or remotely on a RADIUS server.

Each LAC service is bound to a single system interface within the same system context. It is recommended that this context be a destination context as displayed in figure below.

Figure 119: LAC Service Configuration for MIP

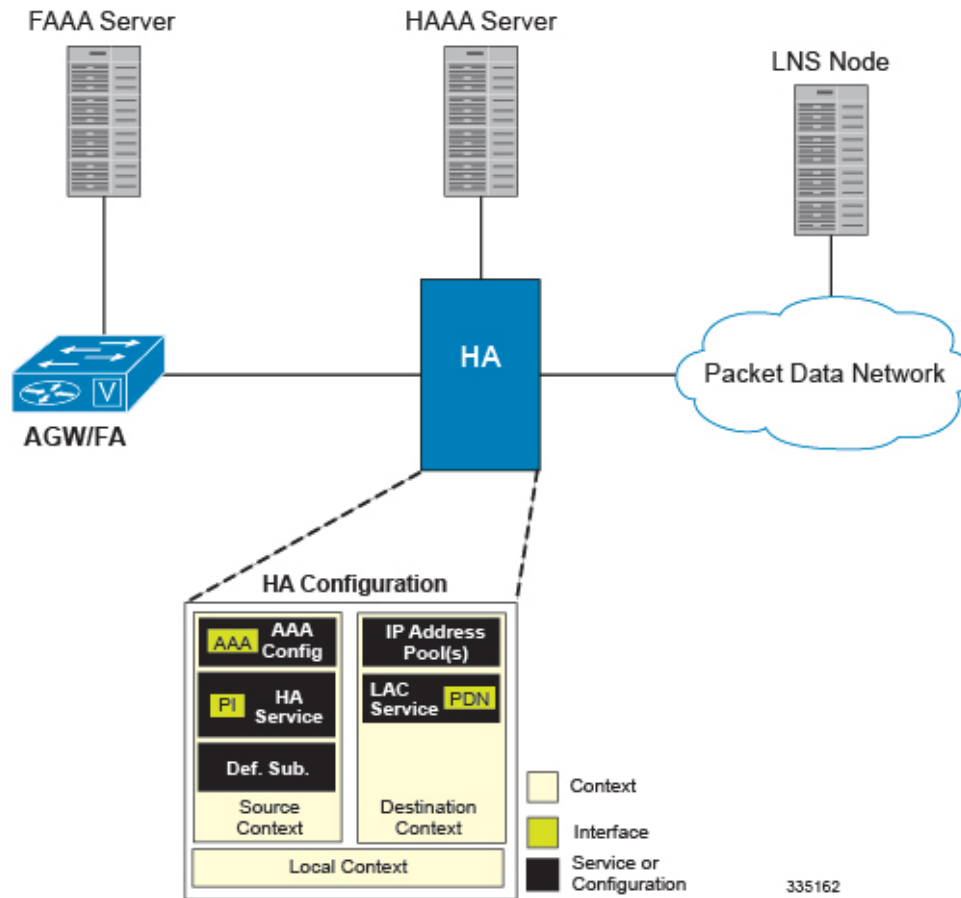

How The Attribute-based L2TP Configuration for MIP Works

The following figure and the text that follows describe how Attribute-based tunneling for MIP is performed using the system.

Figure 120: Attribute-based L2TP Session Processing for MIP

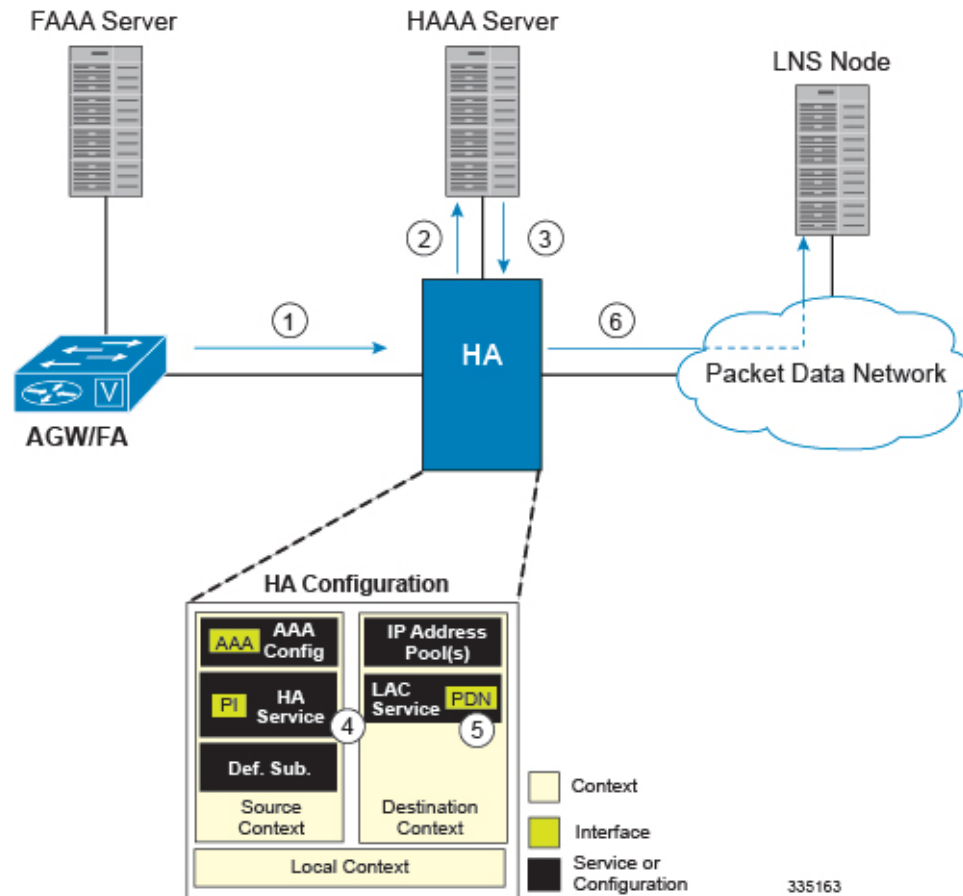

1. A subscriber session from the FA is received by the HA service over the Pi interface.
2. The HA service attempts to authenticate the subscriber. The subscriber could be configured either locally or remotely on a RADIUS server. Figure above shows subscriber authentication using a RADIUS AAA server.
3. The RADIUS server returns an Access-Accept message, which includes attributes indicating that session data is to be tunneled using L2TP, and the name and location of the LAC service to use. An attribute could also be provided indicating the LNS peer to connect to.
4. The HA service receives the information and then forwards the packets to the LAC service, configured within the Destination context.
5. The LAC service, upon receiving the packets, encapsulates the information and forwards it to the appropriate PDN interface for delivery to the LNS.
6. The encapsulated packets are sent to the peer LNS through the packet data network where they will be un-encapsulated.

Configuring Attribute-based L2TP Support for HA Mobile IP

This section provides a list of the steps required to configure attribute-based L2TP support for use with HA Mobile IP applications. Each step listed refers to a different section containing the specific instructions for completing the required procedure.



Important These instructions assume that the system was previously configured to support subscriber data sessions as an HA.

- Step 1** Configure the subscriber profiles according to the information and instructions located in the *Configuring Subscriber Profiles for L2TP Support* section of this chapter.
- Step 2** Configure one or more LAC services according to the information and instructions located in the *Configuring LAC Services* section of this chapter.
- Step 3** Save your configuration to flash memory, an external memory device, and/or a network location using the Exec mode command **save configuration**. For additional information on how to verify and save configuration files, refer to the *System Administration Guide* and the *Command Line Interface Reference*.

Configuring Subscriber Profiles for L2TP Support

This section provides information and instructions on the following procedures:

- [RADIUS and Subscriber Profile Attributes Used, on page 728](#)
- [Configuring Local Subscriber Profiles for L2TP Support, on page 730](#)
- [Configuring Local Subscriber, on page 731](#)
- [Verifying the L2TP Configuration, on page 731](#)



Important Since the instructions for configuring subscribers differ between RADIUS server applications, this section only provides the individual attributes that can be added to the subscriber profile. Refer to the documentation that shipped with your RADIUS server for instructions on configuring subscribers.

RADIUS and Subscriber Profile Attributes Used

Attribute-based L2TP tunneling is supported through the use of attributes configured in subscriber profiles stored either locally on the system or remotely on a RADIUS server. The following table describes the attributes used in support of LAC services. These attributes are contained in the standard and VSA dictionaries.

Table 67: Subscriber Attributes for L2TP Support

RADIUS Attribute	Local Subscriber Attribute	Description	Variable
Tunnel-Type	tunnel l2tp	Specifies the type of tunnel to be used for the subscriber session	L2TP
Tunnel-Server-Endpoint	tunnel l2tp peer-address	Specifies the IP address of the peer LNS to connect tunnel to.	IPv4 address in dotted-decimal format, enclosed in quotation m

RADIUS Attribute	Local Subscriber Attribute	Description	Variable
Tunnel-Password	tunnel l2tp secret	Specifies the shared secret between the LAC and LNS.	Alpha and or numeric string to 63 characters, enclosed in quotation marks
Tunnel-Private-Group-ID	tunnel l2tp tunnel-context	Specifies the name of the destination context configured on the system in which the LAC service(s) to be used are located. Important If the LAC service and egress interface are configured in the same context as the core service or HA service, this attribute is not needed.	Alpha and or numeric string to 63 characters, enclosed in quotation marks
Tunnel-Preference	tunnel l2tp preference	Configures the priority of each peer LNS when multiple LNS nodes are configured. Important This attribute is only used when the loadbalance-tunnel-peers parameter or SN-Tunnel-Load-Balancing attribute configured to prioritized.	Integer from 1 to 65535
SN-Tunnel-Load-Balancing	loadbalance-tunnel-peer	A vendor-specific attribute (VSA) used to provides a selection algorithm defining how an LNS node is selected by the RADIUS server when multiple LNS peers are configured within the subscriber profile.	<ul style="list-style-type: none"> • Random - Random LNS selection order, the Tunnel-Preference attribute is not used in determining which LNS to select. • Balanced - LNS selected using sequential balancing across all configured LNS nodes, the Tunnel-Preference attribute is not used in determining which LNS to select. • Prioritized - LNS selected based on the priority assigned in the Tunnel-Preference attribute.

RADIUS Attribute	Local Subscriber Attribute	Description	Variable
Client-Endpoint	local-address	Specifies the IP address of a specific LAC service configured on the system that to use to facilitate the subscriber's L2TP session. This attribute is used when multiple LAC services are configured.	IPv4 address in dotted decimal notation. (xxx.xxx.xxx.xxx)

RADIUS Tagging Support

The system supports RADIUS attribute tagging for tunnel attributes. These "tags" organize together multiple attributes into different groups when multiple LNS nodes are defined in the user profile. Tagging is useful to ensure that the system groups all the attributes used for a specific server. If attribute tagging is not supported by your specific RADIUS server, the system implicitly organizes the attributes in the order that they are listed in the access accept packet.

Configuring Local Subscriber Profiles for L2TP Support

This section provides information and instructions for configuring local subscriber profiles on the system to support L2TP.



Important

The configuration of RADIUS-based subscriber profiles is not discussed in this document. Please refer to the documentation supplied with your RADIUS server for further information.



Important

This section provides the minimum instruction set for configuring local subscriber profile for L2TP support on the system. For more information on commands that configure additional parameters and options, refer to the *LAC Service Configuration Mode Commands* chapter in the *Command Line Interface Reference*.

To configure the system to provide L2TP support to subscribers:

-
- Step 1** Configure the "Local" subscriber with L2TP tunnel parameters and the load balancing parameters with action by applying the example configuration in the *Configuring Local Subscriber* section.
 - Step 2** Verify your L2TP configuration by following the steps in the *Verifying the L2TP Configuration* section.
 - Step 3** Save your configuration to flash memory, an external memory device, and/or a network location using the Exec mode command **save configuration**. For additional information on how to verify and save configuration files, refer to the *System Administration Guide* and the *Command Line Interface Reference*.
-

Configuring Local Subscriber

Use the following example to configure the Local subscriber with L2TP tunnel parameters. Optionally you can configure load balancing between multiple LNS servers:

```
configure
  context <ctxt_name> [-noconfirm]
    subscriber name <subs_name>
      tunnel l2tp peer-address <lms_ip_address> [ preference <integer> | [
encrypted ] secret <secret_string> | tunnel-context <context_name> | local-address
<local_ip_address> ]
      load-balancing { random | balanced | prioritized }
    end
```

Notes:

- <ctxt_name> is the system context in which you wish to configure the subscriber profile.
- <lms_ip_address> is the IP address of LNS server node and <local_ip_address> is the IP address of system which is bound to LAC service.

Verifying the L2TP Configuration

These instructions are used to verify the L2TP configuration.

Verify that your L2TP configurations were configured properly by entering the following command in Exec Mode in specific context:

```
show subscriber configuration username user_name
```

The output of this command is a concise listing of subscriber parameter settings as configured.

Tunneling All Subscribers in a Specific Context Without Using RADIUS Attributes

As with other services supported by the system, values for subscriber profile attributes not returned as part of a RADIUS Access-Accept message can be obtained using the locally configured profile for the subscriber named default. The subscriber profile for default must be configured in the AAA context (i.e. the context in which AAA functionality is configured).

As a time saving feature, L2TP support can be configured for the subscriber named default with no additional configuration for RADIUS-based subscribers. This is especially useful when you have separate source/AAA contexts for specific subscribers.

To configure the profile for the subscriber named default, follow the instructions above for configuring a local subscriber and enter the name default.

Feature Description

When a multicast service is set up for the mobile Customer Premises Equipment (CPE), the APN is configured with L2TP tunnel and P-GW works as L2TP Access Concentrator (LAC). To set up the multicast session, the

video client/mobile CPE need to send or receive the PIM (Protocol Independent Multicast) message (with TTL=1) to or from Video headend server over SGi L2TP tunnel.

The P-GW follows the default L2TP LAC to inspect and process the encapsulated IP traffic inside the L2TP tunnel. This process prevents certain applications between CPE and LNS that sends TTL=1 traffic to function. Prior to 21.21.1 release, when an IP packet is sent, the Time to Live (TTL) value (for example, 255) was decremented by 1 at each hop. The P-GW dropped the packet with TTL value 0 or 1, decremented (when TTL > 1) the TTL value and the new checksum for the data packet was calculated. In this release, by enabling multicast session over L2TP feature through CLI:

- P-GW ignores the TTL value and forwards the packet.
- The L2TP and regular packets gets differentiated by L2TP tunnel type at `sessmgr_ipv4.c` and it verifies the CLI configuration mode enabled.

Configuring LAC Services



Important Not all commands, keywords and functions may be available. Functionality is dependent on platform and license(s).

This section provides information and instructions for configuring LAC services on the system allowing it to communicate with peer LNS nodes.



Important This section provides the minimum instruction set for configuring LAC service support on the system. For more information on commands that configure additional parameters and options, refer to the *LAC Service Configuration Mode Commands* chapter in the *Command Line Interface Reference*.

To configure the LAC services on system:

-
- Step 1** Configure the LAC service on system and bind it to an IP address by applying the example configuration in the *Configuring LAC Service* section.
 - Step 2** *Optional.* Configure LNS peer information if the Tunnel-Service-Endpoint attribute is not configured in the subscriber profile or PDSN compulsory tunneling is supported by applying the example configuration in the *Configuring LNS Peer* section.
 - Step 3** Verify your LAC configuration by following the steps in the Verifying the LAC Service Configuration section.
 - Step 4** Save your configuration to flash memory, an external memory device, and/or a network location using the Exec mode command **save configuration**. For additional information on how to verify and save configuration files, refer to the *System Administration Guide* and the *Command Line Interface Reference*.
-

Configuring LAC Service

Use the following example to create the LAC service and bind the service to an IP address:

```

configure
  context <dst_ctxt_name> [-noconfirm]
    lac-service <service_name>
      bind address <ip_address>
    end

```

Notes:

- <dst_ctxt_name> is the destination context where you want to configure the LAC service.

Configuring Multicast Services over L2TP

Use the following CLI commands to enable or disable the multicast session over L2TP feature. By default, this feature is disabled.

```

configure
  context context_name
    lac-service service_name
      ttl-ignore
    end

```

Notes:

- **ttl-ignore**: Ignores the TTL value and forwards the packets.

Configuring LNS Peer

Use the following example to configure the LNS peers and load balancing between multiple LNS peers:

```

configure
  context <dst_ctxt_name> [ -noconfirm ]
    lac-service <service_name>
      tunnel selection-key tunnel-server-auth-id
      peer-lns <ip_address> [encrypted] secret <secret> [crypto-map <map_name>
      {[encrypted] isakmp-secret <secret> }] [description <text>] [ preference <integer>]

      load-balancing { random | balanced | prioritized }
    end

```

Notes:

- <dst_ctxt_name> is the destination context where the LAC service is configured.

Verifying the LAC Service Configuration

These instructions are used to verify the LAC service configuration.

Verify that your LAC service configurations were configured properly by entering the following command in Exec Mode in specific context:

```
show lac-service name service_name
```

The output given below is a concise listing of LAC service parameter settings as configured.

```

Service name: vpn1
Context:                ispl
Bind:                   Done
Local IP Address:       192.168.2.1
First Retransmission Timeout: 1 (secs)
Max Retransmission Timeout: 8 (secs)
Max Retransmissions:    5
Max Sessions:           500000      Max Tunnels: 32000
Max Sessions Per Tunnel: 512
Data Sequence Numbers: Enabled      Tunnel Authentication: Enabled
Keep-alive interval:    60           Control receive window: 16
Max Tunnel Challenge Length: 16
Proxy LCP Authentication: Enabled
Load Balancing:         Random
Service Status:         Started
Newcall Policy:         None

```

Modifying PDSN Services for L2TP Support

PDSN service modification is required for compulsory tunneling and optional for attribute-based tunneling.

For attribute-based tunneling, a configuration error could occur such that upon successful authentication, the system determines that the subscriber session requires L2TP but cannot determine the name of the context in which the appropriate LAC service is configured from the attributes supplied. As a precautionary, a parameter has been added to the PDSN service configuration options that will dictate the name of the context to use. It is strongly recommended that this parameter be configured.

This section contains instructions for modifying the PDSN service configuration for either compulsory or attribute-based tunneling.



Important This section provides the minimum instruction set for modifying PDSN service for L2TP support on the system. For more information on commands that configure additional parameters and options, refer to the *LAC Service Configuration Mode Commands* chapter in the *Command Line Interface Reference*.

To configure the LAC services on system:

- Step 1** Modify the PDSN service to support L2TP by associating LAC context and defining tunnel type by applying the example configuration in the *Modifying PDSN Service* section.
- Step 2** Verify your configuration to modify PDSN service by following the steps in the *Verifying the PDSN Service for L2TP Support* section.
- Step 3** Save your configuration to flash memory, an external memory device, and/or a network location using the Exec mode command **save configuration**. For additional information on how to verify and save configuration files, refer to the *System Administration Guide* and the *Command Line Interface Reference*.

Modifying PDSN Service

Use the following example to modify the PDSN service to support L2TP by associating LAC context and defining tunnel type:

```
configure
context <source_ctxt_name> [ -noconfirm ]
  pdsn-service <pdsn_service_name>
    ppp tunnel-context <lac_context_name>
    ppp tunnel-type { l2tp | none }
  end
```

Notes:

- <source_ctxt_name> is the name of the source context containing the PDSN service, which you want to modify for L2TP support.
- <pdsn_service_name> is the name of the pre-configured PDSN service, which you want to modify for L2TP support.
- <lac_context_name> is typically the destination context where the LAC service is configured.

Verifying the PDSN Service for L2TP Support

These instructions are used to verify the PDSN service configuration.

Verify that your PDSN is configured properly by entering the following command in Exec Mode in specific context:

```
show pdsn-service name <pdsn_service_name>
```

The output of this command is a concise listing of PDSN service parameter settings as configured.

Modifying APN Templates to Support L2TP

This section provides instructions for adding L2TP support for APN templates configured on the system.



Important This section provides the minimum instruction set for configuring LAC service support on the system. For more information on commands that configure additional parameters and options, refer to the *LAC Service Configuration Mode Commands* chapter in the *Command Line Interface Reference*.

To configure the LAC services on system:

-
- Step 1** Modify the APN template to support L2TP with LNS server address and other parameters by applying the example configuration in the *Assigning LNS Peer Address in APN Template* section.
 - Step 2** Optional. If L2TP will be used to tunnel transparent IP PDP contexts, configure the APN's outbound username and password by applying the example configuration in the *Configuring Outbound Authentication* section.
 - Step 3** Verify your APN configuration by following the steps in the *Verifying the APN Configuration* section.

- Step 4** Save your configuration to flash memory, an external memory device, and/or a network location using the Exec mode command **save configuration**. For additional information on how to verify and save configuration files, refer to the *System Administration Guide* and the *Command Line Interface Reference*.

Assigning LNS Peer Address in APN Template

Use following example to assign LNS server address with APN template:

```
configure
context <dst_ctxt_name> [-noconfirm]
  apn <apn_name>
    tunnel l2tp [ peer-address <lns_address> [ [ encrypted ] secret
<l2tp_secret> ] [ preference <integer> ] [ tunnel-context <l2tp_context_name> ] [
local-address <local_ip_address> ] [ crypto-map <map_name> { [ encrypted ]
isakmp-secret <crypto_secret> } ]
    end
```

Notes:

- *<dst_ctxt_name>* is the name of system destination context in which the APN is configured.
- *<apn_name>* is the name of the pre-configured APN template which you want to modify for the L2TP support.
- *<lns_address>* is the IP address of LNS server node and *<local_ip_address>* is the IP address of system which is bound to LAC service.

Configuring Outbound Authentication

Use the following example to configure the LNS peers and load balancing between multiple LNS peers:

```
configure
context <dst_ctxt_name> [ -noconfirm ]
  apn <apn_name>
    outbound { [ encrypted ] password <pwd> | username <name> }
    end
```

Notes:

- *<dst_ctxt_name>* is the destination context where APN template is is configured.
- *<apn_name>* is the name of the pre-configured APN template which you want to modify for the L2TP support.

Verifying the APN Configuration

These instructions are used to verify the APN configuration.

Verify that your APN configurations were configured properly by entering the following command in Exec Mode in specific context:

```
show apn name apn_name
```

The output is a concise listing of APN parameter settings as configured.



CHAPTER 31

LBO Restriction on Downlink and Uplink Data Volume Transfer

This chapter describes the following topics:

- [Feature Summary and Revision History, on page 739](#)
- [Feature Description, on page 740](#)
- [How It Works, on page 740](#)
- [Configuring the LBO Restriction on Downlink and Uplink Data Volume Transfer, on page 740](#)
- [Monitoring and Troubleshooting the LBO Restriction on Downlink and Uplink Data Volume Transfer, on page 741](#)

Feature Summary and Revision History

Summary Data

Applicable Product(s) or Functional Area	<ul style="list-style-type: none">• P-GW• SAEGW
Applicable Platform(s)	ASR 5500
Feature Default	Disabled - Configuration Required
Related Changes in This Release	Not Applicable
Related Documentation	<ul style="list-style-type: none">• <i>Command Line Interface Reference</i>• <i>P-GW Administration Guide</i>• <i>SAEGW Administration Guide</i>

Revision History

Revision Details	Release
First introduced.	21.5

Feature Description

After the subscriber quota is exhausted, all the ongoing download of files must be terminated and the UE must be allowed access to only user-defined servers (Self-Care Portal).

This feature achieves the functionality of Local Break Out (LBO) restriction on Downlink and Uplink data volume transfer by CLI-controlled mechanism.

How It Works

Following is a brief overview of how the feature works:

1. User is redirected to the portal and enters an OTP. The subscriber session continues after authentication.
2. Internet rule and Default rules are installed by PCRF and quota is granted by the OCS.
3. After the subscriber quota is exhausted, the PCRF installs a Self-Care Readdress rule and removes the previously installed Internet rule.
4. After the Readdress rule is applied:
 - For UDP: The ongoing Downlink packets are discarded while all the new uplink packets are readdressed to Self-Care Portal.
 - For TCP: All the existing flows matching the Internet rule are terminated by sending FIN to UE and RST to the server.

Limitation

Post installation of readdress rule, first packet is charged but not sent to the UE. Subsequent packets are not charged or sent to the UE.

Configuring the LBO Restriction on Downlink and Uplink Data Volume Transfer

This section provides information about the CLI commands available in support of the feature.

Enabling the LBO Restriction on Downlink and Uplink Data Volume Transfer

Use the following configuration in ACS Rulebase Configuration Mode to enable the feature.

```
configure
  active-charging service service_name
  rulebase rulebase_name
    ip readdress failure-action terminate
    { default | no } ip readdress failure-action
  end
```

NOTES:

- **ip readdress**: Configures the IP Readdress options.
- **failure-action**: Configures the failure action for IP Readdress.
- **terminate**: Terminates the flow
- If previously configured, use the { **default | no** } **ip readdress failure-action** CLI command to disable the feature.

Monitoring and Troubleshooting the LBO Restriction on Downlink and Uplink Data Volume Transfer

This section describes the CLI commands available to monitor and/or troubleshoot the feature.

Show Commands and/or Outputs

show active-charging rulebase statistics

The output of this CLI command has been enhanced in support of the feature. The following existing counters will be updated when Readdressing fails for UDP:

- Total Readdressing Failures
- Dropped Pkts

show active-charging sessions full all

The output of this CLI command has been enhanced in support of the feature. The following existing counter will be updated when Readdressing fails for TCP flow:

- Flow action Terminated Flows

show active-charging charging-action statistics name <charging_action_name>

The output of this CLI command has been enhanced in support of the feature. The following existing counter will be updated when Readdressing fails for TCP flow:

- Terminate Flow

show active-charging service statistics

The output of this CLI command has been enhanced in support of the feature. The following existing counter will be updated when Readdressing fails for UDP:

- Dropped Pkts



CHAPTER 32

LTE to Wi-Fi (S2bGTP) Seamless Handover

This chapter describes the following topics:

- [Feature Summary and Revision History, on page 743](#)
- [Feature Description, on page 744](#)
- [How It Works, on page 744](#)
- [Configuring LTE to Wi-Fi Seamless Handover, on page 746](#)
- [Monitoring and Troubleshooting, on page 746](#)

Feature Summary and Revision History

Summary Data

Applicable Product(s) or Functional Area	<ul style="list-style-type: none">• P-GW• SAEGW
Applicable Platform(s)	<ul style="list-style-type: none">• ASR 5500• VPC - DI• VPC - SI
Feature Default	Disabled - Configuration Required
Related Changes in This Release	Not Applicable
Related Documentation	<ul style="list-style-type: none">• <i>Command Line Interface Reference</i>• <i>P-GW Administration Guide</i>• <i>SAEGW Administration Guide</i>• <i>Statistics and Counters Reference</i>

Revision History



Important Revision history details are not provided for features introduced before release 21.2 and N5.1.

Revision Details	Release
With this release, support has been added for seamless handover of subscribers from LTE to Wi-Fi (S2bGTP).	21.8
First introduced.	Pre 21.2

Feature Description

When handover is initiated from LTE to Wi-Fi, the Delete Bearer Request (DBR) is sent over the LTE tunnel immediately when the Create Session Response (CSR) is sent on the Wi-Fi tunnel. This causes some packet loss because of the IPSec tunnel establishment delay at the ePDG. To address the issue of packet loss, an enhancement is introduced, in Release 21.8, that holds both the tunnels (LTE and Wi-Fi) and sends the Delete Bearer Request on LTE tunnel only when uplink data is seen on the Wi-Fi tunnel or on expiry of the configured handover timer (when there is no uplink data), whichever is earlier. As long as the LTE tunnel is active, uplink and downlink data is exchanged on the LTE tunnel. When handover is complete, uplink and downlink data is exchanged on the Wi-Fi tunnel. This prevents packet loss.

With this enhancement, the following benefits can be seen:

- Minimum packet loss during LTE to Wi-Fi (S2bGTP) handover and making the handover seamless (that is, MAKE before BREAK).
- LTE procedures are handled gracefully over the LTE tunnel when both tunnels are established with the P-GW.
- Wi-Fi procedures are handled gracefully over the Wi-Fi tunnel when both tunnels are established with the P-GW.
- When there are two tunnels (LTE and Wi-Fi) established for the same subscriber, GTP-U error indication and GTP-U path failure on the LTE or Wi-Fi tunnel (default or dedicated bearer) are handled properly during the transition period.

How It Works

The LTE to Wi-Fi (S2bGTP) Seamless Handover works as explained in the following sections.

LTE to Wi-Fi Handoff

The LTE to Wi-Fi handoff occurs as follows:

1. The P-GW delays sending the DBR to the S-GW until:

- CSR expiry is sent to the ePDG (default behavior).
 - Uplink data is sent on the Wi-Fi tunnel.
 - Handover timer has expired. If timer expires, the ePDG does not send the Modify Bearer Request (MBR) to notify handoff completion.
2. After CSR for LTE to Wi-Fi handoff is received, Control Plane GTPv2 (GTP-C) messages from LTE access are not handled at the P-GW. These messages are blocked at the EGTPC.
 3. LTE tunnel carries GTP-U traffic during the transition period. Transition period is defined as time between CSR (for LTE to Wi-Fi handoff is received) and handover completion. MBR for handoff completion is not expected in this scenario.
 4. In case of multiple outstanding CCR-Us being supported, all requests before the handoff request are dropped. This is done at IMSA.
 5. During the transition period:
 - If Modify Bearer Command (MBC) is received in Wi-Fi, it is rejected with Service-Denied message.
 - If Delete Bearer Command for dedicated bearer is received in LTE, it is discarded.
 - If PCRF sends RAR for policy change, it is processed after handover is complete.
 - New tunnel (that is, Wi-Fi) does not carry any GTP-U traffic. Any GTP-U traffic that is received on the Wi-Fi during the transition period is dropped or ignored. Similarly, any downlink traffic that is received on the Wi-Fi is sent on an older tunnel (that is, LTE tunnel) until DBR is sent on the Wi-Fi tunnel. This is true even when CSR is sent on the Wi-Fi tunnel. Any uplink traffic that is received on the Wi-Fi tunnel before timer expiry triggers the handover completion, and from then on all traffic is forwarded only through the Wi-Fi tunnel.
 - Any pending transactions on LTE access are discarded. For example, if CBR or UBR is sent for LTE access and handoff is initiated before completion of CBR or UBR transaction, then CBR or UBR is ignored at the P-GW. PCRF is not notified about failure.
 - If ASR is received, then call drop occurs and both tunnels go down.
 - If session-release occurs from PCRF, then call is dropped and CSR is sent with cause as “no-resources”.
 - GTP-U or GTP-C path failure over LTE leads to call drop for LTE access while the Wi-Fi call continues.
 - GTP-U or GTP-C path failure over Wi-Fi leads to call drop. Both tunnels are cleared.
 - If the user moves back to LTE (that is, back to back handoff from LTE to Wi-Fi to LTE) with HO-Ind set to 1 (after guard timer), then the HO is processed successfully and user session is moved to LTE again.
 - If the user moves back to LTE (that is, back to back handoff from LTE to Wi-Fi to LTE) with HO-Ind set to 0, then it leads to context replacement. Old call is cleared on Wi-Fi access with reason as context replacement and call is processed like a new call over LTE.

Session Recovery and ICSR

During the transition period, old access is considered as stable state and Full Checkpoint is triggered once handover is complete from LTE to Wi-Fi (S2bGTP). This is done for both Session Recovery and ICSR.

Configuring LTE to Wi-Fi Seamless Handover

The following section provides information about the CLI commands available to enable or disable the feature.

Configuring LTE to Wi-Fi Handover Timer

Use the following CLI commands to configure LTE to Wi-Fi handover timer.

```
configure
context context_name
  apn apn_name
    lte-s2bgtf-first-uplink timeout
    { default | no } lte-s2bgtf-first-uplink
  end
```

NOTES:

- **default:** Enables the LTE to Wi-Fi handover completion to occur when the Create Session Response is sent on the Wi-Fi tunnel.
- **no:** Disables the feature and handover completion occurs on Create Session Response.
- **lte-s2bgtf-first-uplink timeout:** Configures LTE to S2bGTP handover completion timeout in multiples of 100 milliseconds. The valid range is from 100 to 3000. The recommended configuration is 1000 milliseconds.
- By default, the LTE to Wi-Fi handover completion happens when Create Session Response is sent on the Wi-Fi tunnel. However, after handover timeout is configured, the handover is delayed until timeout or on receipt of uplink data on the Wi-Fi tunnel.

Monitoring and Troubleshooting

This section provides information regarding CLI commands available in support of monitoring and troubleshooting the feature.

Show Command(s) and/or Outputs

This section provides information regarding show commands and/or their outputs in support of this feature.

show apn statistics name <name>

The output of this CLI command has been enhanced to display the following new fields for the APN:

- LTE-to-S2bGTP handover Succeeded on First Uplink Data on S2b tunnel – Specifies the number of handovers due to uplink packets.

- LTE-to-S2bGTP handover Succeeded on Timer Expiry – Specifies the number of handovers due to timer expiry.

NOTES:

The new fields, introduced as part of this feature, are also displayed for the following CLI commands:

- **show pgw-service statistics name *service_name* verbose**
- **show pgw-service statistics all verbose**
- **show saegw-service statistics all function pgw verbose**

Bulk Statistics

The following statistics are included in support of this feature.

APN Schema

The following bulk statistics are added for APN in the APN schema in support of the LTE to Wi-Fi Seamless Handover feature.

Bulk Statistics	Description
apn-handoverstat-ltetos2bgtpsucc-timerexpiry	Number of LTE to S2bGTP handover succeeded on Timer Expiry.
apn-handoverstat-ltetos2bgtpsucc-uplnkdata	Number of LTE to S2bGTP handover succeeded on Uplink Data on the S2b tunnel.

P-GW Schema

The following bulk statistics are added for P-GW in the P-GW schema in support of the LTE to Wi-Fi Seamless Handover feature.

Bulk Statistics	Description
handoverstat-ltetos2bgtpsucc-timerexpiry	Handover Statistics - Number of LTE to GTP S2b successful handovers on Timer Expiry.
handoverstat-ltetos2bgtpsucc-uplnkdata	Handover Statistics - Number of LTE to GTP S2b successful handovers on Uplink Data on S2b tunnel.

SAEGW Schema

The following bulk statistics are added for SAEGW in the SAEGW schema in support of the LTE to Wi-Fi Seamless Handover feature.

Bulk Statistics	Description
pgw-handoverstat-ltetos2bgtpsucc-timerexpiry	P-GW Handover Statistics - Number of LTE to GTP S2b successful handover on Timer Expiry.

Bulk Statistics	Description
pgw-handoverstat-ltetos2bgtpsucc-uplnkdata	P-GW Handover Statistics - Number of LTE to GTP S2b successful handover on Uplink Data on S2b tunnel.



CHAPTER 33

LTE-M RAT Type Support on SAEGW, P-GW, and S-GW Services

- [Feature Summary and Revision History, on page 749](#)
- [Feature Description, on page 750](#)
- [How it Works, on page 751](#)
- [Configuring Virtual-APN, on page 753](#)
- [Configuring qci-qos-mapping, on page 753](#)
- [Monitoring and Troubleshooting, on page 754](#)

Feature Summary and Revision History

Summary Data

Applicable Product(s) or Functional Area	<ul style="list-style-type: none"> • S-GW • P-GW • SAEGW
Applicable Platform(s)	<ul style="list-style-type: none"> • ASR 5500 • VPC-DI • VPC-SI
Default Setting	Enabled-Always-On
Related Changes in This Release	Not Applicable
Related Documentation	<ul style="list-style-type: none"> • <i>Command Line Interface Reference</i> • <i>P-GW Administration Guide</i> • <i>S-GW Administration Guide</i> • <i>SAEGW Administration Guide</i>

Revision History

Revision Details	Release
First introduced.	21.24

Feature Description

LTE-M (LTE-MTC low-power-wide area (LPWA)) is a new cellular radio access technology specified by 3GPP that addresses low power-wide area connectivity solutions. It specifically refers to a specific category of LTE UEs that are suitable for IoT LTE-M, which supports IoT through lower device complexity and provides extended coverage, while allowing the reuse of the LTE installed base.

The RAT type IE is present in various call flows across many interfaces. When a Create Session Request is received with an unknown RAT Type, as the RAT Type is a Mandatory IE in this message, S-GW or P-GW may reject a create session request. In this StarOS 21.24 release, LTE-M RAT (Radio Access Technology) type for S-GW, P-GW, and SAEGW products are supported.

The RAT type is present either as an IE (for example, in GTPv2-C, GTPP), AVP (on Diameter-based interfaces) or as an attribute (for example in EDRs) across many interfaces.

The LTE-M solution for S-GW, P-GW, and SAEGW supports the following new LTE-M RAT type attribute value in the following Interfaces protocols and dictionaries:

- GX-interface: Diameter Protocol
- GY-interface: Diameter Protocol
- GZ/RF- interface: GTPP/Diameter/Radius
- S6B- Interface: Diameter Protocol
- S11/ S5/S8-Interface: GTPv2-C
- Dictionaries Radius AVPs, and dictionaries.
- Rf interface for CDR generation
- Attributes in EDRs

Enhancements to the Existing Features

The following existing features are enhanced to support the new RAT-TYPE LTE-M.

- **Virtual APN Selection Based on RAT Type:** Virtual APNs allow differentiated services within a single APN. The Virtual APN feature allows a carrier to use a single APN to configure differentiated services. The APN that is supplied by the MME is evaluated by the P-GW with multiple configurable parameters. Then, the P-GW selects an APN configuration based on the supplied APN and those configurable parameters. APN configuration dictates all aspects of a session at the P-GW, where different policies imply different APNs.

You can select the virtual APN by configuring directly under the base APN. This APN selection is done based on RAT Types. In this release, support is added through CLI to select the virtual APN for the LTE-M RAT type.

- **Qci and Qos Mapping:** P-GW supports QCI and QoS mapping association with APN based on RAT type LTE-M. This QCI and QoS mapping allow you to perform quick actions on the QoS Class Index (QCI) to QoS Mapping Configuration Mode, which is used to map QoS Class Indexes to enforceable QoS parameters. Mapping can occur in Serving Gateway (S-GW), and/or the PDN Gateway (P-GW) in an LTE network.
- **PCRF-based Handling:** P-GW informs the RAT type changes to PCRF through Credit Control Request -Initial and Updated messages, and PCRF provides a new PCC rule. Allows you to create a Bearer by enforcing a new Policy and Charging Control (PCC) rule from Policy and Charging Rules Function (PCRF).

How it Works

Architecture

The following table specifies the field and its value for various interfaces with support of LTE-M RAT type. Only Standard dictionaries and customized dictionaries are modified.

Table 68:

Field	Product	Messages	Permissions
P-GW Product			
x	RAT-Type (1032) Diameter	M-E T (7001)	Credit Control Request-Initial • Credit Control Request - Updated
y	3GPP-RAT-Type (21M) Diameter	M-E T (9)	Credit Control Request-Initial • Credit Control Request - Updated
SUBCD	RRAT-Type (21M)	M-E T (9)	Accounting Request -Start • Accounting Request- Stop • Account request -Interim
f	3GPP-RRAT-Type (21M) Diameter	M-E T (9)	Accounting Request -Start • Accounting Request- Stop • Account request -Interim
b	3GPP-RRAT-Type (1032) Diameter	M-E T (9)	Authentication • Authorisation • Request

ca	File	P	Messages
		et	rt
			A
s	RAT-Type	M	ETL) 9 (
W S	RAT-Type (30) R.D.C GTP	M	ETL) 9 (<ul style="list-style-type: none"> Gtpp Data Record Transfer Request
S-GW Product			
s	RAT-Type (30)	M	ETL) 9 (<ul style="list-style-type: none"> Gtpp Data Record Transfer Request

Limitations

Following are the known limitations for new LTE-M RAT type feature:

- Rule matching at ECS
- Ruledef matching at Local-Policy

Supported Standards

Cisco's implementation of the LTE RAT type complies with the following standards:

- 3GPP 23.401 – eGTPC Interface
- 3GPP 29.274 Release 15.4.0 – 3GPP GTPv2 Protocol Specification Reference table for LTE-M Rat type support; RAT Type IE details are given in the following table for egtpc IEs encoding and decoding :
 - Table 7.2.1-1: Information Elements in a Create Session Request
 - Table 7.2.7-1: Information Elements in a Modify Bearer Request
 - Table 7.2.7-1: Information Elements in a Modify Bearer Request
- 3GPP 23.401 Release 15.4.0 – 3rd Generation Partnership Project; Technical Specification Group Services and System Aspects; General Packet Radio Service (GPRS) enhancements for Evolved Universal Terrestrial Radio Access Network (E-UTRAN) access
- 3GPP 32.299 Release 15.4.0 – 3rd Generation Partnership Project; Technical Specification Group Core Network and Terminals; Policy and Charging Control (PCC).
- 3GPP 29.060 – 3rd Generation Partnership Project; Technical Specification Group Core Network and Terminals; General Packet Radio Service (GPRS); GPRS Tunnelling Protocol (GTP) across the Gn and Gp interface.
- 3GPP 29.061 – 3rd Generation Partnership Project; Technical Specification Group Core Network and Terminals; Interworking between the Public Land Mobile Network (PLMN) supporting packet based services and Packet Data Networks (PDN)

- 3GPP 32.298 – 3rd Generation Partnership Project; Technical Specification Group Services and System Aspects; Telecommunication management; Charging management; Charging Data Record (CDR) parameter description
- 3GPP 29.212 Release 15.4.0 – 3rd Generation Partnership Project; Technical Specification Group Core Network and Terminals; Policy and Charging Control (PCC).

Configuring Virtual-APN

Use the following configuration to display an additional option (LTE-M) “RAT-Type” based Virtual-APN selection .

```
configure
  context context_name
  apn apn_name
    virtual-apn preference value apn apn_name rat-type lte-m
  end
```

NOTES:

- **apn apn_name**: Allows to specify the APN name as a condition. *apn_name* must be an alphanumeric string of 1 through 63 characters.
- **virtual-apn preference value apn apn_name** : Configures the virtual-apn (virtual.ipv4).
- **rat-type lte-m**: Enables LTE-M as an additional RAT-type.

Configuring qci-qos-mapping

Use the following configuration to configure QCI-QOS mapping in the APN Configuration mode and associate additional RAT type (LTE-M).

```
configure
  context context_name
  apn apn_name
    qci table
      qci-qos-mapping
        qci qci_val non-gbr { downlink user-datagram dscp-marking value
        }
      end
    end
```

NOTES:

- **apn apn_name**: Allows to specify the APN name as a condition. *apn_name* must be an alphanumeric string of 1 through 63 characters.
- **qci-qos-mapping**: Configures the qci-qos-mapping for APN.
- **qci qci_val**: Specifies the QoS Class Identifier. *qci_val* must be an integer between 1 to 9, 80, 82, and 83.
 - **downlink**: Specifies the direction of traffic on which this QoS configuration needs to be applied.

Associate Qci-Qos-Mapping

Use the configuration to select the qci-qos-mapping RAT Type.

```

configure
  context context_name
    apn apn_name
      associate qci-qos-mapping table rat-type lte-m
    end

```

NOTES:

- **associate qci-qos-mapping table rat-type lte-m** : Associates apn qci-qos-mapping based on the RAT type.

Monitoring and Troubleshooting

This section provides information regarding commands available to monitor and troubleshoot the LTE-M RAT Type support on the SAEGW, P-GW and S-GW Services.

Show Commands and Output

This section provides information on show commands and their corresponding outputs for the LTE-M RAT type feature.

show apn name

The following output is displayed if the Virtual-APN is selected based on the RAT-Type, during the Session-Setup.

Output:

```

show apn name <>
Virtual APN Configuration:
  Preference  Selected-APN          Rule-Definition
  10          verizon.ipv4          CC Profile Index = 3
  RAT Type = lte-m [local]qvpc-si# show configuration

```

show apn all

The output of **show apn all** and **show apn name apn_name all** commands has been enhanced to monitor the APN configuration for qci-qos-mapping on RAT type **lte-m**:

Example:

```

show apn name <>
qci-qos-mapping Name for RAT-Type:
GERAN :N/A          UTRAN :N/A
EUTRAN : N/A        LTE-M : table
Stats Profile Name : N/A

```

show qci-qos-mapping table all

Following example is the sample output before associating the qci-qos-mapping table based on additional RAT Type (LTE-M).

```

QCI-QOS Table Name: table

Qci: 1
uplink: n/a
downlink: user-datagram          dscp-marking 0x3e
maximum packet delay: n/a        maximum error rate: n/a
delay class: n/a                  precedence class: n/a
reliability class: n/a           qci type: non-gbr
volte: n/a                        traffic policing interval: n/a

Qci: 2
uplink: n/a
downlink: internal-qos priority 1
maximum packet delay: n/a        maximum error rate: n/a
delay class: n/a                  precedence class: n/a
reliability class: n/a           qci type: gbr
volte: n/a                        traffic policing interval: n/a

```

show configuration

The **virtual-apn preference** *value apn apn_name rat-type lte-m* output is displayed when the Virtual APN is configured with the LTE-M RAT type. Following is the sample output:

```

[local]qvpc-si# show configuration
apn intershat
  pdp-type ipv4 ipv6
  bearer-control-mode mixed
  selection-mode subscribed sent-by-ms chosen-by-sgsn
  accounting-mode radius
  ims-auth-service ims-ggsn-auth
  ip access-group acl4-1 in
  ip access-group acl4-1 out
  authentication pap 1 chap 2 allow-noauth
  ip context-name egress
  virtual-apn preference 10 apn verizon.ipv4 rat-type lte-m
  ipv6 access-group acl6-1 in
  ipv6 access-group acl6-1 out
  active-charging rulebase prepaid
exit

```

Similarly, the **associate qci-qos-mapping table rat-type lte-m** output is displayed for the qci-qos association changes based on RAT type. Following is the sample output

```

[local]laas-setup# show configuration
  apn intershat
  context ingress
  subscriber default
  nexthop-forwarding-address
  exit
  apn intershat
  associate qci-qos-mapping table rat-type lte-m
  exit

```

show subscribers full

The output of this show command is used for monitoring the subscriber call. The RAT type of the call is displayed as LTE-M. A new field **LTE-M** is added under Access Technology. Following is the sample output:

```

[local]laas-setup# show subscribers all
Access (X) - CDMA 1xRTT (E) - GPRS GERAN (I) - IP
|| Tech: (D) - CDMA EV-DO (U) - WCDMA UTRAN (W) - Wireless LAN
|| (A) - CDMA EV-DO REVA (G) - GPRS Other (M) - WiMax

```

show subscribers full all

```

||                (C) - CDMA Other          (J) - GAN          (O) - Femto IPsec
||                (P) - PDIF                (S) - HSPA        (L) - eHRPD
||                (T) - eUTRAN              (B) - PPPoE       (F) - FEMTO UTRAN
||                (N) - NB-IoT              (Q) - WSG         (R) - LTE-M
||                (.) - Other/Unknown

```

show subscribers full all

The output of the following show commands are used for monitoring the subscriber call. The Access Technology of the call is displayed as LTE-M.

```

Username: 9890098900          Status: Online/Active
Access Type: sgw-pdn-type-ipv4-ipv6   Network Type: IPV4+IPV6
Access Tech: LTE-M             Access Network Peer ID: n/a
callid: 02fb3ea1              msid: 404005123456789
Card/Cpu: 1/0                 Sessmgr Instance: 11
state: Connected
connect time: Tue Mar 23 04:33:55 2021 call duration: 00h00m46s
idle time: 00h00m40s          idle time left: n/a

```

show subs pgw-only full / show subs pgw-only full all

The **show subs pgw-only full / show subs pgw-only full all** commands display the Access Technology of the call as LTE-M. Following is the sample output:

```

Access Type: gtp-pdn-type-ipv4-ipv6   Network Type: IPV4+IPV6
Access Tech: LTE-M                    pgw-service-name: PGW21
Callid: 02fb3ea2                     IMSI: 404005123456789
MSISDN: 9890098900                   External ID: n/a
Interface Type: S5S8GTP               Low Access Priority: N/A
TWAN Mode: N/A
eMPS Bearer: No
Emergency Bearer Type: N/A
IMS-media Bearer: No
S6b Auth Status: N/A

```

show subs sgw-only full / show subs sgw-only full all

The **show subs sgw-only full / show subs sgw-only full all** commands display the Access Technology of the call as LTE-M. Following is the sample output:

```

Card/Cpu          : 1/0          Sessmgr Instance : 11
Idle time         : 00h05m47s
MS TimeZone       : n/a          Daylight Saving Time: n/a

Access Type: sgw-pdn-type-ipv4-ipv6   Network Type: IPV4+IPV6
Access Tech: LTE-M                     sgw-service-name: SGW21
Callid: 02fb3ea1                       IMSI: 404005123456789
MSISDN: 9890098900
eMPS Bearer: No

```

show subs saegw-only full / show subs saegw-only full all

The **show subs saegw-only full / show subs saegw-only full all** commands display the Access Technology of the call as LTE-M. Following is the sample output:

```

Callid   : 02fb3ea3          IMSI           : 404005123456789
Card/Cpu : 1/0              Sessmgr Instance : 11
Source context : EPC2       Destination context : ISP1
Bearer Type  : Default      Bearer-Id       : 5
Access Type  : gtp-pdn-type-ipv4-ipv6   Network Type     : IPV4+IPV6

```

```

Access Tech      : LTE-M                      saegw-service-name : SAEGW21
MSISDN          : 9890098900                 External ID        : n/a
TWAN Mode       : N/A
eMPS Bearer     : No
WPS Bearer      : No

```

show subs pgw-only all

The **show subs pgw-only all** command displays the following output:

```

|+-----Access      (U) - UTRAN      (G) - GERAN
||      Tech:      (W) - WLAN              (J) - GAN
||              (U) - HSPA Evolution    (E) - eUTRAN
||              (H) - eHRPD             (.) - Unknown
||              (N) - NB-IoT           (R) - LTE-M

```

show subs sgw-only all

The **show subs sgw-only all** command displays the following output:

```

|+----Access      (U) - UTRAN  (G) - GERAN              (W) - WLAN
||      Tech:      (J) - GAN          (S) - HSPA Evolution (E) - eUTRAN
||              (.) - Unknown        (N) - NB-IoT         (R) - LTE-M
||

```

show subs saegw-only all

The **show subs saegw-only all** command displays the following output:

```

|+----Access      (U) - UTRAN  (G) - GERAN              (W) - WLAN
||      Tech:      (J) - GAN          (S) - HSPA Evolution (E) - eUTRAN
||              (H) - eHRPD          (.) - Unknown        (N) - NB-IoT
||              (R) - LTE-M

```

show subscribers callid

The **show subscribers callid** *callid* command displays the Access Technology of the call as LTE-M. Following is the sample output:

```

|+----Access      (X) - CDMA 1xRTT (E) - GPRS GERAN      (I) - IP
||      Tech:      (D) - CDMA EV-DO          (U) - WCDMA UTRAN    (W) - Wireless LAN
||              (A) - CDMA EV-DO REVA      (G) - GPRS Other    (M) - WiMax
||              (C) - CDMA Other           (J) - GAN           (O) - Femto IPsec
||              (P) - PDIF                 (S) - HSPA         (L) - eHRPD
||              (T) - eUTRAN               (B) - PPPoE        (F) - FEMTO UTRAN
||              (N) - NB-IoT               (Q) - WSG          (R) - LTE-M
||
||              (.) - Other/Unknown

```

show session subsystem

The following output displays the session related statistics:

```

LTE-M Data Statistics
    0 Total Sessions                0 Total calls arrived
    0 Total calls connected          0 Total calls disconnected
NB-IoT Connection Statistics
    0 Total Sessions                0 Total calls arrived
    0 Total calls connected          0 Total calls disconnected
LTE-M Connection Statistics

```

show session subsystem verbose

```

0 Total Sessions                0 Total calls arrived
0 Total calls connected         0 Total calls disconnected

```

Similarly, the **show session subsystem full** is enhanced to display the Data packets and subscribers count per RAT type.

show session subsystem verbose

The **show session subsystem verbose** command displays the following output:

```

NB-IoT Data Statistics
    packets to User:          0    octets to User:    0
    packets from User:        0    octets from User:  0

LTE-M Data Statistics
    packets to User:          0    octets to User:    0
    packets from User:        0    octets from User:  0

NB-IoT Connection Statistics
0 Total Sessions                0 Total calls arrived
0 Total calls connected         0 Total calls disconnected

LTE-M Connection Statistics
0 Total Sessions                0 Total calls arrived
0 Total calls connected         0 Total calls disconnected

```

show session summary

The **show session summary** command displays the following output:

```

4G LTE (EUTRAN): 0
2G (GERAN): 0
3G (UTRAN): 0
WiFi (WIRELSS LAN): 0
eHRPD: 0
3G HA: 0
NB-IoT: 2
LTE-M: 0
Others: 0

```

show subscribers subscription full

The **show subscribers subscription full** command displays the following output:

```

Username: 9890098900          Status: Online/Active
Access Type: sgw-pdn-type-ipv4-ipv6    Network Type: IPV4+IPV6
Access Tech: LTE-M              Access Network Peer ID: n/a
callid: 02fb3ea1                msid: 404005123456789
Card/Cpu: 1/0                    Sessmgr Instance: 11
state: Connected
connect time: Wed Mar 17 09:59:47 2021 call duration: 00h01m19s
idle time: 00h01m13s             idle time left: n/a
session time left: n/a

```

show subscribers activity all

The **show subscribers activity all** command displays the Access Technology of the call as LTE-M. Following is the sample output:

```

Username: 9890098900          Status: Online/Active
Access Type: sgw-pdn-type-ipv4-ipv6    Network Type: IPV4+IPV6

```

```
Access Tech: LTE-M
callid: 02fb3eal
```

```
Access Network Peer ID: n/a
msid: 404005123456789
```

show apn statistics all-name

The show output command displays the statistics per APN and also displays number of initiated sessions and active sessions with LTE-M RAT Type per APN. Following is the sample output:

```
Initiated Sessions per RAT Type:
  EUTRAN: 0    UTRAN: 0
  GERAN: 0    EHRPD: 0
  S2A GTP: 0   S2B GTP: 0
  S2B PMIP:0   NB-IoT: 0
  LTE-M : 0
```

```
Active Sessions per RAT Type:
  EUTRAN: 0   UTRAN: 0
  GERAN: 0   WLAN: 0
  HSPA: 0    NB-IoT:0
  LTE-M: 0   OTHER: 0
```

show saegw-service statistics all-name

The show output command displays the statistics per SAEGW service and also displays Current subscribers, the Current PDNs with NB-IoT RAT Type per SAEGW Service. Following is the sample output:

```
Current Subscribers By RAT-Type:
  EUTRAN: 0    UTRAN: 0
  GERAN: 0    NB-IoT: 0
  LTE-M: 0    OTHER: 0

Current PDNs By RAT-Type:
  EUTRAN: 0    UTRAN: 0
  GERAN: 0    NB-IoT: 0
  LTE-M: 0    OTHER: 0
```

show pgw-service statistics all-name

The show output command displays statistics for each P-GW Services, the number of initiated PDNs, and current PDNs with NB-IoT RAT Type for each P-GW Services. Following is the sample output:

```
Initiated PDNs By RAT-Type:
  EUTRAN: 0    UTRAN: 0
  GERAN: 0    EHRPD: 0
  S2A GTP: 0   S2B GTP: 0
  S2B PMIP: 0   NB-IoT: 0
  LTE-M      0

Current PDNs By RAT-Type:
  EUTRAN: 0    UTRAN: 0
  GERAN: 0    WLAN: 0
  NB-IoT: 0    LTE-M: 0
  OTHER: 0
```

show sgw-service statistics

This show command displays statistics for each S-GW Services. This CLI is enhanced to display Current Subscribers and Current PDNs with NB-IoT RAT type for each S-GW Services. Following is the sample output:

```

Current Subscribers By RAT-Type:
  EUTRAN: 0      UTRAN: 0
  GERAN:  0      NB-IoT: 0
  LTE-M:  0      OTHER: 0
Current PDNs By RAT-Type:
  EUTRAN: 0      UTRAN: 0
  GERAN:  0      NB-IoT: 0
  LTE-M:  0      OTHER: 0

```

Bulk Statistics

The following statistics are added in support of the LTE-M RAT type feature

APN Schema

The following LTE-M RAT type feature-related bulk statistics are available in the APN schema.

Bulk Statistics	Description
active-lte-m-sessions	The total number of active LTE-M sessions per APN with RAT type LTE-M.
initiated-lte-m-sessions	The total number of initiated LTE-M sessions.

P-GW Schema

The following LTE-M RAT type feature related bulk statistics available in the P-GW schema.

Bulk Statistics	Description
sesstat-pdn-rat-lte-m	The total number of active PDN Type Statistics – LTE-M.
sessstat-rat-init-lte-m	The total number of initiated LTE-M PDNs (with RAT Type LTE-M).

S-GW Schema

The following LTE-M RAT type feature related bulk statistics available in the S-GW schema.

Bulk Statistics	Description
sessstat-totcur-ue-lte-m	The total number of active UEs with LTE-M RAT type.
sessstat-totcur-pdn-lte-m	The total number of active PDNs with LTE-M RAT type.

SAEGW Schema

The following LTE-M RAT type feature related bulk statistics available in the SAE-GW schema.

Bulk Statistics	Description
sgw-sessstat-totcur-ue-lte-m	The total number of active UEs with LTE-M RAT type.
sgw-sessstat-totcur-pdn-lte-m	The total number of LTE-M PDNs (PGW anchored/Collapsed PDN) with RAT Type LTE-M.
pgw-sesstat-pdn-rat-lte-m	The total number of LTE-M PDNs (PGW anchored/Collapsed PDN) with RAT Type LTE-M.
pgw-sessstat-pdn-rat-init-lte-m	The total number of initiated LTE-M PDNs.
saegw-sgw-anchor-pdn-rat-lte-m	The total number of LTE-M PDNs (SGW anchored) with RAT Type LTE-M.
saegw-pgw-anchor-pdn-rat-lte-sm	The total number of LTE-M PDNs (PGW anchored) with RAT Type LTE-M.
saegw-collapsed-pdn-rat-lte-m	The total number of LTE-M PDNs (PGW anchored/Collapsed PDN) with RAT Type LTE-M.



CHAPTER 34

Maximum Receive Unit Configuration Support

- [Feature Summary and Revision History, on page 763](#)
- [Feature Description, on page 764](#)
- [How It Works, on page 764](#)
- [Configuring the MRU Feature, on page 764](#)

Feature Summary and Revision History

Summary Data

Applicable Product(s) or Functional Area	<ul style="list-style-type: none"> • P-GW • SAE-GW • S-GW
Applicable Platform(s)	ASR 5500
Feature Default	Disabled - Configuration Required
Related Changes in This Release	Not Applicable
Related Documentation	<ul style="list-style-type: none"> • <i>Command Line Interface Reference</i> • <i>P-GW Administration Guide</i> • <i>SAEGW Administration Guide</i> • <i>S-GW Administration Guide</i>

Revision History

Revision Details	Release
First introduced.	21.24

Feature Description

Prior to MRU Configuration support, the Maximum Receive Unit (MRU) setting was equal to the Maximum Transmission Unit (MTU).

When the MTU of eNB on the S1-U interface was increased to 2000 bytes but no changes were made on the MTU on S1-U interface on SAE-GW, packets were received at SAE-GW with size more than 1500 bytes. This resulted into those packets getting dropped at the S1-U interface on the SAE-GW with **Lport_MRU_exceeded** exception. This was affecting UEs that were trying to set up IKE Tunnels.

This Configure MRU feature allows you to configure MRU separately from MTU.

How It Works

To handle MRU independently of MTU, changes are made in Network Processing Unit (NPU), NPUSIM, NPUMGR, and CLI.

Configuring the MRU Feature

This section describes how to configure the MRU of the IP interface along with MTU using the **ip mtu** keyword under interface configuration.

Configuring MRU

To configure the MTU and MRU in the Ethernet Interface Configuration mode, use the following sample configuration.

```
config
  context context_name
    interface interface_name broadcast
      ip mtu mtu_size [ mru mru_size ]
    end
```

NOTES:

- **ip mtu mtu_size**: Specify the MTU size. *mtu_size* must be an integer in the range of 5762048 bytes.
- **mru mru_size**: Specify the MRU size. *mru_size* must be an integer in the range of 5762048 bytes.
- Use the **no ip mtu** command to disable the MTU configuration.
- The maximum configurable value for MTU is 2048 bytes.. If MTU is not configured, the default value is 1500 bytes.
- MRU attribute is optional and when it is not configured, MRU is set to the same value as MTU.
- MRU optional attribute is not applicable to VPC-DI and VPC-SI platforms. This attribute is only visible on ASR 5500.
- On CUPS or ICUPS, the following error is displayed you when you try to configure MRU on an interface.

Failure: Configure MRU Feature is not supported when ICUPS/CUPS is enabled!

- Although the product allows configuring asymmetric MTU and MRU values on the same interface is not advised as it may result into undesirable behavior on the network.

Configuring the MRU Feature when no MTU is specified

MTU = default MTU, MRU = default MTU

For example:

```
configure
  interface SGi-VLAN400
    logical-port-statistics
    ip address 172.26.96.3 255.255.255.248
    ipv6 address 2600:300:2030:1104::3/64 secondary
    bfd interval 300 min_rx 300 multiplier 3
  #exit
#exit
```

Configuring the MTU Feature when no MRU is specified

MRU = Configured MTU for backward compatibility. MRU = MTU = 1970 bytes.

For example:

```
configure
  interface SGi-VLAN400
    logical-port-statistics
    ip address 172.26.96.3 255.255.255.248
    ipv6 address 2600:300:2030:1104::3/64 secondary
    ip mtu 1970
    bfd interval 300 min_rx 300 multiplier 3
  #exit
```

Configuring the MTU Feature when both MTU and MRU are specified

MTU = default MTU, MRU = default MTU

For example:

```
configure
  interface SGi-VLAN400
    logical-port-statistics
    ip address 172.26.96.3 255.255.255.248
    ipv6 address 2600:300:2030:1104::3/64 secondary
    ip mtu 1600 mru 1700
    bfd interval 300 min_rx 300 multiplier 3
  #exit
```

Verifying the Configured MRU

The output of the is enhanced to display the configured MRU value.

For example:

```
[EPC2]26k1-chassis# config
[EPC2]26k1-chassis(config)# context EPC2
[EPC2]26k1-chassis(config-ctx)# interface TO-EPC2-SGW-INGRESS
[EPC2]26k1-chassis(config-if-eth)# ip mtu 1500 mru 1970
```

```
[EPC2]26kl-chassis(config-if-eth)# end
[EPC2]26kl-chassis# show ipv6 interface
Intf Name: TO-EPC1-SGW-INGRESS
Intf Type: Broadcast
Description:
VRF: None
IP State: UP (Bound to 5/20 vlan id 190, 802.1P prior 0, ifIndex 85196802)
Router Advertisement: disabled MTU: 1500 MRU: 1970
IPv6 Link-Local Address: fe80::d272:dcff:fea3:8543/64
IPv6 Global Unicast Address: 2001::1:21/64
L3 monitor LC-port switchover: Disabled
Number of Secondary Addresses: 5
IPv6 Address: 2001::1:31/64
IPv6 Address: 2001::1:205/64
IP Address: 10.10.10.21 Subnet Mask: 255.255.255.0
IP Address: 10.10.10.31 Subnet Mask: 255.255.255.0
IP Address: 10.10.10.200 Subnet Mask: 255.255.255.0
```

NOTES:

- Use the **show ipv6 interface** command to verify if the Configurable MTU configuration is enabled or disabled.
- **no ip mtu**: Disables the Configurable MTU configuration.



CHAPTER 35

Mobile IP Registration Revocation

This chapter describes Registration Revocation for Mobile-IP and Proxy Mobile-IP and explains how it is configured. The product administration guides provide examples and procedures for configuration of basic services on the system. It is recommended that you select the configuration example that best meets your service model and configure the required elements for that model, as described in this administration guide before using the procedures in this chapter.



Important This license is enabled by default; however, not all features are supported on all platforms and other licenses may be required for full functionality as described in this chapter.

This chapter includes the following topics:

- [Overview, on page 767](#)
- [Configuring Registration Revocation, on page 768](#)

Overview

Registration Revocation is a general mechanism whereby either the HA or the FA providing Mobile IP functionality to the same mobile node can notify the other mobility agent of the termination of a binding. This functionality provides the following benefits:

- Timely release of Mobile IP resources at the FA and/or HA
- Accurate accounting
- Timely notification to mobile node of change in service

Mobile IP Registration Revocation can be triggered at the FA by any of the following:

- Session terminated with mobile node for whatever reason
- Session renegotiation
- Administrative clearing of calls
- Session Manager software task outage resulting in the loss of FA sessions (sessions that could not be recovered)



Important Registration Revocation functionality is also supported for Proxy Mobile IP. However, only the HA can initiate the revocation for Proxy-MIP calls.

Mobile IP Registration Revocation can be triggered at the HA by any of the following:

- Administrative clearing of calls
- Inter-Access Gateway handoff. This releases the binding at the previous access gateway/FA
- Session Manager software task outage resulting in the loss of FA sessions (for sessions that could not be recovered)
- Session Idle timer expiry (when configured to send Revocation)
- Any other condition under which a binding is terminated due to local policy (duplicate IMSI detected, duplicate home address requested, etc.)

The FA and the HA negotiate Registration Revocation support when establishing a Mobile IP call. Revocation support is indicated to the Mobile Node (MN) from the FA by setting the 'X' bit in the Agent Advertisement to MN. However the MN is not involved in negotiating the Revocation for a call or in the Revocation process. It only gets notified about it. The X bit in the Agent Advertisements is just a hint to the MN that revocation is supported at the FA but is not a guarantee that it can be negotiated with the HA

At the FA, if revocation is enabled and a FA-HA SPI is configured, the Revocation Support extension is appended to the RRQ received from the MN and protected by the FA-HA Authentication Extension. At the HA, if the RRQ is accepted, and the HA supports revocation, the HA responds with an RRP that includes the Revocation Support extension. Revocation support is considered to be negotiated for a binding when both sides have included a Revocation Support Extension during a successful registration exchange.



Important The Revocation Support Extension in the RRQ or RRP must be protected by the FA-HA Authentication Extension. Therefore, an FA-HA SPI must be configured at the FA and the HA for this to succeed.

If revocation is enabled at the FA, but an FA-HA SPI is not configured at the FA for a certain HA, then FA does not send Revocation Support Extension for a call to that HA. Therefore, the call may come up without Revocation support negotiated.

If the HA receives an RRQ with Revocation Support Extension, but not protected by FA-HA Auth Extension, it will be rejected with "FA Failed Authentication" error.

If the FA receives a RRP with Revocation Support Extension, but not protected by FA-HA Auth Extension, it will be rejected with "HA Failed Authentication" error.

Also note that Revocation support extension is included in the initial, renewal or handoff RRQ/RRP messages. The Revocation extension is not included in a Deregistration RRQ from the FA and the HA will ignore them in any Deregistration RRQs received.

Configuring Registration Revocation

Support for MIP Registration Revocation requires the following configurations:

- **FA service(s):** Registration Revocation must be enabled and operational parameters optionally configured.
- **HA service(s):** Registration Revocation must be enabled and operational parameters optionally configured.



Important These instructions assume that the system was previously configured to support subscriber data sessions for a core network service with FA and/or an HA according to the instructions described in the respective product Administration Guide.



Important Commands used in the configuration samples in this section provide base functionality to the extent that the most common or likely commands and/or keyword options are presented. In many cases, other optional commands and/or keyword options are available. Refer to the *Command Line Interface Reference* for complete information regarding all commands.

Configuring FA Services

Configure FA services to support MIP Registration Revocation by applying the following example configuration:

```
configure
  context <context_name>
    fa-service <fa_service_name>
      revocation enable
      revocation max-retransmission <number>
      revocation retransmission-timeout <time>
    end
```

Save your configuration to flash memory, an external memory device, and/or a network location using the Exec mode command **save configuration**. For additional information on how to verify and save configuration files, refer to the *System Administration Guide* and the *Command Line Interface Reference*.

Configuring HA Services

Configure HA services to support MIP Registration Revocation by applying the following example configuration:

```
configure
  context <context_name>
    ha-service <ha_service_name>
      revocation enable
      revocation max-retransmission <number>
      revocation retransmission-timeout <time>
    end
```

Save your configuration to flash memory, an external memory device, and/or a network location using the Exec mode command **save configuration**. For additional information on how to verify and save configuration files, refer to the *System Administration Guide* and the *Command Line Interface Reference*.



CHAPTER 36

Multi-Protocol Label Switching (MPLS) Support

This chapter describes the system's support for BGP/MPLS VPN and explains how it is configured. The product administration guides provide examples and procedures for configuration of basic services on specific systems. It is recommended that you select the configuration example that best meets your service model and configure the required elements for that model, as described in the respective product administration guide, before using the procedures in this chapter.

When enabled through a feature license key, the system supports MPLS to provide a VPN connectivity from the system to the corporate's network.



Important This release provides BGP/MPLS VPN for directly connected PE routers only.

MP-BGP is used to negotiate the routes and segregate the traffic for the VPNs. The network node learns the VPN routes from the connected Provider Edge (PE), while the PE populates its routing table with the routes provided by the network functions.

- [Overview, on page 771](#)
- [Supported Standards, on page 773](#)
- [Supported Networks and Platforms, on page 774](#)
- [Licenses, on page 774](#)
- [Benefits, on page 774](#)
- [Configuring BGP/MPLS VPN with Static Labels, on page 774](#)
- [Configuring BGP/MPLS VPN with Dynamic Labels, on page 777](#)

Overview

As seen in the following scenario, the chassis can be deployed as a router while supporting BGP/MPLS-VPN in a network.

- Chassis as MPLS-Customer Edge (MPLS-CE) connecting to Provider Edge (PE)
- Chassis as MPLS-Customer Edge (MPLS-CE) connecting to Autonomous System Border Router (ASBR)

Chassis as MPLS-CE Connecting to PE

Figure 121: Chassis as MPLS-CE Connected to PE

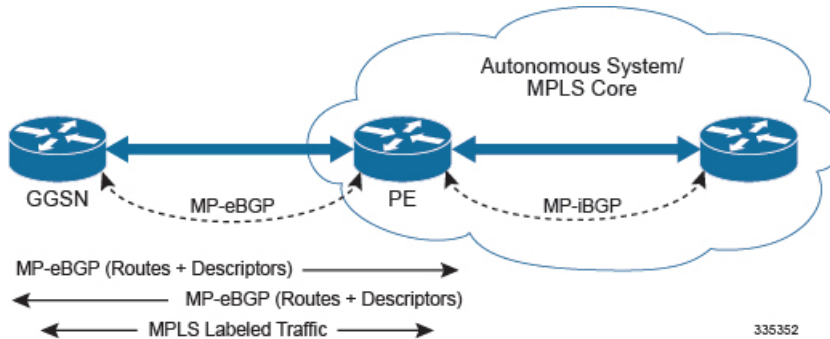

The system in this scenario uses static/dynamic MPLS labels for ingress and egress traffic. For configuration information on static label, refer to the [Configuring BGP/MPLS VPN with Static Labels, on page 774](#) section and refer to [Configuring BGP/MPLS VPN with Static Labels, on page 774](#) for dynamic label configuration.

The system is in a separate autonomous system (AS) from the Provider Edge (PE). It communicates with the PE and all VPN routes are exchanged over MP-BGP. Routes belonging to different VPNs are logically separated, using separate virtual route forwarding tables (VRFs).

Routes for each VPN are advertised as VPN-IPv4 routes, where route distinguishers are prepended to regular IPv4 routes to allow them to be unique within the routing table. Route targets added to the BGP extended community attributes identify different VPN address spaces. The particular upstream BGP peer routing domain (VPN), from which a route is to be imported by the downstream peer into an appropriate VRF, is identified with an extended community in the advertised NLRI.

A unique label is also received or advertised for every VPN route.

The Customer Edge (CE) also advertises routes to the PE using NRIs that include route distinguishers to differentiate VPNs, an extended community to identify VRFs, and a MPLS-label, which will later be used to forward data traffic.

There is a single MPLS-capable link between the CE and the PE. MP-BGP communicates across this link as a TCP session over IP. Data packets are sent bidirectionally as MPLS encapsulated packets.

This solution does not use any MPLS protocols. The MPLS label corresponding to the immediate upstream neighbor can be statically configured on the downstream router, and similarly in the reverse direction.

When forwarding subscriber packets in the upstream direction to the PE, the CE encapsulates packets with MPLS headers that identify the upstream VRF (the label sent with the NLRI) and the immediate next hop. When the PE receives a packet it swaps the label and forward.

The CE does not run any MPLS protocol (LDP or RSVP-TE).

When receiving data packets in the downstream direction from the PE, the label is checked to identify the destination VRF. Then the packet is de-encapsulated into an IP packet and sent to the session subsystem for processing.



Important MPLS ping/trace route debugging facilities are not supported.

Chassis as MPLS-CE Connected to ASBR

Figure 122: Chassis as MPLS-CE Connected to ASBR

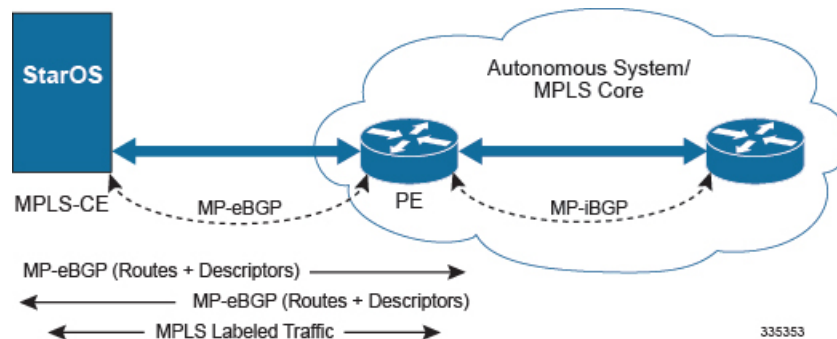

The system in this scenario uses static/dynamic MPLS labels for ingress and egress traffic. For configuration information on static label, refer to [Configuring BGP/MPLS VPN with Static Labels, on page 774](#) and refer to [Configuring BGP/MPLS VPN with Dynamic Labels, on page 777](#) for dynamic label configuration.

This scenario differs from the MPLS-CE with PE scenario in terms of peer functionality even though MPLS-CE functionality does not change. Like the MPLS-CE with PE scenario, MPLS-CE system maintains VRF routes in various VRFs and exchanges route information with peer over MP-eBGP session.

The peer in this scenario is not a PE router but an Autonomous System Border Router (ASBR). The ASBR does not need to maintain any VRF configuration. The PE routers use iBGP to redistribute labeled VPN-IPv4 routes either to an ASBR or to a route reflector (of which the ASBR is a client). The ASBR then uses the eBGP to redistribute those labeled VPN-IPv4 routes to an MPLS-CE in another AS. Because of the eBGP connection, the ASBR changes the next-hop and labels the routes learned from the iBGP peers before advertising to the MPLS-CE. The MPLS-CE is directly connected to the eBGP peering and uses only the MP-eBGP to advertise and learn routes. The MPLS-CE pushes/pops a single label to/from the ASBR, which is learned over the MP-eBGP connection. This scenario avoids the configuration of VRFs on the PE, which have already been configured on the MPLS-CE.

Engineering Rules

- Up to 5,000 "host routes" spread across multiple VRFs per BGP process. Limited to 6,000 pool routes per chassis.
- Up to 2,048 VRFs per chassis.

Supported Standards

Support for the following standards and requests for comments (RFCs) have been added with this interface support:

- RFC 4364, BGP/MPLS IP VPNs
- RFC 3032, MPLS Label Stack Encoding



Important One or more sections of above mentioned IETF are partially supported for this feature. For more information on Statement of Compliance, contact your Cisco account representative.

Supported Networks and Platforms

This feature supports all ASR5500 platforms with StarOS Release 9.0 or later running with network function services.

Licenses

Multi-protocol label switching (MPLS) is a licensed Cisco feature. A separate feature license may be required. Contact your Cisco account representative for detailed information on specific licensing requirements. For information on installing and verifying licenses, refer to the *Managing License Keys* section of the *Software Management Operations* chapter in the *System Administration Guide*.

Benefits

MPLS provides networks with a more efficient way to manage applications and move information between locations. MPLS prioritizes network traffic, so administrators can specify which applications should move across the network ahead of others.

Configuring BGP/MPLS VPN with Static Labels

This section describes the procedures required to configure the system as an MPLS-CE to interact with a PE with static MPLS label support.

The base configuration, as described in the *Routing* chapter in this guide, must be completed prior to attempt the configuration procedure described below.



Important The feature described in this chapter is a licensed Cisco feature. A separate feature license may be required. Contact your Cisco account representative for detailed information on specific licensing requirements.



Important Commands used in the configuration samples in this section provide base functionality to the extent that the most common or likely commands and/or keyword options are presented. In many cases, other optional commands and/or keyword options are available. Refer to the *Command Line Interface Reference* for complete information regarding all commands.

To configure the system for BGP/MPLS VPN:

-
- Step 1** Create a VRF on the router and assign a VRF name by applying the example configuration in [Create VRF with Route-distinguisher and Route-target, on page 775](#).
- Step 2** Set the neighbors and address family to exchange routing information and establish BGP peering with a peer router by applying the example configuration in [Set Neighbors and Enable VPNv4 Route Exchange, on page 775](#).
- Step 3** Configure the address family and redistribute the connected routes domains into BGP by applying the example configuration in [Configure Address Family and Redistributed Connected Routes, on page 776](#). This takes any routes from another protocol and redistributes them to BGP neighbors using the BGP protocol.
- Step 4** Configure IP Pools with MPLS labels for input and output by applying the example configuration in [Configure IP Pools with MPLS Labels, on page 776](#).
- Step 5** *Optional.* Bind DHCP service to work with MPLS labels for input and output in corporate networks by applying the example configuration in [Bind DHCP Service for Corporate Servers, on page 776](#).
- Step 6** *Optional.* Bind AAA/RADIUS server group in corporate network to work with MPLS labels for input and output by applying the example configuration in [Bind AAA Group for Corporate Servers, on page 777](#).
- Step 7** Save your configuration as described in the *System Administration Guide*.
-

Create VRF with Route-distinguisher and Route-target

Use this example to first create a VRF on the router and assign a VRF name. The second `ip vrf` command creates the route-distinguisher and route-target.

```
configure
context <context_name> -noconfirm
  ip vrf <vrf_name>
    router bgp <as_number>
      ip vrf <vrf_name>
        route-distinguisher {<as_value> | <ip_address>} <rt_value>
        route-target export {<as_value> | <ip_address>} <rt_value>
      end
    end
```

Set Neighbors and Enable VPNv4 Route Exchange

Use this example to set the neighbors and address family to exchange VPNv4 routing information with a peer router.

```
configure
context <context_name>
  router bgp <as_number>
    neighbor <ip_address> remote-as <AS_num>
    address-family vpnv4
      neighbor <ip_address> activate
      neighbor <ip_address> send-community both
    exit
  interface <bind_intf_name>
    ip address <ip_addr_mask_combo>
  end
```

Configure Address Family and Redistributed Connected Routes

Use this example to configure the **address-family** and to **redistribute** the connected routes or IP pools into BGP. This takes any routes from another protocol and redistributes them using the BGP protocol.

```
configure
context <context_name>
router bgp <as_number>
address-family ipv4 <type> vrf <vrf_name>
redistribute connected
end
```



Note StarOS considers the below address range as Martian and hence rejects any BGP updates falling under this range.

Also, StarOS does not allow BGP network command to configure from the below ranges.

- 127.x.x.x
- 128.0.x.x
- 191.255.x.x
- 192.0.0.x
- 223.255.255.x

Configure IP Pools with MPLS Labels

Use this example to configure IP Pools with MPLS labels for input and output.

```
configure
context <context_name> -noconfirm
ip pool <name> <ip_addr_mask_combo> private vrf <vrf_name> mpls-label input
<in_label_value> output <out_label_value1> nexthop-forwarding-address
<ip_addr_bgp_neighbor>
end
```

Bind DHCP Service for Corporate Servers

Use this example to bind DHCP service with MPLS labels for input and output in Corporate network.

```
configure
context <dest_ctxt_name>
interface <intfc_name> loopback
ip vrf forwarding <vrf_name>
ip address <bind_ip_address subnet_mask>
exit
dhcp-service <dhcp_svc_name>
dhcp ip vrf <vrf_name>
bind address <bind_ip_address> [ nexthop-forwarding-address
```



```
<nexthop_ip_address> [ mpls-label input <in_mpls_label_value> output
<out_mpls_label_value1> [ <out_mpls_label_value2> ]]]
    dhcp server <ip_address>
end
```

Notes:

- To ensure proper operation, DHCP functionality should be configured within a destination context.
- Optional keyword **nexthop-forwarding-address** <ip_address> **mpls-label input** <in_mpls_label_value> **output** <out_mpls_label_value1> applies DHCP over MPLS traffic.

Bind AAA Group for Corporate Servers

Use this example to bind AAA server groups with MPLS labels for input and output in Corporate network.

```
configure
context <dest_ctxt_name>
  aaa group <aaa_grp_name>
    radius ip vrf <vrf_name>
    radius attribute nas-ip-address address <nas_address>
  nexthop-forwarding-address <ip_address> mpls-label input <in_mpls_label_value>
  output <out_mpls_label_value1>
    radius server <ip_address> encrypted key <encrypt_string> port <iport_num>

end
```

Notes:

- *aaa_grp_name* is a pre-configured AAA server group configured in Context Configuration mode. Refer *AAA Interface Administration Reference* for more information on AAA group configuration.
- Optional keyword **nexthop-forwarding-address** <ip_address> **mpls-label input** <in_mpls_label_value> **output** <out_mpls_label_value1> associates AAA group for MPLS traffic.

Configuring BGP/MPLS VPN with Dynamic Labels

This section describes the procedures required to configure the system as an MPLS-CE to interact with a PE with dynamic MPLS label support.

The base configuration, as described in the *Routing* chapter in this guide, must be completed prior to attempt the configuration procedure described below.



Important

The features described in this chapter is an enhanced feature and need enhanced feature license. This support is only available if you have purchased and installed particular feature support license on your chassis.



Important Commands used in the configuration samples in this section provide base functionality to the extent that the most common or likely commands and/or keyword options are presented. In many cases, other optional commands and/or keyword options are available. Refer to the *Command Line Interface Reference* for complete information regarding all commands.

To configure the system for BGP/MPLS VPN:

-
- Step 1** Create a VRF on the router and assign a VRF name by applying the example configuration in [Create VRF with Route-distinguisher and Route-target, on page 778](#).
 - Step 2** Set the neighbors and address family to exchange routing information and establish BGP peering with a peer router by applying the example configuration in [Set Neighbors and Enable VPNv4 Route Exchange, on page 779](#).
 - Step 3** Configure the address family and redistribute the connected routes domains into BGP by applying the example configuration in [Configure Address Family and Redistributed Connected Routes, on page 779](#). This takes any routes from another protocol and redistributes them to BGP neighbors using the BGP protocol.
 - Step 4** Configure IP Pools with dynamic MPLS labels by applying the example configuration in [Configure IP Pools with MPLS Labels, on page 779](#).
 - Step 5** *Optional.* Bind DHCP service to work with dynamic MPLS labels in corporate networks by applying the example configuration in [Bind DHCP Service for Corporate Servers, on page 779](#).
 - Step 6** *Optional.* Bind AAA/RADIUS server group in corporate network to work with dynamic MPLS labels by applying the example configuration in [Bind AAA Group for Corporate Servers, on page 780](#).
 - Step 7** *Optional.* Modify the configured IP VRF, which is configured to support basic MPLS functionality, for mapping between DSCP bit value and experimental (EXP) bit value in MPLS header for ingress and egress traffic by applying the example configuration in [DSCP and EXP Bit Mapping, on page 780](#).
 - Step 8** Save your configuration as described in the *System Administration Guide*.
-

Create VRF with Route-distinguisher and Route-target

Use this example to first create a VRF on the router and assign a VRF name. The second **ip vrf** command creates the route-distinguisher and route-target.

```
configure
context <context_name> -noconfirm
  ip vrf <vrf_name>
  router bgp <as_number>
    ip vrf <vrf_name>
      route-distinguisher {<as_value> | <ip_address>} <rt_value>
      route-target export {<as_value> | <ip_address>} <rt_value>
      route-target import {<as_value> | <ip_address>} <rt_value>
    end
```

Notes:

- If export and import route targets are the same, alternate command **route-target both** {<as_value> | <ip_address>} <rt_value> can be used in place of **route-target import** and **route-target export** commands.

Set Neighbors and Enable VPNv4 Route Exchange

Use this example to set the neighbors and address family to exchange VPNv4 routing information with a peer router.

```
configure
context <context_name>
  mpls bgp forwarding
  router bgp <as_number>
    neighbor <ip_address> remote-as <AS_num>
    address-family vpnv4
    neighbor <ip_address> activate
    neighbor <ip_address> send-community both
  exit
interface <bind_intf_name>
  ip address <ip_addr_mask_combo>
end
```

Configure Address Family and Redistributed Connected Routes

Use this example to configure the **address-family** and to **redistribute** the connected routes or IP pools into BGP. This takes any routes from another protocol and redistributes them using the BGP protocol.

```
configure
context <context_name>
  router bgp <as_number>
    address-family ipv4 <type> vrf <vrf_name>
    redistribute connected
  end
```

Configure IP Pools with MPLS Labels

Use this example to configure IP Pools with dynamic MPLS labels.

```
configure
context <context_name> -noconfirm
  ip pool <name> <ip_addr_mask_combo> private vrf <vrf_name>
end
```

Bind DHCP Service for Corporate Servers

Use this example to bind DHCP service with dynamic MPLS labels in Corporate network.

```
configure
context <dest_ctxt_name>
  interface <intfc_name> loopback
    ip vrf forwarding <vrf_name>
    ip address <bind_ip_address subnet_mask>
  exit
  dhcp-service <dhcp_svc_name>
    dhcp ip vrf <vrf_name>
```

```

bind address <bind_ip_address>
dhcp server <ip_address>
end

```

Notes:

- To ensure proper operation, DHCP functionality should be configured within a destination context.

Bind AAA Group for Corporate Servers

Use this example to bind AAA server groups with dynamic MPLS labels in Corporate network.

```

configure
context <dest_ctxt_name>
  aaa group <aaa_grp_name>
    radius ip vrf <vrf_name>
    radius attribute nas-ip-address address <nas_address>
    radius server <ip_address> encrypted key <encrypt_string> port <iport_num>

  end

```

Notes:

- *aaa_grp_name* is a pre-configured AAA server group configured in Context Configuration mode. Refer *AAA Interface Administration Reference* for more information on AAA group configuration.

DSCP and EXP Bit Mapping

Use this example to modify the configured IP VRF to support QoS mapping.

```

configure
context <context_name>
  ip vrf <vrf_name>
    mpls map-dscp-to-exp dscp <dscp_bit_value> exp <exp_bit_value>
    mpls map-exp-to-dscp exp <exp_bit_value> dscp <dscp_bit_value>
  end

```



CHAPTER 37

Multiple IP Versions Support

This chapter describes the following topics:

- [Feature Summary and Revision History, on page 781](#)
- [Feature Description, on page 782](#)
- [How it Works, on page 782](#)
- [Configuring Multiple IP Version Support, on page 784](#)
- [Monitoring and Troubleshooting, on page 785](#)

Feature Summary and Revision History

Summary Data

Applicable Product(s) or Functional Area	<ul style="list-style-type: none">• P-GW• S-GW• SAEGW
Applicable Platform(s)	<ul style="list-style-type: none">• ASR 5500• VPC - DI• VPC - SI
Feature Default	Disabled - Configuration Required
Related Changes in This Release	Not applicable
Related Documentation	<ul style="list-style-type: none">• <i>Command Line Interface Reference</i>• <i>P-GW Administration Guide</i>• <i>S-GW Administration Guide</i>• <i>SAEGW Administration Guide</i>

Revision History



Important Revision history details are not provided for features introduced before release 21.2 and N5.1.

Revision Details	Release
This feature enables P-GW, S-GW, and SAEGW nodes to support the control messages received on all the transport addresses exchanged during the session setup.	21.8
First introduced.	Pre 21.2

Feature Description

This feature enables P-GW, S-GW, and SAEGW nodes to support the control messages received on all the transport addresses exchanged during the session setup.

A new CLI command has been introduced at the egtp-service level to control the behavior of the BRCmd, MBCmd, and DBCmd messages.

How it Works

This section describes the working of this feature. Following is the sample call flow for MBCmd.

The following figure illustrates call flow when the feature is disabled:

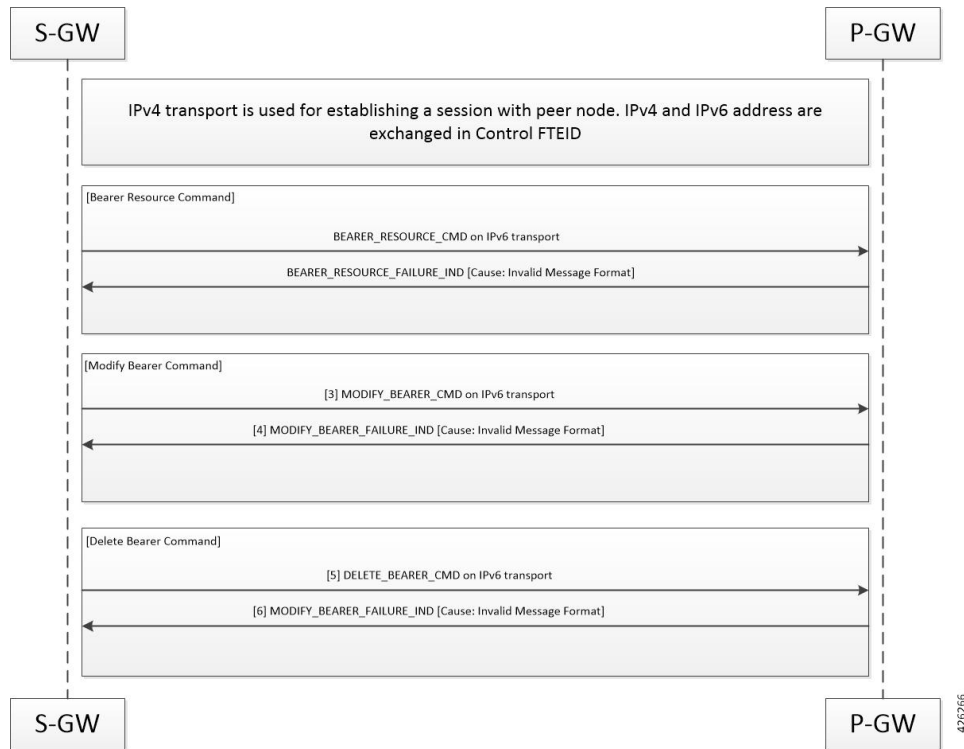

The following figure illustrates the call flow when feature is enabled:

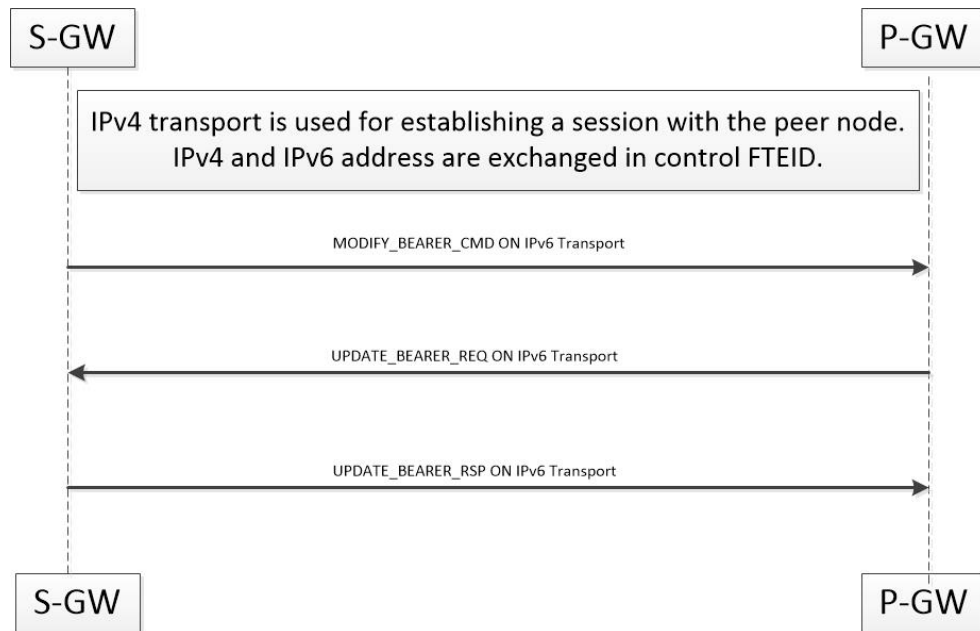

When a session is being established, P-GW, S-GW, and SAEGW node uses the IPv6 address as transport. This transport is used for establishing tunnel with peer node. If IPv4 and IPv6 addresses are exchanged in control FTEID then the node should handle MBCmd, BRCmd, and DBCmd messages on IPv4 transport by the nodes.

When a session is being established, if IPv4 address is used as a transport and is being used for establishing tunnel with peer node, and if IPv4 and IPv6 addresses are exchanged in control FTEID, then the MBCmd, BRCmd, and DBCmd messages are also handled on the IPv6 transport by the nodes.

When a session is being established, if IPv4 and IPv6 addresses are exchanged in data F-TEID by both peers, then the GTP-U data packets get handled on both IPv6 and IPv4 transport.

When a session is being established, if IPv4 address is used as a transport, however, C-TEID does not contain IPv4 address, then that message is rejected by the node. The nodes exhibit similar behavior for IPv6 addresses.

When a session is being established, if IPv4 and IPv6 addresses are exchanged in data F-TEID by both peers, then GTP-U data packets get handled on IPv6 and IPV4 transport both.

The following table displays the message handling behavior in different session establishment scenarios:

Table 69: Message Handling Behavior in Different Session Establishment Scenarios

Messages	Transport Used for Session Establishment	C-FTEID Sent During Session Establishment	Message Sent on Transport
MBR/DSR	IPv6	IPv4/IPv6	IPv4
MBC/DBC/BRC	IPv6	IPv4/IPv6	IPv4
Change Notification	IPv6	IPv4/IPv6	IPv4
Suspend/Resume	IPv6	IPv4/IPv6	IPv4
MBR/DSR	IPv4	IPv4/IPv6	IPv6
MBC/DBC/BRC	IPv4	IPv4/IPv6	IPv6
Change Notification	IPv4	IPv4/IPv6	IPv6
Suspend/Resume	IPv4	IPv4/IPv6	IPv6
MBR/DSR	IPv6	IPv6	IPv4
MBC/DBC/BRC	IPv6	IPv6	IPv4
Change Notification	IPv6	IPv6	IPv4
Suspend/Resume	IPv6	IPv6	IPv4
MBR/DSR	IPv4	IPv4	IPv6
MBC/DBC/BRC	IPv4	IPv4	IPv6
Change Notification	IPv4	IPv4	IPv6
Suspend/Resume	IPv4	IPv4	IPv6

Configuring Multiple IP Version Support

This section provides information on CLI commands available in support of this feature.

By default, this feature is enabled.

configure

```
context context_name
  egtp-service service_name
    [no] gtpc command-messages dual-ip-stack-support
  end
```

NOTES:

- **no**: Disables the feature.
- **command-messages**: Configures MBC or DBC or BRC messages on S-GW and P-GW.
- **dual-ip-stack-support**: Enables P-GW, S-GW, SAEGW nodes to handle command messages on both IPv4/IPv6 transport, if supported.

Monitoring and Troubleshooting

This section provides information on how to monitor and troubleshoot the Override Control Enhancement feature.

Show Commands and Outputs

This section provides information on show commands and their corresponding outputs for the Override Control Enhancement feature.

show configuration

The following new fields are added to the output of this command:

- **gtpc command-messages dual-ip-stack-support** - Specifies the command messages on both IPv4/IPv6 transport if supported.

show egtp-service all

The following new fields are added to the output of this command:

- **GTPC Command Messages Dual IP Support** - Specifies the command messages on both IPv4/IPv6 transport if supported.

show egtp-service all



CHAPTER 38

NetLoc for WiFi EPC

This chapter describes StarOS support for the NetLoc for WiFi EPC feature on the P-GW and SAE-GW.

- [Feature Description, on page 787](#)
- [How It Works, on page 787](#)
- [Configuring the NetLoc for WiFi EPC Feature, on page 789](#)
- [Monitoring and Troubleshooting the NetLoc for WiFi EPC Feature, on page 791](#)

Feature Description

With this feature, the IMS network can retrieve location information of the UE from WLAN access network. This improves location related feature and functionality for the operator. This feature also helps in charging subscribers based on location information.

Please note that the support for LTE NetLoc already exists from prior releases. With this release, NetLoc support is extended for WLAN access. Basic implementation is already supported for passing necessary parameter to different internal modules like SM, IMSA and ECS.

How It Works

When the Application Function (AF) requests the PCRF to report the access network information, the PCRF provides the requested access network information indication (for example, user location and/or user timezone information) to the PCEF within the Required-Access-Info AVP which is included in the Charging-Rule-Definition AVP of an appropriate PCC rule.

The PCRF also provides the ACCESS_NETWORK_INFO_REPORT event trigger within the Event-Trigger AVP. If the ACCESS_NETWORK_INFO_REPORT event trigger is set, upon installation, modification and removal of any PCC rule(s) containing the Required-Access-Info AVP, the P-GW determines if it can obtain the required location information for the used IP CAN type.

During bearer deactivation or UE detach procedure, the P-GW provides the access network information to the PCRF within the TWAN-Identifier AVP. The P-GW also provides information on when the UE was last known to be in that location within the User-Location-Info-Time AVP, and/or UE-Local-IP-Address AVP as applicable for S2a/S2b interface:

- For Trusted WLAN, the User Location Information (ULI) is provided in the TWAN Identifier AVP.

- For Untrusted WLAN, the ULI contains the TWAN Identifier, the UE's Local IP address and optionally, UDP source port number (if NAT is detected).

When the ULI is requested by the PCRF and it's not provided to the PCEF, the PCEF provides the serving PLMN identifier within the 3GPP-SGSN-MCC-MNC AVP. And when the time zone is requested by the PCRF, the PCEF provides it within the 3GPP-MS-TimeZone AVP. Please note that the timezone is applicable only for Trusted WLAN interface. For WLAN access, the PCEF also includes the AN-Trusted AVP while reporting access network information.

During the IP-CAN session termination procedure, the PCEF will, if ACCESS_NETWORK_INFO_REPORT event trigger is set, provide the access network information to the PCRF by including the ULI (if it was provided to the PCEF), the information on when the UE was last known to be in that location within User-Location-Info-Time AVP (if it was provided to the PCEF), the PLMN identifier within the 3GPP-SGSN-MCC-MNC AVP (if the user location information was not provided to the PCEF) and the timezone information within the 3GPP-MS-TimeZone AVP.

The WLAN location information received from S2a/S2b interface is reported on all the P-GW supported interfaces (Gx, Gy, and Gz).

Accounting Requirements

As part of accounting requirements, the following Dictionaries are used:

- Gx: r8-gx-standard
- Gy:
 - S2a: custom-8 with Rel-11
 - S2b: custom-8 with Rel-13
- Gz:
 - S2a: custom-48 and custom-52
 - S2b: custom-52

The following fields in PGW-CDRs are introduced as part of Gz requirement:

- custom-52 dictionary (as part of uWANUserLocationInfo):
 - uELocalIPAddress
 - uDPSourcePort
 - sSID
 - bSSID

The custom-52 is a new standard dictionary introduced in compliance with 3GPP Release 13.

Limitations

This section identifies the known limitations/restrictions of this feature.

- The User Location Information (ULI) on S2b includes UE local IP address and optionally, UDP source port number (if NAT is detected). It also includes WLAN Location Information (and its age). Location change is considered if any of the following information changes: UE local IP address, UDP port, or WLAN Location.
- On Gz, for WLAN location change, the ULI change trigger is used.
- On Gy, for WLAN location change, the location_any trigger is used.
- The Rf and S2a RADIUS, and LI interfaces are not considered as part of this feature.
- There are no changes done over S6b interface.
- Only SSID and BSSID of TWAN/UWAN Identifier are considered as part of this feature.
- UE local IP address field is mandatory on Gz and Gy as part of UWANUserLocationInfo.
- For S2b, when the received UWANUserLocationInfo is different than the previous UWANUserLocationInfo, then below are few error case handling:
 - For Gy, if the received parameters doesn't contain IP Address, the P-GW doesn't generate a ULI-Change report.
 - For Gz, the container with 'ULI change' is closed only when the UWANUserLocationInfo value corresponding to the container contains the IP-Address.
- This feature is controlled by NetLoc and Wifi Integration License.
- In case of S2b interface, UE Local IP Address and Port, WLAN ID and WLAN Timestamp are reset to 0 if they are not received in CSReq/CBRsp/UBRsp/DBRsp.
- As per 3GPP TS 32.298, TWAN Identifier is present at Record level in Gz.
- The WLAN-timestamp is not sent over Gy and Gz interface.
- The UE-location-IP-Address change event trigger is not part of this feature.
- The EPC_Routed Feature (Reference 3GPP TS 29.212) is not supported.

Configuring the NetLoc for WiFi EPC Feature

The following sections provide the configuration commands to enable the feature.

Configuring the NetLoc TWAN for Gx

The commands illustrated below configures the NetLoc trusted WLAN feature over Gx interface.

```

configure
  context context_name
    ims-auth-service service_name
      policy-control
        diameter encode-supported-features netloc-trusted-wlan
      end
    end
  end

```

Notes:

- **no diameter encode-supported-features**: Disables the feature.
- This command takes effect when Gx is enabled on S2b call.
- By default, the feature is disabled and TWAN information will not be sent over Gx.

Configuring the NetLoc UWAN for Gx

The commands illustrated below configures the NetLoc untrusted WLAN feature over Gx interface.

```
configure
  context context_name
    ims-auth-service service_name
      policy-control
        diameter encode-supported-features netloc-untrusted-wlan
      end
    end
```

Notes:

- **no diameter encode-supported-features**: Disables the feature.
- This command takes effect when Gx is enabled on S2b call.
- By default, the feature is disabled and UWAN information will not be sent over Gx.

Configuring the NetLoc UWAN for Gy

The commands illustrated below configures dictionary control of the AVPs that need to be added based on 3GPP Rel.13.

```
active-charging service service_name
  credit-control
    diameter update-dictionary-avps 3gpp-rel13
  end
```

Notes:

- **no diameter update-dictionary-avps**: Disables the feature.
- This command takes effect when Gy is enabled on S2b call.
- By default, the feature is disabled and UWAN information will not be sent over Gy.

Configuring the NetLoc UWAN for Gz

The commands illustrated below configures the NetLoc untrusted WLAN feature over Gz interface.

```
configure
  context context_name
    gtp group group_name
      gtp attribute uwanuli
    end
  end
```

Notes:

- **no gtp attribute uwanuli**: Disables the feature.
- This command takes effect when Gz is enabled on S2b call.
- By default, the feature is disabled and UWAN information will not be sent over Gz.

Monitoring and Troubleshooting the NetLoc for WiFi EPC Feature

This section provides information regarding show commands and/or their outputs in support of this feature.

Show Commands and/or Outputs

The following table lists the CLI commands that will help to monitor and/or troubleshoot this feature.

CLI Commands	Description
show subscribers pgw-only full all show subscriber saegw-only full all	Displays the following newly introduced fields for which the values will be populated on S2a/S2b calls: TWAN User Location Information: SSID: BSSID: UWAN User Location Information: UE Local IP Address: UDP Port: SSID: BSSID:
show ims-authorization service all verbose	Displays the following newly introduced fields for which the values will be populated when they are configured as Supported Features AVP in IMS Authorization Service Configuration mode: <ul style="list-style-type: none"> • netloc-trusted-wlan • netloc-untrusted-wlan
show gtp group all	Displays the following newly introduced field for which the value will be populated when the gtp attribute uwanuli CLI command is configured in the GTPP Server Group configuration mode: <ul style="list-style-type: none"> • UWAN User Location Information present:



CHAPTER 39

Network Mobility (NEMO)

This chapter describes the system's support for NEMO and explains how it is configured. The product administration guides provide examples and procedures for configuration of basic services on the system. It is recommended that you select the configuration example that best meets your service model and configure the required elements for that model, as described in the *Cisco ASR 5500 Packet Data Network Gateway Administration Guide*, before using the procedures in this chapter.

- [NEMO Overview, on page 793](#)
- [NEMO Configuration, on page 800](#)

NEMO Overview

When enabled through a feature license key, the system includes NEMO support for a Mobile IPv4 Network Mobility (NEMO-HA) on the P-GW platform to terminate Mobile IPv4 based NEMO connections from Mobile Routers (MRs) that attach to an Enterprise PDN. The NEMO functionality allows bi-directional communication that is application-agnostic between users behind the MR and users or resources on Fixed Network sites.

The same NEMO4G-HA service and its bound Loopback IP address supports NEMO connections whose underlying PDN connection comes through GTP S5 (4G access) or PMIPv6 S2a (eHRPD access).

Multiple HA service configuration is required when a mobile network is multihomed, that is when there is more than one point of attachment between the mobile network and internet.

The following figure shows a high-level view of LTE NEMOv4 Architecture.

Figure 123: NEMO Overview

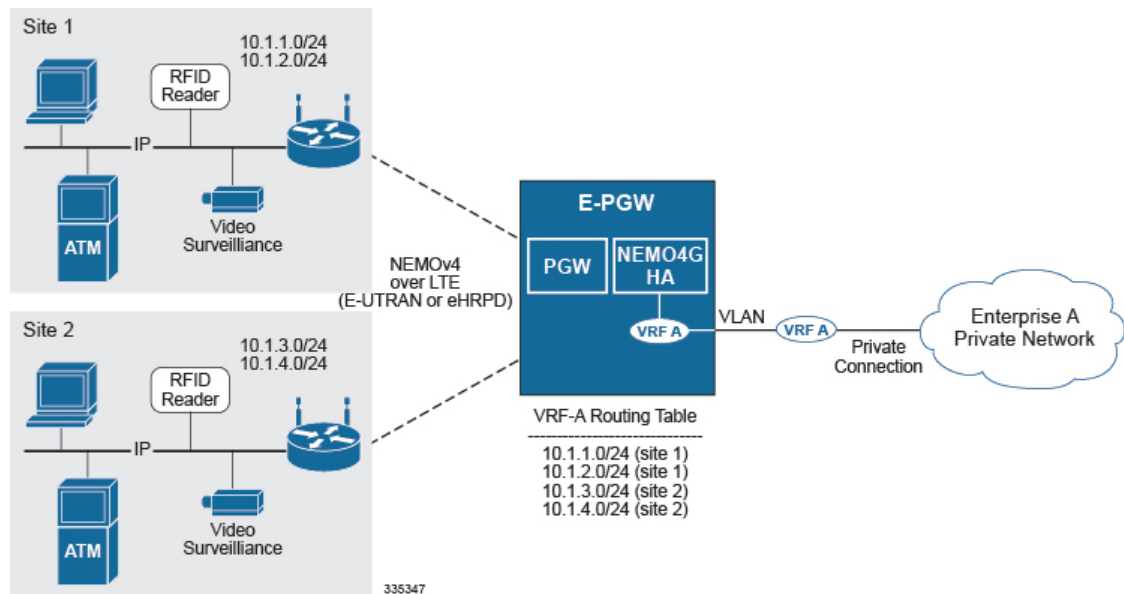

Use Cases

The following use cases are supported by NEMO in LTE:

1. **Stationary** - Applications, like branch offices, with a mobile router that does not require mobility.
2. **Nomadic** - Applications that use a mobile router that does not move while in service, but that may be moved to a different location and brought back on service (e.g. a kiosk showing up in a mall one day and in a different location the next day or month).
3. **Moveable** - Applications that need to maintain Dynamic Mobile Network Routing (DMNR) service operational while moving and crossing PDSN boundaries, such as public safety vehicles. Service continuity is handled by the mobility protocols (Mobile IP in 3G and GTP in LTE).

Features and Benefits

The system supports the usage of dynamically learned, overlapping customer prefixes. These prefixes are advertised via BGP.

MIPv4-based NEMO Control Plane

The following figure shows a high-level view of the NEMO control plane.

Figure 124: NEMO Control Plane

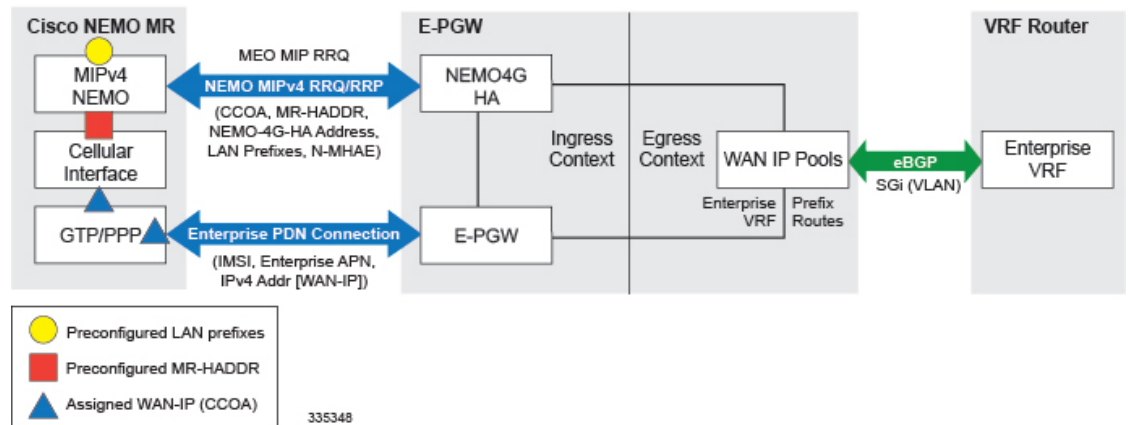

NEMO includes the following features:

- Collocated-Care-of-Address mode

The Cisco NEMO MR is expected to use the Collocated-Care-of-Address mode to establish a NEMO MIPv4 session with NEMO4G-HA and as one of the IP endpoints of the NEMO GRE Tunnel for the transport of user traffic.

- MR-HADDR

NEMO4G-HA supports a potential "dummy" MR-HADDR address that would be configured in every MR within the same Enterprise or across all served Enterprises (same IP address).

- Dynamic advertisement of WAN-IP Pools and learned LAN prefixes

eBGP is used to advertise the Enterprise WAN-IP Pools and the LAN prefixes learned via NEMO for the associated Enterprise.

- N-MHAE credentials

NEMO4G-HA supports local authentication for the NEMO MIPv4 RRQ based on preconfigured N-MHAE-SPI/KEY values on a per Enterprise basis (one unique set for all MRs belonging to the same Enterprise) or on a global basis (one unique set for all Enterprises).

- LAN prefixes

- NEMO4G-HA accepts a minimum of zero LAN prefixes and a maximum of eight prefixes per mobile router. Anything beyond eight prefixes shall be silently discarded.
- NEMO4G-HA supports any prefix length (including /32).
- NEMO4G-HA supports dynamic prefix updates.
 - NEMO4G-HA removes from the associated Enterprise VRF routing table any prefixes that are not included in a scheduled or ad-hoc NEMO MIPv4 re-registration request from a given MR (assuming these were present in a previous NEMO MIPv4 RRQ). E-PGW shall update the external VRF router of the removal of such prefixes on the next eBGP update.
 - NEMO4G-HA accepts and installs any new prefixes that are included in a scheduled or ad-hoc NEMO MIPv4 re-registration request to the associated Enterprise VRF routing table, as long as it doesn't exceed the maximum number of supported prefixes per MR (up to eight). E-PGW shall update the external VRF router of the newly installed prefixes on the next eBGP update.

NEMO4G-HA shall accept NEMO MIPv4 RRQs that do not include any prefixes in the first initial RRQ and it shall accept prefixes advertised in subsequent RRQs.

- In case of a prefix whose IP address or mask is changed on the MR, the MR will remove the old IP address/mask and add the new IP address/mask prefix in a scheduled or ad-hoc NEMO MIPv4 re-registration request and NEMO4G-HA shall remove the old route and add the new route corresponding to the new prefix to the Enterprise VRF routing table

- Overlapping IP addressing

NEMO4G-HA supports private and overlapping IP addressing across multiple Enterprises for the WAN IP pools, MR-HADDR, and LAN prefixes.

NEMO MR Authorization

NEMO4G-HA authorizes a NEMO MIPv4 session only if a NEMO permission has been assigned to the underlying PDN connection. NEMO permission should be assigned to the underlying PDN connection via either local configuration (APN parameter) or based on a NEMO permission AVP assigned by the 3GPP AAA during the PDN authorization. For local configuration, a new APN parameter is supported to enable NEMO permission at the APN/PDN level within the P-GW service.

MIPv4 NEMO Protocol

NEMO4G-HA processes a Mobile IPv4 NEMO Registration Request (RRQ) received from the MR NEMO client.

NEMO4G-HA processes the first of three Cisco-specific MIPv4 Extensions of type Normal Vendor/Org Specific Extension (NVSE) that are included in the MIPv4 NEMO RRQ. The three Cisco-specific NVSEs are placed after the MIPv4 "Identification" field and before the mandatory MIPv4 "Mobile-Home-Authentication-Extension." NEMO4G-HA accepts the LAN prefixes (up to eight) encoded in the first Cisco-specific NVSE (vendor-type = 9). NEMO4G-HA is not expected to process the other two Cisco-specific NVSEs with vendor-type = 49, which carry the Internal Interface ID of the MR's Roaming Interface and the MR's Roaming Interface Bandwidth in Kbps, respectively.

Cisco-specific NVSEs follow RFC 3025 "Mobile IP Vendor/Organization Specific Extensions."

GRE Encapsulation

User traffic shall be encapsulated over a GRE tunnel between the MR NEMO client and NEMO4G-HA. The IP endpoints of the GRE tunnel shall be the IPv4 assigned to the MR modem during the Enterprise PDN connection setup and the IPv4 address of the NEMO4G-HA service on the E-PGW.

NEMO4G-HA shall remove the GRE encapsulation before it forwards the outbound traffic towards the Enterprise VPN via the associated SGi VLAN interface. Inbound traffic received through the same SGi VLAN interface shall be encapsulated into a GRE tunnel before it's passed to the E-PGW service for forwarding to the MR through the proper GTP/PMIP tunnel.

Session Interactions

The following session interaction scenarios are supported between NEMO and the underlying PDN connection made over eHRPD or LTE access.

In the following circumstances, NEMO4G-HA shall withdraw the associated prefix routes from the Enterprise VRF routing table, update the eBGP neighbors and free up all internal resources allocated for the underlying PDN connection and NEMO session:

- When the eHRPD terminates the underlying PDN connection (PPP-VSNCP-Term-Req sent to MR and PMIP-BU with lifetime = 0 sent to E-PGW).
- When the MR terminates the PPP/PDN connection when accessing the network via eHRPD.
- After an eUTRAN (LTE) detach procedure initiated by the MR or MME.

NEMO4G-HA shall not be able to process any NEMO MIPv4 RRQs if there's no underlying PDN connection associated to those RRQs (PMIPv6 or GTP). In other words, NEMO MIPv4 RRQs can be accepted and processed only if an Enterprise PDN connection has been established with E-PGW by the mobile router.

NEMO4G-HA shall silently ignore NEMO MIPv4 RRQs if the underlying PDN connection associated to each of those RRQs does not have the NEMO permission indication. This applies to both eHRPD and LTE access.

NEMO4G-HA shall forward (not drop) user data using MIP or GRE tunneling (UDP/434 or IP Protocol/47, respectively) to the external enterprise VRF if such data is not destined to the NEMO4G-HA IP address. This applies to PDN connections that have or do not have the NEMO Permission indication. This shall also apply to both eHRPD and LTE access.

Any failure on either the authentication or authorize of a NEMO MIPv4 session shall not affect the underlying PDN connection established between the mobile router and the E-PGW via eHRPD or LTE. For example, if the security credentials do not match between the MR NEMO client and NEMO4G-HA, NEMO4G-HA can reject the NEMO MIPv4 RRQ, but the associated PDN connection shall not be terminated.

NEMO Session Timers

NEMO4G-HA uses the registration lifetime value locally configured, even though MR's may use the maximum possible value (65534).

NEMO4G-HA can process ad-hoc NEMO RRQ messages.

Enterprise-wide Route Limit Control

NEMO4G-HA supports a control mechanism to limit the maximum number of prefixes/routes that a given enterprise can register, including the pools for WAN IP assignments.

When the maximum number of routes is reached, a syslog message is generated. Once the number of routes goes under the limit, a syslog message is generated for notification.

Forced Fragmentation

E-PGW forces IP packet fragmentation even for IP packets with the DF-bit set.

Redundancy/Reliability

The LTE NEMO solution supports intra-chassis Session Redundancy (SR) and Inter-Chassis Session Redundancy (ICSR) functionalities.

LTE NEMO Call Flow

The following figure describes the call flow of the NEMOv4 solution.

Figure 125: NEMOv4 Call Flow

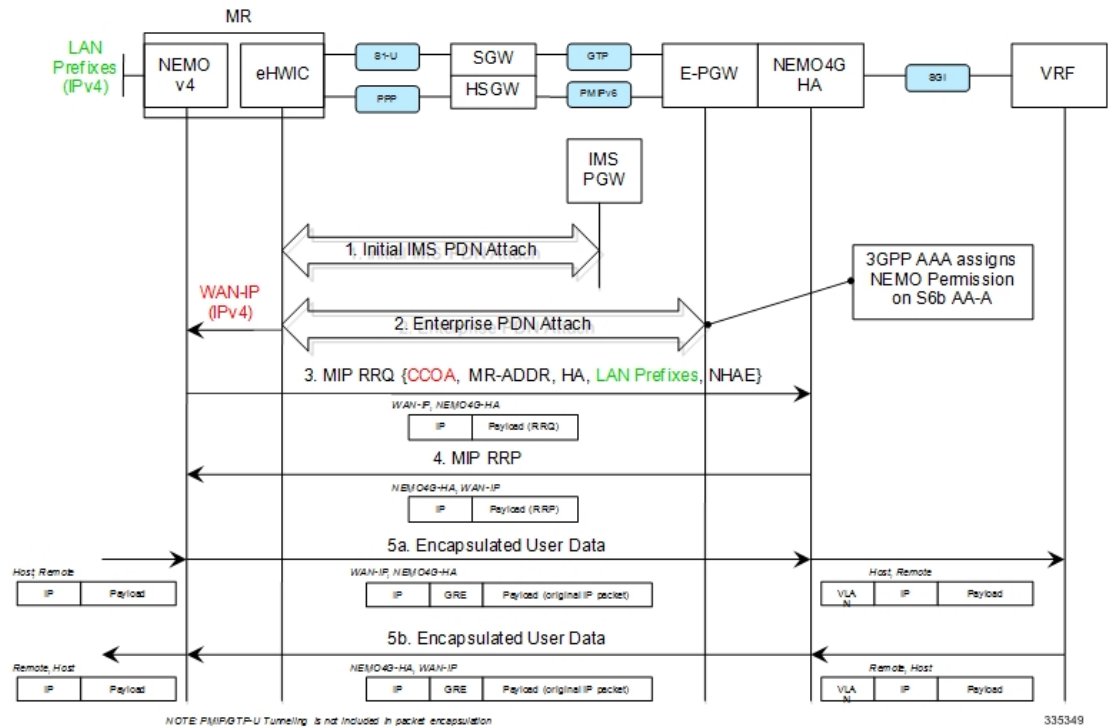

- The Cisco MR eHWIC establishes first a connection to the IMS PDN to register to the LTE Network. The eHWIC's User Id must be properly provisioned on the HSS/SPR to be successfully authenticated.
- After the Cisco MR eHWIC registers with the LTE network and establishes a connection to the IMS PDN, then it connects to the appropriate Enterprise PDN based on the locally configured Enterprise APN.
 - During the PDN authorization procedure using S6b, the 3GPP AAA assigns a NEMO permission via AVP. The AVP is also be available as an APN parameter on the E-PGW to allow NEMO service at the PDN/Enterprise level.
 - E-PGW assigns the MR eHWIC an IPv4 address from the Enterprise IPv4 pool assigned during PDN authentication.
 - E-PGW creates the proper flows internally to forward packets to the corresponding VRF external to the E-PGW platform using the IPv4 pool configuration on the egress context.
 - The MR eHWIC passed on the assigned IPv4 address to the NEMO application (also called WAN-IPv4 address).
- The MR NEMO application initiates a Mobile IPv4 registration request (RRQ) using the following local configuration and the IPv4 address assigned to the eHWIC during the Enterprise PDN attach procedure (referred to as WAN-IP). The NEMO MIPv4 RRQ will be carried as a regular user packet over the mobility connection, either GTP in LTE and PPP/PMIPv6 in eHRPD. The NEMO MIPv4 RRQ includes the following key parameters:

- CCOA - IPv4 address assigned to the eHwIC modem during the Enterprise PDN connection setup (WAN-IP). The MR NEMO application will use the CCOA/WAN-IP address as the source of all NEMO packets sent to NEMO4G-HA (control and tunneled user traffic).
 - MR-HADDR - Mandatory IPv4 address preconfigured in the MR NEMO application. MR-HADDR is normally used as the source of all NEMO control packets sent to the NEMO4G-HA. However, the MR NEMO application will use the CCOA as the source for all NEMO packets (control and tunneled user traffic). Therefore, NEMO4G-HA will ignore the preconfigured MR-HADDR included in the RRQ, but it will still include it in the NEMO MIPv4 RRP.
 - Home Agent Address - Preconfigured IPv4 address that the MR NEMO application uses as the destination for all NEMO control and GRE tunneled user data (NEMO4G-HA's IPv4 Address).
 - Explicit LAN Prefixes - Locally attached IPv4 networks preconfigured on the MR NEMO application. LAN prefixes will be encoded in the same Cisco NVSE extension currently used in the NEMO solution for 3G. The Cisco NVSE included in the NEMOv4 MIP RRQ is in the form of a TLV.
 - N-MHAE - Mandatory NEMO MN-HA Authentication Extension that includes the SPI and the authenticator computed using a pre-shared Key. Both SPI and Key are preconfigured in the MR NEMO application as well.
 - NEMO-Tunnel flags such as, but not limited to, "Reverse Tunnel," "Direct Termination," "Tunnel Encapsulation" = GRE.
4. NEMO4G-HA sends a MIP registration response (RRP) back to the MR after it performs the following tasks:
- Authenticate the RRQ using the N-MHAE information included in the RRQ.
 - Authorize the NEMO service based on the NEMO permission attribute assigned to the associated Enterprise PDN connection.
 - Accept the prefixes advertised in the Cisco NVSE extension included in the NEMO MIPv4 RRQ.
 - The learned prefixes will have to adhere to the current rules of valid pool routes. The minimum valid mask length is /13 and pool routes can not include 0.0.0.0 or 255.255.255.255.
 - NEMO4G-HA will accept a minimum of 0 prefixes and a maximum of 8 prefixes. Anything beyond 8 prefixes will be silently discarded.
 - NEMO4G-HA will also check that the new resultant enterprise route count (total number of VRF routes) do not exceed the route limit potentially configured for the given enterprise. If the preconfigured route limit is exceeded, then NEMO4G-HA will reject the NEMO MIP RRQ. Otherwise, NEMO4G-HA will install the accepted prefixes in the internal VRF associated with the Enterprise PDN.
 - eBGP would then propagate the new NEMO routes to the external VRF as part of the next BGP update.
5. Upon receiving the NEMO MIP RRP, the MR will install a default route (0.0.0.0/0) in its routing table to route all traffic through the LTE connection.
- Outbound packets are encapsulated over GRE using the CCOA/WAN-IP address as the source and the NEMO4G-HA-Service IPv4 address as the destination of the tunnel.

- Inbound packets are encapsulated over GRE as well from the NEMO4G-HA to the MR NEMO application. The source of the GRE tunnel is the NEMO4G-HA-Service IPv4 address and the destination is the CCOA/WAN-IP address.

Engineering Rules

- Up to 5,000 host routes spread across multiple VRFs per BGP process. Limited to 6,000 pool routes per chassis.
- Up to 2,048 VRFs per chassis.

Supported Standards

- IETF RFC 3025 (February 2001) "Mobile IP Vendor/Organization Specific Extensions"
- IETF RFC 1191 (November 1990) "Path MTU Discovery"

NEMO Configuration



Important Commands used in the configuration samples in this section provide base functionality to the extent that the most common or likely commands and/or keyword options are presented. In many cases, other optional commands and/or keyword options are available. Refer to the *Command Line Interface Reference* for complete information regarding all commands.

To configure the system for NEMO:

1. Create a VRF on the router and assign a VRF-ID by applying the example configuration in [Create a VRF](#).
2. Set the neighbors and address family to exchange routing information with a peer router by applying the example configuration in [Set Neighbors and Address Family, on page 802](#).
3. Redistribute connected routes between routing domains by applying the example configuration in [Redistribute Connected Routes, on page 802](#).
4. Allow the P-GW to use the NEMO service by applying the example in [Configure and Enable NEMO in APN Profile, on page 802](#).
5. Create a NEMO HA by applying the example in [Create a NEMO HA, on page 803](#).
6. Save your configuration to flash memory, an external memory device, and/or a network location using the Exec mode command **save configuration**. For additional information on how to verify and save configuration files, refer to the *System Administration Guide* and the *Command Line Interface Reference*.

Sample Configuration

```

configure
  context <egress_context_name>
  interface <interface_name_outbound>
    ip address <ipv4_address> <ipv4_mask>
    exit
  ip vrf <vrf_name>
  ip vrf-list first-list permit vrf <vrf_name>
  mpls bgp forwarding
  ip pool <pool_name> <pool_address> private vrf <vrf_name>
  nexthop-forwarding-address <ip_address> overlap vlanid <vlan_id>
  router bgp <as_number>
    neighbor <ip_address> remote-as <as_number>
    timers bgp keepalive-interval <seconds> holdtime-interval <seconds>
    address-family <type>
      redistribute connected
    #exit
    address-family <type>
      neighbor <ip_address> activate
      neighbor <ip_address> send-community both
    #exit
    ip vrf <vrf_name>
      route-distinguisher <asn_value> <rd_value>
      route-target both <asn_value> <rt_value>
    #exit
    address-family address-family ipv4 vrf <vrf_name>
      redistribute connected
    #exit
  #exit
  apn <apn_name>
    permission nemo
    ip context-name <egress_context_name>
    ip address pool name <pool_name>
    exit
  exit
  context <inress_context_name>
  interface <interface_name_inbound>
    ip address <ipv4_address> <ipv4_mask>
    exit
  ha-service <ha_service_name>
    mn-ha-spi spi-number <spi_number> encrypted secret <enc_secret>
    authentication mn-aaa noauth
    encapsulation allow keyless-gre
    bind address <ip_address>
    end

```

Refer *Command Line Interface Reference* for detail information about the CLIs and keywords/variables.

Create a VRF

Use this example to first create a VRF on the router and assign a VRF-ID.

```
configure
  context <context_name> -noconfirm
  ip vrf <vrf_name>
  ip pool <pool_name> <pool_address> private vrf <vrf_name>
  nexthop-forwarding-address <ip_address> overlap vlanid <vlan_id>
end
```

Set Neighbors and Address Family

Use this example to set the neighbors and address family to exchange routing information with a peer router.

```
configure
  context <context_name>
  ip vrf <vrf_name>
  router bgp <as_number>
  ip vrf <vrf_name>
  neighbor <ip_address> remote-as <AS_num>
  address-family <type>
  neighbor <ip_address> activate
end
```

Redistribute Connected Routes

Use this example to redistribute connected routes between routing domains.

```
configure
  context <context_name>
  ip vrf <vrf_name>
  router bgp <as_number>
  ip vrf <vrf_name>
  address-family <type> vrf <vrf_name>
  redistribute connected
end
```

Configure and Enable NEMO in APN Profile

Use this example to configure and enable NEMO in an APN profile.

```
configure
  context <context_name>
  apn <apn_name>
  permission nemo
  ip context-name <name>
  ip address pool name <pool_name>
end
```

Create a NEMO HA

Use this example to create a NEMO HA.

```
configure
context <context_name>
  ha-service <ha_service_name>
    mn-ha-spi spi-number <number> encrypted secret <enc_secret>
    authentication mn-aaa noauth
    encapsulation allow keyless-gre
    bind address <ip_address>
  end
```

Monitoring and Troubleshooting

This section provides information on CLI commands that are available for monitoring and troubleshooting of Network Mobility.

Monitor Protocol

When using the monitor protocol command, enable option 26 to see all NEMO messages.

Show Commands and/or Outputs

This section provides information about show CLI commands that are available in support of Network Mobility.

- **show ha-service all:** Use this command to view the information about the configured HA service to make sure that the service starts along with all the key parameters of the CLI configured for this service.



Note Use the following show command CLIs from the context where IP VRF configuration is done, in the following case the CLIs are for context egress.

Use the following commands to view the information about the prefix and routes assigned as shown in the following output.

```
show ip bgp vpnv4 vrf <vrf-name>:
Network      Next Hop    Metric  LocPrf  Weight  Path
*> 15.1.1.0/32  0.0.0.0    0              32768  ?
*> 15.1.1.1/32  0.0.0.0    0              32768  ?
*> 15.1.1.2/32  0.0.0.0    0              32768  ?
*> 15.1.1.3/32  0.0.0.0    0              32768  ?
*> 15.1.1.4/32  0.0.0.0    0              32768  ?
*> 15.1.1.5/32  0.0.0.0    0              32768  ?
*> 15.1.1.6/32  0.0.0.0    0              32768  ?
*> 15.1.1.7/32  0.0.0.0    0              32768  ?
*> 80.240.0.0/20 0.0.0.0    0              32768  ?
*> 192.168.232.0/24 31.100.101.1 0              0      2000 ?

show ip route vrf <vrf-name>:
Destination  Nexthop    Protocol  Prec  Cost  Interface
*15.1.1.0/32  0.0.0.0    connected  0     0     0
*15.1.1.1/32  0.0.0.0    connected  0     0     0
*15.1.1.2/32  0.0.0.0    connected  0     0     0
*15.1.1.3/32  0.0.0.0    connected  0     0     0
*15.1.1.4/32  0.0.0.0    connected  0     0     0
```

```

*15.1.1.5/32 0.0.0.0 connected 0 0
*15.1.1.6/32 0.0.0.0 connected 0 0
*15.1.1.7/32 0.0.0.0 connected 0 0
*80.240.0.0/20 0.0.0.0 connected 0 0 pool cust101-a
*192.168.232.0/24 31.100.101.1 bgp 20 0 19/1-sub101 (nhlfe-ix:8)

```

```
show mipha full all
```

```
MSID: -
```

```
Home Address: XX.XX.XX.XX HA Address: XXX.XXX.XXX.X
```

```
Total Prefix: 16 Multi-VRF: NO
```

```
VRF #1: vrf-cust101 CtxtID: 0x43 GRE: 0x0
```

```
15.1.1.0/32 15.1.1.1/32
```

```
15.1.1.2/32 15.1.1.3/32
```

```
15.1.1.4/32 15.1.1.5/32
```

```
15.1.1.6/32 15.1.1.7/32
```

```
15.1.1.8/32 15.1.1.9/32
```

```
15.1.1.10/32 15.1.1.11/32
```

```
15.1.1.12/32 15.1.1.13/32
```

```
15.1.1.14/32 15.1.1.15/32
```

```
Send NAI Extension in Revocation Message: NO
```

```
Binding #1: Care of Address: XX.XXX.X.XX
```

```
FA Address/Port: XX.XXX.X.XX/XXX
```

```
Lifetime: 00h01m15s Remaining Life: 00h00m26s
```

```
Reverse Tunneling: On Encapsulation Type: Keyless-GRE
```

```
GRE Key(Fwd): n/a IPSec Required: No
```

```
GRE Key(Rev): n/a
```

```
IPSec Ctrl Tunnel Estab.:No IPSec Data Tunnel Estab.: No
```

```
Revocation Negotiated: NO Rev I Bit Negotiated: NO
```

```
Colocated COA: YES NAT Detected: NO
```

```
MN-HA-Key-Present: TRUE MN-HA-SPI: 256
```

```
FA-HA-Key-Present: FALSE FA-HA-SPI: n/a
```

```
HA-RK-KEY-Present: FALSE HA-RK-SPI: n/a
```

```
HA-RK-Lifetime: n/a HA-RK-Remaining-Lifetime: n/a
```



CHAPTER 40

NEMO PMIPv6 Heartbeat on LMA

- [Feature Information, on page 805](#)
- [Feature Description, on page 806](#)
- [Monitoring and Troubleshooting the NEMO PMIPv6 Heartbeat on LMA, on page 807](#)

Feature Information

Summary Data

Status	New Functionality
Introduced-In Release	pre 21.2
Modified-In Release(s)	21.2
Applicable Product(s)	SAEGW
Applicable Platform(s)	ASR 5500
Default Setting	Disabled
Related CDETS ID(s)	CSCuv38787, CSCvd04014
Related Changes in This Release	NEMO-LMA Heartbeat (P-GW)
Related Documentation	Command Line Interface Reference P-GW Administration Guide SAEGW Administration Guide

Revision History



Important Revision history details are not provided for features introduced before release 21.2.

Revision Details	Release	Release Date
New in this release.	21.2	April 27, 2017

Feature Description

Proxy Mobile IPv6 (PMIPv6) is a network-based mobility management protocol to provide mobility without requiring the participation of the mobile node in any PMIPv6 mobility-related signaling. The core functional entities, Mobile Access Gateway (MAG), and the Local Mobility Anchor (LMA), set up tunnels dynamically to manage mobility for a mobile node.

In an earlier release, support was added for the standardized PMIPv6 protocol between the NEMO and an SAEGW running on the ASR 5500. This support included processing of IPv4 prefixes at NEMO-LMA with IPv4 transport. With this release, the support is extended, including Session Recovery and ICSR support, for the following functionalities:

- Processing (add/modify/delete) of IPv6 and IPv4v6 prefixes at NEMO-LMA with IPv4 transport.
- Processing (add/modify/delete) of IPv4, IPv6, and IPv4v6 prefixes at NEMO-LMA with IPv6 transport.
- Generation of UDR for base call containing NEMO IPv4, IPv6, or both IPv4 and IPv6 prefixes information for NEMO IPv4 transport only.
- Heart beat support for NEMO-LMA with IPv6 transport.

UDR Support

UDR with NEMO prefixes information is generated for the base call in the following cases for NEMO IPv4 transport:

- During initial NEMO call registration where UDR contains all the NEMO prefixes (IPv4, IPv6, or both IPv4 and IPv6), and number of prefixes.
- During renew/update of NEMO prefixes where UDR contains only the new NEMO prefixes (IPv4, IPv6, or both IPv4 and IPv6 present in renew request), and number of prefixes.
- During call cleanup:
 - If base call is cleared ahead of NEMO call, UDR with existing nemo prefixes is generated.
 - If NEMO call is cleared ahead of base call, UDR without prefixes is generated (as NEMO information is already deleted).

License Requirements

Use of NEMO requires that a valid license key be installed. Contact your Cisco account or Support representative for information on how to obtain a license.

Monitoring and Troubleshooting the NEMO PMIPv6 Heartbeat on LMA

The following sections describe commands available to monitor the feature.

Show Command(s) and/or Outputs

The outputs of the following commands are modified to display the IPv6 prefixes in support of the NEMO PMIPv6 Heartbeat on LMA feature.

show lma-service session full

The following is a sample display:

```
Session Type: Proxy MIPv6
IPv6 Traffic: Enabled
Total Prefix: 8
VRF #1: vrf1
1111:0:0:3::/64
1111:0:0:5::/64
1111:0:0:7::/64
1111:0:0:9::/64
Multi-VRF: NO
CtxtID: 0x42
GRE: 0x0
1111:0:0:4::/64
1111:0:0:6::/64
1111:0:0:8::/64
1111:0:0:a::/64
```

show subscribers debug-info username <username>

The following is a sample display:

```
NEMO Detail:
Peer bond: YES Peer Callid: 0098e4a1
Mode: Network Multi-VRF Enabled: NO
Total Prefixes: 8
VRF# VRF-Ctxt-ID OutboundGRE Accepted VRF Detail
1 0x42 0x0 YES vrf1
1111:0:0:3::/64 60778
1111:0:0:4::/64 60779
1111:0:0:5::/64 60780
1111:0:0:6::/64 60781
1111:0:0:7::/64 60782
1111:0:0:8::/64 60783
1111:0:0:9::/64 60784
1111:0:0:a::/64 60785
```

sessmgr NPU Flow Details:

Show Command(s) and/or Outputs



CHAPTER 41

Network Service Headers (NSH)

This chapter describes the following topics:

- [Feature Summary and Revision History, on page 809](#)
- [Feature Description, on page 810](#)
- [How It Works, on page 810](#)
- [Configuring Support for NSH Framework, on page 812](#)
- [Show Commands and Outputs, on page 819](#)

Feature Summary and Revision History

Summary Data

Applicable Product(s) or Functional Area	<ul style="list-style-type: none">• P-GW• SAEGW
Applicable Platform(s)	<ul style="list-style-type: none">• ASR 5500• VPC-DI• VPC-SI
Feature Default	Enabled - Always-on
Related Changes in This Release	Not Applicable
Related Documentation	<ul style="list-style-type: none">• <i>Command Line Interface Reference</i>• <i>P-GW Administration Guide</i>• <i>SAEGW Administration Guide</i>

Revision History

Revision Details	Release
In this release, NSH-based Traffic Identification with Traffic Steering is supported.	21.9
First introduced.	21.4

Feature Description

Network Services Headers (NSH), a new service chaining protocol, is added to the network traffic in a packet header to create a dedicated service plane that is independent of the underlying transport protocol. In general, NSH describes a sequence of service nodes that a packet is routed through before reaching the destination address. The NSH includes meta-data information about the packet and service chain in an IP packet. The NSH protocol addresses the growing requirement to deploy various services functions external to the gateway.

This feature introduces NSH protocol support for P-GW and SAEGW products and supports the following:

- Encoding and decoding of NSH format in the P-GW/SAEGW.
- Configurable parameters to be included for encoding in the variable header.
- NSH treatment for selective traffic based on configuration.
- Configuring the tag values for parameters present in the variable header.
- Selective configuration of policies for acting on the decode parameters received in the NSH.
- Configuring the intelligence of encoding the NSH information in every packet of a flow or only once per flow.
- NSH-based Traffic Identification with Traffic Steering.



Important In this release, selective encryption of parameters is not supported.

How It Works

This section describes the working of NSH protocol support in Cisco's P-GW/SAEGW products.

- **The Uplink Packet**

For the uplink packet, P-GW/SAEGW adds the NSH, if the flow matches the specified criteria. NSH has a variable length context header also.

Following call flow shows the NSH protocol support in the Cisco PGW/SAEGW products for an uplink packet.

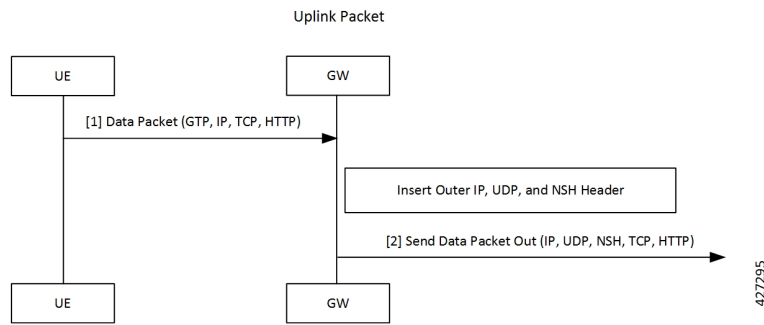

For an uplink packet, if the call flow matches the specified criteria, PGW or SAEGW adds the NSH header to the data packet. NSH header may have variable length context header, which can be encrypted if specified in the configuration.

• **The Downlink Packet**

For the downlink packet, P-GW/SAEGW processes and removes the NSH and applies policies based on the extracted NSH parameters.

Following call flow shows the NSH protocol support in the Cisco PGW/SAEGW products for a downlink packet.

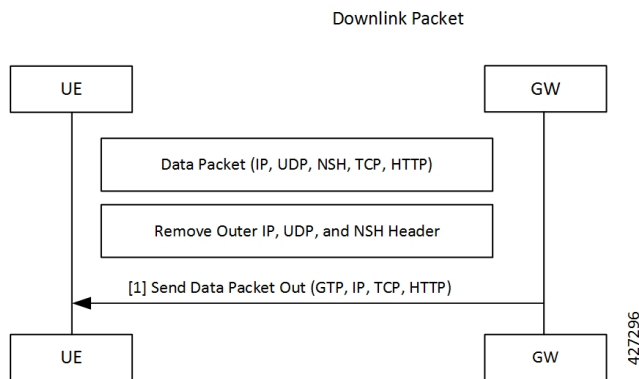

For a downlink packet, PGW or SAEGW processes and removes NSH header. Then, PGW or SAEGW apply policies based on the extracted NSH parameters.

- Source and destination IP address for the outer IP packet is taken from the inner IP packet.
- By default, NSH encapsulated packets use the port number 6633.



Configuring Support for NSH Framework

This section covers configuration steps used in this feature for adding support for NSH framework.

Charging Action Association

Service chain is associated to charging action in the following way:

```
configure
  active-charging service service_name
  charging-action charging_action_name
  service-chain service_chain_name
end
```

Notes:

- **charging-action:** Defines charging action.
charging_action_name: Specifies name of the charging action. This is entered as an alphanumeric string of 1 through 64 characters.
- **service-chain:** Defines service chain association.
service_chain_name: Specifies name of the service chain. This is entered as an alphanumeric string of 1 through 64 characters.

Service Chain Association

A new CLI command **nsh-format** is added to the **service-chain** command for service-chain association.

```

configure
  service-chain <service_chain_name>
    nsh-format <nsh_format_name>
  end

```

Notes:

- **service-chain**: Defines service chain association.
service_chain_name: Specifies name of the service chain. This is entered as an alphanumeric string of 1 through 64 characters.
- **nsh-format**: Associates NSH format with the service chain.

Service Scheme Association

A new CLI command **nsh-response-received** has been added to the **trigger** command to the ACS service scheme configuration mode.

```

configure
  active-charging service service_name
    service-scheme service_scheme_name
      [ no ] trigger { bearer-creation | flow-create | loc-update |
nsh-response-received | sess-setup }
    end

```

Notes:

- **service-scheme**: Enables the association of service-scheme based on subscriber class.
service_scheme_name: Specifies name of the service scheme. This is entered as an alphanumeric string of 1 through 64 characters.
- **no**: Disables the trigger action for the service-scheme.
- **trigger**: Specifies the trigger action for service-scheme.
- **bearer-creation**: Triggers for every new bearer.
- **flow-create**: Triggers for every new flow.
- **loc-update**: Triggers whenever location changes of the subscriber.
- **nsh-response-received**: Triggers on NSH response packet.
- **sess-setup**: Triggers at session setup.

NSH Configuration Mode

The Network Service Header (NSH) configuration mode is a sub-mode of the Global Configuration mode. This NSH mode is used to encode or decode NSH.

Exec > Global Configuration> Network Service Entity - IP Configuration

```
configure
nsh
end
```

Entering the above command sequence results in the following prompt:

```
[local]host_name(nsh)#
```

NSH Fields Configuration Mode

The NSH Fields configuration mode is a sub-mode of the NSH Configuration mode. This NSH Fields configuration mode is used to tag value to the NSH fields.

Exec > Global Configuration> Network Service Header > Network Service Header - Fields Configuration

```
configure
nsh
nsh-fields fields_name
end
```

Entering the above command sequence results in the following prompt:

```
[local]host_name(nsh-nshfields)#
```

tag-value

This new CLI command is added to the NSH Fields Configuration mode to associate a tag value to a NSH field.

```
configure
nsh
nsh-fields fields_name
tag-value tag_value { content-type | enterprise-id | imei | imsi |
msisdn | rating-group | rulebase | tdf-app-id }
end
```

Notes:

- **nsh-fields:** Defines NSH fields tag values.
fields_name: Specifies name of the *nsh-field*. This is entered as an alphanumeric string of 1 through 64 characters.
- **tag-value** Associates a tag to a field.
tag_value : Tag value for the NSH field.
- **content-type:** Specifies content type of payload.
- **enterprise-id:** Specifies the enterprise-ID to be sent in NSH context header.
- **imei:** Specifies IMEI of the subscriber.
- **imsi:** Specifies IMSI of the subscriber.
- **msisdn:** Specifies MSISDN of the subscriber.

- **rating-group**: Specifies rating-group applied for the traffic.
- **rulebase**: Specifies rule-base of the subscribers.
- **tdf-app-id**: Specifies TDF Application ID applied to the traffic.

NSH Format Configuration Mode

The NSH Format Configuration mode is a sub-mode of the NSH Configuration mode. This NSH Format mode is used to encode or decode NSH.

Exec > Global Configuration> Network Service Header > Network Service Header - Format

```
configure
nsh
nsh-format format_name
end
```

Entering the above command sequence results in the following prompt:

```
[local]host_name(nsh-nshformat)#
```

encode

This new CLI command is added to the NSH Format configuration mode. This command defines the NSH encoding fields to be associated with the NSH format.

```
configure
nsh
nsh-format format_name
encode nsh-fields fields_name
end
```

Notes:

- **nsh-format**: Defines format in NSH header.
format_name: Specifies name of the *NSH format*. This is entered as an alphanumeric string of 1 through 64 characters.
- **encode**: Associates nsh-fields for encoding.
- **nsh-fields**: Defines nsh fields tag value.
fields_name: Specifies name of the fields. This is entered as an alphanumeric string of 1 through 64 characters.

encoding-frequency

This command defines frequency of encoding the NSH fields to be associated with the NSH format.

```
configure
nsh
nsh-format format_name
```

```

    encoding-frequency { always | once-per-flow }
end

```

Notes:

- **encoding-frequency**: Defines frequency of encoding nsh-fields.
- **always**: Encodes nsh fields on every hit.
- **once-per-flow**: Encodes nsh fields once per flow.

decode

This command defines the NSH decoding fields to be associated with the NSH format.

```

configure
nsh
    nsh-format format_name
        decode nsh-fields fields_name
    end
end

```

Notes:

- **nsh-format**: Defines format in NSH header.
format_name: Specifies name of the *NSH format*. This is entered as an alphanumeric string of 1 through 64 characters.
- **decode**: Associates nsh-fields for decoding.
- **nsh-fields**: Defines nsh fields tag value.
fields_name: Specifies name of the fields. This is entered as an alphanumeric string of 1 through 64 characters.

Trigger Condition Configuration Mode Commands**content-type**

This command specifies the content type to be matched.

```

configure
    active-charging service service_name
        trigger-condition trigger_condition_name
            content-type { operator condition }
        end
end

```

Notes:

- **trigger-condition**: Defines ACS trigger conditions.
trigger_condition_name: Specifies name of the trigger condition. This is entered as an alphanumeric string of 1 through 64 characters.
- **content-type**: Specifies the content type.

- **operator** : Specifies how to match. Operator must be one of the following:
 - **!=**: not equals
 - **!contains**: not contains
 - **!ends-with**: not ends with
 - **!starts-with**: not starts with
 - **=**: equals
 - **contains**: contains
 - **ends-with**: ends with
 - **starts-with**: starts with
- **condition**: Specifies the condition to match. Condition must be one of the following:
 - FALSE
 - TRUE

tdf-app-id

This command specifies the identifier for application-based rules to be matched.

configure

```
active-charging service service_name
  trigger-condition trigger_condition_name
    tdf-app-id { operator condition }
  end
```

Notes:

- **trigger-condition**: Defines ACS trigger conditions.
 - trigger_condition_name*: Specifies name of the trigger condition. This is entered as an alphanumeric string of 1 through 64 characters.
- **tdf-app-id**: Specifies the identifier for application based rules.
- **operator condition**: Specifies how to match. Operator must be one of the following:
 - **!=**: not equals
 - **!contains**: not contains
 - **!ends-with**: not ends with
 - **!starts-with**: not starts with
 - **=**: equals
 - **contains**: contains
 - **ends-with**: ends with

- **starts-with**: starts with
- **condition**: Specifies the condition to match. Condition must be one of the following:
 - FALSE
 - TRUE

Sample Configuration for NSH Creation

The following is a sample configuration for this NSH service creation:

```

config
    nsh
        nsh-fields xyz
            tag-val 1 imei
            tag-val 2 imsi
        exit
        nsh-fields abc
            tag-val 4 content-type
        exit
        nsh-format format1
            encoding frequency always
            encode nsh-fields xyz
            decode nsh-fields abc
        exit
    exit
    traffic-steering
    appliance-group firewall
        nsh-format format1
        ip address 1.2.3.4
    #exit
#exit
service-chain sch1
    sfp direction uplink service-index 1 appliance firewall
#exit
exit
config
    active-charging service ACS
        trigger-action tal
            throttle-suppress
        exit
        trigger-condition tc1
            content-type contains text
        exit
        service-scheme schemel
            trigger nsh-response-received
            priority 1 trigger-condition tc1 trigger-action tal
        exit
    exit
    subs-class class1
        any-match = TRUE
    exit
    subscriber-base basel
        priority 1 subs-class class1 bind service-scheme schemel
    exit
    charging-action cal
        service-chain xyz
    exit

```

```

    exit
exit

```

Show Commands and Outputs

This section provides information regarding show commands and their outputs in support of the feature.

show nsh statistics

This command has been newly added in this release to display the nsh statistics. Following is the output when you execute this command:

```

Total Encap Successful           :           0
Total Decap Successful          :           0

Total Encap Failed              :           0
  Memory Allocation             :           0
  Config Error                  :           0
  Encryption Failed             :           0

Total Decap Failed              :           0
  Config Error                  :           0
  Base Header
    Invalid Length              :           0
    Unsupported Version         :           0
    Unsupported Next Protocol   :           0
    Next Protocol Mismatch     :           0
    Unsupported MD-Type         :           0
  Context Header
    Unsupported MD-Class        :           0
    Unsupported Type            :           0

OAM Packets
  Received                      :           0
  Dropped                      :           0

Unknown Context Header Type     :           0

```

show active-charging trigger-condition statistics

The output of this command includes the following field for this feature:

- NSH-Rsp-Rcvd

This field displays the matching of trigger condition based on NSH response.

■ show active-charging trigger-condition statistics



CHAPTER 42

Operator Policy

The proprietary concept of an operator policy, originally architected for the exclusive use of an SGSN, is non-standard and currently unique to the ASR 5500. This optional feature empowers the carrier with flexible control to manage functions that are not typically used in all applications and to determine the granularity of the implementation of any operator policy: to groups of incoming calls or to simply one single incoming call.

The following products support the use of the operator policy feature:

- MME (Mobility Management Entity - LTE)
- SGSN (Serving GPRS Support Node - 2G/3G/LTE)
- S-GW (Serving Gateway - LTE)

This document includes the following information:

- [What Operator Policy Can Do, on page 821](#)
- [The Operator Policy Feature in Detail, on page 822](#)
- [How It Works, on page 826](#)
- [Operator Policy Configuration, on page 826](#)
- [Verifying the Feature Configuration, on page 832](#)

What Operator Policy Can Do

Operator policy enables the operator to specify a policy with rules governing the services, facilities and privileges available to subscribers.

A Look at Operator Policy on an SGSN

The following is only a sampling of what working operator policies can control on an SGSN:

- APN information included in call activation messages are sometimes damaged, misspelled, missing. In such cases, the calls are rejected. The operator can ensure calls aren't rejected and configure a range of methods for handling APNs, including converting incoming APNs to preferred APNs and this control can be used in a focused fashion or defined to cover ranges of subscribers.
- In another example, it is not unusual for a blanket configuration to be implemented for all subscriber profiles stored in the HLR. This results in a waste of resources, such as the allocation of the default highest QoS setting for all subscribers. An operator policy provides the opportunity to address such issues by allowing fine-tuning of certain aspects of profiles fetched from HLRs and, if desired, overwrite QoS settings received from HLR.

A Look at Operator Policy on an S-GW

The S-GW operator policy provides mechanisms to fine tune the behavior for subsets of subscribers. It also can be used to control the behavior of visiting subscribers in roaming scenarios by enforcing roaming agreements and providing a measure of local protection against foreign subscribers.

The S-GW uses operator policy in the SGW service configuration to control the accounting mode. The default accounting mode is GTPP, but RADIUS/Diameter and none are options. The accounting mode value from the call control profile overrides the value configured in SGW service. If the accounting context is not configured in the call control profile, it is taken from SGW service. If the SGW service does not have the relevant configuration, the current context or default GTPP group is assumed.

The Operator Policy Feature in Detail

This flexible feature provides the operator with a range of control to manage the services, facilities and privileges available to subscribers.

Operator policy definitions can depend on factors such as (but not limited to):

- roaming agreements between operators,
- subscription restrictions for visiting or roaming subscribers,
- provisioning of defaults to override standard behavior.

These policies can override standard behaviors and provide mechanisms for an operator to circumvent the limitations of other infrastructure elements such as DNS servers and HLRs in 2G/3G networks.

By configuring the various components of an operator policy, the operator fine-tunes any desired restrictions or limitations needed to control call handling and this can be done for a group of callers within a defined IMSI range or per subscriber.

Re-Usable Components - Besides enhancing operator control via configuration, the operator policy feature minimizes configuration by drastically reducing the number of configuration lines needed. Operator policy maximizes configurations by breaking them into the following reusable components that can be shared across IMSI ranges or subscribers:

- call control profiles
- IMEI profiles (SGSN only)
- APN profiles
- APN remap tables
- operator policies
- IMSI ranges

Each of these components is configured via a separate configuration mode accessed through the Global Configuration mode.

Call Control Profile

A call control profile can be used by the operator to fine-tune desired functions, restrictions, requirements, and/or limitations needed for call management on a per-subscriber basis or for groups of callers across IMSI ranges. For example:

- setting access restriction cause codes for rejection messages
- enabling/disabling authentication for various functions such as attach and service requests

- enabling/disabling ciphering, encryption, and/or integrity algorithms
- enabling/disabling of packet temporary mobile subscriber identity (P-TMSI) signature allocation (SGSN only)
- enabling/disabling of zone code checking
- allocation/retention priority override behavior (SGSN only)
- enabling/disabling inter-RAT, 3G location area, and 4G tracking area handover restriction lists (MME and S-GW only)
- setting maximum bearers and PDNs per subscriber (MME and S-GW only)

Call control profiles are configured with commands in the Call Control Profile configuration mode. A single call control profile can be associated with multiple operator policies

For planning purposes, based on the system configuration, type of packet services cards, type of network (2G, 3G, 4G, LTE), and/or application configuration (single, combo, dual access), the following call control profile configuration rules should be considered:

- 1 (only one) - call control profile can be associated with an operator policy
- 1000 - maximum number of call control profiles per system (e.g., an SGSN).
- 15 - maximum number of equivalent PLMNs for 2G and 3G per call control profile
 - 15 - maximum number of equivalent PLMNs for 2G per ccprofile.
 - 15 - maximum number of supported equivalent PLMNs for 3G per ccprofile.
- 256 - maximum number of static SGSN addresses supported per PLMN
- 5 - maximum number of location area code lists supported per call control profile.
- 100 - maximum number of LACs per location area code list supported per call control profile.
- unlimited number of zone code lists can be configured per call control profile.
- 100 - maximum number of LACs allowed per zone code list per call control profile.
- 2 - maximum number of integrity algorithms for 3G per call control profile.
- 3 - maximum number of encryption algorithms for 3G per call control profile.

APN Profile

An APN profile groups a set of access point name (APN)-specific parameters that may be applicable to one or more APNs. When a subscriber requests an APN that has been identified in a selected operator policy, the parameter values configured in the associated APN profile will be applied.

For example:

- enable/disable a direct tunnel (DT) per APN. (SGSN)
- define charging characters for calls associated with a specific APN.
- identify a specific GGSN to be used for calls associated with a specific APN (SGSN).
- define various quality of service (QoS) parameters to be applied to calls associated with a specific APN.
- restrict or allow PDP context activation on the basis of access type for calls associated with a specific APN.

APN profiles are configured with commands in the APN Profile configuration mode. A single APN profile can be associated with multiple operator policies.

For planning purposes, based on the system configuration, type of packet processing cards and 2G, 3G, 4G, and/or dual access, the following APN profile configuration rules should be considered:

- 50 - maximum number of APN profiles that can be associated with an operator policy.

- 1000 - maximum number of APN profiles per system (e.g., an SGSN).
- 116 - maximum gateway addresses (GGSN addresses) that can be defined in a single APN profile.

IMEI-Profile (SGSN only)

The IMEI is a unique international mobile equipment identity number assigned by the manufacturer that is used by the network to identify valid devices. The IMEI has no relationship to the subscriber.

An IMEI profile group is a set of device-specific parameters that control SGSN behavior when one of various types of Requests is received from a UE within a specified IMEI range. These parameters control:

- Blacklisting devices
- Identifying a particular GGSN to be used for connections for specified devices
- Enabling/disabling direct tunnels to be used by devices

IMEI profiles are configured with commands in the IMEI Profile configuration mode. A single IMEI profile can be associated with multiple operator policies.

For planning purposes, based on the system configuration, type of packet processing cards, type of network (2G, 3G, 4G, LTE), and/or application configuration (single, combo, dual access), the following IMEI profile configuration rules should be considered:

- 10 - maximum number of IMEI ranges that can be associated with an operator policy.
- 1000 - maximum number of IMEI profiles per system (such as an SGSN).

APN Remap Table

APN remap tables allow an operator to override an APN specified by a user, or the APN selected during the normal APN selection procedure, as specified by 3GPP TS 23.060. This atypical level of control enables operators to deal with situations such as:

- An APN is provided in the Activation Request that does not match with any of the subscribed APNs either a different APN was entered or the APN could have been misspelled. In such situations, the SGSN would reject the Activation Request. It is possible to correct the APN, creating a valid name so that the Activation Request is not rejected.
- In some cases, an operator might want to force certain devices/users to use a specific APN. For example, all iPhone4 users may need to be directed to a specific APN. In such situations, the operator needs to be able to override the selected APN.

An APN remap table group is a set of APN-handling configurations that may be applicable to one or more subscribers. When a subscriber requests an APN that has been identified in a selected operator policy, the parameter values configured in the associated APN remap table will be applied. For example, an APN remap table allows configuration of the following:

- APN aliasing - maps incoming APN to a different APN based on partial string match (MME and SGSN) or matching charging characteristic (MME and SGSN).
- Wildcard APN - allows APN to be provided by the SGSN when wildcard subscription is present and the user has not requested an APN.
- Default APN - allows a configured default APN to be used when the requested APN cannot be used for example, the APN is not part of the HLR subscription. In 21.4 and later releases, the configuration to enable default APN on failure of DNS query is enhanced to support S4-SGSN. When wildcard APN is

received in subscription, the DNS request is tried with the MS requested APN and on failure of DNS, it is retried with the APN value configured in the APN remap table.

APN remap tables are configured with commands in the APN Remap Table configuration mode. A single APN remap table can be associated with multiple operator policies, but an operator policy can only be associated with a single APN remap table.

For planning purposes, based on the system configuration, type of packet processing cards, type of network (2G, 3G, 4G, LTE), and/or application configuration (single, combo, dual access), the following APN remap table configuration rules should be considered:

- 1 - maximum number of APN remap tables that can be associated with an operator policy.
- 1000 - maximum number of APN remap tables per system (such as an SGSN).
- 100 - maximum remap entries per APN remap table.

Operator Policies

The profiles and tables are created and defined within their own configuration modes to generate sets of rules and instructions that can be reused and assigned to multiple policies. An operator policy binds the various configuration components together. It associates APNs, with APN profiles, with an APN remap table, with a call control profile, and/or an IMEI profile (SGSN only) and associates all the components with filtering ranges of IMSIs.

In this manner, an operator policy manages the application of rules governing the services, facilities, and privileges available to subscribers.

Operator policies are configured and the associations are defined via the commands in the Operator Policy configuration mode.

The IMSI ranges are configured with the command in the SGSN-Global configuration mode.

For planning purposes, based on the system configuration, type of packet processing cards, type of network (2G, 3G, 4G, LTE), and/or application configuration (single, combo, dual access), the following operator policy configuration rules should be considered:

- 1 maximum number of call control profiles associated with a single operator policy.
- 1 maximum number of APN remap tables associated with a single operator policy.
- 10 maximum number of IMEI profiles associated with a single operator policy (SGSN only)
- 50 maximum number of APN profiles associated with a single operator policy.
- 1000 maximum number of operator policies per system (e.g., an SGSN) this number includes the single default operator policy.
- 1000 maximum number of IMSI ranges defined per system (e.g., an SGSN).



Important

SGSN operator policy configurations can be converted to enable them to work with an SGSN. Your Cisco Account Representative can accomplish this conversion for you.

IMSI Ranges

Ranges of international mobile subscriber identity (IMSI) numbers, the unique number identifying a subscriber, are associated with the operator policies and used as the initial filter to determine whether or not any operator policy would be applied to a call. The range configurations are defined by the MNC, MCC, a range of MSINs, and optionally the PLMN ID. The IMSI ranges must be associated with a specific operator policy.

IMSI ranges are defined differently for each product supporting the operator policy feature.

How It Works

The specific operator policy is selected on the basis of the subscriber's IMSI at attach time, and optionally the PLMN ID selected by the subscriber or the RAN node's PLMN ID. Unique, non-overlapping, IMSI + PLMN-ID ranges create call filters that distinguish among the configured operator policies.

The following flowchart maps out the logic applied for the selection of an operator policy:

Figure 126: Operator Policy Selection Logic

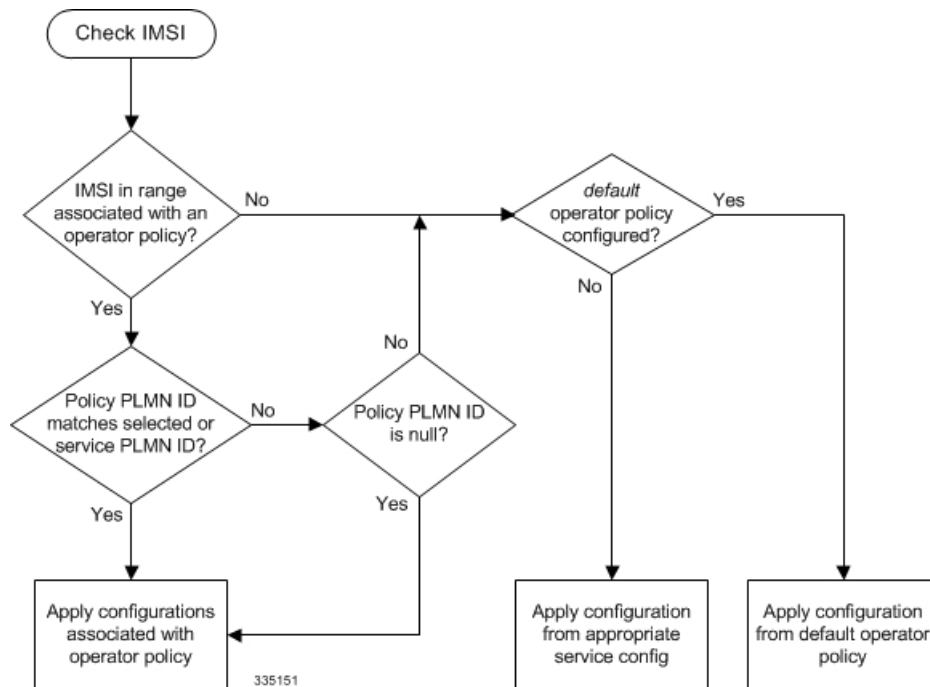

Operator Policy Configuration

This section provides a high-level series of steps and the associated configuration examples to configure an operator policy. By configuring an operator policy, the operator fine-tunes any desired restrictions or limitations needed to control call handling per subscriber or for a group of callers within a defined IMSI range.

Most of the operator policy configuration components are common across the range of products supporting operator policy. Differences will be noted as they are encountered below.



Important This section provides a minimum instruction set to implement operator policy. For this feature to be operational, you must first have completed the system-level configuration as described in the *System Administration Guide* and the service configuration described in your product's administration guide.

The components can be configured in any order. This example begins with the call control profile:

-
- Step 1** Create and configure a call control profile, by applying the example configuration presented in the Call Control Profile Configuration section.
 - Step 2** Create and configure an APN profile, by applying the example configuration presented in the APN Profile Configuration section.
 - Note** It is not necessary to configure both an APN profile and an IMEI profile. You can associate either type of profile with a policy. It is also possible to associate one or more APN profiles with an IMEI profile for an operator policy (SGSN only).
 - Step 3** Create and configure an IMEI profile by applying the example configuration presented in the *IMEI Profile Configuration* section (SGSN only).
 - Step 4** Create and configure an APN remap table by applying the example configuration presented in the *APN Remap Table Configuration* section.
 - Step 5** Create and configure an operator policy by applying the example configuration presented in the *Operator Policy Configuration* section.
 - Step 6** Configure an IMSI range by selecting and applying the appropriate product-specific example configuration presented in the *IMSI Range Configuration* sections below.
 - Step 7** Associate the configured operator policy components with each other and a network service by applying the example configuration in the *Operator Policy Component Associations* section.
 - Step 8** Save your configuration to flash memory, an external memory device, and/or a network location using the Exec mode command **save configuration**. For additional information on how to verify and save configuration files, refer to the *System Administration Guide* .
 - Step 9** Verify the configuration for each component separately by following the instructions provided in the *Verifying the Feature Configuration* section of this chapter.
-

Call Control Profile Configuration

This section provides the configuration example to create a call control profile and enter the configuration mode.

Use the call control profile commands to define call handling rules that will be applied via an operator policy. Only one call control profile can be associated with an operator policy, so it is necessary to use (and repeat as necessary) the range of commands in this mode to ensure call-handling is sufficiently managed.

Configuring the Call Control Profile for an SGSN

The example below includes some of the more commonly configured call control profile parameters with sample variables that you will replace with your own values.

```

configure
  call-control-profile profile_name>
    attach allow access-type umts location-area-list instance list_id
    authenticate attach
    location-area-list instance instance area-code area_code
    sgsn-number E164_number
  end

```

Notes:

- Refer to the *Call Control Profile Configuration Mode* chapter in the *Command Line Interface Reference* for command details and variable options.
- This profile will only become valid when it is associated with an operator policy.

Configuring the Call Control Profile for an MME or S-GW

The example below includes some of the more commonly configured call control profile parameters with sample variables that you will replace with your own values.

```

configure
  call-control-profile profile_name
    associate hss-peer-service service_name s6a-interface
    attach imei-query-type imei verify-equipment-identity
    authenticate attach
    dns-pgw context mme_context_name
    dns-sgw context mme_context_name
  end

```

Notes:

- Refer to the *Call Control Profile Configuration Mode* chapter in the *Command Line Interface Reference* for command details and variable options.
- This profile will only become valid when it is associated with an operator policy.

APN Profile Configuration

This section provides the configuration example to create an APN profile and enter the apn-profile configuration mode.

Use the **apn-profile** commands to define how calls are to be handled when the requests include an APN. More than one APN profile can be associated with an operator policy.

The example below includes some of the more commonly configured profile parameters with sample variables that you will replace with your own values.

```

configure
  apn-profile profile_name
    gateway-address 209.165.200.227 priority 1 (SGSN only)
    direct-tunnel not-permitted-by-ggsn (SGSN only)
    idle-mode-acl ipv4 access-group station7 (S-GW only)
  end

```

Notes:

- All of the parameter defining commands in this mode are product-specific. Refer to the *APN Profile Configuration Mode* chapter in the *Command Line Interface Reference* for command details and variable options.
- This profile will only become valid when it is associated with an operator policy.

IMEI Profile Configuration - SGSN only

This section provides the configuration example to create an IMEI profile and enter the imei-profile configuration mode.

Use the **imei-profile** commands to define how calls are to be handled when the requests include an IMEI in the defined IMEI range. More than one IMEI profile can be associated with an operator policy.

The example below includes some of the more commonly configured profile parameters with sample variables that you will replace with your own values.

configure

```
imei-profile profile_name
ggsn-address 211.211.123.3
direct-tunnel not-permitted-by-ggsn (SGSN only)
associate apn-remap-table remap1
end
```

Notes:

- It is optional to configure an IMEI profile. An operator policy can include IMEI profiles and/or APN profiles.
- This profile will only become valid when it is associated with an operator policy.

APN Remap Table Configuration

This section provides the configuration example to create an APN remap table and enter the apn-remap-table configuration mode.

Use the **apn-remap-table** commands to define how APNs are to be handled when the requests either do or do not include an APN.

The example below includes some of the more commonly configured profile parameters with sample variables that you will replace with your own values.

configure

```
apn-remap-table table_name
apn-selection-default first-in-subscription
wildcard-apn pdp-type ipv4 network-identifier apn_net_id
blank-apn network-identifier apn_net_id (SGSN only)
end
```

Notes:

- The **apn-selection-default first-in-subscription** command is used for APN redirection to provide "guaranteed connection" in instances where the UE-requested APN does not match the default APN or is missing completely. In this example, the first APN matching the PDP type in the subscription is used. The first-in-selection keyword is an MME feature only.

- Some of the commands represented in the example above are common and some are product-specific. Refer to the *APN-Remap-Table Configuration Mode* chapter in the *Command Line Interface Reference* for command details and variable options.
- This profile will only become valid when it is associated with an operator policy.

Operator Policy Configuration

This section provides the configuration example to create an operator policy and enter the operator policy configuration mode.

Use the commands in this mode to associate profiles with the policy, to define and associate APNs with the policy, and to define and associate IMEI ranges. Note: IMEI ranges are supported for SGSN only.

The example below includes sample variable that you will replace with your own values.

configure

```

operator-policy policy_name
  associate call-control-profile profile_name
  apn network-identifier apn-net-id_1 apn-profile apn_profile_name_1
  apn network-identifier apn-net-id_2 apn-profile apn_profile_name_1
  imei range <imei_number to imei_number> imei-profile name profile_name
  associate apn-remap-table table_name
end

```

Notes:

- Refer to the *Operator-Policy Configuration Mode* chapter in the *Command Line Interface Reference* for command details and variable options.
- This policy will only become valid when it is associated with one or more IMSI ranges (SGSN) or subscriber maps (MME and S-GW).

IMSI Range Configuration

This section provides IMSI range configuration examples for each of the products that support operator policy functionality.

Configuring IMSI Ranges on the MME or S-GW

IMSI ranges on an MME or S-GW are configured in the Subscriber Map Configuration Mode. Use the following example to configure IMSI ranges on an MME or S-GW:

configure

```

subscriber-map name
  lte-policy
    precedence number match-criteria imsi mcc mcc_number mnc mnc_number msin
  first start_range last end_range operator-policy-name policy_name
end

```

Notes:

- The precedence number specifies the order in which the subscriber map is used. 1 has the highest precedence.
- The operator policy name identifies the operator policy that will be used for subscribers that match the IMSI criteria and fall into the MSIN range.

Configuring IMSI Ranges on the SGSN

The example below is specific to the SGSN and includes sample variables that you will replace with your own values.

```
configure
sgsn-global
imsi-range mcc 311 mnc 411 operator-policy oppolicy1
imsi-range mcc 312 mnc 412 operator-policy oppolicy2
imsi-range mcc 313 mnc 413 operator-policy oppolicy3
imsi-range mcc 314 mnc 414 operator-policy oppolicy4
imsi-range mcc 315 mnc 415 operator-policy oppolicy5
end
```

Notes:

- Operator policies are not valid until IMSI ranges are associated with them.

Associating Operator Policy Components on the MME

After configuring the various components of an operator policy, each component must be associated with the other components and, ultimately, with a network service.

The MME service associates itself with a subscriber map. From the subscriber map, which also contains the IMSI ranges, operator policies are accessed. From the operator policy, APN remap tables and call control profiles are accessed.

Use the following example to configure operator policy component associations:

```
configure
operator-policy name
  associate apn-remap-table table_name
  associate call-control-profile profile_name
exit
lte-policy
subscriber-map name
  precedence match-criteria all operator-policy-name policy_name
  exit
exit
context mme_context_name
mme-service mme_svc_name
  associate subscriber-map name
end
```

Notes:

- The **precedence** command in the subscriber map mode has other **match-criteria** types. The **all** type is used in this example.

Configuring Accounting Mode for S-GW

The **accounting mode** command configures the mode to be used for the S-GW service for accounting, either **GTPP** (default), **RADIUS/Diameter**, or **None**.

Use the following example to change the S-GW accounting mode from GTPP (the default) to RADIUS/Diameter:

```
configure
context sgw_context_name
  sgw-service sgw_srv_name
    accounting mode radius-diameter
  end
```

Notes:

- An accounting mode configured for the call control profile will override this setting.

Verifying the Feature Configuration

This section explains how to display the configurations after saving them in a .cfg file as described in the *System Administration Guide*.



Important All commands listed here are under Exec mode. Not all commands are available on all platforms.

Verify that the operator policy has been created and that required profiles have been associated and configured properly by entering the following command in Exec Mode:

```
show operator-policy full name oppolicy1
```

The output of this command displays the entire configuration for the operator policy configuration.

```
show operator-policy full name oppolicy1
Operator Policy Name = oppolicy1
Call Control Profile Name           : ccprofile1
  Validity                          : Valid
APN Remap Table Name                : remapl
  Validity                          : Valid
IMEI Range 711919739                to 711919777
  IMEI Profile Name                  : imeiprof1
    Include/Exclude                  : Include
    Validity                         : Valid
APN NI homers1
  APN Profile Name                   : apn-profile1
  Validity                           : Valid
```

Notes:

- If the profile name is shown as "Valid", the profile has actually been created and associated with the policy. If the Profile name is shown as "Invalid", the profile has not been created/configured.
- If there is a valid call control profile, a valid APN profile and/or valid IMEI profile, and a valid APN remap table, the operator policy is valid and complete if the IMSI range has been defined and associated.



CHAPTER 43

Overcharging Protection Support

This chapter describes the Overcharging Protection Support feature and explains how it is configured. The product administration guides provide examples and procedures for configuration of basic services on the system. It is recommended that you select the configuration example that best meets your service model and configure the required elements for that model, as described in the *P-GW Administration Guide*, the *S-GW Administration Guide*, or the *SAEGW Administration Guide* before using the procedures in this chapter.

This chapter includes the following sections:

- [Overcharging Protection Feature Overview, on page 833](#)
- [License, on page 834](#)
- [Configuring Overcharging Protection Feature, on page 834](#)
- [Monitoring and Troubleshooting , on page 836](#)

Overcharging Protection Feature Overview

Overcharging Protection helps in avoiding charging the subscribers for dropped downlink packets while the UE is in idle mode. In some countries, it is a regulatory requirement to avoid such overcharging, so it becomes a mandatory feature for operators in such countries. Overall, this feature helps ensure subscriber are not overcharged while the subscriber is in idle mode.



Important This feature is supported on the P-GW, and S-GW. Overcharging Protection is supported on the SAEGW only if the SAEGW is configured for Pure P or Pure S functionality.

P-GW will never be aware of UE state (idle or connected mode). Charging for downlink data is applicable at P-GW, even when UE is in idle mode. Downlink data for UE may be dropped at S-GW when UE is in idle mode due to buffer overflow or delay in paging. Thus, P-GW will charge the subscriber for the dropped packets, which isn't desired. To address this problem, with Overcharging Protection feature enabled, S-GW will inform P-GW to stop or resume charging based on packets dropped at S-GW and transition of UE from idle to active state.

If the S-GW supports the Overcharging Protection feature, then it will send a CSReq with the PDN Pause Support Indication flag set to 1 in an Indication IE to the P-GW.

If the P-GW supports the Overcharging Protection feature then it will send a CSRsp with the PDN Pause Support Indication flag set to 1 in Indication IE and/or private extension IE to the S-GW.

Once the criterion to signal "stop charging" is met, S-GW will send Modify Bearer Request (MBReq) to P-GW. MBReq would be sent for the PDN to specify which packets will be dropped at S-GW. The MBReq will have an indication IE and/or a new private extension IE to send "stop charging" and "start charging" indication to P-GW. For Pause/Start Charging procedure (S-GW sends MBReq), MBRes from P-GW will have indication and/or private extension IE with Overcharging Protection information.

When the MBReq with stop charging is received from a S-GW for a PDN, P-GW will stop charging for downlink packets but will continue sending the packets to S-GW.

P-GW will resume charging downlink packets when either of these conditions is met:

- When the S-GW (which had earlier sent "stop charging" in MBReq) sends "start charging" in MBReq.
- When the S-GW changes (which indicates that maybe UE has relocated to new S-GW).

This feature aligns with the 3GPP TS 29.274: 3GPP Evolved Packet System (EPS); Evolved General Packet Radio Service (GPRS) Tunneling Protocol for Control plane (GTPv2-C) specification.



Important When Overcharging Protection feature is configured at both P-GW service and APN, configuration at APN takes priority.

License

Overcharging Protection is a license enabled feature and a new license key has been introduced for Overcharging Protection for P-GW functionality.



Important Contact your Cisco account representative for information on how to obtain a license.

Configuring Overcharging Protection Feature

This section describes how to configure overcharging protection support on the P-GW and S-GW.

Configuring Overcharging Support on the P-GW

This command enables overcharge protection for APNs controlled by this APN profile and configures overcharging protection by temporarily not charging during loss of radio coverage. Each overcharging protection option is a standalone configuration and it does not override the previous option set, if any. Use this command to specify P-GW to pause charging on abnormal-s1-release, DDN failure notification, or if the number of packets or bytes dropped exceeds the configured limit.



Important This configuration sequence is valid for the P-GW only.

```
configure
  apn-profile apn_profile_name
```

```

overcharge-protection { abnormal-s1-release | ddn-failure |
drop-limit drop_limit_value { packets | bytes } }
[ remove ] overcharge-protection { abnormal-s1-release | ddn-failure
| drop-limit }
end

```

Notes:

- **remove:**
Removes the specified configuration.
- **abnormal-s1-release:**
(for future use) If overcharging protection is enabled for abnormal-s1-release, S-GW would send MBR to pause charging at P-GW if Abnormal Release of Radio Link signal occurs from MME.
- **ddn-failure:**
If overcharging protection is enabled for ddn-failure message, MBR would be sent to P-GW to pause charging upon receiving DDN failure from MME/S4-SGSN.
- **drop-limit drop_limit_value { packets | bytes } }**
Send MBR to pause charging at P-GW if specified number of packets/bytes is dropped for a PDN connection.
drop_limit_value is an integer from 1 through 99999.
 - **packets:** Configures drop-limit in packets.
 - **bytes:** Configures drop-limit in bytes.

Configuring Overcharging Support on the S-GW

The following configuration is required for overcharging support on the S-GW:

```

configure
context context_name
egtp-service service_name
gtpc private-extension overcharge-protection
end

```

Notes:

- Enabling this command indicates that the S-GW has to interact with a release 15 P-GW for the overcharging protection feature which does not support 3GPP TS 29.274 Release 12 – *3GPP Evolved Packet System (EPS); Evolved General Packet Radio Service (GPRS) Tunneling Protocol for Control plane (GTPv2-C); Stage 3*.
- When the **gtpc private-extension overcharge-protection** command is configured, the S-GW includes a Private Extension in the Create Session Request (CSReq) and Modify Bearer Request (MBReq) messages.
- Whenever a P-GW receives a CSReq with an Indication IE with the PDN Pause Support Indication flag set to 1, it responds only with an Indication IE.
- When a CSReq does not have an Indication IE with the PDN Pause Support Indication flag set to 1, but the P-GW supports Overcharging Protection, then it responds with both an Indication and Private Extension IE.

Monitoring and Troubleshooting

P-GW Schema

The following bulk statistics have been added to the P-GW schema for Overcharging Protection:

For descriptions of these variables, see the *Statistics and Counters Reference* guide.

- sessstat-ovrchrgprtctn-uplpktddrop
- sessstat-ovrchrgprtctn-uplkbbytedrop
- sessstat-ovrchrgprtctn-dnlpktddrop
- sessstat-ovrchrgprtctn-dnlkbbytedrop

show apn statistics all

The following counters display overcharging protection stats for this APN:

- UL Ovrchrg Prtctn byte drop
- UL Ovrchrg Prtctn pkt drop
- DL Ovrchrg Prtctn byte drop
- DL Ovrchrg Prtctn pkt drop

show pgw-service all

The following field display configuration information for Overcharging Protection on this P-GW service:

- EGTP Overcharge Protection

show pgw-service statistics all

The following counters display Overcharging Protection for this P-GW node:

- Drops Due To Overcharge Protection
 - Packets
 - Bytes

show sgw-service statistics name <sgw_service_name>

The output of this command shows the total number of PDNs where charging was paused:

- PDNs Total:
 - Paused Charging: <Total number of PDNs where charging was paused>

show subscribers full

The following counters display Overcharging Protection for all subscribers:

- in packet dropped overcharge protection
- in bytes dropped overcharge protection
- out packet dropped overcharge protection
- out bytes dropped overcharge protection

**Important**

When a session is in overcharge protection state, not all the downlink packets will be dropped; however, downlink packets will be rate limited. Current configuration allows one downlink packet per minute towards S-GW without charging it, if any downlink packets come to P-GW. P-GW will not generate any packets of its own.; separate debug stats have been added for P-GW.

show subscribers pgw-only full all

The following field and counters display Overcharging Protection:

- Bearer State
 - in packet dropped overcharge protection
 - in bytes dropped overcharge protection
 - out packet dropped overcharge protection
 - out bytes dropped overcharge protection

show subscribers summary

The following counters display overcharging protection for all subscribers:

- in bytes dropped ovrchrgPtn
- in packet dropped ovrchrgPtn
- out bytes dropped ovrchrgPtn
- out packet dropped ovrchrgPtn

**Important**

When a session is in overcharge protection state, not all the downlink packets will be dropped; however, downlink packets will be rate limited. Current configuration allows one downlink packet per minute towards S-GW without charging it, if any downlink packets come to P-GW. P-GW will not generate any packets of its own; separate debug stats have been added for P-GW.

show subscribers summary



CHAPTER 44

Paging Policy Differentiation

This chapter describes the Paging Policy Differentiation feature and explains how it is configured. The product administration guides provide examples and procedures for configuration of basic services on the system. It is recommended that you select the configuration example that best meets your service model and configure the required elements for that model, as described in the *P-GW Administration Guide*, the *S-GW Administration Guide*, or the *SAEGW Administration Guide* before using the procedures in this chapter.

This chapter includes the following sections:

- [Feature Description, on page 839](#)
- [How It Works, on page 840](#)
- [Configuring Paging Policy Differentiation Feature, on page 841](#)
- [Monitoring and Troubleshooting Paging Policy Differentiation, on page 842](#)

Feature Description

S-GW/P-GW provide configuration control to change the DSCP value of the user-datagram packet and outer IP packet (GTP-U tunnel IP header). DSCP marking is done at various levels depending on the configuration. When the Paging Policy Differentiation (PPD) feature is enabled, however, the user-datagram packet DSCP (tunneled IP packet) marking does not change.

Currently, standards specify QCI to DSCP marking of outer GTP-U header only. All configurations present at ECS, P-GW, and S-GW to change the user-datagram packet DSCP value are non-standard. The standards-based PPD feature dictates that P-CSCF or similar Gi entity marks the DSCP of user-datagram packet. This user-datagram packet DSCP value is sent in DDN message by S-GW to MME/S4-SGSN. MME/S4-SGSN uses this DSCP value to give paging priority.



Important P-GW and S-GW should apply the PPD feature for both Default and Dedicated bearers. As per the specifications, P-GW transparently passes the user-datagram packet towards S-GW. This means, if PPD feature is enabled, operator can't apply different behavior for Default and Dedicated bearers.

Relationships

Since P-GW/S-GW support non-standard based DSCP marking, there is a conflict when both standard based PPD feature and non-standard based user-datagram packet DSCP configuration is enabled. To avoid this conflict:

- APN and service level configuration is ignored if PPD feature is enabled.
- S-GW/P-GW can alter the outer GTP-U header DSCP value, even if PPD feature is enabled.
- User-datagram packet DSCP value is unaltered by ECS, P-GW, and S-GW if PPD feature is enabled.
- At P-GW, APN-level configuration is added to enable/disable the PPD feature.
- At S-GW, service-level configuration is added to enable/disable the PPD feature. This is to send DSCP in Paging and Service Information IE of all the DDN messages triggered by either IMS-PDN or Internet-PDN, etc.



Important It is up to MME/S4-SGSN to use the Paging and Service Information IE of DDN message.

- Separate Paging feature and PPD feature co-exist in system. That means, if both features are enabled, both Paging and Service Information IE and Separate-paging IE are sent in DDN.
- Currently on P-GW, the DSCP configuration is getting applied at sub-session level during call setup time. So, when the PPD CLI is enabled for P-GW, it is applicable for new calls.
- Currently on S-GW, the DSCP configuration is getting applied at S-GW service level. So, when PPD CLI is enabled in S-GW service, it is applicable for both new and existing calls.
- Once the PPD CLI is enabled, it exists even after Session Recovery and ICSR switch over.
- The Paging and Service Information IE is used to carry per bearer paging and service information.

License

PPD is a license enabled feature. S-GW Paging Profile license key is required to enable PPD functionality for P-GW, S-GW, and SAEGW.



Important Contact your Cisco account representative for information on how to obtain a license.

How It Works

Architecture

S-GW

When S-GW supports the PPD feature, it shall include new Paging and Service Information IE in the Downlink Data Notification message triggered by the arrival of downlink data packets at the S-GW. The Paging Policy Indication value within this IE will contain the value of the DSCP in TOS (IPv4) or TC (IPv6) information received in the IP payload of the GTP-U packet from the P-GW.

At S-GW, service-level configuration enables/disables the PPD feature. Once the PPD is configured, the feature is enabled and applicable for both existing and new calls.

P-GW

User-datagram packet DSCP value is unaltered by P-GW for downlink data. The PPD feature is supported only for S5/S8 interface. For all Handoff scenarios from other interface to S5/S8 interface, the PPD feature will get enabled if APN had it during its call setup time at that interface.

At P-GW, APN-level configuration enables/disables the PPD feature. If PPD feature is enabled for the call and handoff happens from S5/S8 interface to any other interface, PPD feature should get disabled. Now, if handoff happens and this call will come back to S5/S8 interface, PPD feature should become enabled.

SAEGW

To support PPD feature in SAEGW, both S-GW and P-GW configuration is required.

Relationships to Other Features

- The PPD feature is license controlled under the license for S-GW Paging Profile. Once the license is enabled, both features co-exist together and work independently. That means, DDN message might carry both DSCP marking specified by PPD feature and Priority DDN value specified by S-GW Paging Profile feature.
- At S-GW, the user-datagram packet DSCP value is used to send in DDN. S-GW can't change the DSCP, as per the local configuration (APN profile or service level). At eNodeB, the scheduling of the packet is based on the QCI instead of DSCP, however, any EPC node should not change/modify the inner DSCP value.
- If the PPD feature is enabled, none of the EPS nodes should change the user-datagram packet DSCP value. Therefore, ECS should avoid overwriting DSCP value of user-datagram packet when PPD is enabled.

Standards Compliance

The PPD functionality complies with the following standards:

- 29.274, CR-1565, "Paging Policy Indication in Downlink Data Notification Message"
- 23.401, CR-2731 "Paging policy differentiation for IMS voice"

Configuring Paging Policy Differentiation Feature

For the PPD feature to work, it must be enabled for P-GW and S-GW.

Both P-GW and S-GW services apply PPD configuration independently. Therefore, for any downlink data packet from an APN, there could be a case where P-GW does not have PPD configuration but S-GW has PPD configuration. To avoid such a conflict, you must configure the PPD functionality on both P-GW (APN level granularity) and S-GW (service level granularity).

Configuration

The following CLI commands are used to manage the functionality for the PPD feature.

Enabling on P-GW

The following command enables the PPD feature on P-GW at APN level.

```

configure
  context context_name
    apn apn_name
      paging-policy-differentiation
    end

```

Enabling on S-GW

The following command enables the PPD feature on S-GW at service level.

```

configure
  context context_name
    sgw-service service_name
      paging-policy-differentiation
    end

```

Notes:

- This is to send DSCP in Paging and Service Information IE of all the DDN messages triggered by either IMS-PDN or Internet-PDN, etc.
- It is up to MME/S4-SGSN to use the Paging and Service Information IE of DDN message.
- If PPD feature is enabled at S-GW service, it is applicable for all calls irrespective of the APN profiles.

Disabling on P-GW

The following command disables the PPD feature on P-GW at APN level.

```

configure
  context context_name
    apn apn_name
      no paging-policy-differentiation
    end

```

Disabling on S-GW

The following command disables the PPD feature on S-GW at service level.

```

configure
  context context_name
    sgw-service service_name
      no paging-policy-differentiation
    end

```

Monitoring and Troubleshooting Paging Policy Differentiation

This section includes show commands in support of the PPD feature.

P-GW Show Commands

This section provides information regarding P-GW show commands and/or their outputs in support of the PPD feature.

show apn name <apn_name>

The following counter has been added to display PPD functionality.

```
Paging Policy Differentiation : Enabled
```

show subscribers pgw-only full all

The following counter has been added to display PPD functionality.

```
Paging Policy Differentiation : Enabled
```

SAEGW Show Commands

This section provides information regarding SAEGW show commands and/or their outputs in support of the PPD feature.

show subscribers saegw-only full all

The following counter has been added to display PPD functionality.

```
Paging Policy Differentiation : Enabled
```

S-GW Show Commands

This section provides information regarding S-GW show commands and/or their outputs in support of the PPD feature.

show sgw-service name <service_name>

The following counter has been added to display PPD functionality.

```
Paging Policy Differentiation : Enabled
```

```
show sgw-service name <service_name>
```



CHAPTER 45

P-GW Handoff KPIs for VoWiFi

- [P-GW Handoff KPIs for VoWiFi](#), on page 845

P-GW Handoff KPIs for VoWiFi

Feature Changes

Currently, there are no statistics to determine the number of new sessions started on a particular RAT technology and to monitor any inter-technology handovers per APN.

This feature introduces new session/handoff KPIs and P-GW VoWiFi specific KPIs to monitor the following:

- the number of new sessions started on a particular RAT technology
- the inter-technology handover per APN from and to all access technologies
- subscriber activity for network planning

The statistical information is maintained per APN and per P-GW/SAEGW service type. CLIs are applicable only for P-GW and SAEGW product. If eHRPD/PMIP/GGSN services are associated with a P-GW/SAEGW service, then counters related to these services will be reflected under P-GW/SAEGW service statistics CLI output.

Benefits

With the introduction of this feature, operators can have KPIs to monitor per RAT Initiated Sessions and Inter-technology handovers so that they can gauge 2G/3G/4G/WiFi/eHRPD coverage.

Operators can also:

- get statistics that report on:
 - new access technologies such as Wi-Fi that uses the ePDG
 - how a session has been initiated
 - how many handoffs have been done
- track subscriber activity in the network
- plan network accordingly

Limitations

- Initiated session statistics and handover statistics at APN-level are not maintained or incremented at demux due to memory and CPU constraints. During congestion scenarios, for example, some of the calls are rejected at the demux and so this count will not show up in the APN-level initiated session counter.
- Bulkstats for eHRPD and S2b-PMIP are not supported under SAEGW schema.

Monitoring and Troubleshooting P-GW Handoff KPIs for VoWiFi

The following section describes commands available to monitor P-GW Handoff KPIs for VoWiFi.

HandOff KPIS for VoWiFi Show Commands

The following section describes commands available to monitor Handoff KPIs for VoWiFi.

show apn statistics [all | name *apn_name* | verbose]

This command displays the following output.

```

Initiated Sessions per RAT Type:
  EUTRAN:    0    UTRAN:    0
  GERAN:    0    EHRPD:    0
  S2A GTP:  0    S2B GTP:   0
  S2B PMIP:  0

Inter Technology handover:
  GNGP-to-LTE handover:      LTE-to-GNGP handover:
    Attempted:    0          Attempted:    0
    Succeeded:    0          Succeeded:    0
    Failed:       0          Failed:       0

  GNGP-to-S4SGSN handover:   S4SGSN-to-GNGP handover:
    Attempted:    0          Attempted:    0
    Succeeded:    0          Succeeded:    0
    Failed:       0          Failed:       0

  S4SGSN-to-LTE handover:    LTE-to-S4SGSN handover:
    Attempted:    0          Attempted:    0
    Succeeded:    0          Succeeded:    0
    Failed:       0          Failed:       0

  LTE-to-eHRPD handover:     eHRPD-to-LTE handover:
    Attempted:    0          Attempted:    0
    Succeeded:    0          Succeeded:    0
    Failed:       0          Failed:       0

  LTE-to-S2bPMIP handover:   S2bPMIP-to-LTE handover:
    Attempted:    0          Attempted:    0
    Succeeded:    0          Succeeded:    0
    Failed:       0          Failed:       0

  eHRPD-to-S2bPMIP handover: S2bPMIP-to-eHRPD handover:
    Attempted:    0          Attempted:    0
    Succeeded:    0          Succeeded:    0
    Failed:       0          Failed:       0

  S2bGTP-to-LTE handover:    LTE-to-S2bGTP handover:
    Attempted:    0          Attempted:    0

```

```

Succeeded:      0      Succeeded:      0
Failed:         0      Failed:          0

S2bGTP-to-eHRPD handover:    eHRPD-to-S2bGTP handover:
  Attempted:      0      Attempted:      0
  Succeeded:      0      Succeeded:      0
  Failed:         0      Failed:         0

S2aGTP-to-LTE handover:      LTE-to-S2aGTP handover:
  Attempted:      0      Attempted:      0
  Succeeded:      0      Succeeded:      0
  Failed:         0      Failed:         0

```

show pgw-service statistics { all | name service_name }

The command displays the following output:

```

Initiated PDNs By RAT-Type:
  EUTRAN:         0      UTRAN:          0
  GERAN:         0      EHRPD:         0
  S2A GTP:       0      S2B GTP:       0
  S2B PMIP:      0

```

show saegw-service statistics { all | name service_name } function pgw

The command displays the following output:

```

Initiated PDNs By RAT-Type:
  EUTRAN:         0      UTRAN:          0
  GERAN:         0      EHRPD:         0
  S2A GTP:       0      S2B GTP:       0
  S2B PMIP:      0

```

Schema for P-GW Handoff KPIs for VoWifi

This section lists the schemas added in for the P-GW Handoff KPIs for VoWifi Feature.

APN Schema

Initiated Sessions Statistics Information based on RAT Technology:

The following new counters have been added to display the number of Initiated Sessions per RAT type, per Service/APN in this enhancement:

- initiated-eutran-sessions
- initiated-utran-sessions
- initiated-geran-sessions
- initiated-ehrpd-sessions
- initiated-s2a-gtp-sessions
- initiated-s2b-gtp-sessions
- initiated-s2b-pmip-sessions

Inter-Technology Handover Statistics:

The following new counters have been added to display the number of inter-technology handover statistics per APN/Service have been added in this enhancement:

- apn-handoverstat-gngptolteatt
- apn-handoverstat-gngptoltesucc
- apn-handoverstat-gngptoltefail
- apn-handoverstat-ltetogngpatt
- apn-handoverstat-ltetogngpsucc
- apn-handoverstat-ltetogngpfail
- apn-handoverstat-gngptos4sgsnatt
- apn-handoverstat-gngptos4sgsnsucc
- apn-handoverstat-gngptos4sgsnfail
- apn-handoverstat-s4sgsntogngpatt
- apn-handoverstat-s4sgsntogngpsucc
- apn-handoverstat-s4sgsntogngpfail
- apn-handoverstat-s4sgsntolteatt
- apn-handoverstat-s4sgsntoltesucc
- apn-handoverstat-s4sgsntoltefail
- apn-handoverstat-ltetos4sgsnatt
- apn-handoverstat-ltetos4sgsnsucc
- apn-handoverstat-ltetos4sgsnfail
- apn-handoverstat-ltetoehrpatt
- apn-handoverstat-ltetoehrpdsucc
- apn-handoverstat-ltetoehrpfail
- apn-handoverstat-ehrpdtolteatt
- apn-handoverstat-ehrpdtoltesucc
- apn-handoverstat-ehrpdtoltefail
- apn-handoverstat-ltetos2bpmipatt
- apn-handoverstat-ltetos2bpmipsucc
- apn-handoverstat-ltetos2bpmipfail
- apn-handoverstat-s2bpmiptolteatt
- apn-handoverstat-s2bpmiptoltesucc
- apn-handoverstat-s2bpmiptoltefail

- apn-handoverstat-ehrpdtos2bpmipatt
- apn-handoverstat-ehrpdtos2bpmipsucc
- apn-handoverstat-ehrpdtos2bpmipfail
- apn-handoverstat-s2bpmiptoehrpdtatt
- apn-handoverstat-s2bpmiptoehrpdsucc
- apn-handoverstat-s2bpmiptoehrpdfail
- apn-handoverstat-s2bgtpolteatt
- apn-handoverstat-s2bgtpoltesucc
- apn-handoverstat-s2bgtpoltefail
- apn-handoverstat-ltetos2bgtpatt
- apn-handoverstat-ltetos2bgtpsucc
- apn-handoverstat-ltetos2bgtpfail
- apn-handoverstat-s2bgtpoehrpdtatt
- apn-handoverstat-s2bgtpoehrpdsucc
- apn-handoverstat-s2bgtpoehrpdfail
- apn-handoverstat-ehrpdtos2bgtpatt
- apn-handoverstat-ehrpdtos2bgtpsucc
- apn-handoverstat-ehrpdtos2bgtpfail
- apn-handoverstat-s2agtpolteatt
- apn-handoverstat-s2agtpoltesucc
- apn-handoverstat-s2agtpoltefail
- apn-handoverstat-ltetos2agtpatt
- apn-handoverstat-ltetos2agtpsucc
- apn-handoverstat-ltetos2agtpfail

P-GW Schema

Initiated Sessions Statistics Information based on RAT Technology: The following counters have been added to display the number of Initiated Sessions per RAT type, per Service /APN in this enhancement:

- ssssstat-rat-init-eutran
- ssssstat-rat-init-utran
- ssssstat-rat-init-geran
- ssssstat-rat-init-ehrpdt
- ssssstat-rat-init-s2a-gtp

- sessstat-rat-init-s2b-gtp
- sessstat-rat-init-s2b-pmip

SAEGW Schema

Initiated Sessions Statistics Information based on RAT Technology: The following counters have been added to display the number of Initiated Sessions per RAT type, per Service/APN in this enhancement:

- pgw-sessstat-pdn-rat-init-eutran
- pgw-sessstat-pdn-rat-init-utran
- pgw-sessstat-pdn-rat-init-geran
- pgw-sessstat-pdn-rat-init-s2a-gtp
- pgw-sessstat-pdn-rat-init-s2b-gtp



CHAPTER 46

Presence Reporting Area

This chapter describes the following topics:

- [Feature Summary and Revision History, on page 851](#)
- [Feature Description, on page 852](#)
- [How It Works, on page 852](#)
- [Multiple Presence Reporting Area, on page 855](#)
- [Configuring Presence Reporting Area, on page 856](#)
- [Monitoring and Troubleshooting, on page 857](#)

Feature Summary and Revision History

Summary Data

Applicable Product(s) or Functional Area	<ul style="list-style-type: none">• P-GW• SAEGW• S-GW
Applicable Platform(s)	ASR 5500
Feature Default	Disabled - Configuration Required
Related Changes in This Release	Not Applicable
Related Documentation	<ul style="list-style-type: none">• <i>Command Line Interface Reference</i>• <i>P-GW Administration Guide</i>• <i>SAEGW Administration Guide</i>• <i>S-GW Administration Guide</i>

Revision History

Revision Details	Release
First introduced.	21.4

Feature Description

This feature adds support for the Presence Reporting Area (PRA) functionality to comply with the 3GPP standards.

The Presence Reporting Area is an area defined within the 3GPP packet domain for reporting of UE presence within that area. This is required for policy control and in charging scenarios. In E-UTRAN, the PRA may consist in a set of neighbor or non-neighbor Tracking Areas, or eNBs or cells. There are two types of Presence Reporting Areas: "UE-dedicated Presence Reporting Areas" and "Core Network pre-configured Presence Reporting Areas" that apply to an MME pool.

This feature has the following highlights:

- This feature is supported for LTE/S4-SGSN related RAT-type. For any other RAT type, P-GW ignores PRA information received from the PCRF.
- Currently single PRA-ID is supported per session as specification compliance.
- Currently, in P-GW, core network pre-configured presence reporting area is supported.
- For ICSR to N-1 release, PRA feature is not supported.
- PRA-ID is not supported on CDR interface, that is, Gz, Gy and Rf.

How It Works

During an IP-CAN session, the PCRF determines whether the reports for change of the UE presence in the PRA are required for an IP-CAN session. This determination is made based on the subscriber's profile configuration and the supported AVP features. The parameter CNO-ULI is set for the same. If the reporting is required for the IP-CAN session, the PCRF provides Presence-Reporting-Area-Information AVP, which contains the PRA identifier within the Presence-Reporting-Area-Identifier AVP to the PCEF. For a UE-dedicated PRA, PCRF provides the list of elements consisting of the PRA within the Presence-Reporting-Area-Elements-List AVP to the PCEF. The PCRF might activate the reporting changes of the UE presence in the PRA by subscribing to the CHANGE_OF_UE_PRESENCE_IN_PRESENCE_REPORTING_AREA_REPORT event trigger at the PCEF at any time during the entire IP-CAN session.

When the UE enters or leaves the PRA, PCEF reports the CHANGE_OF_UE_PRESENCE_IN_PRESENCE_REPORTING_AREA_REPORT event. Also, the PCEF also reports the PRA status within the Presence-Reporting-Area-Status AVP and PRA identifier within Presence-Reporting-Area-Identifier AVP included in Presence-Area-Information AVP.

Following table describes the scenario and its associated behavior:

Scenario	Behavior
When PCRF sends a new PRA ID different than the initial call setup.	<ul style="list-style-type: none"> • P-GW receives the new PRA ID during the initial call setup and stores the PRA ID information. • In RAR, the PRA_EVENT_TRIGGER is registered. • P-GW send PRA_ACTION PRA ID="A", ACTION=start. • In CCA-U, a new PRA ID is received. • P-GW stores new PRA ID information • P-GW sends PRA_ACTION PRA ID = "B", Action=start but does not send Action=stop for the earlier PRA. <p>Important Ideally, in above condition, PCRF disables the event triggers first and sends a new PRA-ID=B and enables the event trigger in subsequent message.</p>
When PCRF sends a new PRA ID which is same as the initial call setup.	PRA ID does not send any PRA Action toward S-GW and P-GW ignores this.
PRA ID Decode Behavior	If PRA ID received is "core network pre-configured presence reporting area", then, P-GW ignores the "Element List" coming from PCRF. Otherwise, if PRA ID is "UE-dedicated Presence Reporting Area", then, P-GW parses the "Element List" and forwards it toward the access side.
If PRA ID values from PCRF are 1 octet, 2 octets, and 3 octets.	<p>MSB of the value received from the PCRF is evaluated to find the PRA type. While encoding, GTPC side zeros are prepended to make it 3 octets.</p> <p>For example, if PRA ID = FC (1111 1100) is received from PCRF it is considered as UE-dedicated PRA and while decoding it is decoded as 00 00 FC.</p> <p>P-GW forwards PRA information toward the roaming subscriber if it is received from the PCRF or from UE.</p> <p>Important Change of UE presence in the Presence Reporting Area reporting does not apply to the roaming scenario.</p>
Roaming Scenario	<p>Change of UE presence in the Presence Reporting Area reporting does not apply to the roaming scenario.</p> <p>When the serving EPC node (MME, S4-SGSN) is changed, the Presence Reporting Area identifier is transferred for all PDN connections as part of the MM Context information to the target serving node during the mobility procedure. The list of Presence Reporting Area elements are also transferred if they are provided by the P-GW.</p>

Scenario	Behavior
Handover Behavior: How the PRA identifier is communicated from source MME/S4-SGSN to target MME/S4-SGSN.	<p>MME/S4-SGSN gets the PRA Identifier from source MME/S4-SGSN as part of MM Context information.</p> <p>When the serving EPC node (MME, S4-SGSN) is changed, the Presence Reporting Area identifier is transferred for all PDN connections as part of the MM Context information to the target serving node during the mobility procedure. The list of Presence Reporting Area elements are also transferred if they are provided by the P-GW.</p>
Handoff Behavior: How PRA is disabled when the new access type is not supported PRA.	<p>Depending on the access type and internal configuration PCRF deactivates the PRA, if the new access PRA is not supported.</p> <p>During an IP-CAN session, P-GW notifies the PCRF that the UE is located in an access type, where local PCRF configuration is such that the reporting changes of the UE presence in the PRA are not supported. The PCRF unsubscribes to the change of UE presence in the PRA, if previously activated.</p>
Behavior if for E-UTRAN some nodes do not support PRA.	<p>If PRA is enabled from PCRF, then EPC nodes supports it. If all nodes are not supported, then PRA PCRF activates the Location Change Reporting.</p> <p>Important For E-UTRAN access, homogeneous support of reporting changes of UE presence in a Presence Reporting Area in a network is assumed. When the PCRF configuration indicates that reporting changes of the UE presence in a PRA is supported for E-UTRAN, this means all P-GWs, all MME, and all S-GW support it, including the MME and S-GW working in the network sharing mode. If the change of UE presence in the PRA reporting is not supported, the PCRF may instead activate the location change reporting at the cell or serving area level.</p>
When access side procedure failure or collision occurs (Create or Update Bearer procedure)	<p>In Update or Create bearer procedure failure where the PRA action was sent in the request message and if PRA information was not received in response message, P-GW attempts to send the PRA action in next control procedure toward the remote peer.</p> <p>In Update or Create bearer procedure failure where PRA action was sent in the request message and if PRA information was not received in the response message, P-GW assumes it as PRA action was successfully communicated toward the remote peer.</p> <p>In the Update or Create bearer collision scenario where PRA action was sent in the request message and Update or Create procedure got aborted, P-GW attempts to send the PRA action in next control procedure toward the remote peer.</p>

Multiple Presence Reporting Area



Important This feature is introduced in release 21.9.1.

P-GW supports negotiation of Multiple-Presence Reporting Area feature in Feature-List-ID 2 over Gx interface with PCRF. The CNO-ULI feature will be used only when the P-GW and/or the PCRF does not support Multiple-PRA and both P-GW and PCRF support CNO-ULI.

When the Multiple-PRA feature is supported during the lifetime of the IP-CAN session P-GW handles the change of UE Presence in Reporting Area(s) request from PCRF in PRA-Install AVP including the Presence-Reporting-Area-Information AVP(s) which each contains the Presence Reporting Area Identifier within the Presence-Reporting-Area-Identifier AVP.

P-GW Handling the Event Trigger

CHANGE_OF_UE_PRESENCE_IN_PRESENCE_REPORTING_AREA_REPORT from PCRF for the activation of the reporting changes of UE presence in Presence Reporting Area(s).

P-GW handles the PRA Identifier(s) modify request from PCRF with the new PRA within the PRA-Install AVP as described above and/or by removing the existing PRA(s) within the PRA-Remove AVP. In this case, the Presence-Reporting-Area-Identifier AVP of the removed PRA must be included within the Presence-Reporting-Area-Information AVP(s).

P-GW supports PRA-Install and PRA-Remove AVPs from PCRF in the following messages:

- CC-Answer (CCA) Command
- Re-Auth-Request (RAR) Command

The P-GW handles the request from PCRF to unsubscribe to the change of UE presence in Presence Reporting Area wherein PCRF provides the Event-Trigger AVP with the value CHANGE_OF_UE_PRESENCE_IN_PRESENCE_REPORTING_AREA_REPORT (48) removed, if previously activated.

P-GW supports the maximum of 4 PRA(s) for a IP-CAN session at any given point of time. The maximum number of PRAs is configurable in PCRF and must be capped to 4. P-GW will ignore the Presence Reporting Area Identifiers entries beyond 4.

When the P-GW receives the presence reporting area information from the serving node over S5/S8 interface indicating that the UE is inside or outside of one or more presence reporting areas or any of the presence reporting areas is set to inactive, the P-GW will check if the reported presence reported area identifier corresponds to a presence reporting area that is relevant for the PCRF. In that case, the P-GW reports the CHANGE_OF_UE_PRESENCE_IN_PRESENCE_REPORTING_AREA_REPORT event in the Event-Trigger AVP additionally, the P-GW also reports the presence reporting area status within the Presence-Reporting-Area-Status AVP and presence reporting area identifier within Presence-Reporting-Area-Identifier AVP included in Presence-Reporting-Area-Information AVP(s) for each of the presence reporting areas reported by the serving node.

The P-GW de-activates the relevant IP-CAN specific procedure for reporting change of UE presence in Presence Reporting Area, when the PCRF and OCS unsubscribe to change of UE presence in Presence Reporting Area.

PRA-Install AVP (3GPP-EPS access type) Definition

The PRA-Install AVP (AVP code 2845) is of type Grouped, and it is used to provision a list of new or updated Presence Reporting Area(s) for an IP-CAN session.

AVP Format:

```
PRA-Install ::= < AVP Header: 2845 >
  * [ Presence-Reporting-Area-Information ]
  * [ AVP ]
```

PRA-Remove AVP (3GPP-EPS access type) Definition

The PRA-Remove AVP (AVP code 2846) is of type Grouped, and it is used to stop the reporting of a list of Presence Reporting Area(s) for an IP-CAN session.

AVP Format:

```
PRA-Remove ::= < AVP Header: 2846 >
  * [ Presence-Reporting-Area-Identifier ]
  * [ AVP ]
```

Configuring Presence Reporting Area

Configuring PRA

Use the following configuration to enable the PRA:

```
configure
  context context_name
    ims-auth-service service_name
      policy-control
        diameter encode-supported-features cno-uli
        { default | no } diameter encode-supported-features
      end
```

NOTES:

- **diameter encode-supported-features:** Enables or disables encoding and sending of Supported-Features AVP.
- **cno-uli:** Enables Presence Reporting Area Information Reporting feature.
- **no:** Removes the previously configured supported features.
- **default:** Applies the default setting for this command.

Configuring Multiple-PRA

Use the following configuration to enable Multiple Presence Reporting Area (Multiple-PRA) Feature.

```
configure
  context context_name
    ims-auth-service service_name
      policy-control
        diameter encode-supported-features multiple-pra
```



```
{ default | no } diameter encode-supported-features
end
```

NOTES:

- **ims-auth-service** *service_name*: Creates an IMS authentication service. *service_name* must be an alphanumeric string of 1 through 63 characters.
- **policy-control**: Configures Diameter authorization and policy control parameter for IMS authorization.
- **diameter encode-supported-features**: Enables encoding and sending of Supported-Features AVP.
- **multiple-pra**: Enables the Multiple Presence Reporting Area Information Reporting feature.
- **no**: Removes the previously configured supported features.
- **default**: Applies the default setting for this command.

Monitoring and Troubleshooting

The following sections describe commands available to monitor the feature.

Show Commands and Outputs

This section provides information regarding show commands and their outputs in support of this feature.

show ims-authorization service name <service-name>

The output of the above command is modified to display the negotiated conditional policy features related information. The modified output is as follows:

```
Context: ha
IMS Authorization Service name: imsa-Gx
.....
Diameter Policy Control:
Endpoint: gx.st16.starentnetworks.com
Origin-Realm: starentnetworks.com
Dictionary: r8-gx-standard
Supported Features:
  mission-critical-qcis
  conditional-policy-info-default-qos
cno-uli
Request Timeout:
  Initial Request   : 100 deciseconds
  Update Request   : 100 deciseconds
  Terminate Request : 100 deciseconds
Endpoint Peer Select: Not Enabled
Reauth Trigger: All
Custom Reauth Trigger:
  QoS-Change
```

show ims-authorization sessions full all

The output of this command includes the following fields:

show ims-authorization service statistics

```

CallId: 00004e26          Service Name: imsa-Gx
IMSI: 123456789012349
Session ID: gx.stl6.starentnetworks.com;20006;2305;598ab8cf-102
Bearer Type: GTP
SGSN IP-Addr: 192.168.23.4
APN: starent.com
Bearer Control Mode: UE/NW
State: Connected
Negotiated Supported Features:
  3gpp-r8
  conditional-policy-info-default-qos
  cno-uli
Auth Decision:
  Event Triggers:
    QoS-Change
    RAT-Change
    Change-Of-UE-Presence-In-PRA
    Usage-Report
    Resource-Modification-Request
    multiple-pra

```

show ims-authorization service statistics

The output of the above command is modified to display the PRA feature statistics. The modified output is as follows:

```

IMS Auth Service Statistics Summary:
Total Services:          2
Auth Session:
  Current Active:          1
  Current Fallback Session: 0
  Total Attempted:        1
  Total Failed:           0
  Total Fallback:         0
  Current PCRF Session:   1
  Total Setup:            1
  Total Released:         0
Re-Authorization Triggers:
  SGSN Change:            0
  RAT Change:             0
  Bearer Recovery:        0
  QoS Change:             0
  IP-CAN Change:          0
  Max Num of Bearers Rchd: 0
  RAI Change:             0
  TAI Change:             0
  PCRF Triggered ReAuth: 0
  Reactivation Changed:   0
  AN GW Changed:          0
  Reallocation Of Credit: 0
  Successful Resource Alloc: 0
  Service Flow Detection: 0
  UE IP Address Allocate: 0
  Resource Modification Req: 0
  Def Bearer QoS Mod Failure: 0
  Chrg Correlation Exchange: 0
  Session Recovery:       0
  Access Nw Info Report:  0
  Application Start:      0
  Change Of UE Presence In PRA: 1
  Local Fallback:         0
  CCRU sent:              0
  PLMN Change:           0
  TFT Change:            0
  Bearer Loss:           0
  Policy Failure:        0
  Resources Limitation:  0
  QoS Chng Exceeding Auth: 0
  User Location Change:  0
  ECGI Change:           0
  Preservation Changed:  0
  Revalidation Timeout:  0
  Out Of Credit Reauth:  0
  Def EPS Bearer QoS Chng: 0
  Usage Report:          0
  UE Timezone Change:    0
  UE IP Address Release: 0
  APN AMBR Mod Failure:  0
  Tethering Flow Detected: 0
  Subnet Change:         0
  Session Sync:          0
  DCCA Failure Report:   0
  Application Stop:      0

```

show subscribers pgw-only full all

The output of this command includes the following fields:

```

Username           : xyz
Subscriber Type    : Visitor
Status             : Online/Active
State              : Connected
Connect Time       : Mon Aug 28 07:32:13 2017
Auto Delete        : No
Idle time          : 00h00m06s
MS TimeZone        : n/a
Access Type: gtp-pdn-type-ipv4
Access Tech: eUTRAN
Callid: 00004e23
MSISDN: 9326737733
Interface Type: S5S8GTP
TWAN Mode: N/A
eMPS Bearer: No
Emergency Bearer Type: N/A
IMS-media Bearer: No
S6b Auth Status: Enabled
Access Peer Profile: default
Acct-session-id (C1): COA8170100000003
ThreeGPP2-correlation-id (C2): 00500660 / 002shwI-
Card/Cpu: 2/0
ULI:
  TAI-ID:
    MCC: 214 MNC: 365
    TAC: 0x6789
  ECGI-ID:
    MCC: 214 MNC: 365
    ECI: 0x1234567
PRA Information:
  PRA-ID: 0x801204      Action: Start      Status: In
PRA Information:
  PRA-ID: 0xA11202     Action: Start      Status: N/A
Daylight Saving Time: n/a
Network Type: IP
pgw-service-name: pgwl
IMSI: 123456789012349
Low Access Priority: N/A
Sessmgr Instance: 1

```

show subs saegw-only full all

The output of the above command is modified to include the PRA Information such as PRA-ID, PRA Status, and PRA Action. The modified output is as follows:

```

Username           : xyz
SAEGW Call mode    : Co-located
Subscriber Type     : Visitor
Status             : Online/Active
State              : Connected
Bearer State       : Active
Connect Time       : Mon Aug 28 08:21:45 2017

SAEGW UID          : 10001
Idle time          : 00h00m19s
Auto Delete        : No
Callid             : 4e25
Card/Cpu           : 2/0
Source context     : ingress
Bearer Type        : Default
Access Type        : gtp-pdn-type-ipv4
Access Tech        : eUTRAN
MSISDN            : 9326737733
IMSI               : 241460144418770
Sessmgr Instance   : 1
Destination context : egress
Bearer-Id          : 5
Network Type       : IP
saegw-service-name : saegw

```

show subs saegw-only full all

```

TWAN Mode           : N/A
eMPS Bearer         : No
IPv6 alloc type     : n/a
ECS Rulebase        : prepaid
Chrg Char Sel Mod   : Peer Supplied
Restoration priority level : n/a
HLCOM Session       : No
IP Address          : 10.0.0.5
Bearer capable for restoration: No
UE P-CSCF Restoration Support : No

Peer Profile        :
  PGW Access        : default
  SGW Access        : default
  SGW Network       : default

ULI                 : TAI-ID
  MCC               : 214
  LAC               : n/a
  SAC               : n/a
  CI                : n/a
  MNC               : 214
  TAC               : 0x6789
  RAC               : n/a
  ECI               : 0x1234567

PRA Information     :
  PRA-ID: 0xFC0104   Action: Start   Status: In

Bearer QoS          :
  QCI               : 5
  ARP               : 0x08
  PCI               : 0 (Enabled)
  PL                : 2
  PVI               : 0 (Enabled)
  MBR Uplink(bps)  : 0
  GBR Uplink(bps)  : 0
  MBR Downlink(bps) : 0
  GBR Downlink(bps) : 0

```



CHAPTER 47

Proxy-Mobile IP

This chapter describes system support for Proxy Mobile IP and explains how it is configured. The product administration guides provide examples and procedures for configuration of basic services on the system. It is recommended that you select the configuration example that best meets your service model before using the procedures in this chapter.

Proxy Mobile IP provides a mobility solution for subscribers with mobile nodes (MNs) capable of supporting only Simple IP.

This chapter includes the following sections:

- [Overview, on page 861](#)
- [How Proxy Mobile IP Works in 3GPP2 Network, on page 864](#)
- [How Proxy Mobile IP Works in 3GPP Network, on page 868](#)
- [How Proxy Mobile IP Works in WiMAX Network, on page 871](#)
- [How Proxy Mobile IP Works in a WiFi Network with Multiple Authentication, on page 875](#)
- [Configuring Proxy Mobile-IP Support, on page 881](#)

Overview

Proxy Mobile IP provides mobility for subscribers with MNs that do not support the Mobile IP protocol stack.



Important Proxy Mobile IP is a licensed Cisco feature. A separate feature license may be required. Contact your Cisco account representative for detailed information on specific licensing requirements. For information on installing and verifying licenses, refer to the *Managing License Keys* section of the *Software Management Operations* chapter in the *System Administration Guide*.

The Proxy Mobile IP feature is supported for various products. The following table indicates the products on which the feature is supported and the relevant sections within the chapter that pertain to that product.

Table 70: Applicable Products and Relevant Sections

Applicable Product(s)	Refer to Sections
PDSN	<ul style="list-style-type: none"> • Proxy Mobile IP in 3GPP2 Service, on page 863 • How Proxy Mobile IP Works in 3GPP2 Network, on page 864 • Configuring FA Services, on page 881 • Configuring Proxy MIP HA Failover, on page 882 • Configuring HA Services • Configuring Subscriber Profile RADIUS Attributes, on page 883 • RADIUS Attributes Required for Proxy Mobile IP, on page 883 • Configuring Local Subscriber Profiles for Proxy-MIP on a PDSN, on page 884 • Configuring Default Subscriber Parameters in Home Agent Context, on page 884
GGSN	<ul style="list-style-type: none"> • Proxy Mobile IP in 3GPP Service, on page 863 • How Proxy Mobile IP Works in 3GPP Network, on page 868 • Configuring FA Services, on page 881 • Configuring Proxy MIP HA Failover, on page 882 • Configuring HA Services • Configuring Subscriber Profile RADIUS Attributes, on page 883 • RADIUS Attributes Required for Proxy Mobile IP, on page 883 • Configuring Default Subscriber Parameters in Home Agent Context, on page 884 • Configuring APN Parameters, on page 885
ASN GW	<ul style="list-style-type: none"> • Proxy Mobile IP in WiMAX Service, on page 864 • How Proxy Mobile IP Works in WiMAX Network, on page 871 • Configuring FA Services, on page 881 • Configuring Proxy MIP HA Failover, on page 882 • Configuring HA Services • Configuring Subscriber Profile RADIUS Attributes, on page 883 • RADIUS Attributes Required for Proxy Mobile IP, on page 883 • Configuring Default Subscriber Parameters in Home Agent Context, on page 884

Applicable Product(s)	Refer to Sections
PDIF	<ul style="list-style-type: none"> • How Proxy Mobile IP Works in a WiFi Network with Multiple Authentication, page 875 • Configuring FA Services, on page 881 • Configuring Proxy MIP HA Failover, on page 882 • Configuring HA Services • Configuring Subscriber Profile RADIUS Attributes, on page 883 • RADIUS Attributes Required for Proxy Mobile IP, on page 883 • Configuring Default Subscriber Parameters in Home Agent Context, on page 883

Proxy Mobile IP in 3GPP2 Service

For subscriber sessions using Proxy Mobile IP, R-P and PPP sessions get established between the MN and the PDSN as they would for a Simple IP session. However, the PDSN/FA performs Mobile IP operations with an HA (identified by information stored in the subscriber's profile) on behalf of the MN (i.e. the MN is only responsible for maintaining the Simple IP PPP session with PDSN).

The MN is assigned an IP address by either the PDSN/FA or the HA. Regardless of its source, the address is stored in a mobile binding record (MBR) stored on the HA. Therefore, as the MN roams through the service provider's network, each time a hand-off occurs, the MN will continue to use the same IP address stored in the MBR on the HA.

Note that unlike Mobile IP-capable MNs that can perform multiple sessions over a single PPP link, Proxy Mobile IP allows only a single session over the PPP link. In addition, simultaneous Mobile and Simple IP sessions will not be supported for an MN by the FA that is currently facilitating a Proxy Mobile IP session for the MN.

The MN is assigned an IP address by either the HA, a AAA server, or on a static-basis. The address is stored in a mobile binding record (MBR) stored on the HA. Therefore, as the MN roams through the service provider's network, each time a hand-off occurs, the MN will continue to use the same IP address stored in the MBR on the HA.

Proxy Mobile IP in 3GPP Service

For IP PDP contexts using Proxy Mobile IP, the MN establishes a session with the GGSN as it normally would. However, the GGSN/FA performs Mobile IP operations with an HA (identified by information stored in the subscriber's profile) on behalf of the MN (i.e. the MN is only responsible for maintaining the IP PDP context with the GGSN, no Agent Advertisement messages are communicated with the MN).

The MN is assigned an IP address by either the HA, a AAA server, or on a static-basis. The address is stored in a mobile binding record (MBR) stored on the HA. Therefore, as the MN roams through the service provider's network, each time a hand-off occurs, the MN will continue to use the same IP address stored in the MBR on the HA.

Proxy Mobile IP can be performed on a per-subscriber basis based on information contained in their user profile, or for all subscribers facilitated by a specific APN. In the case of non-transparent IP PDP contexts, attributes returned from the subscriber's profile take precedence over the configuration of the APN.

Proxy Mobile IP in WiMAX Service

For subscriber sessions using Proxy Mobile subscriber sessions get established between the MN and the ASN GW as they would for a Simple IP session. However, the ASN GW/FA performs Mobile IP operations with an HA (identified by information stored in the subscriber's profile) on behalf of the MN (i.e. the MN is only responsible for maintaining the Simple IP subscriber session with ASN GW).

The MN is assigned an IP address by either the ASN GW/FA or the HA. Regardless of its source, the address is stored in a mobile binding record (MBR) stored on the HA. Therefore, as the MN roams through the service provider's network, each time a hand-off occurs, the MN will continue to use the same IP address stored in the MBR on the HA.

Note that unlike Mobile IP-capable MNs that can perform multiple sessions over a single session link, Proxy Mobile IP allows only a single session over the session link. In addition, simultaneous Mobile and Simple IP sessions will not be supported for an MN by the FA that is currently facilitating a Proxy Mobile IP session for the MN.

How Proxy Mobile IP Works in 3GPP2 Network

This section contains call flows displaying successful Proxy Mobile IP session setup scenarios. There are multiple scenarios that are dependant on how the MN receives an IP address. The following scenarios are described:

- **Scenario 1:** The AAA server that authenticates the MN at the PDSN allocates an IP address to the MN. Note that the PDSN does not allocate an address from its IP pools.
- **Scenario 2:** The HA assigns an IP address to the MN from one of its locally configured dynamic pools.

Scenario 1: AAA server and PDSN/FA Allocate IP Address

The following figure and table display and describe a call flow in which the MN receives its IP address from the AAA server and PDSN/FA.

Figure 127: AAA/PDSN Assigned IP Address Proxy Mobile IP Call Flow

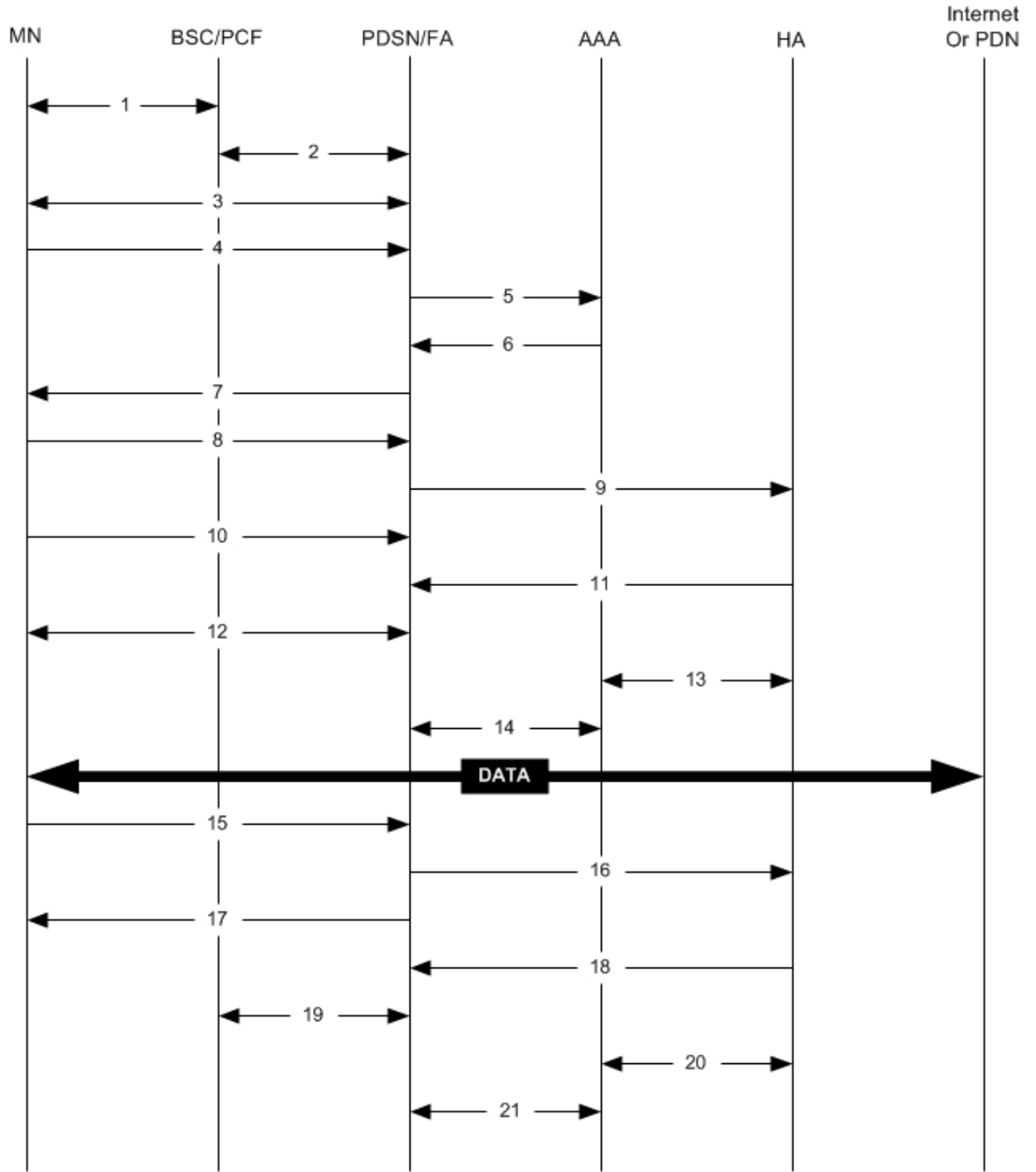

335164

Table 71: AAA/PDSN Assigned IP Address Proxy Mobile IP Call Flow Description

Step	Description
1	Mobile Node (MN) secures a traffic channel over the airlink with the RAN through the BSC/PCF.
2	The PCF and PDSN/FA establish the R-P interface for the session.

Step	Description
3	The PDSN/FA and MN negotiate Link Control Protocol (LCP).
4	Upon successful LCP negotiation, the MN sends a PPP Authentication Request message to the PDSN/FA.
5	The PDSN/FA sends an Access Request message to the RADIUS AAA server.
6	The RADIUS AAA server successfully authenticates the subscriber and returns an Access Accept message to PDSN/FA. The Accept message may contain various attributes to be assigned to the MN including the MN's Home Address (IP address) and the IP address of the HA to use.
7	The PDSN/FA sends a PPP Authentication Response message to the MN.
8	The MN sends an Internet Protocol Control Protocol (IPCP) Configuration Request message to the PDSN/FA with an MN address of 0.0.0.0.
9	The PDSN/FA forwards a Proxy Mobile IP Registration Request message to the HA. The message includes fields such as the MN's home address, the IP address of the FA (the care-of-address), and the FA-HA extension (security parameter index (SPI)).
10	While the FA is communicating with the HA, the MN may send additional IPCP Configuration Request messages.
11	The HA responds with a Proxy Mobile IP Registration Response after validating the home address against its policy. The HA also creates a mobile binding record (MBR) for the subscriber session.
12	The MN and the PDSN/FA negotiate IPCP. The result is that the MN is assigned the home address originally specified by the AAA server.
13	While the MN and PDSN/FA are negotiating IPCP, the HA and AAA server initiate accounting.
14	Upon completion of the IPCP negotiation, the PDSN/FA and AAA server initiate accounting fully establishing the session allowing the MN to send/receive data to/from the PDN.
15	Upon completion of the session, the MN sends an LCP Terminate Request message to the PDSN to end the PPP session.
16	The PDSN/FA sends a Proxy Mobile IP De-registration Request message to the HA.
17	The PDSN/FA send an LCP Terminate Acknowledge message to the MN ending the PPP session.
18	The HA sends a Proxy Mobile IP De-Registration Response message to the FA terminating the Pi interface.
19	The PDSN/FA and the PCF terminate the R-P session.
20	The HA and the AAA server stop accounting for the session.
21	The PDSN and the AAA server stop accounting for the session.

Scenario 2: HA Allocates IP Address

The following figure and table display and describe a call flow in which the MN receives its IP address from the HA.

Figure 128: HA Assigned IP Address Proxy Mobile IP Call Flow

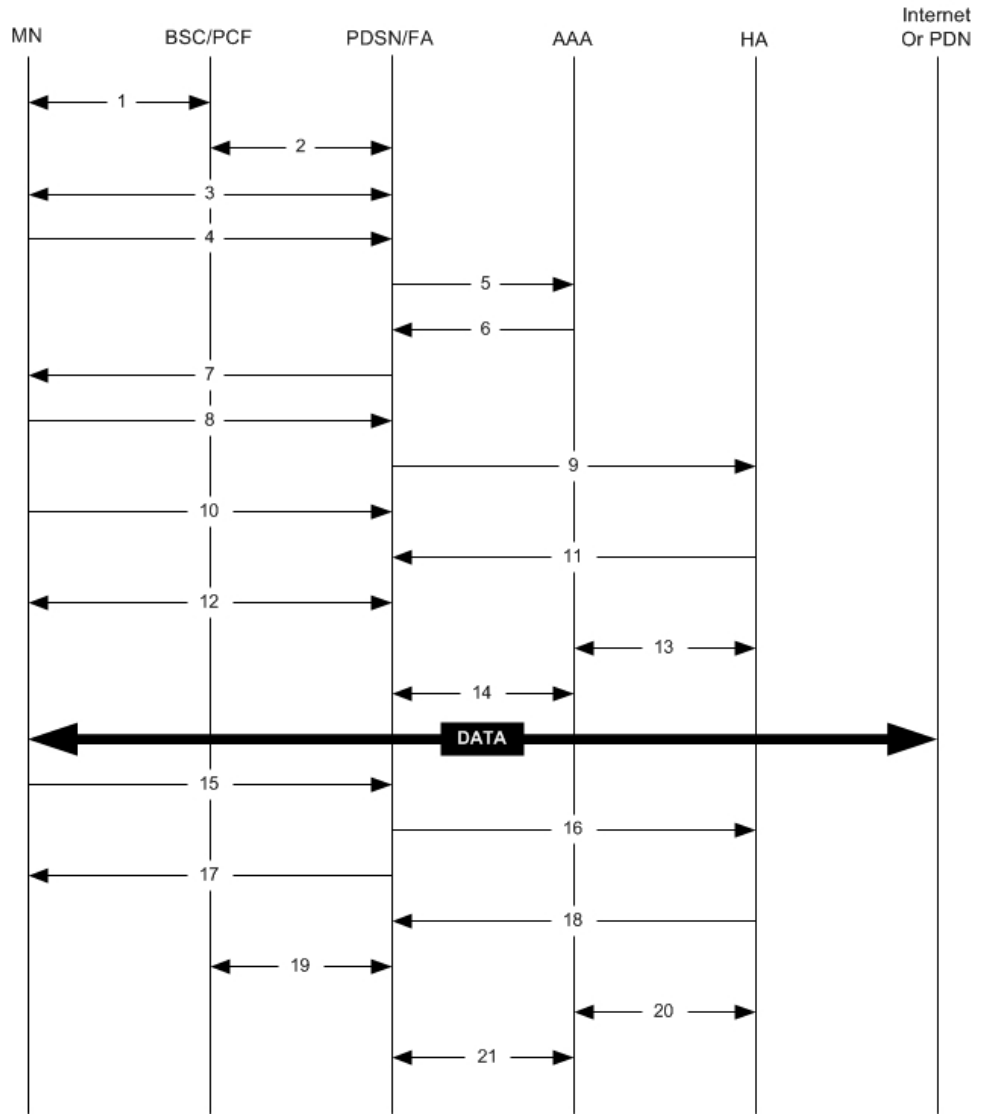

335164

Table 72: HA Assigned IP Address Proxy Mobile IP Call Flow Description

Step	Description
1	Mobile Node (MN) secures a traffic channel over the airlink with the RAN through the BSC/PCF.
2	The PCF and PDSN/FA establish the R-P interface for the session.
3	The PDSN/FA and MN negotiate Link Control Protocol (LCP).
4	Upon successful LCP negotiation, the MN sends a PPP Authentication Request message to the PDSN/FA.
5	The PDSN/FA sends an Access Request message to the RADIUS AAA server.

Step	Description
6	The RADIUS AAA server successfully authenticates the subscriber and returns an Access Accept message to the PDSN/FA. The Accept message may contain various attributes to be assigned to the MN including the IP address of the HA to use.
7	The PDSN/FA sends a PPP Authentication Response message to the MN.
8	The MN sends an Internet Protocol Control Protocol (IPCP) Configuration Request message to the PDSN/FA with an MN address of 0.0.0.0.
9	The PDSN/FA forwards a Proxy Mobile IP Registration Request message to the HA. The message includes fields such as a Home Address indicator of 0.0.0.0, the IP address of the FA (the care-of-address), the IP address of the MN (the care-of-address), and the FA-HA extension (security parameter index (SPI)).
10	While the FA is communicating with the HA, the MN may send additional IPCP Configuration Request messages.
11	The HA responds with a Proxy Mobile IP Registration Response. The response includes an IP address from one of its locally configured pools to assign to the MN (its Home Address). The HA also creates a mobile binding record (MBR) for the subscriber session.
12	The MN and the PDSN/FA negotiate IPCP. The result is that the MN is assigned the home address originally specified by the AAA server.
13	While the MN and PDSN/FA are negotiating IPCP, the HA and AAA server initiate accounting.
14	Upon completion of the IPCP negotiation, the PDSN/FA and AAA server initiate accounting fully establishing the session allowing the MN to send/receive data to/from the PDN.
15	Upon completion of the session, the MN sends an LCP Terminate Request message to the PDSN to end the PPP session.
16	The PDSN/FA sends a Proxy Mobile IP De-registration Request message to the HA.
17	The PDSN/FA send an LCP Terminate Acknowledge message to the MN ending the PPP session.
18	The HA sends a Proxy Mobile IP De-Registration Response message to the FA terminating the Pi interface.
19	The PDSN/FA and the PCF terminate the R-P session.
20	The HA and the AAA server stop accounting for the session.
21	The PDSN and the AAA server stop accounting for the session.

How Proxy Mobile IP Works in 3GPP Network

This section contains call flows displaying successful Proxy Mobile IP session setup scenarios in 3GPP network.

The following figure and the text that follows describe a sample successful Proxy Mobile IP session setup call flow in 3GPP service.

Figure 129: Proxy Mobile IP Call Flow in 3GPP

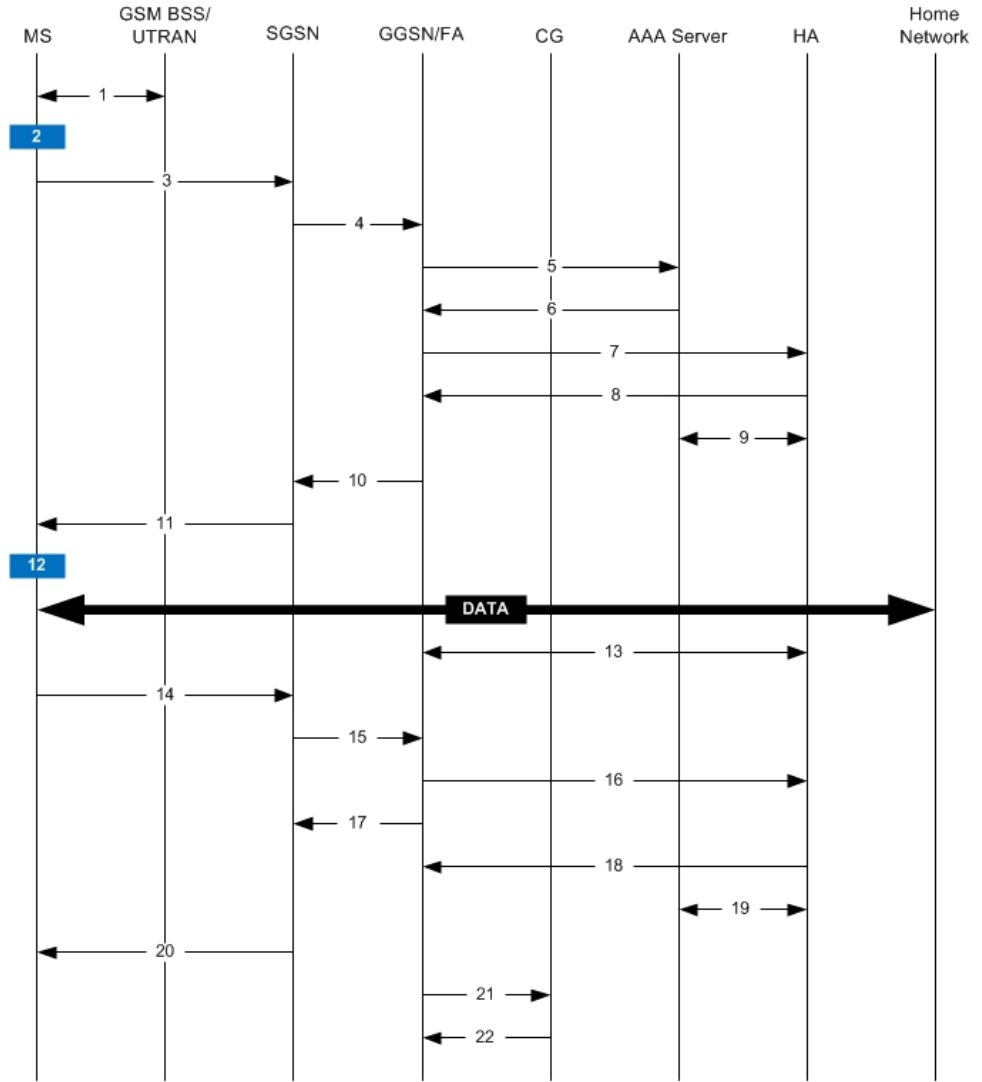

335165

Table 73: Proxy Mobile IP Call Flow in 3GPP Description

Step	Description
1	The mobile station (MS) goes through the process of attaching itself to the GPRS/UMTS network.

Step	Description
2	<p>The terminal equipment (TE) aspect of the MS sends AT commands to the mobile terminal (MT) aspect of the MS to place it into PPP mode.</p> <p>The Link Control Protocol (LCP) is then used to configure the Maximum-Receive Unit size and the authentication protocol (Challenge-Handshake Authentication Protocol (CHAP), Password Authentication Protocol (PAP), or none). If CHAP or PAP is used, the TE will authenticate itself to the MT, which, in turn, stores the authentication information.</p> <p>Upon successful authentication, the TE sends an Internet Protocol Control Protocol (IPCP) Configure-Request message to the MT. The message will either contain a static IP address to use or request that one be dynamically assigned.</p>
3	<p>The MS sends an Activate PDP Context Request message that is received by an SGSN. The message contains information about the subscriber such as the Network layer Service Access Point Identifier (NSAPI), PDP Type, PDP Address, Access Point Name (APN), quality of service (QoS) requested, and PDP configuration options.</p>
4	<p>The SGSN authenticates the request message and sends a Create PDP Context Request message to a GGSN using the GPRS Tunneling Protocol (GTPC, "C" indicates the control signalling aspect of the protocol). The recipient GGSN is selected based on either the request of the MS or is automatically selected by the SGSN. The message consists of various information elements including: PDP Type, PDP Address, APN, charging characteristics, and tunnel endpoint identifier (TEID, if the PDP Address was static).</p>
5	<p>The GGSN determines if it can facilitate the session (in terms of memory or CPU resources, configuration, etc.) and creates a new entry in its PDP context list and provides a Charging ID for the session.</p> <p>From the APN specified in the message, the GGSN determines whether or not the subscriber is to be authenticated if Proxy Mobile IP is to be supported for the subscriber, and if so, the IP address of the HA to contact.</p> <p>Note that Proxy Mobile IP support can also be determined by attributes in the user's profile. Attributes in the user profile supersede APN settings.</p> <p>If authentication is required, the GGSN attempts to authenticate the subscriber locally against profiles stored in memory or send a RADIUS Access-Request message to a AAA server.</p>
6	<p>If the GGSN authenticated the subscriber to a AAA server, the AAA server responds with a RADIUS Access-Accept message indicating successful authentication and any attributes for handling the subscriber PDP context.</p>
7	<p>If Proxy Mobile IP support was either enabled in the APN or in the subscriber's profile, the GGSN/FA forwards a Proxy Mobile IP Registration Request message to the specified HA. The message includes such things as the subscriber's home address, the IP address of the FA (the care-of-address), and the FA-HA extension (security parameter index (SPI)).</p>
8	<p>The HA responds with a Proxy Mobile IP Registration Response. The response includes an IP address from one of its locally configured pools to assign to the MS (its Home Address). The HA also creates a mobile binding record (MBR) for the subscriber session.</p>
9	<p>The HA sends an RADIUS Accounting Start request to the AAA server which the AAA server responds to.</p>
10	<p>The GGSN replies with an affirmative Create PDP Context Response using GTPC. The response will contain information elements such as the PDP Address representing either the static address requested by the MS or the address assigned by the GGSN, the TEID used to reference PDP Address, and PDP configuration options specified by the GGSN.</p>

Step	Description
11	The SGSN returns an Activate PDP Context Accept message to the MS. The message includes response to configuration parameters sent in the initial request.
12	The MT, will respond to the TE's IPCP Config-request with an IPCP Config-Ack message. The MS can now send and receive data to or from the PDN until the session is closed or times out. Note that Mobile IP, only one PDP context is supported for the MS.
13	The FA periodically sends Proxy Mobile IP Registration Request Renewal messages to the HA. The HA sends responses for each request.
14	The MS can terminate the data session at any time. To terminate the session, the MS sends a Deactivate PDP Context Request message that is received by the SGSN.
15	The SGSN sends a Delete PDP Context Request message to the GGSN facilitating the data session. The message includes the information elements necessary to identify the PDP context (i.e., TEID, and NSAPI).
16	The GGSN removes the PDP context from memory and the FA sends a Proxy Mobile IP Deregistration Request message to the HA.
17	The GGSN returns a Delete PDP Context Response message to the SGSN.
18	The HA replies to the FA with a Proxy Mobile IP Deregistration Request Response.
19	The HA sends an RADIUS Accounting Stop request to the AAA server which the AAA server responds to.
20	The SGSN returns a Deactivate PDP Context Accept message to the MS.
21	The GGSN delivers the GGSN Charging Detail Records (G-CDRs) to a charging gateway (CG) using GTP (GTPP). Note that, though not shown in this example, the GGSN could optionally be configured to send periodic CDRs while the PDP context is active.
22	For each accounting message received from the GGSN, the CG responds with an acknowledgement.

How Proxy Mobile IP Works in WiMAX Network

This section contains call flows displaying successful Proxy Mobile IP session setup scenarios. There are multiple scenarios that are dependant on how the MN receives an IP address. The following scenarios are described:

- **Scenario 1:** The AAA server that authenticates the MN at the ASN GW allocates an IP address to the MN. Note that the ASN GW does not allocate an address from its IP pools.
- **Scenario 2:** The HA assigns an IP address to the MN from one of its locally configured dynamic pools.

Scenario 1: AAA server and ASN GW/FA Allocate IP Address

The following figure and table display and describe a call flow in which the MN receives its IP address from the AAA server and ASN GW/FA.

Figure 130: AAA/ASN GW Assigned IP Address Proxy Mobile IP Call Flow

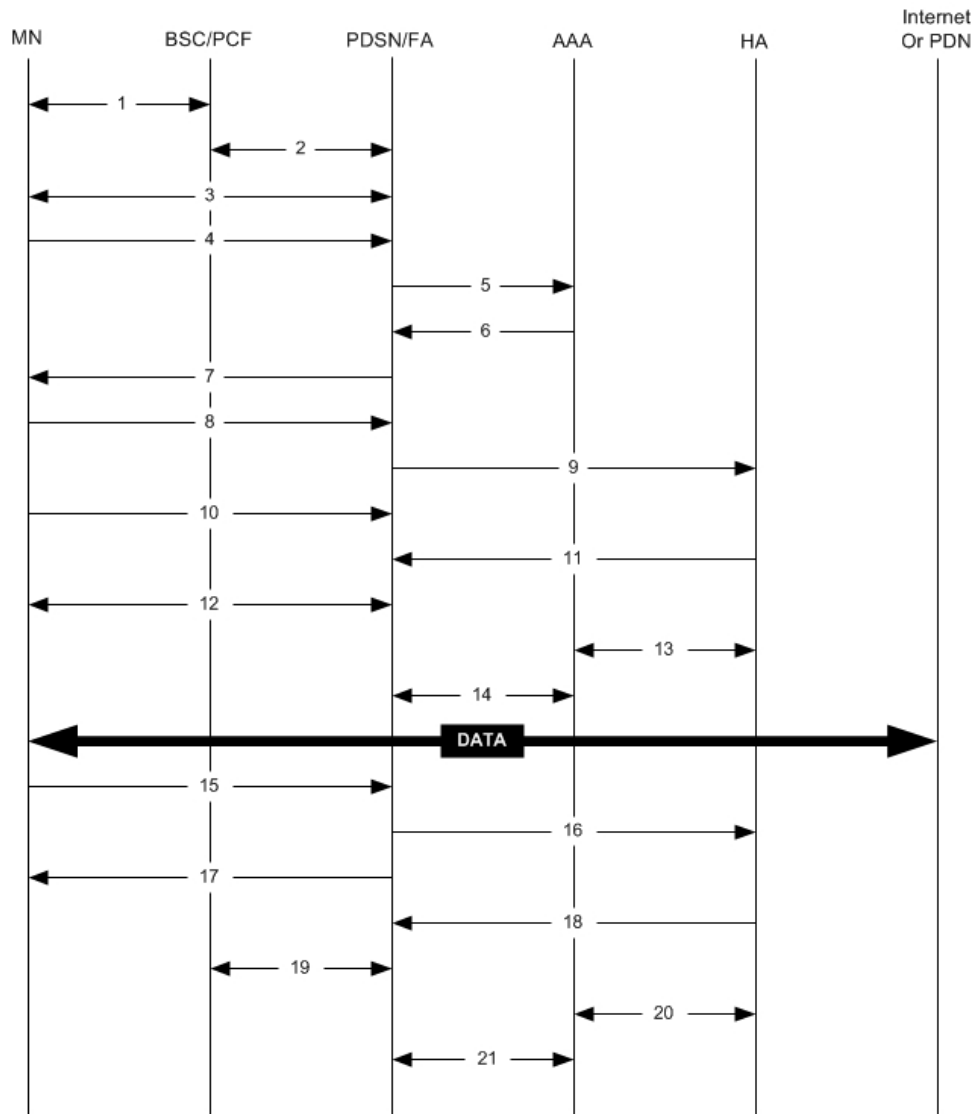

335164

Table 74: AAA/ASN GW Assigned IP Address Proxy Mobile IP Call Flow Description

Step	Description
1	Mobile Node (MN) secures a traffic channel over the airlink with the BS.
2	The BS and ASN GW/FA establish the R6 interface for the session.
3	The ASN GW/FA and MN negotiate Link Control Protocol (LCP).
4	Upon successful LCP negotiation, the MN sends a PPP Authentication Request message to the ASN GW/FA.
5	The ASN GW/FA sends an Access Request message to the RADIUS AAA server.

Step	Description
6	The RADIUS AAA server successfully authenticates the subscriber and returns an Access Accept message to the ASN GW/FA. The Accept message may contain various attributes to be assigned to the MN including the Home Address (IP address) and the IP address of the HA to use.
7	The ASN GW/FA sends a EAP Authentication Response message to the MN.
8	The MN sends an Internet Protocol Control Protocol (IPCP) Configuration Request message to the ASN GW/FA with an MN address of 0.0.0.0.
9	The ASN GW/FA forwards a Proxy Mobile IP Registration Request message to the HA. The message includes information such as the MN's home address, the IP address of the FA (the care-of-address), and the FA-HA extension (FA-HA extension parameter index (SPI)).
10	While the FA is communicating with the HA, the MN may send additional IPCP Configuration Request messages to the ASN GW/FA.
11	The HA responds with a Proxy Mobile IP Registration Response after validating the home address against the RADIUS AAA server. The HA also creates a mobile binding record (MBR) for the subscriber session.
12	The MN and the ASN GW/FA negotiate IPCP. The result is that the MN is assigned the home address originally specified by the AAA server.
13	While the MN and ASN GW/FA are negotiating IPCP, the HA and AAA server initiate accounting.
14	Upon completion of the IPCP negotiation, the ASN GW/FA and AAA server initiate accounting fully established the session allowing the MN to send/receive data to/from the PDN.
15	Upon completion of the session, the MN sends an LCP Terminate Request message to the ASN GW/FA to end the subscriber session.
16	The PDSN/FA sends a Proxy Mobile IP De-registration Request message to the HA.
17	The ASN GW/FA send an LCP Terminate Acknowledge message to the MN ending the subscriber session.
18	The HA sends a Proxy Mobile IP De-Registration Response message to the FA terminating the R3 interface.
19	The ASN GW/FA and the BS terminate the R6 session.
20	The HA and the AAA server stop accounting for the session.
21	The ASN GW and the AAA server stop accounting for the session.

Scenario 2: HA Allocates IP Address

The following figure and table display and describe a call flow in which the MN receives its IP address from the HA.

Figure 131: HA Assigned IP Address Proxy Mobile IP Call Flow

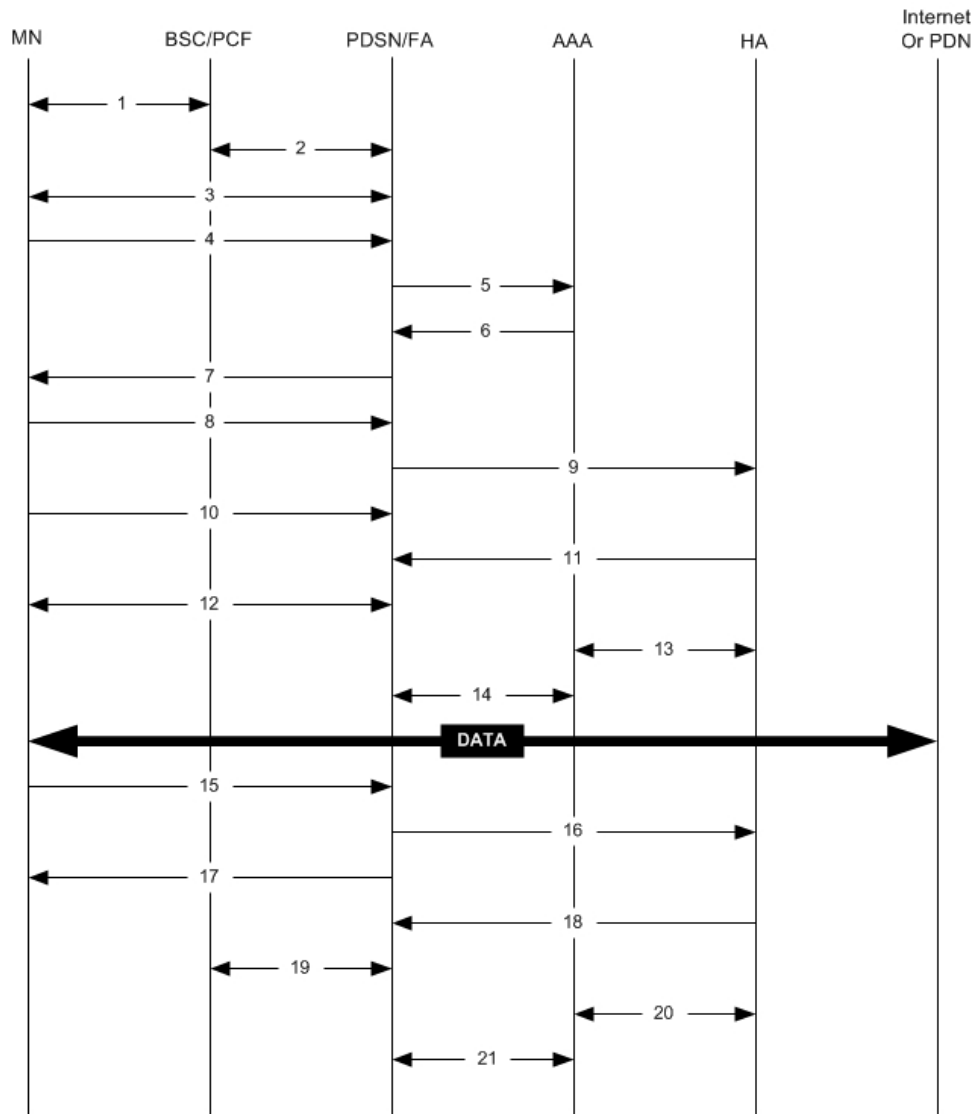

335164

Table 75: HA Assigned IP Address Proxy Mobile IP Call Flow Description

Step	Description
1	Mobile Node (MN) secures a traffic channel over the airlink with the BS.
2	The BS and ASN GW/FA establish the R6 interface for the session.
3	The ASN GW/FA and MN negotiate Link Control Protocol (LCP).
4	Upon successful LCP negotiation, the MN sends an EAP Authentication Request message to the ASN GW/FA.
5	The ASN GW/FA sends an Access Request message to the RADIUS AAA server.

Step	Description
6	The RADIUS AAA server successfully authenticates the subscriber and returns an Access Accept message to the ASN GW/FA. The Accept message may contain various attributes to be assigned to the MN including the IP address of the HA to use.
7	The ASN GW/FA sends an EAP Authentication Response message to the MN.
8	The MN sends an Internet Protocol Control Protocol (IPCP) Configuration Request message to the ASN GW/FA with an MN address of 0.0.0.0.
9	The ASN GW/FA forwards a Proxy Mobile IP Registration Request message to the HA. The message includes information such as a Home Address indicator of 0.0.0.0, the IP address of the FA (the care-of-address), the IP address of the MN, and the FA-HA extension (security parameter index (SPI)).
10	While the FA is communicating with the HA, the MN may send additional IPCP Configuration Request messages to the ASN GW/FA.
11	The HA responds with a Proxy Mobile IP Registration Response. The response includes an IP address from its locally configured pools to assign to the MN (its Home Address). The HA also creates a mobile binding record (MBR) for the subscriber session.
12	The MN and the ASN GW/FA negotiate IPCP. The result is that the MN is assigned the home address originally specified by the AAA server.
13	While the MN and ASN GW/FA are negotiating IPCP, the HA and AAA server initiate accounting.
14	Upon completion of the IPCP negotiation, the ASN GW/FA and AAA server initiate accounting fully established the session allowing the MN to send/receive data to/from the PDN.
15	Upon completion of the session, the MN sends an LCP Terminate Request message to the ASN GW/FA to end the subscriber session.
16	The ASN GW/FA sends a Proxy Mobile IP De-registration Request message to the HA.
17	The ASN GW/FA sends an LCP Terminate Acknowledge message to the MN ending the PPP session.
18	The HA sends a Proxy Mobile IP De-Registration Response message to the FA terminating the R3 interface.
19	The ASN GW/FA and the BS terminate the R6 session.
20	The HA and the AAA server stop accounting for the session.
21	The ASN GW and the AAA server stop accounting for the session.

How Proxy Mobile IP Works in a WiFi Network with Multiple Authentication

Proxy-Mobile IP was developed as a result of networks of Mobile Subscribers (MS) that are not capable of Mobile IP operation. In this scenario a PDIF acts as a mobile IP client and thus implements Proxy-MIP support.

Although not required or necessary in a Proxy-MIP network, this implementation uses a technique called Multiple Authentication. In Multi-Auth arrangements, the device is authenticated first using HSS servers.

Once the device is authenticated, then the subscriber is authenticated over a RADIUS interface to AAA servers. This supports existing EV-DO servers in the network.

The MS first tries to establish an IKEv2 session with the PDIF. The MS uses the EAP-AKA authentication method for the initial device authentication using Diameter over SCTP over IPv6 to communicate with HSS servers. After the initial Diameter EAP authentication, the MS continues with EAP MD5/GTC authentication.

After successful device authentication, PDIF then uses RADIUS to communicate with AAA servers for the subscriber authentication. It is assumed that RADIUS AAA servers do not use EAP methods and hence RADIUS messages do not contain any EAP attributes.

Assuming a successful RADIUS authentication, PDIF then sets up the IPSec Child SA tunnel using a Tunnel Inner Address (TIA) for passing control traffic only. PDIF receives the MS address from the Home Agent, and passes it on to the MS through the final AUTH response in the IKEv2 exchange.

When IPSec negotiation finishes, the PDIF assigns a home address to the MS and establishes a CHILD SA to pass data. The initial TIA tunnel is torn down and the IP address returned to the address pool. The PDIF then generates a RADIUS accounting START message.

When the session is disconnected, the PDIF generates a RADIUS accounting STOP message.

The following figures describe a Proxy-MIP session setup using CHAP authentication (EAP-MD5), but also addresses a PAP authentication setup using EAP-GTC when EAP-MD5 is not supported by either PDIF or MS.

Figure 132: Proxy-MIP Call Setup using CHAP Authentication

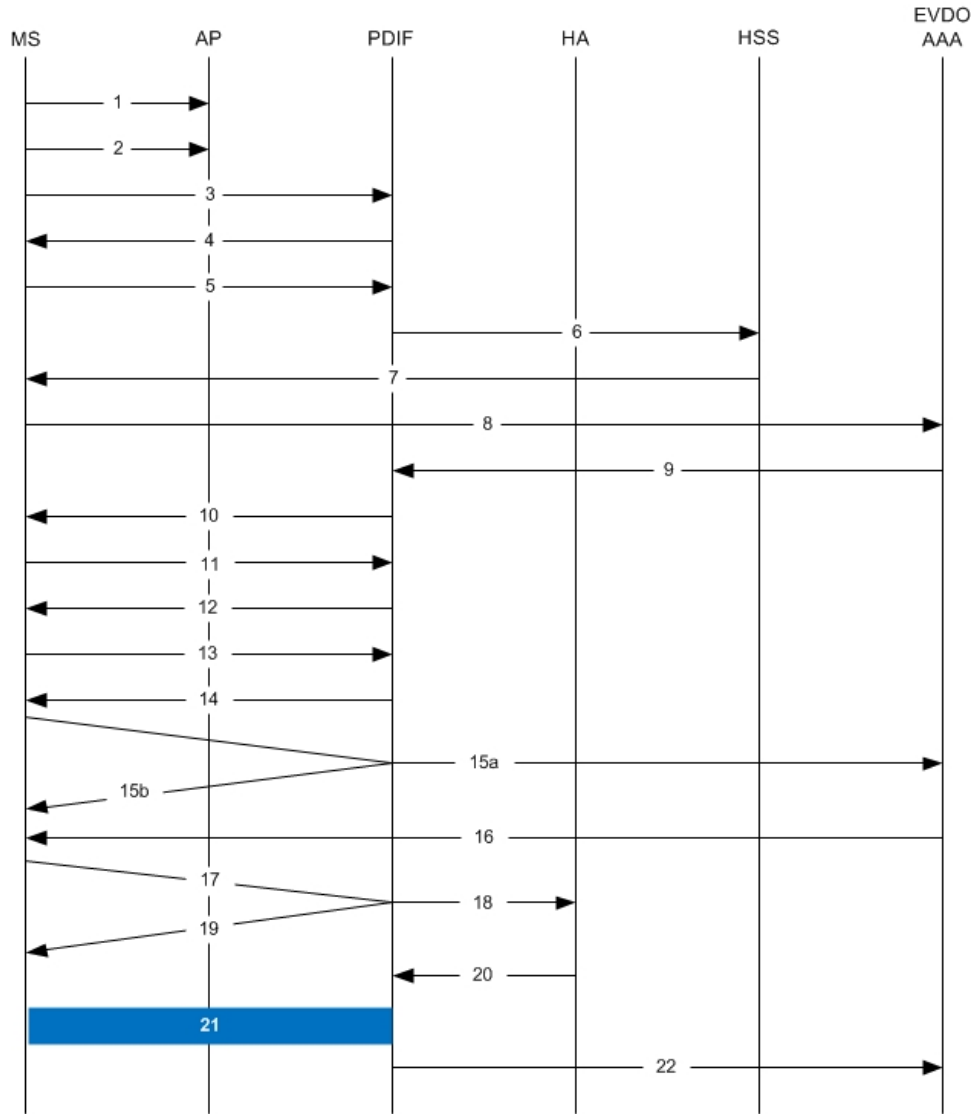

335166

Table 76: Proxy-MIP Call Setup using CHAP Authentication

Step	Description
1	On connecting to WiFi network, MS first send DNS query to get PDIF IP address
2	MS receives PDIF address from DNS
3	MS sets up IKEv2/IPSec tunnel by sending IKE_SA_INIT Request to PDIF. MS includes SA, KE, Ni, NAT-DETECTION Notify payloads in the IKEv2 exchange.

Step	Description
4	PDIF processes the IKE_SA_INIT Request for the appropriate PDIF service (bound by the destination IP address in the IKEv2 INIT request). PDIF responds with IKE_SA_INIT Response with SA, KE, Nr payloads and NAT-Detection Notify payloads. If multiple-authentication support is configured to be enabled in the PDIF service, PDIF will include MULTIPLE_AUTH_SUPPORTED Notify payload in the IKE_SA_INIT Response. PDIF will start the IKEv2 setup timer after sending the IKE_SA_INIT Response.
5	On receiving successful IKE_SA_INIT Response from PDIF, MS sends IKE_AUTH Request for the first EAP-AKA authentication. If the MS is capable of doing multiple-authentication, it will include MULTI_AUTH_SUPPORTED Notify payload in the IKE_AUTH Request. MS also includes IDi payload which contains the NAI, SA, TSi, TSr, CP (requesting IP address and DNS address) payloads. MS will not include AUTH payload to indicate that it will use EAP methods.
6	On receiving IKE_AUTH Request from MS, PDIF sends DER message to Diameter AAA server. AAA servers are selected based on domain profile, default subscriber template or default domain configurations. PDIF includes Multiple-Auth-Support AVP, EAP-Payload AVP with EAP-Response/Identity in the DER. Exact details are explained in the Diameter message sections. PDIF starts the session setup timer on receiving IKE_AUTH Request from MS.
7	PDIF receives DEA with Result-Code AVP specifying to continue EAP authentication. PDIF takes EAP-Payload AVP contents and sends IKE_AUTH Response back to MS in the EAP payload. PDIF allows IDr and CE configurations in the PDIF service and optionally includes IDr and CERT payloads (depending upon the configuration). PDIF optionally includes AUTH payload in IKE_AUTH Response if PDIF service is configured to do so.
8	MS receives the IKE_AUTH Response from PDIF. MS processes the exchange and sends a new IKE_AUTH Request with EAP payload. PDIF receives the new IKE_AUTH Request from MS and sends DER to AAA server. This DER message contains the EAP-Payload AVP with EAP-AKA challenge response and challenge received from MS.
9	The AAA server sends the DEA back to the PDIF with Result-Code AVP as "success." The EAP-Payload message also contains the EAP result code with "success." The DEA also contains the IMSI for the user, which is included in the Callback-Id AVP. PDIF uses this IMSI for all subsequent session management functions such as duplicate session detection etc. PDIF also receives the MSK from AAA, which is used for further key computation.
10	PDIF sends the IKE_AUTH Response back to MS with the EAP payload.
11	MS sends the final IKE_AUTH Request for the first authentication with the AUTH payload computed from keys. If the MS plans to do the second authentication, it will include ANOTHER_AUTH_FOLLOWS Notify payload also.

Step	Description
12	<p>PDIF processes the AUTH request and responds with the IKE_AUTH Response with the AUTH payload computed from the MSK. PDIF does not assign any IP address for the MS pending second authentication. The PDIF will include any configuration payloads.</p> <p>a. If PDIF service does not support Multiple-Authentication and ANOTHER_AUTH_FOLLOWS Notify is received, then PDIF sends IKE_AUTH Response with appropriate error and terminate the IKEv2 session, sending INFORMATIONAL (Delete) Request. b. If ANOTHER_AUTH_FOLLOWS Notify payload is present in the IKE_AUTH Request, PDIF allocates the IP address from the locally configured pools. If proxy-mip-required is enabled, then PDIF initiates Proxy-MIP setup to HA by sending P-MIP RRR. PDIF receives the Proxy-MIP RRP, it takes the Home Address (and DNS addresses if any) and sends the IKE_AUTH Response back to MS by including CP payload with Home Address and DNS addresses. In this case, IKEv2 setup will finish at this stage and IPsec tunnel gets established with a Tunnel Inner Address.</p>
13	<p>MS does the second authentication by sending the IKE_AUTH Request with IDi payload to include the NAI. This NAI may be completely different from the NAI used in the first authentication.</p>
14	<p>On receiving the second authentication IKE_AUTH Request, PDIF checks the configured second authentication methods. The second authentication may be either EAP-MD5 (default) or EAP-GTC. The EAP method may be either EAP-Passthru or EAP-Terminated.</p> <p>a. If the configured method is EAP-MD5, PDIF sends the IKE_AUTH Response with EAP payload including challenge. b. If the configured method is EAP-GTC, PDIF sends the IKE_AUTH Response with EAP-GTC payload. MS processes the IKE_AUTH Response:</p> <ul style="list-style-type: none"> • If the MS supports EAP-MD5, and the received method is EAP-MD5, then the MS will take the challenge and compute the response and send IKE_AUTH Request with EAP payload including Challenge and Response. • If the MS does not support EAP-MD5, but EAP-GTC, and the received method is EAP-MD5, the MS sends legacy-Nak with EAP-GTC.
15(a)	<p>PDIF receives the new IKE_AUTH Request from MS.</p> <p>If the original method was EAP-MD5 and MD5 challenge and response is received, PDIF sends RADIUS Access Request with corresponding attributes (Challenge, Challenge Response, NAI, IMSI etc.).</p>
15(b)	<p>If the original method was EAP-MD5 and legacy-Nak was received with GTC, the PDIF sends IKE_AUTH Response with EAP-GTC.</p>
16	<p>PDIF receives Access Accept from RADIUS and sends IKE_AUTH Response with EAP success.</p>
17	<p>PDIF receives the final IKE_AUTH Request with AUTH payload.</p>
18	<p>PDIF checks the validity of the AUTH payload and initiates Proxy-MIP setup request to the Home Agent. If proxy-mip-required is enabled. The HA address may be received from the RADIUS server in the Access Accept (Step 16) or may be locally configured. PDIF may also remember the HA address from the first authentication received in the final DEA message.</p>
19	<p>If proxy-mip-required is disabled, PDIF assigns the IP address from the local pool.</p>
20	<p>PDIF received proxy-MIP RRP and gets the IP address and DNS addresses.</p>
21	<p>PDIF sets up the IPsec tunnel with the home address. On receiving the IKE_AUTH Response MS sends the IKE_AUTH Request with the IPsec tunnel using the received IP address. PDIF sends the IKE_AUTH Response back to MS by including the CP payload with the IP address and optionally the DNS addresses. This completes the setup.</p>

Step	Description
22	PDIF sends a RADIUS Accounting start message.



Important For Proxy-MIP call setup using PAP, the first 14 steps are the same as for CHAP authentication. However, here they deviate because the MS does not support EAP-MD5 authentication, but EAP-GTC. In response to the EAP-MD5 challenge, the MS instead responds with legacy-Nak with EAP-GTC. The diagram below picks up at this point.

Figure 133: Proxy-MIP Call Setup using PAP Authentication

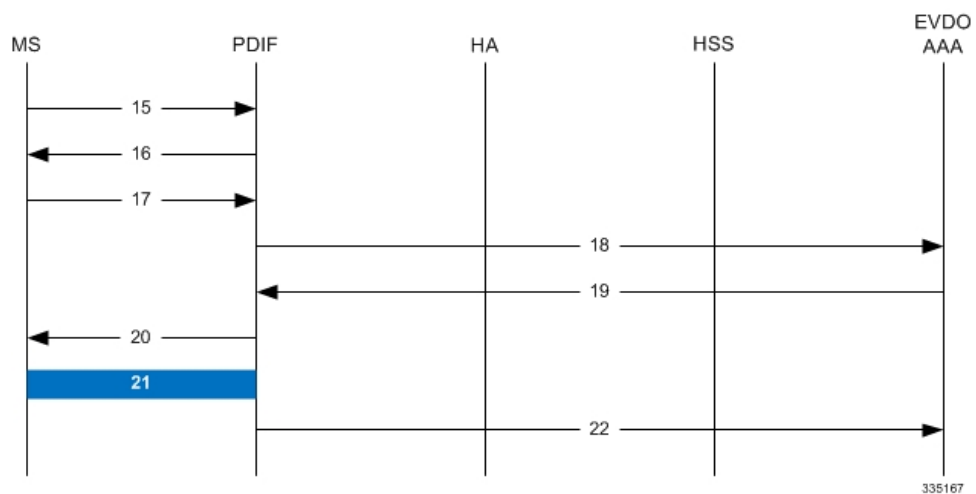

Table 77: Proxy-MIP Call Setup using PAP Authentication

Step	Description
15	MS is not capable of CHAP authentication but PAP authentication, and the MS returns the EAP payload to indicate that it needs EAP-GTC authentication.
16	PDIF then initiates EAP-GTC procedure, and requests a password from MS.
17	MS includes an authentication password in the EAP payload to PDIF.
18	Upon receipt of the password, PDIF sends a RADIUS Access Request which includes NAI in the User-Name attribute and PAP-password.
19	Upon successful authentication, the AAA server returns a RADIUS Access Accept message, which may include Framed-IP-Address attribute.
20	The attribute content in the Access Accept message is encoded as EAP payload with EAP success when PDIF sends the IKE_AUTH Response to the MS.
21	The MS and PDIF now have a secure IPSec tunnel for communication.
22	PDIF sends an Accounting START message.

Configuring Proxy Mobile-IP Support

Support for Proxy Mobile-IP requires that the following configurations be made:



Important Not all commands and keywords/variables may be supported. This depends on the platform type and the installed license(s).

- **FA service(s):** Proxy Mobile IP must be enabled, operation parameters must be configured, and FA-HA security associations must be specified.
- **HA service(s):** FA-HA security associations must be specified.
- **Subscriber profile(s):** Attributes must be configured to allow the subscriber(s) to use Proxy Mobile IP. These attributes can be configured in subscriber profiles stored locally on the system or remotely on a RADIUS AAA server.
- **APN template(s):** Proxy Mobile IP can be supported for every subscriber IP PDP context facilitated by a specific APN template based on the configuration of the APN.



Important These instructions assume that the system was previously configured to support subscriber data sessions as a core network service and/or an HA according to the instructions described in the respective product administration guide.

Configuring FA Services

Use this example to configure an FA service to support Proxy Mobile IP:

```

configure
  context <context_name>
  fa-service <fa_service_name>
  proxy-mip allow
  proxy-mip max-retransmissions <integer>
  proxy-mip retransmission-timeout <seconds>
  proxy-mip renew-percent-time percentage
  fa-ha-spi remote-address { ha_ip_address | ip_addr_mask_combo } spi-number number
  { encrypted secret enc_secret | secret secret } [ description string ] [
hash-algorithm { hmac-md5 | md5 | rfc2002-md5 } | replay-protection {
timestamp | nonce } | timestamp-tolerance tolerance ]
  authentication mn-ha allow-noauth
  end

```

Notes:

- The **proxy-mip max-retransmissions** command configures the maximum number re-try attempts that the FA service is allowed to make when sending Proxy Mobile IP Registration Requests to the HA.
- **proxy-mip retransmission-timeout** configures the maximum amount of time allowed by the FA for a response from the HA before re-sending a Proxy Mobile IP Registration Request message.

- **proxy-mip renew-percent-time** configures the amount of time that must pass prior to the FA sending a Proxy Mobile IP Registration Renewal Request.

Example

If the advertisement registration lifetime configured for the FA service is 900 seconds and the renew-time is configured to 50, then the FA requests a lifetime of 900 seconds in the Proxy MIP registration request. If the HA grants a lifetime of **600** seconds, then the FA sends the Proxy Mobile IP Registration Renewal Request message after **300** seconds have passed.

- Use the **fa-ha-spi remote-address** command to modify configured FA-HA SPIs to support Proxy Mobile IP. Refer to the *Command Line Interface Reference* for the full command syntax.



Important Note that FA-HA SPIs **must** be configured for the Proxy-MIP feature to work, while it is optional for regular MIP.

- Use the **authentication mn-ha allow-noauth** command to configure the FA service to allow communications from the HA without authenticating the HA.

Verify the FA Service Configuration

Use the following command to verify the configuration of the FA service:

```
show fa-service name <fa_service_name>
```

Notes:

- Repeat this example as needed to configure additional FA services to support Proxy-MIP.
- Save your configuration to flash memory, an external memory device, and/or a network location using the Exec mode command **save configuration**. For additional information on how to verify and save configuration files, refer to the *System Administration Guide* and the *Command Line Interface Reference*.

Proceed to the optional [Configuring Proxy MIP HA Failover, on page 882](#) to configure Proxy MIP HA Failover support or skip to the *Configuring HA Services* to configure HA service support for Proxy Mobile IP.

Configuring Proxy MIP HA Failover

Use this example to configure Proxy Mobile IP HA Failover:



Important This configuration in this section is optional.

When configured, Proxy MIP HA Failover provides a mechanism to use a specified alternate Home Agent for the subscriber session when the primary HA is not available. Use the following configuration example to configure the Proxy MIP HA Failover:

```
configure
context <context_name>
```

```

fa-service <fa_service_name>
proxy-mip ha-failover [ max-attempts <max_attempts> |
num-attempts-before-switching <num_attempts> | timeout <seconds> ]

```

Notes:

- Save your configuration to flash memory, an external memory device, and/or a network location using the Exec mode command **save configuration**. For additional information on how to verify and save configuration files, refer to the *System Administration Guide* and the *Command Line Interface Reference*.

Configuring Subscriber Profile RADIUS Attributes

In order for subscribers to use Proxy Mobile IP, attributes must be configured in their user profile or in an APN for 3GPP service. As mentioned previously, the subscriber profiles can be located either locally on the system or remotely on a RADIUS AAA server.

This section provides information on the RADIUS attributes that must be used and instructions for configuring locally stored profiles/APNs in support of Proxy Mobile IP.



Important Instructions for configuring RADIUS-based subscriber profiles are not provided in this document. Please refer to the documentation supplied with your server for further information.

Configuring Subscriber Profile RADIUS Attributes

In order for subscribers to use Proxy Mobile IP, attributes must be configured in their user profile or in an APN for 3GPP service. As mentioned previously, the subscriber profiles can be located either locally on the system or remotely on a RADIUS AAA server.

This section provides information on the RADIUS attributes that must be used and instructions for configuring locally stored profiles/APNs in support of Proxy Mobile IP.



Important Instructions for configuring RADIUS-based subscriber profiles are not provided in this document. Please refer to the documentation supplied with your server for further information.

RADIUS Attributes Required for Proxy Mobile IP

The following table describes the attributes that must be configured in profiles stored on RADIUS AAA servers in order for the subscriber to use Proxy Mobile IP.

Table 78: Required RADIUS Attributes for Proxy Mobile IP

Attribute	Description	Values
SN-Subscriber-Permission OR SN1-Subscriber-Permission	Indicates the services allowed to be delivered to the subscriber. For Proxy Mobile IP, this attribute must be set to Simple IP.	<ul style="list-style-type: none"> • None (0) • Simple IP (0x01) • Mobile IP (0x02) • Home Agent Termina Mobile IP (0x04)

Attribute	Description	Values
SN-Proxy-MIP OR SN1-Proxy-MIP	Specifies if the configured service will perform compulsory Proxy-MIP tunneling for a Simple-IP subscriber. This attribute must be enabled to support Proxy Mobile IP.	<ul style="list-style-type: none"> • Disabled - do not perform compulsory Proxy-MIP (0) • Enabled - perform compulsory Proxy-MIP (1)
SN-Simultaneous-SIP-MIP OR SN1-Simultaneous-SIP-MIP	Indicates whether or not a subscriber can simultaneously access both Simple IP and Mobile IP services. Note Regardless of the configuration of this attribute, the FA facilitating the Proxy Mobile IP session will not allow simultaneous Simple IP and Mobile IP sessions for the MN.	<ul style="list-style-type: none"> • Disabled (0) • Enabled (1)
SN-PDSN-Handoff-Req-IP-Addr OR SN1-PDSN-Handoff-Req-IP-Addr	Specifies whether or not the system should reject and terminate the subscriber session when the proposed address in IPCP by the mobile does not match the existing address that was granted by the chassis during an Inter-chassis handoff. This can be used to disable the acceptance of 0.0.0.0 as the IP address proposed by the MN during the IPCP negotiation that occurs during an Inter-chassis handoff. This attribute is disabled (do not reject) by default.	<ul style="list-style-type: none"> • Disabled - do not reject (0) • Enabled - reject (1)
3GPP2-MIP-HA-Address	This attribute sent in an Access-Accept message specifies the IP Address of the HA. Multiple attributes can be sent in Access Accept. However, only the first two are considered for processing. The first one is the primary HA and the second one is the secondary (alternate) HA used for HA Failover.	IPv4 Address

Configuring Local Subscriber Profiles for Proxy-MIP on a PDSN

This section provides information and instructions for configuring local subscriber profiles on the system to support Proxy Mobile IP on a PDSN.

configure

```

context <context_name>
subscriber name <subscriber_name>
permission pdsn-simple-ip
proxy-mip allow
inter-pdsn-handoff require ip-address
mobile-ip home-agent <ha_address>
<optional> mobile-ip home-agent <ha_address> alternate
ip context-name <context_name>
end

```

Verify that your settings for the subscriber(s) just configured are correct.

```
show subscribers configuration username <subscriber_name>
```

Notes:

- Configure the system to enforce the MN's use of its assigned IP address during IPCP negotiations resulting from inter-PDSN handoffs. Sessions re-negotiating IPCP will be rejected if they contain an address other than that which was granted by the PDSN (i.e. 0.0.0.0). This rule can be enabled by entering the **inter-pdsn-handoff require ip-address** command.
- Optional: If you have enabled the Proxy-MIP HA Failover feature, use the **mobile-ip home-agent ha_address** alternate command to specify the secondary, or alternate HA.
- Repeat this example as needed to configure additional FA services to support Proxy-MIP.
- Save your configuration to flash memory, an external memory device, and/or a network location using the Exec mode command **save configuration**. For additional information on how to verify and save configuration files, refer to the *System Administration Guide* and the *Command Line Interface Reference*.

Configuring Local Subscriber Profiles for Proxy-MIP on a PDIF

This section provides instructions for configuring local subscriber profiles on the system to support Proxy Mobile IP on a PDIF.

```
configure
context <context-name>
subscriber name <subscriber_name>
proxy-mip require
```

Note

subscriber_name is the name of the subscriber and can be from 1 to 127 alpha and/or numeric characters and is case sensitive.

Configuring Default Subscriber Parameters in Home Agent Context

It is very important that the subscriber default, configured in the same context as the HA service, has the name of the destination context configured. Use the configuration example below:

```
configure
context <context_name>
ip context-name <context_name>
end
```

Save your configuration to flash memory, an external memory device, and/or a network location using the Exec mode command **save configuration**. For additional information on how to verify and save configuration files, refer to the *System Administration Guide* and the *Command Line Interface Reference*.

Configuring APN Parameters

This section provides instructions for configuring the APN templates to support Proxy Mobile IP for all IP PDP contexts they facilitate.



Important This is an optional configuration. In addition, attributes returned from the subscriber's profile for non-transparent IP PDP contexts take precedence over the configuration of the APN.

These instructions assume that you are at the root prompt for the Exec mode:

```
[local]host_name
```

Step 1 Enter the configuration mode by entering the following command:

```
configure
```

The following prompt appears:

```
[local]host_name(config)
```

Step 2 Enter context configuration mode by entering the following command:

```
context <context_name>
```

context_name is the name of the system destination context designated for APN configuration. The name must be from 1 to 79 alpha and/or numeric characters and is case sensitive. The following prompt appears:

```
[<context_name>]host_name(config-ctx)
```

Step 3 Enter the configuration mode for the desired APN by entering the following command:

```
apn <apn_name>
```

apn_name is the name of the APN that is being configured. The name must be from 1 to 62 alpha and/or numeric characters and is not case sensitive. It may also contain dots (.) and/or dashes (-). The following prompt appears:

```
[<context_name>]host_name(config-apn)
```

Step 4 Enable proxy Mobile IP for the APN by entering the following command:

```
proxy-mip required
```

This command causes proxy Mobile IP to be supported for all IP PDP contexts facilitated by the APN.

Step 5 *Optional.* GGSN/FA MN-NAI extension can be skipped in MIP Registration Request by entering following command:

```
proxy-mip null-username static-homeaddr
```

This command will enable the accepting of MIP Registration Request without NAI extensions in this APN.

Step 6 Return to the root prompt by entering the following command:

```
end
```

The following prompt appears:

```
[local]host_name
```

Step 7 Repeat *step 1* through *step 6* as needed to configure additional APNs.

Step 8 Verify that your APNs were configured properly by entering the following command:

```
show apn { all | name } <apn_name> }
```

The output is a detailed listing of configured APN parameter settings.

Step 9 Save your configuration to flash memory, an external memory device, and/or a network location using the Exec mode command **save configuration**. For additional information on how to verify and save configuration files, refer to the *System Administration Guide* and the *Command Line Interface Reference*.



CHAPTER 48

Revised Marking for Subscriber Traffic

- [Feature Summary and Revision History, on page 887](#)
- [Feature Description, on page 888](#)
- [How It Works, on page 888](#)
- [Configuring Revised Marking for Subscriber Traffic, on page 889](#)
- [Configuring 802.1p and MPLS EXP Marking for User Data Traffic, on page 890](#)
- [Monitoring and Troubleshooting Revised Marking for Subscriber Traffic, on page 893](#)

Feature Summary and Revision History

Summary Data

Applicable Product(s) or Functional Area	P-GW
Applicable Platform(s)	<ul style="list-style-type: none"> • ASR 5500 • VPC-DI • VPC-SI
Feature Default	<ul style="list-style-type: none"> • Disabled - Configuration Required
Related Changes in This Release	Not applicable
Related Documentation	<ul style="list-style-type: none"> • <i>Command Line Interface Reference</i> • <i>P-GW Administration Guide</i>

Revision History

Revision Details	Release
P-GW supports configuration of 802.1p and MPLS Experimental (EXP) bits marking for user data traffic. This feature is fully qualified in this release.	21.20.2

Revision Details	Release
<p>In this release P-GW supports configuration of 802.1p and MPLS Experimental (EXP) bits marking for user data traffic.</p> <p>Important This feature is not fully qualified in this release, and is available only for testing purposes. For more information, contact your Cisco Account Representative.</p>	21.20

Feature Description

802.1p/MPLS EXP marking helps in providing QoS treatment by prioritizing traffic at L2 level.

Currently, data traffic for different access types, such as GGSN, eHRPD, P-GW, and S-GW, refer to the QCI-QoS table and configure the appropriate 802.1p or MPLS-EXP (L2 QoS) markings based on the internal-qos value associated with particular row. However, the usage of internal-qos from the QCI-QoS table is not configurable and uses the default values. In addition, L2 QoS (802.1p/MPLS EXP) marking is not supported in GGSN, SAEGW, and GTPv1/eHRPD calls on P-GW.

With this feature, you can:

- Configure internal priority in QCI-mapping table for the GGSN, GTPv1 P-GW, and SAEGW calls.
- Mark subscriber traffic with either 802.1p or MPLS-EXP to enable or disable L2 marking. A new CLI command has been introduced to support service specific configuration to mark subscriber traffic. This L2 marking can be decided based on QCI and DSCP marking together or solely based on DSCP marking.

Limitations

- This feature does not control the behavior of the control packets. The control packets (GTP-C) continue to get L2 marked based on DSCP derived L2 marking.
- This feature is not supported on standalone GGSN. It is supported on GnGp-GGSN node.

How It Works

You can configure internal priority in QCI-mapping table for the GGSN, GTPv1 P-GW, and SAEGW calls. You can also mark subscriber traffic with either 802.1p or MPLS-EXP to enable or disable L2 marking. To do this, use the CLI command to configure service specific configuration to mark subscriber traffic. This L2 marking can be decided based on QCI and DSCP marking together or solely based on DSCP marking.

Behavior Changes for Different Services

This section describes behavior of this feature for different services. Please see the *Command Changes* section for more information on the CLI command options and its behavior:

GGSN/P-GW GTPv1 Calls:

Previous Behavior: Earlier, the traffic was not marked for data path. This was default behavior for GGSN.

New Behavior: A new CLI command has been introduced to mark the traffic based on:

- QCI-Derived
- DSCP-Derived
- None

If the no or default option of the CLI command is used, then the traffic is not marked. When the feature is not enabled, traffic is not marked.

P-GW GTPv2, S-GW, SAEGW Calls:

Previous Behavior: The QCI-QoS mapping feature used internal-QoS for L2 marking, which in turn uses QCI-Derived marking for data traffic. This was the default behavior for P-GW, S-GW, and SAEGW calls.

New Behavior: With this feature, the traffic is marked based on:

- QCI-Derived
- DSCP-Derived
- None

If the no or default option of the CLI command is used, then the traffic is not marked and the default behavior is executed. When the feature is not enabled, traffic is not marked.

Configuring Revised Marking for Subscriber Traffic

By default, the traffic data path is supported with GGSN.. The internal priority can be configured in QCI-mapping table for the GGSN, GTPv1 P-GW, and SAEGW calls. Subscriber traffic can also be marked with either 802.1p or MPLS-EXP to enable or disable L2 marking. To do this, use the CLI command to configure service specific configuration to mark subscriber traffic. This L2 marking can be decided based on QCI and DSCP marking together or solely based on DSCP marking.

Configuring Internal Priority

To configure internal priority in the QCI-mapping table for the GGSN, GTPv1 P-GW, and SAEGW calls, use the following service specific configuration. This command in the GGSN service configuration overrides the behavior of QCI-QoS-mapping for data packets only.

```
configure
  context context_name
    ggsn-service service_name
      internal-qos data { dscp-derived | none | qci-derived }
      { no | default } internal-qos data { dscp-derived | none |
qci-derived }
    end
```

Notes:

- **no:** Disables the specified functionality.
- **default:** Disables the functionality.

- **dscp-derived:** Data packets are marked at Layer 2 based on DSCP configured in qci-qos mapping table, then if DSCP is not configured in the qci-qos mapping table then data packets are not marked.
- **none:** Data packets are not marked with Layer 2 (MPLS EXP/802.1P) marking.
- **qci-derived:** Data packets are marked at Layer 2 based on internal-qos-priority configured in qci-qos mapping table. If internal-qos priority is not configured in the qci-qos mapping table, then the data packets are not marked.

Verifying the Configuration

The configuration of this feature can be verified using the following commands from the `exec` mode:

- **show configuration**
- **show service-type { all | name service_name }**

Please see the *Monitoring and Troubleshooting Revised Marking for Subscriber Traffic* section for the command output.

Configuring 802.1p and MPLS EXP Marking for User Data Traffic

This section describes how to configure the 802.1p and MPLS Experimental (EXP) bits marking for user data traffic. Configuring the feature consists of the following tasks:

1. Configure ip-dscp-iphb-mapping.
2. Configure L2-mapping
3. Configure qci-qos-mapping.
4. Associate the l2-mapping in Egress context.
5. Associate the l2-mapping in Igress context.
6. Associate internal-qos data in P-GW and S-GW service

Configure ip-dscp-iphb-mapping

Use the following example to access *QOS Profile Configuration Mode* and configure ip-dscp-iphb-mapping.

```
configure
  qos ip-dscp-iphb-mapping dscp Value internal-priority cos value
end
```

Notes:

- *qos ip-dscp-iphb-mapping dscp* : Creates a QOS profile.
- **dscp** : Specify dscp mapping with Hexadecimal value between 0x0 and 0x3F.
- **internal-priority cos** : Define the Class of Service (cos) value between 0x0 and 0x7.

Configure L2-mapping

Use the following example to access *QOS L2 Mapping Configuration Mode* and configure L2 mapping.

```
configure
  qos l2-mapping-table name { name map_table_name | system-default }
    internal-priority cos class_of_service_value color color_value [ 802.1p-value
802.1p_value ] [ mpls-tc mpls_tc_value ]
  end
```

Notes:

- **qos l2-mapping-table name** : Maps qos from internal qos to l2 values.
- **internal-priority cos** : Maps internal QoS priority with Class of Service (COS) values.
 - *class_of_service_value*: Specify a Hexadecimal number between 0x0 and 0x7.
 - **802.1p-value** : Maps to a 802.1p value and *.802.1p_value* must be a Hexadecimal number between 0x0 and 0xF.
 - **mpls-tc mpls_tc_value**: Maps to an MPLS traffic class. *mpls_tc_value* must be a Hexadecimal number between 0x0 and 0x7.

Configure qci-qos

Use the following commands to configure qci-qos mapping.

Configure

```
qci-qos-mapping name
  qci num [ arp-priority-level arp_value ] [ downlink [ encaps-header
{ copy-inner | dscp-marking dscp-marking-value } ] [ internal-qos
priority priority ] [ user-datagram dscp-marking dscp-marking-value ]
] [ uplink [ downlink] [ encaps-header { copy-inner | dscp-marking
dscp-marking-value } ] [ internal-qos priority priority ] [ user-datagram
dscp-marking dscp-marking-value ] ]
  end
```

Notes:

- **qci-qos-mapping** : Maps internal QoS priority with Class of Service (CoS) value.
- **qci num**: Specifies the non-standard, operator-defined QCI value to be enabled.
- **arp-priority-level** : Specifies the address retention priority (ARP) priority level.
- **downlink**: Configures parameters for downlink traffic.
- **encaps-header { copy-inner | dscp-marking dscp-marking-value}**: Specifies that the DSCP marking must be set on the encapsulation header for IP-in-IP, GRE, or GTP encapsulation.
 - **copy-inner**: Specifies that the DSCP marking is to be acquired from the UDP headers within the encapsulation.
 - **dscp-marking dscp-marking-value**: Specifies that the DSCP marking is to be defined by this keyword.

dscp-marking-value is expressed as a hexadecimal number from 0x00 through 0x3F.

- **uplink**: Configures parameters for uplink traffic.
- **internal-qos priority *priority***: Sets the internal QoS. These get resolved in L2 values.
- **user-datagram dscp-marking *dscp-marking-value***: Specifies that the IP DSCP marking is to be defined by this keyword. *dscp-marking-value* is expressed as a hexadecimal number from 0x00 through 0x3F.

Associate L2-mapping table

Use the following commands to associate L2 mapping table in egress context and ingress context.

```
configure
context egress context_name | ingress context_name
associate l2-mapping-table { name table_name
exit
context ingress context_name
associate l2-mapping-table { name table_name
end
```

- **associate l2-mapping-table**: Maps qos from internal qos to l2 values.
- **{ name *table_name***: Specifies the name of table to map qos from internal qos to l2 values. *table_name* must be a alphanumeric string of size 1 to 80.

Associate internal-qos-data in a P-GW and S-GW Service

Use the following commands to associate internal-qos-data in a P-GW and S-GW service.

```
configure
context context_name
pgw-service service_name
internal-qos data { qci-derived | dscp-derived | none }
{ no | default } internal-qos data { dscp-derived | none |
qci-derived }
exit
sgw-service service_name
internal-qos data { qci-derived | dscp-derived | none }
{ no | default } internal-qos data { dscp-derived | none |
qci-derived }
end
```

Notes:

- **no**: Disables the specified functionality.
- **default**: Disables the functionality.
- **dscp-derived**: Data packets are marked at Layer 2 based on DSCP configured in qci-qos mapping table, then if DSCP is not configured in the qci-qos mapping table then data packets are not marked.
- **none**: Data packets are not marked with Layer 2 (MPLS EXP/802.1P) marking.

- **qci-derived:** Data packets are marked at Layer 2 based on internal-qos-priority configured in qci-qos mapping table. If internal-qos priority is not configured in the qci-qos mapping table, then the data packets are not marked.

Monitoring and Troubleshooting Revised Marking for Subscriber Traffic

The following section describes commands available to monitor Revised Marking for Subscriber Traffic.

Internal Priority Show Commands

The following section describes commands available to monitor Internal Priority.

show configuration

This command displays the following output:

- When **internal-qos data** is configured as **none**:

```
internal-qos data none
```
- When **internal-qos data** is configured as **qci-derived**:

```
internal-qos data qci-derived
```
- When **internal-qos data** is configured as **dscp-derived**:

```
internal-qos data dscp-ds-derived
```
- When **internal-qos data** is **not configured**:

```
no internal-qos data
```

show service-type { all | name *service_name* }

This command displays the following output:

- When **internal-qos data** is configured as **none**:

```
Internal QoS Application:    Enabled
Internal QoS Policy:        None
```
- When **internal-qos data** is configured as **qci-derived**:

```
Internal QoS Application:    Enabled
Internal QoS Policy:        QCI Derived
```
- When **internal-qos data** is configured as **dscp-derived**:

```
Internal QoS Application:    Enabled
Internal QoS Policy:        DSCP Derived
```
- When **internal-qos data** is **not configured**:

```
show service-type { all | name service_name }
```

```
Internal QoS Application:      Backward-compatible
```



CHAPTER 49

Rf Interface Support

This chapter provides an overview of the Diameter Rf interface and describes how to configure the Rf interface.

Rf interface support is available on the Cisco system for the following products:

- Gateway GPRS Support Node (GGSN)
- Proxy Call Session Control Function (P-CSCF)
- Packet Data Network Gateway (P-GW)
- Serving Call Session Control Function (S-CSCF)



Important The Rf interface is not supported on the S-GW.

It is recommended that before using the procedures in this chapter you select the configuration example that best meets your service model, and configure the required elements for that model as described in the administration guide for the product that you are deploying.

This chapter includes the following topics:

- [Introduction, on page 895](#)
- [Feature Summary and Revision History, on page 898](#)
- [Features and Terminology, on page 899](#)
- [How it Works, on page 912](#)
- [Configuring Rf Interface Support, on page 914](#)

Introduction

The Rf interface is the offline charging interface between the Charging Trigger Function (CTF) (for example, P-GW, P-CSCF) and the Charging Collection Function (CCF). The Rf interface specification for LTE/GPRS/eHRPD offline charging is based on 3GPP TS 32.299 V8.6.0, 3GPP TS 32.251 V8.5.0 and other 3GPP specifications. The Rf interface specification for IP Multimedia Subsystem (IMS) offline charging is based on 3GPP TS 32.260 V8.12.0 and 3GPP TS 32.299 V8.13.0.

Offline charging is used for network services that are paid for periodically. For example, a user may have a subscription for voice calls that is paid monthly. The Rf protocol allows the CTF (Diameter client) to issue offline charging events to a Charging Data Function (CDF) (Diameter server). The charging events can either be one-time events or may be session-based.

The system provides a Diameter Offline Charging Application that can be used by deployed applications to generate charging events based on the Rf protocol. The offline charging application uses the base Diameter protocol implementation, and allows any application deployed on chassis to act as CTF to a configured CDF.

In general, accounting information from core network elements is required to be gathered so that the billing system can generate a consolidated record for each rendered service.

The CCF with the CDF and Charging Gateway Function (CGF) will be implemented as part of the core network application. The CDF function collects and aggregates Rf messages from the various CTFs and creates CDRs. The CGF collects CDRs from the CDFs and generates charging data record files for the data mediation/billing system for billing.

Offline Charging Architecture

The following diagram provides the high level charging architecture as specified in 3GPP 32.240. The interface between CSCF, P-GW and GGSN with CCF is Rf interface. Rf interface for EPC domain is as per 3GPP standards applicable to the PS Domain (e.g. 32.240, 32.251, 32.299, etc.).

Figure 134: Charging Architecture

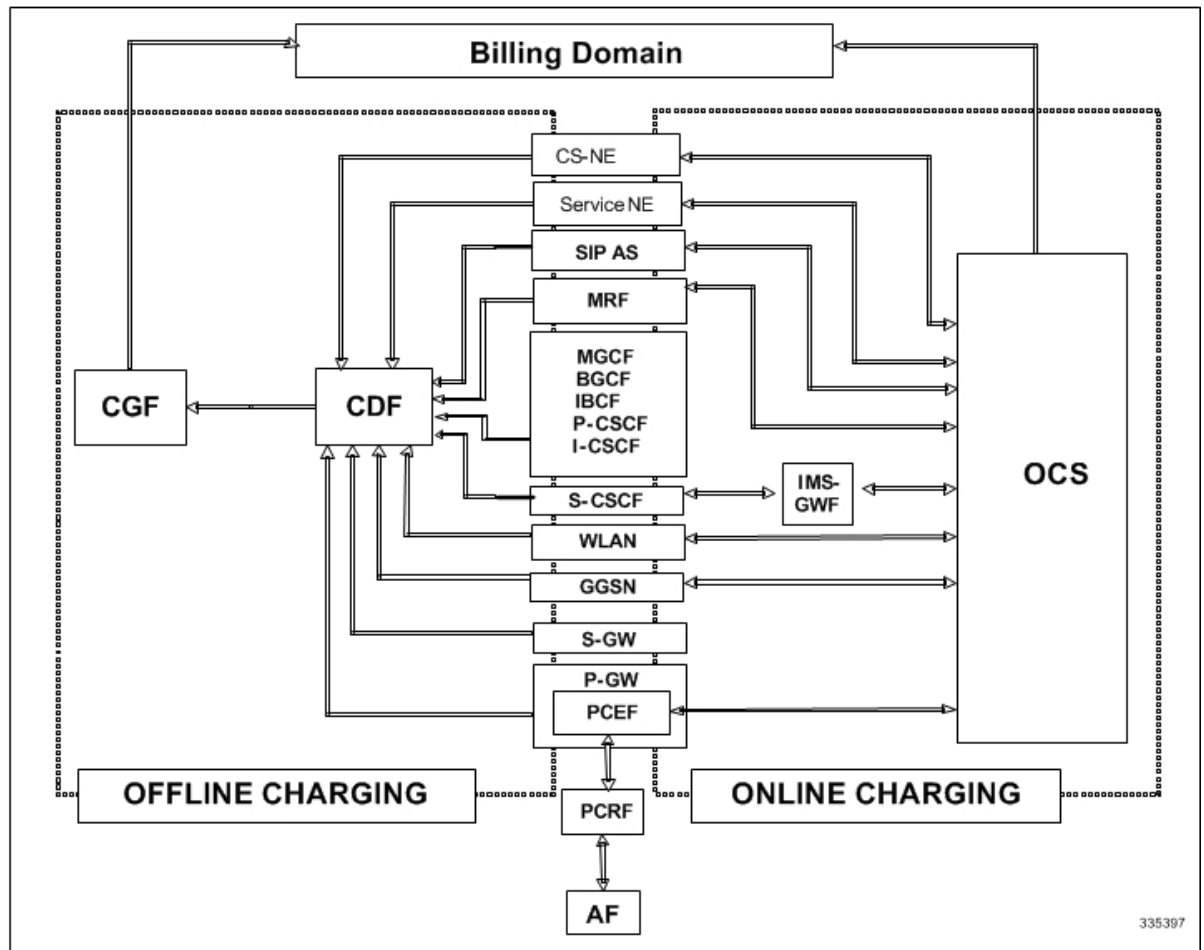

The following figure shows the Rf interface between CTF and CDF.

Figure 135: Logical Offline Charging Architecture

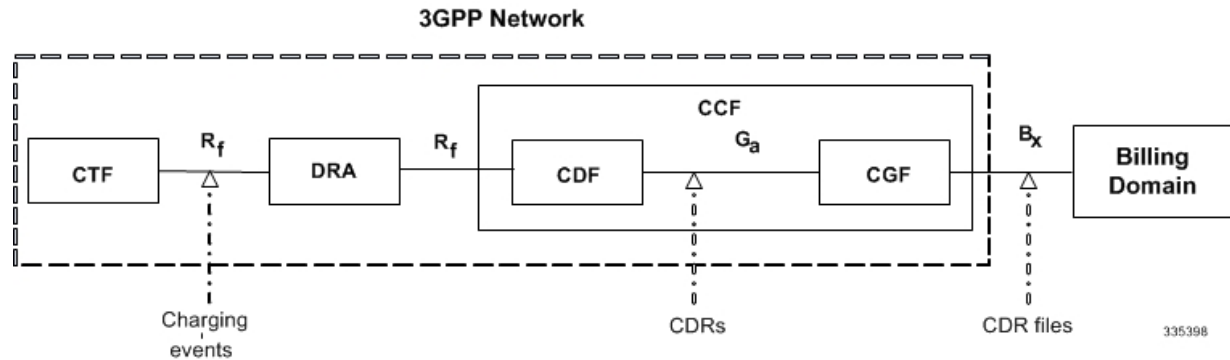

The Rf offline charging architecture mainly consists of three network elements CCF, CTF and Diameter Dynamic Routing Agent (DRA).

Charging Collection Function

The CCF implements the CDF and CGF. The CCF will serve as the Diameter Server for the Rf interface. All network elements supporting the CTF function should establish a Diameter based Rf Interface over TCP connections to the DRA. The DRA function will establish Rf Interface connection over TCP connections to the CCF.

The CCF is primarily responsible for receipt of all accounting information over the defined interface and the generation of CDR (aka UDRs and FDRs) records that are in local storage. This data is then transferred to the billing system using other interfaces. The CCF is also responsible for ensuring that the format of such CDRs is consistent with the billing system requirements. The CDF function within the CCF generates and CGF transfers the CDRs to the billing system.

The CDF function in the CCF is responsible for collecting the charging information and passing it on to the appropriate CGF via the GTP' based interface per 3GPP standards. The CGF passes CDR files to billing mediation via SCP.

Charging Trigger Function

The CTF will generate CDR records and passes it onto CCF. When a P-GW service is configured as CTF, then it will generate Flow Data Record (FDR) information as indicated via the PCRF. The P-GW generates Rf messages on a per PDN session basis. There are no per UE or per bearer charging messages generated by the P-GW.

The service data flows within IP-CAN bearer data traffic is categorized based on a combination of multiple key fields (Rating Group, Rating Group and Service -Identifier). Each Service-Data-Container captures single bi-directional flow or a group of single bidirectional flows as defined by Rating Group or Rating Group and Service-Identifier.

Dynamic Routing Agent

The DRA provides load distribution on a per session basis for Rf traffic from CTFs to CCFs. The DRA acts like a Diameter Server to the Gateways. The DRA acts like a Diameter client to CCF. DRA appears to be a CCF to the CTF and as a CTF to the CCF.

The DRA routes the Rf traffic on a per Diameter charging session basis. The load distribution algorithm can be configured in the DRA (Round Robin, Weighted distribution, etc). All Accounting Records (ACRs) in one

Diameter charging session will be routed by the DRA to the same CCF. Upon failure of one CCF, the DRA selects an alternate CCF from a pool of CCFs.

License Requirements

The Rf interface support is a licensed Cisco feature. A separate feature license may be required. Contact your Cisco account representative for detailed information on specific licensing requirements. For information on installing and verifying licenses, refer to the *Managing License Keys* section of the *Software Management Operations* chapter in the *System Administration Guide*.

Supported Standards

Rf interface support is based on the following standards:

- IETF RFC 4006: Diameter Credit Control Application; August 2005
- 3GPP TS 32.299 V9.6.0 (2010-12) 3rd Generation Partnership Project; Technical Specification Group Services and System Aspects; Telecommunication management; Charging management; Diameter charging applications (Release9)

Feature Summary and Revision History

Summary Data

Applicable Product(s) or Functional Area	P-GW
Applicable Platform(s)	<ul style="list-style-type: none"> • ASR 5500 • VPC-DI • VPC-SI
Feature Default	Disabled - Configuration Required
Related Changes in This Release	Not Applicable
Related Documentation	<ul style="list-style-type: none"> • 5G Non Standalone Solution Guide • AAA Interface Administration and Reference • Command Line Interface Reference • MME Administration Guide • Statistics and Counters Reference

Revision History

Revision Details	Release
The StarOS 21.22 is enhanced, where an existing User Location Information (ULI) is sent to the Accounting Record (ACR) Stop message on offline charging (RF) interface for GGSN, P-GW, and SAEGW.	21.22

Features and Terminology

This section describes features and terminology pertaining to Rf functionality.

Offline Charging Scenarios

Offline charging for both events and sessions between CTF and the CDF is performed using the Rf reference point as defined in 3GPP TS 32.240.

Basic Principles

The Diameter client and server must implement the basic functionality of Diameter accounting, as defined by the RFC 3588 Diameter Base Protocol.

For offline charging, the CTF implements the accounting state machine as described in RFC 3588. The CDF server implements the accounting state machine "SERVER, STATELESS ACCOUNTING" as specified in RFC 3588, i.e. there is no order in which the server expects to receive the accounting information.

The reporting of offline charging events to the CDF is managed through the Diameter Accounting Request (ACR) message. Rf supports the following ACR event types:

Table 79: Rf ACR Event Types

Request	Description
START	Starts an accounting session
INTERIM	Updates an accounting session
STOP	Stops an accounting session
EVENT	Indicates a one-time accounting event

ACR types START, INTERIM and STOP are used for accounting data related to successful sessions. In contrast, EVENT accounting data is unrelated to sessions, and is used e.g. for a simple registration or interrogation and successful service event triggered by a network element. In addition, EVENT accounting data is also used for unsuccessful session establishment attempts.



Important The ACR Event Type "EVENT" is supported in Rf CDRs only in the case of IMS specific Rf implementation.

The following table describes all possible ACRs that might be sent from the IMS nodes i.e. a P-CSCF and S-CSCF.

Table 80: Accounting Request Messages Triggered by SIP Methods or ISUP Messages for P-CSCF and S-CSCF

Diameter Message	Triggering SIP Method/ISUP Message
ACR [Start]	SIP 200 OK acknowledging an initial SIP INVITE
	ISUP:ANM (applicable for the MGCF)
ACR [Interim]	SIP 200 OK acknowledging a SIP
	RE-INVITE or SIP UPDATE [e.g. change in media components]
	Expiration of AVP [Acct-Interim-Interval]
	SIP Response (4xx, 5xx or 6xx), indicating an unsuccessful SIP RE-INVITE or SIP UPDATE
ACR [Stop]	SIP BYE message (both normal and abnormal session termination cases)
	ISUP:REL (applicable for the MGCF)
ACR [Event]	SIP 200 OK acknowledging non-session related SIP messages, which are: <ul style="list-style-type: none"> • SIP NOTIFY • SIP MESSAGE • SIP REGISTER • SIP SUBSCRIBE • SIP PUBLISH
	SIP 200 OK acknowledging an initial SIP INVITE
	SIP 202 Accepted acknowledging a SIP REFER or any other method
	SIP Final Response 2xx (except SIP 200 OK)
	SIP Final/Redirection Response 3xx
	SIP Final Response (4xx, 5xx or 6xx), indicating an unsuccessful SIP session set-up
	SIP Final Response (4xx, 5xx or 6xx), indicating an unsuccessful session-unrelated procedure
	SIP CANCEL, indicating abortion of a SIP session set-up

Event Based Charging

In the case of event based charging, the network reports the usage or the service rendered where the service offering is rendered in a single operation. It is reported using the ACR EVENT.

In this scenario, CTF asks the CDF to store event related charging data.

Session Based Charging

Session based charging is the process of reporting usage reports for a session and uses the START, INTERIM & STOP accounting data. During a session, a network element may transmit multiple ACR Interims' depending on the proceeding of the session.

In this scenario, CTF asks the CDF to store session related charging data.

Diameter Base Protocol

The Diameter Base Protocol maintains the underlying connection between the Diameter Client and the Diameter Server. The connection between the client and server is TCP based.

In order for the application to be compliant with the specification, state machines should be implemented at some level within the implementation.

Diameter Base supports the following Rf message commands that can be used within the application.

Table 81: Diameter Rf Messages

Command Name	Source	Destination	Abbreviation
Accounting-Request	CTF	CDF	ACR
Accounting-Answer	CDF	CTF	ACA

There are a series of other Diameter messages exchanged to check the status of the connection and the capabilities.

- **Capabilities Exchange Messages:** Capabilities Exchange Messages are exchanged between the diameter peers to know the capabilities of each other and identity of each other.
 - **Capabilities Exchange Request (CER):** This message is sent from the client to the server to know the capabilities of the server.
 - **Capabilities Exchange Answer (CEA):** This message is sent from the server to the client in response to the CER message.
- **Device Watchdog Request (DWR):** After the CER/CEA messages are exchanged, if there is no more traffic between peers for a while, to monitor the health of the connection, DWR message is sent from the client. The Device Watchdog timer (Tw) is configurable and can vary from 6 through 30 seconds. A very low value will result in duplication of messages. The default value is 30 seconds. On two consecutive expiries of Tw without a DWA, the peer is considered to be down.



Important

DWR is sent only after Tw expiry after the last message that came from the server. Say if there is continuous exchange of messages between the peers, DWR might not be sent if (Current Time - Last message received time from server) is less than Tw.

- **Device Watchdog Answer (DWA):** This is the response to the DWR message from the server. This is used to monitor the connection state.

- Disconnect Peer Request (DPR): This message is sent to the peer to inform to shutdown the connection. There is no capability currently to send the message to the Diameter server.
 - Disconnect Peer Answer (DPA): This message is the response to the DPR request from the peer. On receiving the DPR, the peer sends DPA and puts the connection state to "DO NOT WANT TO TALK TO YOU" state and there is no way to get the connection back except for reconfiguring the peer again.
- A timeout value for retrying the disconnected peer must be provided.

Timer Expiry Behavior

Upon establishing the Diameter connection, an accounting interim timer (AII) is used to indicate the expiration of a Diameter accounting session, and is configurable at the CTF. The CTF indicates the timer value in the ACR-Start, in the Acct-Interim-Interval AVP. The CDF responds with its own AII value (through the DRA), which must be used by the CTF to start a timer upon whose expiration an ACR INTERIM message must be sent. An instance of the AII timer is started in the CCF at the beginning of the accounting session, reset on the receipt of an ACR-Interim and stopped on the receipt of the ACR-Stop. After expiration of the AII timer, ACR INTERIM message will be generated and the timer will be reset and the accounting session will be continued.

Rf Interface Failures/Error Conditions

The current architecture allows for primary and secondary connections or Active-Active connections for each network element with the CDF elements.

DRA/CCF Connection Failure

When the connection towards one of the primary/Active DRAs in CCF becomes unavailable, the CTF picks the Secondary/Active IP address and begins to use that as a Primary.

If no DRA (and/or the CCF) is reachable, the network element must buffer the generated accounting data in non-volatile memory. Once the DRA connection is up, all accounting messages must be pulled by the CDF through offline file transfer.

No Reply from CCF

In case the CTF/DRA does not receive an ACA in response to an ACR, it may retransmit the ACR message. The waiting time until a retransmission is sent, and the maximum number of repetitions are both configurable by the operator. When the maximum number of retransmissions is reached and still no ACA reply has been received, the CTF/DRA sends the ACRs to the secondary/alternate DRA/CCF.

Detection of Message Duplication

The Diameter client marks possible duplicate request messages (e.g. retransmission due to the link failover process) with the T-flag as described in RFC 3588.

If the CDF receives a message that is marked as retransmitted and this message was already received, then it discards the duplicate message. However, if the original of the re-transmitted message was not yet received, it is the information in the marked message that is taken into account when generating the CDR. The CDRs are marked if information from duplicated message(s) is used.

CCF Detected Failure

The CCF closes a CDR when it detects that expected Diameter ACRs for a particular session have not been received for a period of time. The exact behavior of the CCF is operator configurable.

Rf-Gy Synchronization Enhancements

Both Rf (OFCS) and Gy (OCS) interfaces are used for reporting subscriber usage and billing. Since each interface independently updates the subscriber usage, there are potential scenarios where the reported information is not identical. Apart from Quota enforcement, OCS is utilized for Real Time Reporting (RTR), which provides a way to the user to track the current usage and also get notifications when a certain threshold is hit.

In scenarios where Rf (OFCS) and Gy (OCS) have different usage information for a subscriber session, it is possible that the subscriber is not aware of any potential overages until billed (scenario when Rf is more than Gy) or subscriber believes he has already used up the quota whereas his actual billing might be less (scenario when Gy is more than Rf). In an attempt to align both the Rf and Gy reported usage values, release 12.3 introduced capabilities to provide a way to get the reported values on both the interfaces to match as much as possible. However, some of the functionalities were deferred and this feature implements the additional enhancements.

When time/volume quota on the Gy interface gets exhausted, Gy triggers "Service Data Volume Limit" and "Service Data Time Limit". Now in 16.0 via this feature, this behavior is CLI controlled. Based on the CLI command "**trigger-type { gy-sdf-time-limit { cache | immediate } | gy-sdf-unit-limit { cache | immediate } | gy-sdf-volume-limit { cache | immediate } }**" the behavior will be decided whether to send the ACR-Interim immediately or to cache the containers for future transactions. If the CLI for the event-triggers received via Gy is not configured, then those ACR-Interims will be dropped.

The CLI configuration options are provided in policy accounting configuration to control the various Rf messages (ACRs) triggered for sync on this feature.

This release supports the following enhancements:

- Caches containers in scenarios when ACR-I could not be sent and reported to OFCS.
- Triggers ACR to the OFCS when the CCR to the OCS is sent instead of the current implementation of waiting for CCA from OCS.

If an ACR-I could not be sent to the OFCS, the PCEF caches the container record and sends it in the next transaction to the OFCS.

Once a CCR-U was sent out over Gy interface, the containers are closed only after receiving CCA-U successfully. That is, Rf trigger will be sent only after receiving CCA-U message.

For more information on the command associated with this feature, see the *Accounting Policy Configuration Mode Commands* chapter of the *Command Line Interface Reference*.

A common timer based approach is implemented for Rf and Gy synchronization. As part of the new design, Gy and Rf will be check-pointed at the same point of time for periodic as well as for full check-pointing. Thus, the billing records will always be in sync at all times regardless of during an ICSR switchover event, internal events, session manager crashes, inactive Rf/Gy link, etc. This in turn avoids any billing discrepancies.

Cessation of Rf Records When UE is IDLE

The P-GW is not generating Rf records when the UE was identified to be in IDLE state and not sending any data. New CLI configuration command "**session idle-mode suppress-interim**" is provided to enable/disable the functionality at the ACR level to control the behavior of whether an ACR-I needs to be generated or not when the UE is idle and no data is transferred.

That is, this CLI configuration is used to control sending of ACR-I records when the UE is in idle mode and when there is no data to report.

For more information on the command, see the *Accounting Policy Configuration Mode Commands* chapter of the *Command Line Interface Reference*.

QoS Change Scenarios

QOS_CHANGE Trigger in Rf Records During eHRPD-LTE Handoff

The SDC in the generated Rf record does not include QOS_CHANGE trigger during handoff from eHRPD to LTE.

QoS Change for Default Bearer

For a change in the QoS of default bearer, NR SDV containers will not be seen unless the corresponding bearer is torn down. Only QoS change containers are closed/released for the bearer that underwent QoS Change, i.e. the default bearer.

Diameter Rf Duplicate Record Generation

This section describes the overview and implementation of Rf Duplicate Record Generation feature.

This section discusses the following topics for this feature:

- [Feature Description, on page 904](#)
- [Configuring Rf Duplicate Record Generation, on page 906](#)
- [Monitoring and Troubleshooting the Rf Duplicate Record Generation, on page 908](#)

Feature Description

This feature is introduced to support creation and communication of duplicate Rf records to secondary AAA group servers configured for the Rf interface.

To achieve this functionality, the following configurations must be enabled –

- **aaa group** CLI command under APN to configure a maximum of 2 AAA groups - primary and secondary AAA groups, or two different endpoints for Rf Diameter accounting servers
- **diameter accounting duplicate-record** under AAA group to allow Rf duplicate record creation

The **diameter accounting duplicate-record** is a new CLI command introduced in this release for duplicating the Rf START, INTERIM and STOP accounting records.



Important This is a license-controlled CLI command. For more information, contact your Cisco account representative.

In releases prior to 21, gateway allows only one AAA group configuration per APN for Rf accounting. The AAA group is configured to load balance across multiple servers to pass the Rf traffic and also expect an accounting answer. Note that the secondary AAA group configuration is allowed currently but is restricted to only RADIUS accounting.

In release 21 and beyond, the gateway is provided with the ability to configure a secondary AAA group per APN for the Rf interface, and send the duplicate Diameter Rf accounting records to the secondary AAA group servers. The secondary AAA group is used for non-billing purposes only.



Important The failed duplicate records will neither be written to HDD nor added to the archival list.

There is no change in the current behavior with the primary AAA group messages. The primary AAA group is independent of the secondary AAA group, and it has multiple Rf servers configured. When the Rf servers do not respond even after multiple retries as per the applicable configuration, the Rf records are archived and stored in HDD. This behavior continues as is irrespective of the configuration of secondary aaa-group.

Secondary aaa group has a very similar configuration as the primary aaa group except that the new CLI command **diameter accounting duplicate-record** is additionally included to configure the secondary aaa-group. It is also important to note that different Diameter endpoints and a separate set of Rf servers should be provisioned for both primary and secondary AAA groups.

If all the configured servers are down, the request message will be discarded without writing it in HDD or archiving at aaamgr.

The original and duplicate Rf messages use two different aaa-groups and two different Diameter endpoints. Hence, the values for Session-ID AVP will be different. Based on the configuration of primary and secondary endpoints the values for Origin-Host, Origin-Realm, Destination-Realm, and Destination-Host AVPs may be different. Also based on the configuration under policy accounting for inclusion of virtual/gn apn name for secondary group Called-Station-ID AVP might change. All other AVPs will have the same values as with the primary aaa group Rf message.

Also, note that the values such as Acct-Interim-Interval (AII) interval received in ACA from secondary group of AAA servers will be ignored.

Relationships to Other Features

This feature can be used in conjunction with Virtual APN Truncation feature to achieve the desired results.

The Virtual APN Truncation feature is new in release 21. For more information on this feature, see the administration guide for the product you are deploying.

Limitations

The following are the limitations of this feature:

- Only one secondary AAA group can be configured per APN.
- If all the Rf peers under secondary aaa group are down and duplicate Start Record is not sent, then the duplicate Interim and Stop records will also not be sent to any of the secondary aaa group servers even though they arrived later. However if the servers are up and duplicate Start record was sent but the server

did not respond, duplicate Start will be dropped after all the retries. In this case, the duplicate Interim and Stop records may be sent out to the server.

- In cases when duplicate Start record was sent, but during duplicate Interim/Stop record generation peers were not responding/down, after all retries duplicate Interim and Stop records will be dropped and will not be written to HDD.
- Minimal impact to memory and CPU is expected due to the duplicate record generation for every primary Rf record.

Configuring Rf Duplicate Record Generation

The following section provides the configuration commands to enable the Rf duplicate record generation.

Configuring Secondary AAA Group

Use the following configuration commands to configure the secondary AAA group for receiving the duplicate Rf records.

```
configure
  context context_name
    apn apn_name
      aaa group group_name
      aaa secondary-group group_name
    exit
```

Notes:

- **aaa group** *group_name*: Specifies the AAA server group for the APN. *group_name* must be an alphanumeric string of 1 through 63 characters.
- **secondary group** *group_name*: Specifies the secondary AAA server group for the APN. *group_name* must be an alphanumeric string of 1 through 63 characters.

Configuring Duplication of Rf Records

Use the following configuration commands to configure the system to create a secondary feed of Rf records and send them to the secondary AAA group.

```
configure
  context context_name
    aaa group group_name
      diameter accounting duplicate-record
    exit
```

Notes:

- **duplicate-record**: Sends duplicate Rf records to configured secondary AAA group. This keyword is license dependent. For more information, contact your Cisco account representative.
- The default configuration is **no diameter accounting duplicate-record**. By default, this feature is disabled.
- The secondary aaa group must be configured under APN configuration mode before enabling the **diameter accounting duplicate-record** CLI command.

Verifying the Rf Duplicate Record Generation Configuration

Use the following commands to verify the configuration status of this feature.

show configuration

show aaa group all

- or -

show aaa group *group_name*

group_name must be the name of the AAA group specified during the configuration.

This command displays all the configurations that are enabled within the specified AAA group.

The following is a sample configuration of this feature.

```

configure
  context source
    apn domainname.com
      associate accounting-policy policy_accounting_name
      aaa group group1
      aaa secondary-group group2
      exit
    aaa group group1
      diameter accounting dictionary aaa-custom4
      diameter accounting endpoint rf_endpoint1
      diameter accounting server rf_server1 priority 1
      diameter accounting server rf_server2 priority 2
      exit
    aaa group group2
      diameter accounting dictionary aaa-custom4
      diameter accounting endpoint rf_endpoint2
      diameter accounting duplicate-record
      diameter accounting server rf_server3 priority 3
      diameter accounting server rf_server4 priority 4
      exit
    diameter endpoint rf-endpoint1
      use-proxy
      origin host rf-endpoint1.carrier.com address 192.50.50.3
      no watchdog-timeout
      response-timeout 20
      connection retry-timeout 5
      peer rf_server1 realm domainname.com address 192.50.50.4 port 4872
      peer rf_server2 realm domainname.com address 192.50.50.4 port 4873
      exit
    diameter endpoint rf-endpoint2
      use-proxy
      origin host rf-endpoint2.carrier.com address 192.50.50.2
      no watchdog-timeout
      response-timeout 20
      connection retry-timeout 5
      peer rf_server3 realm domainname.com address 192.50.50.5 port 4892
      peer rf_server4 realm domainname.com address 192.50.50.5 port 4893
  end

```

Notes:

- The **diameter accounting duplicate-record** CLI is license specific. So, the corresponding license must be enabled for the CLI command to be configured.
- Both primary and secondary aaa groups are preferred to have different accounting endpoint names.

Monitoring and Troubleshooting the Rf Duplicate Record Generation

This section provides information regarding show commands and/or their outputs in support of this feature.

The following operations can be performed to troubleshoot any failure related to this feature:

- Verify if the feature is enabled using **show configuration** or **show aaa group all** CLI command. If not enabled, configure the diameter accounting duplicate-record CLI command and check if it works.
- Collect the output of **show diameter aaa statistics** command and analyze the debug statistics. Also, check the reported logs, if any. For further analysis, contact Cisco account representative.

show diameter aaa-statistics

The following statistics are added to the output of this show command for duplicate Rf records which were dropped because of the failure in sending the Accounting records instead of adding them to HDD or archival list.

- Duplicate Accounting Records Stats
 - ACR-Start Dropped
 - ACR-Interim Dropped
 - ACR-Stop Dropped

These statistics are maintained per aaamgr instance level. For descriptions of these statistics, see the *Statistics and Counters Reference* guide.

These statistics can also be collected per group basis/server basis for duplicate records i.e. through **show diameter aaa-statistics group** <group_name> and **show diameter aaa-statistics server** <server_name> CLI commands.

Truncation of Virtual APN for Rf Records

This feature enables the truncation of Virtual APN (VAPN) returned by S6b server to be sent to Gx, Gy and Rf interfaces.

Feature Description

Currently there is no way to quickly turn on the Rf accounting to the Data Streaming Service (DSS) server per Virtual APN (S6b-VAPN) without reaching all nodes in the network and provision the Virtual APN on each of them. This feature is implemented to truncate the virtual APN name returned by S6b server with the configured standard delimiters. In this way a single configuration per node can be utilized for all enterprises based on a virtual APN. This approach will significantly reduce the size and time to provision new enterprises with the requested feature.

To achieve this functionality, a configuration is added per APN to enable truncation of S6b-VAPN and also to configure the delimiter(s) where the APN name is to be truncated. Standard delimiters like (.) and (-) are used since APN name supports only these two characters apart from the alphanumeric ones.

If AAA server returns both hyphen and dot delimiters or the same delimiter twice or more as a virtual-apn, then the first delimiter will be considered as a separator. For example, if the AAA server returns the virtual-apn as xyz-cisco.com, then hyphen is the separator.

AAA manager performs the truncation of the Virtual APN name based on the APN configuration and provides the correct APN profile for the truncated APN name. If the truncation is successful, the full virtual APN name will be sent to Gx, Gy and Rf interfaces.

Accounting records are required to support real-time usage notification and device management functionality. So, the **apn-name-to-be-included** CLI command is extended to enable actual APN (Gn-APN) or virtual APN (S6b returned virtual APN) name to be included in Called-Station-ID AVP in the secondary Rf accounting records (secondary server group) under policy accounting configuration. Currently, policy accounting configuration supports sending the Gn-APN/S6b-VAPN in Called-Station-ID for primary Rf server. With this CLI command, this functionality is extended for the secondary Rf server.

A new AAA attribute “Secondary-Called-Station-ID” is added to support sending Gn/Virtual APN name in the Called-Station-ID AVP for duplicate Rf records sent to secondary group Rf server.

Configuring Virtual APN Truncation for Rf Records

The following section provides the configuration commands to enable the Virtual APN Truncation feature for Rf records.

Configuring Gn-APN/VAPN for Rf Accounting

Use the following configuration commands to configure the actual APN or Virtual APN (VAPN) for Rf accounting.

```
configure
  context context_name
    policy accounting policy_name
      apn-name-to-be-included { gn | virtual } [ secondary-group { gn |
virtual } ]
    end
```

Notes:

- **apn-name-to-be-included**: Configures the APN name to be included in the Rf messages for primary server group.
- **secondary-group { gn | virtual }**: Configures the APN name to be included in the Rf messages for secondary server group.
- **gn**: Configures the Gn APN name to be included in the Rf messages.
- **virtual**: Configures the virtual APN name to be included in the Rf messages.
- By default, the apn name to be included in Called-Station-ID AVP is Gn-APN for both primary and secondary Rf server groups.
- If the secondary group configuration is not available, the default behavior is to have Gn APN for secondary Rf group duplicate records.

Configuring Truncation of Virtual APN

Use the following configuration commands to configure the gateway to truncate the APN name returned from S6b interface.

```
configure
  context context_name
    apn apn_name
      virtual-apn { gcdr apn-name-to-be-included { gn | virtual } |
truncate-s6b-vapn delimiter { dot [ hyphen ] | hyphen [ dot ] } }
    end
```

Notes:

- For information on the existing keywords, see the *Command Line Interface Reference* guide.
- **truncate-s6b-vapn**: Allows truncation of virtual APN received from S6b at the configured delimiter character.
- **delimiter { dot [hyphen] | hyphen [dot] }**: Configures the delimiter for truncation of virtual APN received from S6b. If the CLI command is configured, the S6b returned virtual APN will be truncated at the configured delimiter.
 - **dot**: Configures the delimiter to dot (.) for truncation of S6b-VAPN
 - **hyphen**: Configures the delimiter to hyphen (-) for truncation of S6b-VAPN
- Both dot and hyphen delimiters can be configured in the same line or a new line.
- **no virtual-apn truncate-s6b-vapn**: Disables the truncation of virtual APN name. If both delimiters should be disabled at once, use the **no virtual-apn truncate-s6b-vapn** CLI command.

If a particular delimiter needs to be disabled, it should be done explicitly. For example, if the dot delimiter should be disabled, use the **no virtual-apn truncate-s6b-vapn delimiter dot** CLI command.
- By default this feature will be disabled and no delimiter will be configured.
- This CLI command takes effect only when S6b server returns virtual APN name in Authentication Authorization Accept (AAA) message.
- If the separator character is not present in the received S6b virtual APN name, then the whole virtual APN name will be considered for configuration look-up.

Verifying the Virtual APN Truncation Configuration

Use the following command to verify the configuration status of this feature.

```
show configuration apn apn_name
```

apn_name must be the name of the APN specified during the feature configuration.

This command displays all the configurations that are enabled within the specified APN name. The following is a sample output of this show command.

```
[local]st40# show configuration apn intershat
configure
  context ingress
    apn intershat
      pdp-type ipv4 ipv6
      bearer-control-mode mixed
```

```
virtual-apn truncate-s6b-vapn delimiter hyphen
end
```

Monitoring and Troubleshooting the Virtual APN Truncation

This section provides information regarding show commands and/or their outputs in support of this feature.

The following operations can be performed to troubleshoot any failure related to this feature:

- Verify if the feature is enabled using **show configuration apn *apn_name*** CLI command. If not enabled, configure the **virtual-apn truncate-s6b-vapn delimiter { dot [hyphen] | hyphen [dot] }** CLI command and check if it works.
- Collect the output of **show apn statistics** CLI command and analyze the debug statistics. For further assistance, contact Cisco account representative.



Important For P-GW, GGSN and SAEGW services, if the truncation of S6b returned virtual APN name fails and the virtual APN name is not configured, the call will be rejected with ‘unknown-apn-name’ cause.

show apn statistics

This show command uses the existing APN statistics to populate the truncated virtual APN name, if this feature is enabled.

show subscribers ggsn-only full all

The following field added newly to the output of this show command displays the S6b returned full virtual APN name, if this feature is enabled. Otherwise, it displays 'n/a'.

- S6b Returned Virtual APN

show subscribers pgw-only full all

The following field added newly to the output of this show command displays the S6b returned full virtual APN name, if this feature is enabled. Otherwise, it displays 'n/a'.

- S6b Returned Virtual APN

show subscribers saegw-only full all

The following field added newly to the output of this show command displays the S6b returned full virtual APN name, if this feature is enabled. Otherwise, it displays 'n/a'.

- S6b Returned Virtual APN

Accounting Record Stop Location Report

Previous Behavior: When P-GW or S-GW sends new User Location Information (ULI) message in an ACR stop message to Offline Charging System (OFCS) through the Rf interface, the reported location at the end of sessions was not aligning with the expected location reporting. The location used in the Accounting Stop Record (ACR Stop) was inconsistent and during location reporting it caused an ACR stop interim messages rather than the location before the ACR was sent

New Behavior: In the StarOS 21.22 and later releases, an existing User Location Information (ULI) is sent to the Accounting Record (ACR) Stop message on offline charging (RF) interface for GGSN, P-GW, and SAEGW when Delete Session Request is received with a New ULI.

How it Works

This section describes how offline charging for subscribers works with Rf interface support in GPRS/eHRPD/LTE/IMS networks.

The following figure and table explain the transactions that are required on the Diameter Rf interface in order to perform event based charging. The operation may alternatively be carried out prior to, concurrently with or after service/content delivery.

Figure 136: Rf Call Flow for Event Based Charging

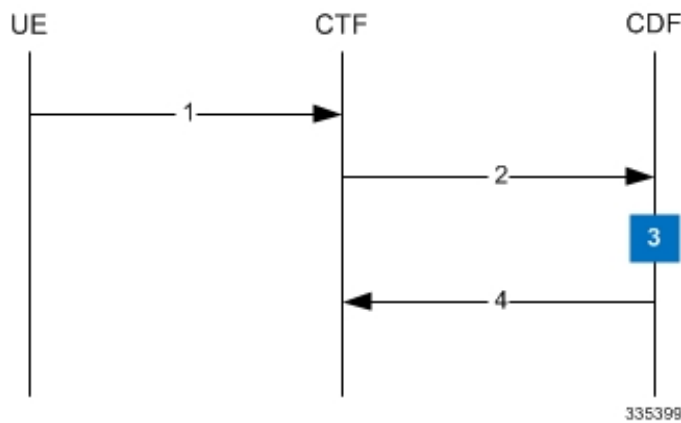

Table 82: Rf Call Flow Description for Event Based Charging

Step	Description
1	The network element (CTF) receives indication that service has been used/delivered.
2	The CTF (acting as Diameter client) sends Accounting-Request (ACR) with Accounting-Record-Type AVP set to EVENT_RECORD to indicate service specific information to the CDF (acting as Diameter server).
3	The CDF receives the relevant service charging parameters and processes accounting request.
4	The CDF returns Accounting-Answer (ACA) message with Accounting-Record-Type AVP set to EVENT_RECORD to the CTF in order to inform that charging information was received.

The following figure and table explain the simple Rf call flow for session based charging.

Figure 137: Rf Call Flow for Session Based Charging

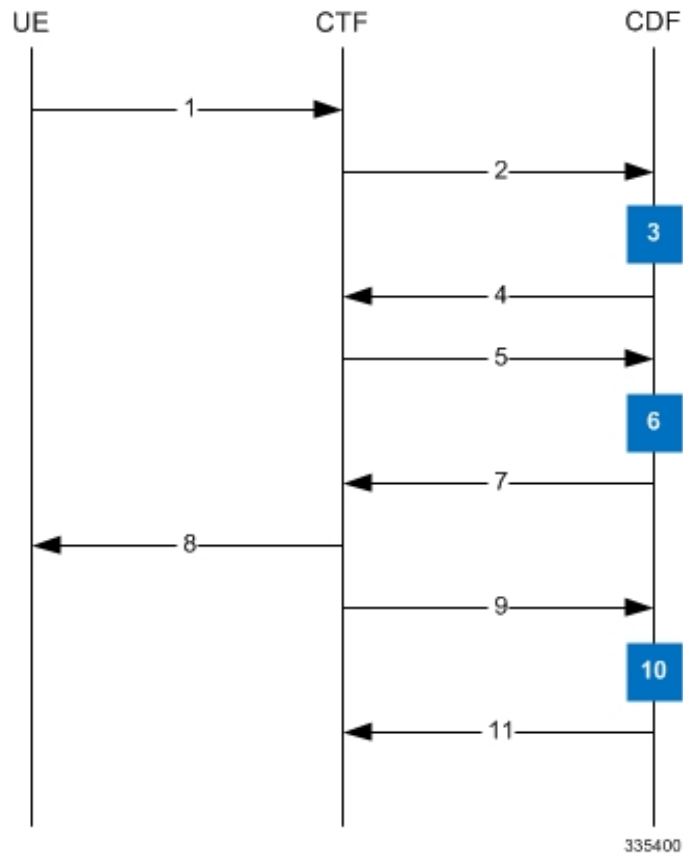

Table 83: Rf Call Flow Description for Session Based Charging

Step	Description
1	The CTF receives a service request. The service request may be initiated either by the user or the other network element.
2	In order to start accounting session, the CTF sends a Accounting-Request (ACR) with Accounting-Record-Type AVP set to START_RECORD to the CDF.
3	The session is initiated and the CDF opens a CDR for the current session.
4	The CDF returns Accounting-Answer (ACA) message with Accounting-Record-Type set to START_RECORD to the CTF and possibly Acct-Interim-Interval AVP (AII) set to non-zero value indicating the desired intermediate charging interval.
5	When either AII elapses or charging condition changes are recognized at CTF, the CTF sends an Accounting-Request (ACR) with Accounting-Record-Type AVP set to INTERIM_RECORD to the CDF.
6	The CDF updates the CDR in question.
7	The CDF returns Accounting-Answer (ACA) message with Accounting-Record-Type set to INTERIM_RECORD to the CTF.

Step	Description
8	The service is terminated.
9	The CTF sends a Accounting-Request (ACR) with Accounting-Record-Type AVP set to STOP_RECORD to the CDF.
10	The CDF updates the CDR accordingly and closes the CDR.
11	The CDF returns Accounting-Answer (ACA) message with Accounting-Record-Type set to STOP_RECORD to the CTF.

Configuring Rf Interface Support

To configure Rf interface support:

1. Configure the core network service as described in this Administration Guide.
2. Enable Active Charging Service (ACS) and create ACS as described in the *Enhanced Charging Services Administration Guide*.



Important The procedures in this section assume that you have installed and configured your chassis including the ECS installation and configuration as described in the *Enhanced Charging Services Administration Guide*.

3. Enable Rf accounting in ACS as described in [Enabling Rf Interface in Active Charging Service, on page 915](#).
4. Configure Rf interface support as described in the relevant sections:
 - [Configuring GGSN / P-GW Rf Interface Support, on page 915](#)
 - [Configuring P-CSCF/S-CSCF Rf Interface Support, on page 922](#)



Important In StarOS versions 19 and later, the Rf interface is not supported on the S-GW.

5. Save your configuration to flash memory, an external memory device, and/or a network location using the Exec mode command **save configuration**. For additional information on how to verify and save configuration files, refer to the *System Administration Guide* and the *Command Line Interface Reference*.



Important Commands used in the configuration examples in this section provide base functionality to the extent that the most common or likely commands and/or keyword options are presented. In many cases, other optional commands and/or keyword options are available. Refer to the *Command Line Interface Reference* for complete information regarding all commands.

Enabling Rf Interface in Active Charging Service

To enable the billing record generation and Rf accounting, use the following configuration:

```
configure
  active-charging service <service_name>
    rulebase <rulebase_name>
      billing-records rf
      active-charging rf { rating-group-override | service-id-override
    }
  end
```

Notes:

- Prior to creating the Active Charging Service (ACS), the **require active-charging** command should be configured to enable ACS functionality.
- The **billing-records rf** command configures Rf record type of billing to be performed for subscriber sessions. Rf accounting is applicable only for dynamic and predefined ACS rules.

For more information on the rules and its configuration, refer to the *ACS Charging Action Configuration Mode Commands* chapter in the *Command Line Interface Reference*.

- The **active-charging rf** command is used to enforce a specific rating group / service identifier on all PCC rules, predefined ACS rules, and static ACS rules for Rf-based accounting. As this CLI configuration is applied at the rulebase level, all the APNs that have the current rulebase defined will inherit the configuration.

For more information on this command, refer to the *ACS Rulebase Configuration Mode Commands* chapter in the *Command Line Interface Reference*.

Configuring GGSN / P-GW Rf Interface Support

To configure the standard Rf interface support for GGSN/P-GW, use the following configuration:

```
configure
  context <context_name>
    apn <apn_name>
      associate accounting-policy <policy_name>
      exit
      policy accounting <policy_name>
        accounting-event-trigger { cgi-sai-change | ecgi-change |
flow-information-change | interim-timeout | location-change | rai-change
| tai-change } action { interim | stop-start }
        accounting-keys qci
        accounting-level { flow | pdn | pdn-qci | qci | sdf | subscriber }
        cc profile index { buckets num | interval seconds | sdf-interval
seconds | sdf-volume { downlink octets { uplink octets } | total octets |
uplink octets { downlink octets } } | serving-nodes num | tariff time1 min
hrs [ time2 min hrs...time4 min hrs ] | volume { downlink octets { uplink octets
} | total octets | uplink octets { downlink octets } } }
        max-containers { containers | fill-buffer }
      end
```

Notes:

- The policy can be configured in any context.
- For information on configuring accounting levels/policies/modes/event triggers, refer to the *Accounting Policy Configuration Mode Commands* chapter in the *Command Line Interface Reference*.
- Depending on the triggers configured, the containers will either be cached or released. In the case of GGSN/P-GW, the containers will be cached when the event trigger is one of the following:
 - QOS_CHANGE
 - FLOW_INFORMATION_CHANGE
 - LOCATION_CHANGE
 - SERVING_NODE_CHANGE
 - SERVICE_IDLE
 - SERVICE_DATA_VOLUME_LIMIT
 - SERVICE_DATA_TIME_LIMIT
 - IP_FLOW_TERMINATION
 - TARIFF_CHANGE

If the event trigger is one of the following, the containers will be released:

- VOLUME_LIMIT
- TIME_LIMIT
- RAT_CHANGE
- TIMEZONE_CHANGE
- PLMN_CHANGE



Important Currently, SDF and flow level accounting are supported in P-GW.

The following assumptions guide the behavior of P-GW, GGSN and CCF for Change-Condition triggers:

- Data in the ACR messages due to change conditions contain the snapshot of all data that is applicable to the interval of the flow/session from the previous ACR message. This includes all data that is already sent and has not changed (e.g. SGSN-Address).
- All information that is in a PDN session/flow up to the point of the Change-Condition trigger is captured (snapshot) in the ACR-Interim messages. Information about the target Time-Zone/ULI/3GPP2-BSID/QoS-Information/PLMN Change/etc will be in subsequent Rf messages.

Table 84: P-GW/GGSN and CCF Behavior for Change-Condition in ACR-Stop and ACR-Interim for LTE/e-HRPD/GGSN

ACR Message	Change-Condition Value	CCF Response to Change-Condition Value			CC Level Population		Comments
		Addition of Container	Partial FDR	Final FDR	PS-Information Level	SDC Level	
Stop	Normal Release	YES	NO	YES	Normal Release	Normal Release	When PDN/IP session closed, C-C in both levels will have Normal Release.

ACR Message	Change-Condition Value	CCF Response to Change-Condition Value			CC Level Population		Comments
		Addition of Container	Partial FDR	Final FDR	PS-Information Level	SDC Level	
None (as this change condition is a counter for the Max Number of Changes in Charging Conditions).	Normal Release	YES	NO	NO	N/A	Normal Release	Flow is closed, SDC is populated and container is added to record. The container for this change condition will be cached by P-GW/GGSN and container will be in ACR Interim/Stop for partial record (Interim), final Release (Stop) or AII trigger (Interim) trigger.
Stop	Abnormal Release	YES	NO	YES	Abnormal Release	Abnormal Release	When PDN/IP session is closed, C-C in both will have Abnormal Release.
None (as this change condition is a counter for the Max Number of Changes in Charging Conditions).	Abnormal Release	YES	NO	NO	N/A	Abnormal Release	Flow is closed, SDC is populated and container is added to record. The container for this change condition will be cached by P-GW/GGSN and container will be in ACR Interim/Stop for partial record (Interim), final Release (Stop) or AII trigger (Interim) trigger.
None (as this change condition is a counter for the Max Number of Changes in Charging Conditions).	QoS-Change	YES	NO	NO	N/A	QoS-Change	The container for change condition will be cached by the P-GW/GGSN and container will be in ACR Interim/Stop for partial record (Interim), final Release (Stop) or AII trigger (Interim) trigger.

ACR Message	Change-Condition Value	CCF Response to Change-Condition Value			CC Level Population		Comments
		Addition of Container	Partial FDR	Final FDR	PS-Information Level	SDC Level	
Interim	Volume Limit	YES	YES	NO	Volume Limit	Volume Limit	For PDN/IP Session Volume Limit. The Volume Limit is configured as part of the Charging profile and the Charging-Characteristics AVP will carry this charging profile that is passed on from the HSS/AAA to P-GW/GGSN through various interfaces. The charging profile will be provisioned in the HS
Interim	Time Limit	YES	YES	NO	Time Limit	Time Limit	For PDN/IP Session Time Limit. The Time Limit is configured as part of the Charging profile and the Charging-Characteristics AVP will carry this charging profile that is passed on from the HSS/AAA to P-GW/GGSN through various interfaces. The charging profile will be provisioned in the HS
None (as this change condition is a counter for the Max Number of Changes in Charging Conditions).	Serving Node Change	YES	NO	NO	N/A	Serving Node Change	The container for this change condition will be cached by the P-GW/GGSN and the container will be in a ACR Interim/Stop state for partial record (Interim), final Record (Stop) or All trigger (Interim) trigger.
Interim	Serving Node PLMN Change	YES	YES	NO	Serving Node PLMN Change	Serving Node PLMN Change	

ACR Message	Change-Condition Value	CCF Response to Change-Condition Value			CC Level Population		Comments
		Addition of Container	Partial FDR	Final FDR	PS-Information Level	SDC Level	
None (as this change condition is a counter for the Max Number of Changes in Charging Conditions).	User Location Change	YES	NO	NO	N/A	User Location Change	This is BSID Char eHRPD. The cont for this change con will be cached by P-GW/GGSN and container will be i ACR Interim/Stop for partial record (Interim), final Re (Stop) or All trigg (Interim) trigger.
Interim	RAT Change	YES	YES	NO	RAT Change	RAT Change	
Interim	UE Timezone Change	YES	YES	NO	UE Timezone change	UE Timezone change	This is not applica eHRPD.
None (as this change condition is a counter for the Max Number of Changes in Charging Conditions).	Tariff Time Change	YES	NO	NO	N/A	Tariff Time Change	Triggered when Tar Time changes. Tar Time Change requ online charging si change. The implementation of Change Condition dependent on implementation of Online Charging u
None (as this change condition is a counter for the Max Number of Changes in Charging Conditions).	Service Idled Out	YES	NO	NO	N/A	Service Idled Out	Flow Idled out. Th container for this c condition will be c by the P-GW/GGS the container will ACR Interim/Stop for partial record (Interim), final Re (Stop) or All trigg (Interim) trigger.

ACR Message	Change-Condition Value	CCF Response to Change-Condition Value			CC Level Population		Comments
		Addition of Container	Partial FDR	Final FDR	PS-Information Level	SDC Level	
None (as this change condition is a counter for the Max Number of Changes in Charging Conditions).	Service Data Volume Limit	YES	NO	NO	N/A	Service Data Volume Limit	Volume Limit reached for a specific flow. The container for this change condition will be cached by the P-GW/GGSN and the container will be in ACR Interim/Stop state for partial record (Interim), final Record (Stop) or All trigger (Interim) trigger.
None (as this change condition is a counter for the Max Number of Changes in Charging Conditions).	Service Data Time Limit	YES	NO	NO	N/A	Service Data Time Limit	Time Limit reached for a specific flow. The container for this change condition will be cached by the P-GW/GGSN and the container will be in ACR Interim/Stop state for partial record (Interim), final Record (Stop) or All trigger (Interim) trigger.

ACR Message	Change-Condition Value	CCF Response to Change-Condition Value			CC Level Population		Comments
		Addition of Container	Partial FDR	Final FDR	PS-Information Level	SDC Level	
Interim	Max Number of Changes in Charging Conditions	YES	YES	NO	YES	YES, Will include SDC that corresponds to the CCs that occurred (Normal Release of Flow, Abnormal Release of Flow, QoS-Change, Serving Node Change, User Location Change, Tariff Time Change, Service Idled Out, Service Data Volume Limit, Service Data Time Limit)	This ACR[Interim] triggered at the ins when the Max Nu of changes in char conditions takes p Max Change Con is applicable for QoS-Change, Service-Idled Out, change, Flow Nor Release, Flow Abr Release, Service D Volume Limit, Ser Data Time Limit, Timer ACR Interi Service Node Char only. The Max Nu of Changes in Cha Conditions is set a Example assuming flow in the PDN Se [1] Max Number of Changes in Charg Conditions set at P-GW/GGSN = 2. Change Condition takes place. No A Interim is sent. P-GW/GGSN stor SDC. [3] Change Condition 2 takes An ACR Interim i Now Max Numbe Changes in Charg conditions is popu in the PS-Infoma Service-Data-Con (1 for each change condition) are pop in the ACR Interim CCF creates the p record.

ACR Message	Change-Condition Value	CCF Response to Change-Condition Value			CC Level Population		Comments
		Addition of Container	Partial FDR	Final FDR	PS-Information Level	SDC Level	
Stop	Management Intervention	YES	NO	YES	YES	YES	Management intervention will close the PDN session from P-GW/GGSN.
Interim	-	YES	NO	NO	N/A	N/A	This is included here to indicate that an ACR[Interim] due to a timer will contain one more populated SDC/ for a/all flow/s, but Change-Condition AV will NOT be populate

Configuring P-CSCF/S-CSCF Rf Interface Support

To configure P-CSCF/S-CSCF Rf interface support, use the following configuration:

```

configure
context vpn
  aaa group default
    diameter authentication dictionary aaa-custom8
    diameter accounting dictionary aaa-custom2
    diameter accounting endpoint <endpoint_name>
    diameter accounting server <server_name> priority <priority>
    exit
  diameter endpoint <endpoint_name>
    origin realm <realm_name>
    use-proxy
    origin host <host_name> address <ip_address>
    peer <peer_name> address <ip_address>
    exit
  end

```

Notes:

- For information on commands used in the basic configuration for Rf support, refer to the *Command Line Interface Reference*.

Gathering Statistics

This section explains how to gather Rf and related statistics and configuration information.

In the following table, the first column lists what statistics to gather, and the second column lists the action to perform.

Statistics/Information	Action to perform
Complete statistics for Diameter Rf accounting sessions	show diameter aaa-statistics

The following is a sample output of the **show diameter aaa-statistics** command:

```

Authentication Servers Summary
-----
Message Stats :
  Total MA Requests:          0      Total MA Answers:          0
  MAR - Retries:             0      MAA Timeouts:             0
  MAA - Dropped:             0
  Total SA Requests:          0      Total SA Answers:          0
  SAR - Retries:             0      SAA Timeouts:             0
  SAA - Dropped:             0
  Total UA Requests:          0      Total UA Answers:          0
  UAR - Retries:             0      UAA Timeouts:             0
  UAA - Dropped:             0
  Total LI Requests:          0      Total LI Answers:          0
  LIR - Retries:             0      LIA Timeouts:             0
  LIA - Dropped:             0
  Total RT Requests:          0      Total RT Answers:          0
  RTR - Rejected:            0
  Total PP Requests:          0      Total PP Answers:          0
  PPR - Rejected:            0
  Total DE Requests:          0      Total DE Answers:          0
  DEA - Accept:              0      DEA - Reject:             0
  DER - Retries:             0      DEA Timeouts:             0
  DEA - Dropped:             0
  Total AA Requests:          0      Total AA Answers:          0
  AAR - Retries:             0      AAA Timeouts:             0
  AAA - Dropped:             0
  ASR:                       0      ASA:                      0
  RAR:                       0      RAA:                      0
  STR:                       0      STA:                      0
  STR - Retries:             0

Message Error Stats:
  Diameter Protocol Errs:     0      Bad Answers:              0
  Unknown Session Reqs:      0      Bad Requests:             0
  Request Timeouts:          0      Parse Errors:             0
  Request Retries:           0

Session Stats:
  Total Sessions:             0      Freed Sessions:           0
  Session Timeouts:          0      Active Sessions:          0

STR Termination Cause Stats:
  Diameter Logout:           0      Service Not Provided:     0
  Bad Answer:                 0      Administrative:           0
  Link Broken:                 0      Auth Expired:             0
  User Moved:                 0      Session Timeout:          0
  User Request:                0      Lost Carrier              0
  Lost Service:                0      Idle Timeout              0
  NAS Session Timeout:        0      Admin Reset               0
  Admin Reboot:                0      Port Error:               0
  NAS Error:                   0      NAS Request:              0
  NAS Reboot:                  0      Port Unneeded:            0
  Port Preempted:             0      Port Suspended:           0
  Service Unavailable:         0      Callback:                 0
  User Error:                  0      Host Request:              0

Accounting Servers Summary
-----
Message Stats :
  Total AC Requests:          0      Total AC Answers:          0

```

ACR-Start:	0	ACA-Start:	0
ACR-Start Retries :	0	ACA-Start Timeouts:	0
ACR-Interim:	0	ACA-Interim:	0
ACR-Interim Retries :	0	ACA-Interim Timeouts:	0
ACR-Event:	0	ACA-Event:	0
ACR-Stop :	0	ACA-Stop:	0
ACR-Stop Retries :	0	ACA-Stop Timeouts:	0
ACA-Dropped :	0		
AC Message Error Stats:			
Diameter Protocol Errs:	0	Bad Answers:	0
Unknown Session Reqs:	0	Bad Requests:	0
Request Timeouts:	0	Parse Errors:	0
Request Retries:	0		



CHAPTER 50

Routing Behind the Mobile Station on an APN

The routing behind the Mobile Station (MS) feature enables the routing of packets to IPv4 addresses that do not belong to the PDN Session (the MS), but exist behind it. The network address of the destination can be different than the Mobile Station address.

This chapter includes the following topics:

- [Feature Description, on page 925](#)
- [How It Works, on page 925](#)
- [Configuring Routing Behind the Mobile Station, on page 926](#)
- [Monitoring and Troubleshooting the Routing Behind the Mobile Station, on page 930](#)

Feature Description

The Framed-Route attribute provides routing information to be configured for the user on the network access server (NAS). The Framed-Route information is returned to the RADIUS server in the Access-Accept message. Framed-Route can work at a context level or VRF level. VRFs can be on per enterprise and each can have its own set of framed-routes. In such configuration, framed routes will be installed in VRF's dedicated for respective enterprise. Association of Framed-Route with VRF will be done based on subscriber IP pool.

Mobile Router enables a router to create a PDN Session which the GGSN authorizes using RADIUS server. The RADIUS server authenticates this router and includes a Framed-Route attribute in the access-accept response packet. Framed-Route attribute also specifies the subnet routing information to be installed in the GGSN for the "mobile router." If the GGSN receives a packet with a destination address matching the Framed-Route, the packet is forwarded to the mobile router through the associated PDN session.

How It Works

Routing Behind the Mobile Station on an APN

The following rules apply:

- AAA interface of GGSN/P-GW supports receiving "Framed Route AVP" in Radius Access-Accept Message from the Radius Server.
- AAA interface of GGSN/P-GW supports maximum 16 "Framed Route AVP" in Radius Access-Accept Message

- GGSN/P-GW does not accept framed route with destination address as 0.0.0.0 and/or netmask as 0.0.0.0.
- GGSN/P-GW does not accept framed route where gateway address in the route is not matching with the address that would be assigned to Mobile station.
- GGSN/P-GW ignores duplicate framed routes.
- GGSN/P-GW supports controlling enabling/disabling of this feature through CLI in APN Configuration.
- GGSN/P-GW supports controlling number of framed-routes to be installed through this feature.
- GGSN/P-GW supports controlling number of hosts (addresses) supported behind the mobile station per route.
- The routing behind an MS is supported only for IPv4 PDP contexts.
- Packets routed behind the MS share the same 3GPP QoS settings of the MS.

Configuring Routing Behind the Mobile Station

The routing behind the MS feature enables the routing of packets to IPv4 addresses that do not belong to the PDN Session (the MS), but exist behind it. The network address of the destination can be different than the MS address.

Before enabling routing behind the MS, the following requirements must be met:

- The MS must use RADIUS for authentication and authorization.
- The Framed-Route (attribute 22) as defined in Internet Engineering Task Force (IETF) standard RFC 2865, must be configured in the profile of a user and contain at least one route, and up to 16 routes for each MS that is to use the routing behind the MS feature.

When configured, the Framed-Route attribute is automatically downloaded to the GGSN during the RADIUS authentication and authorization phase of the PDN Session creation. If routing behind the MS has not been enabled using the network-behind-mobile command in access-point configuration mode, the GGSN ignores the Framed-Route attribute.

When the MS session is no longer active, the routes are deleted.

- Static routes are not configured. The configuration of the routing behind the mobile station feature (Framed Route, attribute 22) and static routes at the same time is not supported.

Configuration Overview

To enable routing behind a Mobile Station perform the following steps:

-
- Step 1** Create an APN Profile. Refer to [Creating an APN Profile, on page 926](#).
- Step 2** Enable or disable a Network behind Mobile Station for APN. Refer to [Enabling Routing Behind the Mobile Station, on page 927](#).
-

Creating an APN Profile

Use the following example to create an APN profile on the P-GW/SAEGW/S-GW:

```

config
  context context_name
  apn apn_name
end

```

Notes:

- The apn name must be an alphanumeric string from 1 to 64 characters in length.
- Once you have created an APN profile, you will enter the Access Point Profile Configuration Mode.

Enabling Routing Behind the Mobile Station

To enable routing behind an MS, use the following steps command in access-point configuration mode:

```

config
  network-behind-mobile { max-addresses-behind-mobile max_addr |
max-subnets max_subnets }
  { default | no } network-behind-mobile
end

```

Notes:

- **default**

Enables the default settings for this function. It enables NBMS with max-subnets as 10 and max-addresses-behind-mobile as 16,777,214 default values.

- **no**

Disables the network behind mobile station functionality on the APN.

- **max-addresses-behind-mobile** *max_addr*

Configures the maximum number of addresses that are allowed in a single Network/subnet Behind MS.

- **max-subnets** *max_subnets*

Specifies the maximum number of subnets that can be enabled for a call in the APN.

max_subnets must be an integer from 1 through 16.

Default: 10

Verifying the Routing Behind the Mobile Station

To verify the routing behind the mobile station configuration, use the following show commands.

1. Router show ip route vrf vpn_am2
 "*" indicates the Best or Used route. S indicates Stale.

Destination	Nexthop	Protocol	Prec	Cost	Interface
*17.18.19.20/32	10.7.104.2	bgp	20	0	bgp_neighbour
(nhlfe-ix:3)					
*17.18.19.21/32	0.0.0.0	connected	0	0	vpn_am21b1
*40.40.41.0/24	0.0.0.0	connected	0	0	
*41.40.41.0/24	0.0.0.0	connected	0	0	
*42.40.41.0/24	0.0.0.0	connected	0	0	
*43.40.41.0/24	0.0.0.0	connected	0	0	
*44.40.41.0/24	0.0.0.0	connected	0	0	
*45.40.41.0/24	0.0.0.0	connected	0	0	

Verifying the Routing Behind the Mobile Station

```

*46.40.41.0/24      0.0.0.0      connected 0 0
*47.40.41.0/24      0.0.0.0      connected 0 0
*48.40.41.0/24      0.0.0.0      connected 0 0
*49.40.41.0/24      0.0.0.0      connected 0 0
*106.106.0.0/16     0.0.0.0      connected 0 0      pool pool_test_3
Total route count : 13
Unique route count: 13
Connected: 12 BGP: 1

```

2. show subscribers pgw-only full all

```

Username: starent
Subscriber Type : Visitor
Status : Online/Active
State : Connected
Connect Time : Mon Oct 12 12:23:52 2015
Auto Delete : No
Idle time : 00h00m50s
MS TimeZone : n/a Daylight Saving Time: n/a
Access Type: gtp-pdn-type-ipv4 Network Type: IP
Access Tech: eUTRAN pgw-service-name: PGW21
Callid: 0db5d3a3 IMSI: 123456789012345
Protocol Username: starent MSISDN: 9326737733
Interface Type: S5S8GTP Low Access Priority: N/A
Emergency Bearer Type: N/A
IMS-media Bearer: No
S6b Auth Status: N/A
Access Peer Profile: default
Acct-session-id (C1): 141414650F55554B
ThreeGPP2-correlation-id (C2): 17767C4D / 6SKDhW-2
Card/Cpu: 12/0 Sessmgr Instance: 47
Bearer Type: Default Bearer-Id: 5
Bearer State: Active
IP allocation type: local pool
IPv6 allocation type: N/A
IP address: 209.165.200.225
Framed Routes: Framed Routes Source: RADIUS
 40.40.41.0 255.255.255.0 106.106.0.5
 41.40.41.0 255.255.255.0 106.106.0.5
 43.40.41.0 255.255.255.0 106.106.0.5
 44.40.41.0 255.255.255.0 106.106.0.5
 45.40.41.0 255.255.255.0 106.106.0.5
 46.40.41.0 255.255.255.0 106.106.0.5
 47.40.41.0 255.255.255.0 106.106.0.5
 48.40.41.0 255.255.255.0 106.106.0.5
 49.40.41.0 255.255.255.0 106.106.0.5
 42.40.41.0 255.255.255.0 106.106.0.5
ULI:
TAI-ID:
MCC: 214 MNC: 365
TAC: 0x6789
ECGI-ID:
MCC: 214 MNC: 365
ECI: 0x1234567
Accounting mode: None APN Selection Mode: Sent by MS
MEI: 1122334455667788 Serving Nw: MCC=123, MNC=765
charging id: 257250635 charging chars: normal
Source context: EPC2 Destination context: ISP1
S5/S8/S2b/S2a-APN: cisco.com
SGi-APN: cisco.com
APN-OI: n/a
Restoration priority level: n/a
traffic flow template: none
IMS Auth Service : IMSGx
active input ipv4 acl: IPV4ACL active output ipv4 acl: IPV4ACL
active input ipv6 acl: active output ipv6 acl:

```



```

ECS Rulebase: cisco
Bearer QoS:
QCI: 5
ARP: 0x04
PCI: 0 (Enabled)
PL : 1
PVI: 0 (Enabled)
MBR Uplink(bps): 0
GBR Uplink(bps): 0
PCRF Authorized Bearer QoS:
QCI: n/a
ARP: n/a
PCI: n/a
PL: n/a
PVI: n/a
MBR uplink (bps): n/a
GBR uplink (bps): n/a
Downlink APN AMBR: n/a
P-CSCF Address Information:
Primary IPv6 : n/a
Secondary IPv6: n/a
Tertiary IPv6 : n/a
Primary IPv4 : n/a
Secondary IPv4: n/a
Tertiary IPv4 : n/a
Access Point MAC Address: N/A
pgw c-teid: [0x8000002f] 2147483695
sgw c-teid: [0x50010001] 1342242817
ePDG c-teid: N/A
cgw c-teid: N/A
pgw c-addr: 2002::2:101
sgw c-addr: 2002::2:61
ePDG c-addr: N/A
cgw c-addr: N/A
Downlink APN AMBR: 16534000 bps
Mediation context: None
Mediation No Interims: Disabled
input pkts: 0
input bytes: 0
input bytes dropped: 0
input pkts dropped: 0
input pkts dropped due to lorc : 0
0
input bytes dropped due to lorc : 0
in packet dropped suspended state: 0

in bytes dropped suspended state: 0
in packet dropped overcharge protection: 0
protection: 0
in bytes dropped overcharge protection: 0
0
in packet dropped sgw restoration state: 0
state: 0
in bytes dropped sgw restoration state: 0
state: 0
pk rate from user(bps): 0
ave rate from user(bps): 0
sust rate from user(bps): 0
pk rate from user(pps): 0
ave rate from user(pps): 0
sust rate from user(pps): 0
link online/active percent: 65
ipv4 bad hdr: 0
ipv4 fragments sent: 0

MBR Downlink(bps): 0
GBR Downlink(bps): 0

MBR downlink (bps): n/a
GBR downlink (bps): n/a
Uplink APN AMBR: n/a

pgw u-teid: [0x8000002f] 2147483695
sgw u-teid: [0x60010001] 1610678273
ePDG u-teid: N/A
cgw u-teid: N/A
pgw u-addr: 209.165.200.232 2002::2:101
sgw u-addr: 2002::2:61
ePDG u-addr: N/A
cgw u-addr: N/A
Uplink APN AMBR: 16534000 bps
Mediation no early PDUs: Disabled
Mediation Delay PBA: Disabled
output pkts: 0
output bytes: 0
output bytes dropped: 0
output pkts dropped: 0
output pkts dropped due to lorc :

out packet dropped suspended state: 0

out bytes dropped suspended state: 0
out packet dropped overcharge
out bytes dropped overcharge protection:
out packet dropped sgw restoration
out bytes dropped sgw restoration

pk rate to user(bps): 0
ave rate to user(bps): 0
sust rate to user(bps): 0
pk rate to user(pps): 0
ave rate to user(pps): 0
sust rate to user(pps): 0

ipv4 ttl exceeded: 0
ipv4 could not fragment: 0

```

```

    ipv4 input acl drop: 0
    ipv4 bad length trim: 0
    ipv4 input mcast drop: 0
    ipv6 input acl drop: 0
    ipv4 input css down drop: 0
    ipv4 input css down drop: 0
    ipv4 output xoff pkts drop: 0
    ipv6 output xoff pkts drop: 0
    ipv6 input ehrpd-access drop: 0
    input pkts dropped (0 mbr): 0
    ip source violations: 0
    ipv6 egress filtered: 0
    ipv4 proxy-dns redirect: 0
    ipv4 proxy-dns drop: 0
    ipv4 proxy-dns redirect tcp connection: 0
    ipv6 bad hdr: 0
    ip source violations no acct: 0
    ip source violations ignored: 0
    dormancy total: 0
    ipv4 icmp packets dropped: 0
    APN AMBR Input Pkts Drop: 0
    APN AMBR Input Bytes Drop: 0

    ipv4 output acl drop: 0
    ipv4 input bcast drop: 0
    ipv6 output acl drop: 0
    ipv4 output css down drop: 0
    ipv4 output css down drop: 0
    ipv4 output xoff bytes drop: 0
    ipv6 output xoff bytes drop: 0
    ipv6 output ehrpd-access drop: 0
    output pkts dropped (0 mbr): 0
    ipv4 output no-flow drop: 0

    ipv4 proxy-dns pass-thru: 0

    ipv6 bad length trim: 0

    handoff total: 0

    APN AMBR Output Pkts Drop: 0
    APN AMBR Output Bytes Drop: 0

```

Monitoring and Troubleshooting the Routing Behind the Mobile Station

Routing Behind the Mobile Station Show Command(s) and/or Outputs

show apn name <apn_name>

```

...
proxy-mip: Disabled
proxy-mipv6: Disabled
proxy-mip null-username static home address: Disabled
Network Behind Mobile Station: Enabled
Maximum subnets behind Mobile station: 10
Maximum Addresses Behind Mobile Station: 16777214
Tunnel peer load-balancing : random
L3-to-L2 tunnel address-policy no-alloc-validate
tunnel address-policy alloc-validate
NPU QoS Traffic Priority: Derive from packet DSCP

```



CHAPTER 51

Routing Based on Realm Name S6B

- [Summary Data, on page 931](#)
- [Overview of Routing Based on Realm P-GW, on page 932](#)
- [How it Works, on page 932](#)
- [Enabling Realm for S6b Interface, on page 932](#)

Summary Data

Summary Data

Applicable Product(s) or Functional Area	<ul style="list-style-type: none"> • P-GW • SAEGW
Applicable Platform(s)	<ul style="list-style-type: none"> • ASR 5500 • VPC-DI • VPC-SI
Feature Default	Disabled - Configuration Required
Related Changes in This Release	Not applicable
Related Documentation	<ul style="list-style-type: none"> • <i>Command Line Interface Reference</i> • <i>P-GW Administration Guide</i> • <i>SAEGW Administration Guide</i>

Table 85: Revision History

Revision Details	Release
First introduced	21.19

Overview of Routing Based on Realm P-GW

Currently, not all diameter applications have an option to have configurable 'Destination-Realm' name on initial diameter messages going out of P-GW. As a result, DRAs whenever P-GW is connected to diameter application servers through DRA must look inside those messages, make a routing decision to route it to the correct application server and then overwrite the destination-realm received from client node before sending out to the application server node. However, this generates some level of increased processing and load on the DRA.

This feature provides the facility to fill the 'Destination-realm' value from a configurable value to allow DRAs to act in 'transparent' mode thus reducing the load on them. It also allows DRAs to use more sophisticated load balancing mechanisms based on 'Destination-realm'.

Part of this feature was developed for MME (S6a and S13 interfaces). For P-GW, the facility is already present with 'host-select' and 'peer-select' commands on Gx and Gy interfaces but S6b interface does not have any such facility. This feature fills that gap.

How it Works

Under this feature, 'Destination-Realm' AVP in AAR message towards DRA contains the value configured under 'realm' as described in the next section. This allows DRAs to act in transparent mode. 'Destination-Realm' AVP is also set to the configured value in further messages for that session, for example, STR.

Enabling Realm for S6b Interface

Use the following configuration to associate the diameter authentication server with a realm name:

```
configure
  context context_name
    aaa group group_name
      diameter authentication server diameter_host_name priority priority_value
    realm realm_name
  end
```



Note If the 'realm' attribute is configured, then there must be a 'route-entry' with the same 'realm_name'. This is described in the example given below:

Example

```
aaa group s6b
  diameter authentication endpoint s6b
  diameter authentication server dral.dra.mnc123.mcc456.3gppnetwork.org priority 10 realm
xyz.org

...

diameter endpoint s6b
  origin realm abc.com
  use-proxy
```

```
origin host SPRC01.s6b address 10.239.144.69
watchdog-timeout 6
device-watchdog-request max-retries 3
response-timeout 5
cea-timeout 3
reconnect-timeout 30
connection retry-timeout 10
peer dra1.dra.mnc123.mcc456.3gppnetwork.org realm dra.mnc123.mcc456.3gppnetwork.org
address 10.1.1.1
peer dra2.dra.mnc123.mcc456.3gppnetwork.org realm dra.mnc123.mcc456.3gppnetwork.org
address 10.1.1.2
route-entry realm xyz.org peer dra1.dra.mnc123.mcc456.3gppnetwork.org
```



CHAPTER 52

Secondary RAT Usage Report in CDR Records

- [Feature Summary and Revision History, on page 935](#)
- [Feature Description, on page 936](#)
- [Configuring Secondary RAT Usage Report through GTPP, on page 939](#)
- [Monitoring and Troubleshooting, on page 942](#)

Feature Summary and Revision History

Summary Data

Applicable Product(s) or Functional Area	<ul style="list-style-type: none">• P-GW• SAEGW• S-GW
Applicable Platform(s)	<ul style="list-style-type: none">• ASR 5500• VPC-DI
Feature Default	Disabled - Configuration Required
Related Changes in This Release	Not Applicable
Related Documentation	<ul style="list-style-type: none">• <i>Command Line Interface Reference</i>• <i>GTPP Interface Administration and Reference</i>• <i>P-GW Administration Guide</i>• <i>SAEGW Administration Guide</i>• <i>S-GW Administration Guide</i>• <i>Statistics and Counters Reference</i>

Revision History

Revision Details	Release
P-GW and S-GW supports secondary RAT usage reports and CDRs processing through GTPP Group Configuration CLIs.	<ul style="list-style-type: none"> • 21.26 • 21.23.14
P-GW and S-GW supports secondary RAT usage reports and CDRs processing through GTPP Group Configuration CLIs.	21.20.31
First Introduced.	21.22.n7

Feature Description

Reporting issues pertaining to 5G **RANSecondaryRATUsageReport** occur due to lack of:

- Control in identifying whether the **RANSecondaryRATUsageReport** must be processed in CDRs or not. This allows the S-GW, P-GW, and SAEGW to either include these reports in the SGW-CDR or PGW- CDR or to simply ignore them.
- Number of available reports inside a CDR, if the control is active.
- Control in identifying whether Zero-volume reports must make it inside the CDR or not.

This results in billing loss of data. To overcome these reporting issues, you can trigger CLI controls using GTPP group configuration to:

- Allow the S-GW, P-GW, and SAEGW to either include the RANSecondary RAT Usage reports in the SGW-CDR or PGW-CDR or to simply ignore them.
- Identify the number of secondary RAT usage reports available inside the SGW-CDR or the PGW- CDR.



Note This limit must be in accordance with the system capability and ensure to consider the File-Format of the CDRs. If the configured limit exceeds, the system closes the SGW-CDR or PGW-CDR with the appropriate change-condition. For example, **max-change-condition** CDR is reused for further reports.

- Add or ignore Zero-volume reports inside the CDR.
- The CLI **gtp limit-secondary-rat-usage** or hardcoded limit will be removed and the CLI **gtp limit-secondary-rat-usage** is reused to control the number of records within the range 1-100.
- Provides logging when the CDR size reaches the maximum size. Through PGW-CDR counter, you can monitor the number of occurrences when the CDR exceeds its size limit.

Behavior Matrix

The following table explains the new behavior of P-GW and S-GW for this feature.

CLI	P-GW New Behavior	S-GW New Behavior
<p>gtp attribute secondary-rat-usage</p> <p>By default, this CLI command is enabled in gtp group.</p>	P-GW sends secondary RAT usage records in CDR including zero volume records.	S-GW sends secondary RAT usage records in CDR including zero volume records.
<p>[no] gtp attribute secondary-rat-usage</p>	P-GW does not send secondary RAT usage records in CDR.	S-GW does not send secondary RAT usage records in CDR.
<p>gtp suppress-secondary-rat-usage zero-volume</p> <p>By default, this CLI command is disabled in gtp group.</p>	P-GW does not include and send zero volume secondary RAT records in CDR. P-GW sends only secondary RAT records with non-zero volumes.	S-GW does not include and send zero volume secondary RAT records in CDR. S-GW sends only secondary RAT records with non-zero volumes.
<p>[no] gtp suppress-secondary-rat-usage zero-volume</p>	P-GW sends secondary RAT usage records including zero volume records in CDR.	S-GW sends secondary RAT usage records including zero volume records in CDR.
<p>gtp limit-secondary-rat-usage range_1-100. If not configured, the default value is 32. By default, this CLI command is enabled in gtp group.</p> <p>Example: gtp limit-secondary-rat-usage 32</p> <p>Note This CLI is the modification of the existing CLI command gtp limit-secondary-rat-usage with range between 1–100.</p>	<p>P-GW generates CDR immediately when total received secondary RAT records exceeds 32 and reported cause value is <i>maximum change condition</i>.</p> <p>P-GW generates multiple CDRs if total received secondary RAT records are multiples of 32.</p> <p>Example: If P-GW receives 100 RAT records between two triggers, P-GW generates 3 CDRs and keeps the remaining 4 RAT records for the next CDR trigger.</p>	<p>S-GW generates CDR immediately when total received secondary RAT records exceeds 32 and the reported cause value is <i>maximum change condition</i>.</p> <p>S-GW generates multiple CDRs if the total received secondary RAT records are multiples of 32.</p> <p>Example: If S-GW receives 100 RAT records between two triggers, S-GW generates 3 CDRs and keeps the remaining 4 RAT records for the next CDR trigger.</p>
<p>Example: gtp limit-secondary-rat-usage 40</p>	<p>P-GW generates CDR immediately when total received secondary RAT records exceeds 40 and cause value is <i>maximum change condition</i>.</p> <p>P-GW generates multiple CDRs if total received secondary RAT records are multiples of 40.</p> <p>Example: If P-GW receives 100 RAT records between two triggers, it will generate 2 CDRs and will keep remaining 20 RAT records for the next CDR trigger.</p>	<p>If the configured value is greater than 32 and sends 32 secondary RAT records in every CDR, Ignores gtp limit-secondary-rat-usage 40 CLI command.</p>

CLI	P-GW New Behavior	S-GW New Behavior
Example:gtpp limit-secondary-rat-usage 20	<p>P-GW generates CDR immediately when total received secondary RAT records exceed 20 and cause value is <i>maximum change condition</i>.</p> <p>P-GW generates multiple CDRs if total received secondary RAT records are multiples of 20.</p> <p>Example: If P-GW receives 100 RAT records between two triggers, P-GW generates 2 CDRs and will store the remaining 20 RAT records for the next CDR trigger.</p>	<p>S-GW generates CDR immediately when the total received secondary RAT records exceeds 20 and cause value is <i>maximum change condition</i>.</p> <p>S-GW generates multiple CDRs if total received secondary RAT records are in multiples of 20.</p> <p>Example: If S-GW receives 100 RAT records between two triggers, it will generate 5 CDRs.</p>
[no] gtpp limit-secondary-rat-usage	<p>Generates CDR immediately when the total received secondary RAT records exceed 255 and cause value is <i>maximum change condition</i>.</p> <p>Generates multiple CDRs if the total received secondary RAT records are multiples of 255.</p> <p>Example: If 1000 RAT records between two triggers are received, then 3 CDRs are generated. The remaining 235 RAT records are stored for the next CDR trigger.</p>	<p>Ignores the [no] gtpp limit-secondary-rat-usage CLI and sends 32 secondary RAT records in every CDR.</p> <p>Behavior is similar to the gtpp limit-secondary-rat-usage 32 CLI implementation.</p> <p>Counter and debug logs are not required as it will never exceed the CDR size of 64k.</p>
	Service-specific unit limit is sent in the serviceConditionChange file.	Record Closure

Relationship to Other Features

- Sessmgr Restart While Processing Secondary RAT Usage CDR Records in the *P-GW Administration Guide*.
- Secondary RAT Usage IE during GnGp handover, S-GW, and P-GW support of Secondary RAT Data Usage Report in Gz CDRs, see the *5G Non-Standalone* chapter in the *P-GW Administration Guide*.
- P-GW support of Secondary RAT Data Usage Report in Rf CDRs, see the *5G Non-Standalone* chapter in the *P-GW Administration Guide*.

Limitations

This feature has the following limitations:

- S-GW allows a maximum number of 16 secondary RAT records per bearer during session recovery and checkpointing.
- P-GW allows a maximum number of 142 secondary RAT records across all bearers during session recovery and checkpointing.
- Anything beyond these numbers gets lost during session recovery.

Configuring Secondary RAT Usage Report through GTPP

Use the following GTPP configurations to close Secondary RAT Usage CDR records before exceeding a buffer size.

Enabling or Disabling the Secondary RAT Usage Report

Use the following configuration to enable or disable secondary RAT Usage report.

```
configure
context context_name
  gtp group group_name
    gtp attribute secondary-rat-usage
  default gtp attribute secondary-rat-usage
  no gtp attribute secondary-rat-usage
end
```

NOTES:

- **gtp attribute secondary-rat-usage**: Sends an optional attribute Secondary RAT usage records.
- **default gtp attribute secondary-rat-usage**: Sends an optional attribute Secondary RAT usage records by default.
- **no gtp attribute secondary-rat-usage**: Does not send the optional attribute Secondary RAT usage records.

Controlling the Maximum Number of Entries

When the Secondary RAT usage record reaches the maximum configured value within a CDR, the CDR closure cause occurs and uses **maxChangeCond**. The **gtp limit-secondary-RAT-usage** CLI command controls the maximum number of Secondary RAT usage record entries in the P-GW and S-GW CDRs. If the limit is configured with a value more than 32, the partial CDRs get generated with a maximum of 32 for S-GW CDR.



Note The existing behaviour of S-GW has a limit of 32 Secondary RAT Usage records.

The following table explains the behavior of Secondary RAT records and CDR, and the maximum limit.

SI. Number	CDR Type	Configured limit-secondary-rat-usage	Effective Maximum Limit	No. of Secondary RAT records Sent by UE	Behavior of Secondary RAT Records and CDR
1	P-GW	Less than 32 Example: 20	20	35	Partial CDR is generated with 20 secondary RAT records.
					Remaining 15 secondary RAT records sent in the next trigger.
	S-GW	Less than 32 Example: 20	20	35	Partial CDR is generated with 20 Secondary RAT records.
					Remaining 15 Secondary RAT records sent in the next trigger.
2	P-GW	32	32	35	Partial CDR is generated with 32 Secondary RAT records.
					Remaining 3 secondary RAT records sent in the next trigger.
	S-GW	32	32	35	Partial CDR is generated with 32 secondary RAT records.
					Remaining 3 secondary RAT records sent in the next trigger.

SI. Number	CDR Type	Configured limit-secondary-rat-usage	Effective Maximum Limit	No. of Secondary RAT records Sent by UE	Behavior of Secondary RAT Records and CDR
3	P-GW	Greater than 32 Example: 100	100	100	Partial CDR is generated with 100 secondary RAT records.
	S-GW	Greater than 32 Example: 100	32	100	Three partial CDRs are generated with 32 secondary RAT records each. Remaining 4 secondary RAT records sent in the next trigger.
4	P-GW	Not configured	255	1000	Three partial CDRs are generated with 255 secondary RAT records each. Remaining reported Secondary RAT records become a part of CDR in the next trigger.
	S-GW	Not configured	32	1000	No partial CDR is generated. 32 Secondary RAT records become part of the CDR in the next trigger.

Use the following configuration to control the maximum number of entries.

```

configure
context context_name
  gtpv group group_name
    gtpv limit-secondary-rat-usage usage_limit
  default gtpv limit-secondary-rat-usage

```

```
no gtp limit-secondary-rat-usage
end
```

NOTES:

- **gtp limit-secondary-rat-usage *usage_limit***: Enter a maximum number of secondary RAT reports. *usage_limit* must be an integer in the range of 1-100. The recommended value for S-GW CDR is 32. For example, if the limit is set to 10, then the CDR is generated once the configured value is reached.
- **default gtp limit-secondary-rat-usage**: Specifies a default value of 32.
- **no gtp limit-secondary-rat-usage**: Disables the CDR generation with limited number of secondary RAT usage information.

Suppressing Zero-Volume Secondary RAT Usage Report

Use the following configuration to suppress zero-volume Secondary RAT Usage report.

```
configure
context context_name
  gtp group group_name
    gtp suppress-secondary-rat-usage zero-volume
  default gtp suppress-secondary-rat-usage zero-volume
  no gtp suppress-secondary-rat-usage zero-volume
end
```

NOTES:

- **gtp suppress-secondary-rat-usage zero-volume**: Suppresses either Secondary RAT records or zero volume Secondary RAT records.
- **default gtp suppress-secondary-rat-usage zero-volume**: Does not suppress the zero volume secondary RAT usage records.
- **no gtp suppress-secondary-rat-usage zero-volume**: Does not suppress the zero volume Secondary RAT usage records.

Monitoring and Troubleshooting

This section provides information on how to monitor and troubleshoot using show commands available in support of this feature.

Show Commands and Outputs

This section provides information regarding show commands and their outputs for this feature.

show config

The output of this CLI command displays the following parameters.

Field	Description
gtpp attribute secondary-rat-usage	Specify this option to include the Secondary RAT reports field in the CDR.
gtpp suppress-secondary-rat-usage zero-volume	Enables the exclusion of the zero volume Secondary RAT reports in the CDR.
gtpp limit-secondary-rat-usage	Enables limiting the number of Secondary RAT Usage reports in CDR with the configured value.

show config verbose

The output of this CLI command displays the following parameters.

Field	Description
gtpp attribute secondary-rat-usage	Displays the Secondary RAT usage records.
gtpp suppress-secondary-rat-usage zero-volume	Displays only Secondary RAT records that is having non-zero volumes from P-GW and S-GW.
gtpp limit-secondary-rat-usage	If total received Secondary RAT records are multiples of 10, displays multiple CDR generated by P-GW and S-GW. The reported cause value will be the maximum change condition.
no gtpp limit-secondary-rat-usage	Displays Secondary RAT records for unconfigured cause.

show gtpp group

The output of this CLI command displays the following parameters.

Field	Description
Secondary RAT records present	Specifies whether the Secondary RAT record is present or not. The available options are: <ul style="list-style-type: none"> • no • yes
Limit-secondary-rat-usage	Specifies a limit for Secondary RAT usage report.

show gtpp statistics group

The output of this CLI command displays the following parameter.

Field	Description
Total PGW-CDR exceed size limit	Displays the total number of CDRs that exceeded size limit in P-GW.

show gtp statistics group



CHAPTER 53

Separation of 2G, 3G, and 4G Bulkstatistics

This chapter describes the following topics:

- [Feature Summary and Revision History](#), on page 945
- [Feature Description](#), on page 946
- [Configuring RAT types in Stats Profile](#), on page 946
- [Monitoring and Troubleshooting](#), on page 947

Feature Summary and Revision History

Summary Data

Applicable Product(s) or Functional Area	<ul style="list-style-type: none"> • GGSN • P-GW • SAEGW
Applicable Platform(s)	All
Feature Default	Disabled - Configuration Required
Related Changes in This Release	Not Applicable
Related Documentation	<ul style="list-style-type: none"> • <i>Command Line Interface Reference</i> • <i>GGSN Administration Guide</i> • <i>P-GW Administration Guide</i> • <i>SAEGW Administration Guide</i>

Revision History

Revision Details	Release
First introduced.	21.5

Feature Description



Important In this release, this feature is not fully qualified and is available only for testing purpose. For more information, please contact your Cisco Account representative.

This feature separates bulkstats by RAT type (2G, 3G, and 4G). This helps KPI monitoring and reporting per RAT type. Per APN per RAT type statistics is integrated with the existing stats-profile implementation. A new CLI command **rat-type** is added to the **stats-profile** configuration mode to configure the RAT-types in stats-profile.

Configuring RAT types in Stats Profile

A new CLI command **rat-type** has been added to the **stats-profile** configuration mode. This CLI command integrates per APN per RAT type statistics with the existing stats-profile implementation. To gather RAT level statistics, you must configure RAT type under the stats-profile for which RAT level statistics are required. Once that is done, associate stats-profile in APN for which APN per RAT level statistics is required. Only after this association, the stats are collected. Per APN per RAT level statistics are lost if stats-profile association is removed from APN and/or rat type option is removed from stats-profile.

To enable per APN per RAT types statistics collection, execute the following command:

```
configure
  stats-profile <stats_profile_name>
    [no] rat-type { [geran | utran | eutran]* }
  end
```

NOTES:

- **no:** Disables statistics collection based on RAT type.
- **stats-profile:** Configures statistics profile to collect packet drop counters and/or ARP level statistics.
- **rat-type:** Configures collection of RAT level statistics.
- **geran:** Configures collection of statistics for RAT Type GERAN.
- **utran:** Configures collection of statistics for RAT Type UTRAN.
- **eutran:** Configures collection of statistics for RAT Type EUTRAN.

Sample Configuration

Sample configuration to enable stats collection based on rat type:

```
config
  stats-profile stats-info
  rat-type eutran utran
  rat-type utran geran
end
```

Sample configuration to disable stats collection based on rat type:

```
config
  stats-profile stats-info
  no rat-type eutran utran
end
```

Monitoring and Troubleshooting

This section provides information on the show commands available to support the 2G/3G/4G bulkstat separation.

Show Commands and Outputs

This section provides information regarding show commands and their outputs in support of the feature.

show apn statistics all

The output of the above command is modified to display the following new field depending on whether the CLI command is enabled or disabled:

- Data Statistics:
 - RAT Type statistics for uplink and downlink bytes:
 - GERAN
 - Uplnk DataBytes
 - Dlnlk DataBytes
 - UTRAN
 - Uplnk DataBytes
 - Dlnlk DataBytes
 - EUTRAN
 - Uplnk DataBytes
 - Dlnlk DataBytes
 - IP address allocation statistics
 - RAT Type statistics for dynamic address allocation for PDN types IPv4, IPv6, IPv4v6:
 - GERAN Dynamic address allocated:
 - IPv4
 - IPv6
 - IPv4v6
 - UTRAN Dynamic address allocated:

- IPv4
- IPv6
- IPv4v6

show gtpc statistics

The output of the above command is modified to display the following new fields. These fields do not have any dependency on stats-profile configuration. The gtpc stats will increase irrespective of the stats profile configured with rat type.

- Total CPC Req GERAN
- Total CPC Req UTRAN

show stats profile all

The output of the above command is modified to display the following new field depending on whether the CLI is enabled or disabled:

- rat-type geran utran eutran

Bulk Statistics

The following bulk statistics are added in the APN schema to support the 2G, 3G, 4G bulkstats separation feature:

Bulk Statistics	Description
att-pdp-ctxt-geran	Indicates the total number of CPC requests received per APN for a call with a RAT type of GERAN.
att-pdp-ctxt-utran	Indicates the total number of CPC requests received per APN for a call with a RAT type of UTRAN.
dyn-ipv4-success-geran	Indicates the total number of IPv4 contexts requesting dynamically assigned IP addresses that were successfully setup for a GERAN RAT type.
dyn-ipv4-success-utran	Indicates the total number of IPv4 contexts requesting dynamically assigned IP addresses that were successfully setup for a UTRAN RAT type.
dyn-ipv6-success-geran	Indicates the total number of IPv6 contexts requesting dynamically assigned IP addresses that were successfully setup for a GERAN RAT type.
dyn-ipv6-success-utran	Indicates the total number of IPv6 contexts requesting dynamically assigned IP addresses that were successfully setup for a UTRAN RAT type.

Bulk Statistics	Description
dyn-ipv4v6-success-geran	Indicates the total number of IPv4v6 contexts requesting dynamically assigned IP addresses that were successfully setup for a GERAN RAT type.
dyn-ipv4v6-success-utran	Indicates the total number of IPv4v6 contexts requesting dynamically assigned IP addresses that were successfully setup for a UTRAN RAT type.
uplnk-bytes-geran	Indicates the total number of bytes sent from the APN for a GERAN RAT type towards the Internet/PDN on the Gi interface.
dnlnk-bytes-geran	Indicates the total number of bytes received for a GERAN RAT type on the Gi interface for the APN.
uplnk-bytes-utran	Indicates the total number of bytes sent from the APN for a UTRAN RAT type towards the Internet/PDN on the Gi interface.
dnlnk-bytes-utran	Indicates the total number of bytes received for a UTRAN RAT type on the Gi interface for the APN.
uplnk-bytes-eutran	Indicates the total number of bytes sent from the APN for a EUTRAN RAT type towards the Internet/PDN on the Gi interface.
dnlnk-bytes-eutran	Indicates the total number of bytes received for a EUTRAN RAT type on the Gi interface for the APN.



CHAPTER 54

Session Tracing

This chapter provides information on subscriber session trace functionality that allows an operator to trace subscriber activity at various points in the network and at various level of detail. Subscriber session tracing is supported on the following UMTS/EPC GW network elements:

- GGSN
- P-GW
- SAEGW
- S-GW



Important For detailed information for session tracing on the MME, refer to the *MME Administration Guide*.

The product Administration Guides provide examples and procedures for configuration of basic services on the system. It is recommended that you select the configuration example that best meets your service model, and configure the required elements for that model, as described in the respective product Administration Guide, before using the procedures in this chapter.

This chapter includes a feature description, configuration procedures, monitoring commands, and a session tracing file example.

- [Session Tracing Overview, on page 951](#)
- [Configuring Session Trace Functionality, on page 955](#)
- [Monitoring the Session Trace Functionality, on page 965](#)
- [Supported SAEGW Session Trace Configurations, on page 966](#)
- [Session Trace File Example, on page 969](#)

Session Tracing Overview

Session Trace capability enables an operator to trace subscriber activity at various points in the network and at various levels of detail. The trace can be subscriber initiated (that is, signaling based) or management initiated from the CLI (Command Line Interface) and can be propagated throughout the access cloud via the various signaling interfaces available to the UMTS/EPC network element.

Essentially, the Session Trace capability records and forwards all control activity for the monitored subscriber on the monitored interfaces. This is typically all the signaling and authentication/subscriber services messages that flow when a User Equipment (UE) connects to the access network.

All monitored activity is sent to an off-line Trace Collection Entity (TCE) using a standards-based XML format over a File Transfer Protocol (FTP) or secure FTP (sFTP) connection.



Important Session tracing is a resource intensive application in terms of CPU utilization and will affect call rates and data throughput when in use. The use of this feature in a production network should be restricted to minimize the impact on existing services.



Important Only the SFTP option supports for Session Trace function. FTP does not support for the Session Trace function.

As can be seen in the following illustration, of the three Network Elements (NEs) shown, one NE is actively tracing data on one or more interfaces. All data collected is stored as files in an XML format and then transferred to the collection entity using (S)FTP or FTP. Note that IPv4 or IPv6 connectivity is required between the NE and the TCE in order to transfer the files.

Figure 138: Session Tracing Architecture

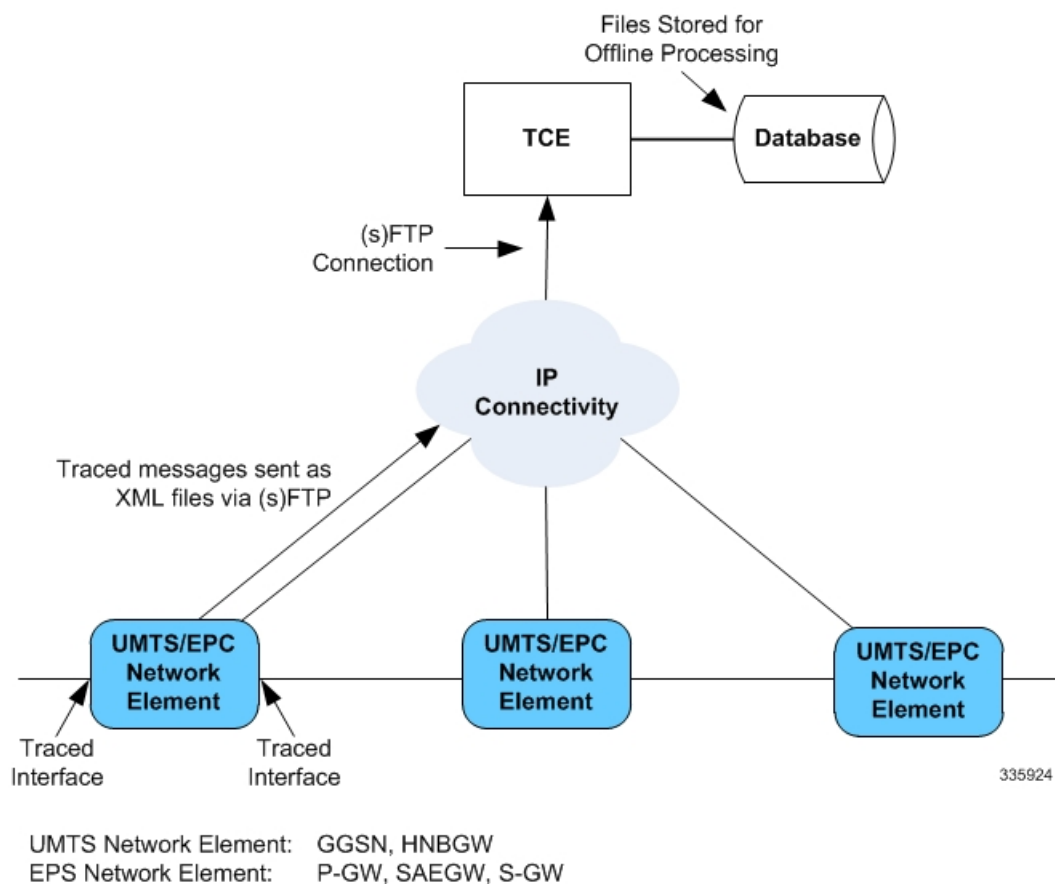

Session Trace Types

There are three types of session trace functions available.

- **Management Trace:** The operator sends an activation request via the CLI directly to the UMTS/EPC network element where the trace is to be initiated. The network element establishes the trace session and waits for a configured trigger event to start actively tracing. When management-initiated trace activations are executed at the network element, they are never propagated to other NEs whether or not it is involved in the actual recording of the call.
- **Random Trace:** Enables or disables the subscriber session trace functionality based on a the random trace on the UMTS/EPC network element. The trace control and configuration parameters are configured directly in the specified network element through the **random trace** CLI command. There is no propagation of trace parameters in random based trace activation. This NE shall not propagate the received data to any other NEs whether or not it is involved in the actual recording of the call. If enabled, the subscriber selection will be based on random logic all instances of session on the specified UMTS/EPC network element.
- **Signaling Trace:** With a signaling based activation, the trace session is indicated to the UMTS/EPC network element across a signaling interface via a trace invocation message. This message can either be piggybacked with an existing bearer setup message (in order to trace all control messages) or by sending a separate trace invocation message (if the user is already active). Signaling based activations are always propagated to neighboring NEs even if the current NE does not participate in the trace (either they not enabled by configuration or not present in the configured trace parameters).



Important

Note that the maximum number of unique International Mobile Subscriber Identification (IMSI) numbers or International Mobile Equipment Identification (IMEI) numbers cannot exceed 32; however, each NE can trace all 32 unique IMSI/IMEIs.



Caution

Session tracing is a resource intensive application in terms of CPU utilization and will affect call rates and data throughput when in use. The use of this feature in a production network should be restricted to minimize the impact on existing services.

Session Trace Activation

Activation of a trace is similar whether it be via the management interface or via a signaling interface. In both cases, a trace session state block is allocated which stores all configuration and state information for the trace session. In addition, an (S)FTP connection to the Trace Collection Entity (TCE) is established if one does not already exist. The NE will store up to 2 MB of XML data on its local disk to allow for the (S)FTP connection to be established and the files to be pushed to or pulled from the TCE.

If the session to be traced is already active, tracing may begin immediately. Otherwise, tracing activity waits until the start trigger occurs (typically when the subscriber/UE under trace initiates a connection). A failure to activate a trace (due to the maximum being exceeded or some other failure reason) results in a notification being sent to the TCE indicating the failure.

Session Trace Deactivation

Deactivation of a Trace Session is similar whether it was management or signaling activated. In either case, a deactivation request is received by the NE that contains valid trace reference results in the de-allocation of the trace session state block and a flushing of any pending trace data. In addition, if this is the last trace session

to a particular TCE, the (S)FTP connection to the TCE is released after the last trace file is successfully transferred to the TCE.

Data Collection

Data collection is done inline by each of the NEs. In order to reduce the overhead on a per-control packet basis, a copy of the entire packet is made and stored into an internal database (DB) of packets.

The local internal path for the trace database is **/hd-raid/trace**.

This storage is done regardless of the trace depth. After xx bytes (or xx messages) have been stored or a configurable number of seconds have elapsed, all cached data is encoded in the standard XML format and written out to a file to be forwarded to/pulled from the TCE. If there is no TCE active, the UMTS/EPC network element will continue to cache data and create trace files as long as there is space available before stopping the trace recording session. Once the connection to the TCE becomes active, all cached data will be sent immediately to the TCE.

Data Forwarding

When a session is activated, the IP address of the TCE is supplied in the session activation request. Upon activation and if the push mode is used, a check is made to see if there is already an (S)FTP connection to the TCE. If so, it is used for all traffic associated with this trace session. If not, an (S)FTP connection is made to the TCE using the supplied IP address. Data is buffered locally and trace files generated until the connection is established. Once the connection is established, all previously created trace files are sent to the TCE. Note that the (S)FTP connection is established to the TCE at session activation regardless of whether or not a trace recording session has been triggered. The (S)FTP connection is maintained until the trace session is deactivated.

Note the following:

- If a default TCE IP Address is supplied when the trace capability is configured, a default (S)FTP connection is made to the remote TCE.
- The TCE can be reachable either via IPv4 or IPv6 addressing. The supplied TCE address indicates the version.
- If the push mode is not used, the files are stored on the local hard drive (**/hd-raid/trace**) and must be pulled off by the TCE using FTP or SFTP.

Supported Standards

Support for the following standards and requests for comments (RFCs) have been added for the Session Trace feature:

- 3GPP TS 32.421 V8.5.0 (2009-06): 3rd Generation Partnership Project; Technical Specification Group Services and System Aspects; Telecommunication management; Subscriber and equipment trace: Trace concepts and requirements (Release 8)
- 3GPP TS 32.422 V8.6.0 (2009-09): 3rd Generation Partnership Project; Technical Specification Group Services and System Aspects; Telecommunication management; Subscriber and equipment trace; Trace control and configuration management (Release 8)
- 3GPP TS 32.423 V8.2.0 (2009-09): 3rd Generation Partnership Project; Technical Specification Group Services and System Aspects; Telecommunication management; Subscriber and equipment trace: Trace data definition and management (Release 8)

Configuring Session Trace Functionality

Configuring Session Trace on the UMTS/EPC network element consists of the following:

1. [Enabling Session Tracing, on page 955](#)
2. [Configuring a Session Trace Template for the Management Trace Function, on page 956](#)
3. [Configuring a Management Session Trace, on page 960](#)
4. [Configuring a Signaling Session Trace, on page 961](#)
5. [Configuring a Random Trace, on page 962](#)

The trace files can be stored locally, or pushed to a Trace Collection Entity (TCE) specified in the various trace commands.



Important Not all combinations of Session Trace configuration types are allowed on the SAEGW. For details on the supported session trace configuration types, refer to [Supported SAEGW Session Trace Configurations, on page 966](#) in this document.

Enabling Session Tracing

Session Tracing functionality must first be enabled before a specific management, random, or signaling session trace can be configured.

The following commands enable or disable the subscriber session trace functionality based on a specified subscriber device or ID on one or all instances of a session on a specified UMTS/EPC network element.

Use the following example to enable session tracing on the UMTS/EPC network element:

```
config
  session trace network-element { all | ggsn | hnbgw | mme | pgw | saegw
  | sgw } [ file-type <a-type | b-type> ] tce-mode none | push transport
  ftp | sftp username username encrypted password password path directory_path
  collection timer ctimer_value
  end
```

Notes:

- **session trace network-element** : Enables Session Tracing functionality on the specified network element. To enable session tracing for all supported network elements, enter **all**.
- **file-type { a-type | b-type }**: Specifies which type of XML file is generated by the session trace. Options include an A-type file and B-type file. When B-type XML files are used, multiple trace recording session elements will be encoded in a single XML file. Note that different trace recording sessions may be associated with different TCEs, according to the TCE IP address specified during activation. As expected, each Type-B XML file will contain traceRecSession elements that pertain only to the same target TCE. There will be different XML Type-B files created for different TCEs and they will be placed in different tce_x directories for transmission to the target TCEs. The default is **a-type**.
- **tce-mode** : Specifies that trace files are stored locally and must be pulled by the TCE (**none**) or trace files are pushed to the TCE (**push**). The default is **none**.
- **transport** : Specifies the method by which the trace files are pushed to the TCE (either **ftp** or **sftp**.) The default is **sftp**.

- **username**: Must be specified if the **tce-mode** is **push**.
- **password**: Must be specified if the **tce-mode** is **push**.
- **encrypted**: Specifies that the password used to push files to the TCE server will be encrypted.
- **password**: Specifies the password to use to push files to the TCE server. The user name can be from 1 to 31 alphanumeric characters.
- **collection-timer**: Specifies the amount of time, in seconds, to wait from initial activation/data collection before data is reported to TCE. The default is 10 seconds.
- **retry-timer**: Specifies the amount of time, in seconds, to wait before retrying a file transfer if the previous transfer failed. The default is 60 seconds.

Example:

```
session trace network-element saegw tce-mode push transport sftp path /SessionTrace username
root encrypted password 5c4a38dc2ff61f72 collection-timer 5
```

Verifying that Session Tracing is Enabled

Use the following example to verify that session tracing functionality is enabled on the UMTS/EPC network element:

```
show session trace statistics
```

The output indicates for which NEs session tracing is enabled, and also indicates the configured trace type, where applicable. For example:

```
Network element status:
  MME:      Enabled      Cell-Trace: Disabled
  S-GW:     Enabled
SAEGW Enabled
  PGW:      Trace-Type: None
  SGW:      Trace-Type: None
```

Disabling Session Trace Functionality

Use the following example to disable session tracing functionality:

```
config
  no session trace network-element { all | ggsn | hnbgw | mme | pgw
  | saegw | sgw }
end
```

Configuring a Session Trace Template for the Management Trace Function

Operators must create a template for a management trace in Global Configuration Mode. Management traces executed in Exec mode will use the template. Once created, the template can be associated with different subscribers to trace the interfaces configured in the template.

Note that to activate subscriber session traces for specific IMSI/IMEI, the operator will use the Exec mode **session trace subscriber** command specifying a pre-configured template and the IMSI/IMEI, trace reference, and TCE address.

Use the following example to configure a template for use with the **session trace subscriber** command:

```
config
  template-session-trace network-element { ggsn | hnbgw | mme | pgw |
  saegw | sgw } template-name template_name
```

Once this command is entered, the user is placed in *Session Trace Template Configuration Mode*. In this mode, the operator selects the interfaces to be traced for the selected network element.



Important The options available in *Session Trace Template Configuration Mode* are dependent on the network element selected in the previous command.

For the **GGSN**, **MME**, **P-GW** and **S-GW**, enter the following command in *Session Trace Template Configuration Mode*:

```
interface interface_name
end
```

For the **SAEGW**, enter the following command in *Session Trace Template Configuration Mode*:

```
{ func-pgw | func-sgw } interface interface_name
end
```

- Notes: The available UMTS/EPC network elements provide various interface options for the session trace template.

GGSN

Available **ggsn** interfaces include:

- **all**: Specifies that all available GGSN interfaces are to be traced.
- **gi**: Specifies that the interface where the trace will be performed is the Gi interface between the GGSN and RADIUS server.
- **gmb**: Specifies that the interface where the trace will be performed is the Gmb interface between the GGSN and BM-SC.
- **gn**: Specifies that the interface where the trace will be performed is the Gn interface between the GGSN and the SGSN.
- **gx**: Specifies that the interface where the trace will be performed is the Gx interface between the GGSN and PCRF.
- **gy**: Specifies that the interface where the trace will be performed is the Gx interface between the GGSN and PCRF.

HNBGW

Available **hnbgw** interfaces are:

- **all**: Specifies that all **hnbgw** interfaces are to be traced.
- **iucs**: Specifies that the interface where the trace will be performed is the iucs interface between the HNB-GW and the Mobile Switching Center (3G MSC) in a 3G UMTS Femtocell Access Network.
- **iups**: Specifies that the interface where the trace will be performed is the iups interface between the HNB-GW and the SGSN.

MME

Available **mme** interfaces include:

- **all**: Specifies that all MME interfaces are to be traced.
- **s10**: Specifies that the interface where the trace will be performed is the S10 interface between the MME and another MME.
- **s11**: Specifies that the interface where the trace will be performed is the S11 interface between the MME and the S-GW.

- **s13**: Specifies that the interface where the trace will be performed is the S13 interface between the MME and the EIR.
- **s1mme**: Specifies that the interface where the trace will be performed is the S1-MME interface between the MME and the eNodeB.
- **s3**: Specifies that the interface where the trace will be performed is the S3 interface between the MME and an SGSN.
- **s6a**: Specifies that the interface where the trace will be performed is the S6a interface between the MME and the HSS.

P-GW

Available **pgw** interfaces are:

- **all**: Specifies that all available P-GW interfaces are to be traced.
- **gx**: Specifies that the interface where the trace will be performed is the Gx interface between the P-GW and the PCRF.
- **gy**: Specifies that the interface where the trace will be performed is the Gy interface between the P-GW and OCS.
- **s2a**: Specifies that the interface where the trace will be performed is the S2a interface between the P-GW and the HSGW.
- **s2b**: Specifies that the interface where the trace will be performed is the S2b interface between the P-GW and an ePDG.
- **s2c**: Specifies that the interface where the trace will be performed is the S2c interface between the P-GW and a trusted, non-3GPP access device.
- **s5**: Specifies that the interface where the trace will be performed is the S5 interface between an S-GW and P-GW located within the same administrative domain (non-roaming).
- **s6b**: Specifies that the interface where the trace will be performed is the S6b interface between the P-GW and the 3GPP AAA server.
- **s8**: Specifies that the interface where the trace will be performed is the S8 interface -- an inter-PLMN reference point between the S-GW and the P-GW used during roaming scenarios.
- **sgi**: Specifies that the interface where the trace will be performed is the SGi interface between the P-GW and the PDN.

SAEGW

The interfaces that can be traced on the SAEGW are broken down by the interfaces available on a P-GW configured under an SAEGW (**func-pgw**), and the interfaces available on a S-GW configured under an SAEGW (**func-sgw**).

- Available **func-pgw interface** options are:
 - **all**: Specifies that all available **func-pgw** interfaces are to be traced.
 - **gx**: Specifies that the interface where the trace will be performed is the Gx interface between the P-GW and the PCRF.
 - **gy**: Specifies that the interface where the trace will be performed is the GTPP based online charging interface between P-GW and online charging system.
 - **s2a**: Specifies that the interface where the trace will be performed is the S2a interface between the PGW and the HSGW.
 - **s2b**: Specifies that the interface where the trace will be performed is the S2b interface between the PGW and an ePDG.
 - **s2c**: Specifies that the interface where the trace will be performed is the S2c interface between the PGW and a trusted, non-3GPP access device.

- **s5**: Specifies that the interface where the trace will be performed is the S5 interface between the P-GW and the S-GW.
 - **s6b**: Specifies that the interface where the trace will be performed is the S6b interface between the PGW and the 3GPP AAA server.
 - **s8**: Specifies that the interface where the trace will be performed is the S8b interface between the PGW and the S-GW.
 - **sgi**: Specifies that the interface where the trace will be performed is the SGi interface between the PGW and the PDN.
- Available **func-sgw interface** options are:
 - **all**: Specifies that all available **func-sgw** interfaces are to be traced.
 - **gxc**: Specifies that the interface where the trace will be performed is the Gx interface between the P-GW and the PCRF.
 - **s11**: Specifies that the interface where the trace will be performed is the S11 interface between the MME and the S-GW.
 - **s4**: Specifies that the interface where the trace will be performed is the S4 interface between the S-GW and an SGSN.
 - **s5**: Specifies that the interface where the trace will be performed is the S5 interface between the S-GW and the P-GW.
 - **s8**: Specifies that the interface where the trace will be performed is the S8b interface between the S-GW and the P-GW.

S-GW

The available **sgw** interfaces are:

- **all**: Specifies that all available S-GW interfaces are to be traced.
- **gxc**: Specifies that the interface where the trace will be performed is the Gxc interface between the S-GW and the PCRF.
- **s11**: Specifies that the interface where the trace will be performed is the S11 interface between the S-GW and the MME.
- **s4**: Specifies that the interface where the trace will be performed is the S4 interface between the S-GW and an SGSN.
- **s5**: Specifies that the interface where the trace will be performed is the S5 interface between the S-GW and the P-GW.
- **s8**: Specifies that the interface where the trace will be performed is the S8 interface between the S-GW and the P-GW.

Verifying the Session Trace Template Configuration

To verify the session trace configuration, enter the following command in Exec Mode.

```
show session trace template network-element { ggsn | hnbgw | mme | pgw |
saegw | sgw } all
```

The output provides the template name, the NE type, and all interfaces configured for tracing.

Disabling the Session Trace Template Configuration

Use the following example to disable the session trace template configuration:

```
no template-session-trace network-element { ggsn | hnbgw | mme | pgw |
saegw | sgw }
```

Disabling the Session Trace Template Configuration per Network Element and Subscriber

To disable the session trace template per network element and subscriber:

```
no session trace subscriber network-element { ggsn | hnbgw | mme | pgw |
saegw | sgw } template-name template_name { imsi id | imei id } trace-ref
trace_ref_value collection-entity ip_address
```

Configuring a Management Session Trace

Session tracing functionality must be enabled before a management trace can be configured. Refer to [Enabling Session Tracing, on page 955](#) for the procedure.

To configure a management session trace on the UMTS/EPC network element from Exec Mode:

```
session trace subscriber network-element { ggsn | hnbgw | mme | pgw |
saegw | sgw } template-name template_name { imei id | imsi id } { all |
interface } } trace-ref id collection-entity ip_address
```

Notes:

- **template-name:** Specifies the name of the session trace template to use for this session trace. Session trace templates are configured in *Global Configuration Mode* using the **template-session-trace** command. Management traces executed in Exec mode will use the specified template.
- **imsi id:** Specifies the International Mobile Subscriber Identification Number for the subscriber.
- **imei id:** Specifies the International Mobile Equipment Identification number for the subscriber.
- **trace-ref:** Specifies the Trace Reference for this subscriber management trace. It must be composed of the Mobile Country Code (MCC) + the Mobile Network Code (MNC) + a 3 byte octet string Trace ID. Example: 31001212349.
- **collection-entity:** Specifies the IP address of the Trace Collection Entity (TCE) to which the trace file generated will be sent. The IP address must be in IPv4 format.

Example:

The following is a complete example showing the configuration of a subscriber management trace for all S-GW and P-GW interfaces. It consists of enabling session tracing on the SAEGW, creating the session trace template for all S-GW and P-GW interfaces, and then executing the subscriber management trace for a specific IMSI using the template.

```
config
  session trace network-element saegw
end
config
  template-session-trace network-element saegw template-name saegw_all
  func-pgw interface all
  func-sgw interface all
end
session trace subscriber network-element saegw template-name saegw_all imsi
123456789012345 trace-ref 123456789012 collection-entity 209.165.200.225
```

Verifying the Management Trace Configuration

To verify that the management trace configuration for the subscriber is enabled, enter the **show session trace statistics** command from Exec Mode. Verify that the correct NE(s) show their Network element status as **Enabled**. For example:

```
SAEGW Enabled
      PGW:                      Trace-Type: M
      SGW:                      Trace-Type: M
```

Use the following example to verify that specific parameters have been activated for the subscriber management trace:

```
show session trace subscriber network-element { ggsn | hnbgw | mme | pgw
| saegw | sgw } trace-ref trace_ref_value
```

The output fields show the NE Type and the Trace Type configured for each network element. Below is sample output for an SAEGW management trace configuration:

```
NE Type: SAEGW
      PGW:                      Trace-Type:      M
      SGW:                      Trace-Type:      M
.....
Traced Interfaces:
PGW:
    <P-GW interfaces configured for the trace.>
SGW:
    <S-GW interfaces configured for the trace.>
```

Disabling the Management Trace Configuration

To disable the management trace configuration from Exec Mode:

```
no session trace subscriber network element { ggsn | hnbgw | mme | pgw |
saegw | sgw } trace ref trace_ref_value
```

Configuring a Signaling Session Trace

Session trace functionality must be enabled before a signaling session trace can be configured. Refer to [Enabling Session Tracing, on page 955](#) for the procedure.

To configure a signaling session trace:

```
session trace signaling network-element { ggsn | hnbgw | mme | pgw | saegw
[ func-pgw | func-sgw ] | sgw }
```

Notes:

- **func-pgw**: Enables tracing of the P-GW signaling under the SAEGW
- **func-sgw**: Enables tracing of the S-GW signaling under the SAEGW
- If neither **func-sgw** or **func-pgw** is specified, then the signaling trace will be performed for all P-GW and S-GW interfaces of the SAEGW.
- **collection-entity**: Specifies the IPv4 or IPv6 address of the Trace Collection Entity (TCE) to which the trace files are sent.

Example:

This example configures a signaling session trace for all S-GW and P-GW interfaces under an SAEGW:

```
session trace signaling network-element saegw
```

Verifying the Signaling Session Trace Configuration

To verify the signaling session trace configuration:

```
show session trace statistics
```

Look for the following fields to verify the signaling trace configuration. For example:

```
Network element status:
.....
SAEGW Enabled
      PGW:                               Trace-Type: S
      SGW:                               Trace-Type: S
```

Disabling the Signaling Session Trace

To deactivate signaling trace on the SAEGW:

```
no session trace signaling network-element { ggsn | hnbgw | mme | pgw |
saegw [ func-pgw | func-sgw ] | sgw }
```

Configuring a Random Trace

Session trace functionality first must be enabled on the UMTS/EPC network element before a random trace can be configured. Refer to [Enabling Session Tracing, on page 955](#) in this chapter for the procedure.

The following command enables or disables the subscriber session trace functionality based on a random trace on the UMTS/EPC network element. If enabled, the subscriber selection will be based on random logic for all instances of session on a specified network element.

To configure a random session trace:

```
session trace random range network-element { ggsn | hnbgw | pgw | saegw |
sgw [ func-pgw | func-sgw ] } interface [ all | interface }
collection-entity ipv4_address
```

Notes:

- **session trace random range**: Enables a random trace for a specified number of subscribers. Valid entries are from 1 to 1000 subscribers.
- **{ ggsn | hnbgw | pgw | saegw | sgw [func-pgw | func-sgw] }**: Specifies that the random trace is enabled for the selected network element.
- **func-pgw**: Enables random tracing of the P-GW interfaces under the SAEGW.
- **func-sgw**: Enables random tracing of the S-GW interfaces under the SAEGW.
- If neither **func-pgw** or **func-sgw** are specified, random tracing will occur for both the P-GW and S-GW.
- **interface**: Specifies the network interfaces for the random trace. Interfaces available depend on the network element type selected.

GGSN

Available **ggsn** interfaces are:

- **all**: Specifies that all available GGSN interfaces are to be traced.
- **gi**: Specifies that the interface where the trace will be performed is the Gi interface between the GGSN and RADIUS server.
- **gmb**: Specifies that the interface where the trace will be performed is the Gmb interface between the GGSN and BM-SC.

- **gn**: Specifies that the interface where the trace will be performed is the Gn interface between the GGSN and the SGSN.
- **gx**: Specifies that the interface where the trace will be performed is the Gx interface between the GGSN and PCRF.
- **gy**: Specifies that the interface where the trace will be performed is the Gx interface between the GGSN and PCRF.

HNBGW

Available **hnbgw** interfaces are:

- **all**: Specifies that all **hnbgw** interfaces are to be traced.
- **iucs**: Specifies that the interface where the trace will be performed is the **iucs** interface between the HNB-GW and the Mobile Switching Center (3G MSC) in a 3G UMTS Femtocell Access Network.
- **iups**: Specifies that the interface where the trace will be performed is the **iups** interface between the HNB-GW and the SGSN.

P-GW

Available P-GW interfaces are:

- **all**: Specifies that all interfaces are to be traced.
- **gx**: Specifies that the interface where the trace will be performed is the Gx interface between the P-GW and the PCRF.
- **gy**: Specifies that the interface where the trace will be performed is the Gy interface between the P-GW and OCS.
- **s2a**: Specifies that the interface where the trace will be performed is the S2a interface between the P-GW and the HSGW.
- **s2b**: Specifies that the interface where the trace will be performed is the S2b interface between the P-GW and an ePDG.
- **s2c**: Specifies that the interface where the trace will be performed is the S2c interface between the P-GW and a trusted, non-3GPP access device.
- **s5**: Specifies that the interface where the trace will be performed is the S5 interface between an S-GW and P-GW located within the same administrative domain (non-roaming).
- **s6b**: Specifies that the interface where the trace will be performed is the S6b interface between the P-GW and the 3GPP AAA server.
- **s8**: Specifies that the interface where the trace will be performed is the S8 interface -- an inter-PLMN reference point between the S-GW and the P-GW used during roaming scenarios.
- **sgi**: Specifies that the interface where the trace will be performed is the SGi interface between the P-GW and the PDN.

SAEGW

The interfaces that can be traced on the SAEGW are broken down by the interfaces available on a P-GW configured under an SAEGW (**func-pgw**), and the interfaces available on a S-GW configured under an SAEGW (**func-sgw**).

Available SAEGW **func-pgw interface** options are:

- **all**: Specifies that all **func-pgw** interfaces configured under an SAEGW are to be traced.
- **gx**: Specifies that the interface where the trace will be performed is the Gx interface between the P-GW and the PCRF.
- **s2a**: Specifies that the interface where the trace will be performed is the S2a interface between the PGW and the HSGW.

- **s2b**: Specifies that the interface where the trace will be performed is the S2b interface between the PGW and an ePDG.
- **s2c**: Specifies that the interface where the trace will be performed is the S2c interface between the PGW and a trusted, non-3GPP access device.
- **s5**: Specifies that the interface where the trace will be performed is the S5 interface between the P-GW and the S-GW.
- **s6b**: Specifies that the interface where the trace will be performed is the S6b interface between the PGW and the 3GPP AAA server.
- **s8**: Specifies that the interface where the trace will be performed is the S8b interface between the PGW and the S-GW.
- **sgi**: Specifies that the interface where the trace will be performed is the SGi interface between the PGW and the PDN.
- **gy**: Specifies that the interface where the trace will be performed is the GTPP based online charging interface between P-GW and online charging system.

Available SAEGW **func-sgw** interfaces are:

- **all**: Specifies that all available **func-sgw** interfaces under an SAEGW are to be traced.
- **gxc**: Specifies that the interface where the trace will be performed is the Gx interface between the P-GW and the PCRF.
- **s11**: Specifies that the interface where the trace will be performed is the S11 interface between the MME and the S-GW.
- **s4**: Specifies that the interface where the trace will be performed is the S4 interface between the S-GW and an SGSN.
- **s5**: Specifies that the interface where the trace will be performed is the S5 interface between the S-GW and the P-GW.
- **s8**: Specifies that the interface where the trace will be performed is the S8b interface between the S-GW and the P-GW.

S-GW: Available **sgw** interfaces are:

- **all**: Specifies that all interfaces are to be traced.
- **gxc**: Specifies that the interface where the trace will be performed is the Gxc interface between the S-GW and the PCRF.
- **s11**: Specifies that the interface where the trace will be performed is the S11 interface between the S-GW and the MME.
- **s4**: Specifies that the interface where the trace will be performed is the S4 interface between the S-GW and an SGSN.
- **s5**: Specifies that the interface where the trace will be performed is the S5 interface between the S-GW and the P-GW.
- **s8**: Specifies that the interface where the trace will be performed is the S8 interface between the S-GW and the P-GW.
- **collection-entity** specifies the IPv4 address of the Trace Collection Entity (TCE)

Example:

To enable random tracing on a range of 40 SAEGW subscribers on all S-GW interfaces and the s5 interface of the P-GW in the SAEGW, enter the following sample command:

```
session trace random 40 network-element saegw func-pgw interface s5 func-sgw
interface all collection-entity 209.165.200.225
```

Verifying the Random Trace Configuration

To verify the random session trace configuration:

```
show session trace statistics
```

Look for the fields that verify that Random Session Trace has been enabled for the network element. For example:

```
Network element status:
...
SAEGW Enabled
      PGW:                               Trace-Type: R
      SGW:                               Trace-Type: R Configured-Random: 40
```

Disabling the Random Trace for a Specific Network Element

To disable random session tracing for a specific network element:

```
no session trace random network-element { ggsn | hnbgw | pgw | saegw |
sgw [ func-pgw | func-sgw ] }
```

Monitoring the Session Trace Functionality

This section provides information on commands you can use to monitor the session trace functionality

show session trace statistics

This command provides high-level statistics on the current use of the session trace functionality, including:

- Number of current trace sessions
- Number of total trace sessions
- Total sessions activated
- Number of activation failures
- Number of sessions triggered
- Total messages traced
- Number of current TCE connections
- Total number of TCE connections
- Total number of files uploaded to all TCEs

show session trace subscriber network-element trace-ref

This command shows detailed information about a specific trace, based on the trace-ref value of the session and network element type. It includes activation time, IMSI, start time, number of trace messages, and total number of files created. It also lists the interfaces that this session trace is configured to trace.

show session trace trace-summary

This command provides the trace-ref value of all session traces, broken down by network element type.

show session trace tce-summary

This command provides the IP address and index information for all configured TCEs.

show session trace tce-address

This command provides detailed information about a specific TCE, including IP address, start time, and total number of files uploaded.

Supported SAEGW Session Trace Configurations

Different tracing configurations are supported on the SAEGW. The different combinations of session tracing types depend on Call Type, Trace Type, and whether the operator would like to configure a Func-SGW and/or a Func-PGW trace.

Note the following:

- M = Management
- R = Random
- S = Signaling

Table 86: Supported Session Trace Configurations on the SAEGW

Func-S-GW Trace Config	Func-P-GW Trace Config	Call Type	S-GW Trace?	P-GW Trace?	Output	Comments
M	M	Collapsed	Yes	Yes	1 SAEGW trace file generated	When M traces are enabled for Func-SGW, Func-PGW and call type Collapsed both S-GW control messages (gtpv2) and P-GW control messages shall be traced in 1 SAEGW trace file.
R	R	Collapsed	Yes	Yes	1 SAEGW trace file generated	
S	S	Collapsed	Yes	Yes	1 SAEGW trace file generated	

Func-S-GW Trace Config	Func-P-GW Trace Config	Call Type	S-GW Trace?	P-GW Trace?	Output	Comments
M+S	M+S	Collapsed	Yes	Yes	2 SAEGW trace files generated	When M+S trace is enabled for Func-S-GW, Func-P-GW and Call Type collapsed trace, S-GW control messages (gtpv2) and P-GW control messages shall be traced in 2 SAEGW trace files. One file due to Management and the other due to Signaling. Both files have the same contents.
M+R	M+R	Collapsed	Yes	Yes	1 SAEGW trace file generated	
S	R	Collapsed	No	No	None	Not a valid trace configuration
R	S	Collapsed	No	No	None	Not a valid trace configuration
M	R	Collapsed	Yes	No	1 SAEGW trace file generated	
R	M	Collapsed	No	Yes	1 SAEGW trace file generated	
M	S	Collapsed	No	Yes	1 SAEGW trace file generated	
S	M	Collapsed	Yes	No	1 SAEGW trace file generated	
M+S	M	Collapsed	Yes	No	2 SAEGW trace files generated	P-GW Trace is generated
M	M+S	Collapsed	No	Yes	2 SAEGW trace files generated, but S-GW trace not generated	S-GW Trace is generated
M+S	S	Collapsed	Yes	Yes	2 SAEGW trace files generated	
S	M+S	Collapsed	Yes	Yes	2 SAEGW trace files generated	

Func-S-GW Trace Config	Func-P-GW Trace Config	Call Type	S-GW Trace?	P-GW Trace?	Output	Comments
M+R	M	Collapsed	Yes	Yes	1 SAEGW trace file generated	
M	M+R	Collapsed	Yes	Yes	1 SAEGW trace file generated	
M+R	R	Collapsed	Yes	No	1 SAEGW trace file generated	
R	M+R	Collapsed	No	Yes	1 SAEGW trace file generated	
M	n/a	Pure S	Yes	No	1 SAEGW trace file generated	Config for func-P-C is not applicable for Pure S calls
S	n/a	Pure S	Yes	No	1 SAEGW trace file generated	
R	n/a	Pure S	Yes	No	1 SAEGW trace file generated	
M+S	n/a	Pure S	Yes	No	2 SAEGW trace files generated	
M+R	n/a	Pure S	Yes	No	1 SAEGW trace file generated	
R+S	n/a	Pure S	No	No	None	Not a valid trace configuration.
n/a	M	Pure P	No	Yes	1 SAEGW trace file generated	
n/a	S	Pure P	No	Yes	1 SAEGW trace file generated	
n/a	R	Pure P	No	Yes	1 SAEGW trace file generated	
n/a	M+S	Pure P	No	Yes	2 SAEGW trace file generated	
n/a	M+R	Pure P	No	Yes	1 SAEGW trace file generated	
n/a	R+S	Pure P	No	Yes	None	Not a valid trace configuration

Session Trace File Example

This section provides an example of a signaling trace file.

Figure 139: Signaling Trace File Example (1 of 3)

```

<<<<OUTBOUND 10:04:53:997 Eventid:141005(3)
[MME-S11]GTPv2C Tx PDU, from 1.20.20.13:30016 to 1.20.20.3:2123 (62)
TEID: 0x000004D3, Message type: EGTP_TRACE_SESSION_ACTIVATION (0x47)
Sequence Number: 0x000401 (1025)
GTP HEADER
    Version number: 2
    TEID flag: Present
    Piggybacking flag: Not present
    Message Length: 0x003A (58)

INFORMATION ELEMENTS
    IMSI:
        Type: 1 Length: 8 Inst: 0
        Value: 123456789012345
        Hex: 0100 0800 2143 6587 0921 43F5

    Trace Info:
        Type: 96 Length: 34 Inst: 0
        Value:
            MCC: 123
            MNC: 456
            Trace Id: 03039

    Triggering Event: 1/0: Event shall be traced / not traced.
    MSC Server:
        SS: 0
        HANDOVERS: 0
        LU/IMSI ATT/DET: 0
        MO & MT SMS: 0
        MO & MT CALLS: 0

    MGW:
        CONTEXT: 0

    SGSN:
        MBMS CONTEXT: 0
        RAU/GPRS ATT/DET: 0
        MO & MT SMS: 0
        PDP CONTEXT: 0

    GGSN:
        MBMS CONTEXT: 0
        PDP CONTEXT: 0

    MME:
        HANDOVERS: 1
        BEARER ACT/MOD/DEL: 1
        UE INIT PDN DISC: 1
        INIT ATT/TAU/DET: 1
        SERVICE REQUEST: 1
        UE INIT PDN CON REQ: 1
  
```

335925

Figure 140: Signaling Trace File Example (2 of 3)

```

PGW:
    BEARER ACT/MOD/DEL: 1
    PDN CONN TERMINATE: 1
    PDN CONN CREATE: 1

SGW:
    BEARER ACT/MOD/DEL: 0
    PDN CONN TERMINATE: 0
    PDN CONN CREATE: 0

List of NE Types: 1/0: Trace Session activated/ not activated.
SGW: 0
MME: 1
BMSC: 0
RNC: 0
GGSN: 0
SGSN: 0
MGW: 0
MSC-S: 0
ENODEB: 1
PDN-GW: 1

Trace Depth:
Value: 5 (MAXIMUM w/o Vendor Specific Extension)

List of Interfaces: 1/0: Interface will be traced/ not traced.
MSC Server:
    CAP: 0
    MAP-F: 0
    MAP-E: 0
    MAP-B: 0
    MAP-G: 0
    MC: 0
    IU: 0
    A: 0
    MAP-C: 0
    MAP-D: 0

MGW:
    IU-UP: 0
    Nb-UP: 0
    MC: 0

SGSN:
    GE: 0
    GS: 0
    MAP-GF: 0
    MAP-GD: 0
    MAP-GR: 0
    GN: 0
    IU: 0
    GB: 0

GGSN:
    GMB: 0
    GI: 0
    GN: 0

```

335926

Figure 141: Signaling Trace File Example (3 of 3)

```
RNC:
  UU: 0
  IUB: 0
  IUR: 0
  IU: 0

BMSC:
  GMB: 0

MME:
  S11: 1
  S10: 1
  S6A: 1
  S3: 1
  S1-MME: 1

SGW:
  GXC: 0
  S11: 0
  S8B: 0
  S5: 0
  S4: 0

PDN-GW:
  SGi: 0
  S8B: 1
  GX: 1
  S6B: 0
  S5: 1
  S2C: 0
  S2B: 0
  S2A: 0

ENODEB:
  UU: 0
  X2: 1
  S1-MME: 1

TCE IP Addr:
  IPV4 Addr: 1.1.1.1

Hex: 6000 2200 2163 5400 3039 0000 0000 0000
      003F 7040 0305 0000 0000 0000 0000 1F00
      6803 0101 0101                                     335927
```



CHAPTER 55

S-GW Event Reporting

This chapter describes the record content and trigger mechanisms for S-GW event reporting. When enabled the S-GW writes a record of session events and sends the resulting event files to an external file server for processing. Each event is sent to the server within 60 seconds of its occurrence.



Note The S-GW Event Reporting feature is applicable to S-GW and SAEGW (Pure-S calls).

This chapter includes the following topics:

- [S-GW Event Reporting, on page 973](#)

S-GW Event Reporting

This chapter describes the record content and trigger mechanisms for S-GW event reporting. When enabled the S-GW writes a record of session events and sends the resulting event files to an external file server for processing. Each event is sent to the server within 60 seconds of its occurrence.



Note The S-GW Event Reporting feature is applicable to S-GW and SAEGW (Pure-S calls).

This chapter includes the following topics:

Event Record Triggers

When properly configured, the S-GW creates and sends a record in CSV format as the session events listed below occur.

- ID 1: Session Creation
- ID 2: Session Deletion
- ID 3: Bearer Creation
- ID 4: Bearer Deletion
- ID 5: Bearer Modification
 - suppress intra-system handover
 - configurable enable active to idle transition event reporting

- ID 6: Bearer Update

The following guidelines apply to the above session events:

- A session refers to a PDN connection and the default bearer associated with it.
- Bearer events refer to dedicated bearers that have been created/deleted/updated/modified.
- Bearer modifications that are intra-S-GW and intra-MME are not be reported.
- Bearers and sessions that fail to setup are reported once in a session/bearer creation record with the result code set to failure.

Event Record Elements

Each event record includes the information documented in the table below in comma separated value (CSV) ASCII format. The elements are listed in the order in which they will appear. All record elements are not available for all event triggers. If a record element cannot be populated due to incomplete information, the element is omitted and the comma separation maintained.

The following guidelines apply to record elements:

- Byte/packet counters shall not be sent in session or bearer creation messages
- Byte/packet counters include packets and bytes sent or received since the last record created for that session or bearer.
- The S-GW will attempt to populate all record elements. Values that are unavailable will not be populated.

Table 87: S-GW Event Record Elements

Event Number	Description	Format	Size (bytes)	Applicable Event Numbers
1	Event identity (ID 1 – ID 6)	Integer [1-6]	1	All
2	Event Result (3GPP 29.274 Cause Code)	Integer [1-255]	3	All
3	IMSI	Integer (15 digits)	15	All
4	IMEISV	Integer (16 digits)	16	All
5	Callid	Integer (0-500000000000)	4	All
6	Start Time (GMT)	MM/DD/YYYY-HH:MM:SS:_MS (millisecond accuracy)	18	All
7	End Time (GMT)	MM/DD/YYYY-HH:MM:SS:_MS (millisecond accuracy)	18	2, 4
8	Protocol (GTPv2)	String	5	All
9	Disconnect code (ASR 5500)	Integer [1-999]	3	All
10	Trigger Event (3GPP 29.274 request cause code)	Integer [1-15]	3	All
11	Hostname	IPv4 or IPv6 address	255	All

Event Number	Description	Format	Size (bytes)	Applicable Event Numbers
12	Origination Node	String (CLLI)	10	All
13	Origination Node Type	String (SGW HSGW PGW ...)	3	All
14	EPS Bearer ID(Default)	Integer [0-15]	1 or 2	All
15	APN Name	String	34 to 255	All
16	PGW IP Address	IPv4 or IPv6 address	7 to 55	All
17	UE IPv4 Address	IPv4 address	7 to 15	All
18	UE IPv6 Address	IPv6 address	3 to 55	All
19	Uplink AMBR	Integer (0-4000000000)	1 to 10	All
20	Downlink AMBR	Integer (0-4000000000)	1 to 10	All
21	TAI - MCC/MNC/TAC	String (MCC;MNC;TAC)	14	All
22	Cell ID (ECI)	String (28 bits)	8	All
23	EPS Bearer ID (dedicated)	Integer (0-15)	1 or 2	21
24	Result Code (success/fail)	0=fail 1=success	1	All
25	QCI	Integer[1-255]	1 to 3	All
26	Uplink MBR (bps)	Integer (0-4000000000)	1 to 10	All
27	Downlink MBR (bps)	Integer (0-4000000000)	1 to 10	All
28	Uplink GBR (bps)	Integer (0-4000000000)	1 to 10	All
29	Downlink GBR (bps)	Integer (0-4000000000)	1 to 10	All
30	Downlink Packets Sent (interval)	Integer (0-4000000000)	1 to 10	2, 4, 5, 6
31	Downlink Bytes Sent (interval)	Integer (0-500000000000)	1 to 12	2, 4, 5, 6
32	Downlink Packets Dropped (interval)	Integer (0-500000000000)	1 to 12	2, 4, 5, 6
33	Uplink Packets Sent (interval)	Integer (0-500000000000)	1 to 12	2, 4, 5, 6
34	Uplink Bytes Sent (interval)	Integer (0-500000000000)	1 to 12	2, 4, 5, 6
35	Uplink Packets Dropped (interval)	Integer (0-4000000000)	1 to 10	2, 4, 5, 6
36	MME S11 IP Address	IPv4 or IPv6 address	7 to 55	All

Event Number	Description	Format	Size (bytes)	Applicable Event Numbers
37	S1u IP Address of eNodeB	IPv4 or IPv6 address	7 to 55	All

Active-to-Idle Transitions

This table below describes how active-to-idle transitions generate event records.

Table 88: Subscriber-initiated Attach (initial) Call Flow Description

Step	Description
1	UE becomes Active (via UE or NW initiated service request)
2	Session becomes idle.
3	S-GW acknowledges idle session.
4	Bearer modification event record is created, with the following fields: <ul style="list-style-type: none"> • Start Time: Use the start time of the idle-to-active transition • End Time: Use the timestamp of the idle time • Bytes up/Bytes down: Amount of data sent between transitions • Packets up/Packets down: Number of packets sent between transitions

3GPP 29.274 Cause Codes

Table 89: 3GPP 29.274 Cause Codes

Cause Value	Meaning
Request	
2	Local Detach
3	Complete
4	RAT changed from 3GPP to Non-3GPP
5	ISR deactivation
6	Error Indication received from RNC/eNodeB
Accept	
16	Request accepted
17	Request accepted partially

Cause Value	Meaning
18	New PDN type due to network preference
19	New PDN type due to single address bearer only
Reject	
64	Context Not Found
65	Invalid Message Format
66	Version not supported by next peer
67	Invalid length
68	Service not supported
69	Mandatory IE incorrect
70	Mandatory IE missing
71	Reserved
72	System failure
73	No resources available
74	Semantic error in the TFT operation
75	Syntactic error in the TFT operation
76	Semantic errors in packet filter(s)
77	Syntactic errors in packet filter(s)
78	Missing or unknown APN
79	Unexpected repeated IE
80	GRE key not found
81	Relocation failure
82	Denied in RAT
83	Preferred PDN type not supported
84	All dynamic addresses are occupied
85	UE context without TFT already activated
86	Protocol type not supported
87	UE not responding
88	UE refuses

Cause Value	Meaning
89	Service denied
90	Unable to page UE
91	No memory available
92	User authentication failed
93	APN access denied - no subscription
94	Request rejected
95	P-TMSI Signature mismatch
96	IMSI not known
97	Semantic error in the TAD operation
98	Syntactic error in the TAD operation
99	Reserved Message Value Received
100	Remote peer not responding
101	Collision with network initiated request
102	Unable to page UE due to Suspension
103	Conditional IE missing
104	APN Restriction type Incompatible with currently active PDN connection
105	Invalid overall length of the triggered response message and a piggybacked initial message
106	Data forwarding not supported
107	Invalid reply from remote peer
116 to 239	Spare. This value range is reserved for Cause values in rejection response message.
Sub-Causes	
NO_INFORMATION	
ABORTED_BY_SESSION_DELETION	
NO_RESPONSE_FROM_MME	
INTERNALLY_TRIGGERED	
BEARERS_IN_MULTIPLE_PDN_CONNECTIONS	
EXPECTED_BEARERS_MISSING_IN_MESSAGE	
UNEXPECTED_BEARERS_PRESENT_IN_MESSAGE	



CHAPTER 56

S-GW Paging Enhancements

- [Feature Description, on page 979](#)
- [How It Works, on page 980](#)
- [Limitations, on page 981](#)
- [Configuring High Priority DDN Interaction Feature, on page 982](#)
- [Monitoring and Troubleshooting High Priority DDN Interaction Feature, on page 983](#)

Feature Description

S-GW Paging includes the following scenarios:

Scenario 1: S-GW sends a DDN message to the MME/S4-SGSN nodes. MME/S4-SGSN responds to the S-GW with a DDN Ack message. While waiting for the DDN Ack message from the MME/S4-SGSN, if the S-GW receives a high priority downlink data, it does not resend a DDN to the MME/S4-SGSN.

Scenario 2: If a DDN is sent to an MME/S4-SGSN and TAU/RAU MBR is received from another MME/S4-SGSN, S-GW does not send DDN.

Scenario 3: DDN is sent to an MME/S4-SGSN and DDN Ack with Cause #110 is received. DDN Ack with cause 110 is treated as DDN failure and standard DDN failure action procedure is initiated.

To handle these scenarios, the following two enhancements have been added to the DDN functionality:

- High Priority DDN at S-GW
- MBR-DDN Collision Handling

These enhancements support the following:

- Higher priority DDN on S-GW and SAEGW, which helps MME/S4-SGSN to prioritize paging.
- Enhanced paging KPI and VoLTE services.
- DDN message and mobility procedure so that DDN is not lost.
- MBR guard timer, which is started when DDN Ack with temporary HO is received. A new CLI command **ddn temp-ho-rejection mbr-guard-timer** has been introduced to enable the guard timer to wait for MBR once the DDN Ack with cause #110 (Temporary Handover In Progress) is received.
- TAU/RAU with control node change triggered DDNs.

In addition to the above functionality, to be compliant with 3GPP standards, support has been enhanced for Downlink Data Notification message and Mobility procedures. As a result, DDN message and downlink data which triggers DDN is not lost. This helps improve paging KPI and VoLTE success rates in scenarios where DDN is initiated because of SIP invite data.

Licensing

This is a license-controlled feature. Contact your Cisco account or support representative for detailed licensing information.

How It Works

This section describes working of these features related to S-GW Paging.

High Priority DDN at S-GW

High Priority DDN at S-GW

1. S-GW sends a Downlink Data Notification message to the MME/S4-SGSN node for which it has control plane connectivity for the given UE.
2. The MME/S4-SGSN responds to the S-GW with a Downlink Data Notification Ack message.
3. The S-GW, while waiting for the user plane to be established, might send a second Download Data Notification based on the priority of received data. The following table lists the cases when it will happen.
4. The following table lists different scenarios with different DDN priorities and the action taken by the S-GW.

Table 90: DDN Priority Scenarios

Scenario	Action Taken by S-GW Action Taken by S-GW Prior This Feature	Action Taken by S-GW Action Taken by S-GW Post This Feature
ARP Priority of second bearer is higher than the first bearer on which first DDN was sent.	No DDN was sent.	Sends DDN message with higher priority to the MME/S4-SGSN.
ARP Priority of second bearer is higher than the first bearer on which first DDN was sent.	Buffers these downlink data packets and the does not send a new DDN. However, separate Paging DDN is always sent out and this restriction does not apply to it.	Buffers these downlink data packets and the does not send a new DDN. However, separate Paging DDN is always sent out and this restriction does not apply to it.
S-GW has sent the second DDN message indicating higher priority and receives extra downlink data packets for this UE.	Buffers these downlink data packets and the does not send a new DDN.	Buffers these downlink data packets and the does not send a new DDN.



Important Separate paging is always sent.

MBR-DDN Collision Handling

The following table lists different MBR-DDN collision scenarios and action taken by S-GW to handle these scenarios:

Table 91: MBR-DDN Collision Handling Scenarios

Scenario	Action Taken by S-GW Action Taken by S-GW Prior This Feature	Action Taken by S-GW Action Taken by S-GW Post This Feature
DDN is sent to an MME/S4-SGSN and TAU/RAU MBR is received from another MME/S4-SGSN without any data TEIDs.	No DDN was sent.	DDN is triggered to this new control node as part of mobility handover process.
DDN is sent to an MME/S4-SGSN and DDN Ack with Cause #110 is received.	DDN Ack with cause 110 is treated as DDN failure and standard DDN failure action procedure is initiated.	S-GW starts a guard timer and wait for TAU/RAU MBR from the new MME/S4-SGSN. The timer is stopped if any MBR or DDN failure indication is received. But, if none of them is received, and the timer expires all buffered downlink data packets are flushed. If this is followed by mobility handover without any data TEIDs, DDN is resent to this new control node as well.
MBR received with bearer context to be removed.	There is a possibility that DDN could be sent with EBIs corresponding to bearers marked for deletion.	Bearers marked for deletion are not included in any of the DDN messages.

Limitations

High Priority DDN at S-GW

This section lists the limitations for High Priority DDN at S-GW feature.

1. High Priority DDN is always enabled whenever the license is available.
2. High priority DDN is sent only once. Any further higher priority data does not trigger another DDN.
3. DDN delay timer and DDN throttling is not applicable to High Priority DDN.
4. Separate Paging DDN is always sent out and above restriction does not apply to it.
5. No-user-connect behavior restarts the moment high priority DDN is sent out.

MBR-DDN Collision Handling

This section lists the limitations for MBR-DDN Collision Handling feature.

1. EBI of a bearer marked for removal is not sent in any of the DDN messages.
2. TAU/RAU triggered DDN is sent only once and is never reattempted even if aborted due to the collision of MBR with DDN at the S-GW Ingress.
3. DDN delay and throttling are not applicable to the TAU/RAU triggered DDN.
4. No-user-connect behavior restarts the moment high priority DDN is sent out.
5. High Priority DDN is not sent if high priority downlink data is received:
 - After DDN Ack with Cause #110 is received
 - Before any MBR is received
6. Separate paging IE is not supported for TAU/RAU triggered DDN.
7. If DDN Ack with cause #110 is received and then later a downlink packet matches the configured 3-tuple of "Separate Paging", then also "Separate Paging DDN" is not sent as the UE is undergoing handoff.
8. The MBR guard timer is not restarted when the DDN Ack with cause #110 is received while the MBR guard timer is running.

Configuring High Priority DDN Interaction Feature

Operators can use this CLI command to enable guard timer to wait for MBR once the DDN Ack with cause #110 (Temporary Handover In Progress) is received.

Configuring mbr-guard-timer

This CLI sets the guard timer to wait for a MBR when DDN Ack with Cause #110 temp-ho-rejection) is received.

If the guard timer expires and if no MBR of any type or DDN Failure Indication is received, all the buffered downlink data is flushed out and paging flags are reset.

If the guard timer is running and any MBR is received, the timer is stopped and no further action is taken.

If the guard timer is running and DDN Failure Indication is received, the timer is stopped and standard DDN failure action is taken.

By default, this CLI command is always enabled.

```

configure
  context context_name
    sgw-service service_name
      ddn temp-ho-rejection mbr-guard-timer time_in_seconds
      { no | default } ddn temp-ho-rejection mbr-guard-timer
    end
  
```

Notes:

- **no**: Disables the guard timer.
- **default**: Enables the guard timer and sets it to the default value, 60 seconds.

- **temp-ho-rejection:** Action to be taken when peer node indicates temporary rejection of paging due to handover-in-progress.
- **mbr-guard-timer:** Sets the guard timer for a MBR when DDN Ack with Cause #110 (temp-ho-rejection) is received. When the timer expires, S-GW flushes all the buffered downlink data packets. The range of this timer is from 60 seconds to 300 seconds. Default timer value is 60 seconds.

Verifying the Configuration

The configuration of this feature can be verified using the following commands from the `exec` mode:

- `show sgw-service statistics all`
- `show sgw-service [name <service-name> | all]`
- `show saegw-service statistics all function sgw`

See the section [Monitoring and Troubleshooting High Priority DDN Interaction Feature, on page 983](#) for the command output.

Monitoring and Troubleshooting High Priority DDN Interaction Feature

The following section describes commands available to monitor and troubleshoot "High Priority DDN" & "DDN-MBR Collision Handling" Features .

Show Commands for High Priority DDN Interaction Feature

`show sgw-service [name <service-name> | all]`

This CLI is enhanced to show the MBR-guard-timer configuration which can be a value between "60-300 Seconds" when enabled OR "Disabled". The MBR-guard-timer is started when a DDN Ack with Temporary-HO-Rejection (Cause #110) is received.



Important If the MBR-guard-timer is disabled, DDN Ack with Temporary-HO-Rejection is treated as DDN Failure Indication.

This command displays the following output:

```
show sgw-service name sgw-srv
Service name           : sgw-srv
Service-Id            : 18
Context                : ingress
Accounting context     : ingress
Accounting gtp group  : default
Accounting mode        : Gtp
Accounting stop-trigger : Default
Status                 : STARTED
Egress protocol        : gtp-pmip
```

show sgw-service statistics all

```

Ingress EGTP service           : egtp-sgw-ingress
Egress context                 : ingress
Egress EGTP service           : egtp-sgw-egress
Egress MAG service             : n/a
IMS auth. service              : n/a
Peer Map                       : n/a
Access Peer Map               : n/a
Accounting policy              : n/a
Newcall policy                 : n/a
Internal QOS Application       : Backward-compatible
QCI-QOS mapping table         : n/a
Event Reporting                : Disabled
DDN Throttling                 : Disabled
Page UE for PGW initiated proc: Disabled
Temp-Failure Handling for DBR proc: Disabled
PGW Ctrl FTEID in Relocation Create Session Response: Enabled
...
....
ddn success-action no-user-connect ddn-retry-timer: 60
ddn failure-action pkt-drop-time: 300
ddn isr-sequential-paging delay-time: 10
MBR Guard Timer for DDN Ack with Temporary-HO-Rejection: 60-300 seconds/Disabled

Idle timeout                   : n/a
PLMN ID List                   : Not defined
Subscriber Map Name: smap
SAEGW service                  : saegw
EGTP NTSR: Disabled
  Session Hold Timer: n/a
  Timeout: n/a

GTP-C Load Control Profile     : Not Defined
GTP-C Overload Control Profile : Not Defined

```

show sgw-service statistics all

This CLI command has been enhanced to show the following:

- Number of times 'High Priority Paging' is triggered and number of times it could not be triggered as it was already sent. This shows data corresponding to only S-GW service(s) which is part of SAEGW service(s).
- Number of times DDN Ack with a cause #110 is received and number of times TAU/RAU MBR with control node change triggers a DDN automatically.
- Number of packets and bytes discarded when MBR-guard-timer expires; this timer is started when a DDN Ack with Temporary-HO-Rejection (Cause #110) is received.
- This CLI shows data only corresponding to standalone sgw-service(s).

This command displays the following output:

```

show sgw-service statistics all
...
...
Paging Statistics:
Requests:                3      Success :                2
Rejects:                 1      Failures:                0
UE State Transitions:
  Idle-to-Active:        0      Active-to-Idle:         1

```



```

Data Statistics Related To Paging:
Packets Buffered:          3   Bytes Buffered:          15
Packets Discarded:        9   Bytes Discarded:         45
Idle Mode ACL Statistics:
  Packets Discarded:      0   Bytes Discarded:         0

Data Discarded By Reason-Type:
Shared Buffer Full:
  Packets Discarded:      0   Bytes Discarded:         0
Dedicated Buffer Full:
  Packets Discarded:      0   Bytes Discarded:         0
S1U State Inactive:
  Packets Discarded:      0   Bytes Discarded:         0
Paging Throttled:
  Packets Discarded:      0   Bytes Discarded:         0
Paging Failure:
  Packets Discarded:      9   Bytes Discarded:         45
No User Connect Data Flushed:
  Packets Discarded:      0   Bytes Discarded:         0
MBR Guard Timer Expiry Flushed Data:
  Packets Discarded:      0   Bytes Discarded:         0
Buffered Data Flushed:
  Packets Discarded:      0   Bytes Discarded:         0

High Priority Paging Statistics:
  Initiated:              1   Suppressed:              1

Handover Paging Statistics:
  DDN Ack with Temporary-HO-Rejection (Cause #110):      0
  TAU/RAU MBR Triggered DDN:                            1
...

```

show saegw-service statistics all function sgw

This CLI is enhanced to show the following:

- Number of times 'High Priority Paging' was triggered and number of times it could not be as it was already sent.
- Number of times DDN Ack with a cause #110 is received and number of times TAU/RAU MBR with control node change triggers a DDN automatically.
- Data only corresponding to the S-GW service(s) which is associated with a SAEGW service(s).
- Number of packets and bytes discarded when MBR-guard-timer expires; this timer is started when a DDN Ack with Temporary-HO-Rejection (Cause #110) is received
- Number of packets and bytes discarded when MBR-guard-timer expires; this timer is started when a DDN Ack with Temporary-HO-Rejection (Cause #110) is received
- Packets/Bytes dropped due to MBR-guard-timer expiry are not shown for collapsed calls.



Important

Paging packets dropped statistics are not incremented for collapsed calls and hence the newly added counter of "MBR Guard timer Expiry Flushed Data" is also not updated in that case.

This command displays the following output:

```
show saegw-service statistics all function sgw
```

```

show saegw-service statistics all function sgw
Paging Statistics:
  Requests:                3    Success :                2
  Rejects:                 1    Failures:                0
  UE State Transitions:
    Idle-to-Active:        0    Active-to-Idle:         1

Data Statistics Related To Paging:
  Packets Buffered:        3    Bytes Buffered:         15
  Packets Discarded:       9    Bytes Discarded:        45
  Idle Mode ACL Statistics:
    Packets Discarded:     0    Bytes Discarded:        0

Data Discarded By Reason-Type:
  Shared Buffer Full:
    Packets Discarded:     0    Bytes Discarded:        0
  Dedicated Buffer Full:
    Packets Discarded:     0    Bytes Discarded:        0
  SIU State Inactive:
    Packets Discarded:     0    Bytes Discarded:        0
  Paging Throttled:
    Packets Discarded:     0    Bytes Discarded:        0
  Paging Failure:
    Packets Discarded:     9    Bytes Discarded:        45
  No User Connect Data Flushed:
    Packets Discarded:     0    Bytes Discarded:        0
  MBR Guard Timer Expiry Flushed Data:
    Packets Discarded:     0    Bytes Discarded:        0
  Buffered Data Flushed:
    Packets Discarded:     0    Bytes Discarded:        0

High Priority Paging Statistics:
  Initiated:                1    Suppressed:              1

Handover Paging Statistics:
  DDN Ack with Temporary-HO-Rejection (Cause #110):  0
  TAU/RAU MBR Triggered DDN:                          1

```



CHAPTER 57

S-GW Restoration Support

This chapter describes the S-GW Restoration support feature.

- [Feature Description, on page 987](#)
- [How it Works, on page 988](#)
- [Configuring S-GW Restoration Support, on page 989](#)
- [Monitoring and Troubleshooting S-GW Restoration Support, on page 990](#)

Feature Description

S-GW Restoration helps in handling the S-GW failure in the EPC network. It allows affected PDNs that fail due to S-GW to be restored by selecting another S-GW to serve the affected PDNs. This avoids unnecessary flooding of signaling for PDN cleanup.

The P-GW maintains the sessions in case path failure is detected or if S-GW restart is detected during recovery IE on GTP-C signaling. The P-GW will ensure that any dropped packets in this scenario are not charged. The P-GW also rejects any bearer additions or modification requests received for the PDN connection maintained after the S-GW failure detection. This occurs until the PDN is restored.

Once the session has been restored by the MME and the P-GW receives a Modify Bearer Request from the restarted S-GW or a different S-GW, then the P-GW continues forwarding any received downlink data and start charging them.

When a subscriber is in S-GW restoration phase, all RARs (except for Session Termination) reject the PCEF. The P-GW rejects all internal updates which can trigger CCR-U towards the PCRF. The P-GW triggers a CCR-U with AN-GW changes for the PDNs that are restored if the S-GW has changed on restoration.

The MME/S4-SGSN is locally configured to know that the P-GW in the same PLMN supports the S-GW restoration feature. When this feature is enabled at the P-GW, it supports it for all S-GWs/MMEs.



Important Only MME/S4-SGSN triggered S-GW restoration procedure will be supported.

S-GW restoration detection based on GTP-U path failure shall not be considered for this release. GTP-C path failure detection should be enabled for enabling this feature.

S-GW restoration detection based on GTP-U path failure shall not be considered for this release. GTP-C path failure detection should be enabled for enabling this feature.

The P-GW Restart Notification may also be used to signal that the peer P-GW has failed and not restarted. In this case, the P-GW Restart Notification contains a cause value: P-GW not responding. While sending the PRN, the S-GW includes the cause with this new cause value depending on the echo response.

Relationships to Other Features

GTP-C path failure detection should be enabled for enabling this feature.

How it Works

Changes at P-GW

If a path failure is detected at the Demux, then the path failure notification is sent to all session managers at the P-GW. Next, the session manager cleans up the ongoing transactions. Once all the transactions are deleted, the sessmgr-egtpc deletes the tunnels by adding them into the pacing queue.

The P-GW will not delete the session immediately after detecting path failure with the S-GW restoration in place. The P-GW discards downlink packets received for a maintained PDN connection and stop charging for maintained PDN connections after an S-GW failure that has not been restored.

The MME/S4-SGSN controls the pace of the S-GW relocations to avoid core network node overload. The MME/S4-SGSN prioritizes the S-GW relocation for UEs engaged in a Service Request for RAU/TAU procedures over UEs which are not engaged in any mobility product procedure and do not have a signaling connection to MME/S4-SGSN.

If a session is marked for S-GW restoration and if a new request results in context replacement, then the existing session is aborted followed by a new request indication event.

Changes at the E-GTPC

When the Demux informs the eGTP-C about the path failure, abort all active procedures. The abort procedure indicates to the P-GW if S-GW restoration is enabled to for the session. Add all the session in the queue and start the session hold timer for S-GW. The MME restores these sessions by relocating sessions to the new or the same S-GW. When the MBReq is received at the P-GW and if the session is marked with S-GW restoration, then the S-GW flag is reset. At this point, the session hold timer expires and S-GW restoration is removed.

Changes at the MME and SGSN

When the MME and SGSN detects path failure towards the S-GW and the MME supports S-GW restoration, then MME relocates sessions from the failed S-GW to another S-GW.

S-GW restoration is supported in MME from Release 21.3 onwards. However, for SGSN, S-GW restoration is not supported.

Demux Failure Detection

The EGTPIN manager detects a path failure and informs all session managers about the failure. Then, the session manager gets the path failure notification and S-GW restoration is enabled so it will stop all ongoing transactions. The Sessmgr-egtpc informs the P-GW-driv about the path failure. The P-GW deletes the session.

Next, the eGTP-C starts the session hold timer. If the MME triggers the S-GW service restoration before the session hold up timer, then sessions from the old S-GW will move to the new S-GW. This ensures that no sessions are handed over and none are deleted.

Once the session hold timer expires, all the sessions with that peer are cleaned up. At this point, new sessions are not moved to the new S-GW.



Important If the S-GW goes down and comes back up in a very short interval, then the P-GW will not detect the path failure. In this case, S-GW restoration does not occur. If the old S-GW comes up again before the hold timer expires, then there is a chance that only some partial sessions move to the new S-GW. In this case, the eGTP-C does not need to delete the remaining sessions with that peer. The eGTP-C will stop the timer.

If the session manager detects the path failure, then it informs the Demux manager. The above, scenario still occurs in this case.

After detecting the path failure, the Demux will not send ECHO messages towards the S-GW. If the new session addition occurs or a new session is restored from the node, then the Demux sends the ECHO messages towards the peer.

Standards Compliance

The S-GW Restoration functionality complies with the following standards:

- 3GPP TS 23.007: Restoration procedures
- 3GPP TS 29.212: Policy and Charging Control over Gx reference point

Configuring S-GW Restoration Support

The session-hold timer is a configurable parameter. The operator can configure this parameter using the **egtpc sgw-restoration session-hold timeout seconds** CLI command.

The **sgw-restoration** keyword enables S-GW restoration functionality and configure session hold timeout on a P-GW service.

When the P-GW detects that the peer S-GW is down (detection is based on restart counter change or PATH failure due to an ECHO response failure), it moves all PDN sessions associated with the peer S-GW to the SGW-RESTORATION-STATE. Also the P-GW starts a timer with the value provided for session-hold timeout per peer S-GW. After timer expiry, the P-GW cleans up all the sessions which are in the SGW-RESTORATION-STATE.



Important By default, S-GW restoration support will not be enabled.

Sample Configuration

Use the following example to enable S-GW Restoration Support.

```
configure
  context context_name
    pgw-service service_name
      egtpc sgw-restoration session-hold timeout seconds
      { default | no } egtpc sgw-restoration session-hold
    end
```

Notes:

- **session-hold timeout** configures session hold timer for S-GW restoration.
- *seconds* must be an integer from 1 to 3600. Default: 0 (disabled).
- On S-GW failure indication, the P-GW checks if the S-GW restoration feature is enabled or not. If enabled, the P-GW maintains all the affected sessions for session-hold timeout. After session-hold timeout, the P-GW clears all the sessions which are not recovered yet.

Verifying the S-GW Configuration

To verify the S-GW Restoration configuration, use the following command:

```
show pgw-service all
```

The following fields have been added to display configuration information for S-GW restoration.

- EGTP SGW Restoration Handling
- Session Hold Timer
- Timeout

Monitoring and Troubleshooting S-GW Restoration Support

This section includes show commands in support of the S-GW Restoration.

S-GW Show Commands

This section provides information regarding show commands and/or their outputs in support of the S-GW Restoration.

show ims-authorization policy-control statistics

The following fields have been added to display the statistics introduced in support of S-GW Restoration Support.

- SGW Restoration
- RAR Reject
- Internal Updates Dropped
- Revalidation Timeout

- Pending Updates

show pgw-service statistics all

The following counters have been added to display S-GW Restoration Support.

- SGW Restoration Statistics
- PDNs Total
- In Restoration State
- Recovered
- Released
- Drops During SGW Restoration State
- Packets
- Bytes

show subscribers pgw-only full all

The following fields and counters have been added to display S-GW Restoration Support.

- Bearer State
- in packet dropped sgw restoration state
- in bytes dropped sgw restoration state
- out packet dropped sgw restoration state
- out bytes dropped sgw restoration state

show subscribers pgw-only full all



CHAPTER 58

Support for One Million S1-U Peer-to-Peer Connections

This chapter describes StarOS support for the One Million S1-U Peer-to-Peer Connections feature.

- [Feature Description, on page 993](#)
- [How it Works, on page 993](#)
- [Configuring the Feature, on page 994](#)
- [Show Command Output, on page 995](#)

Feature Description

Due to production forecasts, support has been added to the StarOS for one million S1-U connections on a single S-GW.

The S1-U interface is the user plane interface carrying user data between an eNodeB and an S-GW received from the terminal. The StarOS now has the capability to scale the number of S1-U peers to one million per VPN context.

A CLI command enables operators to set the number of S1-U peers for which statistics should be collected. The limit is restricted to less than one million peers (128k) due to StarOS memory limitations.

How it Works

The gtpumgr uses the following guidelines while allocating peers:

- When a session installation comes from the Session Manager, a peer is created. If statistics are maintained at the Session Manager, the gtpumgr also creates the peer record with the statistics.
- Peer records are maintained per service.
- The number of peers is maintained at the gtpumgr instance level. The limit is one million S1-U peers per gtpumgr instance.
- If the limit of one million peers is exceeded, then peer creation fails. It causes a call installation failure in the gtpumgr, which leads to an audit failure if an audit is triggered.

The feature changes impact all the interfaces/services using the `gtpu-service` including GGSN/S4-SGSN/S-GW/P-GW/SAEGW/ePDG/SaMOG/HNB-GW/HeNB-GW for:

- The Gn and Gp interfaces of the General Packet Radio Service (GPRS)
- The Iu, Gn, and Gp interfaces of the UMTS system
- The S1-U, S2a, S2b, S4, S5, S8, and S12 interfaces of the Evolved Packet System (EPS)

Recovery/ICSR Considerations

- After a session manager/`gtpumgr` recovery or after an ICSR switchover, the same set of peers configured for statistics collection is recovered.
 - Peers with 0 sessions and without statistics are not recovered.
 - Peers with 0 sessions and with statistics are recovered.
 - Peers with Extension Header Support disabled are recovered.
- While upgrading from a previous release, ensure the newer release chassis **`gtpu peer statistics threshold`** is equal to or greater than the previous release. This way the GTPU peer statistics are preserved during the upgrade. For example, if you are upgrading from StarOS release 19.0 to 20.2, and the StarOS 19.0 system has 17,000 GTPU sessions, then configure the threshold on the StarOS 20.2 system to 17,000 as well.

Configuration and Restrictions

- Due to the large number of GTP-U entities connecting to the StarOS, Cisco recommends disabling the GTP-U Path Management feature.
- The configured threshold is not the hard upper limit for statistics allocation because of the distributed nature of system. It is possible that total GTP-U peers with statistics exceeds the configured threshold value to some extent.
- It is assumed that all 1 million peers are not connected to the node in a point-to-point manner. They are connected through routers.
- There will not be any ARP table size change for the StarOS to support this feature.

Configuring the Feature

This section describes how to configure support for the One Million S1-U Peer Connections feature.

`gtpu peer statistics threshold`

This new command has been added to *Context Configuration Mode* to specify the number of S1-U peers for which the StarOS will maintain statistics.

Use the following example to configure the feature:

```
configure
  context context_name
    gtpu peer statistics threshold value
  end
```

Notes :

- *value* represents the number of S1-U peers for which statistics will be maintained. Valid entries are from 16000 to 128000. The default setting is 16000.
- The threshold cannot be configured to a lower value than the current value.

Show Command Output

This section describes the show command output changes made to support the One Million S1-U Peers feature.

clear gtpu statistics peer-address

The **all** keyword has been added to this command to enable operators to clear statistics for all S1-U peers for which statistics are being maintained.

```
clear gtpu statistics peer-address all
```

show gtpu statistics

The output of this command has been enhanced to show the total number of GTPU peers, and the total number of GTPU peers configured for statistics collection.

- Total GTPU Peers:
- Total GTPU Peers with stats:

show session subsystem facility sessmgr

The output of this command has been enhanced to provide the total number of S1-U (GTP-U) peers that are configured for statistics collection.

- Total Gtpu Peers with stats

show session subsystem facility sessmgr



CHAPTER 59

Support for Presence Reporting Area and Extended QOS on Offline Charging Interface for P-GW and SAEGW

- [Feature Summary and Revision History, on page 997](#)
- [Feature Description, on page 998](#)
- [Handling Single and Multi-Presence Reporting Area on Rf Interface, on page 998](#)
- [Configuring IMS Authorization Service at Context Level, on page 1001](#)
- [Configuring AAA Group, on page 1002](#)

Feature Summary and Revision History

Summary Data

Applicable Product(s) or Functional Area	P-GW SAEGW
Applicable Platform(s)	<ul style="list-style-type: none">• ASR 5500• i-CUPS• VPC-DI• VPC-SI
Feature Default	<ul style="list-style-type: none">• Disabled - Configuration Required
Related Changes in This Release	Not applicable
Related Documentation	<ul style="list-style-type: none">• <i>P-GW Administration Guide</i>• <i>SAEGW Administration Guide</i>

Revision History

Revision Details	Release
This release supports Diameter offline charging on Rf interface for P-GW and SAEGW.	21.20.5

Feature Description

P-GW and SAEGW supports the following Attribute Value Pairs (AVP) and functionalities in diameter offline charging (RF) interface.

- **Originating-User-Location-Info** –This AVP holds value of 3GPP **User-Location-Info** AVP at the Packet Switch (PS) Information AVP in the Rf accounting (ACR) message for Long-Term Evolution (LTE) and General Packet Radio Service (GPRS).
- **Originating BSID** –This AVP holds value of 3GPP2-BSID AVP for Enhanced High-Rate Packet Data (eHRPD) at the PS Information AVP in the Rf accounting (ACR) message.
- **Grouped QoS-Information AVP with 5G-related sub-AVPs**– This AVP is enhanced with extended bit rates using 5G related sub AVP's. The 5G related sub AVP's are available at Service Data Container (SDC) level and **APN-AMBR** AVP values at PS level.
- **Presence Reporting Area Information** –P-GW and SAEGW supports the core network of single and Multi Presence Reporting Area (PRA) information for only LTE and GPRS at Service Data Container (SDC) level in Rf accounting (ACR) message.
- **Change-Condition** –This AVP holds value of 24 for **Change of UE Presence in Presence Reporting Area** at SDC level in Rf accounting (ACR) message.

Limitations

The following are the limitations:

- User Equipment (UE) Dedicated Presence Reporting Area is not supported.
- Presence-Reporting-Area-Element-List AVP not supported. This AVP is applicable only for UE-Dedicated PRA support.

Handling Single and Multi-Presence Reporting Area on Rf Interface

During an IP-CAN session, the Policy and Charging Rules Function (PCRF) determines whether the reports for change of the UE presence in the Presence Reporting Area (PRA) are required for an IP-CAN session. If the reporting is required for the IP-CAN session, the PCRF provides PRA information AVP, which contains the PRA identifier within the **Presence-Reporting-Area-Identifier** AVP to the P-GW. The PCRF activates the reporting changes of the UE presence in the PRA by subscribing to the **CHANGE_OF_UE_PRESENCE_IN_PRESENCE_REPORTING_AREA_REPORT** event trigger at the P-GW at any time during the entire IP-CAN session.

When the UE enters or leaves the PRA, P-GW reports the **CHANGE_OF_UE_PRESENCE_IN_PRESENCE_REPORTING_AREA** change condition in Rf messages (ACR-Interim). In addition, the P-GW reports the PRA identifier within **Presence-Reporting-Area-Identifier** AVP included in `Presence-Area-Information` AVP when UE is inside the PRA.

Handling both single and multiple Presence Reporting Area

To handle both single and multiple PRA:

- Add the **Change of UE Presence in Presence Reporting Area** value in **Change-Condition** AVP at SDC level every time when change of UE presence in PRA is received from access side along with other change conditions.
- P-GW includes:
 - extended MBR, GBR and APN-AMBR AVP values, if it received from PCRF or access side, to send in the accounting messages at SDC level
 - extended APN-AMBR AVP values, if it received from access or PCRF side, to send in the accounting messages at PS level
- Set the **Originating-User-Location-Info** AVP value during session creation for LTE/S4-SGSN RAT type when ULI IE received from access side and send value in ACR-Start message over Rf interface. Once Originating-User-Location-Info value is set, same value is sent in subsequent messages irrespective of any type of Hand Over (HO) for P-GW service.
- Set the **Originating-BSID** AVP value during session creation for eHRPD RAT type and send value in the ACR-Start message over Rf interface. Once Originating-BSID value is set, same value is sent in subsequent messages irrespective of any type of HO for P-GW service.



Note Originating-User-Location-Info AVP and Originating-BSID AVP values are not supported during session creation for 3G and WI-FI RAT types.

PRA Information IE are present in following messages:

- Create Session Request
- Create Bearer Response
- Modify Bearer Request
- Update Bearer Response

Behavior Matrix

The following table describes message type behavior for E-UTRAN.

Table 92: E-UTRAN

Message Type	Presence-Reporting-Area-Information AVP	Originating-User-Location-Info AVP	Originating-BSID AVP
Create-Session-Request	-	ACR-Start	ACR-Start
Modify-Bearer-Request	ACR-Interim	ACR-Interim	ACR-Interim
Create-Bearer-Response	ACR-Interim	ACR-Interim	ACR-Interim
Delete-Session-Request	ACR-Stop	ACR-Stop	ACR-Stop
Delete-Bearer-Command	ACR-Interim/Stop	ACR-Interim/Stop	ACR-Interim/Stop
Update-Bearer-Response	ACR-Interim	ACR-Interim	ACR-Interim
Delete-bearer-Request	ACR-Interim/Stop	ACR-Interim/Stop	ACR-Interim/Stop

The following table describes RAT type behavior.

Table 93: RAT Type

RAT Type	Presence-Reporting-Area-Information AVP	Originating-User-Location-Info AVP	Originating-BSID AVP
3G/2G	Not Supported	Supported	Not Supported
E-UTRAN	Supported	Supported	Not Supported
NB-IOT	Not Supported	Not Supported	Not Supported
Trusted-Wifi	Not Supported	Not Supported	Not Supported
Untrusted-Wifi	Not Supported	Not Supported	Not Supported
eHRPD	Not Supported	Not Supported	Supported

The following table describes Handoff expected behavior.

Table 94: Handoff

Handoff	Presence-Reporting-Area-Information AVP	Originating-User-Location-Info AVP	Originating-BSID AVP
E-UTRAN --> NB-IOT	Not Supported	Supported	Not Supported
NB-IOT --> E-UTRAN	Not Supported	Not Supported	Not Supported
E-UTRAN->3G2G	Not Supported	Supported	Not Supported

Handoff	Presence-Reporting-Area-Information AVP	Originating-User-Location-Info AVP	Originating-BSID AVP
E-UTRAN E-UTRAN	Not Supported	Supported	Not Supported
3G2G 3G2G->E-UTRAN	Not Supported	Supported	Not Supported
3G 3G->E-UTRAN->3G	Not Supported	Supported	NotSupported
E-UTRAN->WIFI	Not Supported	Supported	Not Supported
E-UTRAN E-UTRAN->E-UTRAN	Supported	Supported	Not Supported
WIFI->E-UTRAN	Supported	Not Supported	Not Supported
WIFI WIFI->E-UTRAN->WIFI	Not Supported	Not Supported	Not Supported
E-UTRAN --> eHRPD --> E-UTRAN	Supported	Supported	Not Supported
eHRPD --> E-UTRAN	Supported	Not Supported	Not Supported
eHRPD --> E-UTRAN --> eHRPD	Not Supported	Not Supported	Supported

Configuring IMS Authorization Service at Context Level

Use the following example to configure IMS Authorization service at context level for IMS subscribers in LTE/ GPRS networks.

```

configure
  context <context_name>
    ims-auth-service <imsa_service_name>
      policy-control
        diameter origin endpoint <endpoint_name>
        diameter dictionary <dictionary>
        diameter encode-supported-features
      extended-bw-newradio multiple-pra cno-uli
        diameter host-select table { 1 | 2 } algorithm
      round-robin
        diameter host-select row-precedence <precedence_value>
      table { 1 | 2 } host <primary_host_name> [ realm <primary_realm_id> ] [ secondary
        host <secondary_host_name> [ realm <secondary_realm_id> ] ] [ -noconfirm ]
      exit

```

Notes:

- <context_name> must be the name of the context where you want to enable IMSA service.

- *<imsa_service_name>* must be the name of the IMSA service to be configured for Rf interface authentication.
- **extended-bw-newradio**: Enables Extended Bandwidth with New-Radio feature.
- **multiple-pra** : Enables Multiple Presence Reporting Area Information Reporting feature.
- **cno-uli** : Enables Presence Reporting Area Information Reporting feature.

Configuring AAA Group

Use the following configuration commands to configure the Accounting group for Rf interface.

```
configure
context context_name
aaa group group_name
diameter accounting dictionary {aaa-custom4 | aaa-custom3}
diameter accounting endpoint rf
diameter accounting server rf_server priority 1
exit
```

Notes:

- **aaa group** *group_name*: Specifies the AAA server group. *group_name* must be an alphanumeric string of 1 through 63 characters.
- **diameter accounting dictionary** *{aaa-custom4 | aaa-custom3}*: Enables *aaa-custom4* and *aaa-custom3* diameter accounting dictionaries.



Note The Presence Reporting Area (PRA) and Extended QOS on Offline Charging Interface feature supports only *{aaa-custom4 | aaa-custom3}* dictionaries.

- **diameter accounting endpoint** : Enables diameter accounting endpoint on Rf interface.
- **diameter accounting server** *rf_server priority 1*: Enables multiple rf server priorities.



CHAPTER 60

Traffic Policing and Shaping

This chapter describes the support of per subscriber Traffic Policing and Shaping feature on Cisco's Chassis and explains the commands and RADIUS attributes that are used to implement this feature. The product Administration Guides provide examples and procedures for configuration of basic services on the system. It is recommended that you select the configuration example that best meets your service model, and configure the required elements for that model, as described in the respective product Administration Guide, before using the procedures in this chapter.



Important Traffic Policing and Shaping is a licensed Cisco feature. A separate feature license may be required. Contact your Cisco account representative for detailed information on specific licensing requirements. For information on installing and verifying licenses, refer to the *Managing License Keys* section of the *Software Management Operations* chapter in the *System Administration Guide*.

The following topics are included:

- [Feature Description, on page 1003](#)
- [Traffic Policing, on page 1003](#)
- [Traffic Shaping, on page 1004](#)
- [Traffic Policing Configuration, on page 1004](#)
- [Traffic Shaping Configuration, on page 1007](#)
- [Configuring Traffic Shaping, on page 1009](#)
- [RADIUS Attributes, on page 1012](#)

Feature Description

This section describes the traffic policing and traffic shaping for individual subscribers.

Traffic Policing

Traffic policing enables bandwidth limitations on individual subscribers and/or APN of a particular traffic class in 3GPP/3GPP2 service.

Bandwidth enforcement is configured and enforced independently on the downlink and the uplink directions.

The Traffic Policing feature uses the Token Bucket algorithm (a modified trTCM) as specified in RFC2698. The algorithm measures the following criteria to determine a packet:

- **Committed Data Rate (CDR):** The guaranteed rate (in bits per second) at which packets can be transmitted/received for the subscriber during the sampling interval.
- **Peak Data Rate (PDR):** The maximum rate (in bits per second) that subscriber packets can be transmitted/received for the subscriber during the sampling interval.
- **Burst-size:** The maximum number of bytes that can be transmitted/received for the subscriber during the sampling interval for both committed (CBS) and peak (PBS) rate conditions. This represents the maximum number of tokens that can be placed in the subscriber's "bucket". Committed burst size (CBS) equals the peak burst size (PBS) for each subscriber.

The system can be configured to take any of the following actions on packets that are determined to be in excess or in violation:

- **Drop:** The offending packet is discarded.
- **Transmit:** The offending packet is passed.
- **Lower the IP Precedence:** The packet's ToS bit is set to "0", thus downgrading it to Best Effort, prior to passing the packet. The packet's ToS bit was already set to "0", this action is equivalent to "Transmit".

Traffic Shaping

Traffic Shaping is a rate limiting method that provides a buffer facility for packets exceeded the configured limit. Once the packet that exceed the data rate, the packet queued inside the buffer to be delivered at a later time.

The bandwidth enforcement can be done in the downlink and uplink directions independently. If there is no more buffer space available for subscriber data the system can be configured to either drop the packets or transmit for the next scheduled traffic session.

Traffic Policing Configuration

Traffic Policing is configured on a per-subscriber basis. The subscribers can either be locally configured subscribers on the system or subscriber profiles configured on a remote RADIUS server.

In 3GPP service, traffic policing can be configured for subscribers through APN configuration as well.



Important

In 3GPP service, the attributes received from the RADIUS server supersede the settings in the APN.



Important

Commands used in the configuration samples in this section provide base functionality to the extent that the most common or likely commands and/or keyword options are presented. In many cases, other optional commands and/or keyword options are available. Refer to the *Command Line Interface Reference* for complete information regarding all commands.

Configuring Subscribers for Traffic Policing



Important Instructions for configuring RADIUS-based subscriber profiles are not provided in this document. Please refer to the documentation supplied with your server for further information.

Step 1 Configure local subscriber profiles on the system to support Traffic Policing by applying the following example configurations:

- a) To apply the specified limits and actions to the downlink (data to the subscriber):

```
configure
  context context_name
    subscriber name <user_name>
      qos traffic-police direction downlink
    end
```

- b) To apply the specified limits and actions to the uplink (data from the subscriber):

```
configure
  context context_name
    subscriber name <user_name>
      qos traffic-police direction uplink
    end
```

Notes:

- There are numerous keyword options associated with the **qos traffic-police direction { downlink | uplink }** command.
- Repeat for each additional subscriber to be configured.

Note If the exceed/violate action is set to "lower-ip-precedence", the TOS value for the outer packet becomes "best effort" for packets that exceed/violate the traffic limits regardless of what the **ip user-datagram-tos-copy** command in the Subscriber Configuration mode is configured to. In addition, the "lower-ip-precedence" option may also override the configuration of the **ip qos-dscp** command (also in the Subscriber Configuration mode). Therefore, it is recommended that command not be used when specifying this option.

Step 2 Verify the subscriber profile configuration by applying the following example configuration:

```
context <context_name>
  show subscriber configuration username <user_name>
```

Step 3 Save your configuration to flash memory, an external memory device, and/or a network location using the Exec mode command **save configuration**. For additional information on how to verify and save configuration files, refer to the *System Administration Guide* and the *Command Line Interface Reference*.

Configuring APN for Traffic Policing in 3GPP Networks

This section provides information and instructions for configuring the APN template's QoS profile in support of Traffic Policing.

The profile information is sent to the SGSN(s) in response to the GTP Create/Update PDP Context Request messages. If the QoS profile requested by the SGSN is lower than the configured QoS profile, the profile requested by the SGSN is used. If the QoS profile requested by the SGSN is higher, the configured rates are used.

The values for the committed data rate and peak data rate parameters are exchanged in the GTP messages between the GGSN and the SGSN. Therefore, the values used may be lower than the configured values. When negotiating the rate with the SGSN(s), the system converts this rate to a value that is permitted by GTP as shown in the following table:

Table 95: Permitted Values for Committed and Peak Data Rates in GTP Messages

Value (bps)	Increment Granularity (bps)
From 1000 to 63,000	1,000 (for example, 1000, 2000, 3000, ... 63000)
From 64,000 to 568,000	8,000 (for example, 64000, 72000, 80000, ... 568000)
From 576,000 to 8,640,000	64,000 (for example, 576000, 640000, 704000, ... 864000)
From 8,700,000 to 16,000,000	100,000 bps (for example, 8700000, 8800000, 8900000, 16000000)

Step 1 Set parameters by applying the following example configurations:

- a) To apply the specified limits and actions to the downlink (the Gn direction):

```
configure
  context <context_name>
    apn <apn_name>
      qos rate-limit downlink
    end
```

- b) To apply the specified limits and actions to the uplink (the Gi direction):

```
configure
  context <context_name>
    apn <apn_name>
      qos rate-limit uplink
    end
```

Notes:

- There are numerous keyword options associated with **qos rate-limit { downlink | uplink }** command.
- *Optionally*, configure the maximum number of PDP contexts that can be facilitated by the APN to limit the APN's bandwidth consumption by entering the following command in the configuration:

```
max-contents primary <number> total <total_number>
```

- Repeat as needed to configure additional QoS Traffic Policing profiles.

Important If a "subscribed" traffic class is received, the system changes the class to background and sets the following: The uplink and downlink guaranteed data rates are set to 0. If the received uplink or downlink data rates are 0 and traffic policing is disabled, the default of 64 kbps is used. When enabled, the APN configured values are used. If the configured value for downlink max data rate is larger than can fit in an R4 QoS profile, the default of 64 kbps is used. If either the received uplink or downlink max data rates is non-zero, traffic policing is employed if enabled for the background class. The received values are used for responses when traffic policing is disabled.

Step 2 Verify that your APNs were configured properly by entering the following command:

```
show apn { all | name apn_name }
```

The output is a concise listing of configured APN parameter settings.

Step 3 Save your configuration to flash memory, an external memory device, and/or a network location using the Exec mode command **save configuration**. For additional information on how to verify and save configuration files, refer to the *System Administration Guide* and the *Command Line Interface Reference*.

Traffic Shaping Configuration

Traffic Shaping is configured on a per-subscriber basis. The subscribers can either be locally configured subscribers on the system or subscriber profiles configured on a remote RADIUS server.

In 3GPP service Traffic policing can be configured for subscribers through APN configuration as well.



Important In 3GPP, service attributes received from the RADIUS server supersede the settings in the APN.



Important Commands used in the configuration samples in this section provide base functionality to the extent that the most common or likely commands and/or keyword options are presented. In many cases, other optional commands and/or keyword options are available. Refer to the *Command Line Interface Reference* for complete information regarding all commands.

Configuring Subscribers for Traffic Shaping

This section provides information and instructions for configuring local subscriber profiles on the system to support Traffic Shaping.



Important Instructions for configuring RADIUS-based subscriber profiles are not provided in this document. Please refer to the documentation supplied with your server for further information.

Step 1 Set parameters by applying the following example configurations:

a) To apply the specified limits and actions to the downlink (data to the subscriber):

```

configure
  context <context_name>
    subscriber name <user_name>
      qos traffic-shape direction downlink
    end

```

b) To apply the specified limits and actions to the uplink (data to the subscriber):

```

configure
  context <context_name>
    subscriber name <user_name>
      qos traffic-shape direction uplink
    end

```

Notes:

- There are numerous keyword options associated with **qos traffic-shape direction { downlink | uplink }** command.
- Repeat for each additional subscriber to be configured.

Important If the exceed/violate action is set to "lower-ip-precedence", the TOS value for the outer packet becomes "best effort" for packets that exceed/violate the traffic limits regardless of what the **ip user-datagram-tos-copy** command in the Subscriber Configuration mode is configured to. In addition, the "lower-ip-precedence" option may also override the configuration of the **ip qos-dscp** command (also in the Subscriber Configuration mode). Therefore, it is recommended that command not be used when specifying this option.

Step 2 Verify the subscriber profile configuration by applying the following example configuration:

```

context <context_name>
  show subscriber configuration username <user_name>

```

Step 3 Save your configuration to flash memory, an external memory device, and/or a network location using the Exec mode command **save configuration**. For additional information on how to verify and save configuration files, refer to the *System Administration Guide* and the *Command Line Interface Reference*.

Configuring APN for Traffic Shaping in 3GPP Networks

This section provides information and instructions for configuring the APN template's QoS profile in support of Traffic Shaping.

The profile information is sent to the SGSN(s) in response to the GTP Create/Update PDP Context Request messages. If the QoS profile requested by the SGSN is lower than the configured QoS profile, the profile requested by the SGSN is used. If the QoS profile requested by the SGSN is higher, the configured rates are used.

The values for the committed data rate and peak data rate parameters are exchanged in the GTP messages between the GGSN and the SGSN. Therefore, the values used may be lower than the configured values. When negotiating the rate with the SGSN(s), the system converts this rate to a value that is permitted by GTP as shown in the following table.

Table 96: Permitted Values for Committed and Peak Data Rates in GTP Messages

Value (bps)	Increment Granularity (bps)
From 1000 to 63,000	1,000 (for example, 1000, 2000, 3000, ... 63000)
From 64,000 to 568,000	8,000 (for example, 64000, 72000, 80000, ... 568000)
From 576,000 to 8,640,000	64,000 (for example, 576000, 640000, 704000, ... 8640000)
From 8,700,000 to 16,000,000	100,000 bps (for example, 8700000, 8800000, 8900000, ... 16000000)

Step 1 Set parameters by applying the following example configurations.

a) To apply the specified limits and actions to the downlink (data to the subscriber):

```
configure
  context context_name
    subscriber name user_name
      qos rate-limit downlink
    end
```

b) To apply the specified limits and actions to the uplink (data to the subscriber):

```
configure
  context context_name
    apn apn_name
      qos rate-limit uplink
    end
```

Step 2 Verify that your APNs were configured properly by entering the following command:

```
show apn { all | name apn_name }
```

The output is a concise listing of configured APN parameter settings.

Step 3 Save your configuration to flash memory, an external memory device, and/or a network location using the Exec mode command **save configuration**. For additional information on how to verify and save configuration files, refer to the *System Administration Guide* and the *Command Line Interface Reference*.

Configuring Traffic Shaping

Configuring Subscribers for Traffic Shaping

This section provides information and instructions for configuring local subscriber profiles on the system to support Traffic Shaping.



Important Instructions for configuring RADIUS-based subscriber profiles are not provided in this document. Please refer to the documentation supplied with your server for further information.

Step 1 Set parameters by applying the following example configurations:

a) To apply the specified limits and actions to the downlink (data to the subscriber):

```
configure
  context <context_name>
    subscriber name <user_name>
      qos traffic-shape direction downlink
    end
```

b) To apply the specified limits and actions to the uplink (data to the subscriber):

```
configure
  context <context_name>
    subscriber name <user_name>
      qos traffic-shape direction uplink
    end
```

Notes:

- There are numerous keyword options associated with **qos traffic-shape direction { downlink | uplink }** command.
- Repeat for each additional subscriber to be configured.

Important If the exceed/violate action is set to "lower-ip-precedence", the TOS value for the outer packet becomes "best effort" for packets that exceed/violate the traffic limits regardless of what the **ip user-datagram-tos-copy** command in the Subscriber Configuration mode is configured to. In addition, the "lower-ip-precedence" option may also override the configuration of the **ip qos-dscp** command (also in the Subscriber Configuration mode). Therefore, it is recommended that command not be used when specifying this option.

Step 2 Verify the subscriber profile configuration by applying the following example configuration:

```
context <context_name>
  show subscriber configuration username <user_name>
```

Step 3 Save your configuration to flash memory, an external memory device, and/or a network location using the Exec mode command **save configuration**. For additional information on how to verify and save configuration files, refer to the *System Administration Guide* and the *Command Line Interface Reference*.

Configuring APN for Traffic Shaping in 3GPP Networks

This section provides information and instructions for configuring the APN template's QoS profile in support of Traffic Shaping.

The profile information is sent to the SGSN(s) in response to the GTP Create/Update PDP Context Request messages. If the QoS profile requested by the SGSN is lower than the configured QoS profile, the profile requested by the SGSN is used. If the QoS profile requested by the SGSN is higher, the configured rates are used.

The values for the committed data rate and peak data rate parameters are exchanged in the GTP messages between the GGSN and the SGSN. Therefore, the values used may be lower than the configured values. When negotiating the rate with the SGSN(s), the system converts this rate to a value that is permitted by GTP as shown in the following table.

Table 97: Permitted Values for Committed and Peak Data Rates in GTP Messages

Value (bps)	Increment Granularity (bps)
From 1000 to 63,000	1,000 (for example, 1000, 2000, 3000, ... 63000)
From 64,000 to 568,000	8,000 (for example, 64000, 72000, 80000, ... 568000)
From 576,000 to 8,640,000	64,000 (for example, 576000, 640000, 704000, ... 8640000)
From 8,700,000 to 16,000,000	100,000 bps (for example, 8700000, 8800000, 8900000, ... 16000000)

Step 1 Set parameters by applying the following example configurations.

a) To apply the specified limits and actions to the downlink (data to the subscriber):

```
configure
  context context_name
    subscriber name user_name
      qos rate-limit downlink
    end
```

b) To apply the specified limits and actions to the uplink (data to the subscriber):

```
configure
  context context_name
    apn apn_name
      qos rate-limit uplink
    end
```

Step 2 Verify that your APNs were configured properly by entering the following command:

```
show apn { all | name apn_name }
```

The output is a concise listing of configured APN parameter settings.

Step 3 Save your configuration to flash memory, an external memory device, and/or a network location using the Exec mode command **save configuration**. For additional information on how to verify and save configuration files, refer to the *System Administration Guide* and the *Command Line Interface Reference*.

RADIUS Attributes

Traffic Policing for CDMA Subscribers

The RADIUS attributes listed in the following table configure Traffic Policing for CDMA subscribers (PDSN and HA) that are configured on remote RADIUS servers. See the *AAA Interface Administration and Reference* for more information on these attributes.

Table 98: RADIUS Attributes Required for Traffic Policing Support for CDMA Subscribers

Attribute	Description
SN-QoS-Tp-Dnlk (or SN1-QoS-Tp-Dnlk)	Enable or disable traffic policing in the downlink direction.
SN-Tp-Dnlk-Committed-Data-Rate (or SN1-Tp-Dnlk-Committed-Data-Rate)	Specifies the downlink committed data rate in bps.
SN-Tp-Dnlk-Peak-Data-Rate (or SN1-Tp-Dnlk-Committed-Data-Rate)	Specifies the downlink peak data rate in bps.
SN-Tp-Dnlk-Burst-Size (or SN1-Tp-Dnlk-Burst-Size)	Specifies the downlink-burst-size in bytes. NOTE: This parameter must be configured to the greater of the following two values: 1) 3 times greater than packet MTU for the subscriber connection, OR 2) 3 seconds worth of token accumulation within the "bucket" for the configured peak data rate.
SN-Tp-Dnlk-Exceed-Action (or SN1-Tp-Dnlk-Exceed-Action)	Specifies the downlink exceed action to perform.
SN-Tp-Dnlk-Violate-Action (or SN1-Tp-Dnlk-Violate-Action)	Specifies the downlink violate action to perform.
SN-QoS-Tp-Uplk (or SN1-QoS-Tp-Uplk)	Enable/disable traffic policing in the downlink direction.
SN-Tp-Uplk-Committed-Data-Rate (or SN1-Tp-Uplk-Committed-Data-Rate)	Specifies the uplink committed data rate in bps.
SN-Tp-Uplk-Peak-Data-Rate (or SN1-Tp-Uplk-Committed-Data-Rate)	Specifies the uplink peak data rate in bps.

Attribute	Description
SN-Tp-Uplk-Burst-Size (or SN1-Tp-Uplk-Burst-Size)	Specifies the uplink burst size in bytes. Note This parameter must be configured to at least the greater of the following two values: 1) 3 times greater than the packet MTU for the subscriber connection, OR 2) 10 seconds worth of token accumulation within the "bucket" for the configured peak data rate.
SN-Tp-Uplk-Exceed-Action (or SN1-Tp-Uplk-Exceed-Action)	Specifies the uplink exceed action to perform.
SN-Tp-Uplk-Violate-Action (or SN1-Tp-Uplk-Violate-Action)	Specifies the uplink violate action to perform.

Traffic Policing for UMTS Subscribers

The RADIUS attributes listed in the following table are used to configure Traffic Policing for UMTS subscribers configured on remote RADIUS servers. More information on these attributes can be found in the *AAA Interface Administration and Reference*.

Table 99: RADIUS Attributes Required for Traffic Policing Support for UMTS Subscribers

Attribute	Description
SN-QoS-Conversation-Class (or SN1-QoS-Conversation-Class)	Specifies the QoS Conversation Traffic Class.
SN-QoS-Streaming-Class (or SN1-QoS-Streaming-Class)	Specifies the QoS Streaming Traffic Class.
SN-QoS-Interactive1-Class (or SN1-QoS-Interactive1-Class)	Specifies the QoS Interactive Traffic Class.
SN-QoS-Interactive2-Class (or SN1-QoS-Interactive2-Class)	Specifies the QoS Interactive2 Traffic Class.
SN-QoS-Interactive3-Class (or SN1-QoS-Interactive3-Class)	Specifies the QoS Interactive3 Traffic Class.
SN-QoS-Background-Class (or SN1-QoS-Background-Class)	Specifies the QoS Background Traffic Class.

Attribute	Description
SN-QoS-Traffic-Policy (or SN1-QoS-Traffic-Policy)	<p>This compound attribute simplifies sending QoS values for Traffic Class (the above attributes), Direction, Burst-Size, Committed-Data-Rate, Peak-Data-Rate, Exceed-Action, and Violate-Action from the RADIUS server.</p> <p>This attribute can be sent multiple times for different traffic classes. If Class is set to 0, it applies across all traffic classes.</p>



CHAPTER 61

Type of Service/Traffic Class Configuration for Predefined Rules

- [Feature Summary and Revision History, on page 1015](#)
- [Feature Description, on page 1016](#)
- [How It Works, on page 1016](#)
- [Configuring the TOS/Traffic Class for Predefined Rules , on page 1017](#)
- [Monitoring and Troubleshooting, on page 1018](#)

Feature Summary and Revision History

Summary Data

Applicable Product(s) and Functional Area	<ul style="list-style-type: none"> • GGSN • P-GW • SAEGW
Applicable Platform(s)	<ul style="list-style-type: none"> • ASR 5500 • VPC - DI • VPC - SI
Feature Default	Disabled - Configuration Required
Related Changes in This Release	Not Applicable
Related Documentation	<ul style="list-style-type: none"> • <i>Command Line Interface Reference</i> • <i>GGSN Administration Guide</i> • <i>P-GW Administration Guide</i> • <i>SAEGW Administration Guide</i>

Revision History

Revision Details	Release
First Introduced	21.3

Feature Description

A traffic flow template (TFT) is an information element that specifies parameters and operations for a Packet Data Protocol (PDP) context. This information element may be used to transfer extra parameters to the network (for example, the Authorization Token; see 3GPP TS 24.229 [95]). The TFT may contain packet filters for the downlink direction, uplink direction, or for both directions.

The packet filters determine the traffic mapping to PDP contexts. Ideally, the network uses the downlink packet filters while the mobile stations use the uplink packet filters. This behavior is also seen for a packet filter that applies to both the directions.

The TFT is a type 4 information element with a minimum length of 3 octets. The maximum length for the IE is 257 octets.

Currently, there is a requirement for an Operator to identify and filter data traffic based on the "Type of Service (TOS)/Traffic class" information. This information needs to be configured as part of the Predefined or Dynamic rules (or both). Also, the Operator wants to send "Type of Service (TOS)/Traffic Class" information as part of TFT in the Create Bearer Request (CBR) and Update Bearer Request (UBR) messages, which can be triggered via the Local Policy or PCRF.

For Dynamic rules, the P-GW already supports "Type of Service (TOS)/Traffic class" information that is used to identify specific data traffic. However, for Predefined rules, there is no option available to configure "Type of Service(TOS)/Traffic class" information as part of packet filter configuration.

This feature introduces the **ip tos-traffic-class** CLI to configure Type of Service (TOS)/Traffic class information in the packet filter configured under charging action to address the Operator requirements.

How It Works

The new CLI configures the packet filter associated with the Predefined rules, with the "Type of Service (TOS)/Traffic Class" configuration. These Predefined rules can be triggered via Local Policy or as part of PCRF communication.

The CLI syntax to configure "Type of Service (TOS)/Traffic Class" information under Predefined rules is in-line with "Type of Service (TOS)/Traffic Class" AVP information that is received as part of the Dynamic rules from PCRF.

According to 3GPPP 24.008 - Section 10.5.6.12, "For "Type of service/Traffic class type", the packet filter component value field shall be encoded as a sequence of a one octet Type-of-Service/Traffic Class field and a one octet Type-of-Service/Traffic Class mask field. The Type-of-Service/Traffic Class field shall be transmitted first."

For example:

```
toS/traffic class: 0x20 0xff
```

Also, now the P-GW includes both the "Type of Service (TOS)/Traffic class" information under TFT IE, as part of the Create Bearer Request (CBR) and Update Bearer Request (UBR) messages (which is in line with 3GPP 29.212 Section 5.3.14).



Important

- The CLI is added in “packet-filter” configuration mode to configure TOS/Traffic class information.
- While triggering the Create or Update Bearer Request towards a peer, P-GW populates the "Type of Service (TOS)/Traffic class" information under TFT IE if the Predefined rule associated with that bearer is configured with "Type of Service (TOS)/Traffic class" information.
- There is no impact of Session Manager Recovery or ICSR on existing bearer packet filter information.

Limitations

Following are the limitations of this feature:

- Operator should configure TOS along with mask and there are no default values for TOS value and mask.
- For any change of "Type of Service (TOS)/Traffic class" configuration under packet filter, the behavior is in line with the other packet filter parameter configuration change.
- Current PGW/GGSN/SAEGW behavior is that if the Predefined rules installed on the different bearers have ToS/Traffic class configured for uplink traffic on one bearer and downlink traffic on another bearer, then uplink and downlink packets for the same flow go through different bearers accordingly. However, if these Predefined rules with configured ToS/Traffic class are removed on the fly, still uplink and downlink packets for the same flow will go through different bearers.
- Consider the scenario where there are two dedicated bearers installed with Predefined rules such that the uplink traffic with a particular ToS/Traffic class say t1, matches first dedicated bearer and the downlink traffic with another ToS/Traffic class say t2, matches downlink traffic. If the IP ToS/Traffic class CLI is disabled in the corresponding Predefined rules followed by SESSMGR restart, the downlink packets with ToS/Traffic class "t2" will go through the first dedicated bearer instead of second if there is an uplink packet with the same flow (source IP, source port, destination IP, destination port) received before this downlink packet.

Configuring the TOS/Traffic Class for Predefined Rules

The following section provides the configuration command to enable or disable the feature.

Enabling or Disabling the ip tos-traffic-class Command

The modified command, **ip tos-traffic-class**, is used to configure ToS/Traffic class under charging action in the Packet filter mode.

This CLI is disabled by default.

To enable or disable the feature, enter the following commands:

```

configure
  active-charging service service_name
    packet-filter packet_filter
      [ no ] ip tos-traffic-class { type_of_service | traffic class } mask
      { mask_value }
    end

```

Notes:

- **no** : If previously configured, deletes the ToS/Traffic class under charging action.
- **tos-traffic-class** = { *type_of_service* | *traffic class* } : Specifies the Type of Service (TOS)/Traffic Class" value that is used to filter the traffic. Enter an integer, ranging from 0 to 255.
- **mask** { *mask_value* } : Validates the dynamic rules for automatic recovery after a switchover. Enter an integer, ranging from 0 to 255.

Monitoring and Troubleshooting

This section provides information regarding show commands and/or their outputs in support of this feature.

Show Commands

This section lists all the show commands available to monitor this feature.

show configuration

This command has been modified to display the following output:

```

show configuration
configure
  active-charging service acs
  packet-filter PF226
    ip protocol = 6
    ip remote-port = 226
    ip tos-traffic-class = 32 mask = 255
  exit

```

show active-charging packet-filter

This command has been modified to display the following output:

When ToS/Traffic class is enabled/configured:

```

show active-charging packet-filter { all | name }
Service Name: acs

Packet Filter Name: abcd
  IP Proto: 6
  Local Port: Not configured
  Remote Port: 226
  Remote IP Address: Not configured
  Direction: Bi-Directional
  Priority: None

```

```
Tos-traffic-class: 32
Tos-traffic-class-mask: 255
```

When ToS/Traffic class is disabled/not configured:

```
show active-charging packet-filter { all | name }
```

```
Service Name: acs
```

```
Packet Filter Name: abcd
  IP Proto: 6
  Local Port: Not configured
  Remote Port: 226
  Remote IP Address: Not configured
  Direction: Bi-Directional
  Priority: None
Tos-traffic-class: Not configured
Tos-traffic-class-mask: Not configured
```

show configuration verbose

This command has been modified to display the following output:

When ToS/Traffic class is enabled/configured:

```
show configuration verbose
configure
  active-charging service acs
  packet-filter PF226
    ip protocol = 6
    ip remote-port = 226
    ip tos-traffic-class = 32 mask = 255
  ---
  exit
```

When ToS/Traffic class is disabled/not configured:

```
show configuration verbose
configure
  active-charging service acs
  packet-filter PF226
    ip protocol = 6
    ip remote-port = 226
    no ip tos-traffic-class
  ---
  exit
```

show configuration verbose



APPENDIX **A**

S-GW Engineering Rules

This appendix provides Serving Gateway-specific engineering rules or guidelines that must be considered prior to configuring the ASR 5500 for your network deployment. General and network-specific rules are located in the appendix of the *System Administration Guide* for the specific network type.

The following rules are covered:

- [Interface and Port Rules, on page 1021](#)
- [S-GW Service Rules, on page 1022](#)
- [S-GW Subscriber Rules, on page 1023](#)

Interface and Port Rules

The assumptions and rules discussed in this section pertain to Ethernet line cards and the type of interfaces they facilitate.

Assumptions

Overall assumptions for the S5/S8 and S11 interfaces used in the LTE EPC between Serving Gateway and PDN-GW are listed below.

- GTPv2-C is the signaling protocol used on the S5/S8 and S11 interfaces. Message and IE definitions comply with 3GPP 29.274.
- S5 and S11 interfaces use IPv6 transport as defined in 29.274, section 10.
- MSISDN is assumed to be sent by MME in initial attach.
- MEI will always be retrieved by MME from UE and sent on S11 during initial attach and UE Requested PDN connectivity procedure.
- MME will always send UE time zone information.
- The default bearer does not require any TFT.
- The PCO IE in Create Session Request shall contain two DNS server IP addresses. [S5/S8]
- UE's location change reporting support is required. [S5/S8]
- The S-GW does not verify the content of the IEs which are forwarded on the S5/S8 interface from the S11 interface. The P-GW verifies the content of all the IEs received on the S5/S8 interface.

S1-U/S11 Interface Rules

The following engineering rules apply to the S1-U0/S11 interface:

- An S1-U/S11 interface is created once the IP address of a logical interface is bound to an S-GW service. The S-GW supports a maximum of one million S1-U peers.
- The logical interface(s) that will be used to facilitate the S1-U0/S11 interface(s) must be configured within an "ingress" context.
- S-GW services must be configured within an "ingress" context.
- At least one S-GW service must be bound to each interface, however, multiple S-GW services can be bound to a single interface if secondary addresses are assigned to the interface.
- Depending on the services offered to the subscriber, the number of sessions facilitated by the S1-U0/S11 interface can be limited.

S5/S8 Interface Rules

This section describes the engineering rules for the S5 interface for communications between the Mobility Access Gateway (MAG) service residing on the S-GW and the Local Mobility Anchor (LMA) service residing on the P-GW.

MAG to LMA Rules

The following engineering rules apply to the S5/S8 interface from the MAG service to the LMA service residing on the P-GW:

- An S5/S8 interface is created once the IP address of a logical interface is bound to an MAG service.
- The logical interface(s) that will be used to facilitate the S5/S8 interface(s) must be configured within the egress context.
- MAG services must be configured within the egress context.
- MAG services must be associated with an S-GW service.
- Depending on the services offered to the subscriber, the number of sessions facilitated by the S5/S8 interface can be limited.

S-GW Service Rules

The following engineering rules apply to services configured within the system:

- A maximum of 256 services (regardless of type) can be configured per system.



Caution

Large numbers of services greatly increase the complexity of management and may impact overall system performance. Only create a large number of services only be configured if your application absolutely requires it. Please contact your local service representative for more information.

- The system maintains statistics for a maximum of 4,096 peer LMAs per MAG service.
- The total number of entries per table and per chassis is limited to 256.
- Even though service names can be identical to those configured in different contexts on the same system, this is not a good practice. Having services with the same name can lead to confusion, difficulty troubleshooting problems, and make it difficult to understand outputs of **show** commands.

S-GW Subscriber Rules

The following engineering rule applies to subscribers configured within the system:

- A maximum of 2,048 local subscribers can be configured per context.
- Default subscriber templates may be configured on a per S-GW or MAG service.



APPENDIX **B**

P-GW Engineering Rules

This appendix provides PDN Gateway-specific engineering rules or guidelines that must be considered prior to configuring the ASR 5500 for your network deployment. General and network-specific rules are located in the appendix of the *System Administration and Configuration Guide* for the specific network type.

The following topics are included:

- [Interface and Port Rules, on page 1025](#)
- [P-GW Context and Service Rules, on page 1026](#)
- [P-GW Subscriber Rules, on page 1026](#)

Interface and Port Rules

The rules discussed in this section pertain to the Ethernet 10/100 line card, the Ethernet 1000 line card and the four-port Quad Gig-E line card and the type of interfaces they facilitate, regardless of the application.

S2a Interface Rules

This section describes the engineering rules for the S2a interface for communications between the Mobility Access Gateway (MAG) service residing on the HSGW and the Local Mobility Anchor (LMA) service residing on the P-GW.

LMA to MAG

The following engineering rules apply to the S2a interface from the LMA service to the MAG service residing on the HSGW:

- An S2a interface is created once the IP address of a logical interface is bound to an LMA service.
- The logical interface(s) that will be used to facilitate the S2a interface(s) must be configured within an ingress context.
- LMA services must be configured within an ingress context.
- Depending on the services offered to the subscriber, the number of sessions facilitated by the S2a interface can be limited in order to allow higher bandwidth per subscriber.

S5/S8 Interface Rules (GTP)

The following engineering rule applies to the S5/S8 interface from the P-GW to the S-GW:

- P-GW preserves an IP address between S2a interface (PMIPv6) and S5/S8 interface (GTP) when the user moves between Wi-Fi and LTE if a common P-GW is used as the anchor point between the two services.

P-GW Context and Service Rules

The following engineering rules apply to services configured within the system:

- A maximum of 256 services (regardless of type) can be configured per system.



Caution

Large numbers of services greatly increase the complexity of management and may impact overall system performance (i.e. resulting from such things as system handoffs). Therefore, it is recommended that a large number of services only be configured if your application absolutely requires it. Please contact your local service representative for more information.

- The system supports unlimited peer HSGW/MAG addresses per P-GW.
 - The system maintains statistics for a maximum of 8192 peer HSGWs per P-GW service.
 - If more than 8192 HSGWs are attached, older statistics are identified and overwritten.
 - PMIPv6 does not support any peer level statistics (per MAG level statistics).
- The system supports 65,000 S-GW addresses per P-GW.
 - The system maintains statistics for all peer S-GWs per P-GW service.
- The system maintains statistics for a maximum of 64,000 peer P-GWs per HSGW or S-GW service.
- There are a maximum of 8 P-GW assignment tables per context and per chassis.
- The total number of entries per table and per chassis is limited to 256.

P-GW Subscriber Rules

The following engineering rule applies to subscribers configured within the system:

- Default subscriber templates may be configured on a per P-GW service.