



## **ASR 5500 Installation Guide**

**First Published:** 2016-07-14

**Last Modified:** 2017-04-27

### **Americas Headquarters**

Cisco Systems, Inc.  
170 West Tasman Drive  
San Jose, CA 95134-1706  
USA  
<http://www.cisco.com>  
Tel: 408 526-4000  
800 553-NETS (6387)  
Fax: 408 527-0883

THE SPECIFICATIONS AND INFORMATION REGARDING THE PRODUCTS IN THIS MANUAL ARE SUBJECT TO CHANGE WITHOUT NOTICE. ALL STATEMENTS, INFORMATION, AND RECOMMENDATIONS IN THIS MANUAL ARE BELIEVED TO BE ACCURATE BUT ARE PRESENTED WITHOUT WARRANTY OF ANY KIND, EXPRESS OR IMPLIED. USERS MUST TAKE FULL RESPONSIBILITY FOR THEIR APPLICATION OF ANY PRODUCTS.

THE SOFTWARE LICENSE AND LIMITED WARRANTY FOR THE ACCOMPANYING PRODUCT ARE SET FORTH IN THE INFORMATION PACKET THAT SHIPPED WITH THE PRODUCT AND ARE INCORPORATED HEREIN BY THIS REFERENCE. IF YOU ARE UNABLE TO LOCATE THE SOFTWARE LICENSE OR LIMITED WARRANTY, CONTACT YOUR CISCO REPRESENTATIVE FOR A COPY.

The following information is for FCC compliance of Class A devices: This equipment has been tested and found to comply with the limits for a Class A digital device, pursuant to part 15 of the FCC rules. These limits are designed to provide reasonable protection against harmful interference when the equipment is operated in a commercial environment. This equipment generates, uses, and can radiate radio-frequency energy and, if not installed and used in accordance with the instruction manual, may cause harmful interference to radio communications. Operation of this equipment in a residential area is likely to cause harmful interference, in which case users will be required to correct the interference at their own expense.

The following information is for FCC compliance of Class B devices: This equipment has been tested and found to comply with the limits for a Class B digital device, pursuant to part 15 of the FCC rules. These limits are designed to provide reasonable protection against harmful interference in a residential installation. This equipment generates, uses and can radiate radio frequency energy and, if not installed and used in accordance with the instructions, may cause harmful interference to radio communications. However, there is no guarantee that interference will not occur in a particular installation. If the equipment causes interference to radio or television reception, which can be determined by turning the equipment off and on, users are encouraged to try to correct the interference by using one or more of the following measures:

- Reorient or relocate the receiving antenna.
- Increase the separation between the equipment and receiver.
- Connect the equipment into an outlet on a circuit different from that to which the receiver is connected.
- Consult the dealer or an experienced radio/TV technician for help.

Modifications to this product not authorized by Cisco could void the FCC approval and negate your authority to operate the product

The Cisco implementation of TCP header compression is an adaptation of a program developed by the University of California, Berkeley (UCB) as part of UCB's public domain version of the UNIX operating system. All rights reserved. Copyright © 1981, Regents of the University of California.

NOTWITHSTANDING ANY OTHER WARRANTY HEREIN, ALL DOCUMENT FILES AND SOFTWARE OF THESE SUPPLIERS ARE PROVIDED "AS IS" WITH ALL FAULTS. CISCO AND THE ABOVE-NAMED SUPPLIERS DISCLAIM ALL WARRANTIES, EXPRESSED OR IMPLIED, INCLUDING, WITHOUT LIMITATION, THOSE OF MERCHANTABILITY, FITNESS FOR A PARTICULAR PURPOSE AND NONINFRINGEMENT OR ARISING FROM A COURSE OF DEALING, USAGE, OR TRADE PRACTICE.

IN NO EVENT SHALL CISCO OR ITS SUPPLIERS BE LIABLE FOR ANY INDIRECT, SPECIAL, CONSEQUENTIAL, OR INCIDENTAL DAMAGES, INCLUDING, WITHOUT LIMITATION, LOST PROFITS OR LOSS OR DAMAGE TO DATA ARISING OUT OF THE USE OR INABILITY TO USE THIS MANUAL, EVEN IF CISCO OR ITS SUPPLIERS HAVE BEEN ADVISED OF THE POSSIBILITY OF SUCH DAMAGES.

Any Internet Protocol (IP) addresses and phone numbers used in this document are not intended to be actual addresses and phone numbers. Any examples, command display output, network topology diagrams, and other figures included in the document are shown for illustrative purposes only. Any use of actual IP addresses or phone numbers in illustrative content is unintentional and coincidental.

Cisco and the Cisco logo are trademarks or registered trademarks of Cisco and/or its affiliates in the U.S. and other countries. To view a list of Cisco trademarks, go to this URL: <http://www.cisco.com/go/trademarks>. Third-party trademarks mentioned are the property of their respective owners. The use of the word partner does not imply a partnership relationship between Cisco and any other company. (1110R)

© 2017 Cisco Systems, Inc. All rights reserved.



## CONTENTS

---

### Preface

#### About this Guide **xiii**

Conventions Used **xiii**

Dimensions **xiv**

MIOs and DPCs **xiv**

Related Documentation **xv**

Contacting Customer Support **xv**

---

### CHAPTER 1

#### ASR 5500 Hardware Platform Overview **1**

Chassis **2**

Power **3**

Cooling **3**

Slot Numbering **4**

Power Filter Units (PFUs) **4**

Cable Management System **5**

Midplane **5**

Card Types **6**

Rear Cards **9**

Management I/O **9**

Data Processing Card **10**

Data Processing Card version 2 **10**

Front Cards **11**

Fabric and Storage Card (FSC) **11**

System Status Card (SSC) **12**

LED Indicators **12**

LED Indicators Common to All Cards **13**

LED Indicators on Specific Cards **13**

---

**CHAPTER 2**

**Technical Specifications 15**

- Physical Dimensions 15
- Environmental Specifications 16
  - Environmental Parameters 16
  - Environmental Standards 17
  - Chassis Air Flow 18
  - Clearance 19
- Mounting Requirements 20
- Power Requirements 21
  - Power Specifications 21
  - Example Power Calculations 22
    - DPC/UPDC Full Chassis 22
    - DPC2/UDPC2 Full Chassis 22
- Central Office Alarm Interface 23
- Chassis Grounding 23

---

**CHAPTER 3**

**Installation Procedure Overview 25**

- Installation Sequence 25
- Required Tools and Equipment 26
  - Hand Tools 26
  - Equipment 27
- Site Prerequisites 27
  - Power and Grounding 27
  - Environment 27
  - Clearance 28
- ESD Precautions 28
- Standards Compliance 29
  - FCC Warning 29
  - ICS Notice 30
  - Laser Notice 30

---

**CHAPTER 4**

**Chassis Installation 31**

- Mounting Options 31
- Weight Considerations 32

Unpacking the Chassis	32
Move the Container to the Installation Site	32
Unpack the Chassis	33
Reducing the Weight of the Chassis Prior to Installation	35
Removing the Fan Trays	35
Remove the Upper Front Fan Tray	36
Remove the Lower Front Fan Tray	37
Remove the Upper Rear Fan Tray	37
Remove the Lower Rear Fan Tray	37
Removing the PFUs	39
Installing the Chassis	40
Mounting the Chassis	40
Flush Mount	40
Mid Mount	42
Grounding the Chassis	43
Ground Cabling	43
Grounding Procedure	45
Re-Installing Chassis Components	45
Re-install the PFUs	45
Re-install the Front Fan Trays	46
Lower Front Fan Tray	46
Upper Front Fan Tray	46
Re-install the Rear Fan Trays	46
Lower Rear Fan Tray	46
Upper Rear Fan Tray	47
Re-install the Chassis Cover Panels	47
Front of Chassis	47
Rear of Chassis	47
Cable Management System	47

---

**CHAPTER 5**

<b>Card Installation</b>	<b>49</b>
Card Slot Assignments	49
General Installation Sequence	51
Card Interlock Switch	52
Circuit Cards	53

Prerequisites	54
Installing Circuit Cards	54
Baffles	55
Installing a Front Baffle	57
Installing a Rear Baffle	57
Save Shipping Cartons	57

---

**CHAPTER 6****MIO Port Cabling 59**

Interface Ports	59
Front Panel Ports	59
Daughter Card Ports	60
Port Status LEDs	61
Cable Management System	62
Console Port	62
RJ45 Port Pinouts	62
RJ45 to DB9 Adapter	63
USB to DB9 Adapter	64
Connect Console Port to Workstation	65
Connect Console Port to Terminal Server	65
Ethernet Management STP Ports	66
RJ45 Port Pinouts	67
Connect 1000Base-T Interface to Network Device	67
10 GbE Optical Daughter Card Ports	67
Fiber Optic Bend Radius Guidelines	68
Recommended Bend Radius	68
Bend-Insensitive Multimode Fiber	69
Fiber Optical Connections	70
Removing Dust Plugs	70
Connecting Fiber Optic Cables	70
Cleaning Fiber Optic Connectors	71

---

**CHAPTER 7****SSC Alarm Cabling 73**

CO Alarm Interface	73
Alarm Cutoff (ACO)	74
Alarm Connector Pinout	75

Electrical Characteristics	75
CO Alarm Wiring Example	76

---

**CHAPTER 8****Power Cabling 77**

Power Considerations	77
Internal Power Planes	78
Chassis Power Card Slot Allocations	79
Power Feed Connections	80
Power Cable Requirements	81
Sizing Power Cables	81
Terminating Power Cables	82
Cable Routing	82
Method of Connection	82
Insulate Lugs	82
Crimp Lugs on Cables	82
Label All Cables	82
Connect Power Feeds to the PFUs	83

---

**CHAPTER 9****System Power-up 87**

System Boot Process	87
Applying Power to the Chassis	88
Verifying System Startup	89
Checking PFU Status	89
Checking Status LEDs on MIOs	89
Checking Status LEDs on Data Processing Cards	92
Checking Status LEDs on FSCs	93
Checking Status LEDs on SSC	94
show leds Command	95

---

**CHAPTER 10****Initial System Configuration 97**

Basic Configuration	97
Context-level Security Administrator and Hostname	98
MIO/UMIO Port Numbering	99
Configure the Ethernet Management Interface	100
IP Address Notation	100

IPv4 Dotted-Decimal Notation	100
IPv6 Colon-Separated-Hexadecimal Notation	101
CIDR Notation	101
Configuring the Ethernet Management Interface	102
Configuring the Management Interface with a Second IP Address	104
Configure the System for Remote Access	104
Configuring SSH Options	106
Setting SSH Key Size	106
Generating SSH Keys	107
Setting SSH Key Pair	107
Specifying SSH Encryption Ciphers	108
Set System Timing	109
Setting the System Clock and Time Zone	109
Configuring Network Time Protocol Support	109
Overview of NTP Support	109
Basic NTP Configuration	110
Configuring NTP Servers with Local Sources	110
Using a Load Balancer	111
Verifying the NTP Configuration	111
Enable CLI Timestamping	112
Save the Basic Configuration	112
Additional Configuration Tasks	112

---

**CHAPTER 11**

<b>System Monitoring</b>	<b>115</b>
Monitoring	115
Daily - Standard Health Check	115
Periodic Status Checks	117
Counters and Bulkstats	118
Summary of Maintenance Tasks	119
Constant Attention	119
Daily	119
Weekly	119
Monthly	120
6 Months	120
No Specific Time Frame	120



---

**CHAPTER 12****Replaceable Components 121**

## Air Filters 121

Determining When an Air Filter Needs Replacing 121

High Operating Temperatures and Fan Speeds 121

Temperature and Fan Alarm Commands 122

show fans Command 122

show temperature Command 122

Replacing an Air Filter 122

Front Air Filter 123

Rear Air Filter 125

## Fan Tray Units 127

Determining Whether a Fan Tray Unit Needs Replacing 127

Replacing Front Fan Trays 127

Replace the Upper Fan Tray 129

Replace the Lower Fan Tray 131

Replacing Rear Fan Trays 131

Replace the Upper Fan Tray 132

Replace the Lower Fan Tray 133

## PFU 135

Determining that a PFU has Failed 135

Replacing a PFU 135

## Circuit Cards 137

Determining Whether a Card has Failed 138

show card diag Command 138

SNMP Traps 139

Replacing Universal Cards 139

Backing Up the System Configuration 140

Synchronize File System 140

Preparing a Card for Replacement 140

Replacing a Failed Card 141

Remove I/O Connections (MIO/UMIO and SSC) 142

MIO or UMIO 142

SSC 142

Remove and Replace the Circuit Card 142

Swapping the SDHC Memory Card	144
Cleaning Fiber Optic Connectors	146
Returning Failed Components	147

---

**APPENDIX A**

<b>Spare Component Recommendations</b>	<b>149</b>
Spare Component Recommendations	149

---

**APPENDIX B**

<b>Chassis Universal License Requirements</b>	<b>151</b>
License Types	151
StarOS License Support Matrices	152
Updating A Chassis License for Universal Cards	153

---

**APPENDIX C**

<b>Cable Management System Installation</b>	<b>155</b>
Introduction	155
Installing the Cable Management Tray	155
Removing Cable Guides	159
Installing Cable Management Brackets	160
MIO/UMIO Cards	160
Securing Cables	162
Routing and Securing Network Cables	162
CMS Procedure for Replacing ASR 5500 Circuit Cards	164
Lowering the Cable Management Tray	165
Detaching Network Cables from the Card Bracket	165
Reconnecting Network Cables to the Card Bracket	165
Raising the Cable Management Tray	166

---

**APPENDIX D**

<b>Console Port to Cisco Server Cabling</b>	<b>167</b>
Introduction	167
Cabling	168
Configuration	169

---

**APPENDIX E**

<b>RMA Shipping Procedures</b>	<b>171</b>
RMA Overview	171
Re-packaging Your RMA	172
Shipping Multiple Components	172

Sealing the Shipment **172**  
Labeling the Shipment **172**  
Cisco Return Locations **173**  
Packaging ASR 5500 Cards **173**  
    Front Cards **173**  
    Rear Cards **174**





## About this Guide

---

This Installation Guide pertains to the features and functionality that run on and/or are associated with the Cisco® ASR 5500 platform.

It describes how to unpack, install and initially configure the system. This guide also includes technical specifications and guidelines for monitoring system operation.

- [Conventions Used, page xiii](#)
- [Dimensions, page xiv](#)
- [MIOs and DPCs, page xiv](#)
- [Related Documentation, page xv](#)
- [Contacting Customer Support, page xv](#)

## Conventions Used

The following tables describe the conventions used throughout this documentation.

Notice Type	Description
Information Note	Provides information about important features or instructions.
Caution	Alerts you of potential damage to a program, device, or system.
Warning	Alerts you of potential personal injury or fatality. May also alert you of potential electrical hazards.

Typeface Conventions	Description
Text represented as a screen display	This typeface represents displays that appear on your terminal screen, for example:  Login:

Typeface Conventions	Description
Text represented as <b>commands</b>	This typeface represents commands that you enter, for example: <b>show ip access-list</b> This document always gives the full form of a command in lowercase letters. Commands are not case sensitive.
Text represented as a <b>command variable</b>	This typeface represents a variable that is part of a command, for example: <b>show card slot_number</b> <i>slot_number</i> is a variable representing the desired chassis slot number.
Text represented as menu or sub-menu names	This typeface represents menus and sub-menus that you access within a software application, for example: Click the <b>File</b> menu, then click <b>New</b>

## Dimensions

Dimensions such as size, weight and temperature are first presented in their primary measurements (imperial or metric) followed by the converted measurement (metric or imperial) in parentheses.

## MIOs and DPCs

The ASR 5500 supports a variety of Management Input/Output and Data Processing Card types.

The currently supported Management Input/Output card types include:

- Management Input/Output (MIO)
- Universal Management Input/Output (UMIO)

MIO and UMIO card types differ only by the UMIO requirement for a Universal chassis license.

The currently supported Data Processing Card types include:

- Data Processing Card (DPC)
- Universal Data Processing Card (UDPC)
- Data Processing Card version 2 (DPC2)
- Universal Data Processing Card version 2 (UDPC2)

DPC and UDPC card types differ only by the UDPC requirement for a Universal chassis license. DPC2 and UDPC2 card types differ only by the UDPC2 requirement for a Universal chassis license. The DPC2/UDPC2 is only supported on ASR 5500 running StarOS release 18.2+.

When reference is made to an MIO card or DPC in this guide, it is presumed to apply to all types of these cards as identified above.

## Related Documentation

The most up-to-date information for this product is available in the product *Release Notes* provided with each product release.

The following documents are available on [www.cisco.com](http://www.cisco.com):

- *ASR 5500 Installation Guide*
- *Command Line Interface Reference*
- *SNMP MIB Reference*
- *Statistics and Counters Reference*
- *Thresholding Configuration Guide*
- Product-specific and feature-specific Administration guides

## Contacting Customer Support

Use the information in this section to contact customer support.

Refer to the support area of <http://www.cisco.com> for up-to-date product documentation or to submit a service request. A valid username and password are required to access this site. Please contact your Cisco sales or service representative for additional information.







## CHAPTER

# 1

## ASR 5500 Hardware Platform Overview

This chapter describes the hardware components that comprise the ASR 5500 chassis. The ASR 5500 is designed to provide subscriber management services for high-capacity 4G wireless networks.

*Figure 1: The ASR 5500*



This chapter includes the following sections:

- [Chassis, page 2](#)

- [Midplane, page 5](#)
- [Card Types, page 6](#)
- [LED Indicators, page 12](#)

## Chassis

The ASR 5500 is a 21RU, 19" rack-mount midplane-based chassis with input/output (I/O) and processing cards in the rear, and fabric cards in the front. Two ASR 5500 chassis fit into 42RU of rack space. However, the typical deployment will be a single chassis per rack with other equipment in the same rack.

The rear cards are larger and used for chassis management, I/O and session processing. The smaller front cards are used for fabric crossbars and persistent storage. There are 10 slots at the front and rear of the chassis.

The rear slots have a common midplane connector that is shared between the supported cards. This allows for different mixes of I/O and processing capacity depending on the customer's intended use.

The chassis can be flush-mounted or mid-mounted in a rack or equipment cabinet.

**Figure 2: Front and Rear Views of the ASR 5500 Chassis**

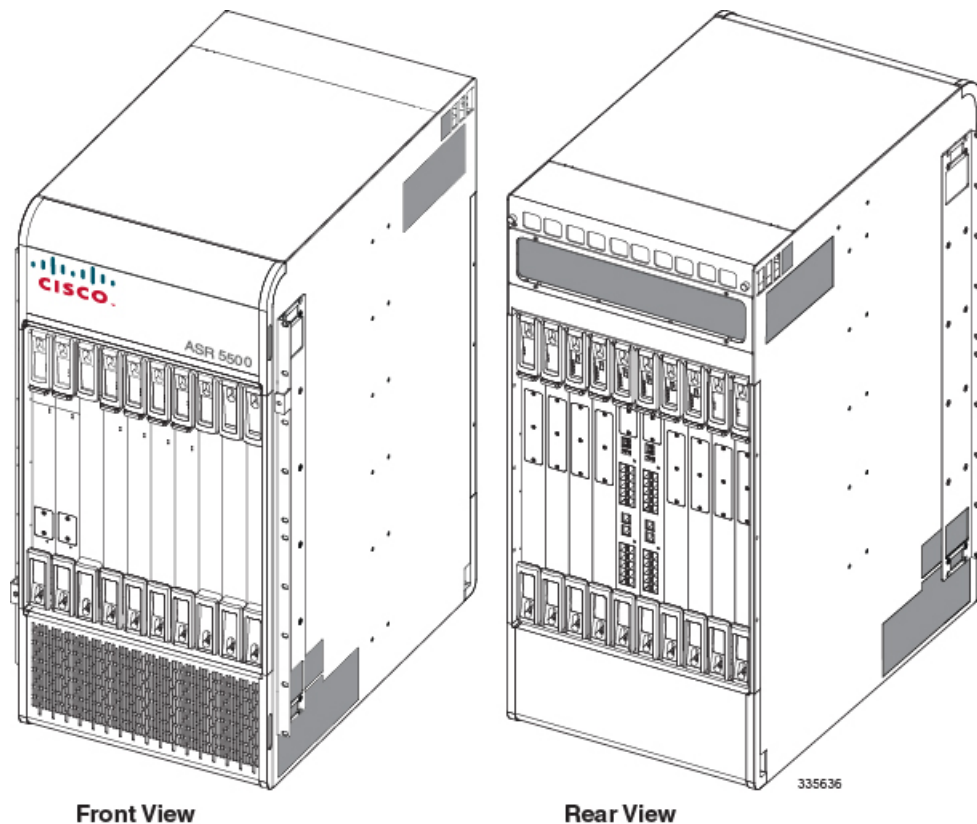

## Power

The chassis accepts up to eight 80-amp, -48 VDC power feeds across redundant power filter units (PFUs). The connections are made at the top-rear of the chassis. The front-mounted PFUs incorporate separate circuit breakers for each power feed.

## Cooling

The ASR 5500 uses two types of fan tray units and a total of four fan trays per chassis – two front fan trays and two rear fan trays. Air is drawn from the front and sides of the chassis and exhausted out the top rear and sides. Two fan trays are mounted at the bottom of the chassis with another two at the top. The bottom fan trays incorporate replaceable particulate air filters.

## Slot Numbering

The rear slots are numbered 1 through 10 with slots 5 and 6 used for the chassis management cards. The front slots are numbered 11 through 20. Lower slot numbers begin at the left side. There are no direct relationships between front and rear cards.

**Figure 3: ASR 5500 Slot Numbering – MIO/UMIO**

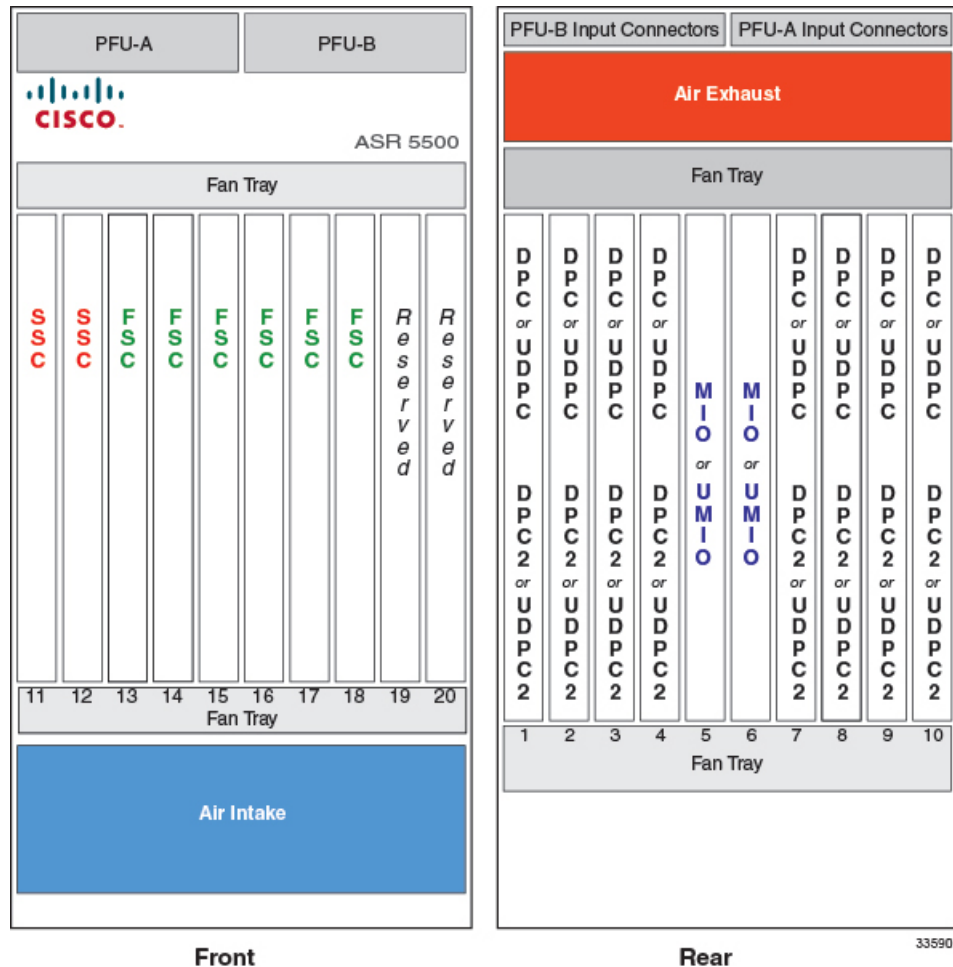

## Power Filter Units (PFUs)

Two PFUs mount at the top front of the chassis. Each PFU supports four power planes.

A total of eight -48 VDC, 80-amp power feeds are required for a full chassis. The eight feeds operate in a 4+4 redundant configuration. In lab environments where power redundancy is not required, four 80-amp lines can be used. For additional information on power requirements, see the *Technical Specifications* chapter.

## Cable Management System

The ASR 5500 cable management system consists of two components. The first is a tray that mounts at the rear of the chassis immediately below the card cage. The second is a cable management bracket that mounts to the front panel of each Management Input/Output card (MIO/UMIO).

Network cables are fed from either side or both sides of the tray and are then routed to the MIO/UMIO ports. The cables are secured to the cable management brackets on the MIO/UMIOs via cable ties or hook-and-loop straps, and within the cable management tray via hook-and-loop straps.

## Midplane

The midplane within the ASR 5500 chassis interconnects rear input/output ports and processing cards with front fabric cards. The larger rear cards support chassis management, input/output, and session processing. The smaller front cards provide fabric crossbars, persistent storage and system status monitoring.

The rear slots have a common midplane connector that is shared between the supported cards. This allows for different mixes of input/output and processing capacity depending on the customer's intended use. The two MIO/UMIO slots (5 and 6) have additional midplane connections to perform chassis control operations, including support for a serial Console port and dual remote management ports.

**Figure 4: ASR 5500 Midplane Buses**

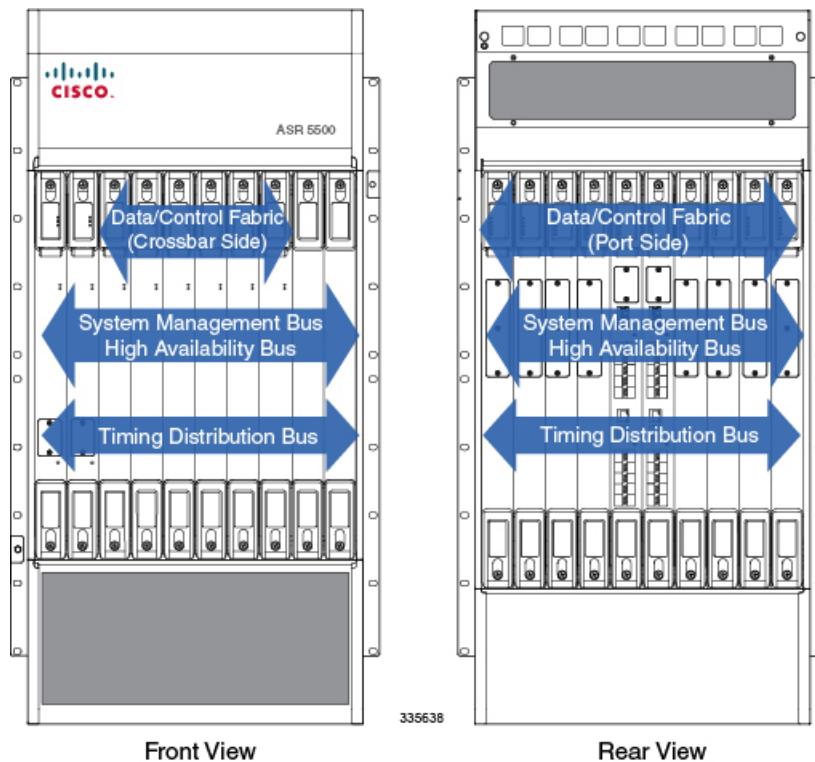

## Card Types

The ASR 5500 supports rear cards and front cards. Rear cards are larger and perform node management, packet processing and I/O functions (traffic sources). Front cards determine the amount of bandwidth for the

switching fabric (crossbars), and indicate the operating and alarm status of the ASR 5500. See the simplified block diagram below showing the ASR 5500 card architecture.

Figure 5: Block Diagram of Card Architecture – MIO/UMIO

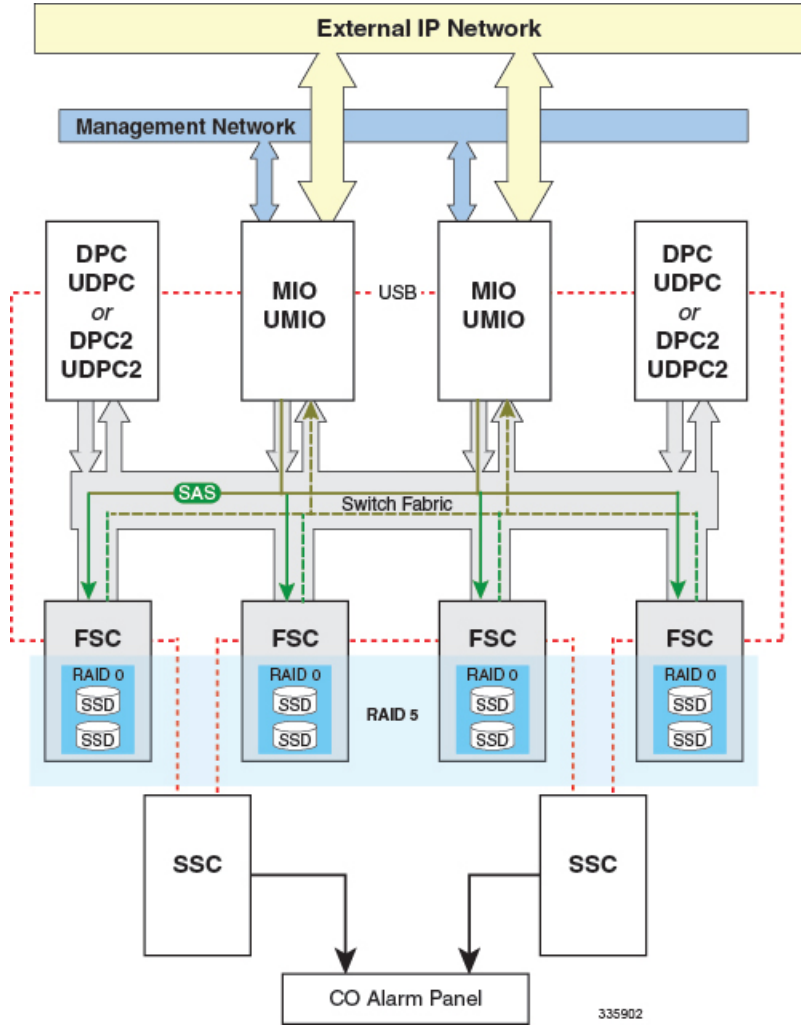
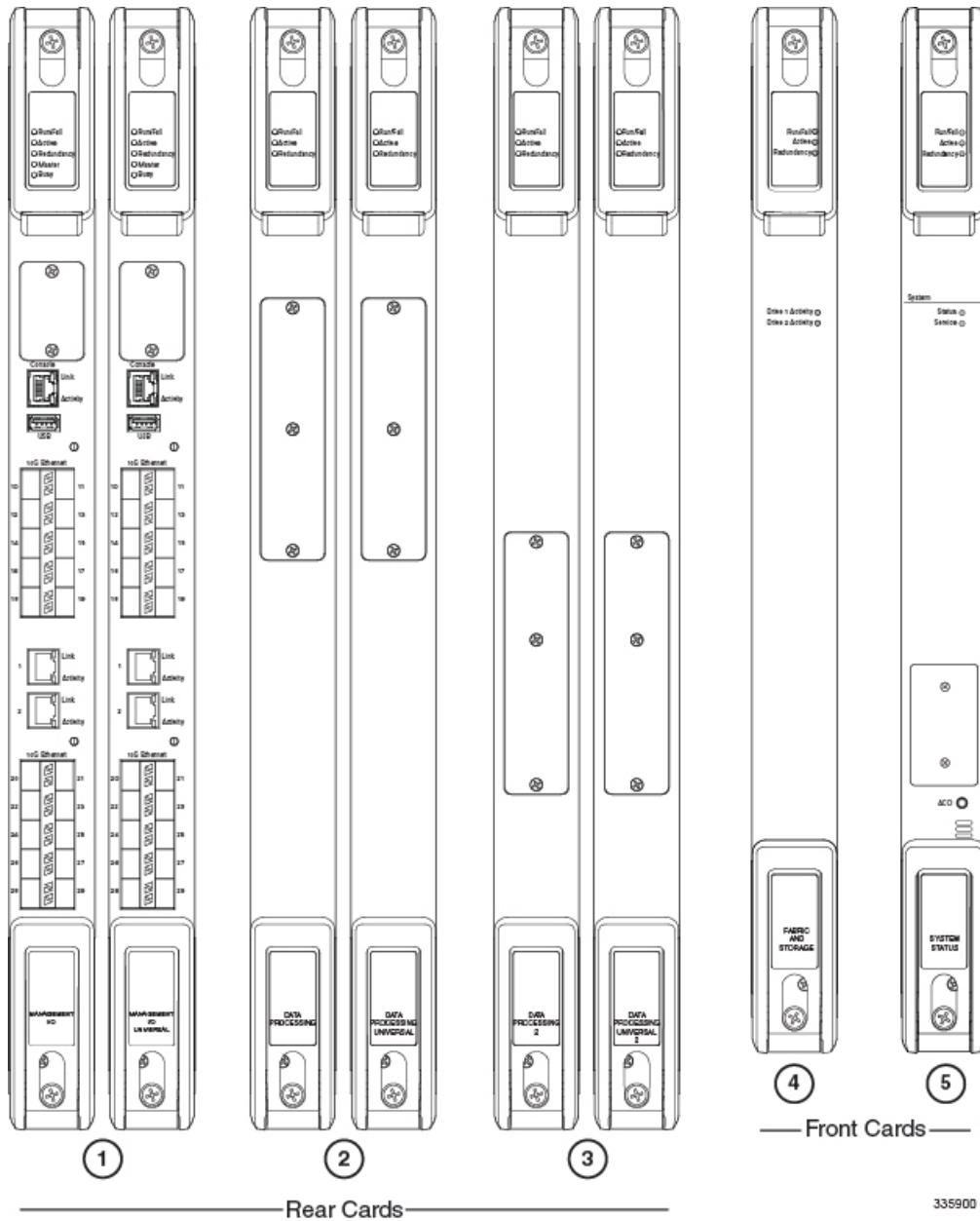

Figure 6: ASR 5500 Card Types – MIO/UMIO

Card Types



1	[LF] Management I/O (MIO) [RT] Management I/O Universal (UMIO)	2	[LF] Data Processing Card (DPC) [RT] Data Processing Card Universal (UDPC)
3	[LF] Data Processing Card 2 (DPC2) [RT] Data Processing Card Universal 2 (UDPC2)	4	Fabric and Storage Card (FSC)
5	System Status Card (SSC)	[LF] = Left image, [RT] = Right image	



## Rear Cards

The ASR 5500 supports several types of rear-mounted cards:

- [Management I/O, on page 9](#)
- [Data Processing Card, on page 10](#)  
–OR–
- [Data Processing Card version 2, on page 10](#)

The ASR 5500 supports ten rear cards. Each card is interconnected with the others via the switching fabric.

**Important**

---

UMIO cards, UDPCs and UDPC2s are direct replacements for MIO cards and DPC/DPC2s. However, a special Universal PID license must be purchased and installed on the chassis for each installed UMIO and UDPC/UDPC2. Contact your Cisco account representative for additional information.

---

## Management I/O

The ASR 5500 chassis supports two MIO /UMIO cards placed in the rear facing slots of the chassis. These cards perform chassis management, as well as local context and non-local context external I/O operations.

**Important**

---

The MIO/UMIO cards automatically implement 1:1 port redundancy (active/standby). Ports are 1:1 redundant across slots 5 and 6. For example, port 10 on the MIO in slot 5 is redundant with port 10 on the MIO in slot 6.

---

Each MIO/UMIO has:

- One CPU subsystem with 96 GB of RAM
- Four NPU subsystems

The two 10/100/1000Base-T (1GbE) ports on the front panel of MIO/UMIO cards can only be used for local context (OAM). An MIO/UMIO includes support for:

- Midplane connections for chassis control operations
- SAS storage controller for FSC solid state drives (SSDs)
- RS-232 serial console (RJ45) for CLI management
- USB port for an external flash device
- 32 GB SDHC internal flash device

MIO/UMIO cards support two daughter card (DCs) for external I/O interfaces (100 Gbps aggregate per DC). The optical ports on the daughter cards can only be used for non-local context. The currently available DC supports ten 10 GbE interfaces. The interface ports accept SFP+ SR and LR transceivers.

For additional information see the *MIO Cabling* chapter.



---

**Important** MIO/UMIO daughter cards are not user installable or replaceable.

---



---

**Important** MIO/UMIO cards are shipped with SFP+ SR or LR transceivers installed.

---

## Data Processing Card

The ASR 5500 chassis supports multiple DPCs/UDPCs in the rear facing slots of the chassis.

The DPC/UDPC has two identical CPU subsystems with each containing:

- Two six-core processors for a total of 24 cores per card
- 96 GB of RAM
- NPU for session data flow offload
- Crypto offload engines located on a daughter card

DPC/UDPCs manage subscriber sessions and control traffic.

## Data Processing Card version 2

The DPC2/UDPC2 is the second generation Data Processing Card (DPC) for the ASR5500. It offers increased performance versus the first generation DPC, while maintaining backwards compatibility with other ASR 5500 cards. The raw input/output has been increased from 80Gbps (DPC/UDPC) to 150Gbps (DPC2/UDPC2).



---

**Important** The DPC2 requires StarOS 18.0 or higher. The UDPC2 requires StarOS 18.2 or higher with a special Universal PID chassis license. See the *Chassis, UMIO, UDPC and UDPC2 License Requirements* appendix for additional information.

---

The DPC2/UDPC2 has three CPU subsystems. Each subsystem consists of two twelve-core processors that are paired with a Platform Controller Hub (PCH). This CPU configuration supports a total of 72 cores per card.

Each CPU subsystem is associated with 32 GB of DDR4 memory (total of 192 GB per DPC2) and a latest generation crypto offload engine.

The DPC2/UDPC2 is equipped with the Cisco Anti-Counterfeit Technology 2 (ACT2) chip. The ACT2 services multiple functions including:

- IEEE 802.1AR standard based Immutable Identity
- Extensible set of cryptographic functions
- Secure storage capabilities (cryptographic keys and credential storage).
- Installation of customers' own identity certificates (802.1AR LDevID)
- Source for true random entropy (NIST SP-800-90 certifiable)

The DPC2/UDPC2 is not equipped with NPUs.

**Important**

The DPC2/UDPC2 must not be intermixed with the DPC/UDPC in an ASR 5500 chassis. All data processing cards in the chassis must be of the same type.

## Front Cards

The ASR 5500 supports two types of front-mounted cards:

- [Fabric and Storage Card \(FSC\)](#), on page 11
- [System Status Card \(SSC\)](#), on page 12

The crossbars that comprise the switching fabric are on the FSCs. The ASR 5500 supports multiple FSCs. Each FSC provides six physical fabric planes. When fully populated, there are 24 fabric planes in the system. A physical fabric plane provides full-mesh connectivity between all traffic sources.

### Fabric and Storage Card (FSC)

The ASR 5500 chassis supports multiple FSCs in front facing slots of the chassis.

The FSC features:

- Fabric cross-bars providing in aggregate:
  - 120 Gbps full-duplex fabric connection to each MIO/UMIO
  - 60 Gbps full-duplex fabric connection to each DPC/UDPC or DPC2/UDPC2
- FSC-200GB – Two 2.5" serial attached SCSI (SAS), 200GB solid state drives (SSDs) with a 6 Gbps SAS connection to each MIO/UMIO. The SSDs support a RAID 0 configuration on the card.  
–OR–
- FSC-400GB – One 2.5" serial attached SCSI (SAS), 400GB solid state drive (SSD) with a 6 Gbps SAS connection to each MIO/UMIO. The FSC-400GB is interchangeable with the FSC-200GB, as long as the StarOS release supports the non-RAID 0 configuration of the single 400GB drive.

Every FSC adds to the available fabric bandwidth to each card. Each FSC connects to all MIO/UMIOs and data processing cards, with a varying number of links depending on the MIO/UMIO or data processing card slot. Three FSCs provide sufficient bandwidth while the fourth FSC supports redundancy.

**Important**

Although four FSCs are required for redundancy, the system can operate with three FSCs in the presence of a fourth failed FSC. However, you must install four FSCs for normal operation.

The ASR 5500 uses an array of solid state drives (SSDs) for short-term persistent storage. The RAID 5 configuration has each pair of drives on an FSC-200GB striped into a RAID 0 array; all the arrays are then grouped into a RAID 5 array. The single SSD on the FCS-400GB does not support RAID 0 but participates in the RAID 5 array.

Each FSC provides the storage for one quarter of the RAID 5 array in a four-FSC configuration. Data is striped across all four FSCs with each FSC providing parity data for the other three FSCs. The array is managed by the active MIO/UMIO.

When equipped with six FSCs, four of the FSCs are active (switch fabric) and form the RAID 5 array (all their SSDs are active). FSC-5 and FSC-6 are active (switch fabric) with their SSDs in Standby mode. Their SSDs will only become active in the event of an array failure.



---

**Important** The SSDs are not field replaceable units (FRUs). If an SSD fails the FSC must be replaced.

---



---

**Important** A minimum of three FSCs must be online at all times for the array to operate. When an FSC is removed, one RAID 0 array (FCS-200GB) is lost with the RAID 5 array providing redundancy. When equipped with six FSCs and one FSC in the RAID array fails, the SSDs on FSC-5 or FSC-6 will become active.

---



---

**Important** Removal of an FSC while the array is degraded or rebuilding may result in data loss.

---

The array appears under /hd-raid and is available to all data processing cards and MIO/UMIOs.

## System Status Card (SSC)

The ASR 5500 chassis supports two SSCs in front facing slots of the chassis. SSCs use dedicated slots (11 and 12) on the front side of the chassis.

The SSC card features:

- Three alarm relays (Form C contacts)
- Audible alarm with front panel Alarm Cutoff (ACO)
- System status LEDs

## LED Indicators

All ASR 5500 circuit cards incorporate light emitting diode (LED) status indicators. A base group appears on all cards. Card-specific indicators show the status of ancillary functions.

## LED Indicators Common to All Cards

*Table 1: Base LED Group*

Label	State	Meaning
Run/Fail	Off	Offline
	Green – Blink	Transitioning
	Green – Solid	Online
	Red	Failure
Active	Off	Not applicable
	Green – Blink	Transitioning
	Green – Solid	Active
Redundancy	Off	Not applicable
	Amber – Solid	Non-redundant
	Amber – Blink	Transitioning
	Green	Redundant

## LED Indicators on Specific Cards

*Table 2: Card-specific LED Group*

Label	State	Meaning
<b>MIO/UMIO</b>		
Master	Off	Not applicable
	Green – Blink	Transitioning
	Green – Solid	Master
Busy	Off	No activity
	Green	Storage activity
<b>Interface Ports</b>		
Link	Off	No link with network
	Amber – Blink	Transitioning
	Green – Solid	Linked with network

<b>Label</b>	<b>State</b>	<b>Meaning</b>
Activity	Off	No activity
	Green – Blink	Data exchange
<b>FSC</b>		
Drive 1 Activity	Off	No activity
	Green	Activity
Drive 2 Activity	Off	No activity
	Green	Activity
<b>SSC</b>		
System Status	Off	System offline
	Green	System online
	Red	Service loss
System Service	Off	System OK
	Amber	Failed component



## CHAPTER 2

# Technical Specifications

This chapter defines the technical specifications related to the installation of an ASR 5500 system.

It includes the following sections:

- [Physical Dimensions, page 15](#)
- [Environmental Specifications, page 16](#)
- [Mounting Requirements, page 20](#)
- [Power Requirements, page 21](#)
- [Central Office Alarm Interface, page 23](#)
- [Chassis Grounding, page 23](#)

## Physical Dimensions

The ASR 5500 can be mounted in any standard (EIA-310-D, IEC 60297) 19-inch (482.6 mm) equipment cabinet or telecommunications rack. The table below lists the dimensions for the chassis and each component that can be placed within the chassis.

**Table 3: ASR 5500 Physical Dimensions and Weights**

Component	Notes	Height	Width	Depth	Weight
Chassis (empty)	1	36.75 in.	17.25 in.	27.5 in.	131 lbs (51.25 kg)
Chassis as shipped	2	(93.3 cm)	(43.8 cm)	(69.8 cm)	226 lbs (102.5 kg)
Chassis (maximum)	3	36.75 in. (93.3 cm)	17.25 in. (43.8 cm)	32.0 in. (81.3 cm)	450 lbs (204.1 kg)
Chassis (shipping)	4, 5	50 in. (127 cm)	24 in. (61 cm)	32 in. (81.3 cm)	265 bs (120.2 kg)
Fan Tray – Front	—	1.625 in. (4.13 cm)	16.37 in. (41.6 cm)	5.625 in. (14.3 cm)	5.5 lbs (2.5 kg)
Fan Tray – Rear	—	2.125 in. (5.4 cm)	16.87 in. (42.9 cm)	18.5 in. (47 cm)	24.5 lbs (11.1 kg)

Component	Notes	Height	Width	Depth	Weight
Power Filter Unit	—	3.5 in. (8.9 cm)	8.5in. (21.6 cm)	21.5 in. (54.6 cm)	15 lbs (6.8 kg)
FSC	—	19.75 in. (50.2 cm)	1.75 in. (4.44cm)	6.75in. (17.1 cm)	6 lbs (2.7 kg)
SSC	—				4.5 lbs (2 kg)
MIO or UMIO	6	21.75 in. (55.24 cm)	1.75 in. (4.44 cm)	19.5 in. (49.5 cm)	18 lbs (8.16 kg)
DPC or UDPC	—				18.5 lbs (8.4 kg)
DPC2 or UDPC2	—				22.7 lbs (10.3 kg)
Baffle panel – front	—	19.75 in. (50.2 cm)	1.75 in. (4.44 cm)	6.25 in. (7 cm)	1 lb (0.45 kg)
Baffle panel – rear	—	21.75in. (55.2 cm)		18.625 in. 47.3 cm)	2.5 lbs (1.13 kg)

**Notes:**

- 1 No PFUs or fan trays.
- 2 Includes four Fan Tray Units and two PFUs.
- 3 Depth and weight with cable management tray installed and closed, and all card slots filled.
- 4 Includes shipping container, accessory box, and chassis with four Fan Tray Units and two PFUs
- 5 Width on the pallet forks.
- 6 Without cable management bracket.

## Environmental Specifications

The ASR 5500 is designed for deployment in unattended sites equipped with redundant power systems, redundant data communications connections, environmental controls (air conditioning, fire suppression), security devices and controlled access.

## Environmental Parameters

The table below lists the environmental parameters (operating and storage) for the ASR 5500 chassis.



**Table 4: Environmental Parameters**

Parameter	Subparameter	Range
Temperature	Operating	0 degrees C to +40 degrees C (32 degrees F to 104 degrees F)
	Short Term <sup>1</sup>	-5 degrees C to +50 degrees C (23 degrees F to 122 degrees F)
	Storage	-40 degrees C to +70 degrees C (-40 degrees F to 158 degrees F)
Humidity	Operating	20 to 80 percent non-condensing
	Storage	10 to 95 percent non-condensing
Altitude	Operating	197 ft. (60m) below to 5,905 ft. (1,800m) above sea level, maximum 40 degrees C (104 degrees F)
		5,905 ft. (1,800m) to 13,123 ft. (4000m) above sea level, maximum 30 degrees C (86 degrees F)
	Non-operating	197 ft. (60m) below to 49,212 ft. (15,000m) above sea level
Acoustic Noise	23 degrees C (73.4 degrees F)	81 dB [L <sub>WAd</sub> ] <sup>2</sup>
	26 degrees C (78.8 degrees F)	83 dB[L <sub>WAd</sub> ] <sup>2, 4</sup>
	27 degrees C (80.6 degrees F)	81 dB [L <sub>WAd</sub> ] <sup>2</sup>
	Max. Fan Speed 26 degrees C (78.8 degrees F)	96.5 dB [L <sub>WAd</sub> ] <sup>3, 4</sup>

**Notes:**

- 1 Short-term refers to a period of not more than 96 consecutive hours and a total of not more than 15 days in 1 year. (This refers to a total of 360 hours in any given year, but no more than 15 occurrences during that 1-year period.)
- 2 Within GR-63 limits for unattended operation.
- 3 Measured during GR-63 R4-97 testing.
- 4 Measured with DPC2 installed.

## Environmental Standards

The ASR 5500 has been successfully tested for compliance with the environmental standards listed in table below.

**Table 5: Environmental Compliance Standards**

Type	Standard
Acoustic Noise	Telcordia GR-63 Criterion [128]
Airborne Contaminants, Indoor Levels	Telcordia GR-63 Criterion [125]
Airborne Contaminants, Outdoor Levels	Telcordia GR-63 Criteria [126, 127]
Altitude	Telcordia GR-63 Criteria [74, 76]
Earthquake Zone 4	Telcordia GR-63 Criteria [110-112, 114, 115, 117, 119]
Electromagnetic Compatibility and Electrical Safety	Telcordia Technologies GR-1089-CORE
Operational Thermal, Operating Conditions	Telcordia GR-63 Criteria [72, 73]
Operational Thermal, Short-term Conditions	Telcordia GR-63 Criteria [72, 73]
Storage Environments, and Transportation and Handling	Telcordia GR-63 Criteria [69-71, 107-109, 124]
Thermal Heat Dissipation	Telcordia GR-63 Criteria [77, 79]
Electromagnetic Compatibility and Electrical Safety	Telcordia Technologies GR-1089-CORE
Radiated Emissions (Electric Field)	FCC 47 CFR, PART 15, CLASS A
Electromagnetic Compatibility	ETSI EN 300 386 v1.4.1
Environmental Conditions and Environmental Tests for Telecommunications Equipment	ESTI EN 300 019, ETSI EN 300 753

## Chassis Air Flow

Air flow within the ASR 5500 complies with Telcordia recommendations to ensure vertical convection cooling of the system.

As shown in the figure below, the lower fan trays pull ambient air inward from the front and side intake vents located near the bottom of the chassis. The air absorbs heat from system components as it passes over them.

The upper fan trays pull heated air up through the chassis and exhaust it through the side and rear exhaust vents located near the top rear of the chassis.



**Caution**

The environmental control system within the installation site must be able to maintain the ambient environment within the limits for operating temperature and humidity.

**Figure 7: Air Flow**

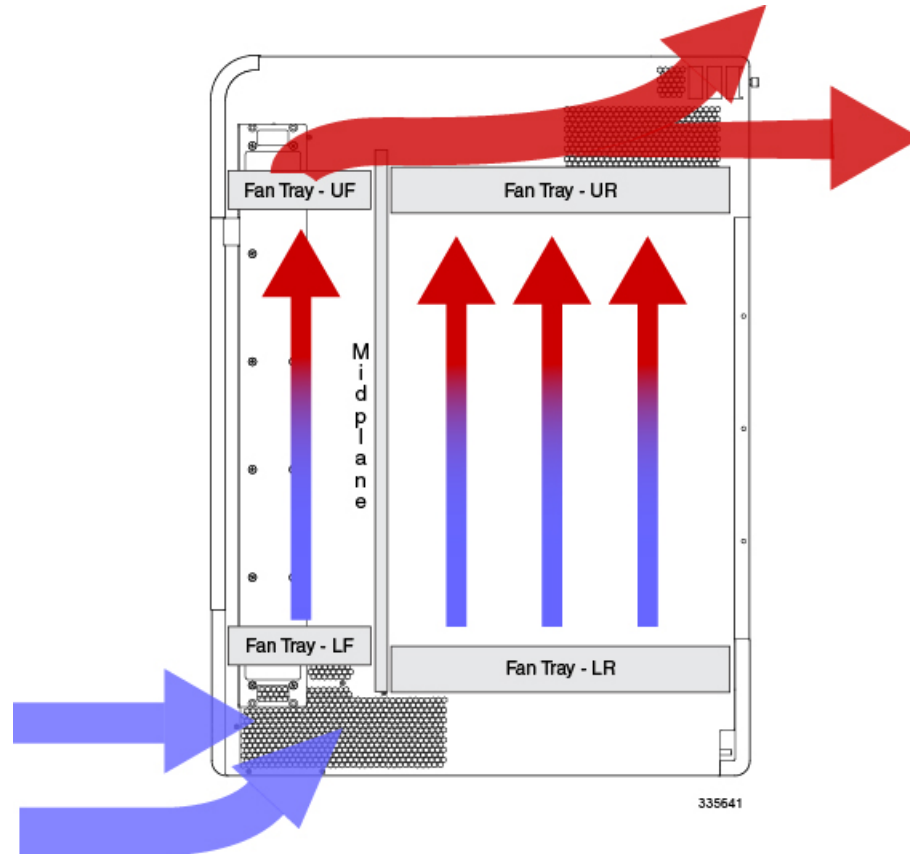

## Clearance

Ensure that the equipment rack or cabinet hardware does not hinder air flow at any of the intake or exhaust vents. Allow approximately 0.9 meter (36 inches) at the front and rear of the chassis for air flow and maintenance access.

**Caution**

The rear clearance is also necessary for removing and replacing the rear cards and fan trays (see the figure below). These units are very large and require additional clearance from cable management bars, PDUs, etc.

**Figure 8: Rear Clearance Zone**

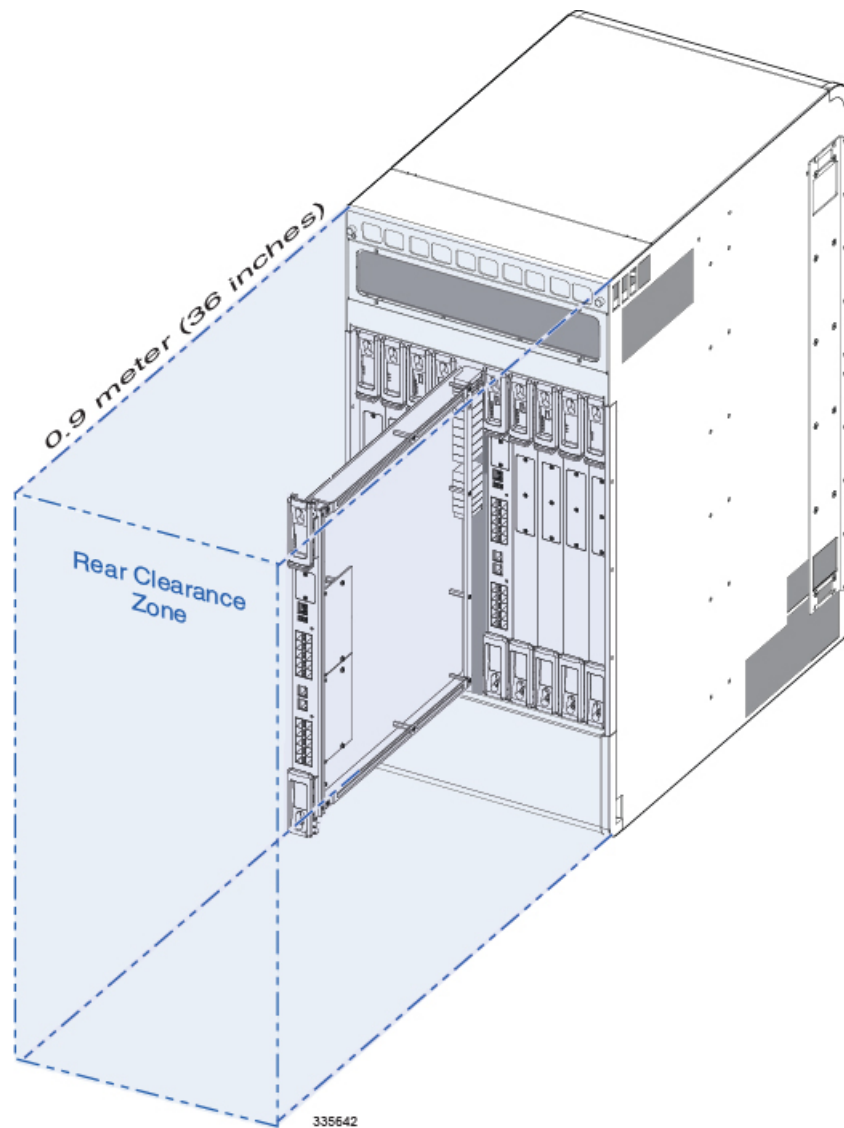

## Mounting Requirements

Each ASR 5500 chassis occupies 21 RU (rack units) within any standard (EIA-310-D, IEC 60297) 19-inch (482.6 mm) equipment rack or cabinet using the mounting brackets supplied with the chassis. Extension brackets (not supplied) may be used in conjunction with the chassis mounting brackets to install the chassis

in a standard 23-inch (584.2 mm) cabinet or rack. The chassis mounting brackets may be repositioned to support flush and mid-mount installations.

The chassis footprint is approximately 19-inch (48.26 cm) wide by 26.75 in. (67.9 cm) long.



**Important** This footprint does not include the rear-mounted cable management tray.

Two ASR 5500 chassis fit in 42 RU (73.5 in.) of space within an equipment rack or cabinet.



**Important** Rack mounting requires the use of industry-standard equipment racks or cabinets with supplier-recommended fasteners. The rack should be rated to accommodate the weight of one or two chassis and any auxiliary equipment.

## Power Requirements

### Power Specifications

The table below lists the power requirements for individual components of the ASR 5500 chassis.

**Table 6: ASR 5500 Power Requirements**

Component	Parameter	Values	Notes
<b>Chassis</b>	Input voltage per feed circuit (nominal)	-48VDC	—
	Input voltage per feed circuit (maximum)	-40VDC to -60VDC	—
	Power feed circuits per each PFU	4	1
	TUV rated peak current load per feed	80 amps @ -40 VDC	2
	Maximum power load per chassis	12,800 watts	3
<b>Cards</b>			
FSC	Maximum power	150 watts	—
SSC	Maximum power	10 watts	—
MIO or UMIO	Maximum power	650 watts	—
DPC or UDPC	Maximum power	630 watts	—
DPC2 or UDPC2	Maximum power	760 watts	—
<b>Fan Tray Unit</b>			
Front	Maximum power	60 watts each (2 per chassis)	—
Rear	Maximum power	940 watts each (2 per chassis)	—

Notes:

- 1 A minimum of four -48VDC power feeds are required on PFU-A to provide non-redundant power to a chassis and all its cards. Four additional power feeds are required on PFU-B for power redundancy (4+4 = 8).
- 2 Although the chassis may not draw 12.8 kW, a minimum of four 80-amp -48VDC feeds must be properly sized and wired to PFU-A to assure that all chassis slots are powered and available for future expansion. All power inputs on PFU-A must be connected to live power feeds to assure that all chassis card slots are energized.
- 3 The type and number of cards installed in the ASR 5500 chassis determine the actual -48VDC power draw. See [Example Power Calculations](#), on page 22.



**Important**

The power source must be a UL/CSA listed device with a regulated output no greater than -60VDC.



**Important**

The DC power Battery Return (BR) or positive terminal, must be grounded at the source end (power feed or mains power end).



**Important**

The DC power BR input terminal of the ASR 5500 is not connected to the equipment frame (chassis) and is configured as DC-I in compliance with GR-1089-CORE (sec.9.8.3).

## Example Power Calculations

### DPC/UPDC Full Chassis

This calculation assumes that a fully redundant ASR 5500 chassis will be equipped with DPC/UDPCs.

(8) DPC/UDPCs [8x630w] = 5040 watts

(2) MIO/UMIOs [2x650w] = 1300 watts

(4) FSCs [4x150w] = 600 watts

(2) SSCs [2x10w] = 20 watts

Fan Units [front and rear] = 2000 watts

Total = approximately 9 kW

### DPC2/UDPC2 Full Chassis

This calculation assumes that a fully redundant ASR 5500 chassis will be equipped with DPC2/UDPC2s.

(8) DPC2/UDPC2s [8x760w] = 6080 watts

(2) MIO/UMIOs [2x650w] = 1300 watts

(4) FSCs [4x150w] = 600 watts

(2) SSCs [2x10w] = 20 watts

Fan Units [front and rear] = 2000 watts

Total = approximately 10 kW

## Central Office Alarm Interface

The Central Office (CO) alarm interface on the SSC is a DB15 connector that supports three dry-contact (no voltage supplied) relay switches. Each of the Form C relays is rated to support a maximum switching current of 1A@30VDC.



### Caution

---

The alarm relay contacts should never be connected to high current draw devices, such as sirens or flashing incandescent lamps.

---

The three relays support both normally-open (NO) and normally-closed (NC) devices. For additional information, refer to the *SSC Alarm Cabling* chapter for details.

## Chassis Grounding

The ASR 5500 is suitable for installation as part of the Common Bonding Network (CBN) within a network telecommunications facility. It is not intended for installation in an Isolated Bonding Network (IBN).







## Installation Procedure Overview

This chapter briefly describes the steps and tools that are required to install the ASR 5500 chassis.



### Caution

The copper serial Console port, 1000Base-T management ports, and CO alarm interface of the ASR 5500 are suitable for connection to intra-building or unexposed wiring or cabling only. These ports **MUST NOT** be metallically connected to interfaces that connect to the outside plant (OSP) or its wiring. These interfaces are designed for use as intra-building interfaces only (Type 2 or Type 4 ports as described in GR-1089-CORE, Issue 5) and require isolation from the exposed OSP cabling. The addition of Primary Protectors is not sufficient protection in order to connect these interfaces metallically to OSP wiring.

It includes the following sections:

- [Installation Sequence, page 25](#)
- [Required Tools and Equipment, page 26](#)
- [Site Prerequisites, page 27](#)
- [ESD Precautions, page 28](#)
- [Standards Compliance, page 29](#)

## Installation Sequence

Installation of the ASR 5500 requires the completion of the following procedures:

- 1 Unpack the chassis and cards.
- 2 Determine which chassis mounting option to use: flush or mid-mount. Reposition the mounting brackets if necessary.
- 3 Install the chassis into a standard 19-inch equipment rack or telecommunications cabinet.
- 4 Connect the chassis ground point to site ground.
- 5 *Optional:* Install the Cable Management System.
- 6 Install SSC and FSC cards into the front of the chassis.
- 7 Install MIO/UMIO cards and DPC/UDPCs or DPC2/UDPC2s into the rear of the chassis.

- 8 Connect data cables to the local and external ports.
- 9 Connect power cables to the PFU terminals at the top rear of the chassis.
- 10 Apply power to the chassis.
- 11 Verify that the system powers up successfully.

The actual sequence for completing some of the above procedures may be adapted to suit local requirements and the availability of resources. For example, power cabling may be completed before circuit cards are installed in the chassis. However, the chassis must always be grounded immediately after being mounted in the rack or cabinet.

**Caution**

For personal safety and to minimize the risk of equipment damage, power must not be applied to the chassis until all other procedures have been completed.

## Required Tools and Equipment

This section lists the tools and equipment needed for installation.

### Hand Tools

The following hand tools are required for installation of the chassis circuit cards and PFUs:

- Cable/wire stripping tool – used to prepare the ends of power and ground cables for attachment to two-hole lugs.
- Knife, scissors or tin snips to cut shipping straps on the chassis container.
- Panduit crimping tool with 4 AWG die – used to crimp two-hole lugs on the ends of power feed cables.
- Phillips #2 and #1 screwdrivers – used to tighten thumb-screws on cards, fan trays, PFUs, and mounting brackets.
- 7/16-inch nut driver or ratchet and socket set – used to connect power and return, as well as chassis grounding cable lugs to PFU terminals.
- Torque wrench (rated 50 in-lb [5.65 N-m]) with 7/16-inch socket for tightening lugs to power terminals.
- Grounding wrist and/or heel straps for prevention of Electro-Static Discharge (ESD).

**Caution**

The inappropriate use of electric or pneumatic torque drivers, or power drill/impact drivers to loosen or tighten fasteners may result in damage to system components.

**Caution**

During installation, maintenance, and/or removal, wear a grounding wrist strap connected to the ASR 5500 chassis to avoid ESD damage to the components. Failure to do so could result in damage to sensitive electronic components and potentially void your warranty.

## Equipment

The following equipment is necessary to install the chassis and verify that it is ready for configuration:

- Standard 19-inch (48.26 cm) equipment rack (4-post or 2-post) or telecommunications cabinet with mounting hardware. **The rack/cabinet must be installed in accordance with OEM recommendations and local practices for electrical/grounding and seismic conditions.**
- Multiple -48 VDC power feeds terminated at the rack/cabinet.
- Voltmeter to measure input voltages at the PFU terminals.
- Heat gun for installing shrink wrap tubing over power cable lugs.
- Computer with a DB9 RS-232C serial port or a terminal server port that will connect to the RJ45 Console port on the chassis management MIO/UMIO cards for accessing the Command Line Interface (CLI).
- Pallet jack and/or chassis lift to move and position the ASR 5500 chassis. Without such mechanical assistance, moving and positioning the chassis will require multiple craftpersons trained to safely handle heavy rack-mounted units.

## Site Prerequisites

This section summarizes power, grounding, environment, and clearance requirements that must be met prior to installing and operating the ASR 5500. For detailed information, refer to the *Technical Specifications* chapter.

## Power and Grounding

Each PFU requires eight power feeds of 80A @ -48VDC (nominal). The feeds should be routed to the installation rack from the site power supply using adequately sized conductors and circuit breakers in accordance with local electrical codes. For additional information on power requirements, see the *Technical Specifications* chapter.

The chassis must be grounded to a site ground point using the recommended conductors and lugs. The ground point should be in close proximity to the ASR 5500 chassis to assure adequate conductivity.

## Environment

The site's heating ventilation and air conditioning (HVAC) systems must be sized to maintain the operating temperatures and relative humidity specified in the *Technical Specifications* chapter. HVAC capacity requirements will vary based on the system configuration and associated power draw, as well as the operational characteristics of other equipment installed at the site.

## Clearance

Adequate clearance must be maintained at the front and rear of the ASR 5500 chassis to assure proper air flow and allow maintenance access for the installation, removal and replacement of components. The recommended clearance is 36 inches (92 centimeters) at the front and rear of the chassis.

## ESD Precautions

Electro-Static Discharge (ESD) can cause serious damage to the chassis, its sub-components and/or the cards installed in the chassis. To prevent damage from ESD, you must take proper grounding precautions before handling the chassis or any of its components.

The chassis and its mounting brackets are equipped with ESD jacks (see the figure below). Use the jacks in conjunction with grounding wrist straps when handling the chassis and/or its components. The following figure shows the location of the jacks.

Before you can use the ESD jacks on the ASR 5500 chassis and its mounting brackets, you must first connect the chassis to ground according to the instructions in the *Chassis Installation* chapter of this document.

**Figure 9: Locations of ESD Jacks on the ASR 5500 Chassis**

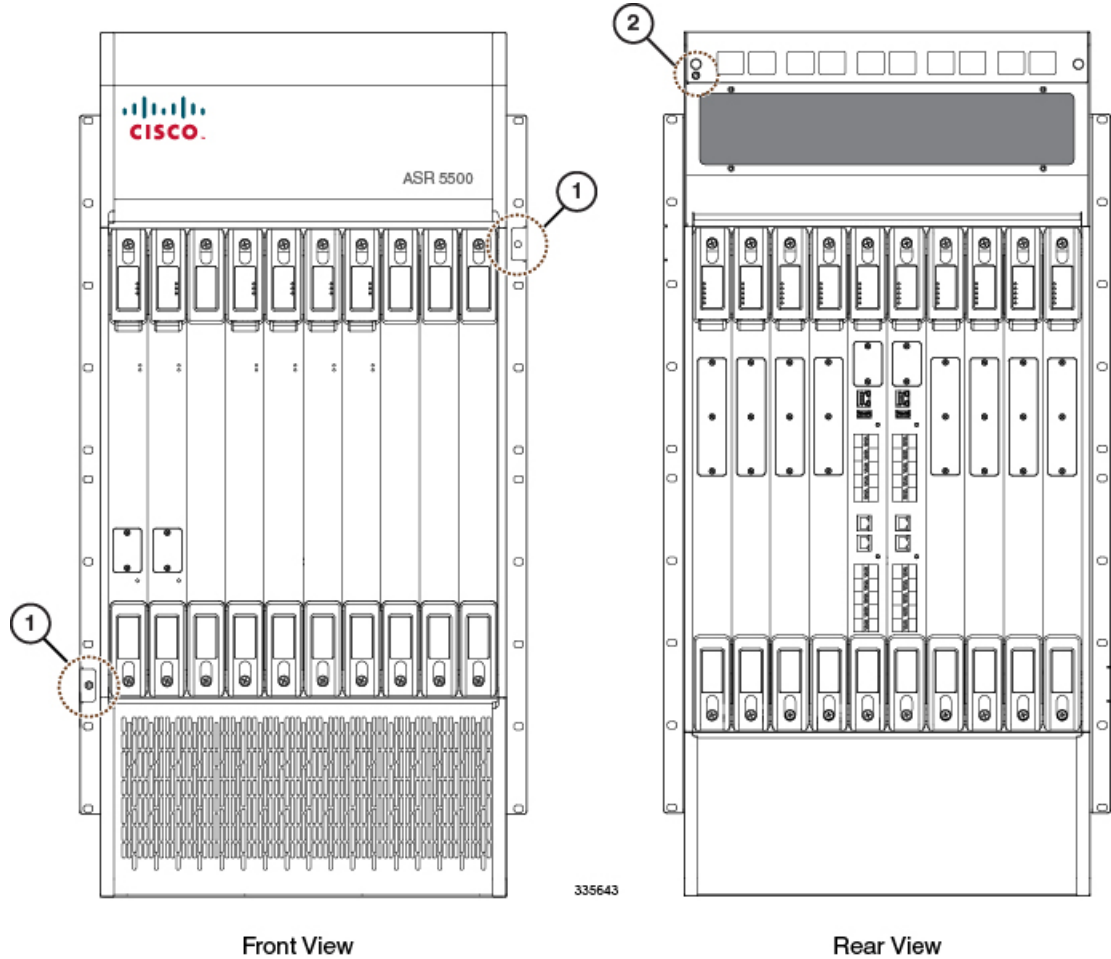

1	Front ESD jack	2	Rear ESD jack
---	----------------	---	---------------

## Standards Compliance

### FCC Warning

This device complies with the limits for a Class A digital device, pursuant to Part 15 of the FCC Rules and Regulations. Operation is subject to the following two conditions:

- This device may not cause harmful interference.

- This device must withstand any interference received, including interference that may cause undesired operation.

The system platform has been tested and found to comply with the limits for a Class A digital device pursuant to Part 15 of the FCC Rules and Regulations. These limits are designed to provide reasonable protection against harmful interference when this equipment is operated in a commercial environment. This equipment generates, uses, and can radiate radio-frequency energy and, if not installed and used in accordance with the instruction manual, may cause harmful interference to radio and television communications. Operation of this equipment in a residential area is likely to cause interference in which case the user will be required to correct the interference at his or her own expense.

Modifications to this product not authorized by Cisco could void the FCC approval and negate your authority to operate the product.

Shielded cables must be used with this unit to ensure compliance with the FCC Class A limits.

## ICS Notice

This Class A digital apparatus complies with Canadian ICES-003.

Cet appareil numérique de la classe A est conforme à la norme NMB-003 du Canada.

## Laser Notice

The laser devices in this equipment are Class 1 devices. Class 1 laser devices are not considered to be hazardous.



## Chassis Installation

This chapter describes how to install the ASR 5500 chassis and its components.



### Important

The ASR 5500 is suitable for installation in Network Telecommunication Facilities designed for unattended equipment operation.

This chapter includes the following sections:

- [Mounting Options, page 31](#)
- [Weight Considerations, page 32](#)
- [Unpacking the Chassis, page 32](#)
- [Reducing the Weight of the Chassis Prior to Installation, page 35](#)
- [Installing the Chassis, page 40](#)
- [Grounding the Chassis, page 43](#)
- [Re-Installing Chassis Components, page 45](#)
- [Cable Management System, page 47](#)

## Mounting Options

There are two options for mounting the chassis in a standard 19-inch equipment rack or telecommunications cabinet:

- **Flush mount:** In this configuration, the flanges of the mounting brackets are flush with the front of the chassis. This is the default configuration as shipped. This method is typically used to mount the chassis in a 4-post rack or equipment cabinet. Refer to
- **Mid-mount:** In this configuration, the flanges of the mounting brackets are recessed from the front of the chassis. To do this, the mounting brackets must be removed and reinstalled toward the middle of the chassis. This method is typically used to mount the chassis in a two-post rack. Refer to

## Weight Considerations

The shipping weight of the chassis is approximately 226 lbs (102.5 kg). Please consider the following recommendations before proceeding:

- If available, use an equipment lift to move the chassis and position it into the rack/cabinet.
- If a lift is not available, reduce the weight of the chassis by following the instructions in [Reducing the Weight of the Chassis Prior to Installation](#), on page 35.
- Remove all obstructions in the path from the delivery location to the rack/cabinet.
- At least two people should perform the installation. These individuals should be physically able to lift and control the weight of the chassis.
- When lifting any heavy object, remember to bend at the knees and lift with your legs. Bending at the waist and lifting with your back could cause personal injury.



### Important

The ASR 5500 chassis is shipped with no circuit cards installed. Only the PFUs, fan trays and air filters are installed. The circuit cards are shipped in separate cartons.



### Caution

If you are mounting two chassis in a single rack, verify that the rack is rated to handle the combined, fully loaded weight of both chassis and any ancillary equipment.

## Unpacking the Chassis

The ASR 5500 chassis is shipped on a palletized container.



### Important

The front and rear circuit cards are packaged and shipped in separate cartons.



### Important

Locate the packing list for the shipment and verify that all components have been received.



### Important

Safely store the shipping container and its components in case the chassis must be shipped to another site or returned for repair.

## Move the Container to the Installation Site

Before unpacking the chassis, use a pallet jack to move the container as close to the final installation site as possible. The cardboard cap and sleeve will protect the chassis from damage when moving the container.



The chassis container measures:

- Height = 50 in. (127 cm)
- Width = 24 in. (61 cm)
- Depth = 32 in. (81.3 cm) [width on the pallet forks]
- Weight = 265 lbs (120.2 kg)

## Unpack the Chassis



### Caution

You should wear protective gloves and safety glasses when handling the shipping crate banding while unpacking the system. The straps that connect the packaging material are capable of inflicting damage to your skin or eyes if not handled properly.

### Step 1

Cut the straps that secure the cap and card board sleeve to the pallet. Remove the straps from the pallet and discard.

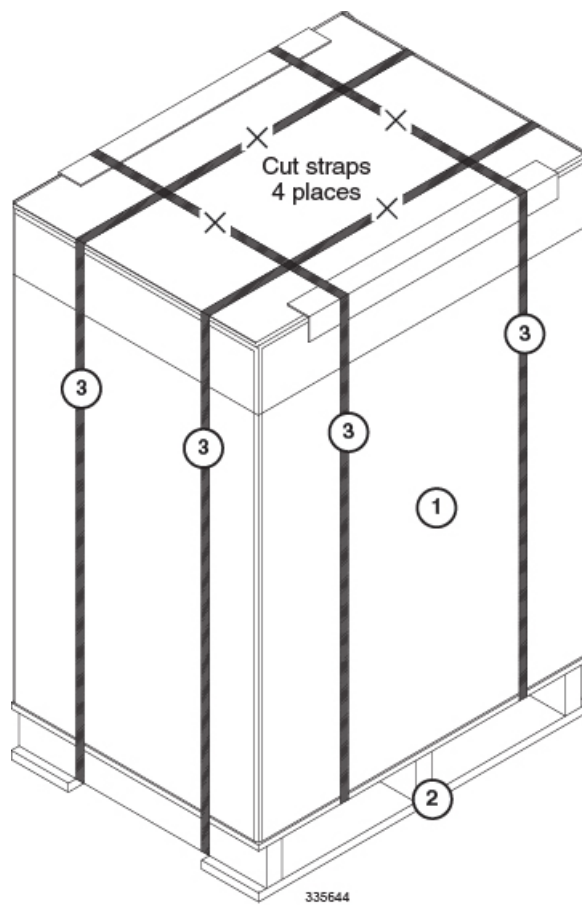

## Unpack the Chassis

1	Container sleeve	2	Pallet
3	Strap		

**Step 2** Remove the cardboard cap from the top of the container.

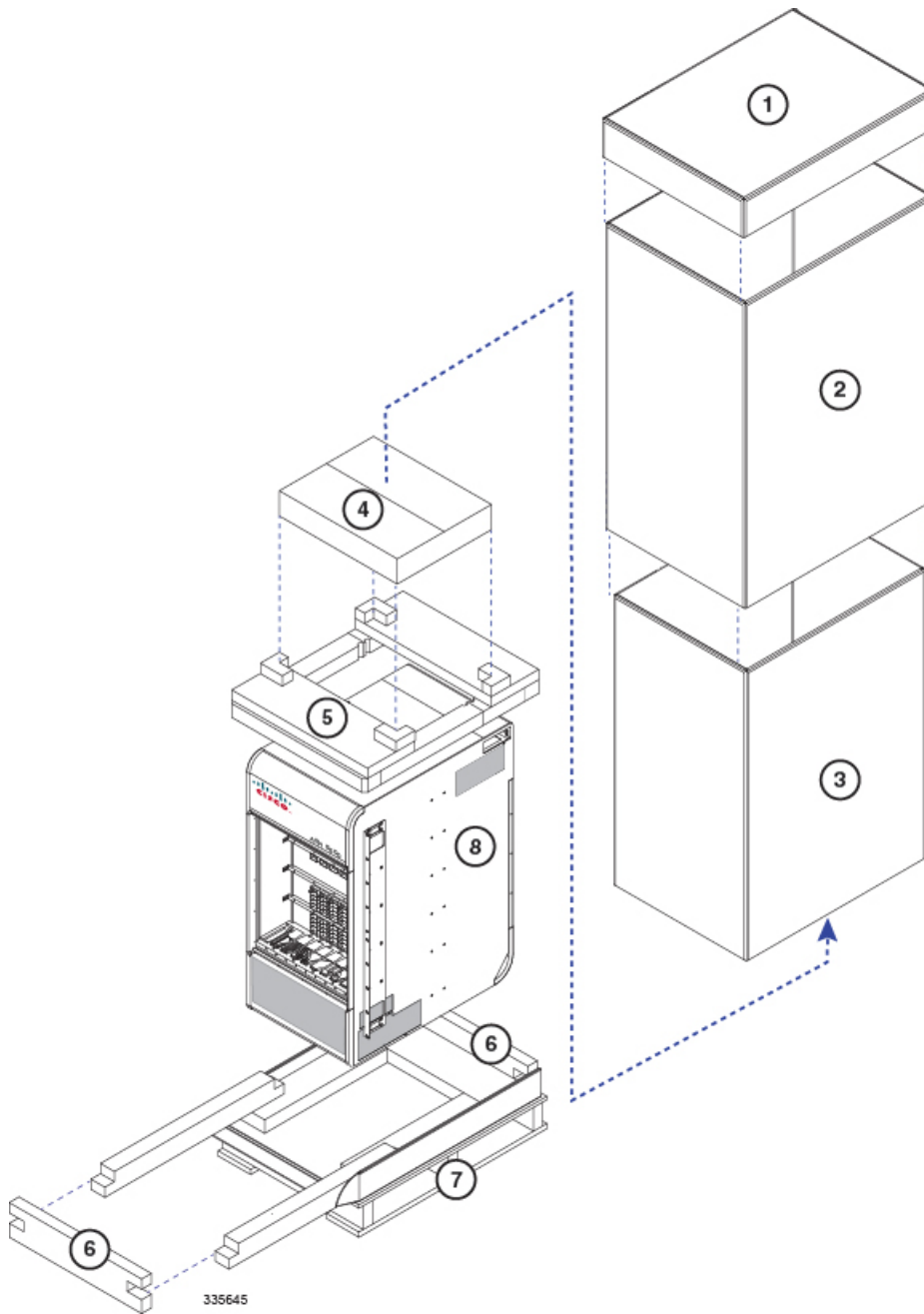

1	Cardboard top	2	Outer sleeve
3	Inner Sleeve	4	Accessory box
5	Foam Cap	6	End cap
7	Pallet	8	Plastic bag (not shown)

- Step 3** Lift the outer cardboard sleeve up and over the top of the chassis.
- Step 4** Lift the inner cardboard sleeve up and over the top of the chassis.
- Step 5** Remove the accessory box. This box contains miscellaneous hardware items and spare air filters.
- Step 6** Remove the foam cap from the top of the chassis.
- Step 7** Remove the bottom front and rear end caps from the base of the chassis.
- Step 8** Remove the plastic bag that covers the chassis.
- Step 9** If you will be removing chassis components to reduce the weight of the chassis, leave the chassis on the pallet and proceed to [Reducing the Weight of the Chassis Prior to Installation, on page 35](#)
- Step 10** Use a chassis lift or multiple craftpersons to lift or slide the chassis off the shipping pallet. Proceed to [Installing the Chassis, on page 40](#).

## Reducing the Weight of the Chassis Prior to Installation

You can reduce the weight of the chassis prior to installation by removing the upper and lower fan trays, and the PFUs. Follow the instructions below to safely remove these components prior to installation.



### Caution

During installation, maintenance and/or removal, wear a grounding wrist strap to avoid ESD damage to the components. Connect the strap to a ground point on the rack/cabinet frame. Failure to do so could result in damage to sensitive electronic components and potentially void your warranty.

## Removing the Fan Trays



### Caution

To avoid personal injury and/or damage to the fan trays, be sure to support each fan tray's weight from its front and rear as you slide it completely out of the chassis.

## Remove the Upper Front Fan Tray

- Step 1** At the front of the chassis, remove the cover panel from the top of the chassis. Firmly grasp the side edges of the panel and pull up and away to unsnap the panel. Put the panel safely aside.

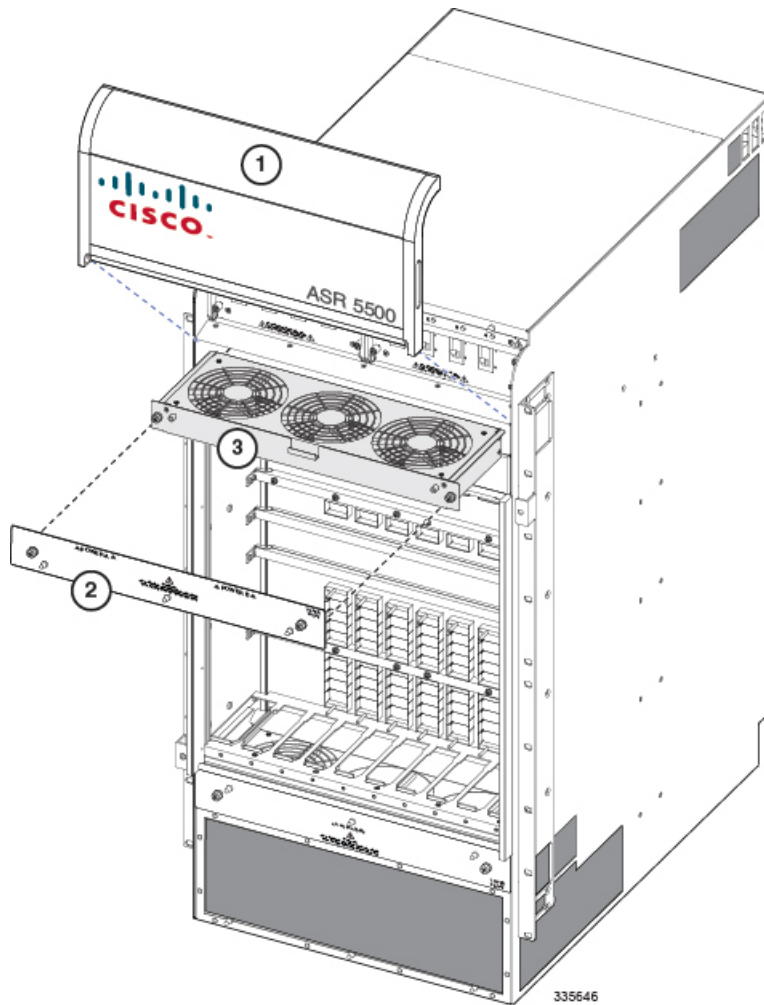

1	Cover panel	2	Access panel
3	Front fan tray		

- Step 2** Use a #1 Phillips screwdriver to loosen the screws and remove the access panel from the upper-front of the chassis. Place it safely aside.
- Step 3** Loosen the two screws on the fan tray.
- Step 4** Grasp the center pull on the front of the fan tray and pull. The fan tray should unseat from the midplane connector and slide out of the chassis.
- Step 5** Place the fan tray safely aside.
- 

## Remove the Lower Front Fan Tray

---

- Step 1** Remove the cover panel from the bottom of the chassis. Firmly grasp the side edges of the panel and pull down and away to unsnap the panel. Put the panel safely aside.
- Step 2** Use a #1 Phillips screwdriver to loosen the screws and remove the access panel from the lower-front of the chassis. Place it safely aside.
- Step 3** Loosen the two screws on the fan tray.
- Step 4** Grasp the center pull on the front of the fan tray and pull. The fan tray should unseat from the midplane connector and slide out of the chassis.
- Step 5** Place the fan tray safely aside.
- 

## Remove the Upper Rear Fan Tray

---

- Step 1** At the rear of the chassis, remove the cover panel from the top of the chassis just below the vent panel. Firmly grasp the side edges of the panel and pull up and away to unsnap the panel. Put the panel safely aside.
- Step 2** Loosen the screws and remove the upper fan tray access panel from the chassis. Place it safely aside.
- Step 3** Use a #1 Phillips screwdriver to loosen the two screws that secure the handle to the front of the fan tray.
- Step 4** Flip up and grasp the fan tray handle and pull. The fan tray should unseat from the midplane connector and slide out of the chassis. Support the bottom of the fan tray unit with one hand as you pull it away from the chassis.
- Step 5** Place the fan tray unit safely aside.
- 

## Remove the Lower Rear Fan Tray

---

- Step 1** Remove the cover panel from the bottom of the chassis. Firmly grasp the side edges of the panel and pull down and away to unsnap the panel. Put the panel safely aside.

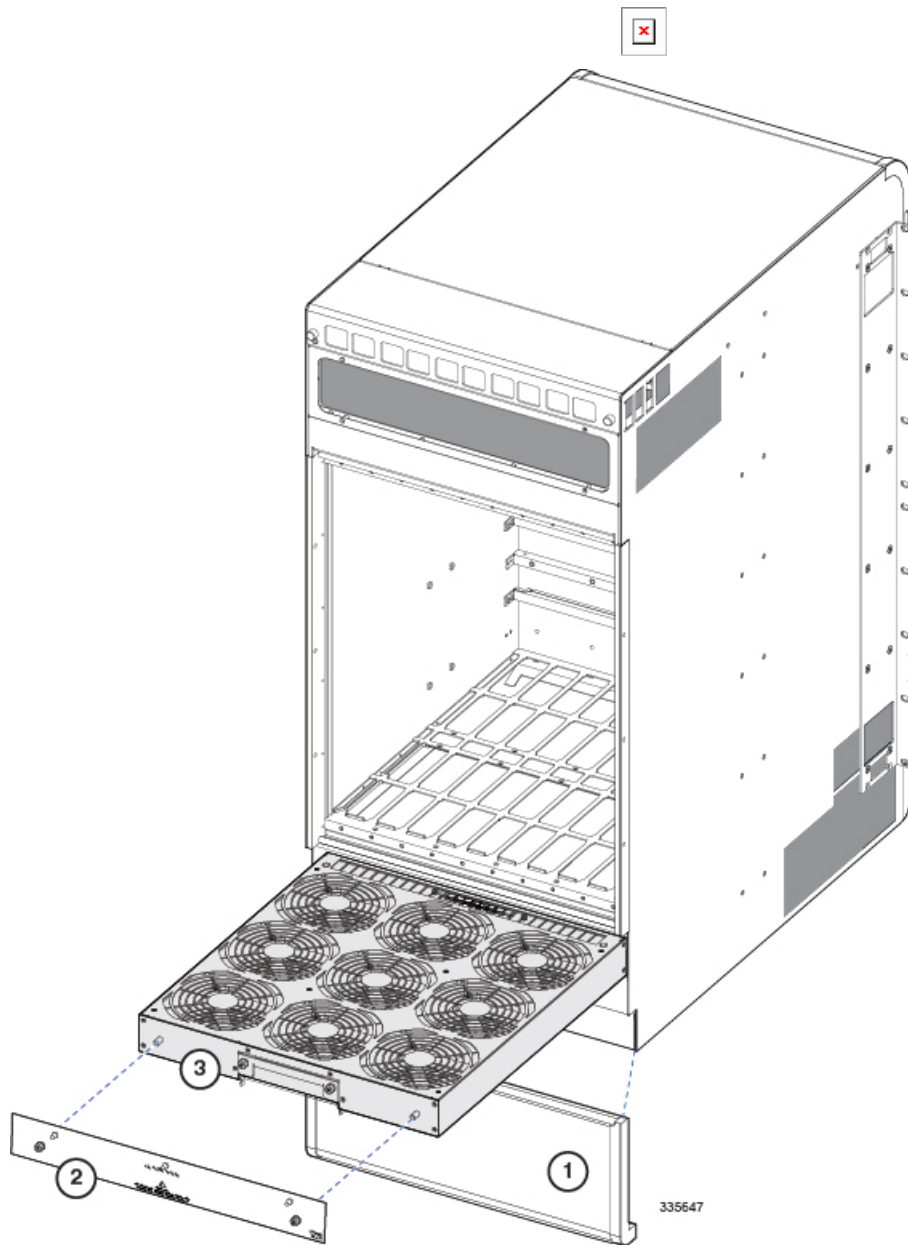

1	Cover panel	2	Access panel
3	Rear fan tray		

- Step 2** Loosen the two screws and remove the access panel from the upper-front of the chassis. Place it safely aside.
- Step 3** Use a #1 Phillips screwdriver to loosen the two screws that secure the handle to the front of the fan tray.
- Step 4** Flip up and grasp the fan tray handle and pull. The fan tray should unseat from the midplane connector and slide out of the chassis. Support the bottom of the fan tray unit with one hand as you pull it away from the chassis.
- Step 5** Place the fan tray unit safely aside.
- 

## Removing the PFUs

---

- Step 1** Locate the left PFU bay (Power A) on the upper-left front of the chassis.

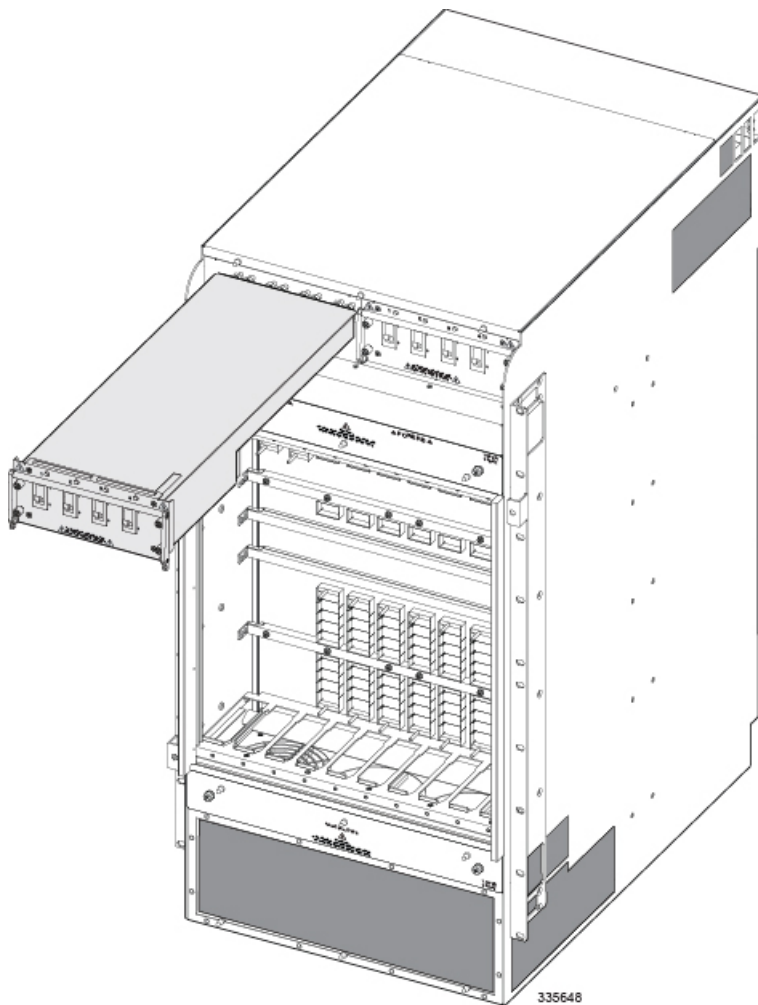

- Step 2** Use a Phillips #2 screwdriver to loosen the four screws that secure the PFU to the chassis.
- Step 3** Grasp the handle on the PFU and pull downward to free the unit from the power plane connectors. **It will take considerable force to move the handle downward and free the PFU from the power plane connectors.**
- Step 4** Pull the PFU toward you. The PFU should slide easily out of the chassis. Place it safely aside.
- Step 5** Repeat step 2 through step 4 for the PFU located in the right bay (Power B).
- 

## Installing the Chassis



### Important

If you are installing more than one chassis in an equipment rack, install the first chassis at the bottom of the rack.

---



### Caution

When handling or moving the chassis, lift the chassis from the bottom only. Lifting it by any other part could damage the chassis.

---



### Caution

During installation, maintenance and/or removal, wear a grounding wrist strap to avoid ESD damage to the components. Connect the strap to a ground point on the rack/cabinet frame. Failure to do so could result in damage to sensitive electronic components and potentially void your warranty.

---

## Mounting the Chassis

### Flush Mount

- Step 1** Position the chassis in the equipment rack so that the flanges of the mounting brackets at the front of the chassis are flush with the mounting rails of the equipment rack.



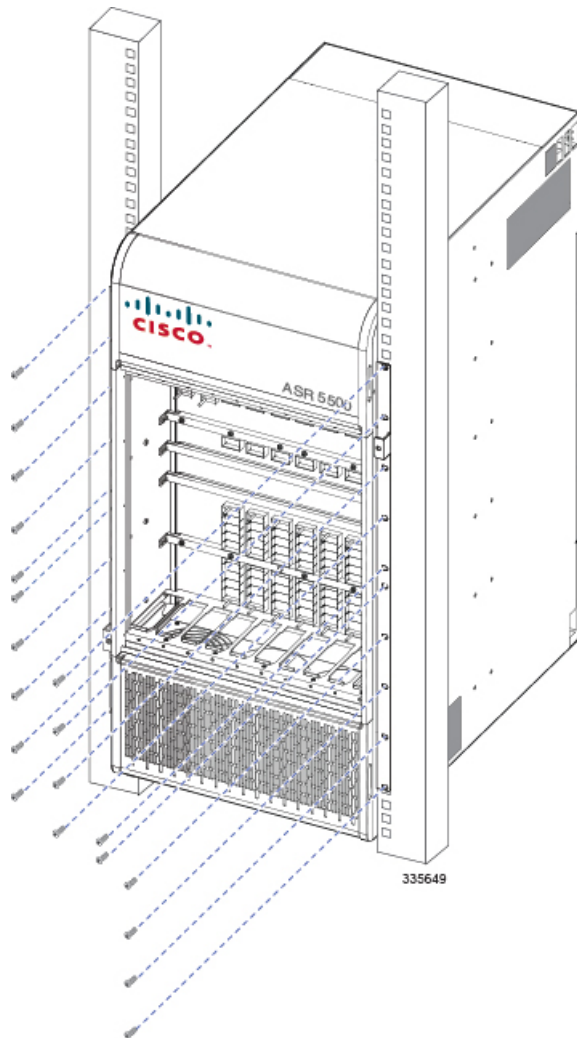

- Step 2** Mount the chassis to the rack rails using the OEM hardware that was supplied with the equipment rack. Begin with the two bottom holes and work your way up until all holes on each flange are secured.
- Step 3** Repeat step 1 and step 2 if you are installing an additional chassis in the equipment rack/cabinet.
- Step 4** If you took steps to reduce the weight of the chassis prior to installation, refer to [Re-Installing Chassis Components](#), on page 45. Otherwise, proceed to [Grounding the Chassis](#), on page 43.

## Mid Mount

- 
- Step 1** On the side of the chassis, use a Phillips #2 screwdriver to remove the twelve flathead screws that secure the mounting bracket to the chassis.
- Step 2** Place the mounting bracket over the middle set of mounting holes on the side of the chassis and secure it to the chassis with the screws you removed in step 1.
- Step 3** Repeat step 1 and step 2 and reposition the bracket on the opposite side of the chassis.
- Step 4** Position the chassis in the equipment rack so that the flanges of the mounting brackets are flush with the mounting rails of the equipment rack.

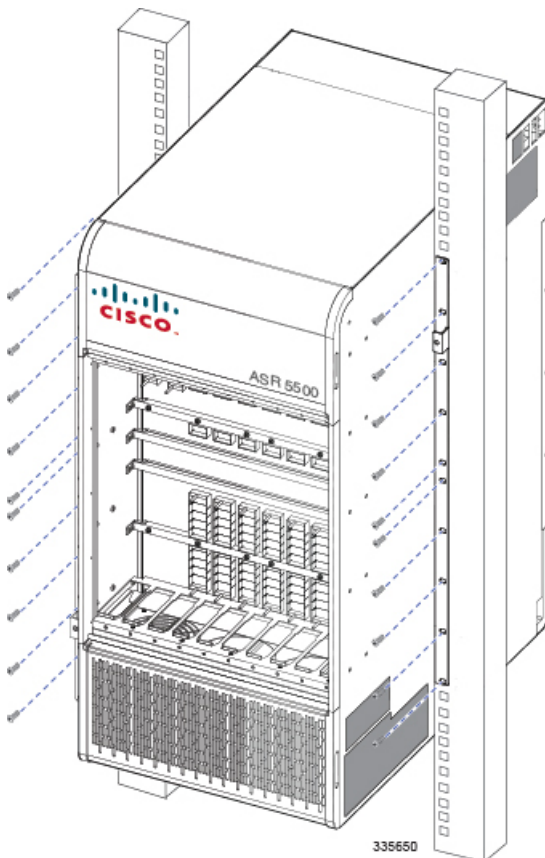

- Step 5** Mount the chassis to the rack rails using the OEM hardware that was supplied with the equipment rack. Begin with the two bottom holes and work your way up until all holes on each flange are secured.
- Step 6** If you took steps to reduce the weight of the chassis prior to installation, refer to [Re-Installing Chassis Components](#), on page 45. Otherwise, proceed to [Grounding the Chassis](#), on page 43.
-

## Grounding the Chassis

The chassis must be properly grounded prior to installing any chassis components or cards. The chassis and the equipment rack/cabinet must be connected to the same ground point.

**Caution**

Failure to properly ground the chassis could result in personal injury and/or damage to the chassis and its components.

There are two sets of grounding terminals located at the lower-rear of the chassis. Figure 4-8 shows the location of these terminals and provides specifications for the appropriate lug and cable size.

## Ground Cabling

**Important**

The ASR 5500 is suitable for installation as part of the Common Bonding Network (CBN) in a network telecommunications facility. It is not intended for installation in an Isolated Bonding Network (IBN).

A 2-hole lug (Panduit LCD4-14A-L) is supplied for grounding the chassis. The lug must be crimped to the end of a ground cable using Panduit crimp tool part number CT-720-1 (die color: gray, P29). The wire strip length is 7/8-inch (22 mm),

The minimum, recommended stranded cable size is 4 AWG. the cable length to the site ground point should not exceed 70 feet (21 m) one way.

The method of connection is: chassis -> lug -> flat washer -> nut (7/16-inch).

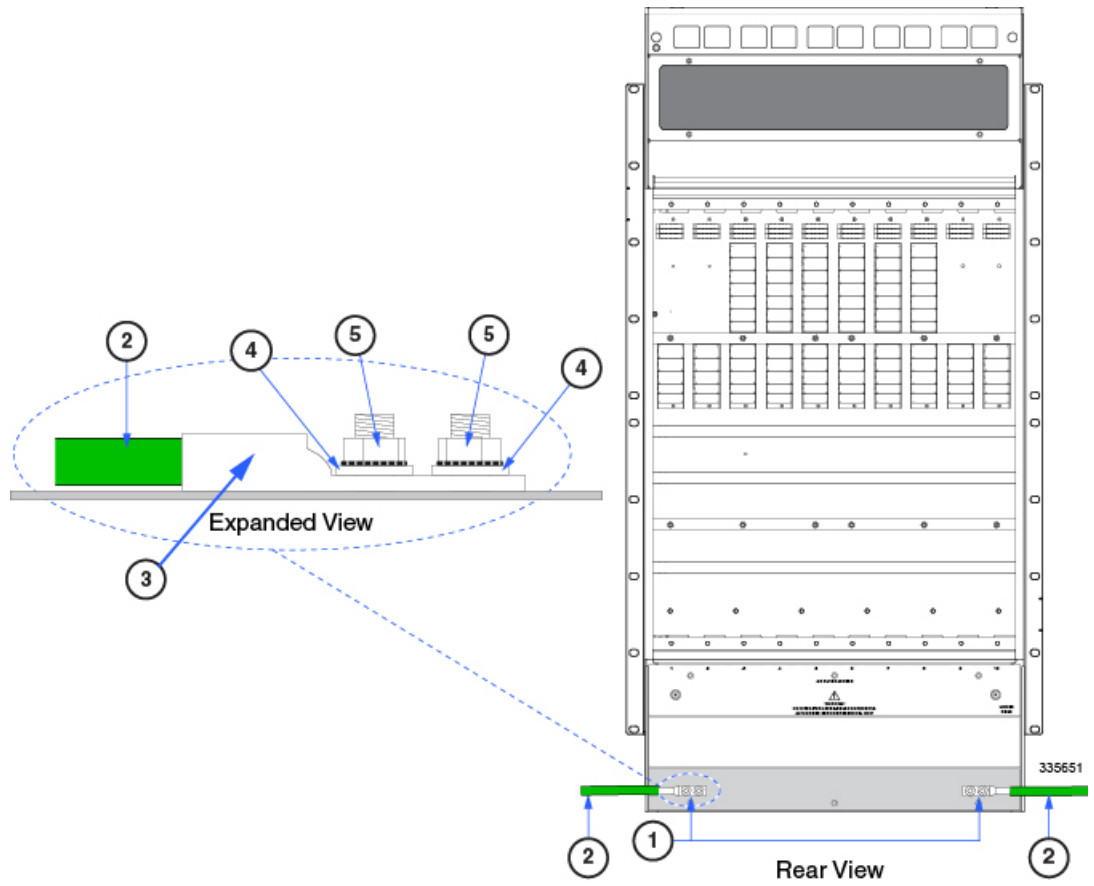

1	Chassis ground point	2	Grounding cable
3	2-hole lug	4	Flat washer
5	7/16-inch Kep nut		

## Grounding Procedure

- 
- Step 1** Remove the rear bottom cover from the chassis. Grasp both sides of the cover and pull out and up to unsnap the cover.
- Step 2** Locate the ground terminal on the lower-left corner at the rear of the chassis.
- Step 3** Use a 7/16-inch nut driver or socket wrench to remove the Kep nuts and washers from each post.
- Step 4** Insert the lug connected to the grounding cable over the two posts.
- Step 5** Secure the lug to the ground terminals with the Kep nuts and washers you removed in step 2. The nuts should be torqued to 50 in-lb (5.65 N-m).
- Step 6** Repeat step 2 through step 5 to connect the ground cable to the grounding posts on the lower-right corner at the rear of the chassis.
- Step 7** If you took steps to reduce the weight of the chassis prior to installation, refer to the instructions in [Re-Installing Chassis Components](#), on page 45. Otherwise, proceed to the *Card Installation* chapter.
- 

## Re-Installing Chassis Components

If you removed chassis components to reduce the weight of the chassis, re-install the components by completing the following the procedures.

**Caution**

---

During installation, maintenance, and/or removal, wear a grounding wrist strap connected to the ASR 5500 chassis to avoid ESD damage to the components. Failure to do so could result in damage to sensitive electronic components and potentially void your warranty.

---

## Re-install the PFUs

- 
- Step 1** At the front of the chassis, locate the PFU bays at the top of the chassis.
- Step 2** Slide a PFU into the left bay (Power A).
- Step 3** Push the handle on the PFU upward to firmly seat the unit into the power plane connectors. **It will take considerable force to move the handle upward and seat the PFU into the power plane connectors.**
- Step 4** Use a Phillips #2 screwdriver to tighten each of the four screws on the PFU to secure it to the chassis.
- Step 5** Re-install the second PFU in the right bay (Power B) by repeating step 2 through step 4.
-

## Re-install the Front Fan Trays

### Lower Front Fan Tray

- 
- Step 1** At the front of the chassis, align the fan tray within the lower chassis opening. With the unit resting on the bottom rail of the opening, push inward until it is seated in the midplane.
- Step 2** Use a #1 Phillips screwdriver to tighten the two captive screws that secure the fan tray to the chassis.
- Step 3** Reinstall the lower access cover.
- 

### Upper Front Fan Tray

- 
- Step 1** Align the fan tray within the upper chassis opening. With the unit resting on the bottom rail of the opening, push inward until it is seated in the midplane.
- Step 2** Use a #1 Phillips screwdriver to tighten the two captive screws that secure the fan tray to the chassis.
- Step 3** Reinstall the upper access cover.
- 

## Re-install the Rear Fan Trays

### Lower Rear Fan Tray

- 
- Step 1** At the rear of the chassis, align the fan tray within the opening at the bottom rear of the chassis.
- Step 2** With the unit resting on the bottom rail of the opening, slowly slide the fan tray into the chassis along the guides until it is seated firmly in the midplane connectors.
- Step 3** Reinstall the lower access cover.
-

## Upper Rear Fan Tray

- 
- Step 1** Align the fan tray within the opening at the upper rear of the chassis.
  - Step 2** With the unit resting on the bottom rail of the opening, slowly slide the fan tray into the chassis along the guides until it is seated firmly in the midplane connectors.
  - Step 3** Reinstall the upper access cover.
- 

## Re-install the Chassis Cover Panels

### Front of Chassis

- 
- Step 1** Reinstall the top cover panel by aligning the cover over the balled posts on the fan tray access panel and above the PDF bays. Push inwards to snap it in place.
  - Step 2** Reinstall the bottom cover panel by aligning the cover over the balled posts on the fan tray access panel and below the air intake panel. Push inwards to snap it in place.
- 

### Rear of Chassis

- 
- Step 1** Reinstall the top cover panel by aligning the cover over the balled posts on the fan tray access panel. Push inwards to snap it in place.
  - Step 2** Reinstall the bottom cover panel by aligning the cover over the balled posts on the fan tray access panel and below the ground terminals. Push inwards to snap it in place.
- 

## Cable Management System

The ASR 5500 chassis ships with a cable management tray. This tray can be used in conjunction with cable management brackets that mount on the MIO/UMIO cards to route and secure network cables to interface ports.



---

**Important**

Installation of the cable management system is optional.

---

Refer to the *Cable Management System Installation* appendix for additional information.





## Card Installation

This chapter describes how to install circuit cards and baffles in the ASR 5500 chassis.

It includes the following sections:

- [Card Slot Assignments, page 49](#)
- [General Installation Sequence, page 51](#)
- [Card Interlock Switch, page 52](#)
- [Circuit Cards, page 53](#)
- [Baffles, page 55](#)
- [Save Shipping Cartons, page 57](#)

## Card Slot Assignments

The tables below show recommended card slot assignments for typical installation scenarios. The recommended card assignments are based on the multiple power planes sourcing power to the card slots. Refer to the *Power Planes* section of the *Power Cabling* chapter for additional information.

Following the recommendations preserves redundant operation if input power is lost to one or more of the power circuits on the PFUs.



### Note

The following tables do not reflect the scenario in which demux capability is enabled on the MIO. With the *Demux on MIO* feature enabled, configurations consisting of 2 Active + 1 Standby DPCs are supported. Refer to the *Configuring a Demux Card* section in the *ASR 5500 System Administration Guide* for important information on the limitations around the use of this feature.

**Table 7: ASR 5500 Chassis Card Slot Assignments (prior to StarOS 18.0)**

Slot	Card Sequence	Requirement
Rear of Chassis		

Slot	Card Sequence	Requirement
1	DPC-5 or UDPC-5	Available
2	DPC-3 or UDPC-3	Required for all systems
3	DPC-1 or UDPC-1	Required for all systems
4	DPC-7 or UDPC-7	Available
5	MIO-1 or UMIO-1	Required for all systems
6	MIO-2 or UMIO-2	Required for all systems
7	DPC-8 or UDPC-8	Available
8	DPC-2 or UDPC-2	Required for all systems
9	DPC-4 or UDPC-4	Required for all systems
10	DPC-6 or UDPC-6	Available
<b>Front of Chassis</b>		
11	SSC-2	Required for all systems
12	SSC-1	Required for all systems
13	FSC-6	Available
14	FSC-4	Required for all systems
15	FSC-2	Required for all systems
16	FSC-3	Required for all systems
17	FSC-1	Required for all systems
18	FSC-5	Available
19	Reserved	
20	Reserved	

**Table 8: ASR 5500 Chassis Card Slot Assignments (StarOS 18 and higher)**

Slot	Card Sequence	Requirement
<b>Rear of Chassis</b>		
1	DPC-5 or UDPC-5	DPC2-5 or UDPC2-5 Available
2	DPC-3 or UDPC-3	DPC2-3 or UDPC2-3 Required for all systems
3	DPC-1 or UDPC-1	DPC2-1 or UDPC2-1 Required for all systems
4	DPC-7 or UDPC-7	DPC2-7 or UDPC2-7 Available
5	MIO-1 or UMIO-1	Required for all systems

Slot	Card Sequence		Requirement
6	MIO-2 or UMIO-2		Required for all systems
7	DPC-8 or UDPC-8	DPC2-8 or UDPC2-8	Available
8	DPC-2 or UDPC-2	DPC2-2 or UDPC2-2	Required for all systems
9	DPC-4 or UDPC-4	DPC2-4 or UDPC2-4	Required for all systems
10	DPC-6 or UDPC-6	DPC2-6 or UDPC2-6	Available
<b>Front of Chassis</b>			
11	SSC-2		Required for all systems
12	SSC-1		Required for all systems
13	FSC-6		Available
14	FSC-4		Required for all systems
15	FSC-2		Required for all systems
16	FSC-3		Required for all systems
17	FSC-1		Required for all systems
18	FSC-5		Available
19	Reserved		
20	Reserved		

## General Installation Sequence

Circuit cards and baffles are installed in the ASR 5500 chassis as follows:

- Front circuit cards and baffles are installed from Right to Left. Start at slot 20 and continue to slot 11. Slots 19 and 20 always require baffles.
- Rear circuit cards and baffles are installed from Left to Right. Start at slot 1 and continue to slot 10.

Complete the installation of each card (includes securing the card in the chassis using a Phillips #2 screwdriver before proceeding to the next card.

You can install all circuit cards and then install baffles to cover empty chassis slots. It does not matter whether you install all front cards or all rear cards first.

See the diagram below.

**Figure 10: Installing Circuit Cards and Baffles**

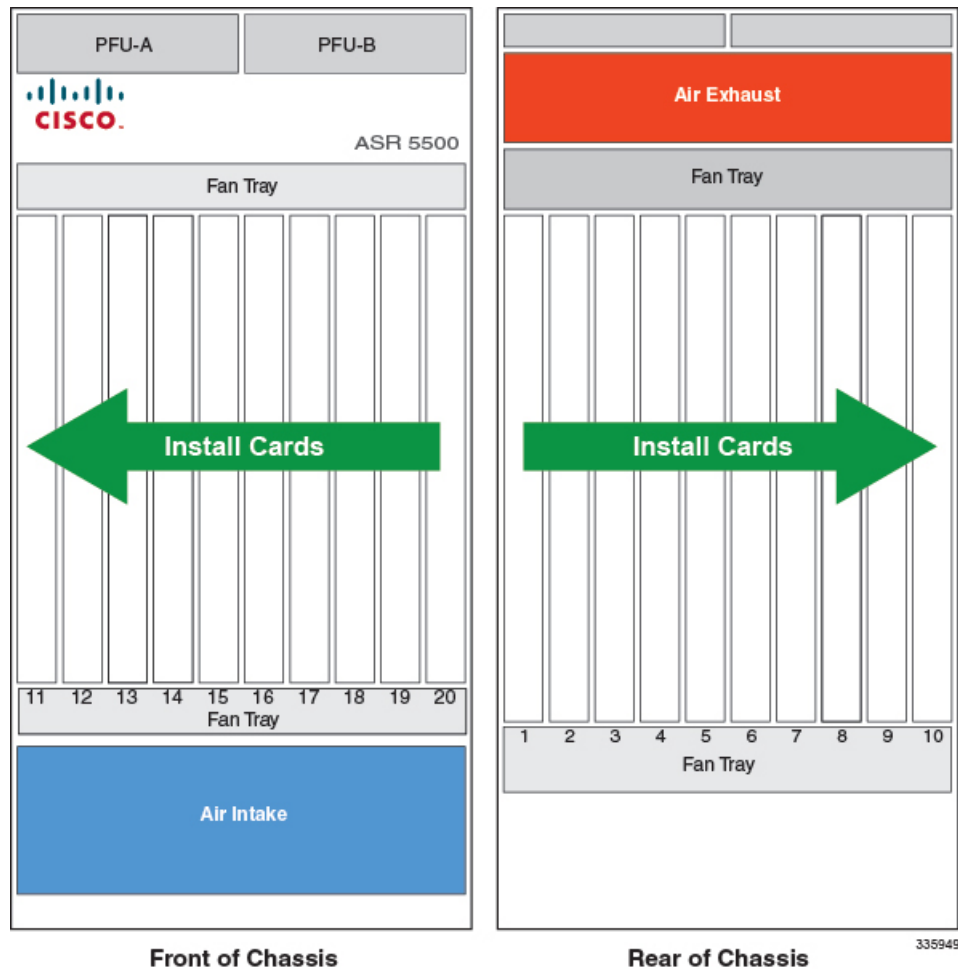

## Card Interlock Switch

Except for rear baffles, ASR 5500 cards include top and bottom ejector handles that incorporate hooks that fit behind the upper and lower rails of the card cage. Lifting the ejector handles outwards ejects the card from the midplane. Pushing the ejector handles inwards seats the card into the midplane.

The top ejector handle incorporates an interlock switch that signals the system that a card is seated in the slot. The blue subhandle must be pushed fully upward to engage the interlock switch. The subhandle also locks

the top ejector handle against the front of the card. Tightening the captive Phillips #2 screw within the top ejector handle secures the subhandle and circuit card to the card cage.

**Figure 11: Card Ejector Handle**

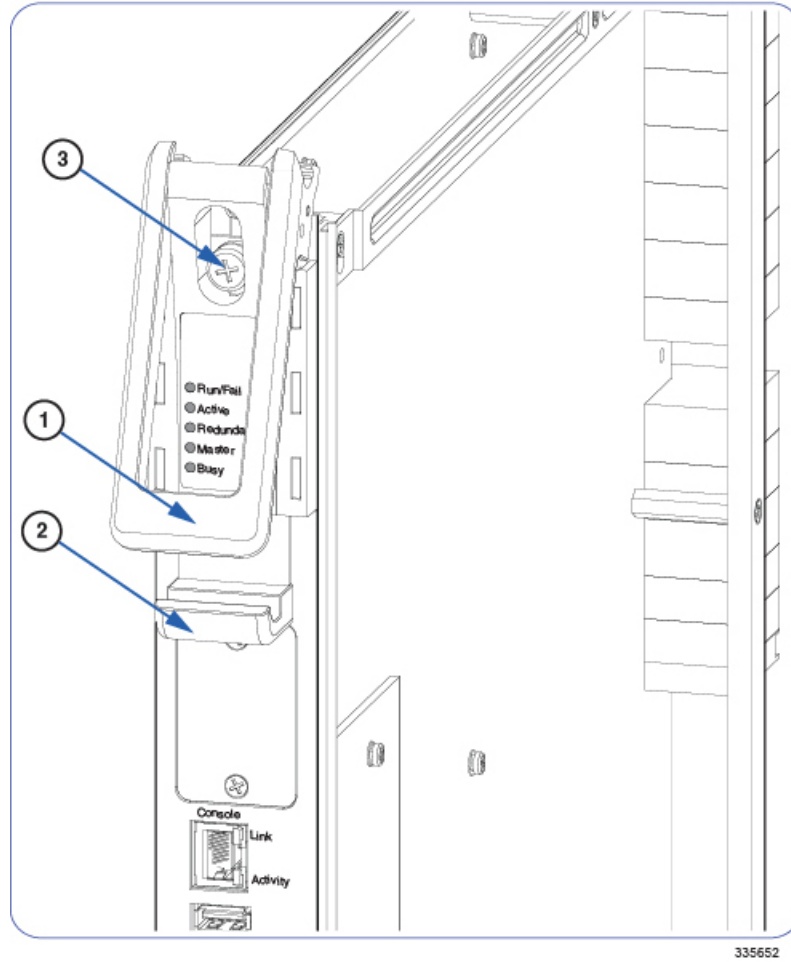

1	Ejector handle	2	Ejector subhandle (interlock)
3	Captive screw (Phillips #2)		

## Circuit Cards

The installation procedure described below is identical for all circuit cards in the chassis. Circuit cards include: SSC, FSC, DPC/UDPC, DPC2/UDP2, MIO/UMIO.

## Prerequisites

**Caution**

During installation, maintenance, and/or removal, wear a grounding wrist strap connected to the ASR 5500 chassis to avoid ESD damage to the components. Failure to do so could result in damage to sensitive electronic components and potentially void your warranty.

**Important**

Save several of the shipping cartons and ESD protective bags for use if a card must be returned to Cisco for fault analysis.

**Important**

On a chassis equipped with the cable management tray, you must lower the tray to insert rear circuit cards. Refer to the *Lowering the Cable Management Tray* section in the *Cable Management System Installation* appendix. The cable management tray can be installed after all rear cards have been installed.

**Important**

Install cable management brackets on MIO cards before inserting the card into the chassis. Refer to the *Installing Cable Management Brackets* section in the *Cable Management System Installation* appendix.

## Installing Circuit Cards

- 
- Step 1** Determine the type of card you are installing. The card type is identified by the label within the bottom ejector handle of the card.
- Step 2** Determine in which chassis slot to install the card based on the information in the tables at the beginning of this chapter.
- Step 3** Install front cards from **Right to Left**. Complete the installation sequence described in Steps 5 through 9 for each card before proceeding to the next card. This includes tightening the captive screws in the ejector handles using a Phillips #2 screwdriver.
- Step 4** Install rear cards from **Left to Right**. Complete the installation sequence described in Steps 5 through 9 for each card before proceeding to the next card. This includes tightening the captive screws in the ejector handles using a Phillips #2 screwdriver.
- Step 5** Position both ejector handles on the circuit card to be up and away (outwards) from the front panel of the card.
- Step 6** Properly support the weight of the card and align it with the upper and lower card guides of the chassis slot. Gently slide the card into the slot until the levers touch the chassis frame.
- Important** When installing cards that contain heat sinks, avoid any contact with an adjacent card. Such contact may loosen a heat sink as the card is being slid into the chassis slot.
- Caution** Never use a cable management bracket on an MIO /UMIO card to lift or insert the card into the chassis. The bracket is not designed to support the weight of the card.

- Step 7** Push both ejector handles inward firmly until the card is seated in the chassis midplane and you cannot push the ejector handles in any further. Press firmly on the card's faceplate to ensure that it is fully seated. The card's front panel should be flush against the chassis' upper and lower card mounts for the slot.
- Step 8** Raise the blue subhandle under the top ejector handle to engage the interlock switch. The subhandle also locks the top ejector handle to the front panel.
- Step 9** To secure the card to the chassis, use a Phillips #2 screwdriver to tighten the captive screws within the top and bottom ejector handles.
- Step 10** Repeat step 1 through step 7 for every card you are installing at the rear and front of the chassis.
- 

## Baffles



**Caution**

---

To ensure proper ventilation, baffles must be used in any chassis slot that is not occupied by a circuit card.

---

Baffles consist of a blank front panel mounted to a formed metal baffle. The baffle slides into the card slots and provides a directed path for air flow. There are two types of baffles – front and rear.

**Figure 12: Front and Rear Baffles**

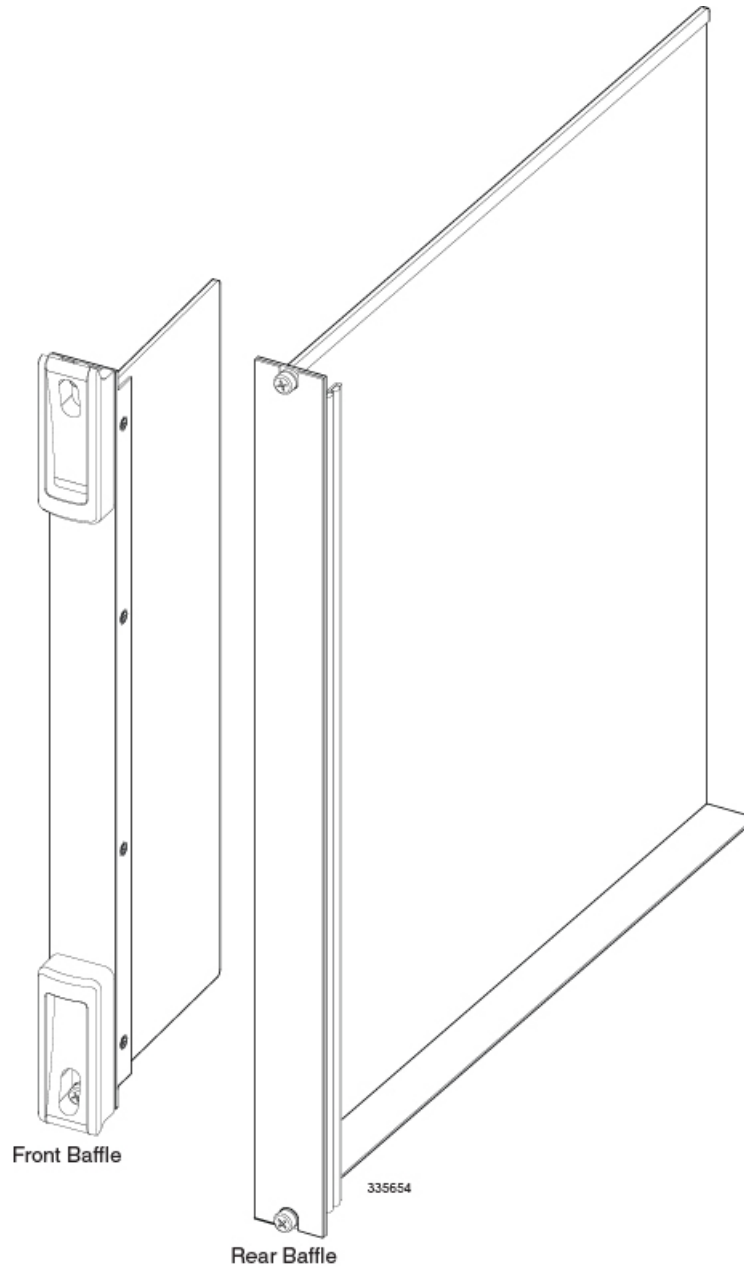



## Installing a Front Baffle

---

- Step 1** Flip both ejector handles outward from the front of the card.
  - Step 2** Install front baffles from **Right to Left**. Complete the installation sequence described in Steps 3 through 6 for each card before proceeding to the next card. This includes tightening the captive screws in the ejector handles using a Phillips #2 screwdriver.
  - Step 3** Align the baffle within an unused chassis slot.
  - Step 4** Slide the card into the slot until its front panel is flush with the upper and lower card rails.
  - Step 5** Push the ejector handles inward until they are flush with the front of the card.
  - Step 6** To secure the card to the chassis, use a Phillips #2 screwdriver to tighten the captive screws within the top and bottom ejector handles.
  - Step 7** Repeat step 1 through step 5 for any additional unused chassis slots.
- 

## Installing a Rear Baffle

---

- Step 1** Install rear baffles from **Left to Right**. Complete the installation sequence described in Steps 2 through 4 for each card before proceeding to the next card. This includes tightening the screws at the top and bottom of the baffle using a Phillips #2 screwdriver.
  - Step 2** Align the baffle within an unused chassis slot.
  - Step 3** Slide the card into the slot until its front panel is flush with the upper and lower card rails.
  - Step 4** To secure the card to the chassis, use a Phillips #2 screwdriver to tighten the captive screws at the top and bottom of the baffle.
  - Step 5** Repeat step 1 through step 3 for any additional unused chassis slots.
- 

## Save Shipping Cartons

Save several of the shipping cartons and protective ESD bags in which the circuit cards were packaged. Use the cartons to package a circuit card for shipment back to Cisco for failure analysis and replacement. For additional information, refer to the *Returning Failed Components* in the *Replacing Components* chapter, and the *RMA Shipping Procedures* appendix.





## MIO Port Cabling

---

This chapter describes how to cable the interface ports on Management I/O (MIO) or Management I/O Universal (UMIO) cards.

It includes the following sections:

- [Interface Ports, page 59](#)
- [Port Status LEDs, page 61](#)
- [Cable Management System, page 62](#)
- [Console Port, page 62](#)
- [Ethernet Management STP Ports, page 66](#)
- [10 GbE Optical Daughter Card Ports, page 67](#)
- [Fiber Optic Bend Radius Guidelines, page 68](#)
- [Fiber Optical Connections, page 70](#)

## Interface Ports

The interface ports are selectively enabled based on their functions in the system – management versus non-management.

## Front Panel Ports

MIO/UMIO cards in slot 5 and slot 6 of the ASR 5500 chassis support the following twisted-pair copper management interface ports:

- one serial Console port (RJ45)
- two 1 Gigabit Ethernet ports (RJ45)

# Daughter Card Ports

MIO/UMIO daughter cards support ten 10 Gigabit Ethernet ports each. The 10 GbE ports connect to other network devices via fiber optic cables that terminate on SFP+ transceivers. These ports support service traffic (non-management).

Figure 13: MIO/UMIO Ports

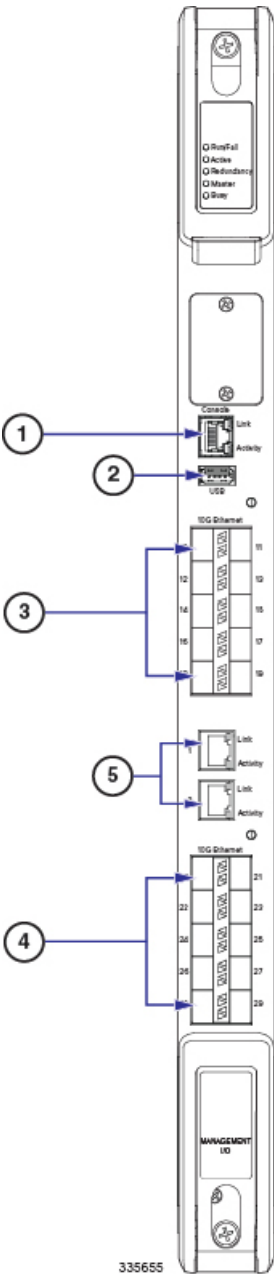

1	Console port [Port 3]	2	USB port
3	10 GbE ports, DC-1 [Ports 10 – 19 ]	4	10 GbE ports, DC-2 [Ports 20 – 29]
5	1 GbE ports (1000Base-T) [Ports 1 and 2]		

## Port Status LEDs

Each of the MIO port interfaces is equipped with two status LEDs:

- **Link:** This green LED shows whether or not the line card is connected to the network. The LED is illuminated when the card is connected.
- **Activity:** This green LED shows when data is transmitted or received. The LED is illuminated or blinks when data is passing through the interface.

Figure 14: Link/Activity LEDs

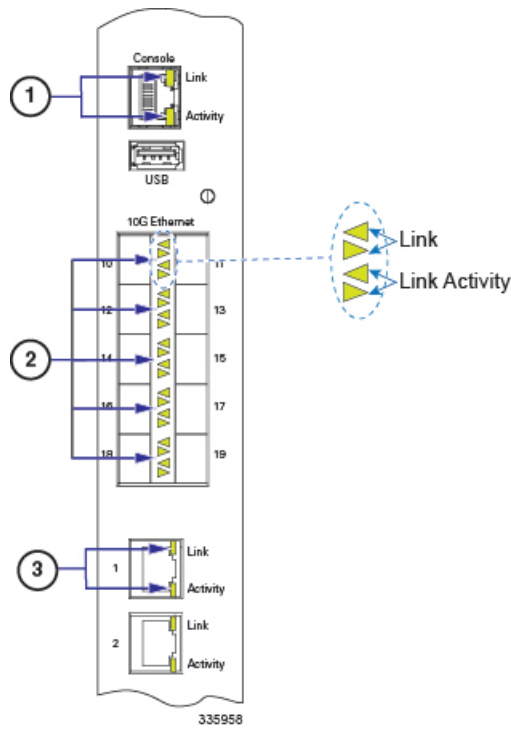

1	Link/Act. LEDs - Console port	2	Link/Act. LEDs - 10 GbE ports
3	Link/Act. LEDs - 1 GbE MGMT ports		

For the 10 GbE ports on each daughter card, the top two LEDs indicate Link status; the left/right arrows indicate for which port. The bottom two LEDs indicate Activity.

# Cable Management System

If you have equipped your ASR 5500 chassis and MIO/UMIO cards with the Cable Management System, refer to the *Routing and Securing Network Cables* section of the *Cable Management System Installation* appendix for additional information.

## Console Port

The Console port (logical Port 3) is an RJ45 RS-232 interface on an MIO or UMIO card that provides access to the command line interface (CLI). The interface communicates at 9600 to 115200 bps; the default is 115,200 bps.



### Important

A connection to the Console port is required if you wish to view boot messages whenever the ASR 5500 chassis is powered up or rebooted. Only the Console port on the Master MIO or UMIO supports logs and CLI sessions. The Console port on the Standby MIO or UMIO is inactive.

## RJ45 Port Pinouts

**Table 9: Console Port RJ45 Serial Pinout**

Pin	Signal Description	Signal Type	Pinout
1	Not connected	—	
2	Not connected	—	
3	Receive Data (RX)	Input	
4	Signal Ground (SGND)	Not applicable	
5	Not connected	—	
6	Transmit Data (TX)	Output	
7	Not connected	—	
8	Not connected	—	



### Important

Hardware flow control is not supported and must be disabled on the connected equipment.

## RJ45 to DB9 Adapter

An RJ45-to-RJ45 serial cable and an RJ45-to-DB9 adapter are supplied with each MIO/UMIO. The DB9 adapter is female. If you use the cable and adapter together, refer to the following figure and table for the cable pinout.

**Figure 15: Console RJ45 Cable and DB9 Adapter**

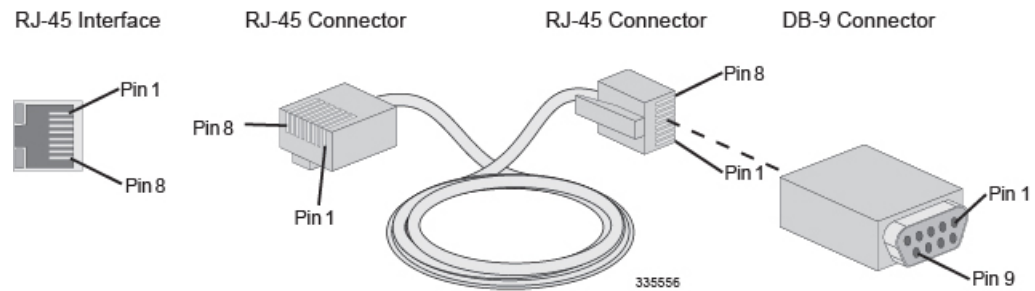

**Table 10: Console RJ45 Cable to DB9Adapter Pinouts**

Signal Description	Signal type	RJ45 Pin	DB9 Pin
Not connected	—	1	7
Not connected	—	2	4
Receive Data (RX)	Input	3	3
Signal Ground (SGND)	Ground	4	5
Not connected	—	5	8
Transmit Data (TX)	Output	6	2
Not connected	—	7	1
Not connected	—	8	6

# USB to DB9 Adapter

A USB to Serial DB9 adapter is supplied with each MIO/UMIO. The DB9 connector on the adapter is male and can be used in conjunction with the Console RJ45 Cable and DB9 Adapter to connect a laptop or workstation to the RJ45 port on the MIO/UMIO.

Figure 16: USB to Serial DB9 Adapter



1	USB 1.1 Type B connector	2	DB9 connector (male)
---	--------------------------	---	----------------------

Table 11: USB to DB9 Adapter - DB9 Pinouts

DB9 Pin	Signal Description	Signal type	Console Port
1	Data Carrier Detect (DCD)	Input	Unused
2	Receive Data (RX)	Input	TX
3	Transmit Data (TX)	Output	RX
4	Data Terminal Ready (DTR)	Output	Unused
5	Signal Ground (SGND)	Ground	Ground
6	Data Set Ready (DSR)	Input	Unused
7	Request To Send (RTS)	Output	Unused
8	Clear To Send (CTS)	Input	Unused
9	Ring Indicator (RI)	Input	Unused



This adapter provides a serial port on a laptop or workstation that does not have one. It draws power from the USB port.

**Figure 17: USB to Console Port Interconnection**

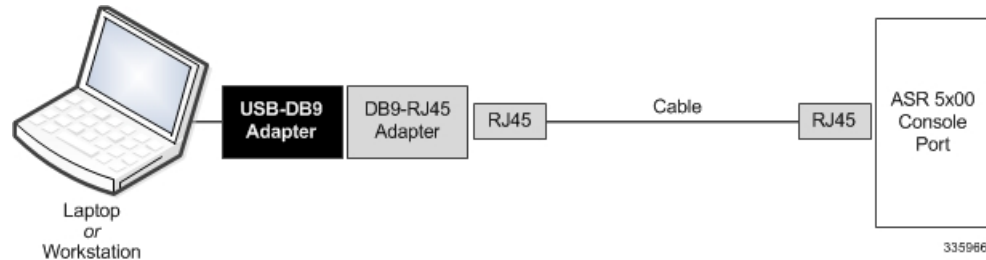

## Connect Console Port to Workstation

You can connect the Console port to a workstation or a laptop with a serial port running a communications application, such as Minicom for Linux® or HyperTerminal® for Windows.

To connect a workstation to the Console port, do the following:

- 
- Step 1** Plug one end of an RJ45 cable to the port labeled Console on the MIO or UMIO.
- Step 2** Plug the other end of the RJ45 cable into the DB9 adapter.
- Step 3** Connect the DB9 end of the adapter into the serial port on the workstation.
- Step 4** Configure the communications application on the workstation to support the following:
- Baud Rate = 115200 bps
  - Data Bits = 8
  - Parity = None
  - Stop Bits = 1
  - Flow Control = None
- 

## Connect Console Port to Terminal Server

You can connect the terminal server to a serial port on a terminal server.



**Important**

The Console port does not support flow control signaling required by some types of terminal servers. Flow control must be disabled on the connected equipment.

---

To connect a terminal server to the Console port, do the following:

- 
- Step 1** Plug one end of an RJ45 cable to the port labeled Console on the MIO or UMIO.
- Step 2** Plug the other end of the RJ45 cable into a port on the terminal server.
- Step 3** Configure the communications protocol on the terminal server port to support the following:
- Baud Rate = 115200 bps
  - Data Bits = 8
  - Parity = None
  - Stop Bits = 1
  - Flow Control = None

**Important** For additional information on connecting the Console port to Cisco servers equipped with asynchronous interface modules, refer to the *Console Port to Cisco Server Cabling* appendix.

---

## Ethernet Management STP Ports

MIOs/UMIOs support two autosensing RJ45 10/100/1000Base-T (IEEE 802.3ab) Ethernet, shielded twisted-pair (STP) copper interfaces (logical Ports 1 and 2) for out-of-band system management access to the CLI.



**Important** To comply with GR-1089 intra-building, lightning-immunity requirements and FCC Radiated Emissions Criteria, you must use STP cable and ensure that it is properly terminated at both ends.

---



**Caution** The 1000Base-T management ports are suitable for connection to intra-building or unexposed wiring or cabling only. These intra-building ports **MUST NOT** be metallically connected to interfaces that connect to the outside plant (OSP) or its wiring. These interfaces are designed for use as intra-building interfaces only (Type 2 or Type 4 ports as described in GR-1089-CORE, Issue 5) and require isolation from the exposed OSP cabling. The addition of Primary Protectors is not sufficient protection in order to connect these interfaces metallically to OSP wiring.

---

The ports support MDI and MDI-X connectors. Ethernet ports normally use MDI connectors and Ethernet ports on a hub normally use MDI-X connectors.

An Ethernet straight-through cable is used to connect an MDI to an MDI-X port. A cross-over cable is used to connect an MDI to an MDI port, or an MDI-X to an MDI-X port.

## RJ45 Port Pinouts

**Table 12: 1000Base-T RJ45 Ethernet Pinouts**

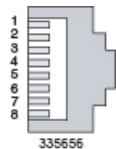
Pin	100Base-T 100Mbps Cat5	1000Base-T 1Gbps Cat5+	Pinout
1	TX+	BI DA+	
2	TX-	BI DA-	
3	RX+	BI DB+	
4	—	BI DC+	
5	—	BI DC-	
6	RX-	BI DB-	
7	—	BI DD+	
8	—	BI DD-	

## Connect 1000Base-T Interface to Network Device



### Important

To facilitate maintenance of the network cabling, the Cat-5 cables should be labeled with terminating destinations.

- Step 1** Insert one end of the Cat-5 cable into the top MGMT connector (Port 1).
- Step 2** Attach the other end of the Cat-5 cable to the appropriate network interface.
- Step 3** Repeat Steps 1 and 2 to connect the bottom MGMT connector (Port 2).

## 10 GbE Optical Daughter Card Ports



### Caution

The 10 Gigabit Ethernet ports on the daughter cards are only certified to work with SFP+ transceivers tested and approved by Cisco. MIO and UMIO cards ship with SFP+ transceivers installed.

The 10 Gigabit Ethernet ports accept the following fiber optic to electrical signal Small Form-Factor Pluggable (SFP+) transceiver types:

- 10GBase-SR – connects the port to a multi-mode fiber optic cable over relatively short distances (30.80 meters).
- 10GBase-LR – connects the port to a single-mode fiber optic cable over a maximum distance of 10km.

The table below lists the signaling parameters supported for the above transceiver types.

**Table 13: SFP+ Transceiver Parameters**

SFP+ Transceiver Type	Parameter	Value
10GBase-SR	Maximum transmit level	-1.0dBm
	Minimum transmit level	-7.3dBm
	Maximum receive level	-1.0 dBm (saturation average power)
	Minimum receive level	-11.1 (sensitivity average power)
10GBase-LR	Maximum transmit level	0.5 dBm
	Minimum transmit level	-8.2 dBm
	Maximum receive level	0.5 dBm (saturation average power)
	Minimum receive level	-12.6 (sensitivity average power)

## Fiber Optic Bend Radius Guidelines

When a fiber cable is bent excessively, the optical signal within the cable may refract and escape through the fiber cladding. Bending can also permanently damage the fiber by causing micro cracks, especially during cable installation due to pulling forces. The result is known as bend loss: a loss of signal strength that may compromise the integrity of the data transmission.



### Caution

To avoid damaging the fiber optic cable, the cable connector, or the optical interface, do not install or remove fiber optic transceivers with fiber-optic cables attached. Disconnect all cables before removing or installing a transceiver.

## Recommended Bend Radius

ANSI/TIA/EIA-568B.3, "Optical Fiber Cabling Components Standard," specifies minimum bend radius standards and maximum pulling tensions for 50/125-micron and 62.5/125-micron fiber-optic cables. Those recommendations include:

- 1 inch (2.54cm) under no pull load.
- 2 inches (5.08cm) when subject to tensile loading up to the rated limit.

For inside plant cable other than two- and four-fiber, the standard specifies:

- 10 times the cable's outside diameter under no pull load
- 15 times the cable's outside diameter when subject to tensile load.

There are two types of bend radii:

- The dynamic bend radius is the tightest recommended bend while installing cable at the maximum rated tension. It is the larger of the two specified bend radii (see figure below). Throughout the pull, the minimum bend radius must be strictly followed. If a location exists in the middle of a run where a relatively tight bend is unavoidable, the cable should be hand-fed around the bend or a pulley can be used.
- The static bend radius is the tightest recommended bend while the cable is under a minimum tension. It is the smaller of the two specified bend radii. After the pull is complete, the cable can be bent more tightly to fit into existing space, but not to exceed the long term minimum bend radius.

Always follow the manufacturer's guidelines for minimum bend radius and tension. Failure to do so may result in high attenuation (macrobends) and possible damage to the cable and fiber. Guidelines are normally supplied with the cable manufacturer specification sheets. If the bend radius specifications are unknown, the recommendation is to maintain a minimum radius of 20 times the diameter of the cable.

**Figure 18: Recommended Fiber Optic Bend Radii**

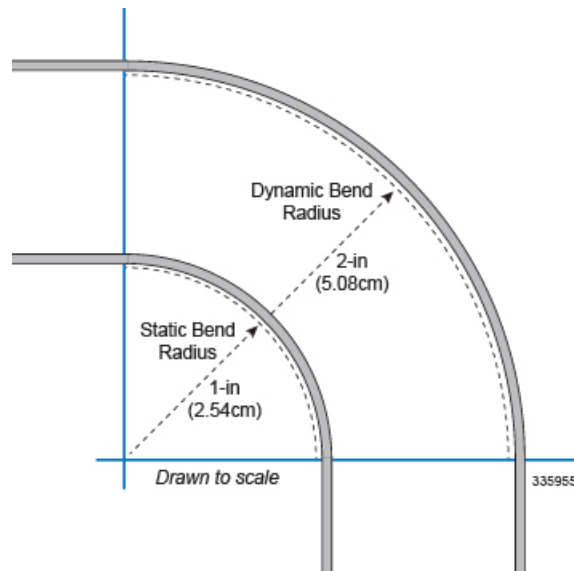

## Bend-Insensitive Multimode Fiber

An alternative for maintaining tighter than recommended bend radii is use of Bend-Insensitive Multimode Fiber (BIMMF). BIMMF is more impervious to bend loss than standard 50-micron multimode fiber (MMF) cable.



### Important

BIMMF cables are only optimized for 850nm wavelengths and not for 1300nm wavelengths.

BIMMF is structurally the same as standard MMF cable but there is an added layer of glass between the core and the cladding. This layer of glass has a much lower refractive index than the cladding.

Bend-insensitive 50-micron MMF cable is full backwards compatible with existing 50-micron MMF and fully compliant with OM2, OM3 and OM4 standards.

## Fiber Optical Connections



### Caution

The SFP+ transceiver modules are static sensitive devices. Always use an ESD wrist strap or similar individual grounding device when coming into contact with SFP+ modules.



### Caution

Before connecting fiber optic cables, press each module into the slot firmly with your thumb to reseal them.

## Removing Dust Plugs

Before removing the dust plugs and making any optical connections, observe the following guidelines:

- Always keep the protective dust plugs on the unplugged fiber-optic cable connectors and the transceiver optical bores until you are ready to make a connection.
- Always inspect and clean the LC connector end-faces just before making any connections. See [Cleaning Fiber Optic Connectors](#), on page 71.
- Always grasp the LC connector housing to plug or unplug a fiber-optic cable.



### Important

To facilitate maintenance of the network cabling, all fiber optic cables should be labeled with terminating destinations.

## Connecting Fiber Optic Cables

- 
- Step 1** Remove the dust plug from the network interface LC connector of the SFP+ module. Save the dust plug for future use.
  - Step 2** Inspect and clean the LC connector's fiber-optic end-faces.
  - Step 3** Insert the duplex LC/PC connector on the network cable into the duplex port on the module.
  - Step 4** Attach the other end of the network fiber-optic cable to the network device that you want to connect.
  - Step 5** Repeat Step 1 through Step 4 for the remaining ports on the daughter card.
  - Step 6** Repeat Step 1 through Step 4 for ports on the second DC.
-

## Cleaning Fiber Optic Connectors

Fiber optic connectors join optical fibers together. They can be damaged by improper cleaning and connection procedures. Dirty or damaged fiber optic connectors can degrade communication.

In a fiber optic system, light is transmitted through extremely small fiber cores. Because fiber cores are often 62.5 microns or less in diameter, and dust particles range from a tenth of a micron to several microns in diameter, dust and any other contamination at the end of the fiber core can degrade the performance of the connector interface where the cores meet. Therefore, the connector must be precisely aligned and the connector interface must be absolutely free of foreign material.

Connector loss, or insertion loss, is a critical performance characteristic of a fiber optic connector. Return loss is also an important factor. Return loss specifies the amount of reflected light: the lower the reflection, the better the connection. The best physical contact connectors have return losses of better than  $-40$  dB, but  $-20$  to  $-30$  dB is more common.

The connection quality depends on two factors: the type of connector and the proper cleaning and connection techniques. Dirty fiber connectors are a common source of light loss. Keep the connectors clean at all times, and keep the dust plugs or covers installed when the connectors are not in use.

As a general rule, any time you detect a significant, unexplained loss of light, clean the connectors. To clean the optical connectors, obtain and use a fiber optic cleaning kit and follow the manufacturer's usage instructions. Clean the ferrule, the protective tube or cone that surrounds the fiber core, and the end-face surface of the fiber core.

If a cleaning kit is not available, follow these steps:

- 1 Use a lint-free tissue soaked in 99 percent pure isopropyl alcohol and gently wipe the end-face of the fiber core. Wait for five seconds for the surfaces to dry and wipe the surfaces a second time.
- 2 Use clean, dry, oil-free compressed air to remove any residual dust from the connector.
- 3 Use a magnifying glass or inspection microscope to inspect the ferrule at angle. Do not look directly into the aperture. If you detect any contamination, repeat Steps 1 and 2.

**Caution**

---

Because invisible laser radiation may be emitted from the aperture of the port when no cable is connected, avoid exposure to laser radiation and do not stare into open apertures.

---







## SSC Alarm Cabling

This chapter describes how to cable the alarm contacts on the System Status Card (SSC).



### Caution

The CO alarm interface of the SSC is suitable for connection to intra-building or unexposed wiring or cabling only. This interface **MUST NOT** be metallically connected to interfaces that connect to the outside plant (OSP) or its wiring. This interface is designed for use as an intra-building interface only (Type 2 or Type 4 ports as described in GR-1089-CORE, Issue 5) and requires isolation from the exposed OSP cabling. The addition of Primary Protectors is not sufficient protection in order to connect these interfaces metallically to OSP wiring.

It includes the following sections:

- [CO Alarm Interface, page 73](#)
- [Alarm Cutoff \(ACO\), page 74](#)
- [Alarm Connector Pinout, page 75](#)
- [Electrical Characteristics, page 75](#)
- [CO Alarm Wiring Example, page 76](#)

## CO Alarm Interface

The Central Office (CO) Alarm interface on the SSC is a DB15 female connector that supports three low voltage, normally-closed/normally-open dry-contact relays. These Form C relays interface with an CO alarm monitor panel to trigger external audio and/or visual indicators.

Three alarm levels are supported by the relays:

- **Minor Alarm** – This alarm is triggered when a high temperature is detected on a card, causing the fan tray to switch the fans to high speed.
- **Major Alarm** – This alarm is triggered when there is a:
  - Hardware failure that causes the card to be placed in an off-line state
  - PFU failure or removal from the chassis

- Failure of one or more fans on any of the upper or lower fan tray units
- Fan tray failure or any fan tray unit is removed from the chassis
- **Critical Alarm** – This alarm is triggered when a degradation in service is detected. For example, if the system is supporting a large number of subscribers and DPCs are removed, the amount of available CPU and memory resources available for use are reduced.

## Alarm Cutoff (ACO)

The front panel of the SSC includes an audible system alarm and an Alarm Cutoff (ACO) switch. Press and release this switch to reset the system alarm speaker.

**Figure 19: SSC CO Alarm Interface**

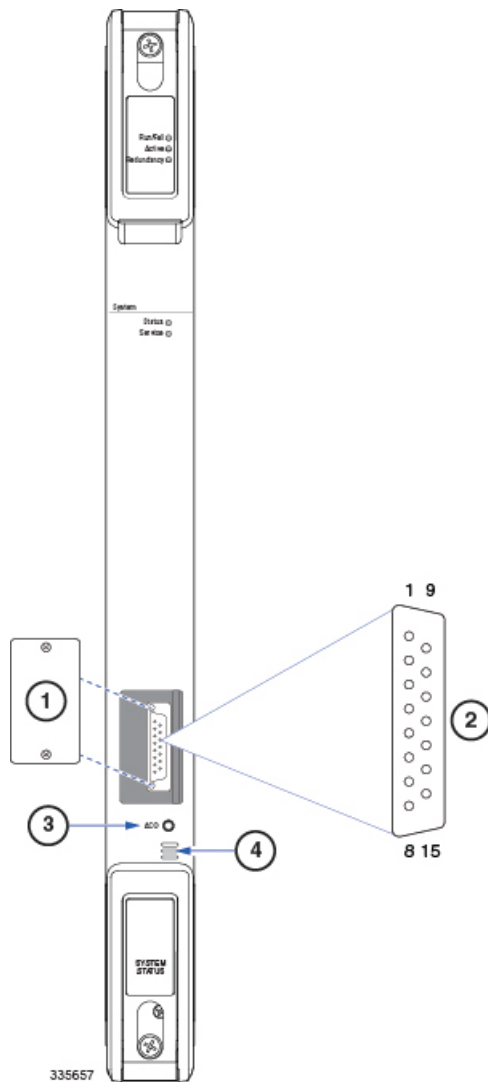

1	Connector cover plate	2	CO alarm interface (DB15)
3	Alarm Cutoff (ACO) switch	4	Audible alarm

## Alarm Connector Pinout

The CO alarm connector pinout is provided in the table below.

Use a Phillips #1 screwdriver to remove the two screws that secure the cover plate over the alarm connector.

**Table 14: DB15S CO Alarm Connector Pinout**

Pin	Alarm Level	Signal
1	Minor	Normally Open
2		Normally Closed
3	—	Not connected
4	Major	Normally Open
5		Normally Closed
6	—	Not connected
7	Critical	Normally Open
8		Normally Closed
9	Minor	Minor, Common
10	—	Not connected
11	—	Not connected
12	Major	Major, Common
13	—	Not connected
14	—	Not connected
15	Critical	Critical, Common

## Electrical Characteristics

Each of the three dry-contact, Form C relay switches is rated to support a maximum switching current of 1A@30VDC.

  
**Caution**

Never connect a high voltage/high current device such as an audible alarm/siren or incandescent lamp directly to the EO alarm connector.

## CO Alarm Wiring Example

The figure below depicts how the three dry-contact (no voltage supplied) relay contacts can each control up to two alarming devices. In this example the SSC CO alarm interface is connected to a CO Alarm Panel, where green LEDs are wired to indicate normal operation, and red LEDs are wired to indicate alarm conditions.

With all relays de-energized, the green LEDs are illuminated. If an alarm relay is energized, its NO (normally open) contact closes; the green LED is extinguished and the red LED is illuminated.

**Figure 20: CO Alarm Interface Schematic**

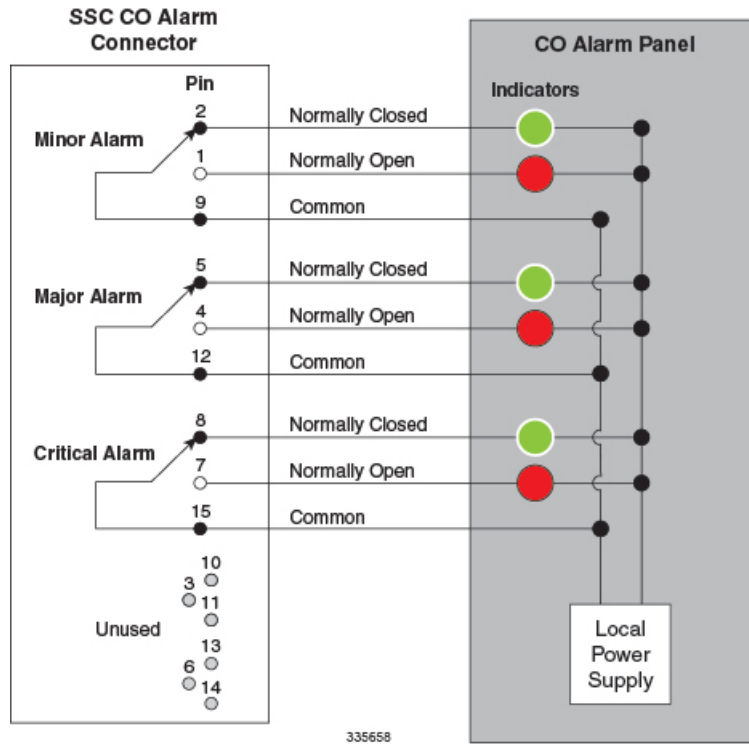



## CHAPTER

# 8

## Power Cabling

---

This chapter describes how to connect -48 VDC power feeds to the Power Filter Units (PFUs) on the ASR 5500 chassis.



### Important

The -48 VDC Battery Return (BR) input terminals to the PFUs are not connected to the equipment frame (chassis) are treated as Isolated DC returns (DC-I) in compliance with GR-1089-CORE (sec.9.8.3).

This chapter includes the following sections:

- [Power Considerations, page 77](#)
- [Internal Power Planes, page 78](#)
- [Power Cable Requirements, page 81](#)
- [Connect Power Feeds to the PFUs, page 83](#)

## Power Considerations

Each chassis supports up to eight -48 VDC, 80-amp power feeds, four per PFU. Each feed consists of a supply and return cable.



### Important

The power source must be a UL/CSA listed device with a regulated output no greater than -60VDC.

Typically, the DC power feeds are fed from a power distribution frame (PDF) to a power distribution panel (PDP) at the rack.



### Important

The DC power Battery Return (BR) or positive terminal, must be grounded at the source end (power feed or mains power end).

**Important**

Minimum 4 AWG multiple strand, high-flex cable is recommended for final connections from the PDP to the PFUs. Although the chassis configuration may not draw maximum power, it should be sized and wired to handle 12.8 kW of power to accommodate future expansion. See [Power Cable Requirements, on page 81](#).

Each feed connects to supply and return terminals on the rear of the PFUs using two-hole lugs crimped to the end of each cable. The feed cables are routed through openings in each side of the chassis. The input terminals are wired through EMI filters to the ASR 5500 backplane.

For a non-redundant chassis power configuration, live power feeds must be connected to all four power inputs on PFU-A. For a redundant power configuration, live power feeds must be connected to all four power inputs on PFU-B. The four power feeds per PFU assure that all power planes in the backplane are energized; power is available to all card slots in the chassis. For additional information, see [Internal Power Planes, on page 78](#).

The circuit breakers at the power distribution panel must disconnect the supply line of each -48VDC feed. However, it is recommended that the circuit breakers at the power distribution panel simultaneously disconnect both poles (supply and return) for each -48 VDC feed to completely isolate the ASR 5500 from the power source.

To maintain power redundancy, separate -48 VDC supply circuits should be used to feed each DC power input on both PFUs.

**Caution**

Set the circuit breakers on the distribution panel to the OFF position before making the power connections at the PFUs.

Each power input cable must be terminated with a supplied Panduit LCD4-14AF-L 2-hole, 90-degree lug using the appropriate crimping tool and die.

The following alternate lug types (not supplied with the chassis) are also approved for use on the power feeds:

- Panduit LCC4-14AF-L, 4 AWG, 2-hole, 90-degree long barrel lug
- Burndy YAZ2C2TC1490, 2 AWG, 2-hole, 90-degree long barrel lug

If a DC power input should fail, the operating supply circuits continue to power the ASR 5500.

## Internal Power Planes

Four inputs are labeled A1 through A4 and the other inputs are labeled B1 through B4. A1 is redundant for B1 and so on. The inputs correspond to the four power planes that supply power to various chassis components as shown in the table and figure below.

The SSC monitors all eight feeds for outages.

**Important**

All four power inputs on a PFU must be connected to live power feeds to assure that all card slots in the ASR 5500 chassis are energized.

## Chassis Power Card Slot Allocations

**Table 15: Chassis Power Planes**

Card Type	Slot	Plane 1	Plane 2	Plane 3	Plane 4
<b>Rear Cards</b>					
DPC or UDPC, DPC2	1	—	—	—	Yes
DPC or UDPC, DPC2 or UDPC2	2	—	—	—	Yes
DPC or UDPC, DPC2 or UDPC2	3	—	—	—	Yes
DPC or UDPC, DPC2 or UDPC2	4	—	Yes	—	—
MIO or UMIO	5	—	Yes	—	—
MIO or UMIO	6	—	—	Yes	—
DPC or UDPC, DPC2 or UDPC2	7	—	—	Yes	—
DPC or UDPC, DPC2 or UDPC2	8	Yes	—	—	—
DPC or UDPC, DPC2 or UDPC2	9	Yes	—	—	—
DPC or UDPC, DPC2 or UDPC2	10	Yes	—	—	—
<b>Front Cards</b>					
SSC	11	—	Yes	—	—
SSC	12	—	Yes	—	—
FSC	13	Yes	—	—	—
FSC	14	—	—	Yes	—
FSC	15	—	—	Yes	—
FSC	16	—	Yes	—	—
FSC	17	—	Yes	—	—
FSC	18	—	—	—	Yes
Reserved	19	—	—	Yes	—
Reserved	20	—	—	Yes	—

Card Type	Slot	Plane 1	Plane 2	Plane 3	Plane 4
<b>Fan Trays</b>					
Upper	Top	—	—	Yes	—
Lower	Bottom	—	Yes	—	—

**Figure 21: PFU Redundant Power Planes**

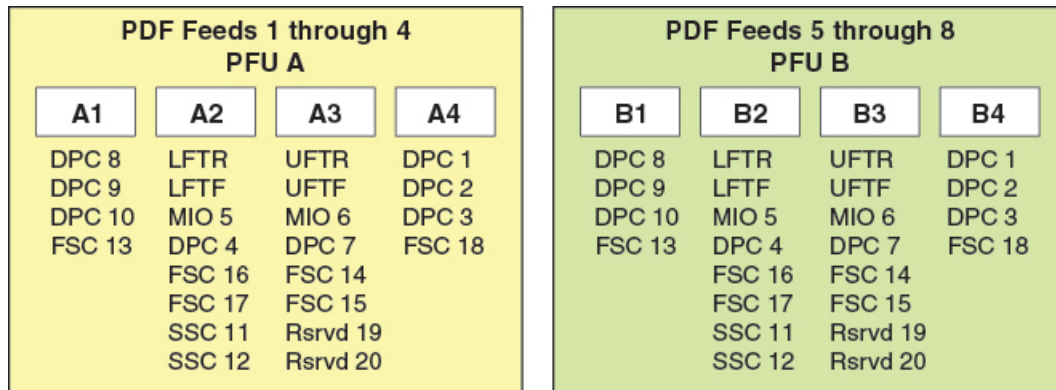

335659

Legend	Description
DPC	DPC/UDPC or DPC2/UDPC2
LFTR	Lower Fan Tray Rear
LFTF	Lower Fan Tray Front
MIO	MIO/UMIO
UFTR	Upper Fan Tray Rear
UFTF	Upper Fan Tray Front

## Power Feed Connections

The figure below shows a recommended method for connecting -48 VDC power feeds from the power distribution frame (PDF) through a power distribution panel (PDP) to the power filter units (PFUs) on the ASR 5500 chassis.



This method preserves electrical redundancy from the PDF to the PFUs.

**Figure 22: Power Feeds to the ASR 5500 Chassis**

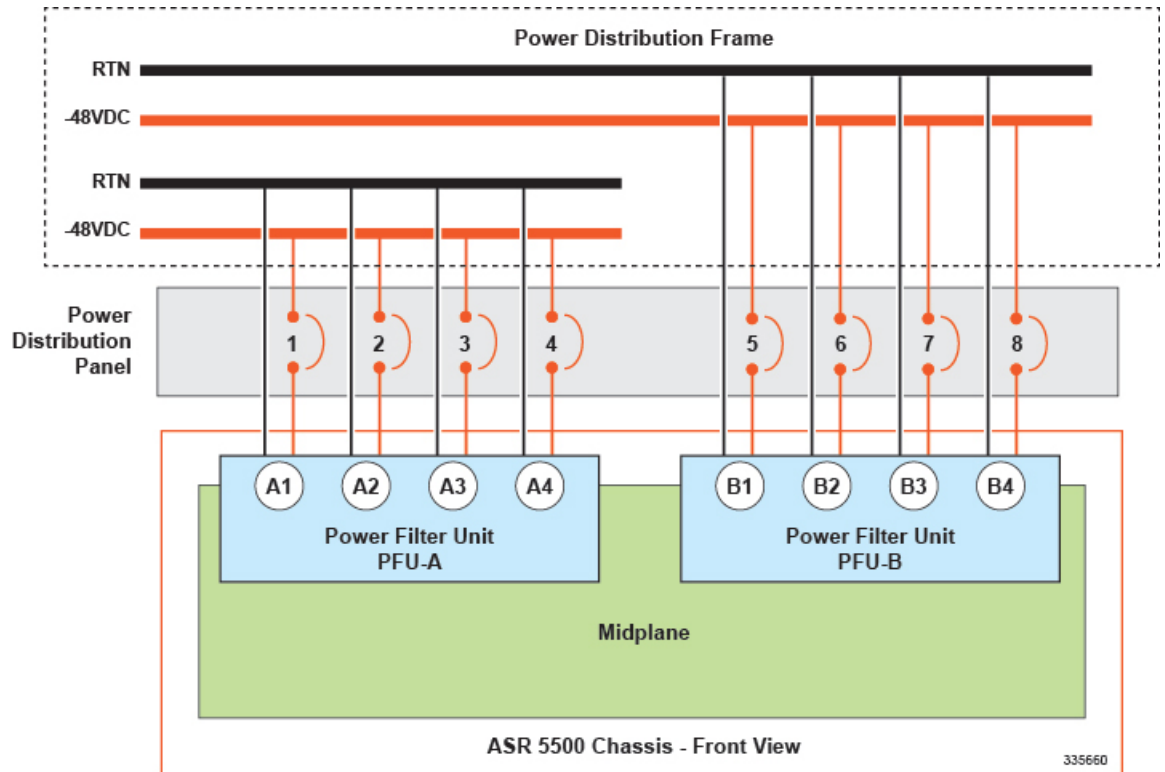

## Power Cable Requirements

### Sizing Power Cables

The following guidelines should be adhered to when sizing cable gauges for connecting the PFUs to a rack-mounted power distribution panel.

- Each conductor between the PDF and PDP should be calculated assuming a 0.3 volt drop from the PDF to the panel.
- Each cable between the PDP and ASR 5500 PFUs should be calculated a 0.3 volt drop from the panel to the chassis. This is a total voltage drop of 0.6 volts.
- Use high-flex, multiple-strand cable (minimum 4 AWG) between the power distribution panel and the chassis.

**Important**

Even if the ASR 5500 chassis will not be completely filled with cards, size the cables for maximum power draw according to the above recommendations. This practice facilitates future expansion as more cards are added and the power supply is appropriately incremented.

## Terminating Power Cables

Each cable should be terminated with a 90 degree, 2-hole lug (supplied). Each feed consists of a supply (-48VDC) and return (RTN) cable. The feed cables terminate at the rear of each PFU on 0.25-inch posts spaced 0.63-inch on center.

### Cable Routing

All feed cables must be routed through the openings at the upper rear sides of the chassis.

### Method of Connection

The method of connection at each PFU terminal is: flat washer, lug, lock washer and nut (7/16-inch). The nut(s) must be torqued to 50 in-lb. (5.65 N-m).

### Insulate Lugs

Use heat shrink tubing or non-conductive tape to insulate much of the exposed metal on the lug without interfering with the attachment point.

### Crimp Lugs on Cables

Use the Panduit® lugs supplied with the chassis (LCD4-14AF-L). The lug must be crimped to the end of a ground cable using Panduit crimp tool part number CT-720-1 (die color: gray, P29). The wire strip length is 7/8-inch (22 mm).

Follow the OEM recommendations for preparing and crimping the lugs on the ends of each feed cable.

### Label All Cables

Label the supply and return cables going to each terminal on the rear of the PFUs. Include the terminal number (A-1 to A4, B1 to B4) and power distribution panel circuit number. This will facilitate troubleshooting, as well as removal and replacement of a failed PFU.

# Connect Power Feeds to the PFUs

**Caution**  To avoid personal injury or possible equipment damage, ensure that the circuit breakers for all ASR 5500 chassis feeds from the power distribution panel are all set to OFF before attempting to attach power cables to the PFU(s).

**Caution**  Verify that all circuit breakers on the front panels of both PFUs (four per PFU) are set to OFF before attaching power feed cables to the PFUs (see figure below). The breakers must remain OFF until the chassis is to be powered up.

**Figure 23: PFU Front Panel**

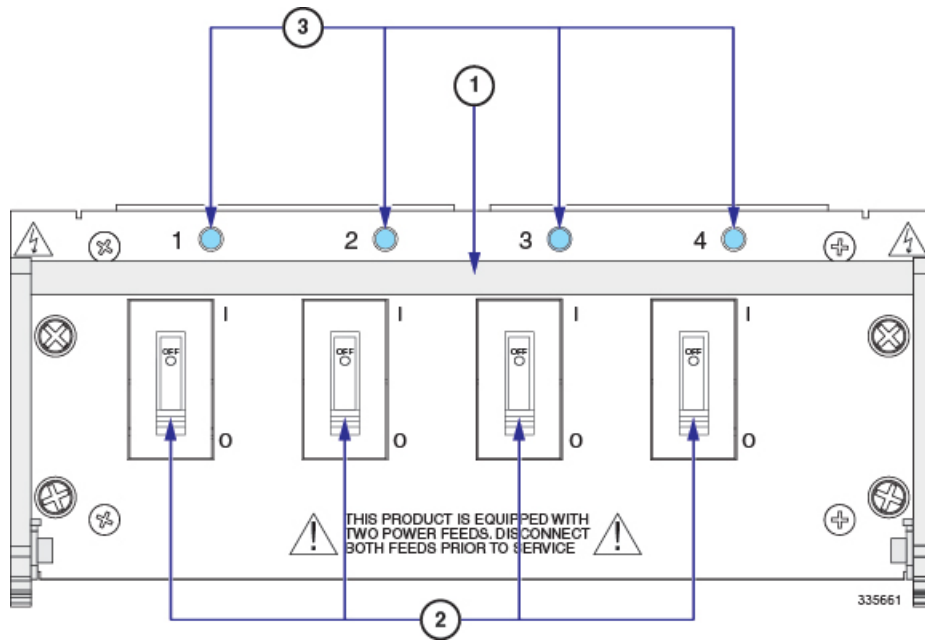

1	Handle	2	Circuit breaker
3	Blue LED		

**Important**

The eight power terminals on the back of each PFU are shipped with nuts and washers attached.

- 
- Step 1** Remove the plastic power input cover from the top-rear of the ASR 5500 chassis. Use a Phillips #2 head screw driver to loosen the two captive screws securing the cover to the chassis. Removing this cover exposes the power feed terminals at the rear of the PFUs.
- Step 2** Remove one nut, a lock washer and a flat washer from each of the eight terminals; leave the bottom nut on each terminal. The nuts on the PFU terminals require a 7/16-inch nut driver or socket wrench for removal.
- Step 3** Before proceeding, verify that the bottom nuts on all terminals are torqued to 50 in-lb. (5.65 N-m).
- Step 4** Slide a 1.25 in. (3.2 cm) length of heat shrink tubing over the end of each feed cable. You can skip this step if you choose to use non-conductive tape to insulate the crimp portion of the 2-hole lug.
- Step 5** Crimp a 2-hole 90o lug to each -48 VDC and Return cable.
- Step 6** Slide the heat shrink tubing over the crimp portion of the lug until it contacts the flat attachment point. Use a heat source to warm the tubing until it tightly wraps the metal. Alternatively, you can firmly wrap the crimp portion of the lug with a non-conductive tape.
- Step 7** Thread each cable through an opening in the side of the chassis and route it to the appropriate terminal (-48V 1, Return 1, -48V 2, Return 2, etc.). Rectangular openings are provided at the sides of the chassis for this purpose. See the figure below.
- Caution** Do not route any cables through openings in the plastic power input cover. The openings are for air flow only.
- Step 8** Install each lug over the two terminals.
- Step 9** Secure each lug to the terminals with flat washers, lock washers and nuts. Tighten the nuts while holding the lug perpendicular to the attachment studs and maintaining as much separation as possible with adjacent cables. The nuts should be torqued to 50 in-lb. (5.65 N-m).
- Important** The supply and return lugs for each power feed will be separated by the ridge in the insulating spacer shown in Detail A of the figure below.
- After all feeds are attached, move/push all cables to verify there are no potential shorts.
- Caution** To avoid the risk of fire, take proper precautions to ensure that the power supply and return lugs are not touching.
- Step 10** Continue installing the feeds on the terminals until all power feed connections have been completed to both PFUs.
- Step 11** Reinstall the plastic terminal cover on the top-rear of the chassis.
- Caution** To avoid the risk of personal injury and/or potential damage to the system, never operate the chassis without the power input cover.

**Step 12** Proceed to the *System Power-up* chapter for information and instructions on applying power to the chassis and verifying that the installation was successful.

**Figure 24: PFU Rear Power Connections**

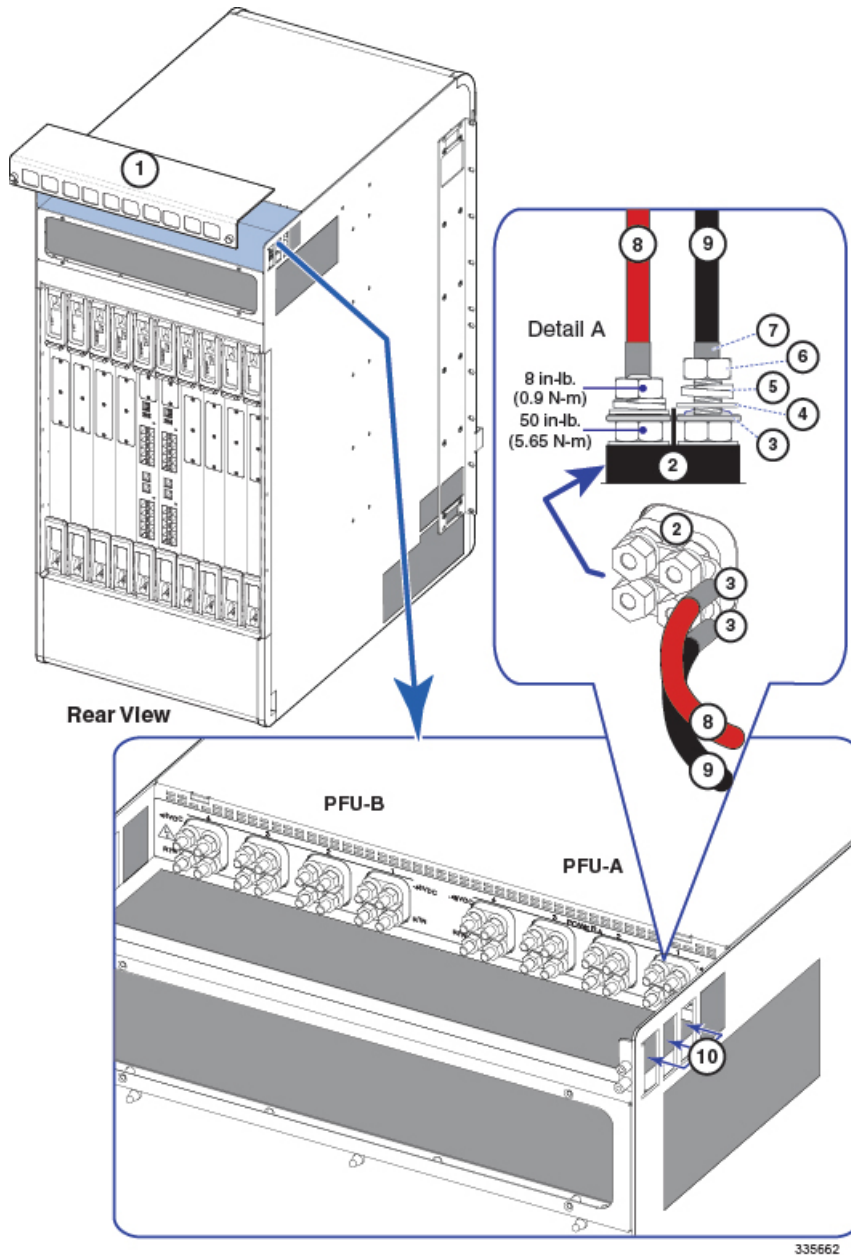

1	Power input cover	2	Insulating spacer
---	-------------------	---	-------------------

3	2-hole, 90° lug	4	Flat washer
5	Lock washer	6	7/16-inch hex nut
7	Non-conductive wrap	8	-48VDC Supply cable
9	-48VDC return cable	10	Cable access opening

---



## System Power-up

This chapter describes the boot process that occurs when the system is first powered up.



### Important

The system boot process is governed by StarOS licenses. Refer to *Chassis Universal License Requirements* for additional information on the effect licenses and card types have on the boot process.

This chapter includes the following sections:

- [System Boot Process, page 87](#)
- [Applying Power to the Chassis, page 88](#)
- [Verifying System Startup, page 89](#)

## System Boot Process

The boot process is initiated after power is applied to the chassis.

- Step 1** When power is first applied to the chassis, the MIO/UMIOs in slots 5 and 6 and all fan trays are the first to receive power. Once the software is running, power is then quickly applied to the remaining cards in the system.
- Important** The fans in the fan trays initially rotate at medium speed until the first MIO completes its boot up. If no MIO/UMIO boots successfully within a few minutes, the fan speed increases to 100%.
- Step 2** During the startup process, each card performs a series of Power-On Self Tests (POSTs) to ensure that the hardware is operational. These tests also verify that the card meets all license requirements to operate on this chassis.
- Step 3** If the MIO/UMIO in slot 5 successfully executes all POSTs, it becomes the active chassis management MIO/UMIO for the system. The MIO/UMIO in slot 6 becomes the standby.
- Important** If the MIO/UMIO in slot 5 fails to boot, the MIO/UMIO in slot 6 automatically becomes the active chassis management MIO.
- Step 4** The active MIO/UMIO begins loading the operating system software image that is designated in the boot stack. The boot stack entries are contained in the boot.sys file that resides on the MIO/UMIO's flash device. The standby MIO/UMIO observes the active card's startup. If the file on the active card is loading normally, the standby MIO/UMIO boots from the active card's image. If the active MIO/UMIO experiences a problem during this phase, the

standby card loads its software image, that is designated by its own boot stack entry in its boot.sys file, and takes control of the system as the active card.

**Step 5** After the software image is loaded into MIO RAM, the active card determines if other cards are installed in the chassis by applying power to the other slots and signaling them. If the chassis slot contains a card, power is left on to that slot. All empty slots are powered off.

**Important** If no MIO/UMIOs are installed in slots 5 and 6 or if they both fail to boot, other cards in the system will not boot.

**Step 6** When power is applied to the other installed cards, they each perform their own series of POSTs.

**Important** After successful completion of the POSTs, each of the data processing cards enter standby mode. Installed DPC/UDPCs or DPC2/UDPC2s remain in standby mode until they are made active via configuration.

**Step 7** After entering the standby mode, each of the DPC/UDPC or DPC2/UDPC2 control processors communicate with the active chassis management MIO to receive the appropriate code.

**Step 8** Upon successful loading of the software image, the system loads a configuration file designated in the boot stack (boot.sys file). If this is the first time the system is powered on and there is no configuration file, the active MIO/UMIO invokes the system's Quick Setup Wizard. Use the Quick Setup Wizard to configure basic system parameters that enable the system to communicate across the management network.

The Wizard creates a configuration file, saved as system.cfg, that can be used as a starting point for subsequent configurations. The system is configured by automatically applying the configuration file during any subsequent boot. After the system successfully boots and the initial configuration is applied, the system is ready to be configured or offer services.

## Applying Power to the Chassis

With all power and ground cables connected, you apply power to the chassis by following the instructions below.



**Caution** Never operate the chassis if any slots are uncovered. This reduces airflow through the chassis and could cause it to overheat. A card or blank panel must be installed in every chassis slot at all times.

- Step 1** If the top-front cover is installed on the chassis, remove the cover to access the PFU circuit breakers.
- Step 2** At the front of the chassis verify that the circuit breakers on the PFUs are in the OFF position.
- Step 3** Set the circuit breakers on the power distribution panel (PDP) to ON.
- Step 4** At the rear of the chassis, remove the plastic terminal cover to access the PFU input terminals.
- Step 5** Use a voltmeter to check the voltage level and polarity across the input terminals for each PFU. The meter should display a voltage approximately equal to that of the power source.
- Step 6** Turn ON all the circuit breakers on both PFUs.
- Step 7** Proceed to [Verifying System Startup](#), on page 89.
- Step 8** When the initial checks are completed, reinstall the covers removed in step 1 and step 4.



## Verifying System Startup

When power is applied to the chassis, power is provided to the upper and lower fan trays, and every installed card.

Light emitting diodes (LEDs) on all circuit cards and daughter cards indicate operating status.



### Important

As the system progresses through its boot process, LED activity will eventually occur on all cards. Allow several minutes to elapse prior to checking the status LEDs on the various cards.

## Checking PFU Status

The blue LEDs above the circuit breakers on each PFU should all be ON.

If all of the LEDs on a PFU are OFF, check the following:

- The PFU is firmly seated in the midplane connectors.
- All circuit breakers on the PFU are set to ON.
- All circuit breakers for power feeds from the local power distribution panel are ON.
- -48 VDC power is available from the PDF to the local PDP.

If any LED is OFF, check the following:

- PFU circuit breaker is ON.
- Voltage is present at corresponding input terminal at rear of the PFU.
- Cable connection at PFU terminals is secure.
- Circuit breaker for the power feed from the local PDP is ON.
- Cable connection at the PDP terminal is secure.

## Checking Status LEDs on MIOs

The table below identifies the operational and transitional states for LED indicators on an MIO /UMIO card.

**Table 16: MIO/UMIO/ Operating States and Status LED Indicators**

Label	LED Color	LED State	Notes
Card Transition			

Label	LED Color	LED State	Notes
Run/Fail	Green	Blink	Card is booting, starting or initializing.
Active	—	OFF	
Redundant	—	OFF	
Master	—	OFF	
Busy	—	OFF	
<b>Card Active – Master (Normal)</b>			
Run/Fail	Green	ON	Card is backed up by other MIO/UMIO.
Active	Green	ON	All ports are backed up by other MIO/UMIO.
Redundant	Green	ON	
Master	Green	ON	
Busy	—	OFF	
<b>Card Active – Master</b>			
Run/Fail	Green	ON	Card is <u>not</u> backed up by other MIO/UMIO.
Active	Green	ON	Port may <u>not</u> be backed up by other MIO/UMIO.
Redundant	Amber	ON	
Master	Green	ON	
Busy	—	OFF	
<b>Card Active – Standby (Normal)</b>			
Run/Fail	Green	ON	Card is online and functioning as a Slave.
Active	—	OFF	Any port can be active.
Redundant	Green	ON	All ports are backed up by other MIO/UMIO.
Master	—	OFF	
Busy	—	OFF	
<b>Card Active – Secondary (Normal)</b>			
Run/Fail	Green	ON	Card is online and functioning as a Slave.
Active	Green	ON	Any port can be active.
Redundant	Green	ON	All ports are backed up by other MIO/UMIO.
Master	—	OFF	
Busy	—	OFF	
<b>Card Active – Secondary</b>			

Label	LED Color	LED State	Notes
Run/Fail	Green	ON	Card is online and functioning as a Slave. Any port can be active. Any port may not be backed up by other MIO/UMIO.
Active	Green	ON	
Redundant	Amber	ON	
Master	—	OFF	
Busy	—	OFF	
<b>Card Switchover</b>			
Run/Fail	Green	ON	Card is online; switchover to or from other MIO/UMIO is in progress.
Active	Green	Blink	
Redundant	Amber	Blink	
Master	Green	Blink	
Busy	—	OFF	
<b>Card Failed</b>			
Run/Fail	Red	ON	Card has failed and is offline.
Active	—	OFF	
Redundant	—	OFF	
Master	—	OFF	
Busy	—	OFF	
<b>Card Offline</b>			
Run/Fail	—	OFF	Card is offline.
Active	—	OFF	
Redundant	—	OFF	
Master	—	OFF	
Busy	—	OFF	
<b>Port Status</b>			
Port – Link	Green	ON	Port is in active mode.
	Amber	ON	Port is in standby mode.
	—	OFF	Port is down.
Port Activity	Green	Blink	Data is being sent/received.
	—	OFF	Data is <u>not</u> being sent/received.

## Checking Status LEDs on Data Processing Cards

The table below identifies the operational and transitional states for LED indicators on a DPC/UDPC or DPC2/UDPC2.

**Table 17: DPC/UDPC or DPC2/UDPC2 Operating States and Status LED Indicators**

Label	LED Color	LED State	Notes
<b>Card Transition</b>			
Run/Fail	Green	Blink	Card is booting, starting or initializing.
Active	—	OFF	
Redundant	—	OFF	
<b>Card Active (Normal)</b>			
Run/Fail	Green	ON	Card is backed up by other DPC/UDPC or DPC2/UDPC2.
Active	Green	ON	
Redundant	Green	ON	
<b>Card Active</b>			
Run/Fail	Green	ON	Card is <b>not</b> backed up by other DPC/UDPC or DPC2/UDPC2.
Active	Green	ON	
Redundant	Amber	ON	
<b>Card Standby (Normal)</b>			
Run/Fail	Green	ON	Card is online and in standby mode.
Active	—	OFF	
Redundant	Green	ON	
<b>Card Migrate</b>			
Run/Fail	Green	ON	Card is online and migrating from or to other DPC/UDPC or DPC2/UDPC2.
Active	Green	Blink	
Redundant	Amber	ON	
<b>Card Failed</b>			
Run/Fail	Red	ON	Card has failed and is offline.
Active	—	OFF	
Redundant	—	OFF	
<b>Card Offline</b>			

Label	LED Color	LED State	Notes
Run/Fail	—	OFF	Card is offline.
Active	—	OFF	
Redundant	—	OFF	

## Checking Status LEDs on FSCs

The table below identifies the operational and transitional states for LED indicators on an FSC.

**Table 18: FSC Operating States and Status LED Indicators**

Label	LED Color	LED State	Notes
<b>Card Transition</b>			
Run/Fail	Green	Blink	Card is booting, starting or initializing.
Active	—	OFF	
Redundant	—	OFF	
Drive 1 Active	—	OFF	SSD 1 is idle.
Drive 2 Active	—	OFF	SSD 2 is idle.
<b>Card Active (Normal)</b>			
Run/Fail	Green	ON	Redundant switch fabric Redundant storage
Active	Green	ON	
Redundant	Green	ON	
Drive 1 Active	Green	Blink	SSD 1 is being accessed.
Drive 2 Active	Green	Blink	SSD 2 is being accessed.
<b>Card Active</b>			
Run/Fail	Green	ON	Non-redundant switch fabric Non-redundant storage
Active	Green	ON	
Redundant	Amber	ON	
Drive 1 Active	Green	Blink	SSD 1 is being accessed.
Drive 2 Active	Green	Blink	SSD 2 is being accessed.
<b>Card Failed</b>			

Label	LED Color	LED State	Notes
Run/Fail	Red	ON	Card has failed and is offline.
Active	—	OFF	
Redundant	—	OFF	
Drive 1 Active	—	OFF	SSD 1 is idle.
Drive 2 Active	—	OFF	SSD 2 is idle.
<b>Card Offline</b>			
Run/Fail	—	OFF	Card is offline.
Active	—	OFF	
Redundant	—	OFF	
Drive 1 Active	—	OFF	SSD 1 is idle.
Drive 2 Active	—	OFF	SSD 2 is idle.

## Checking Status LEDs on SSC

The table below identifies the operational and transitional states for LED indicators on an SSC.

**Table 19: SSC Operating States and Status LED Indicators**

Label	LED Color	LED State	Notes
<b>Card Transition</b>			
Run/Fail	Green	Blink	Card is booting, starting or initializing.
Active	—	OFF	
Redundant	—	OFF	
<b>Card Active (Normal)</b>			
Run/Fail	Green	ON	Card is backed up by other SSC.
Active	Green	ON	
Redundant	Green	ON	
<b>Card Active</b>			
Run/Fail	Green	ON	Card is <u>not</u> backed up by other SSC.
Active	Green	ON	
Redundant	Amber	ON	
<b>Card Failed</b>			

Label	LED Color	LED State	Notes
Run/Fail	Red	ON	Card has failed and is offline.
Active	—	OFF	
Redundant	—	OFF	
<b>Card Offline</b>			
Run/Fail	—	OFF	Card is offline.
Active	—	OFF	
Redundant	—	OFF	
<b>System Indicators</b>			
<b>Normal</b>			
System Status	Green	ON	System is in service.
System Service	—	OFF	There are no failed components.
<b>Failed Components</b>			
System Status	Green	ON	System is in service.
System Service	Amber	ON	There are failed components.
<b>Service Loss and Failed Components</b>			
System Status	Red	ON	System is out of service.
System Service	Amber	ON	There are failed components.
<b>Service Loss with No Failed Components</b>			
System Status	Red	ON	System is out of service.
System Service	—	OFF	There are no failed components.
<b>Offline or Transitioning</b>			
System Status	—	OFF	SSC is offline.
System Service	—	OFF	

## show leds Command

The **show leds** command displays the current operating state (color) of the status LEDs of all cards in the system.







# Initial System Configuration

---

This chapter describes how to configure initial system parameters for the ASR 5500.

It includes the following sections:

- [Basic Configuration, page 97](#)
- [Context-level Security Administrator and Hostname, page 98](#)
- [MIO/UMIO Port Numbering, page 99](#)
- [Configure the Ethernet Management Interface, page 100](#)
- [Configure the System for Remote Access, page 104](#)
- [Configuring SSH Options, page 106](#)
- [Set System Timing, page 109](#)
- [Enable CLI Timestamping, page 112](#)
- [Save the Basic Configuration, page 112](#)
- [Additional Configuration Tasks, page 112](#)

## Basic Configuration

After power is applied to the chassis and the ASR 5500 has successfully booted, the command line interface (CLI) appears on a terminal connected to the Console port of the Master MIO.

The initial configuration requires completing the following tasks via the CLI:

- Configuring a context-level security administrator and hostname.
- Configuring the Ethernet interface(s) on the MIO/UMIO.
- Configuring the system for remote CLI access via Telnet, SSH, or FTP (secured or unsecured).

**Important**

In release 20.0 and higher Trusted StarOS builds, telnet and FTP are disabled. For additional information, see the *System Administration Guide*.

## Context-level Security Administrator and Hostname

**Important**

You must configure a context-level security administrator during the initial configuration. After completing the initial configuration process and ending the CLI session, if you have not configured a security administrator CLI access will be locked.

**Step 1**

At the CLI prompt, enter **config**.

```
[local]asr5500# config
[local]asr5500 (config) #
```

**Step 2**

Enter the context configuration mode by entering **context local**.

The local context is the system's management context. Contexts allow you to logically group services or interfaces. A single context can consist of multiple services and can be bound to multiple interfaces. Enter **context local** at the CLI prompt.

```
[local]asr5500 (config) context local
[local]asr5500 (config-ctx) #
```

**Step 3**

Enter the following command to configure a context-level security administrator for the system:

```
administrator name { password password
| encrypted password enc_password } [ ftp ] [
  no-cli ]
[ timeout-absolute absolute_time ] [
  timeout-idle idle_time ]
```

Keyword/Variable	Description
<i>name</i>	Specifies the security administrator's name as an alphanumeric string of 1 through 32 characters that is case sensitive.
<b>password</b> <i>password</i>	Specifies the password for the security administrator as an alphanumeric string of 1 through 63 characters that is case sensitive.
<b>encrypted password</b>	Specifies the encrypted password for the security administrator. This keyword is only used by the system when you save configuration scripts. The system displays the encrypted keyword in the configuration file as a flag indicating that the variable following the keyword is the encrypted version of the plain text password. Only the encrypted password is saved as part of the configuration file.
<b>ftp</b>	Specifies that the security administrator is allowed to access the system with the File Transfer Protocol (FTP). This option is useful to upload files (configuration or software images).  <b>Note:</b> In release 20.0 and higher <u>Trusted</u> StarOS builds, FTP is disabled.

Keyword/Variable	Description
<b>no-cli</b>	Specifies that the security administrator cannot access the system's command line interface (CLI).  <b>Note:</b> Use this keyword in conjunction with the <b>ftp</b> keyword to allow access to the system with FTP only.
<b>timeout-absolute</b> <i>absolute_time</i>	Specifies the maximum amount of time that the operator can maintain a session with the system.  <i>absolute_time</i> is measured in seconds. Use any integer from 0 through 300000000. The default is 0. When the absolute timeout value is reached, the operator session is automatically terminated.
<b>timeout-idle</b> <i>idle_time</i>	Specifies the maximum amount of time that an operator session can remain idle before being automatically terminated. The <i>idle_time</i> is measured in seconds. Use any integer from 0 through 300000000. The default is 0.

For example:

```
[local]asr5500(config-ctx)# administrator Secure1 301delta timeout-idle 120
```

**Important** For additional information on configuring system administrators, refer to the *System Administration Guide*.

**Step 4** Enter **exit** at the prompt to exit the context configuration mode.

```
[local]asr5500(config-ctx)# exit
[local]asr5500(config)#
```

**Step 5** *Optional:* Enter **system hostname** *hostname* to configure a hostname by which the system will be recognized on the network. *host\_name* is the name by which the system will be recognized on the network. The *hostname* can be up to 63 alphanumeric characters and is case sensitive.

**Important** The new *hostname* replaces the default hostname "asr5500" that appears in the CLI prompt. It also becomes the system hostname parameter for SNMP.

For example:

```
[local]asr5500(config)# system hostname node1033
[local]node1033(config)#
```

## MIO/UMIO Port Numbering

The two 1 GbE ports on the MIO/UMIO cards in slots 5 and 6 can only be used as management ports. 10 GbE ports can only be used for non-local contexts (service ports). MIO/UMIO port numbers are non-contiguous.



### Important

For lab environments where network booting of the chassis is desirable, Ethernet 1 port on an MIO/UMIO can be used to network boot the chassis. Other MIO/UMIO ports cannot be used for network booting.

The MIO/UMIO is equipped with two daughter cards (DCs). Each DC supports ten 10 GbE ports.

Ports are specified in CLI commands by "x/yy" where x is the slot number (5 or 6) and yy the port number (1 to 29). For example, **show port info 5/20** [slot 5, port 20].

**Table 20: MIO/UMIO Port Numbering 0**

Port Number	Type	Connector	MIO DC	Notes
1	1000Base-T	RJ45	—	Management Port
2	1000Base-T	RJ45	—	Management Port
3	RS-232	RJ45	—	Console (serial)
4 – 9	—	—	—	Unassigned
10 – 19	10GbE	SFP+	Top	Service Port
20 – 29	10GbE	SFP+	Bottom	Service Port

The output of the **show port table** command reflects the port numbering scheme in the table above for MIO/UMIO cards equipped with two 10-port, 10 GbE daughter cards.

## Configure the Ethernet Management Interface

### IP Address Notation

When configuring a port interface via the CLI you must enter an IP address. The CLI always accepts an IPv4 address, and in some cases accepts an IPv6 address as an alternative.

For some configuration commands, the CLI also accepts CIDR notation.



#### Important

Always view the online Help for the CLI command to verify acceptable forms of IP address notation.

### IPv4 Dotted-Decimal Notation

An Internet Protocol Version 4 (IPv4) address consists of 32 bits divided into four octets. These four octets are written in decimal numbers, ranging from 0 to 255, and are concatenated as a character string with full stop delimiters (dots) between each number.

For example, the address of the loopback interface, usually assigned the host name localhost, is 127.0.0.1. It consists of the four binary octets 01111111, 00000000, 00000000, and 00000001, forming the full 32-bit address.

IPv4 allows 32 bits for an Internet Protocol address and can, therefore, support  $2^{32}$  (4,294,967,296) addresses.

## IPv6 Colon-Separated-Hexadecimal Notation

An Internet Protocol Version 6 (IPv6) address has two logical parts: a 64-bit network prefix and a 64-bit host address part. An IPv6 address is represented by eight groups of 16-bit hexadecimal values separated by colons (:).

A typical example of a full IPv6 address is 2001:0db8:85a3:0000:0000:8a2e:0370:7334.

The hexadecimal digits are case-insensitive.

The 128-bit IPv6 address can be abbreviated with the following rules:

- Leading zeroes within a 16-bit value may be omitted. For example, the address fe80:0000:0000:0000:0202:b3ff:fe1e:8329 may be written as fe80:0:0:0:202:b3ff:fe1e:8329
- One group of consecutive zeroes within an address may be replaced by a double colon. For example, fe80:0:0:0:202:b3ff:fe1e:8329 becomes fe80::202:b3ff:fe1e:8329.

IPv6 allows 128 bits for an Internet Protocol address and can support  $2^{128}$  (340,282,366,920,938,000,000,000,000,000,000,000) internet addresses.

## CIDR Notation

Classless Inter-Domain Routing (CIDR) notation is a compact specification of an Internet Protocol address and its associated routing prefix. It is used for both IPv4 and IPv6 addressing in networking architectures.

CIDR is a bitwise, prefix-based standard for the interpretation of IP addresses. It facilitates routing by allowing blocks of addresses to be grouped into single routing table entries. These groups (CIDR blocks) share an initial sequence of bits in the binary representation of their IP addresses.

CIDR notation is constructed from the IP address and the prefix size, the latter being the number of leading 1 bits of the routing prefix. The IP address is expressed according to the standards of IPv4 or IPv6. It is followed by a separator character, the slash (/) character, and the prefix size expressed as a decimal number.

The address may denote a single, distinct, interface address or the beginning address of an entire network. In the latter case the CIDR notation specifies the address block allocation of the network. The maximum size of the network is given by the number of addresses that are possible with the remaining, least-significant bits below the prefix. This is often called the host identifier.

For example:

- the address specification 192.168.100.1/24 represents the given IPv4 address and its associated routing prefix 192.168.100.0, or equivalently, its subnet mask 255.255.255.0.
- the IPv4 block 192.168.0.0/22 represents the 1024 IPv4 addresses from 192.168.0.0 to 192.168.3.255.
- the IPv6 block 2001:DB8::/48 represents the IPv6 addresses from 2001:DB8:0:0:0:0:0:0 to 2001:DB8:0:FFFF:FFFF:FFFF:FFFF:FFFF.
- ::1/128 represents the IPv6 loopback address. Its prefix size is 128, the size of the address itself, indicating that this facility consists of only this one address. An application sending a packet to this address will get the packet back after it is looped back by the IPv6 stack. The equivalent IPv4 local host address is 127.0.0.1.

The number of addresses of a subnet defined by the mask or prefix can be calculated as  $2^{\text{address size} - \text{mask}}$ , in which the address size for IPv4 is 32 and for IPv6 is 128. For example, in IPv4, a mask of /29 gives:  $2^{32-29} = 2^3 = 8$  addresses.

## Configuring the Ethernet Management Interface

The procedure below describes how to configure an Ethernet management interface on the primary MIO/UMIO in slot 5.



### Important

Repeat the procedure below to configure the second Ethernet management interface on the MIO/UMIO in slot 5.

**Step 1** Enter **config** to enter the configuration mode.

```
[local]host_name# config
```

**Step 2** Enter **context local** to enter the context configuration mode. The following prompt appears:

```
[local]host_name(config)# context local
[local]host_name(config-ctx)#
```

**Step 3** Enter **interface interface\_name** to specify a name for the interface. *interface\_name* is the name of the interface. The interface name can be between 1 and 79 alphanumeric characters and is case sensitive. The following prompt appears as the system enters the Ethernet Interface Configuration mode:

```
[local]host_name(config-ctx)# interface local01
[local]host_name(config-if-eth)#
```

**Step 4** Configure the IP address for the interface.

- **For IPv4:** Configure an IP address for the interface configured in the previous step by entering **ip address ipaddress subnetmask**. *ip\_address* specifies the IP address for the interface in dotted-decimal format. *subnetmask* specifies the subnet mask for the interface in dotted-decimal or CIDR format.
- **For IPv6:** Configure an IP address for the interface configured in the previous step by entering **ipv6 address ipv6address subnetmask**. *ipv6address* specifies the IP address for the interface in colon-separated-hexadecimal format. *subnetmask* specifies the subnet mask for the interface in colon-separated-hexadecimal or CIDR format.

For example:

```
[local]host_name(config-if-eth)# ip address 10.0.153.100 255.255.255.248
[local]host_name(config-if-eth)# ipv6 address 2620:0:60:48::10/64
```

**Step 5** Enter **exit** to exit the Ethernet interface configuration mode. The following prompt appears:

```
[local]host_name(config-ctx)#
```

**Step 6** If necessary, configure a static route to point the system to a default gateway by entering the following command: **{ ip | ipv6 } route gw\_address interface\_name**. *gw\_address* specifies the IP address of the default gateway in IPv4 dotted-decimal format or IPv6 colon-separated-hexadecimal format). *interface\_name* specifies the name of the interface that was configured in Step 2. Refer to the *System Administration Guide* for additional information.

**Step 7** Enter **exit** at the prompt to exit the context configuration mode. The following prompt appears:

```
[local]host_name(config-ctx)# exit
[local]host_name(config)#
```

**Step 8** Enter **port ethernet slot/port** to enter the Ethernet Port Configuration mode. *slot* is the actual chassis slot in which the MIO/UMIO card is installed. This could be either slot number 5 or 6. *port* is the physical port on the IO/UMIO that will be used. This will be either port 1 or 2. Port 1 is the top most port.

```
[local]host_name(config)# port ethernet slot/port
[local]host_name(config-port-slot/port) #
```

**Step 9** Bind the port to the interface that you created in Step 2. Binding associates the port and all of its settings to the interface. Enter the following commands:

```
[local]host_name(config-port-slot/port) # bind interface interface_name local
[local]host_name(config-port-slot/port) # no shutdown
```

*interface\_name* is the name of the interface that you configured in Step 3.

**Step 10** *Optional* – Configure the port speed by entering the following command:  
**medium { auto | speed { 10 | 100 | 1000 } duplex {full | half} }**

Keyword/Variable	Description
<b>auto</b>	<b>NOTE: Currently MIO/UMIO ports 1 and 2 support link speeds of 1000, 100, or 10 Mbps. The ports will auto-negotiate its speed based on the fastest link partner capability.</b>
<b>speed</b>	<b>NOTE: Currently for MIO/UMIO ports 1 and 2 the speed setting is ignored since the port always operates in auto mode.</b> The possible rates are: <ul style="list-style-type: none"> <li>• <b>10</b> = 10 Mbps</li> <li>• <b>100</b> = 100 Mbps</li> <li>• <b>1000</b> = 1000 Mbps</li> </ul>
<b>duplex</b>	You can implement either a full or half duplex mode. <b>NOTE: Ethernet networking rules dictate that if a device whose interface is configured to auto-negotiate is communicating with a device that is manually configured to support full duplex mode, the first device negotiates with the manually configured speed of the second device, but only communicates in half duplex mode.</b>

**Step 11** Enter **exit** to exit the Ethernet Interface Configuration mode.

```
[local]host_name(config-port-slot/port) # exit
[local]host_name(config) #
```

## Configuring the Management Interface with a Second IP Address

If necessary, you can configure a second IP address on the same MIO management interface.

**Step 1** Enter **configure** to enter the configuration mode. The following prompt appears:

```
[local]host_name# config
[local]host_name(config)#
```

**Step 2** Enter **context local** to enter the context configuration mode. The following prompt appears:

```
[local]host_name(config)# context local
[local]host_name(config-ctx)#
```

**Step 3** Enter **interface interface\_name** to specify the previously named interface.

```
[local]host_name(config-ctx)# interface local01
[local]host_name(config-if-eth)#
```

**Step 4** Configure the second IP address for the interface.

- **For IPv4:** Configure an IP address for the interface configured in the previous step by entering **ip address ipaddress subnetmask**. *ip\_address* specifies the IP address for the interface in dotted-decimal format. *subnetmask* specifies the subnet mask for the interface in dotted-decimal or CIDR format.
- **For IPv6:** Configure an IP address for the interface configured in the previous step by entering **ipv6 address ipv6address subnetmask**. *ipv6address* specifies the IP address for the interface in colon-separated-hexadecimal format. *subnetmask* specifies the subnet mask for the interface in colon-separated-hexadecimal or CIDR format.

For example:

```
[local]host_name(config-if-eth)# ip address 10.0.153.100 255.255.255.248
[local]host_name(config-if-eth)# ipv6 address 2620:0:60:48::10/64
```

**Step 5** Leave the configuration mode by entering **end**:

```
[local]host_name(config-if-eth)# end
[local]host_name#
```

**Step 6** Confirm the interface ip addresses by entering **show config context local**.

## Configure the System for Remote Access

When the system is configured for remote access, an administrative user may access the system from a remote location over a local area network (LAN) or wide area network (WAN) via the following communication protocols:

- Telnet
- Secure Shell (SSH)
- File Transfer Protocol (FTP) (secured or unsecured)
- Trivial File Transfer Protocol (TFTP)





**Important** For maximum security, use SSH v2.



**Important** In release 20.0 and higher Trusted StarOS builds, telnet and FTP are disabled. For additional information, see the *System Administration Guide*.

**Step 1** At the Exec mode CLI command prompt, enter **config** followed by **context local** to enter the Context Configuration mode.

```
[local]host_name# config
[local]host_name(config)# context local
[local]host_name(config-ctx)#
```

**Step 2** Go to a previously defined interface.

```
[local]host_name(config-ctx)# interface interface_name
```

**Step 3** Enter **server telnetd** to allow Telnet access.

```
[local]host_name(config-ctx)# server telnetd
```

**Important** For maximum system security, you should not enable telnet. In release 20.0 and higher Trusted StarOS builds, telnet is disabled.

**Step 4** Enter the following command sequence to allow SSH and SFTP access:

**Important** **v2-rsa** is the default SSH key type.

In StarOS 19.2 and higher, the **v1-rsa** keyword has been removed from and the **v2-dsa** keyword has been concealed within the Context Configuration mode **ssh generate** CLI command. A keyword that was supported in a previous release may be concealed in subsequent releases. StarOS continues to parse concealed keywords in existing scripts and configuration files created in a previous release. But the concealed keyword no longer appears in the command syntax for use in new scripts or configuration files. Entering a question mark (?) will not display a concealed keyword as part of the Help text. A removed keyword generates an error message when parsed.

```
[local]host_name(config-ctx)# ssh generate key type v2-rsa
```

**Step 5** Configure the system to support SFTP:

```
[local]host_name(config-ctx)# server sshd
[local]host_name(config-sshd)# subsystem sftp
[local]host_name(config-sshd)# exit
```

For additional information about SSH, see [Configuring SSH Options](#), on page 106.

**Step 6** Enter **server ftpd** to allow FTP access.

**Important** For maximum system security, you should not enable FTP. In release 20.0 and higher Trusted StarOS builds, FTP is not supported

```
[local]host_name(config-ctx)# server ftpd
```

**Step 7** Enter **server tftpd** to allow TFTP access.

```
[local]host_name(config-ctx)# server tftpd
```

**Step 8** Enter **exit** to exit the context configuration mode.

```
[local]host_name(config-ctx)# exit
[local]host_name(config)#
```

- Step 9** Enter **end** to exit the configuration mode.
- ```
[local]host_name(config)# end
[local]host_name#
```
- Step 10** Proceed to [Save the Basic Configuration](#), on page 112.

## Configuring SSH Options

SSHv2 RSA is the only version of SSH supported under StarOS. Keywords previously supported for SSHv1 RSA and SSHv2 DSA have been removed from or concealed within the StarOS CLI.



**Important** A keyword that was supported in a previous release may be concealed in subsequent releases. StarOS continues to parse concealed keywords in existing scripts and configuration files created in a previous release. But the concealed keyword no longer appears in the command syntax for use in new scripts or configuration files. Entering a question mark (?) will not display a concealed keyword as part of the Help text. Removed keywords generate an error message when parsed.

Version 1 of the SSH protocol is now obsolete due to security vulnerabilities. The **v1-rsa** keyword has been removed for the Context Configuration mode **ssh** command. Running a script or configuration that uses the SSHv1-RSA key returns an error message and generates an event log. The output of the error message is shown below:

```
CLI print failure Failure: SSH V1 contains multiple structural vulnerabilities and is no longer considered secure. Therefore we don't support v1-rsa SSH key any longer, please generate a new v2-rsa key to replace this old one.
```

If the system boots from a configuration that contains the **v1-rsa** key, you can expect a boot failure when logging in through SSH. The workaround is to log in via the Console port, re-generate a new ssh v2-rsa key, and configure server sshd. It will then be possible to log in via ssh.

The **v2-dsa** keyword is now concealed for the Context Configuration mode **ssh** command

The **v1-rsa** keyword has been removed from the Exec mode **show ssh key** CLI command.

## Setting SSH Key Size

The Global Configuration mode **ssh key-size** CLI command configures the key size for SSH key generation for all contexts (RSA host key only).

- Step 1** Enter the Global Configuration mode.
- ```
[local]host_name# configure
[local]host_name(config)#
```
- Step 2** Specify the bit size for SSH keys.
- ```
[local]host_name(config)# ssh key-size { 2048 | 3072 | 4096 | 5120 | 6144 | 7168 | 9216 }
```
- The default bit size for SSH keys is 2048 bits.

---

## Generating SSH Keys

The **ssh generate** command generates a public/private key pair which is to be used by the SSH server. The **v1-rsa** keyword has been removed from and the **v2-dsa** keyword concealed within the **ssh generate** CLI command. The only keyword available for generating SSH keys is **v2-rsa**.



---

**Important** The generated key pair remains in use until the command is issued again.

---

---

**Step 1** Enter the context configuration mode:  
[local]host\_name(config)# **context context\_name**  
[local]host\_name(config-ctx)#

**Step 2** Generate an SSH key pair.  
[local]host\_name(config-ctx)# **ssh generate key type v2-rsa**  
[local]host\_name(config-ctx)#

---

## Setting SSH Key Pair

The **ssh key** command sets the public/private key pair to be used by the system. The **v2-dsa** keyword is concealed in the **ssh key** command.

---

Specify the SSH key pair parameters.

```
[local]host_name(config-ctx)# ssh key data length octets type v2-rsa
```

Notes:

- **data** is the encrypted key expressed as an alphanumeric string of 1 through 1023 characters
- **length octets** is the length of the encrypted key in octets expressed as an integer from 0 through 65535
- **type** specifies the key type; **v2-rsa** is the only supported type.

**Important** *For releases prior to 20.0, StarOS supports a maximum of 64 configurable authorized SSH keys. For release 20.0 and higher, StarOS supports a maximum of 200 configurable authorized SSH keys.*

---

## Specifying SSH Encryption Ciphers

The SSH Configuration mode **ciphers** CLI command configures the cipher priority list in `sshd` for SSH symmetric encryption. It changes the cipher options for that context.

**Step 1** Enter the SSH Configuration mode.  
`[local]host_name(config-ctx) # server sshd`

**Step 2** Specify the desired encryption algorithms.  
`[local]host_name(config-sshd) # ciphers algorithm`

Notes:

- *algorithm* is a string of 1 through 511 alphanumeric characters that specifies the algorithm(s) to be used as a single string of comma-separated variables (no spaces) in priority order from those shown below:
  - **blowfish-cbc** – symmetric-key block cipher, Cipher Block Chaining, (CBC)
  - **3des-cbc** – Triple Data Encryption Standard, CBC
  - **aes128-cbc** – Advanced Encryption Standard (AES), 128-bit key size, CBC
  - **aes128-ctr** – AES, 128-bit key size, Counter-mode encryption (CTR)
  - **aes192-ctr** – AES, 192-bit key size, CTR
  - **aes256-ctr** – AES, 256-bit key size, CTR
  - **aes128-gcm@openssh.com** – AES, 128-bit key size, Galois Counter Mode [GCM], OpenSSH
  - **aes256-gcm@openssh.com** – AES, 256-bit key size, GCM, OpenSSH
  - **chacha20-poly1305@openssh.com** – ChaCha20 symmetric cipher, Poly1305 cryptographic Message Authentication Code [MAC], OpenSSH

The default string for algorithm is:

```
blowfish-cbc,3des-cbc,aes128-cbc,aes128-ctr,aes192-ctr,aes256-ctr,aes128-gcm@openssh.com,
aes256-gcm@openssh.com,chacha20-poly1305@openssh.com
```

**Step 3** Exit the SSH Configuration mode.  
`[local]host_name(config-sshd) # end`  
`[local]host_name#`

# Set System Timing

## Setting the System Clock and Time Zone

Use the following command sequence to configure the system clock and time zone:

```
[local]host_name# clock set YYYY:MM:DD:HH:mm or YYYY:MM:DD:HH:mm:ss
[local]host_name# config
[local]host_name(config)# clock timezone timezone [ local ]
[local]host_name(config)# end
[local]host_name#
```



### Important

See the online help for the **clock timezone** command for a complete list of supported time zones. The optional **local** keyword indicates that the time zone specified is the local timezone.



### Important

Daylight Savings Time is automatically adjusted for time zones supporting it.

Save your configuration as described in [Save the Basic Configuration, on page 112](#).

Enter **show clock** to verify that you configured the time and time zone correctly:

```
[local]host_name# show clock
Wednesday October 10 13:08:27 us-eastern 2012
```

## Configuring Network Time Protocol Support

This section describes how to enable the use of the Network Time Protocol (NTP) on the ASR 5500 chassis.

### Overview of NTP Support

Many of the services offered by the ASR 5500 platform require accurate timekeeping derived through NTP. If the time reference(s) used by StarOS are not accurate, the services may be unreliable. For this reason it should be assumed that normal system operation requires that NTP be configured.

The system uses NTP to synchronize internal clocks on the chassis to external time sources (typically GPS NTP sources, or other Stratum 2 or 3 servers, switches or routers).

By default, NTP is not enabled externally and should be configured when the system is initially installed. When enabled, the active MIO/UMIO will synchronize with external sources. If not enabled, the active MIO/UMIO will use its local clock as a time source. In the event of an NTP server or network outage, an already running MIO/UMIO will continue to use NTP to maintain time accuracy, but in a holdover mode.

All cards with CPUs synchronize to the active MIO/UMIO internally. This occurs even if an external NTP server is not configured. In the event of a MIO/UMIO switchover, all other cards will start synchronizing with the newly active MIO/UMIO automatically.

The system should have:

- NTP enabled.

- NTP configured for use in the local context only. Use of other contexts (which can be specified in the enable configurable) will cause issues.
- NTP configured for three external NTP servers. With three or more servers, outliers and broken or misconfigured servers can be detected and excluded. Generally, the more servers the better (within reason).

**Important**

Do not configure any external NTP servers using the **prefer** keyword. The NTP clock selection algorithms already have the built-in ability to pick the best server. Use of **prefer** usually results in a poorer choice than NTP can determine for itself.

**Important**

Do not change the **maxpoll**, **minpoll**, or **version** keyword settings unless instructed to do so by Cisco TAC.

## Basic NTP Configuration

**Important**

Configure the system clock and time zone prior to implementing NTP support. This greatly simplifies the time zone shift that must be corrected by the NTP server. See [Setting the System Clock and Time Zone, on page 109](#).

Use the following example to configure the necessary NTP association parameters:

```
[local]host_name# config
[local]host_name(config)# ntp
[local]host_name(config-ntp)# enable
[local]host_name(config-ntp)# server ip_address1
[local]host_name(config-ntp)# server ip_address2
[local]host_name(config-ntp)# server ip_address3
[local]host_name(config-ntp)# end
[local]host_name#
```

By default *context\_name* is set to *local*. This is the recommended configuration.

A number of options exist for the **ntp server** command. Refer to the *NTP Configuration Mode Commands* chapter in the *Command Line Interface Reference* for more information.

**Important**

Configure the system with at least three (preferably four) NTP servers.

Save the configuration as described in [Save the Basic Configuration, on page 112](#).

## Configuring NTP Servers with Local Sources

NTP can use network peers, local external clocks (such as GPS devices), or a local clock with no external source.

A local clock with no external source is usually a last-resort clock when no better clock is available. It is typically configured on a site's intermediate NTP server so that when a WAN network outage occurs, hosts within the site can continue to synchronize amongst themselves.

You can configure this in `ntpd` or on many commercially available NTP devices. This local clock should always have a high stratum number (8+) so that under normal conditions (when real sources are available) this local clock will not be used.

## Using a Load Balancer

The NTP daemon and protocol assume that each configured server is running NTP. If an NTP client is configured to synchronize to a load balancer that relays and distributes packets to a set of real NTP servers, the load balancer may distribute those packets dynamically and confuse the NTP client. NTP packets are sensitive to latency and jitter. Relaying them through a load balancer can confuse the NTP client and is not a supported practice.

## Verifying the NTP Configuration

To verify the NTP Configuration, enter the **show ntp associations** command at the Exec mode. The output displays information about all NTP servers.

The table below lists and briefly describes the parameters that appear in the output of the **show ntp associations** command.

**Table 21: Output Parameters for show ntp associations**

| Column Title | Description                                                                                                                                                                                                                                                                                                                                                          |
|--------------|----------------------------------------------------------------------------------------------------------------------------------------------------------------------------------------------------------------------------------------------------------------------------------------------------------------------------------------------------------------------|
| remote       | Lists the current NTP servers. One of these characters precedes each IP address to show the server's current condition: <ul style="list-style-type: none"> <li>• () Rejected/No response</li> <li>• X False tick</li> <li>• (.) Excess</li> <li>• - Outlyer</li> <li>• + Candidate</li> <li>• # Selected</li> <li>• * System peer</li> <li>• (o) PPS peer</li> </ul> |
| refid        | Last reported NTP reference to which the server is synchronizing.                                                                                                                                                                                                                                                                                                    |
| st           | NTP server stratum level.                                                                                                                                                                                                                                                                                                                                            |
| t            | Communication type: broadcast, multicast, etc.                                                                                                                                                                                                                                                                                                                       |
| when         | Number of seconds since the last contact.                                                                                                                                                                                                                                                                                                                            |
| poll         | Polling interval between the system and the NTP server.                                                                                                                                                                                                                                                                                                              |

| Column Title | Description                                                                                                                              |
|--------------|------------------------------------------------------------------------------------------------------------------------------------------|
| reach        | Octal value of the reachability shift register indicating which responses were received for the previous eight polls to this NTP server. |
| delay        | Round-trip delay (in milliseconds) for messages exchanged between the system and the NTP server.                                         |
| offset       | Number of milliseconds by which the system clock must be adjusted to synchronize it with the NTP server.                                 |
| jitter       | Jitter in milliseconds between the system and the NTP server.                                                                            |

## Enable CLI Timestamping

To display a timestamp (date and time) for every command that is executed on the CLI, enter the **timestamps** command at the root prompt for the Exec mode:

```
[local]host_name# timestamps
```

Immediately after you execute the command, the date and time appear.

Save the configuration as described in [Save the Basic Configuration, on page 112](#).

## Save the Basic Configuration

Save this basic system configuration information to a file locally. The following procedure saves the configuration file to flash memory in the MIO/UMIO.

---

**Step 1** You must be at the root prompt for the Exec mode to save the configuration file.

```
[local]host_name#
```

**Step 2** To save your current configuration, enter the following command:

```
[local]host_name# save configuration /flash/system.cfg
```

This completes the basic configuration process.

---

## Additional Configuration Tasks

Establishing the basic configuration allows an operator to access the ASR 5500 for management purposes. Additional configuration settings are required for full operational deployment within a provider network. To complete these tasks, refer to the following documents:

- *System Administration Guide*
- *Command Line Interface Reference*



- *Administration Guide* specific to the type of product being deployed.
- *StarOS Release Notes*





# System Monitoring

---

This chapter describes how to use the command line interface (CLI) **show** commands to monitor system status and performance. These commands allow an operator to obtain information on all aspects of the system, from current software configuration to call activity and status.

The selection of commands described in this chapter provides useful and in-depth information for monitoring the hardware. For additional information on these and other **show** command keywords, refer to the CLI on-line Help and the *Command Line Interface Reference*.

This chapter includes the following sections:

- [Monitoring, page 115](#)
- [Counters and Bulkstats, page 118](#)
- [Summary of Maintenance Tasks, page 119](#)

## Monitoring

This section contains commands used to monitor system performance and the status of tasks, managers, applications, and various other software components. Most of the procedure commands are useful for both maintenance and diagnostics. There is no limit to the frequency that any of the individual commands or procedures can be implemented.

### Daily - Standard Health Check

The standard health check is divided into independent procedures:

- Hardware Status
- Physical Layer Status
- System Status and Performance

Table 22: Health Checks

| To do this:                                                                                                                                                                                                                                | Enter this command:                                                                         |
|--------------------------------------------------------------------------------------------------------------------------------------------------------------------------------------------------------------------------------------------|---------------------------------------------------------------------------------------------|
| <b>Hardware</b>                                                                                                                                                                                                                            |                                                                                             |
| All hardware problems generate alarms that generate SNMP traps. Review the trap history.                                                                                                                                                   | <b>show snmp trap history</b>                                                               |
| Check the status of the PFUs. The command output indicates the power level for the cards in the chassis. All active cards should be in an "ON" state.                                                                                      | <b>show power chassis</b>                                                                   |
| Check the power status of an individual chassis.                                                                                                                                                                                           | <b>show power all</b>                                                                       |
| View the status of the fan trays.                                                                                                                                                                                                          | <b>show fans</b>                                                                            |
| View the LED status for all installed cards. All LEDs for active cards should be green.                                                                                                                                                    | <b>show leds all</b>                                                                        |
| Checking the temperatures confirms that all cards and fan trays are operating within safe ranges to ensure hardware efficiency.                                                                                                            | <b>show temperature</b>                                                                     |
| <b>Physical Layer</b>                                                                                                                                                                                                                      |                                                                                             |
| View a listing of all installed application cards in a chassis.<br>Determine if all required cards are in active or standby state and not offline.<br>Displays include slot numbers, card type, operational state, and attach information. | <b>show card table</b><br><b>show card info</b><br><b>show card diags</b>                   |
| View the number and status of physical ports on each line card. Output indicates Link and Operation state for all interfaces – Up or Down.                                                                                                 | <b>show port table all</b>                                                                  |
| Verify CPU usage and memory.                                                                                                                                                                                                               | <b>show cpu table</b><br><b>show cpu info</b>                                               |
| <b>System Status and Performance</b>                                                                                                                                                                                                       |                                                                                             |
| Check a summary of CPU state and load, memory and CPU usage.                                                                                                                                                                               | <b>show cpu table</b>                                                                       |
| Check utilization of NPUs within the chassis.                                                                                                                                                                                              | <b>show npu utilization table</b>                                                           |
| Check availability of resources for sessions.                                                                                                                                                                                              | <b>show resources session</b>                                                               |
| Review session statistics, such as connects, rejects, hand-offs, collected in 15-minute intervals.                                                                                                                                         | <b>show session counters historical</b>                                                     |
| View duration, statistics, and state for active call sessions.                                                                                                                                                                             | <b>show session duration</b><br><b>show session progress</b><br><b>show session summary</b> |

| To do this:                                                                                                                                                                                                                                                                                       | Enter this command:                                                                          |
|---------------------------------------------------------------------------------------------------------------------------------------------------------------------------------------------------------------------------------------------------------------------------------------------------|----------------------------------------------------------------------------------------------|
| Display statistics for the Session Manager.                                                                                                                                                                                                                                                       | <b>show session subsystem facility sessmgr all</b>                                           |
| Check the amount of time that the system has been operational since the last downtime (maintenance or other). This confirms that the system has not rebooted recently.                                                                                                                            | <b>show system uptime</b>                                                                    |
| Verify the status of the configured NTP servers. Node time should match the correct peer time with minimum jitter.                                                                                                                                                                                | <b>show ntp status</b>                                                                       |
| Check the current time of a chassis to compare network-wide times for synchronisation or logging purposes. Ensure network accounting and/or event records appear to have consistent timestamps.                                                                                                   | <b>show clock universal</b>                                                                  |
| View both active and inactive system event logs.                                                                                                                                                                                                                                                  | <b>show logs</b>                                                                             |
| Check SNMP trap information. The trap history displays up to 400 time-stamped trap records that are stored in a buffer. Through the output, you can observe any outstanding alarms on the node and contact the relevant team for troubleshooting or proceed with SGSN troubleshooting guidelines. | <b>show snmp trap history</b>                                                                |
| Check the crash log. Use this command to determine if any software tasks have restarted on the system.                                                                                                                                                                                            | <b>show crash list</b>                                                                       |
| Check current alarms to verify system status                                                                                                                                                                                                                                                      | <b>show alarm outstanding all</b><br><b>show alarm all</b>                                   |
| View system alarm statistics to gain an overall picture of the system's alarm history.                                                                                                                                                                                                            | <b>show alarm statistics</b>                                                                 |
| If enabled, view statistics associated with Service Redundancy (SRP) protocol and Inter-Chassis Session Recovery (ICSR).                                                                                                                                                                          | <b>show srp info</b><br><b>show srp monitor all</b><br><b>show srp checkpoint statistics</b> |

## Periodic Status Checks

Depending upon system usage and performance, you may want to perform these tasks more frequently than recommended.

**Table 23: Periodic Status Checks**

| To do this:                                   | Enter this command: |
|-----------------------------------------------|---------------------|
| <b>Monthly</b>                                |                     |
| Check for unused or unneeded files on /flash. | <b>dir /flash</b>   |

| To do this:                                                                                                                                                                                                                                                                                                                                                                          | Enter this command:                                                                                                                                                                                     |
|--------------------------------------------------------------------------------------------------------------------------------------------------------------------------------------------------------------------------------------------------------------------------------------------------------------------------------------------------------------------------------------|---------------------------------------------------------------------------------------------------------------------------------------------------------------------------------------------------------|
| Delete unused or unneeded files to conserve space using the <b>delete</b> command. You should also perform the next action in this list. See Note below.                                                                                                                                                                                                                             | <b>delete /flash/&lt;filename&gt;</b>                                                                                                                                                                   |
| Synchronize the filesystems on both MIO/UMIO/s to ensure consistency between the two.                                                                                                                                                                                                                                                                                                | <b>filesystem synchronize all</b>                                                                                                                                                                       |
| Generate a crash list (and other <b>show</b> command information) and save the output as a tar file.                                                                                                                                                                                                                                                                                 | <b>show support details</b> <to location and filename>                                                                                                                                                  |
|                                                                                                                                                                                                                                                                                                                                                                                      | <b>Flash:</b> [file: ] { /flash   /pcmcia1   /hd } [ /directory ] /file_name                                                                                                                            |
|                                                                                                                                                                                                                                                                                                                                                                                      | <b>TFTP:</b> tftp://{ host [ :port# ] } [ /directory ] /file_name                                                                                                                                       |
|                                                                                                                                                                                                                                                                                                                                                                                      | <b>SFTP:</b> [ ftp:   sftp: ]//[ username [ :password ]@ ] { host } [ :port# ] [ /directory ] /file_name<br><b>NOTE:</b> In release 20.0 and higher <u>Trusted</u> StarOS builds, FTP is not supported. |
| <b>NOTE:</b> If there is an issue with space, you can remove alarm and crash information from the system; however, this practice is not recommended. Support and engineering personnel use these records for troubleshooting if a problem should develop. You should request assigned support personnel to remove these files after storing the information for possible future use. |                                                                                                                                                                                                         |
| <b>Every 6 Months</b>                                                                                                                                                                                                                                                                                                                                                                |                                                                                                                                                                                                         |
| View a listing of all cards installed in the chassis with hardware revision, part, serial, assembly, and fabrication numbers.                                                                                                                                                                                                                                                        | <b>show hardware card</b><br><b>show hardware inventory</b>                                                                                                                                             |
| View all cards installed in the chassis with hardware revision, and the firmware version of the on-board Field Programmable Gate Array (FPGAs).                                                                                                                                                                                                                                      | <b>show hardware version board</b>                                                                                                                                                                      |
| You should replace the particulate air filter installed directly above the lower fan tray in the chassis. Refer to the <i>Replacing the Chassis Air Filter</i> section of this guide for detailed instructions.                                                                                                                                                                      |                                                                                                                                                                                                         |

## Counters and Bulkstats

The ASR 5500 maintains many counters for gathering statistics and troubleshooting. In general you should not regularly clear the counters, just let them increment over time. Counters track events since the chassis booted (unless cleared), unlike **show** commands that give the current state (for example, the current number of calls). See the on-line help for a list of choices. A partial list of counters to choose from are:

- show port datalink counters
- show port npu counters
- show radius counters all

- show l2tp full statistics
- show session disconnect reasons
- show session counters historical all (This is an excellent command to see the call volume history for past three days.)

You may clear the counters via CLI **clear** commands.

A bulk statistics feature allows you to push a very large array of statistical data to a remote server. Bulkstats provide detailed information about the chassis' condition, particularly over extended periods of time.

See the *Configuring Bulk Statistics* section in the *System Administration Guide* for more information.

## Summary of Maintenance Tasks

This section contains a quick reference for when to perform various maintenance operations on the ASR 5000 chassis. These operations include, but are not limited to:

- Load on the chassis
- The number of operators regularly accessing it
- The placement of the chassis within your network
- Available staff to perform maintenance tasks
- Support level agreements within your organization
- The specifics of your chassis configuration
- Your organization's experience with the types of issues, such as subscriber or network, that you encounter over time

### Constant Attention

- Watch SNMP traps for alarms/thresholds and take appropriate action. The traps inform you of serious problems that can occur on the system, including those that do not involve the ASR 5500.
- If you have an Element Management System (EMS) server that relies on bulkstats and other data, pay attention to alarms and call load.

### Daily

- Analyze system logs for any unusual entries.
- Look at call volume and throughput for consistency and expected patterns.

### Weekly

- Check the system clock if NTP is not enabled.

## Monthly

- Clear the /flash filesystem of files that are not needed.

## 6 Months

- Change the air filters.

## No Specific Time Frame

- If you make a config change that you want to be permanent, synchronize filesystems between MIO/UMIOs and save the configuration to /flash.
- For an expired password, re-enable the operator as soon as possible.
- If the boot system priority is approaching a low value, reset it to a higher priority.
- When you finish troubleshooting with runtime logging, remove the logging commands from the config.
- Maintain your SNMP trap server.
- Maintain your syslog server.





## Replaceable Components

---

This chapter describes how to remove and replace the following components:

- [Air Filters, page 121](#)
- [Fan Tray Units, page 127](#)
- [PFU, page 135](#)
- [Circuit Cards, page 137](#)
- [Returning Failed Components, page 147](#)

### Air Filters

Lower fan trays draw ambient air into the chassis. Each is equipped with a particulate air filter to prevent dust and debris from entering the chassis. The two air filters (one front and one rear) must be changed periodically to ensure proper ventilation and air flow through the chassis.

You should replace the air filters at least every six months. Keep replacement air filters on site. A single kit includes filters for both the front fan tray and the rear fan tray (ASR55-FLTR-AIR-F=). Having this kit on-hand ensures that qualified service personnel can quickly replace the filters as necessary. The filters should be replaced during a maintenance window when low traffic volume is expected.

### Determining When an Air Filter Needs Replacing

If the air filters are replaced at least every six months as part of routine maintenance, there should be no need for out-of-cycle replacement. However, under certain conditions, the air filters may need replacement between maintenance periods.

#### High Operating Temperatures and Fan Speeds

One possible indication that air filters need to be replaced is if the chassis temperature remains high for extended periods of time. This condition causes the multi-speed fans to run at high speed. Clogged and dirty air filters could hinder air flow through the chassis and result in higher operating temperatures.

## Temperature and Fan Alarm Commands

### show fans Command

To monitor chassis temperature and fan speed, issue the **show fans** command in the CLI Exec mode.

The following is a sample output for this command:

```
[local]asr5500# show fans
Lower Rear Fan Tray: State=Normal Speed=65% Temp=27 C
Lower Front Fan Tray: State=Normal Speed=65% Temp=27 C
Upper Rear Fan Tray: State=Normal Speed=70% Temp=28 C
Upper Front Fan Tray: State=Normal Speed=70% Temp=40 C
```



#### Important

The safe operating temperature range for the chassis and its components is between -5 degrees C and 50 degrees C (23 degrees F and 122 degrees F).

### show temperature Command

The **show temperature** command displays the relative temperature state of all cards currently installed, as well as the ambient temperature at all fan tray units.

```
[local]asr5500# show temperature
Card 2: Normal
Card 5: Normal
Card 6: Normal
Card 7: Normal
Card 9: Normal
Card 11: Normal
Card 12: Normal
Card 14: Normal
Card 15: Normal
Card 16: Normal
Card 17: Normal
Fan Lower Rear: 26 C
Fan Lower Front: 27 C
Fan Upper Rear: 28 C
Fan Upper Front: 40 C
```

## Replacing an Air Filter



#### Caution

Do not operate the chassis for extended periods of time after removing an air filter. Doing so will cause dust to build up within the chassis, possibly hindering air flow and clogging open connector ports.

The fan tray filters are mounted underneath the front and rear card cages. A gap between the top of the fan tray unit and the air filter allows you to remove the filter without having to remove the fan tray. The air filter is spring-loaded at the rear.



#### Caution

Do not attempt to install air filters in the space above the upper fan trays. The top of the chassis is not designed for air filters. Installing air filters above the upper fan trays may cause power shorts.

## Front Air Filter



**Caution** Installing the air filter incorrectly may cause over-temperature conditions within the system.

- 
- Step 1** Remove the bottom cover panel from the chassis. Firmly grasp the side edges of the panel and pull up and away to unsnap the panel. Put the panel safely aside. See figure below.
- Step 2** Loosen the screws securing the lower fan tray access cover. Remove the cover and set it safely aside.
- Step 3** In the gap above the top of the fan tray, locate the two plastic tabs that hang down from the front of the air filter. Pull the tabs down and back towards the midplane to free the filter from the lip under the front rail of the card cage.
- Step 4** While continuing to hold the tabs, allow the filter to spring forward and downward to clear the retaining lip and the slot at the rear of the card cage. Remove the old filter from the chassis.
- Step 5** Verify that the arrows located on the sides of the replacement air filter point upwards (metal grid facing up). These arrows indicate the direction of the airflow into the chassis through the filter. The spring indicates the rear of the filter and goes toward the midplane.
- Step 6** Slide the replacement air filter into the gap above the fan tray assembly towards the midplane. Tilt the filter slightly upward to catch the slot in back of the card cage.
- Step 7** Push the filter into the rear slot and flush with the bottom of the card cage. Allow the filter to spring forward into the lip under the front rail of the card cage. The plastic tabs should be hanging down.
- Step 8** Reinstall the fan tray access cover.
- Step 9** Reinstall the chassis cover panel by snapping it in place.
- Step 10** Discard the old air filter.

**Figure 25: Front Air Filter Location**

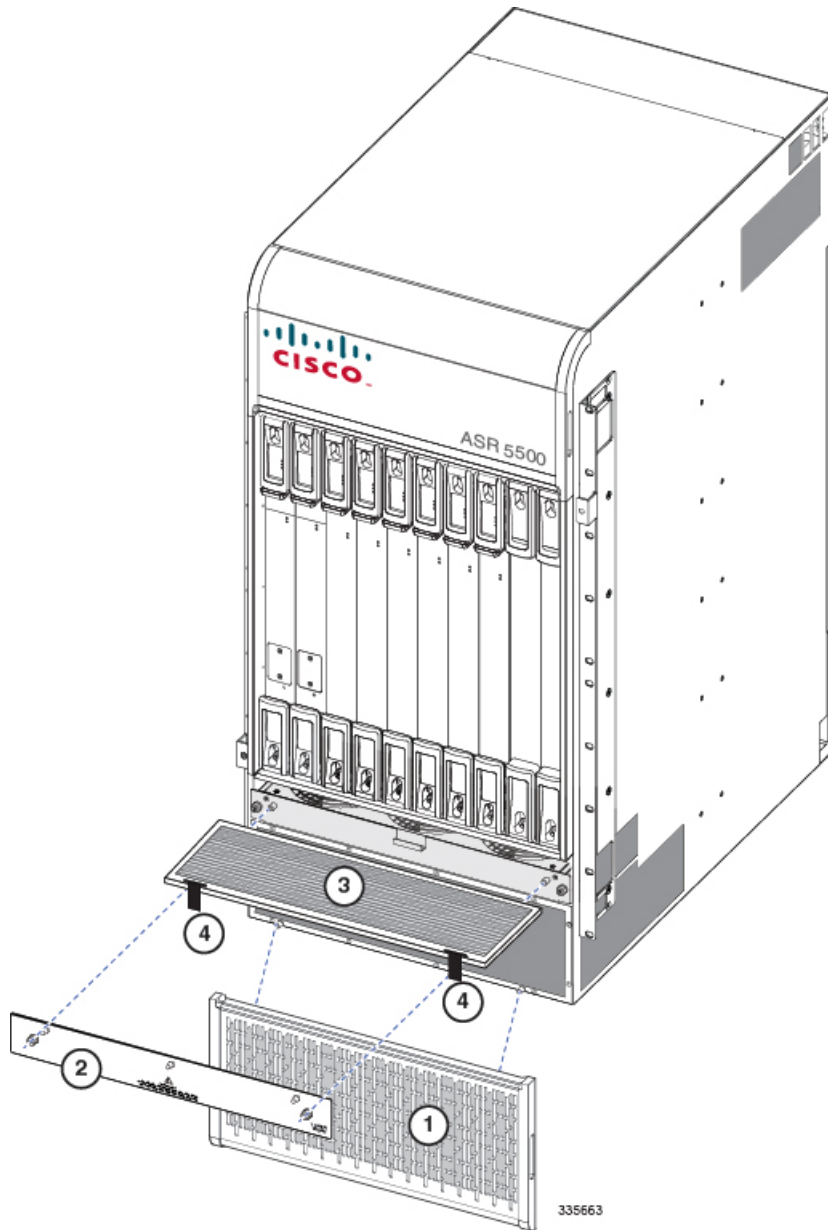

|   |                                      |   |              |
|---|--------------------------------------|---|--------------|
| 1 | Cover panel                          | 2 | Access Cover |
| 3 | Front air filter (ASR55-FLTR-AIR-F=) | 4 | Pull tab     |

## Rear Air Filter



---

**Caution** Installing the air filter incorrectly may cause over-temperature conditions within the system.

---

- 
- Step 1** Remove the bottom cover panel from the chassis. Firmly grasp the side edges of the panel and pull up and away to unsnap the panel. Put the panel safely aside. See figure below.
- Step 2** Loosen the screws securing the lower fan tray access cover. Remove the cover and set it safely aside.
- Step 3** Because of the narrow gap between the fan unit and air filter, use a flat blade screw driver to gently force the air filter back toward the mid plane. Allow the filter to spring downward and forward, away from the retaining lip at the front of the card cage.
- Step 4** Verify that the arrows located on the sides of the replacement air filter point upwards (metal grid facing up). These arrows indicate the direction of the airflow into the chassis through the filter. The spring indicates the rear of the filter and goes toward the midplane.

- Step 5** Slide the replacement air filter into the gap above the fan tray assembly towards the midplane. Tilt the filter slightly upward to catch the slot in back of the card cage.
- Step 6** Use a flat blade screwdriver to push the filter into the rear slot and flush with the bottom of the card cage. Allow the filter to spring forward into the lip under the front rail of the card cage. The plastic tabs should be hanging down.
- Step 7** Reinstall the fan tray access cover.
- Step 8** Reinstall the chassis cover panel by snapping it in place.
- Step 9** Discard the old air filter.

**Figure 26: Rear Air Filter Location**

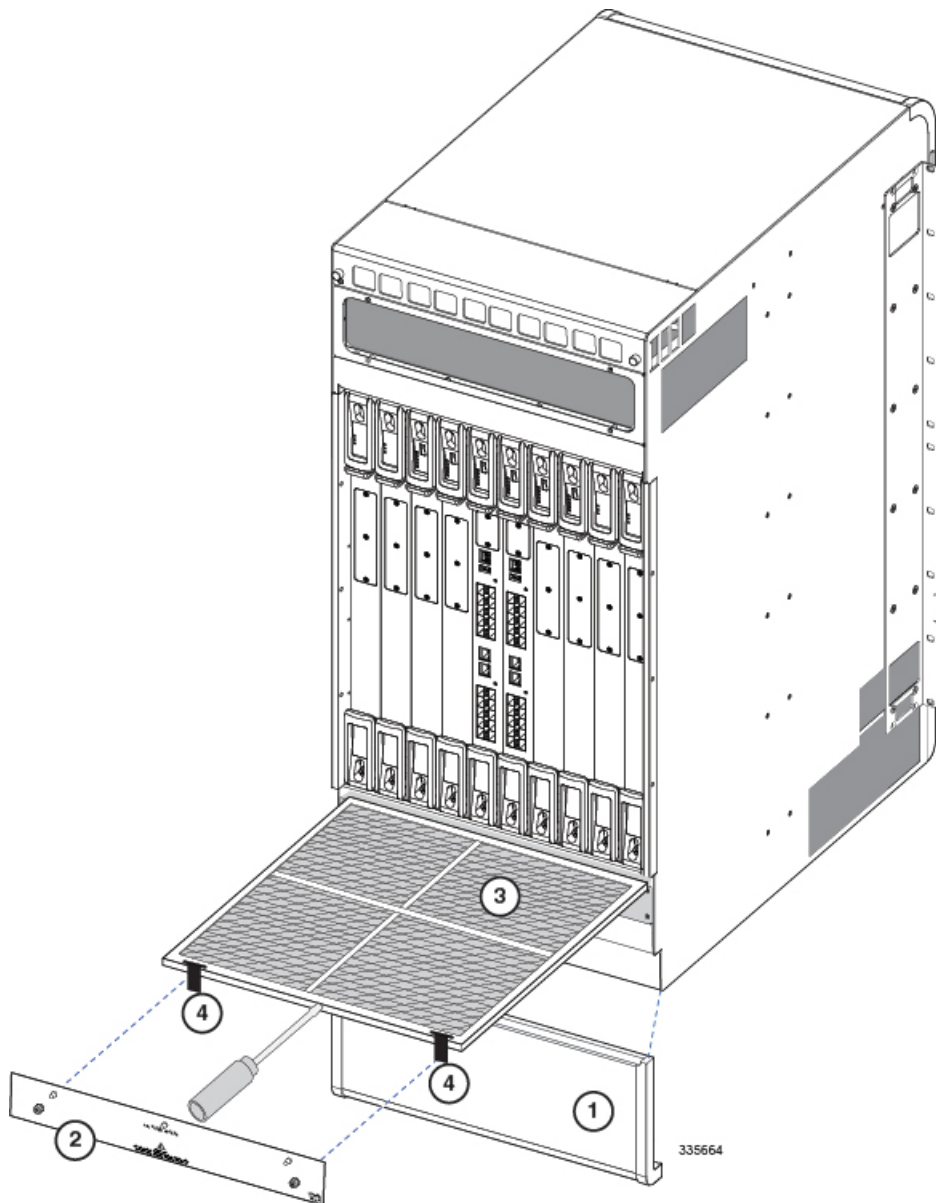

|   |                                     |   |              |
|---|-------------------------------------|---|--------------|
| 1 | Cover panel                         | 2 | Access Cover |
| 3 | Rear air filter (ASR55-FLTR-AIR-R=) | 4 | Pull tab     |

## Fan Tray Units

The four fan tray units draw air up through the chassis for cooling and ventilation. The heated air exhausts through the vents at the rear and sides of the chassis.

This section describes how to remove and replace the front and rear fan tray units should there be a partial or complete failure of a unit.



### Caution

Do not operate the chassis for more than a very brief period of time (less than one minute) with one or more fan trays out of service. Doing so may cause the system to overheat and result in component damage.



### Important

Each front fan tray is controlled by its corresponding rear fan tray. Removal or failure of a rear fan tray will cause the corresponding front fan tray to cease running.

## Determining Whether a Fan Tray Unit Needs Replacing

The system has several ways to indicate a fan tray failure. The first indicator is that the System Status LED on the System Status Card (SSC) illuminates red to indicate the failure of a chassis component.

If you see a red System Status LED on the SSC, you can determine whether it is a fan tray failure by using the CLI. Refer to [Temperature and Fan Alarm Commands, on page 122](#) and [show temperature Command, on page 122](#).

## Replacing Front Fan Trays



### Caution

Fan tray units contain multiple fans that spin at a high rate of speed when the system is powered on. If the system is powered on when a fan tray is removed, do not touch moving fans. To minimize the risk of personal injury and potential equipment damage, pull the fan tray towards you until the fan tray extends out of the chassis approximately two inches (5 cm). Wait a few seconds to allow fans to spin down before fully removing the fan tray.

**Important**

---

Have the replacement fan tray available and ready to be installed before starting the replacement procedure.

---



## Replace the Upper Fan Tray

- 
- Step 1** At the front of the chassis, remove the cover panel from the top of the chassis. Firmly grasp the side edges of the panel and pull up and away to unsnap the panel. Put the panel safely aside. See figure below.
- Step 2** Loosen the screws and remove the upper fan tray access panel from the chassis. Place it safely aside.
- Step 3** Loosen the two screws that secure the fan tray to the chassis.
- Step 4** Grasp the center pull and pull the failed fan tray unit from the chassis.
- Step 5** Set the failed fan tray safely aside.
- Step 6** Hold the front of the replacement fan tray by its sides and align it with the upper fan tray bay of the chassis.
- Step 7** Slowly slide the fan tray into the chassis along the guides until the rear connector is firmly seated in the midplane. If the ASR 5500 is powered up, the fans should begin spinning.
- Step 8** Tighten the screws that secure the fan tray to the chassis.
- Step 9** Reinstall the access panel.
- Step 10** Reinstall the top cover panel by aligning it over the balled posts and snapping it in place.
- Step 11** For additional instructions, refer to [Returning Failed Components](#), on page 147.

**Figure 27: Upper Fan Tray Replacement**

## Replacing Front Fan Trays

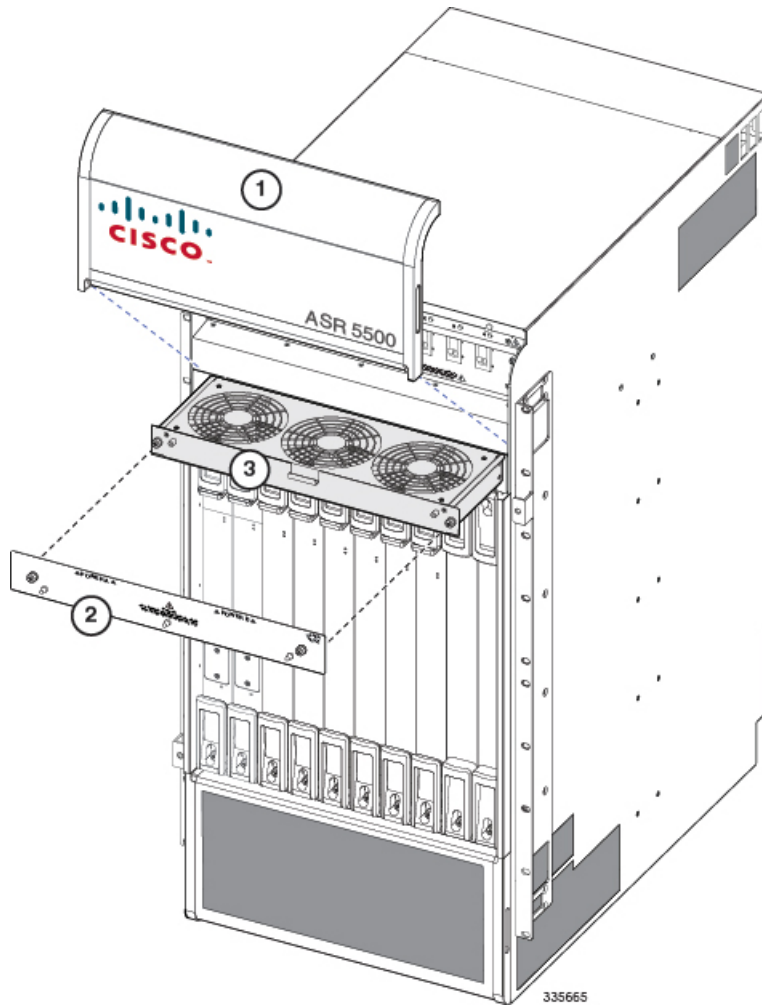

|   |                |   |              |
|---|----------------|---|--------------|
| 1 | Cover panel    | 2 | Access Cover |
| 3 | Front fan tray |   |              |

## Replace the Lower Fan Tray

- 
- Step 1** Remove the cover panel from the bottom of the chassis. Firmly grasp the side edges of the panel and pull up and away to unsnap the panel. Put the panel safely aside.
- Step 2** Loosen the screws and remove the fan tray access panel from the chassis. Place it safely aside.
- Step 3** Use a #1 Phillips screwdriver to loosen the two screws that secure the handle to the front of the fan tray.
- Step 4** Flip up and grasp the fan tray handle and pull. Support the bottom of the fan tray unit with one hand as you pull it away from the chassis.
- Step 5** Place the failed fan tray unit safely aside.
- Step 6** Align the replacement fan tray within the lower chassis opening. With the unit resting on the bottom rail of the opening, push inward until it is firmly seated in the rear connectors. If the ASR 5500 is powered up, the fans should begin spinning.
- Step 7** Reinstall the access panel.
- Step 8** Reinstall the bottom cover panel by aligning it over the balled posts and snapping it in place.
- Step 9** For additional instructions, refer to [Returning Failed Components](#), on page 147.
- 

## Replacing Rear Fan Trays



### Caution

Fan tray units contain multiple fans that spin at a high rate of speed when the system is powered on. If the system is powered on when a fan tray is removed, do not touch moving fans. To minimize the risk of personal injury and potential equipment damage, pull the fan tray towards you until the fan tray extends out of the chassis approximately two inches (5 cm). Wait a few seconds to allow fans to spin down before fully removing the fan tray.

---



### Important

Removing a rear fan tray will cause its companion front fan tray to power down. The front fan tray will power back up when the rear tray is replaced.

---



### Important

Have the replacement fan tray available and ready to be installed before starting the replacement procedure.

---

## Replace the Upper Fan Tray

---

- Step 1** At the rear of the chassis, remove the cover panel below the vent panel at the top of the chassis. Firmly grasp the side edges of the panel and pull up and away to unsnap the panel. Put the panel safely aside.
- Step 2** Loosen the knurled screws and remove the upper fan tray access panel from the chassis. Place it safely aside.
- Step 3** Use a #1 Phillips screwdriver to loosen the two screws that secure the fan tray to the chassis.
- Step 4** Grasp screw posts on the ends of the unit and pull the failed fan tray unit from the chassis.
- Step 5** Place the failed fan tray unit safely aside.
- Step 6** Align the replacement fan tray within the upper chassis opening. With the unit resting on the bottom rail of the opening, push inward until the rear connector is firmly seated in the midplane. If the ASR 5500 is powered up, the fans should begin spinning.
- Step 7** Tighten the screws that secure the fan tray to the chassis.
- Step 8** Reinstall the access panel.
- Step 9** Reinstall the top cover panel by aligning it over the balled posts and snapping it in place.
- Step 10** For additional instructions, refer to [Returning Failed Components, on page 147](#).
-

## Replace the Lower Fan Tray

**Important**

If your chassis is equipped with a cable management tray, the tray must be in the up and latched position to remove the lower fan tray. Refer to *Raising the Cable Management Tray* section in the *Cable Management System Installation* appendix.

- 
- Step 1** Remove the cover panel from the bottom of the chassis. Firmly grasp the side edges of the panel and pull up and away to unsnap the panel. Put the panel safely aside. See the figure below.
  - Step 2** Loosen the screws and remove the fan tray access panel from the chassis. Place it safely aside.
  - Step 3** Use a #1 Phillips screwdriver to loosen the two knurled screws that secure the handle to the front of the fan tray.
  - Step 4** Flip up and grasp the fan tray handle and pull. Support the bottom of the fan tray unit with one hand as you pull it away from the chassis.
  - Step 5** Place the failed fan tray unit safely aside.
  - Step 6** Align the replacement fan tray within the lower chassis opening. With the unit resting on the bottom rail of the opening, push inward until the rear connector is firmly seated in the midplane. If the ASR 5500 is powered up, the fans should begin spinning.
  - Step 7** Tighten the screws that secure the fan tray to the chassis.
  - Step 8** Reinstall the access panel.
  - Step 9** Reinstall the bottom cover panel by aligning it over the balled posts and snapping it in place.
  - Step 10** For additional instructions, refer to [Returning Failed Components](#), on page 147.

**Figure 28: Lower Fan Tray Replacement**

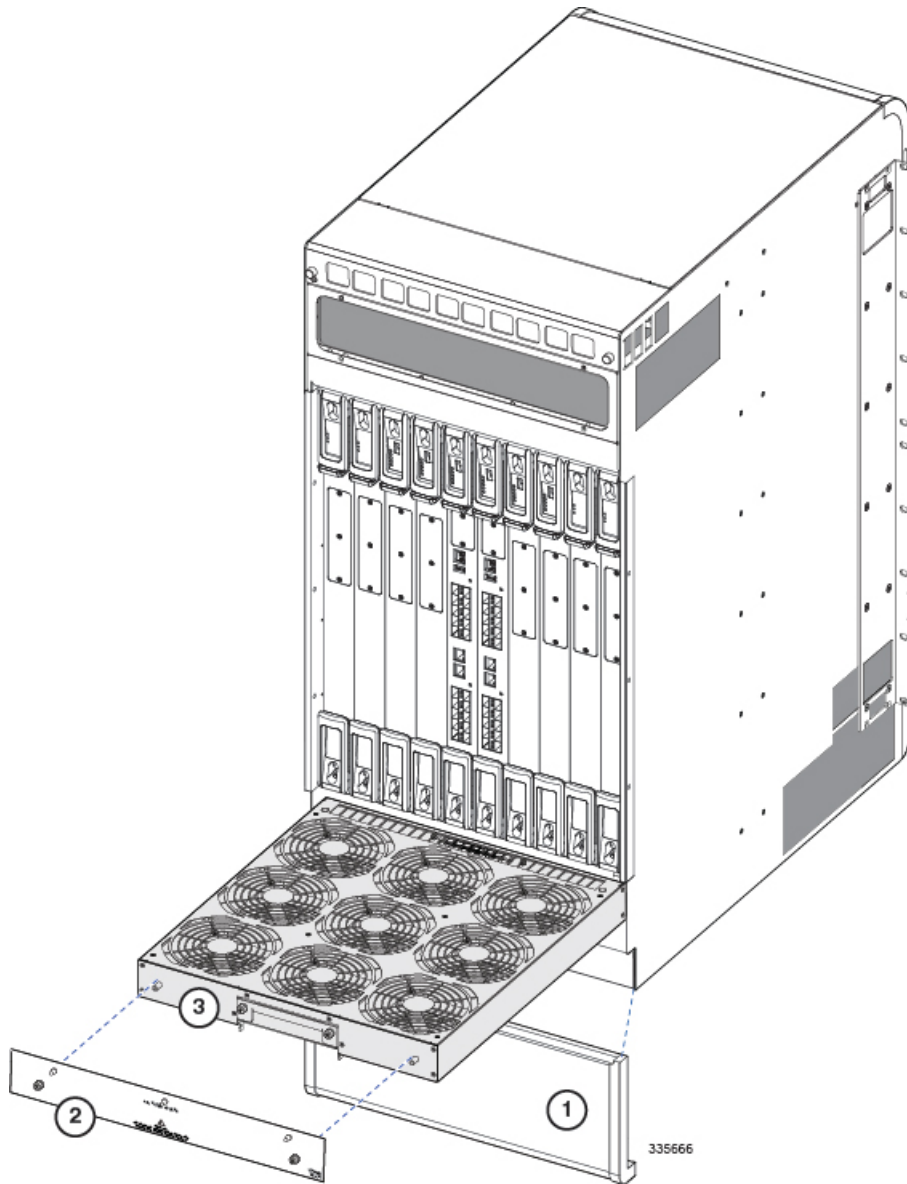

|   |               |   |              |
|---|---------------|---|--------------|
| 1 | Cover panel   | 2 | Access Cover |
| 3 | Rear fan tray |   |              |

# PFU

**Caution**

Although a single PFU can provide power for a fully loaded chassis, it is strongly recommended that two fully functional PFUs always be installed for load-balancing and redundancy.

## Determining that a PFU has Failed

There are several mechanisms to indicate a PFU failure.

- Run the **show power** command from the CLI.
- Verify that all circuit breakers are in the ON position. The four blue LEDs should be ON.
- Verify that the RTN and -48VDC lugs are securely attached to all posts at the upper rear of the chassis.
- Verify that the ground lugs are securely attached to the posts on the bottom rear of the chassis.
- Use a voltmeter to verify that the power distribution panel is supplying the correct voltage and sufficient current to the terminals at the rear of the PFU.
- Check the cables from the power source to the rack for continuity.

If all of the above checks fail to isolate a fault, you may assume that the PFU has failed.

## Replacing a PFU

In the event of a PFU failure, follow these instructions to safely remove the PFU from the system.

**Step 1** At the upper front of the chassis, unsnap and remove the cover over the front of the PFUs. See figure below.

**Step 2** Power down the failed PFU by setting the four circuit breakers at the front of the PFU to OFF (O).

**Step 3** At the power distribution panel, turn OFF the four power feeds going to the failed PFU.

**Step 4** Remove all the power feed cables from the terminals at the rear of the PFU.

**Caution** Trying to remove a PFU with one or more of the rear cables still attached may cause severe damage to the PFU and other chassis components.

**Important** All cables going to the PFU should be labeled with the PFU terminal number and power distribution panel circuit number.

- a) Loosen the screws and remove the plastic terminal cover.
- b) Use a 7/16-inch nut driver or socket wrench to remove the nuts, lock washers and flat washers from each of the eight terminals and set them aside for reuse.

c) Remove the 2-hole lugs from each of the terminals.

- Step 5** From the front of the chassis, use a Phillips #2 screwdriver to loosen the four screws securing the failed PFU to the chassis.
- Step 6** Grasp the handle on the front of the PFU and pull forcefully downward to extract the PFU from the power plane connectors. Pull the unit from the chassis and set it aside.
- Step 7** Verify that the four circuit breakers on the front of the replacement PFU are in the OFF (O) position. the handle on the front of the PFU should be in the down position.
- Step 8** Slide the replacement PFU into the PFU bay until it is flush against the rear connectors. Firmly push the PFU into the power plane connectors. Pull the handle forcefully upwards to fully seat the PFU into the power plane connectors.
- Step 9** Use a Phillips #2 screwdriver to tighten each of the four screws on the PFU to secure it to the chassis.
- Step 10** At the rear of the chassis replace the power feed cables on the PFU input terminals.
- Before proceeding, verify that the bottom nuts on all terminals are torqued to 50 in-lb. (5.65 N-m).
  - Thread each cable through an opening in the side of the chassis and route it to the appropriate terminals (-48V 1, Return 1, -48V 2, Return 2, etc.).
  - Install each lug over the two terminals.
  - Secure each lug to the terminals with flat washers, lock washers and nuts. The nuts should be torqued to 8 in-lb. (0.9 N-m).
  - Continue installing the feeds on the terminals until all power feed connections have been completed to the replacement PFU.
- Caution** To avoid the risk of fire verify that the supply and return lugs are not touching.
- Step 11** Turn ON the four power feeds from the power distribution panel to the PFU.
- Step 12** At the front of the chassis, power up the PFU by setting the four circuit breakers on its front panel to ON (|). The four blue LEDs should be ON.
- Step 13** Reinstall the plastic terminal cover on the top-rear of the chassis.
- Caution** To avoid the risk of personal injury and/or potential damage to the system, never operate the chassis without the plastic cover.



**Step 14** Reinstall the front top cover panel by aligning it over the balled posts and snapping it in place.

**Step 15** For additional instructions, refer to [Returning Failed Components](#), on page 147.

**Figure 29: PFU Replacement**

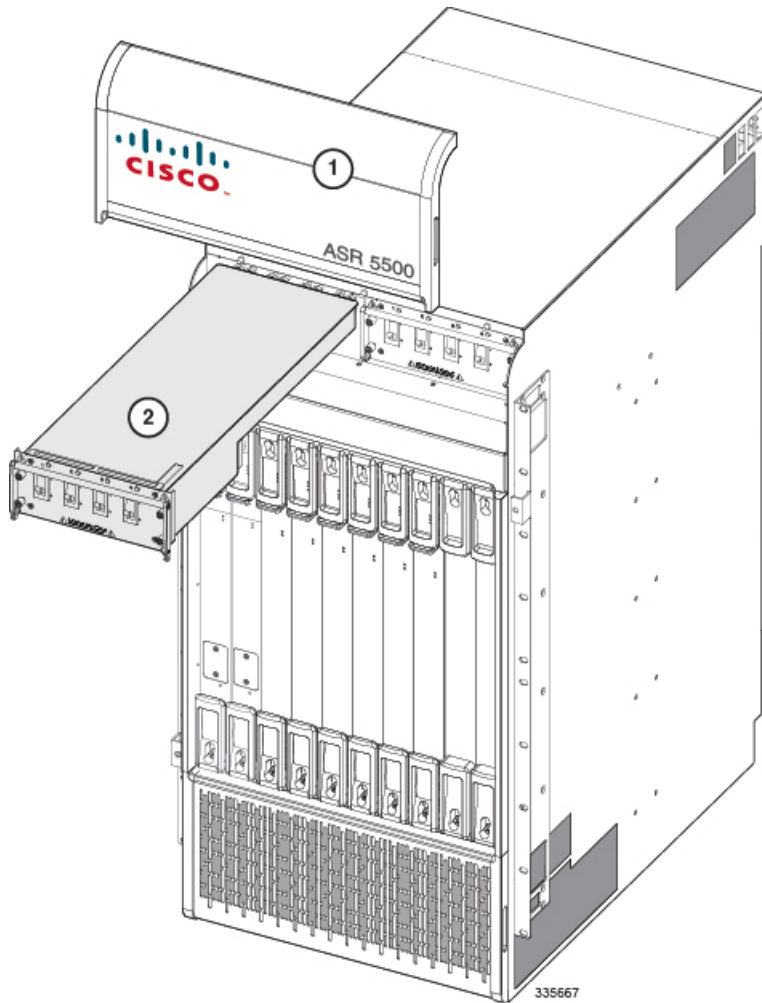

|   |             |   |     |
|---|-------------|---|-----|
| 1 | Cover panel | 2 | PFU |
|---|-------------|---|-----|

## Circuit Cards

This section describes how to replace circuit cards in the ASR 5500 chassis.

## Determining Whether a Card has Failed

The ASR 5500 has several ways to indicate an application card failure. The first indicator is that the Status LED on the System Status Card (SSC) turns red to indicate the failure of a chassis component. Another indicator is the Run/Fail LED on an application card is red or turns off if that card has a problem.

If you see either of these indicators, you can determine the nature of the problem by using the CLI or checking the Simple Network Management Protocol (SNMP) traps that may have been generated.

### show card diag Command

Execute the **show card diag slot\_#** command from the CLI in Exec mode. *slot\_#* is the chassis slot number in which the particular card that you wish to monitor is installed. The following is a sample output for this command to monitor the card in chassis slot 5:

```
[local]asr5500# show card diag 5

Card 5:
Counters:
  Successful Warm Boots : 0
                        (last at Friday July 29 13:45:58 us-eastern 2011)
  Successful Cold Boots : 2
                        (last at Friday July 29 13:46:20 us-eastern 2011)
  Total Boot Attempts   : 1
  In Service Date       : Fri Jul 29 13:50:58 2011

Status:
  IDEEPROM Magic Number : Good
  Boot Mode               : Normal
  Card Diagnostics       : Pass
  Current Failure        : None
  Last Failure           : None
  Card Usable            : Yes

Current Environment:
  Temp: DDR-C0D0         : 30.00 C (limit 100.00 C)
  Temp: DDR-C0D1         : 30.00 C (limit 100.00 C)
  Temp: DDR-C1D0         : 30.00 C (limit 100.00 C)
  Temp: DDR-C1D1         : 30.00 C (limit 100.00 C)
  Temp: DDR-C2D0         : 30.00 C (limit 100.00 C)
  Temp: DDR-C2D1         : 30.00 C (limit 100.00 C)
  Temp: CPU-N0C0         : 30.00 C (limit 101.00 C)
  Temp: CPU-N0C1         : 30.00 C (limit 101.00 C)
  Temp: CPU-N0C2         : 30.00 C (limit 101.00 C)
  Temp: CPU-N0C3         : 30.00 C (limit 101.00 C)
  Temp: CPU-N0C4         : 30.00 C (limit 101.00 C)
  Temp: CPU-N0C5         : 30.00 C (limit 101.00 C)
  Temp: IOH              : 35.00 C (limit 110.00 C)
  Temp: NP4 #0           : 35.00 C (limit 115.00 C)
  Temp: NP4 #1           : 35.00 C (limit 115.00 C)
  Temp: NP4 #2           : 35.00 C (limit 115.00 C)
  Temp: NP4 #3           : 35.00 C (limit 115.00 C)
  Temp: LM94             : 0.00 C
  Temp: Petral           : 35.00 C (limit 100.00 C)
  Temp: Petra2           : 35.00 C (limit 100.00 C)
  Temp: Upper-right      : 27.50 C (limit 85.00 C)
  Temp: Petra3           : 35.00 C (limit 100.00 C)
  Temp: Petra4           : 35.00 C (limit 100.00 C)
  Temp: Mid-right        : 27.50 C (limit 85.00 C)
  Temp: MDF              : 25.00 C (limit 80.00 C)
  Temp: Lower-right      : 22.50 C (limit 75.00 C)
  Temp: Upper-left       : 27.50 C (limit 85.00 C)
  Temp: Lower-left       : 27.50 C (limit 85.00 C)
  Temp: DC1              : 27.50 C (limit 85.00 C)
  Temp: DC2              : 27.50 C (limit 85.00 C)
  Temp: F600 #1         : 0.00 C
  Temp: F600 #2         : 0.00 C
```

```

Voltage: 12V-A           : 0.000 V
Voltage: CPU0 VTT       : 1.136 V (min 0.992 V, max 1.281 V)
Voltage: 12V-B         : 0.000 V
Voltage: 12V-C         : 0.000 V
Voltage: 1.8V          : 1.800 V (min 1.700 V, max 1.900 V)
Voltage: 1.5V          : 1.505 V (min 1.430 V, max 1.580 V)
Voltage: CPU0 VCC      : 1.064 V (min 0.712 V, max 1.417 V)
Voltage: 1.2V          : 1.200 V (min 1.140 V, max 1.260 V)
Voltage: 3.3V          : 3.305 V (min 3.140 V, max 3.470 V)
Voltage: 5V            : 5.000 V (min 4.750 V, max 5.250 V)
Voltage: 3.0V Batt     : 0.000 V
Voltage: 2.5V          : 2.505 V (min 2.380 V, max 2.630 V)
Voltage: 1.53V DDR0    : 1.444 V (min 1.282 V, max 1.606 V)
Voltage: 7.5V          : 7.505 V (min 7.130 V, max 7.880 V)
Voltage: 1.1V IOH      : 1.099 V (min 1.045 V, max 1.155 V)
Voltage: 3.3V Stdby    : 3.300 V (min 2.970 V, max 3.630 V)
Voltage: 48V-A         : 0.000 V
Voltage: 48V-B         : 0.000 V
Current: 48V-A         : 0.00 A
Current: 48V-B         : 0.00 A
Airflow: Lower Left   : 0 FPM
Airflow: Lower Middle : 0 FPM

```

## SNMP Traps

The ASR 5500 supports SNMP traps that are triggered when conditions indicate status changes on application cards.

To display SNMP trap statistics, run the **show snmp trap statistics** command. A sample output appears below.

```

[local]asr5500# show snmp trap statistics
SNMP Notification Statistics:
  Total number of notifications      : 13
  Last notification sent             : Friday July 29 13:46:38 us-eastern 2011
  Notification sending is           : enabled
  Notifications have never been disabled
  Notifications have never been cleared
  Notifications in current period    : 0
  Notifications in previous period   : 0
  Notification monitor period        : 300 seconds

Trap Name                #Gen  #Disc  Disable  Last Generated
-----
CardUp                   4      0      0  2011:07:29:13:46:35
PortLinkDow              2      0      0  2011:07:29:13:46:38
CLISessStart             1      0      0  2011:07:29:13:46:37
CardActive               1      0      0  2011:07:29:13:46:20
CardStandby              3      0      0  2011:07:29:13:46:35
PortDown                 2      0      0  2011:07:29:13:46:38

Total number of notifications Disabled : 0

```



---

**Important** Run the **show snmp trap history** command to view recently sent SNMP traps.

---

## Replacing Universal Cards

UMIO cards, UDPCs and UDPC2s are functional replacements for MIOs, DPCs and DPC2s. However, special chassis and card licenses may be required in order for the UMIO, UDPC or UDPC2 to operate. For additional information, refer to *Chassis Universal License Requirements*.

**Important**

---

Data processing cards must all be of the same type – DPC, UDPC, DPC2 or UDPC2 – in a chassis.

---

## Backing Up the System Configuration

Prior to replacing a failed card of any type, it is good practice to save the current configuration to an external USB device or remote network location.

Refer to *Verifying and Saving Your Configuration* in the *System Administration Guide* for detailed instructions

## Synchronize File System

To assure that the configuration files on both MIO/UMIOs are identical, run the Exec mode **filesystem synchronize all** command.

```
[local]host_name# filesystem synchronize all
```

## Preparing a Card for Replacement

To minimize service disruptions, traffic currently being processed by a failing or failed circuit card should be switched to another card. You have the following options based on the type of card being replaced:

- **MIO/UMIO** – If the active MIO/UMIO fails, a switchover to the standby MIO/UMIO is automatic. In the event that an issue arises that is not severe enough for the system to perform an automatic switchover, a manual switchover can be invoked by executing the Exec mode **card switch from <5 or 6> to <6 or 5>** command.
- **DPC/UDPC and DPC2/UDPC2** – An Exec mode **card busy-out slot\_number** command moves processes from the source DPC/UDPC to the destination DPC/UDPC, or disables the DPC/UDPC from accepting any new calls. When busy-out is enabled, the DPC/UDPC stops receiving new calls but continues to process calls until they are completed. The busy-out procedure is completed in background.
- **DPC/UDPC and DPC2/UDPC2** – In the event of the critical failure of a DPCx/UDPCx, tasks will be automatically be migrated from the active card to a redundant card in standby mode. In the event that an issue arises that is not severe enough for the system to perform an automatic migration, a manual migration can be initiated using the Exec mode **card migration from original\_slot# to final\_slot#**
- **FSC** – The FSCs are configured for n+1 redundancy. When an active FSC fails, an automatic switchover is made to the standby FSC. At least one FSC must be in standby mode prior to initiating a switchover. In the event that an issue arises that is not severe enough for the system to perform an automatic switchover, a manual switchover can be invoked by executing the Exec mode **card switch from slot\_number to slot\_number** command.

**Important**

---

An FSC-200GB (equipped with two 200GB SSDs) can be replaced with an FSC-400GB (equipped with a single 400GB SSD) only if the StarOS release supports the non-RAID 0 configuration of the FSC-400GB.

---

Cards other than MIO/UMIO that are in either the Active or Standby modes should be halted prior to removal. Halting these cards places them into the "offline" mode. In this mode, the card is unusable for session processing as either an active or redundant component. If a card in the active mode is halted, its tasks, processes, or network connections will be migrated or switched to a redundant component prior to entering the offline mode.

Initiate a manual card migration by entering the Exec mode **card halt slot#** command.

Verify that the migration was successful by entering the Exec mode **show card table** command. Check the entry in the Oper State column next to the card that was just halted. Its state should be Offline. If the card was in active mode prior to the execution of this command, the state of the redundant component associated with it should now be Active.

All status LEDs on the halted card should be OFF when a card is offline and ready to be replaced.

**Caution**

Attempting to replace a circuit card that has not been taken offline may result in spurious error messages and unexpected behavior that may initiate reload of other cards.

For additional information about the above commands and procedures, refer to the *Command Line Interface Reference* and the *Troubleshooting* section of the *System Administration Guide*.

## Replacing a Failed Card

This section describes how to remove and replace a failed circuit card.

**Important**

Circuit cards can be replaced while the ASR 5500 is operating.

**Important**

The optical SFP+ interfaces on the MIO/UMIO comply with the limits for Class 1 laser devices for IEC825, EN60825, and 21CFR1040 specifications.

**Important**

If the chassis in which the card is to be replaced interfaces via SRP with a peer chassis for Interchassis System Recovery (ICSR), the chassis to receive the replacement card must be placed in SRP Standby. Verify its current state by running the Exec mode **show srp info** command. Refer to the *System Administration Guide* for instructions.

**Caution**

During installation, maintenance, and/or removal, wear a grounding wrist strap connected to the ASR 5500 chassis to avoid ESD damage to the components. Failure to do so could result in damage to sensitive electronic components and potentially void your warranty.

## Remove I/O Connections (MIO/UMIO and SSC)



### Important

To facilitate removal and reconnection, all I/O cables should be labeled with their terminating destinations prior to removal.

### MIO or UMIO



### Important

If your ASR 5500 chassis is equipped with a cable management system, refer to the special instructions for *Detaching Network Cables from the Card Bracket* in the *Cable Management System Installation* appendix.

**Step 1** Unplug the cable connected to the RJ45 serial Console port.

**Step 2** Unplug any cables connected to the RJ45, 1 GbE ports.

**Step 3** If necessary, remove a USB memory stick from the USB port.

**Step 4** Remove the fiber optic cables connected to 10 GbE ports on the daughter card(s). Install dust caps on the ends of the fiber optic cables.

**Important** Do not remove the transceivers from MIO/UMIO ports. Replacement MIO/UMIO cards are shipped with replacement transceivers already installed.

### SSC

**Step 1** Disable the CO alarms from the SSC at the alarm monitoring panel.

**Step 2** Remove the DB15 connector from the SSC alarm port, if necessary.

## Remove and Replace the Circuit Card



### Caution

Do not leave chassis slots uncovered for extended periods of time (more than a few minutes). This reduces air flow through the chassis and could cause overheating. Make sure a card or baffle is installed in every unpopulated chassis slot at all times.

**Important**

If your ASR 5500 chassis is equipped with a cable management system, refer to the special instructions for *Lowering the Cable Management Tray* in the *Cable Management System Installation* appendix.

**Caution**

All status LEDs on the failed card should be OFF prior to removing the card from the chassis. See [Preparing a Card for Replacement](#), on page 140.

- 
- Step 1** Use a Phillips #2 screwdriver to loosen the captive screws within the top and bottom handles of the failed card. See figure below.
- Step 2** Slide the blue subhandle underneath the top handle downward to unlock the handle and disable the card interlock switch.
- Step 3** Simultaneously pull both card handles firmly outward until the card is unseated from the midplane connectors.
- Step 4** Firmly grasp the top and bottom edges of the card and pull the card slowly out of the chassis. Set the failed card safely aside.
- Step 5** If an MIO/UMIO is being replaced, refer to [Swapping the SDHC Memory Card](#), on page 144, and swap the SDHC memory card from the failed MIO/UMIO into the replacement MIO/UMIO.
- Step 6** Flip the top and bottom handles of the replacement card fully outwards.
- Step 7** Holding the card by the top and bottom edges of the front panel, align the card with the upper and lower card guides of the chassis slot. Gently slide the card into the slot until the handles touch the card cage rails.
- Step 8** Simultaneously push the top and bottom handles firmly inward until the card is fully seated in the midplane connectors. Press firmly on the card's faceplate to ensure that it is fully seated. The front panel should be flush against the chassis upper and lower card mounts for the slot.
- Step 9** Slide the blue subhandle under the top handle to lock the handle in place and enable the interlock switch.
- Step 10** Use a Phillips #2 screwdriver to tighten the captive screws within the top and bottom handles of the card.
- Step 11** For each MIO/UMIO daughter card, firmly press the SFP+ transceivers inwards and reconnect the fiber optic cables.
- Step 12** Reconnect any other I/O cables that may have been removed from the failed card.
- Important** Connectors on the fiber optic cables must be free of dust, oil, or other contaminants. Before connecting the cable to the transceiver, carefully clean the connectors as described in [Cleaning Fiber Optic Connectors](#), on page 146.
- Important** If your ASR 5500 chassis is equipped with a cable management system, refer to the special instructions for *Reconnecting Network Cables to the Card Bracket* and *Raising the Cable Management Tray* in the *Cable Management System Installation* appendix.

- Step 13** A circuit card will automatically initiate a Power On Self Test (POST) upon insertion into the backplane. If the POST is successfully completed, the card will reload (reboot) itself. Refer to the *Verifying System Startup* section in the *System Power-up* chapter for additional information.
- Step 14** From the CLI run the Exec mode **filesystem synchronize all** command.
- Step 15** Back up the system configuration. Refer to [Backing Up the System Configuration](#), on page 140.
- Step 16** For additional instructions, refer to [Returning Failed Components](#), on page 147.

**Figure 30: Circuit Card Replacement**

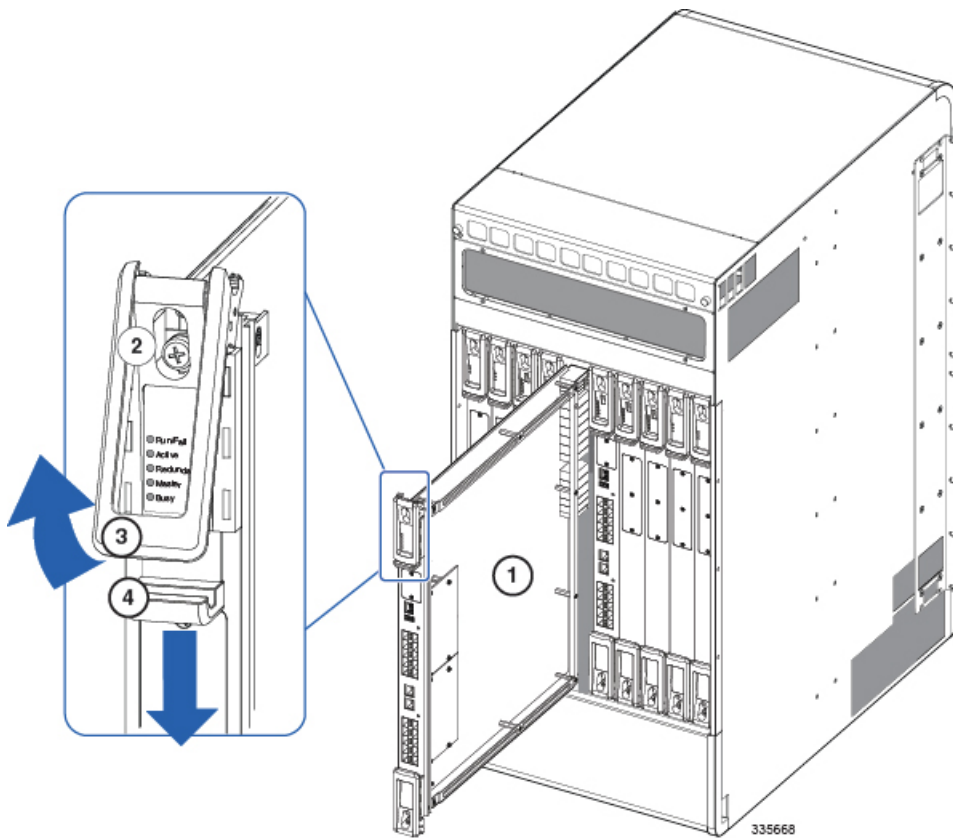

|   |                |   |                   |
|---|----------------|---|-------------------|
| 1 | Circuit card   | 2 | Phillips #2 Screw |
| 3 | Ejector handle | 4 | Ejector subhandle |

## Swapping the SDHC Memory Card

The SDHC memory card on the MIO/UMIO appears as the /flash drive on the CLI. The /flash drive stores configuration data, including the boot priority settings.



**Caution**

Removal and replacement of the SDHC card must be performed at an ESD-safe workstation. Observe ESD precautions when handling the SDHC card and MIO/UMIO cards.

**Step 1**

On a failed MIO/UMIO, locate the SDHC card in the bottom rear corner of the circuit card (see figure below).

**Figure 31: MIO/UMIO SDHC Card Location**

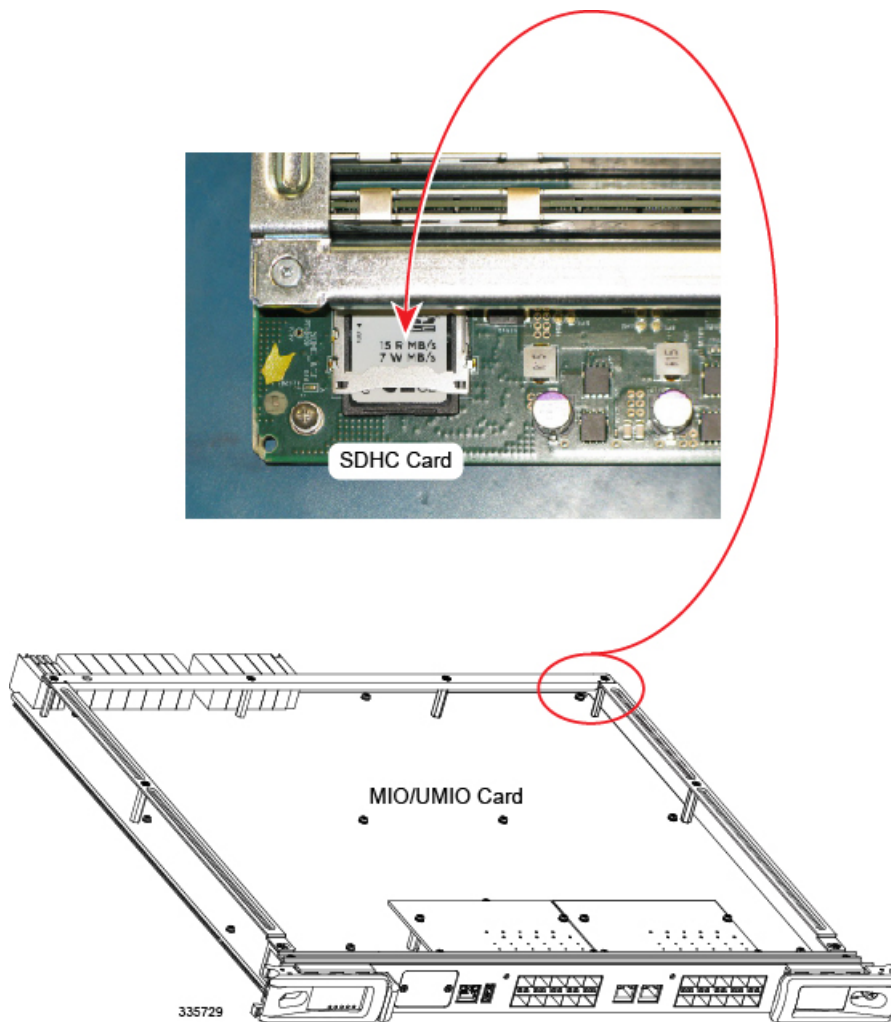

- Step 2** The SDHC card resides in a push-push type holder. With your finger tip, push the rear edge of the SDHC card inward until you hear a click. Release your finger and the card will pop out of the holder. Remove the card and store it safely aside.
- Step 3** On the replacement MIO/UMIO, locate the SDHC card holder and remove the SDHC card. That card contains only a basic configuration for testing purposes; insert it into the failed card prior to returning the circuit card to Cisco.
- Step 4** On the replacement MIO/UMIO, insert the SDHC card removed from the failed MIO/UMIO. With your finger tip, push the SDHC card inward until you hear a click and release your finger.  
This completes the SDHC card swap out procedure.
- 

## Cleaning Fiber Optic Connectors

Fiber optic connectors join optical fibers together. They can be damaged by improper cleaning and connection procedures. Dirty or damaged fiber optic connectors can degrade communication.

In a fiber optic system, light is transmitted through extremely small fiber cores. Because fiber cores are often 62.5 microns or less in diameter, and dust particles range from a tenth of a micron to several microns in diameter, dust and any other contamination at the end of the fiber core can degrade the performance of the connector interface where the cores meet. Therefore, the connector must be precisely aligned and the connector interface must be absolutely free of foreign material.

Connector loss, or insertion loss, is a critical performance characteristic of a fiber optic connector. Return loss is also an important factor. Return loss specifies the amount of reflected light: the lower the reflection, the better the connection. The best physical contact connectors have return losses of better than  $-40$  dB, but  $-20$  to  $-30$  dB is more common.

The connection quality depends on two factors: the type of connector and the proper cleaning and connection techniques. Dirty fiber connectors are a common source of light loss. Keep the connectors clean at all times, and keep the dust plugs or covers installed when the connectors are not in use.

As a general rule, any time you detect a significant, unexplained loss of light, clean the connectors. To clean the optical connectors, obtain and use a fiber optic cleaning kit and follow the manufacturer's usage instructions. Clean the ferrule, the protective tube or cone that surrounds the fiber core, and the end-face surface of the fiber core.

If a cleaning kit is not available, follow these steps:

- 1 Use a lint-free tissue soaked in 99 percent pure isopropyl alcohol and gently wipe the end-face of the fiber core. Wait for five seconds for the surfaces to dry and wipe the surfaces a second time.
- 2 Use clean, dry, oil-free compressed air to remove any residual dust from the connector.
- 3 Use a magnifying glass or inspection microscope to inspect the ferrule at angle. Do not look directly into the aperture. If you detect any contamination, repeat Steps 1 and 2.

**Caution**

Because invisible laser radiation may be emitted from the aperture of the port when no cable is connected, avoid exposure to laser radiation and do not stare into open apertures.

---

# Returning Failed Components

If the failed component is still under Cisco warranty or a hardware maintenance contract, return it for repair or replacement.

If the failed component is out of warranty or not covered by a maintenance contract, contact Cisco to determine if it can be sent in for repair at an additional cost.

Please contact your local Cisco sales or service representative for additional information.

**Caution**

---

Use a saved shipping carton and anti-static bag when returning a circuit card to Cisco for fault analysis. Failure to use the proper packaging will make it impossible to isolate problems resulting from physical or ESD damage during shipping. For additional information see the *RMA Shipping Procedures* appendix.

---

**Important**

---

SFP+ transceivers must be returned along with MIO/UMIO cards. Leave the fiber optic devices installed in the card.

---

**Important**

---

Disposal of this product should be performed in accordance with all national laws and regulations.

---





## APPENDIX A

# Spare Component Recommendations

This appendix identifies the recommended type and number of spare components required to support the ASR 5500.

This appendix includes the following sections:

- [Spare Component Recommendations](#), page 149

## Spare Component Recommendations

This appendix provides a recommended quantity of spare components to be stocked as part of a sparing program for the ASR 5500. This information should only be used as a guideline for designing a sparing program that meets your company's design, deployment, and availability goals.



**Important** Only fully-trained personnel, on-site or field engineering resources should exchange the Field Replaceable Units (FRUs) listed below.

Based on industry-leading redundancy and failover features incorporated within the system, Cisco recommends that the following minimum spare parts levels for any ASR 5500 deployment.

**Table 24: Recommended FRU Parts Sparing Quantities**

| Component Name                    | Notes | Min. No. of Spares | Per "n" components |
|-----------------------------------|-------|--------------------|--------------------|
| <b>Chassis</b>                    |       |                    |                    |
| ASR 5500 Chassis, Base Components | 1     | 1                  | 20                 |
| ASR 5500 Chassis with Midplane    | 2     | 1                  | 20                 |
| Power Filter Unit (PFU)           | —     | 1                  | 30                 |
| Fan Tray Unit, Front              | —     | 1                  | 8                  |
| Fan Tray Unit, rear               | —     | 1                  | 8                  |

| Component Name                                                                   | Notes | Min. No. of Spares | Per "n" components |
|----------------------------------------------------------------------------------|-------|--------------------|--------------------|
| Air Filters, Front and Rear Air                                                  | —     | 1                  | 1                  |
| <b>Rear Cards</b>                                                                |       |                    |                    |
| Management Input/Output (MIO) with two 10 X 10GBASE-LR daughter cards            | 3     | 1                  | 10                 |
| Management Input/Output Universal (UMIO) with two 10 X 10GBASE-LR daughter cards | 3, 4  | 1                  | 10                 |
| Management Input/Output (MIO) with two 10 X 10GBASE-SR daughter cards            | 5     | 1                  | 10                 |
| Management Input/Output Universal (UMIO) with two 10 X 10GBASE-SR daughter cards | 4, 5  | 1                  | 10                 |
| Data Processing Card (DPC)                                                       | —     | 1                  | 12                 |
| Data Processing Universal Card (UDPC)                                            | 6     | 1                  | 12                 |
| Data Processing Card v2 (DPC2)                                                   | 7     | 1                  | 12                 |
| Data Processing Universal Card v2 (UDPC2)                                        | 7, 8  | 1                  | 12                 |
| <b>Front Cards</b>                                                               |       |                    |                    |
| Fabric and Storage Card (FSC)                                                    | —     | 1                  | 30                 |
| System Status Card (SSC)                                                         | —     | 1                  | 30                 |
| <b>Miscellaneous</b>                                                             |       |                    |                    |
| Lug Kit (power and ground)                                                       | —     | 1                  | 30                 |

## Notes:

- 1 Includes: (2) PFUs, front upper and lower fan tray units, rear upper and lower fan tray units, front and rear air filters.
- 2 Does not include PFUs, fan tray units or air filters.
- 3 Includes (20) 10GBASE-LR SFP+ modules.
- 4 Direct replacement for MIO card; requires U-PID license per installed UMIO. See *Chassis Universal License Requirements* for additional information.
- 5 Includes (20) 10GBASE-SR SFP+ modules.
- 6 Direct replacement for DPC; requires U-PID license per installed UDPC. See *Chassis Universal License Requirements* for additional information.
- 7 The DPC2/UDPC2 is not interchangeable with a DPC/UDPC.
- 8 Direct replacement for DPC2; requires U-PID license per installed UDPC2. See *Chassis Universal License Requirements* for additional information.



## Chassis Universal License Requirements

This appendix describes the requirements for "universal" licenses that support Management I/O Universal (UMIO) and Data Processing Universal (UDPC/UDPC2) card types. It also explores UMIO and UDPC/UDPC2 behavior in non-universal chassis or in chassis with a mix of non-universal MIOs and DPC/DPC2s, and UMIOs and UDPC/UDPC2s.



### Important

Contact your Cisco account representative for detailed information regarding ASR 5500 license requirements.

This appendix addresses the following topics:

- [License Types, page 151](#)
- [StarOS License Support Matrices, page 152](#)
- [Updating A Chassis License for Universal Cards, page 153](#)

## License Types

A chassis software license that enables universal card support is required when UMIOs and/or UDPC/UDPC2s are installed. This license also specifies the maximum number of UDPC/UDPC2s that can run on the chassis at the same time. Both active and standby UDPC/UDPC2s are counted against the maximum UDPC/UDPC2 limit.



### Important

UDPCs and UDPC2s must never be mixed in the same chassis. Data processing cards must all be of the same type in a chassis. UDPC2s require StarOS Release 18.2+.

The system automatically prevents a UDPC/UDPC2 from running if the maximum number of UDPC/UDPC2s specified by the chassis license has been reached. If the maximum number of UDPC/UDPC2s are running and there are additional UDPC/UDPC2s in the system, the system will automatically run another UDPC/UDPC2 only when one of the currently running UDPC/UDPC2s goes offline or restarts. However, the system will not bring down currently active UDPC/UDPC2s due to an insufficient number of UDPC/UDPC2s specified in the license.

To add one or more UDPC/UDPC2 to an ASR 5500 chassis where the number of allowed UDPC/UDPC2s has been reached, you must update the chassis license to increase the number of supported cards. See [Updating A Chassis License for Universal Cards](#), on page 153.

Universal cards and non-universal cards have the same capacity and can backup each other for redundancy. For example, a UMIO can be the standby of an MIO and will transition to active when the active MIO fails. Tasks running on a DPC or DPC2 can be migrated to a standby UDPC or UDPC2 and vice versa.

Different combinations of licenses for universal cards and non-universal cards are supported in an ASR 5500 chassis. Some combinations may cause the system to be only partially operational or entirely non-operational.

License types include:

- **Non-Universal** – support for universal cards is not enabled. Non-universal licenses include those issued before universal cards became available.
- **Universal** – support for UMIO or UDPC/UDPC2 is enabled.
- **Mix** – support for both universal and non-universal cards exists.
- **None** – the particular license type is missing from the system. No license is the same as having a universal license.
- **Any** – For MIO or DPC, this is all combinations of the above four license types: Non-Universal, Universal, Mix and None. For a chassis license this is either Universal, Non-Universal or None.

License changes or card changes may cause the system to change from one combination to another combination. The default chassis license supports universal cards. A chassis with no license will support universal cards without a limit for the maximum number of UDPC/UDPC2s.

## StarOS License Support Matrices

The tables below describes system behavior based on license type, universal card type mix, and StarOS universal card support.

**Table 25: License Support Matrix for StarOS Version with Universal Card Support**

| Chassis         | MIO/UMIO      | DPC/UDPC or DPC2/UDPC2           | System Behavior                                                                                                                                   |
|-----------------|---------------|----------------------------------|---------------------------------------------------------------------------------------------------------------------------------------------------|
| Universal, None | Any           | Any                              | All cards are recognized and boot. The system will not be able to enable services when there is no license.                                       |
| Non-Universal   | Non-Universal | Non-Universal                    | All cards recognized and boot.                                                                                                                    |
| Non-Universal   | Non-Universal | Non-Universal, Universal or None | UDPC/UDPC2s will fail to boot.                                                                                                                    |
| Non-Universal   | Universal     | Any                              | UMIO will be operational but its license will be marked as invalid or rejected. The system will not be able to enable services due to no license. |



| Chassis       | MIO/UMIO                          | DPC/UDPC or DPC2/UDPC2     | System Behavior                                                                                                                                                                  |
|---------------|-----------------------------------|----------------------------|----------------------------------------------------------------------------------------------------------------------------------------------------------------------------------|
| Non-Universal | Active UMIO, Standby MIO or empty | Any                        | Both Active MIO and Standby UMIO will be operational but their licenses will be marked as invalid or rejected. The system will not be able to enable services due to no license. |
| Non-Universal | Active MIO, Standby UMIO          | Non-Universal, Mix or None | UDPC/UDPC2s will be shut down. The MIO and UMIO will run.                                                                                                                        |

**Table 26: License Support Matrix for StarOS Version without Universal Card Support**

| Chassis | MIO/UMIO                 | DPC/UDPC or DPC2/UDPC2 | System Behavior                                                                                                   |
|---------|--------------------------|------------------------|-------------------------------------------------------------------------------------------------------------------|
| Any     | Non-Universal            | Non-Universal          | All cards are recognized and run.                                                                                 |
| Any     | Non-Universal            | Universal or Mix       | UDPC/UDPC2s will not boot.                                                                                        |
| Any     | Universal                | Non-Universal or Mix   | UMIO will not boot and remains offline. The system will not be able to enable services due to the lack of an MIO. |
| Any     | Active MIO, Standby UMIO | Any                    | UMIO and UDPC/UDPC2s will not boot and remain offline.                                                            |
| Any     | Active UMIO, Standby MIO | Any                    | UMIO will not boot and the MIO will become Active.                                                                |

## Updating A Chassis License for Universal Cards

This section describes how to update the chassis license.



### Important

Do NOT install the additional UDPC/UDPC2s until the chassis license has been updated as described below.

You do not have to shut down or reboot the ASR 5500 to update the chassis license or install the additional UDPCs. However, if you install the additional UDPC/UDPC2s and they boot under the old chassis license, they will not come into service.

- 
- Step 1** Contact your Cisco account representative and purchase a license update key that supports the number of new UDPC/UDPC2s that will be supported.
  - Step 2** Download the update license key where it can be accessed by CLI commands from the ASR 5500.
  - Step 3** Refer to the *Managing License Keys* section in the *ASR 5500 System Administration Guide*. Follow the instructions for *Installing New License Keys*.
  - Step 4** Install the additional UDPC/UDPC2s in the chassis. Each card should successfully boot. Refer to the *Card Installation* chapter in this guide.
  - Step 5** Run the Exec mode **show card table** command and verify that the additional UDPC/UDPC2s are installed and recognized by StarOS.
  - Step 6** In the Global Configuration mode, run the **card slot\_number mode active** command to make a UDPC/UDPC2 active in the system.
-



# Cable Management System Installation

This appendix describes how to install the ASR 5500 Cable Management System (CMS) and route network cables to ports on the Management Input/Output (MIO/UMIO) cards.



---

**Important** Installation of CMS components is optional.

---

This appendix includes the following sections:

- [Introduction, page 155](#)
- [Installing the Cable Management Tray, page 155](#)
- [Removing Cable Guides, page 159](#)
- [Installing Cable Management Brackets, page 160](#)
- [Routing and Securing Network Cables, page 162](#)
- [CMS Procedure for Replacing ASR 5500 Circuit Cards, page 164](#)

## Introduction

The ASR 5500 cable management system consists of two components. The first is a tray that mounts at the rear of the chassis immediately below the card cage. The second is a cable management bracket that mounts to the faceplate of each MIO/UMIO card.

Network cables are fed from the ends of the tray and are then routed to the MIO/UMIO ports. The cables are secured to the cable management brackets on the MIO/UMIOs via cable ties or hook-and-loop straps, and within the cable management tray via hook-and-loop straps. Placing the tray in the closed (upright) position protects the cables from damage.

## Installing the Cable Management Tray

The cable management tray is packaged in the accessory box that is included in the ASR 5500 chassis shipping container.

**Important**

When installed and closed, the cable management tray adds 4.5 in. (11.4 cm) to the depth of the chassis. When lowered, the tray adds 6.0 in. (15.2 cm) to the depth.

**Important**

Having two installers simplifies the installation process. One installer holds the tray in position while the other secures the swing arms to the sides of the chassis.

To install the tray:

- 
- Step 1** Locate the pre-assembled tray and its mounting hardware (two shoulder screws and two nylon washers).
- Step 2** Position the tray below the rear card cage as shown in the figure below.
- Step 3** Lift a swing arm upward and use it to locate the tapped hole in the side of the chassis to which the swing arm will be attached (see the figure below).
- Step 4** Insert the shoulder screw and nylon washer through the arm and into the tapped hole.
- Step 5** Use the supplied 3/32 in. Allen hex wrench to tighten the shoulder screw. The screw should be tightened to 6 in-lb (0.68 N-m).
- Important** Do not overtighten the shoulder screw or the swing arm will bind.

**Step 6** Repeat Step 3 through Step 5 to secure the other swing arm.

**Figure 32: Installing the Cable Management Tray**

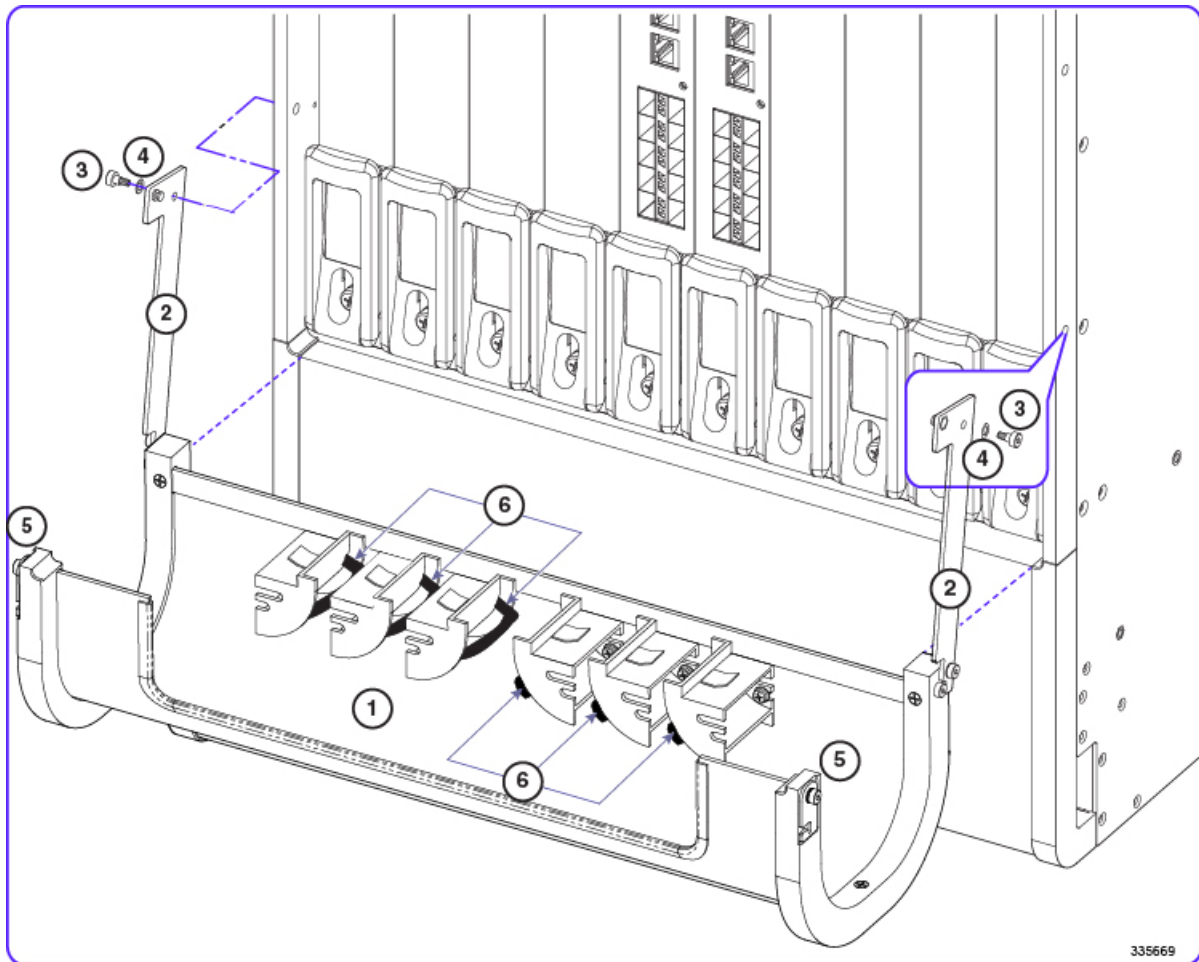

|   |                       |   |                     |
|---|-----------------------|---|---------------------|
| 1 | Cable management tray | 2 | Swing arm           |
| 3 | Shoulder screw        | 4 | Nylon washer        |
| 5 | Latch                 | 5 | Hook-and-loop strap |

**Step 7** Verify that the tray can be swung upward into its closed position. Test the latches by clipping them to the posts on the swing arms. You may need to apply slight inward pressure on the latches so they will clear the swing arms and rest on the posts. See the figure below.

**Figure 33: Testing Latches on the Cable Management Tray**

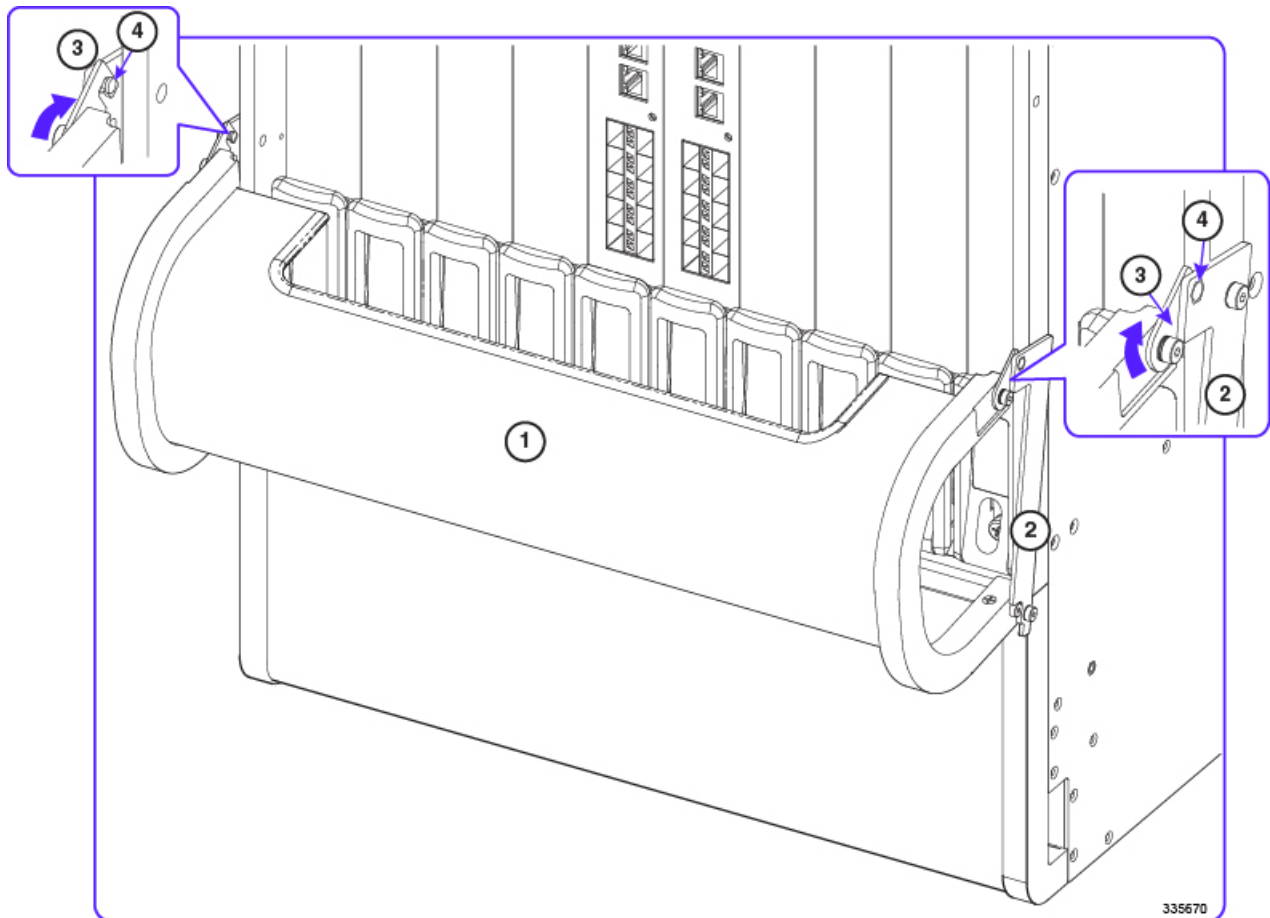

|   |                       |   |           |
|---|-----------------------|---|-----------|
| 1 | Cable management tray | 2 | Swing arm |
| 3 | Latch                 | 4 | Post      |

To lower the cable management tray, unlatch the swing arms and lift the base of the tray slightly upward before allowing it to swing downwards. This completes the installation of the cable management tray. To gain improved access to the hook-and-loop straps on the cable guides, refer to [Removing Cable Guides](#), on page 159. You must install the cable management bracket on each MIO/UMIO card before you can route and secure network cables. For additional information, refer to [Installing Cable Management Brackets](#), on page 160.

## Removing Cable Guides

To gain additional space for accessing the hook-and-loop straps in the cable tray, you may remove the middle cable guides from the left and right side of the tray.

You will need a Phillips #1 screwdriver for this procedure.

To remove a cable guide:

- 
- Step 1** Locate the middle guide in the group of three as shown in the figure below.
  - Step 2** Insert the screwdriver in the top slot of the cable guide.
  - Step 3** Turn the screw that secures the guide to the back of the tray counterclockwise until it drops free of the guide.
  - Step 4** Insert the screwdriver in the bottom slot of the guide.
  - Step 5** Turn the screw that secures the guide to the back of the tray counterclockwise until it drops free of the guide.
  - Step 6** Remove the guide.
  - Step 7** Locate and remove the screws and washers.
  - Step 8** Repeat Step 1 through Step 7 for the middle guide of the other group of three guides.

**Figure 34: Removing Cable Guides**

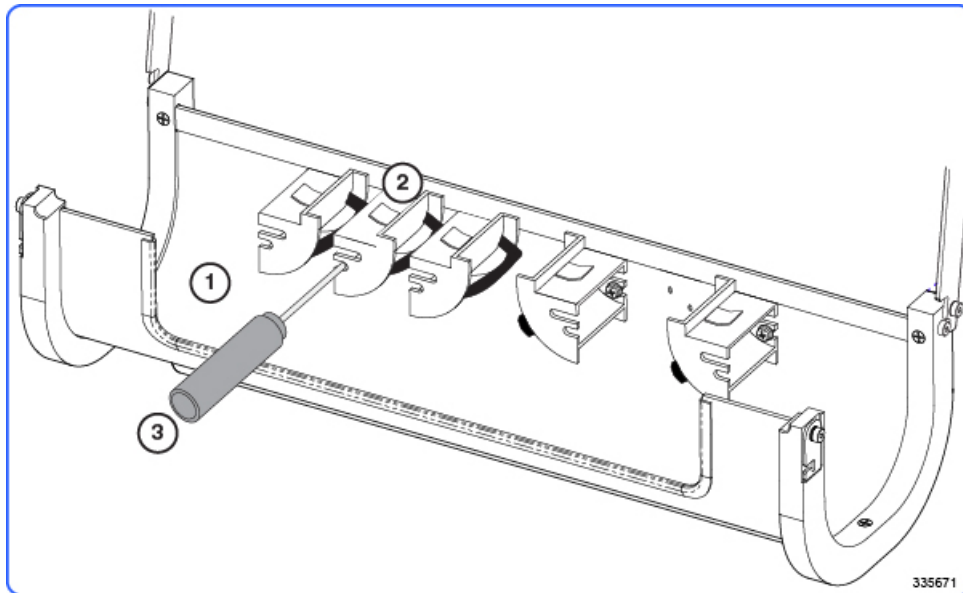

|   |                         |   |             |
|---|-------------------------|---|-------------|
| 1 | Cable management tray   | 2 | Cable guide |
| 3 | Phillips #1 screwdriver |   |             |

## Installing Cable Management Brackets

The cable management bracket is packaged in the MIO/UMIO shipping box.

Ideally, the bracket should be installed on an MIO/UMIO before it is installed in the ASR 5500 chassis. However, you can safely install the bracket on an MIO/UMIO in a powered-up ASR 5500 chassis.

No tools are required to install the bracket on an MIO/UMIO card.

**Caution**

---

Observe ESD precautions when handling the MIO/UMIO. Wear a ground strap connected to the ESD jack located at the upper left corner of the chassis.

---

## MIO/UMIO Cards

To install the bracket on the face of an MIO/UMIO Card:

- 
- Step 1** Locate the bracket and its mounting hardware (two nylon pin-and-sleeve connectors).
  - Step 2** Position the bracket on the faceplate of the MIO/UMIO as shown in the figure below.
  - Step 3** Insert a nylon sleeve in both holes of the bracket and into the MIO/UMIO faceplate.
  - Step 4** Use your thumb to firmly push a nylon pin into each sleeve to secure the bracket to the faceplate.
- Caution** The cable management bracket is not designed to be used as a handle for the MIO/UMIO. Never attempt to lift an MIO/UMIO or remove an MIO/UMIO from the chassis by grasping the bracket.



**Figure 35: Installing Cable Management Bracket - MIO/UMIO Card**

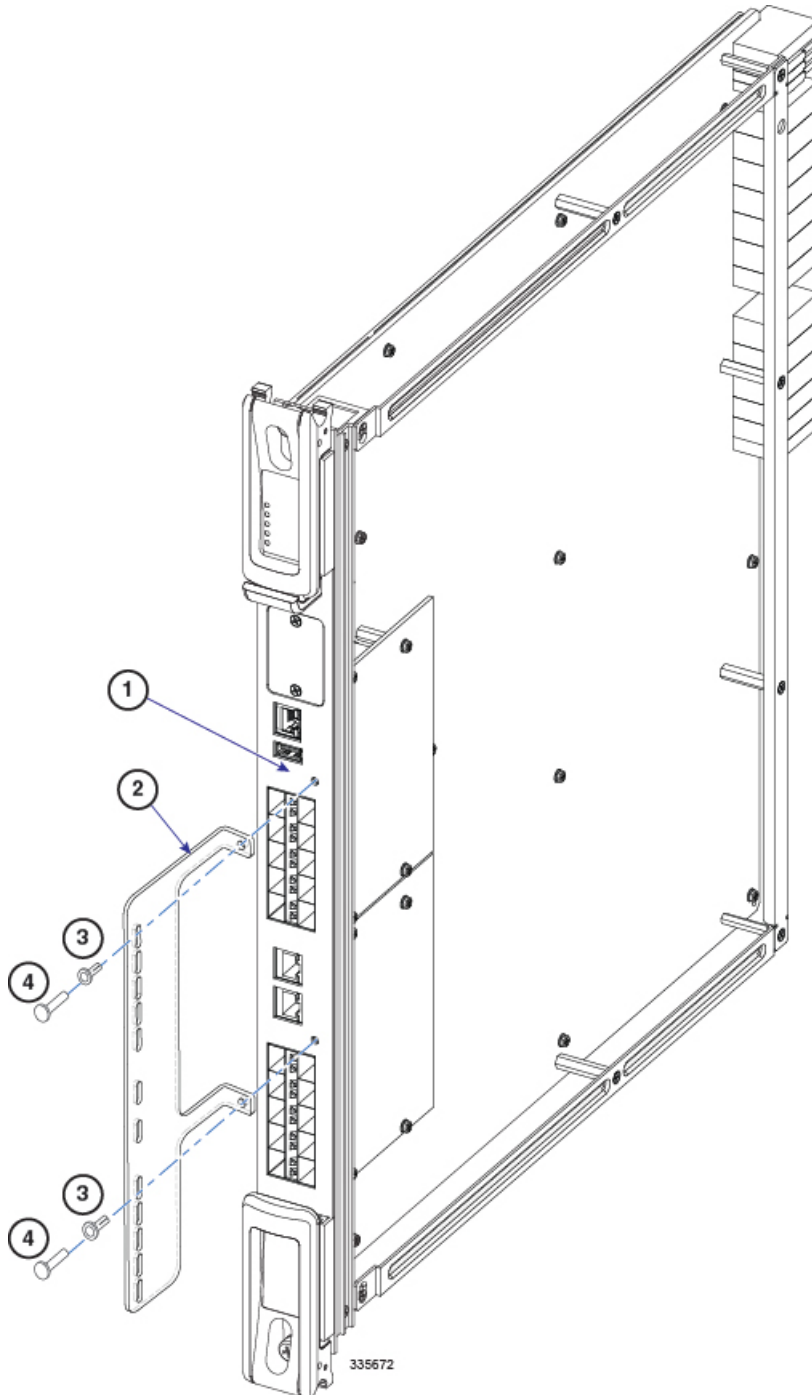

|   |                    |   |                          |
|---|--------------------|---|--------------------------|
| 1 | MIO/UMIO faceplate | 2 | Cable management bracket |
| 3 | Nylon sleeve       | 4 | Nylon pin                |

---

## Securing Cables

This completes the installation of the cable management bracket. You can use cable ties or hook-and-loop straps to secure network cables to the slots in the bracket. For additional information, refer to [Routing and Securing Network Cables](#), on page 162.

## Routing and Securing Network Cables

**Important**

This procedure assumes that the cable management tray has been installed on the ASR 5500 chassis, and cable management brackets have been installed on the MIO/UMIO cards.

The general procedure for using the CMS is to route network cables through either end of the cable management tray upwards toward the cable management brackets on the MIO/UMIOs.

Observe the following guidelines when routing and securing network cables:

- Label each cable with its terminating slot/port number,
- Insert SFP+ transceivers in all 10 GbE ports that will receive cables.
- Use the cable guides on the left side of the tray for cables going to the MIO/UMIO in slot 5, and on the right side of the tray for the MIO/UMIO in slot 6.
- Open the hook-and-loop straps on the cable guides nearest the MIO/UMIOs before routing cables.
- Begin by routing cables that attach at the bottom of the MIO/UMIO and proceed upward from the bottom daughter card (DC) to the top DC.
- Slip the cables beneath the cable guides and loop them upward and within the straps along the curved edges of the guides.
- Keep fiber optic cables going to even number ports to the left of the bracket, odd number ports to the right. Use cable guide A or D for the odd ports, and cable guide B/C or E/F for the even number ports (see the figure below).
- Firmly seat each cable connector into its port.
- Thread nylon cable ties or hook-and-loop straps through the slots in the cable management brackets. Use the ties/straps to secure the cables to the brackets.
- Observe the fiber optic bending radius recommendations found in the *MIO Cabling* chapter.
- Complete the process of securing the cables by closing the hook-and-loop straps on the cable guides. Leave a little slack in the cables to allow the tray to close without pinching the cables.
- For additional support of cable bundles, slip a nylon cable tie or hook-and-loop strap under the clip at the top of a cable guide and wrap it around the bundle.



|   |                          |   |                       |
|---|--------------------------|---|-----------------------|
| 1 | Cable management bracket | 2 | Cable management tray |
| 3 | Cable guides             |   |                       |

**Table 27: CMS Routing Paths**

| Card                | Cable Guide | Notes                   | Destination                |
|---------------------|-------------|-------------------------|----------------------------|
| MIO or UMIO, slot 5 | 3A          | —                       | Bottom DC (ports 20 to 29) |
|                     | 3A          | —                       | 1GbE (ports 1 and 2)       |
|                     | 3B or 3C    | 1                       | Top DC (ports 10 to 19)    |
|                     | 3C          | 2                       | Future                     |
| MIO or UMIO, slot 6 | 3D          | —                       | Bottom DC (ports 20 to 29) |
|                     | 3D          | —                       | 1GbE (ports 1 and 2)       |
|                     | 3E or 3F    | 1                       | Top DC (ports 10 to 19)    |
|                     | 3F          | 2                       | Future                     |
| 3D                  | —           | 1GbE (ports 1 and 2)    |                            |
| 3E or 3F            | 1           | Top DC (ports 10 to 13) |                            |
| 3F                  | 2           | Future                  |                            |
| 3D                  | —           | 1GbE (ports 1 and 2)    |                            |
| 3E or 3F            | 1           | Top DC (ports 10 to 13) |                            |
| 3F                  | 2           | Future                  |                            |

**Notes:**

- 1 If cable guide has been removed.
- 2 Already in use if cable guide has been removed.

## CMS Procedure for Replacing ASR 5500 Circuit Cards

When the cable management tray is installed, the procedure for removing circuit cards from the ASR 5500 chassis varies from that described in the *Circuit Cards* section of the *Replaceable Components* chapter.

## Lowering the Cable Management Tray

---

- Step 1** At the rear of the chassis, apply slight upward pressure at the base of the cable management tray.
- Step 2** Flip the latches on the swing arms upward and free of the posts.
- Step 3** Lower the tray until it rests against the chassis.
- Step 4** If you are removing an MIO/UMIO card, refer to [Detaching Network Cables from the Card Bracket](#), on page 165. Otherwise, remove the circuit card as described in the *Remove and Replace the Circuit Card* section of the *Replaceable Components* chapter.
- Step 5** Proceed to [Raising the Cable Management Tray](#), on page 166.
- 

## Detaching Network Cables from the Card Bracket

---

- Step 1** Cut the nylon cable ties or open the hook-and-loop straps that secure network cables to the MIO/UMIO card.
- Step 2** Unplug the cable connectors starting from the top ports.  
**Important** The ends of all network cables should be labeled with their slot/port terminations. If this has not been done, you should label each cable as you disconnect it.
- Step 3** Move the cable bundles away from the MIO/UMIO. You may have to re-open the hook-and-loop straps in the cable management tray to free the cables.
- Step 4** Remove the MIO/UMIO card as described in *Remove and Replace the Circuit Card* section of the *Replaceable Components* chapter.  
**Caution** Never use the cable management bracket as a "handle" to remove or lift an MIO/UMIO. The bracket is not designed to support the weight of an MIO/UMIO.
- 

## Reconnecting Network Cables to the Card Bracket

---

- Step 1** The replacement MIO/UMIO card should have a cable management bracket pre-installed as described in [Installing Cable Management Brackets](#), on page 160
- Step 2** Route the cables and secure them to the bracket as described in [Routing and Securing Network Cables](#), on page 162
- Step 3** Proceed to [Raising the Cable Management Tray](#), on page 166
-

## Raising the Cable Management Tray

- 
- Step 1** Grasp the base and slowly raise the cable management tray upward.
- Step 2** Verify that the cable tray can be lifted upward and secured without pinching any of the network cables. If necessary increase the slack in a bundle to avoid damaging the cables.
- Step 3** Flip the latches on the swing arms up and over the posts to secure the tray to the chassis.
-



# APPENDIX D

## Console Port to Cisco Server Cabling

This appendix describes how to interconnect the Console port on the Management Input/Output card (MIO/UMIO) to a Cisco communication server or router equipped with an asynchronous interface module. When so equipped these devices can be configured to function as terminal servers in management networks.

This appendix contains the following sections:

- [Introduction, page 167](#)
- [Cabling, page 168](#)
- [Configuration, page 169](#)

### Introduction

Cisco communication servers and routers can be equipped with asynchronous interface modules as shown in the table below. These modules accept one of two types of serial RJ45 "octopus" cables:

- CAB-HD8-ASYNC – uses a single high-density VHDC168M connector at the interface module end,
- CAB-OCTAL-ASYNC – uses a single Micro-D68M connector at the interface module end.

Both cable assemblies source eight 10 ft. (3 meter) cables terminated with male RJ45 plugs.

**Table 28: Cisco Asynchronous Hardware Interface Module Compatibility**

| Async IF Module | 1900 | 2500, 2600 | 2800 | 2900 | 3600, 3700 | 3800 | 3900 | Async RJ45 Adapter Cable |
|-----------------|------|------------|------|------|------------|------|------|--------------------------|
| HWIC-8A/S       | Yes  | —          | —    | Yes  | —          | —    | Yes  | CAB-HD8-ASYNC            |
| HWIC-16A/S      | —    | —          | Yes  | Yes  | —          | Yes  | Yes  |                          |
| NM-16A          | —    | Yes        | —    | —    | Yes        | Yes  | —    | CAB-OCTAL-ASYNC          |
| NM-32A          | —    | Yes        | —    | —    | Yes        | Yes  | —    |                          |

# Cabling

The figure and table below indicate how the MIO/UMIO Console port connects to an interface module via the asynchronous RJ45 adapter cable and a Cisco rollover cable or coupler.

**Figure 37: SR 5500 Console to Cisco CAB Assembly Cabling**

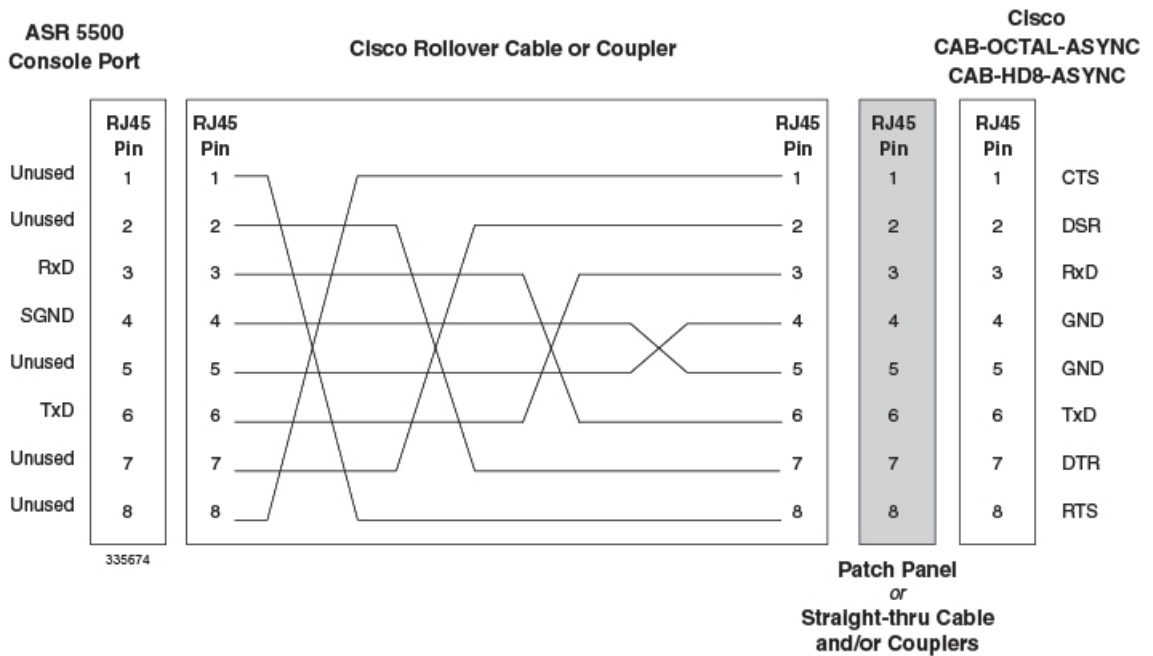

**Table 29: ASR 5500 Console Port to Cisco Terminal Server Pinouts**

| Console Port | RJ45-to-RJ45 Rollover Cable/Coupler |          | CAB-OCTAL-ASYNC CAB-HD8-ASYNC |        |
|--------------|-------------------------------------|----------|-------------------------------|--------|
|              | RJ45 Pin                            | RJ45 Pin | RJ45 Pin                      | Signal |
| Unused       | 1                                   | 8        | 8                             | RTC    |
| Unused       | 2                                   | 7        | 7                             | DTR    |
| RxD          | 3                                   | 6        | 6                             | TxD    |
| SGND         | 4                                   | 5        | 5                             | GND    |
| Unused       | 5                                   | 4        | 4                             | GND    |
| TxD          | 6                                   | 3        | 3                             | RxD    |
| Unused       | 7                                   | 2        | 2                             | DSR    |
| Unused       | 8                                   | 1        | 1                             | CTS    |



## Configuration

The MIO/UMIO facing interface of the Cisco server should be configured via IOS as shown in the following example:

```
line 0/0/0 0/0/14
  exec-timeout 0 0
  no exec
  transport input all
  speed 115200
```

For detailed information, refer to the Configuration guides supplied with the Cisco device and asynchronous interface module. Configuration guides are available at [www.Cisco.com](http://www.Cisco.com).





## APPENDIX **E**

# RMA Shipping Procedures

This appendix describes the procedures for packaging and returning ASR 5500 chassis components via the Cisco Return Material Authorization (RMA) process.

For detailed information on Cisco RMA policies (including detailed shipping instructions), go to the **Product Online Web Returns (POWR)** link on [www.cisco.com](http://www.cisco.com).



### Important

To ensure warranty coverage, these procedures also apply to shipments between customer sites or parts depots.

This appendix includes the following sections:

- [RMA Overview, page 171](#)
- [Packaging ASR 5500 Cards, page 173](#)

## RMA Overview

This section describes general requirements when packaging ASR 5500 components for shipment.



### Important

All components must be properly packaged to prevent damage in transit. Items should never be shipped without packaging foam, bubble wrap and a static bag. Crushed or damaged boxes/pallets should never be used for returning items.

The following general guidelines apply when packaging components:

- It is best to use the original Cisco box and packaging in which your equipment was sent and received. You can use a shipping carton saved when the system and its components were installed. You can also use the packaging for a replacement component to repackage the original component.
- If the original box is missing or damaged, you can request that Cisco send a suitable shipping carton when requesting an RMA.
- Items should be securely sealed and, if necessary, fixed onto pallets.
- Detailed ship-to instructions will be provided when you apply for the RMA from Cisco.

## Re-packaging Your RMA

If using the original Cisco box and packaging, properly place the item within the packaging material.

If using a non-Cisco shipping carton and packing material, be sure the item is properly surrounded with bubble wrap or packaging foam to ensure restriction in movement during transport.

**Caution**

---

The use of anti-static packaging materials is highly recommended. At the very least, the item must be enclosed in a sealed anti-static envelope or bag to prevent damage to ESD sensitive devices.

---

## Shipping Multiple Components

The preferred method for RMA shipping requires that each component be properly packed in an individual box.

If you must ship multiple items within the same box, be sure each part is protected in its own anti-static bag and padded carton, and is separated from other cartons with packing foam or bubble wrap. The shipping carton must be sturdy enough to handle the weight and size of the items within it.

**Important**

---

Items should never be returned loosely packed and unprotected from ESD.

---

## Sealing the Shipment

The box or shipping container must be securely sealed using appropriately reinforced packaging tape. Do not use masking or transparent (light duty) tape to secure or seal packaging.

Chassis or other large units must be covered and securely strapped down to a pallet. An unstrapped or loosely strapped item can easily tip during transit, resulting in expensive damage and repair costs.

## Labeling the Shipment

All returned items must include the RMA number (and Quote Number for Trade-In Returns) on every box being returned.

For Trade-In Returns, a POWR tool label must be placed on the outside of each box.

These reference numbers should also be listed on the shipper's air bill.

**Important**

---

Mislabelled or unlabeled RMAs delay the receiving and crediting processes.

---

## Cisco Return Locations

For a list of authorized Cisco return centers, go to the **Authorized Return Locations** link on [www.cisco.com](http://www.cisco.com).

## Packaging ASR 5500 Cards

This section provides detailed instructions for packaging ASR 5500 front and rear cards using Cisco shipping cartons.

### Front Cards

The packing instructions in this section apply to the following cards:

- Fabric and Storage Card (FSC)
- System Status Card (SSC)



---

**Important**

Front cards use the smaller ESD bags and shipping cartons.

---

The packaging sequence is as follows:

- 
- Step 1** Place the card inside the ESD bag; fold over and seal the bag with an ESD Label or invisible tape as shown in the figure below.
  - Step 2** Place the card in the carton as shown in the figure below.
  - Step 3** Place the top piece of foam over the card.
  - Step 4** Close the carton and seal it with shipping tape. See [Sealing the Shipment, on page 172](#).
  - Step 5** Place the shipping label on the outside of the carton. See [Labeling the Shipment, on page 172](#).

**Figure 38: Front Card Packaging**



335675

## Rear Cards

The packing instructions in this section apply to the following cards:

- Management Input/Output (MIO) or Management Input/Output Universal (UMIO) card
- Data Processing Card (DPC) or Data Processing Universal (UDPC)
- Data Processing Card v2 (DPC2) or Data Processing Universal v2 (UDPC2)



### Important

Rear cards use the larger ESD bags and shipping cartons. There are very slight differences in the cutouts at the rear of the MIO/UMIO, DPC/DPC2 or UDPC/UDPC2 foam.



**Important** MIO/UMIO cards must be returned with all SFP+ transceivers installed. Replacement MIO/UMIO cards are shipped with new SFP+ transceivers installed.

The packaging sequence is as follows:

**Step 1** Place the card inside the ESD bag; fold over and seal the bag with an ESD Label as shown in the figure below.

**Figure 39: Rear Card Packaging**



335676

**Step 2** Place the card in the carton as shown in the figure below.

**Step 3** Place the top piece of foam over the card.

**Step 4** Close the carton and seal it with shipping tape. See [Sealing the Shipment](#), on page 172.

**Step 5** Place the shipping label on the outside of the carton. See [Labeling the Shipment](#), on page 172.

