



Cisco Flex 7500 Series Wireless Controller Installation Guide

About this Guide

This guide is designed to help you install and minimally configure your Cisco Flex 7500 Series Wireless Controller.

- [Cisco Flex 7500 Series Wireless Controller, page 1-2](#)
- [What is in the Cisco Flex 7500 Series Wireless Controller, page 1-3](#)
- [Compliance and Safety Information, page 1-5](#)
- [General Warnings, Regulatory and Safety, page 1-5](#)
- [Required Tools and Information, page 1-6](#)
- [Choosing a Physical Location for the Cisco Flex 7500 Series Wireless Controller, page 1-8](#)
- [Unpacking the Controller, page 1-11](#)
- [Mounting the Cisco Flex 7500 Series Wireless Controller in a Rack, page 1-12](#)
- [Front Panel, page 1-19](#)
- [Rear Panel, page 1-24](#)
- [Grounding the Chassis, page 1-29](#)
- [Preventing ESD Damage, page 1-30](#)
- [Replacing a Failed Hot-Swap Hard Disk Drive, page 1-30](#)
- [Replacing a Hot-Swap AC Power Supply, page 1-31](#)
- [Connecting the Cables, page 1-32](#)
- [Connecting and Using the CLI Console, page 1-33](#)
- [Powering On the Controller, page 1-33](#)
- [Using the Startup Wizard, page 1-36](#)
- [Controller Specifications, page 1-42](#)
- [Obtaining Documentation and Submitting a Service Request, page 1-42](#)
- [Cisco 90-Day Limited Hardware Warranty Terms, page 1-42](#)

After installation and power up is complete, refer to the following documents for additional information on the Cisco Flex 7500 Series Wireless Controller:

- For detailed software configuration information, refer to the appropriate controller configuration guide.
- For detailed feature support and compatibility information, refer to the latest release notes for the Cisco Flex 7500 Series Wireless Controller.

These documents are available on Cisco.com. Follow these steps to access these documents:

-
- Step 1** Browse to <http://www.cisco.com>.
 - Step 2** Click **Support**. A new window appears.
 - Step 3** Click **Wireless** under Find Product Support. The Select Your Product or Technology page appears.
 - Step 4** Enter **Cisco Flex 7500** in the Find field and click **Find**.
 - Step 5** Click the **Cisco Flex 7500 Series Wireless Controllers** link. The Cisco Flex 7500 Series Controllers Introduction page appears.
 - Step 6** Choose the appropriate link for the documentation you want to view or download.
-

Cisco Flex 7500 Series Wireless Controller

The Cisco Flex 7500 Series Wireless Controller is a highly scalable branch controller for multi-site wireless deployments in which the controller is consolidated in the data center.

The Cisco Flex 7500 Series Wireless Controller can manage wireless access points in up to 500 branch locations and allows IT managers to configure, manage, and troubleshoot up to 2,000 access points and 20,000 clients from the data center. The Cisco Flex 7500 Series Wireless Controller supports secure guest access, rogue detection for Payment Card Industry (PCI) compliance and in-branch (locally switched) Wi-Fi voice and video.

This Installation Guide contains information and instructions for setting up your Cisco Flex 7500 Series Wireless Controller and instructions for cabling and configuring the controller. For diagnostics and troubleshooting information, see diagnostics and troubleshooting tables, [Table 1-1 on page 1-23](#) and [Table 1-2 on page 1-28](#).

Figure 1-1 Cisco Flex 7500 Series Wireless Controller

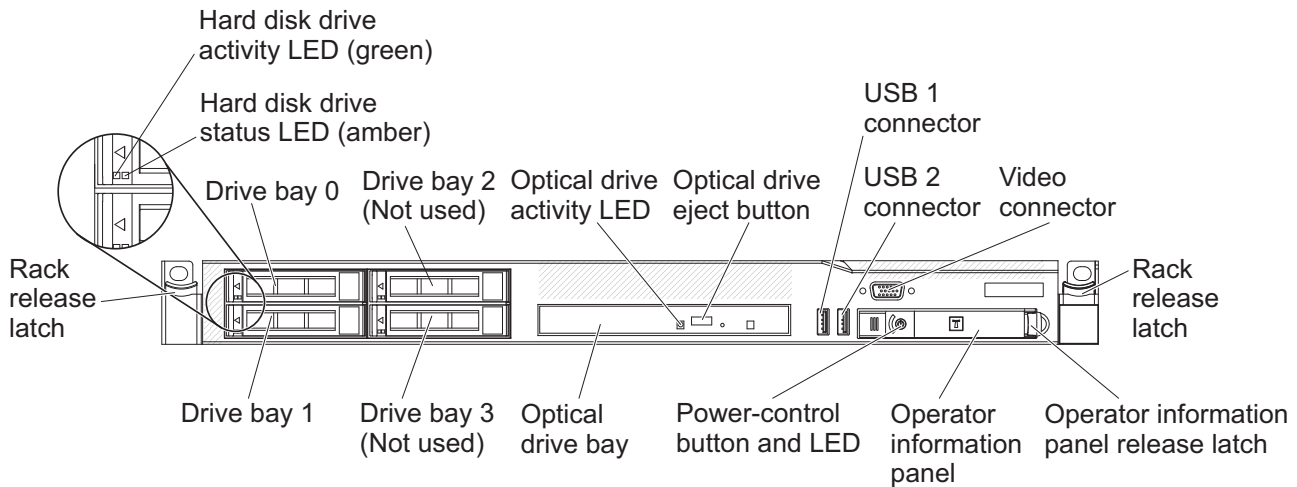

282299

**Note**

The power supply, fan, and temperature status are periodically polled from the Cisco WLC software in the intervals of 600 seconds (10 minutes). Therefore, any change in the status of power supply, fan, or temperature can take up to 600 seconds to be reflected.

What is in the Cisco Flex 7500 Series Wireless Controller

The following sections describe the features and technologies used by the Cisco Flex 7500 Series Wireless Controller.

Integrated Management Module

One of the features of Cisco Flex 7500 Series Wireless Controller is Integrated Management Module (IMM). The IMM combines service processor functions.

The IMM controls the service-processor, monitors, and alerts. If an environmental condition exceeds threshold or if a system component fails, the IMM turns LEDs on to help you diagnose the problem, alert you, and record the error in the event log.

The IMM provides remote server management through these industry-standard interfaces:

- Simple Network Management Protocol (SNMP) version 3
- Web Browser

For additional information, see the *Integrated Management Module User Guide*.

Light path diagnostics

Light path diagnostics provides LEDs to help you diagnose problems. For more information about the light path diagnostics, see [Light Path Diagnostics Panel, page 1-21](#).

Compliance and Safety Information

FCC Safety Compliance Statement

Modifying the equipment without Cisco's authorization may result in the equipment no longer complying with FCC requirements for Class A digital devices. In that event, your right to use the equipment may be limited by FCC regulations, and you may be required to correct any interference to radio or television communications at your own expense.

This equipment has been tested and found to comply with the limits for a Class A digital device, pursuant to Part 15 of the FCC Rules. These limits are designed to provide reasonable protection against harmful interference when the equipment is operated in a commercial environment. This equipment generates, uses, and can radiate radio frequency energy and, if not installed and used in accordance with the instruction manual, may cause harmful interference to radio communications. Operation of this equipment in a residential area is likely to cause harmful interference in which case users will be required to correct the interference at their own expense.

Try to correct the interference by one or more of the following measures:

- Verify that the ambient temperature remains between 50 to 95° F (10 to 35° C), taking into account the elevated temperatures when installed in a rack or enclosed space.
- When multiple Cisco Flex 7500 Series Wireless Controllers are mounted in an equipment rack, be sure that the power source is sufficiently rated to safely run all the equipment in the rack.
- Verify the integrity of the electrical ground before installing the controller.

General Warnings, Regulatory and Safety

Conventions

Safety warnings appear throughout this guide in procedures that may harm you if performed incorrectly. A warning symbol precedes each warning statement. Specific warnings are included in the sections to which they apply.



This warning symbol means danger. You are in a situation that could cause bodily injury. Before you work on any equipment, be aware of the hazards involved with electrical circuitry and be familiar with standard practices for preventing accidents. Use the statement number provided at the end of each warning to locate its translation in the translated safety warnings that accompanied this device. Statement 1071 SAVE THESE INSTRUCTIONS



Means reader be careful. In this situation, you might do something that could result in equipment damage or loss of data.

Warnings

The warnings below are general warnings that are applicable to the entire guide. Specific warnings are included in the sections to which they apply.



Warning

There is the danger of explosion if the battery is replaced incorrectly. Replace the battery only with the same or equivalent type recommended by the manufacturer. Dispose of used batteries according to the manufacturer's instructions. Statement 1015



Warning

Read the installation instructions before connecting the system to the power source. Statement 1004



Warning

Only trained and qualified personnel should be allowed to install, replace, or service this equipment. Statement 1030



Warning

Ultimate disposal of this product should be handled according to all national laws and regulations. Statement 1040



Warning

Class 1 laser product. Statement 1008

Required Tools and Information

This section lists the required hardware and other information that you need to install and setup the controller.

Required Hardware

You need this equipment to install a Cisco Flex 7500 Series Wireless Controller in an Electronics Industries Alliance (EIA) rack:

- A Cisco Flex 7500 Series Wireless Controller
- Network cables
- One rack unit (RU) free space in an EIA-standard rack
- One or two Cisco SFP-10G-SR modules and corresponding optical cables
- Rack mounting kit (included with the Cisco Flex 7500 Series Wireless Controller shipment)
- A serial console cable



Note

If you are installing this unit in a threaded-hole rack, you must supply screws that fit the threaded-hole rack and the appropriate screwdriver or Torx driver for those screws.

CLI Console Requirements

You need this equipment to connect to the controller console:

- ANSI or VT-100 terminal emulator application on a laptop, desktop, or palmtop

System Configuration Parameters

Obtain the following initial configuration parameters from your wireless LAN or network administrator:

- A system (controller) name.
- An administrative username and password.
- A service port interface IP address configuration protocol (none or DHCP).
- A management interface (DS port or network interface port) IP address.



Note The service port interface and management interface must be on different subnets.

- A management interface netmask address.
- A management interface default router IP address.
- A VLAN identifier if the management interface is assigned to a VLAN, or 0 for an untagged VLAN.
- Distribution system physical port number—1 through 2 for back panel 10 Gigabit Ethernet ports (with SFP+ 10G module).
- IP address of the default DHCP server that will supply IP addresses to clients.
- A virtual gateway IP address (a fictitious, unassigned IP address, such as 192.0.2.1, used by all Cisco wireless LAN controller Layer 3 security and mobility managers).
- A Cisco wireless LAN controller mobility group name, if required.
- An 802.11 network name (SSID) for WLAN 1. This is the default SSID that the access points use when they join with the controller.
- Whether or not to allow static IP addresses from clients.
 - Yes is more convenient, but has lower security (session can be hijacked).
 - No is less convenient, but has higher security and works well for Windows XP devices.
- RADIUS server IP address, communications port, and secret (if you are configuring a RADIUS server).
- The country code for this installation. Refer to the *Cisco Wireless LAN Controller Configuration Guide* for country code information. This guide is available at cisco.com.
- Status of the 802.11a, 802.11b, and 802.11g networks (enabled or disabled).
- Status of radio resource management (RRM) (enabled or disabled).
- An IP address for the Integrated Management Module (IMM), if you are using a static IP address for IMM access. The IMM can use either a shared port with service port or the dedicated IMM Ethernet port.

Choosing a Physical Location for the Cisco Flex 7500 Series Wireless Controller

For maximum safety and reliability, mount the controller using the following guidelines.

General Precautions

To reduce the risk of personal injury or damage to the controller:

- Place the product away from radiators, heat registers, stoves, amplifiers, or other products that produce heat.
- Never use the product in a wet location.
- Avoid inserting foreign objects through openings in the product.
- To reduce risk of injury from electric shock hazards, do not open the product enclosure.

Laser Devices

Laser devices are used within the DVD of the controller. The DVD has no defined use at the customer site.

To reduce the risk of exposure to hazardous radiation:

- Do not try to open the laser device enclosure. There are no user-serviceable components inside.
- Do not operate controls, make adjustments, or perform procedures to the laser device other than those specified herein.
- Allow only Cisco authorized service technicians to repair the laser device.

Space and Airflow Requirements

Install the controller in a EIA-standard rack. One rack unit is required for each controller.

Ensure that you can reach the controller and all cables.

- Ensure that the controller is within 328 ft (100 m) equivalent distance from any equipment connected to the 10/100/1000BASE-T/10G ports. For specifications on the fiber optic cables, see [“Connecting the Network \(Distribution System\)” section on page 1-41](#).
- Ensure that the power cord can reach a 110 or 220 VAC grounded electrical outlet.

Ensure that there is sufficient room at the back of the controller for all cables and connectors.

- Leave a minimum clearance of 63.5 cm (25 in.) in front of the rack.
- Leave a minimum clearance of 76.2 cm (30 in.) behind the rack.
- Leave a minimum clearance of 121.9 cm (48 in.) from the back of the rack to the back of another rack or row of racks.

**Caution**

To prevent improper cooling and damage to the equipment, do not block the ventilation openings.

**Caution**

Always use blanking panels to fill empty vertical spaces in the rack. This arrangement ensures proper airflow. Using a rack without blanking panels results in improper cooling that can lead to thermal damage.

**Caution**

When selecting a rack to use, observe the following additional requirements to ensure adequate airflow and to prevent damage to the equipment: (1) Front and rear doors—If the 42U rack includes closing front and rear doors, you must allow 5,350 sq. cm (830 sq. in.) of holes evenly distributed from top to bottom to permit adequate airflow (equivalent to the required 64 percent open area for ventilation). (2) Side—The clearance between the installed rack component and the side panels of the rack must be a minimum of 7 cm (2.75 in.).

Temperature Requirements

To ensure continued safe and reliable equipment operation, install or position the system in a well ventilated, climate-controlled environment.

Ensure that the ambient operating temperature remains between 10 and 35° C (50 and 95° F), taking into account the elevated temperatures that occur when equipment is installed in a rack. The equipment could operate at the extended temperature between 5 and 40° C (41 and 104° F) if needed.

**Caution**

To reduce the risk of damage to the equipment when installing third-party options: (1) Do not permit optional equipment to impede airflow around the controller or to increase the internal rack temperature beyond the maximum allowable limits. (2) Do not exceed the manufacturer's maximum recommended ambient temperature (TMRA).

Power Requirements

Installation of this equipment must comply with local and regional electrical regulations governing the installation of information technology equipment by licensed electricians. This equipment is designed to operate in installations covered by NFPA 70, 1999 Edition (National Electric Code) and NFPA 75, 1992 (code for Protection of Electronic Computer/Data Processing Equipment). For electrical power ratings on options, refer to the product rating label or the user documentation supplied with that option.

**Caution**

Protect the controller from power fluctuations and temporary interruptions with a regulating uninterruptible power supply (UPS). This device protects the hardware from damage caused by power surges and voltage spikes and keeps the system in operation during a power failure.

When installing more than one controller, you may need to use additional power distribution devices (PDUs) to safely provide power to all devices. Observe the following guidelines:

- Balance the controller power load among available AC supply branch circuits.
- Do not allow the overall system AC current load to exceed 80 percent of the branch circuit AC current rating.
- Do not use common power outlet strips for this equipment.

- Provide a separate electrical circuit for the controller.

Power Supplies on the Cisco Flex 7500 Series Wireless Controller

The Cisco Flex 7500 Series Wireless Controller has two power supplies.



Warning

This unit might have more than one power supply connection. All connections must be removed to de-energize the unit. Statement 1028



Caution

Verify that the external power source connected to the controller matches the type of power source indicated on the electrical ratings label. If you are not sure of the type of power source required, consult your Cisco authorized reseller or local power company.

Batteries

The controller might include a real-time clock battery or coin cell battery that might contain perchlorate and might require special handling when recycled or disposed of in California.

Refer to the following link for disposal information.

<http://www.dtsc.ca.gov/hazardouswaste/perchlorate>



Caution

Do not dispose of batteries with the general household waste. Recycle them using the public collection system.

Electrical Grounding Requirements

The controller must be grounded properly for proper operation and safety. In the United States, you must install the equipment in accordance with NFPA 70, 1999 Edition (National Electric Code), Article 250, as well as any local and regional building codes. In Canada, you must install the equipment in accordance with Canadian Standards Association, CSA C22.1, Canadian Electrical Code. In all other countries, you must install the equipment in accordance with any regional or national electrical wiring codes, such as the International Electrotechnical Commission (IEC) Code 364, parts 1 through 7.

Furthermore, you must verify that all power distribution devices used in the installation, such as branch wiring and receptacles, are listed or certified grounding-type devices. Because of the high ground-leakage currents associated with multiple systems connected to the same power source, Cisco recommends the use of a PDU that is either permanently wired to the building's branch circuit or includes a nondetachable cord that is wired to an industrial-style plug. NEMA locking-style plugs or those complying with IEC 60309 are considered suitable for this purpose. Using common power outlet strips for the controller is not recommended.

Rack Warnings



To prevent bodily injury when mounting or servicing this unit in a rack, you must take special precautions to ensure that the system remains stable. The following guidelines are provided to ensure your safety: (1) This unit should be mounted at the bottom of the rack if it is the only unit in the rack. (2) When mounting this unit in a partially filled rack, load the rack from the bottom to the top with the heaviest component at the bottom of the rack. (3) If the rack is provided with stabilizing devices, install the stabilizers before mounting or servicing the unit in the rack. Statement 1006.



To reduce the risk of personal injury or equipment damage when unloading a rack, at least two people are needed to safely unload the rack from the pallet.



To prevent damage, ensure that water or excessive moisture cannot get into the controller.

Unpacking the Controller

Follow these steps to unpack the Cisco Flex 7500 Series Wireless Controller and prepare it for operation:

- Step 1** Open the shipping container and carefully remove the contents.
- Step 2** Return all packing materials to the shipping container and save it.
- Step 3** Ensure that all items listed in the “[Package Contents](#)” section on page 1-11 are included in the shipment.
- Step 4** Check each item for damage. If any item is damaged or missing, notify your authorized Cisco sales representative.

Package Contents

Each access point package contains the following items:

- Cisco Flex 7500 Series Wireless Controller
- One rack mount kit
- Two power cords
- One console cable for 10 Gb SFP+ card
- *Regulatory Compliance and Safety Information for the Cisco Flex 7500 Series Wireless Controller*
- Cisco product registration and Cisco documentation feedback cards

Mounting the Cisco Flex 7500 Series Wireless Controller in a Rack

**Warning**

Only trained and qualified personnel should be allowed to install, replace, or service this equipment. Statement 1030

**Caution**

The controller is heavy (35 lbs, 15.9 kgs).

To reduce the risk of personal injury or damage to the equipment:

- Observe local occupational health and safety requirements and guidelines for manual material handling.
- Get help to lift and stabilize the controller during installation or removal is recommended, especially when the system is not fastened to the rails.
- Use caution when installing the controller in or removing it from the rack; it is unstable when not fastened to the rails.
- Always plan the rack installation so that the heaviest item is on the bottom of the rack. Install the heaviest item first and continue to populate the rack from the bottom to the top.

The controller comes with a universal rack mount kit that can be installed in a square-hole rack, round-hole rack, or a threaded-hole rack. You can order replacement universal rack mount kits from Cisco. The replacement part PID is AIR-SRVR-URMK=.

**Note**

You must provide the threaded-hole screws to secure the mounting rails to the rack. Threaded-hole screws are not shipped with the system.

Installing the Controller Into the Rack Cabinet Using Universal Rack Mount Kit

Review the documentation that comes with the rack cabinet for safety and cabling information. Before you install the controller in a rack cabinet, review the following guidelines:

- Two or more people are required to install this device in a rack cabinet.
- Make sure that the room air temperature is below 35° C (95° F).
- Do not block any air vents; usually 15 cm (6 in.) of space provides proper airflow.
- Do not leave open spaces above or below an installed controller in your rack cabinet. To help prevent damage to controller components, always install a blank filler panel to cover the open space and to help ensure proper air circulation.
- Install the controller only in a rack cabinet with perforated doors.
- Plan the device installation starting from the bottom of the rack cabinet.
- Install the heaviest device in the bottom of the rack cabinet.
- Do not extend more than one device out of the rack cabinet at the same time.
- Remove the rack doors and side panels to provide easier access during installation.
- Connect the controller to a properly grounded outlet.

- Do not overload the power outlet when you install multiple devices in the rack cabinet.
- Install the controller in a rack that meets the following requirement:
 - Minimum depth of 70 mm (2.76 in.) between the front mounting flange and inside of the front door.

**Caution**

Use safe practices when lifting.



≥ 18 kg (39.7 lb.)



≥ 32 kg (70.5 lb.)



≥ 55 kg (121.2 lb.)

**Caution**

Do not place any object on top of rack-mounted devices.



The following illustration shows the items that you need to install the controller in the rack cabinet. If any items are missing or damaged, contact your place of purchase.

**Note**

Some items come with the controller, not in the rack installation kit.

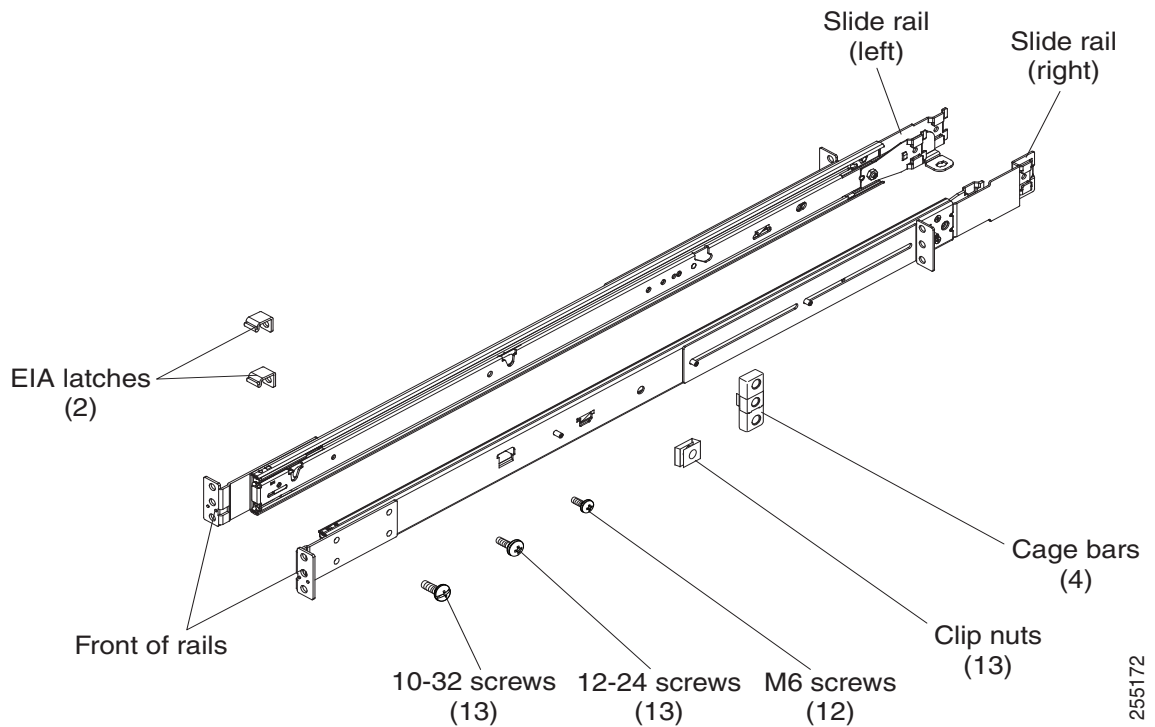
**Note**

Use cage bars with square-holed racks, clip nuts with round-holed racks, and your own screws or the screws provided in this kit with threaded-hole racks.

**Note**

If the slide rails in your rack installation kit came with shipping thumbscrews, remove them before you begin the following installation procedure.

Step 1

Select an available 1 U space in your rack to install your controller. If you have either a round-holed or square-holed rack, install cage bars or clip nuts in the middle and the bottom (optional for the upper) holes of the lower U on each side of the front of the rack. Then, install cage bars or clip nuts in the upper and the bottom holes of the lower U on each side of the rear of the rack.

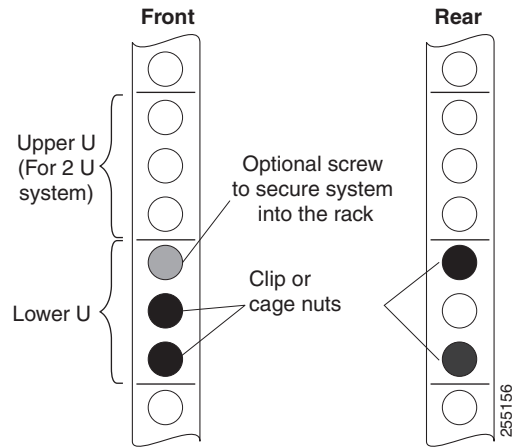

- Step 2** Use a screwdriver to install the cage bars or the clip nuts on the inside of the mounting rail, as required for your rack, into the selected holes.

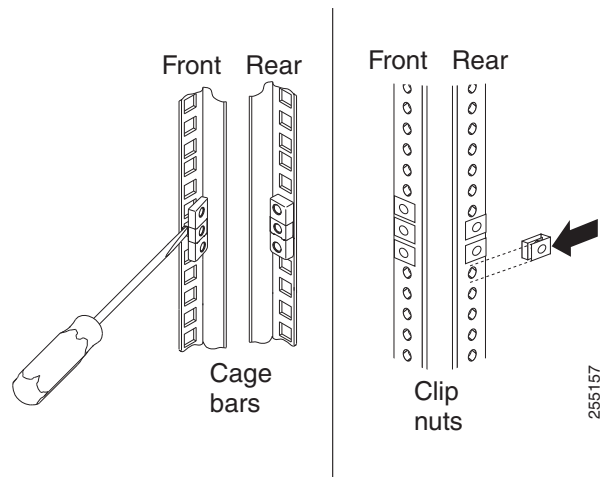

- Step 3** The rail depth can be adjusted from 17 in (432 mm) to 31.25 in (794 mm). To adjust the depth, you can loosen the nuts on the posts and slide the bracket until the distance between the front and rear slide rail flanges matches the distance between the front and rear EIA rails of the rack cabinet. If you need further adjustment, remove the nuts, move the bracket to the appropriate set of posts (A, B, C, and D) to obtain the appropriate slide rail depth, then reinstall and tighten the nuts.

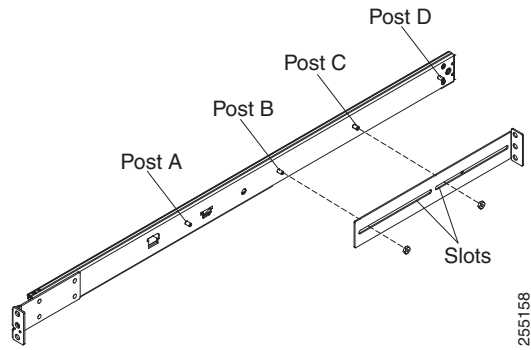

- Step 4** To remove the support bracket, remove the screw (1) and remove the bracket (2) from the rear of the slide rail.

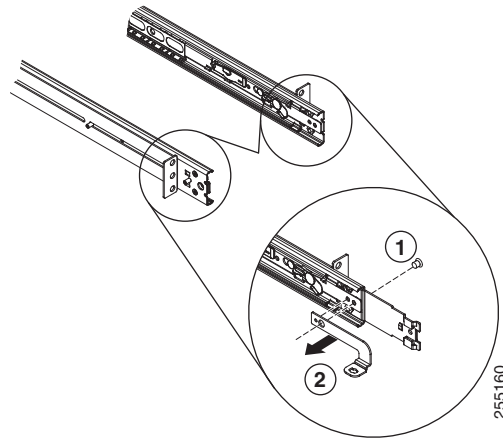

- Step 5** To remove the mounting brackets, remove the screws (1) and (3). Slide out the brackets (2) and (4) from the rear of the slide rail.

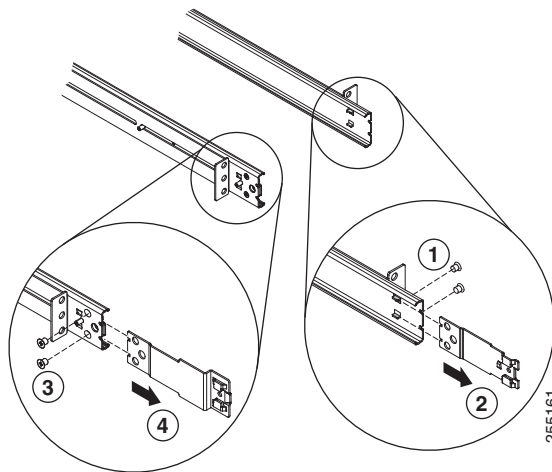

- Step 6** Attach the front of the slide rail and EIA latch to the front of the rack cabinet by installing a screw in the bottom hole of the lower U; then, install another screw in the middle hole of the lower U to attach the front of the slide rail to the front of the rack cabinet.



Note When you fasten the slides to the rack, ensure the screws are engaged but the flange can move slightly. You will use a screwdriver to fully tighten them in [Step 9](#).



Note Use 12-24 screws (not hex head M6 screws) on the front mounting bracket if you are installing this system into a rack with round or square holes (i.e., not threaded holes).

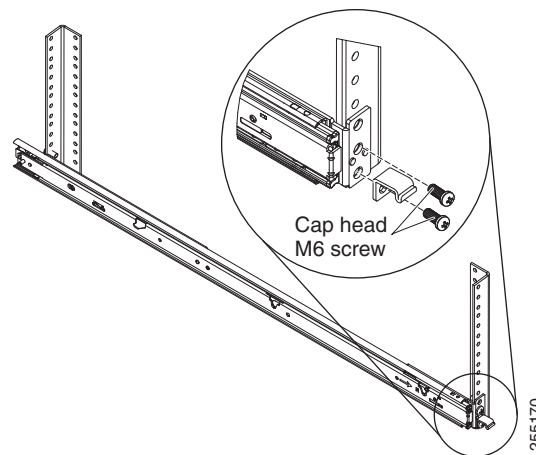

- Step 7** Use two screws to attach the rear of the slide rail to the rear of the rack cabinet in the upper and the bottom holes of the lower U.

Repeat [Step 3](#) through [Step 7](#) to install the other slide rail into the rack.

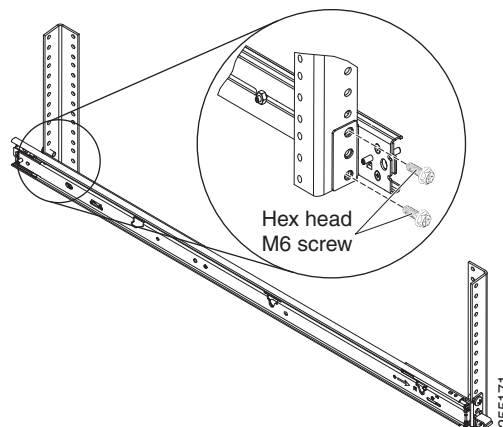

- Step 8** Pull the slide rails forward (1) until they click, two times, into place. Carefully lift the controller and tilt it into position over the slide rails so that the rear nail heads (2) on the controller line up with the rear slots (3) on the slide rails. Slide the controller down until the rear nail heads slip into the two rear slots, and then slowly lower the front of the controller (4) until the other nail heads slip into the other slots on the slide rails. Make sure that the front latch (5) slides over the nail heads.

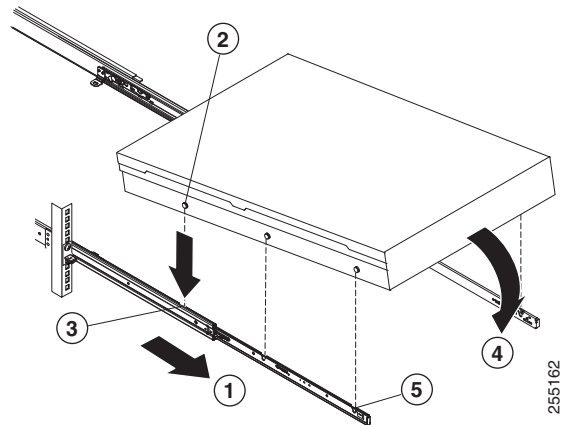

- Step 9** Lift the locking levers (1) on the slide rails and push the controller (2) all the way into the rack until it clicks into place.

Slide the system in and out twice to make sure the system slides correctly. Push the system inwards to the rack as close as possible but able to access the screws with a screwdriver. Then tighten the screws with a screwdriver.

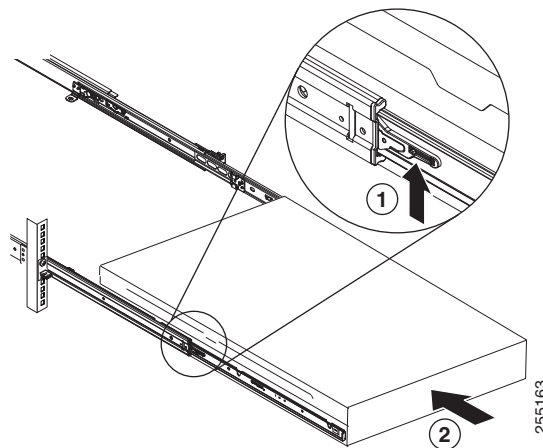

- Step 10** Slide the controller into the rack until it snaps into place. To slide the controller out of the rack, press on the release latches (1).

**Note**

When you move the rack cabinet, or if you install the rack cabinet in a vibration-prone area, insert the optional M6 screws (2) in the front of the controller.

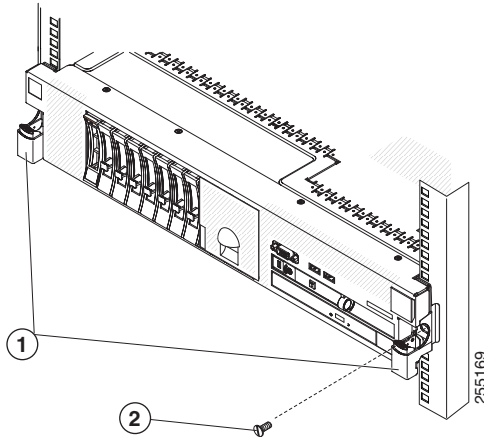

To remove the controller from the rack, reverse these instructions. Store this information with your controller documentation for future use.

Front Panel

Figure 1-2 shows the controls, Light Emitting Diodes (LEDs), and connectors on the front panel of the Cisco Flex 7500 Series Wireless Controller.

Figure 1-3 shows a detailed view of the operator information panel.

Figure 1-2 Cisco Flex 7500 Series Wireless Controller Front Panel

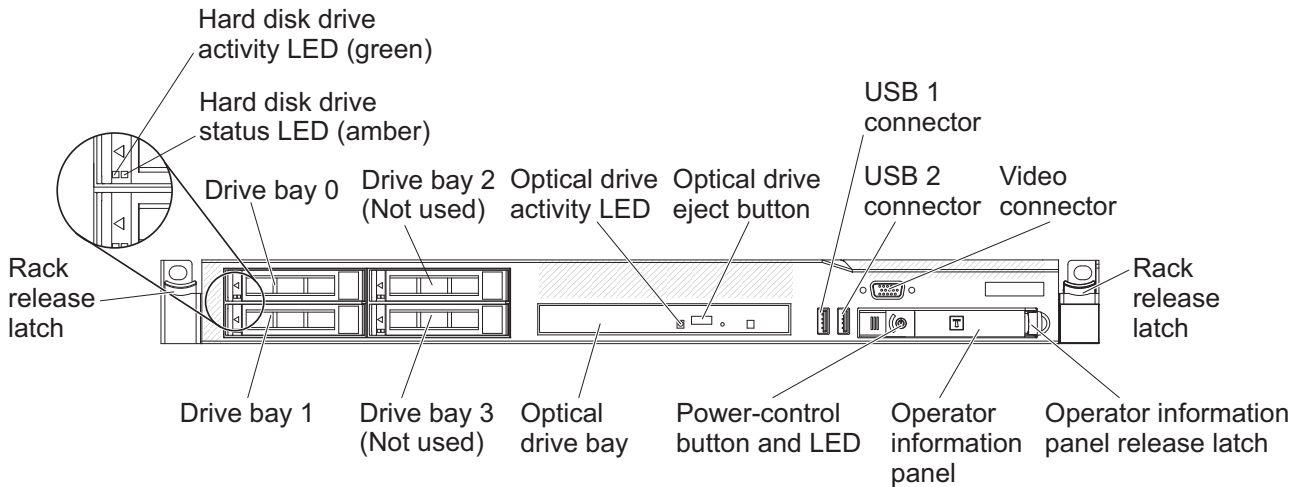

282299

Front Panel Components

- **Rack release latches:** Press the latches on each front side of the controller to remove it from the rack.

- **Hard disk drive status LEDs:** This LED is used to indicate the status of the SAS hard disk drives. When this LED is lit, it indicates that the drive has failed. When this LED is flashing slowly (one flash per second), it indicates that the drive is being rebuilt. When the LED is flashing rapidly (three flashes per second), it indicates that the controller is identifying the drive.
- **Hard disk drive activity LEDs:** Each hot-swap hard disk drive has an activity LED, and when this LED is flashing, it indicates that the drive is in use.
- **Optical drive eject button:** Press this button to release a DVD or CD from the DVD drive.
- **Optical drive activity LED:** When this LED is lit, it indicates that the DVD drive is in use.
- **Operator information panel:** This panel contains controls and LEDs that provide information about the status of the controller. For information about the controls and LEDs on the operator information panel, see [Operator Information Panel, page 1-20](#).
- **Operator information panel release latch:** Slide the blue release latch to the left to pull out the light path diagnostics panel and view the light path diagnostics LEDs and buttons. See [Light Path Diagnostics Panel, page 1-21](#) for more information about the light path diagnostics.
- **Video connector:** Connect a monitor to this connector. The video connectors on the front and rear of the controller can be used simultaneously. Controller configuration and management is only supported via the serial console connection. Controller configuration and management is not supported using the keyboard and monitor directly connected to the controller.



Note The maximum video resolution is 1600 x 1200 at 75 Hz.

- **USB connectors:** Connect a USB device, such as a USB mouse or keyboard, to any of these connectors. During normal operation, this USB slot is not used by the 7500 Series Wireless Controller.

Operator Information Panel

Figure 1-3 shows a detailed view of the controls and LEDs on the operator information panel.

Figure 1-3 Close Up of Cisco Flex 7500 Operator Information Panel

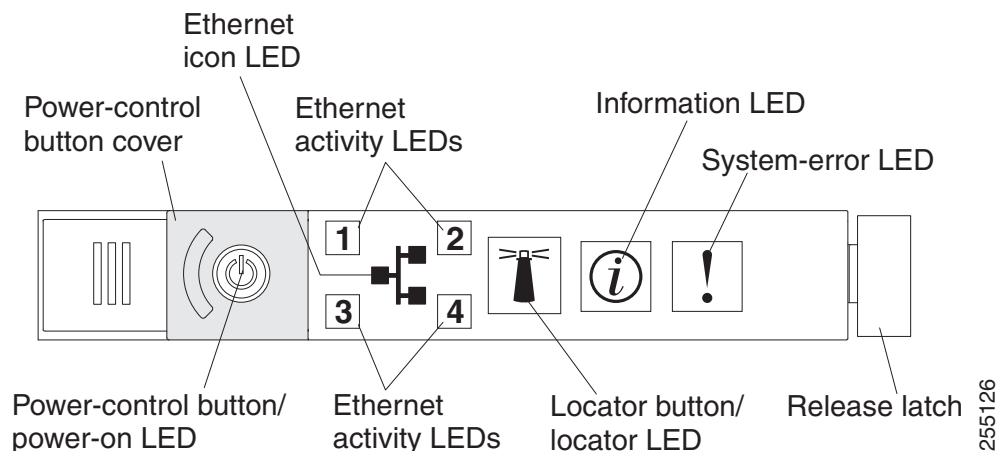

Operator Information Panel Components

- **Power-control button and power-on LED:** Press this button to turn the controller on and off manually or to wake it from a reduced-power state. The states of the power-on LED are as follows:
 - **Off:** Power is not present, or the power supply or the LED itself has failed.
 - **Flashing rapidly (4 times per second):** The controller is turned off and is not ready to be turned on. The power-control button is disabled. This will last approximately 20 to 40 seconds.
 - **Flashing slowly (once per second):** The controller is turned off and is ready to be turned on. You can press the power-control button to turn on the controller.
 - **Lit:** The controller is turned on.
 - **Fading on and off:** The controller is in a reduced-power state. To wake the controller, press the power-control button or use the IMM Web interface. See the *Integrated Management Module User's Guide* for information on logging on to the IMM Web interface.
- **Ethernet activity LEDs:** When any of these LEDs is lit, they indicate that the controller is transmitting to or receiving signals from the Ethernet LAN that is connected to the Ethernet port that corresponds to that LED.
- **System-locator button/LED:** Use this blue LED to visually locate the controller among other servers. This LED is also used as a presence detection button. This LED is controlled by the IMM. When you press the System-locator button, the LED will blink and it will continue to blink until you press it again to turn it off. The locator button is pressed to visually locate the controller among the other servers.
- **System-information LED:** When this amber LED is lit, it indicates that a noncritical event has occurred. The IMM can be used to diagnose and correct the problem.
- **System-error LED:** When this amber LED is lit, it indicates that a system error has occurred. A system-error LED is also on the rear of the controller. An LED on the light path diagnostics panel on the operator information panel is also lit to help isolate the error. This LED is controlled by the IMM.

Light Path Diagnostics Panel

The light path diagnostics panel is on the top of the operator information panel, as shown in [Figure 1-4](#). For additional information about the LEDs on the light path diagnostics panel, see [Table 1-1](#).

To access the light path diagnostics panel, slide the blue release button on the operator information panel to the left. Pull forward on the unit until the hinge of the operator panel is free of the chassis. Then pull down on the unit, so that you can view the light path diagnostics panel information.

**Note**

When you slide the light path diagnostics panel out of the controller to check the LEDs or checkpoint codes, do not run the controller continuously with the light path diagnostics panel outside of the controller. The panel should only be outside of the controller a short time. The light path diagnostics panel must remain in the controller when it is running to ensure proper cooling.

Figure 1-4 Light Path Diagnostics Panel

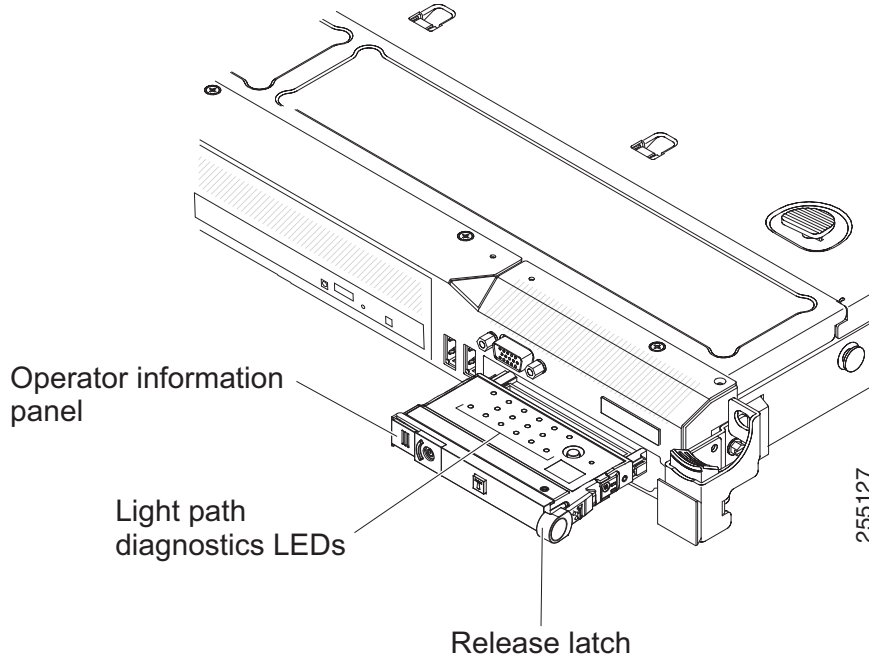
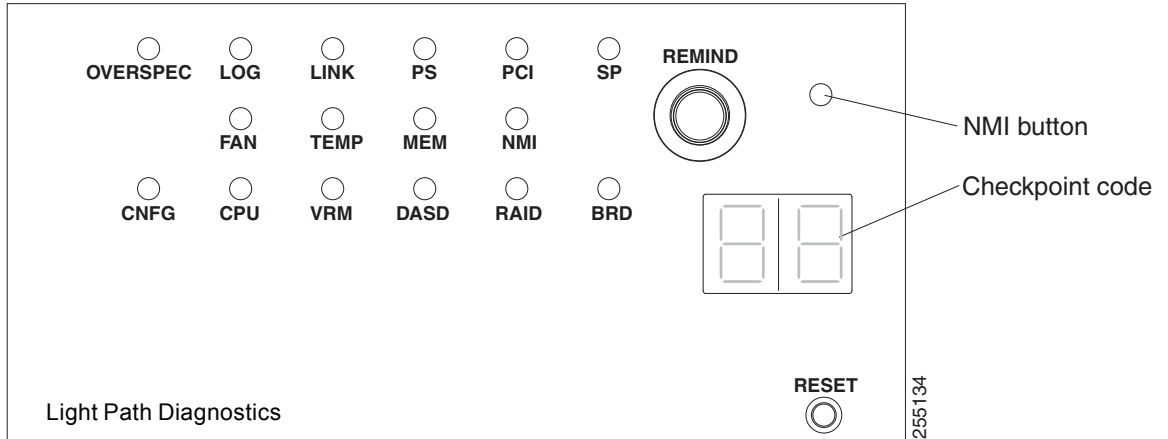

Figure 1-5 shows the LEDs and controls on the light path diagnostics panel.

Figure 1-5 Light Path Diagnostics Panel Components



Light Path Diagnostics Panel Components

- Remind button:** This button places the system-error LED on the front panel into Remind mode. In Remind mode, the system-error LED flashes once every 2 seconds until the problem is corrected, the controller is restarted, or a new problem occurs.

By placing the system-error LED indicator in Remind mode, you acknowledge that you are aware of the last failure but will not take immediate action to correct the problem. The Remind function is controlled by the IMM.

- **NMI button:** This button is used to force a nonmaskable interrupt to the microprocessor. This button is not currently used by the Cisco Flex 7500 Series Wireless Controller. Press this button only when directed by the Cisco TAC personnel.
- **Checkpoint code display:** This display provides a checkpoint code that indicates the point at which the system stopped during the boot block and POST. A checkpoint code is either a byte or a word value that is produced by UEFI. The display does not provide error codes or suggest components to be replaced.
- **Reset button:** Press this button to reset the controller and run the power-on self-test (POST). You might have to use a pen or the end of a straightened paper clip to press the button. The Reset button is in the lower-right corner of the light path diagnostics panel.

Table 1-1 Light path diagnostics panel LEDs

Follow the suggested actions in the order in which they are listed in the Action column until the problem is solved.

LED	Description	Action
None, but the system error LED is lit.	An error occurred and cannot be isolated. The error is not represented by a path.	Contact Cisco TAC for assistance.
OVER SPEC	The power supplies are using more power than their maximum rating.	Contact Cisco TAC for assistance.
LOG	An error occurred.	Check the IMM system event log and the system-error log for information about the error and then determine the next steps. If needed, contact Cisco TAC.
LINK	Reserved.	
PS	Power supply 1 or 2 has failed.	<ol style="list-style-type: none"> 1. Check the power supply that has a lit amber LED (see Power-supply LEDs, page 1-27). 2. Make sure that the power supplies are seated correctly. 3. Remove one of the power supplies to isolate the failed power supply. 4. Replace the failed power supply.
PCI	An error has occurred on a PCI bus or on the system board. An additional LED is lit next to a failing PCI slot.	Contact Cisco TAC for assistance.
SP	A service processor error has been detected.	<ol style="list-style-type: none"> 1. Shut down the system and remove the power cords from the controller; then, reconnect the controller to power and restart it. 2. If the problem does not go away, contact Cisco TAC for assistance.

Table 1-1 Light path diagnostics panel LEDs (continued)

Follow the suggested actions in the order in which they are listed in the Action column until the problem is solved.

LED	Description	Action
FAN	A fan has failed, is operating too slowly, or has been removed. The TEMP LED might also be lit.	Contact Cisco TAC to replace your Cisco Flex 7500 Series Wireless Controller and for further assistance.
TEMP	The system temperature has exceeded a threshold level. A failing fan can cause the TEMP LED to be lit.	Contact Cisco TAC for assistance.
MEM	When only the MEM LED is lit, a memory error has occurred. When both the MEM and CNFG LEDs are lit, the memory configuration is invalid or the PCI Option ROM is out of resource.	Contact Cisco TAC for assistance.
NMI	A nonmaskable interrupt has occurred, or the NMI button was pressed.	Check the system-error log for information about the error. Contact Cisco TAC if further assistance is needed.
CNFG	A hardware configuration error has occurred.	Contact Cisco TAC for assistance.
CPU	An invalid microprocessor configuration or a microprocessor has failed (both the CPU LED and the CNFG LED might be lit).	Contact Cisco TAC for assistance.
VRM	Reserved.	
DASD	A hard disk drive has failed or is missing.	<ol style="list-style-type: none"> 1. Check the LEDs on the hard disk drives for the drive with a lit status LED and reseal the hard disk drive. 2. If reseating the drive does not resolve the issue, then the failed hard disk drive must be replaced. Contact Cisco TAC for assistance.
RAID	Reserved.	
BRD	An error has occurred on the system board.	Contact Cisco TAC for assistance.

Rear Panel

Figure 1-6 shows the connectors on the rear panel for the Cisco Flex 7500 Series Wireless Controller.

Figure 1-7 shows the Cisco Flex 7500 Series Wireless Controller rear panel LEDs.

Figure 1-6 Cisco Flex 7500 Series Wireless Controller Rear Panel

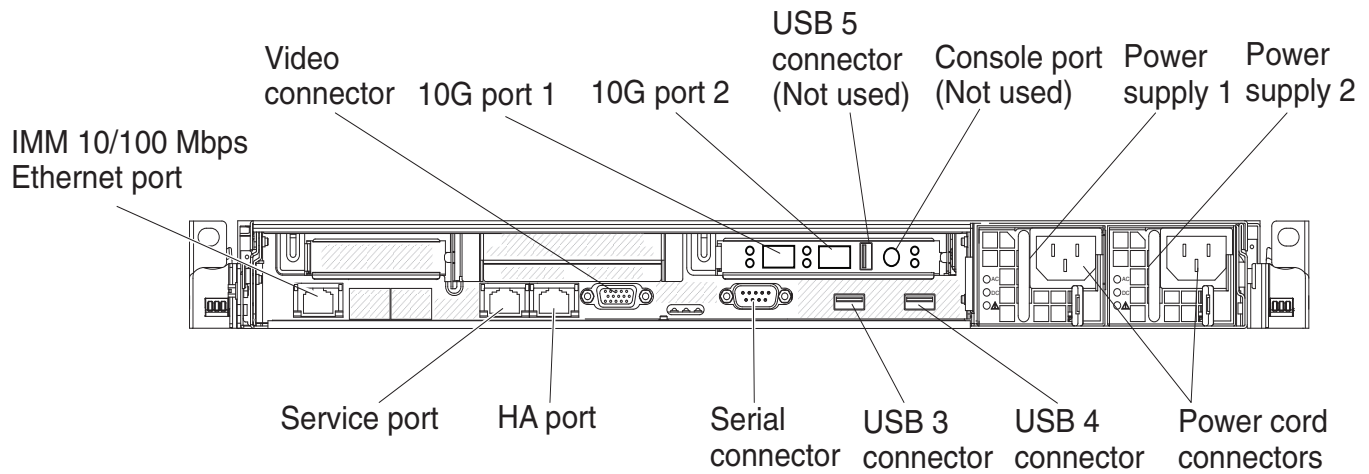

Rear Panel Components

- **10G ports:** Use these connectors to connect the controller to a network. The 10G connectors provide interface for 10 Gb SFP+ transceivers. When you use the Service Port connector, the network can be shared with the IMM through a single network cable. See additional notes about the IMM configuration and access for details.
- **Power connector:** Connect the power cord to this connector.



Note

Power supply 1 is the default/primary power supply. If power supply 1 fails, you must replace it immediately.

- **Video connector:** Connect a monitor to this connector. The video connectors on the front and rear of the controller can be used simultaneously.



Note

The maximum video resolution is 1600 x 1200 at 75 Hz.

- **Serial connector:** Connect the serial console cable to this connector.
- **USB connectors:** Connect a USB device, such as a USB mouse or keyboard to any of these connectors. During normal operation, these USB slots are not used by the Cisco Flex 7500 Series Wireless Controller.
- **Console port:** This console port is not intended for customer use. It is used by Cisco TAC for debugging purposes. Do not discard the console cable that comes with your controller.
- **IMM 10/100 Mbps Ethernet port:** Use this port to manage the controller, using a dedicated management network. If you use this connector, the IMM cannot be accessed directly from production network. A dedicated management network provides additional security by physically

separating the management network traffic from the production network. You can use the `immconfig` script provided with the controller to configure it to use a dedicated systems management network or a shared network.

Figure 1-7 shows the LEDs on the rear of the controller.

Figure 1-7 Cisco Flex 7500 Series Wireless Controller Rear Panel LEDs

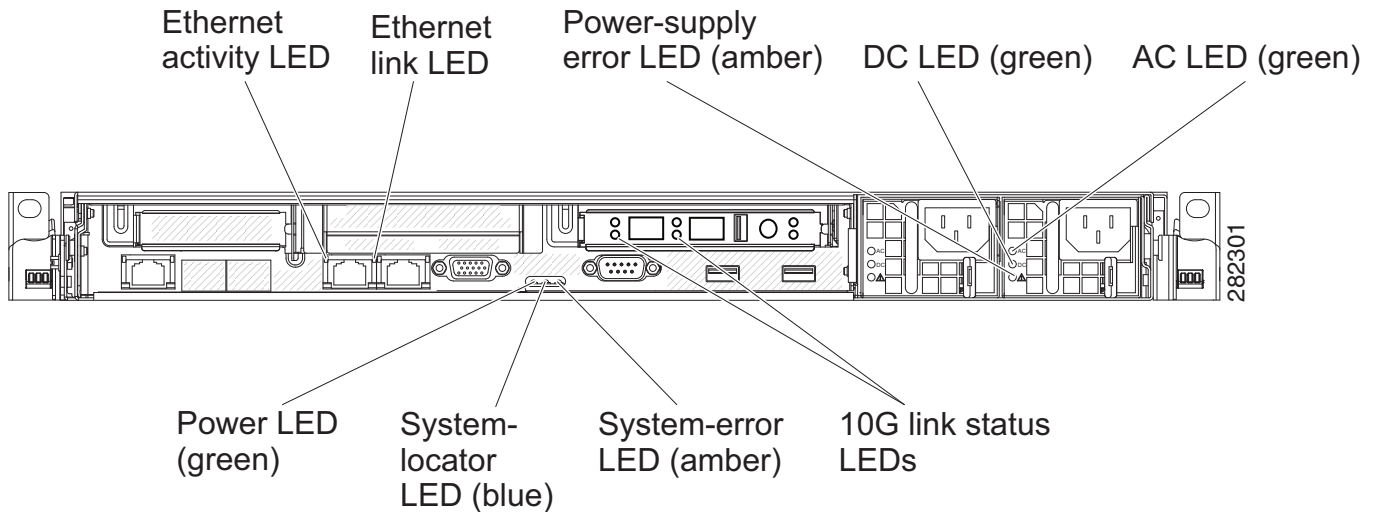
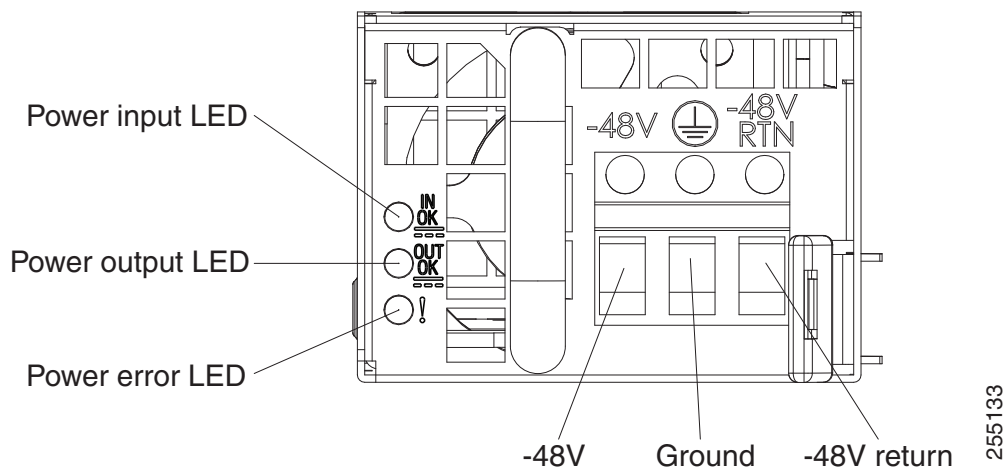

Figure 1-8 shows a detailed view of the LEDs on a dc power supply.

Figure 1-8 Close Up of Cisco Flex 7500 Series Wireless Controller DC Power Supply LEDs



- **Ethernet activity LEDs:** When these LEDs are lit, they indicate that the controller is transmitting to or receiving signals from the Ethernet LAN that is connected to the Ethernet port.
- **Ethernet link LEDs:** When these LEDs are lit, they indicate that there is an active link connection on the 10BASE-T, 100BASE-TX, or 1000BASE-TX interface for the Ethernet port.
- **AC power LED:** Each hot-swap power supply has an ac power LED and a dc power LED. When the ac power LED is lit, it indicates that sufficient power is coming into the power supply through the power cord. During typical operation, both the ac and dc power LEDs are lit.

- **IN OK power LED:** Each hot-swap dc power supply has an IN OK power LED and an OUT OK power LED. When the IN OK power LED is lit, it indicates that sufficient power is coming into the power supply through the power cord. During typical operation, both the IN OK and OUT OK power LEDs are lit.
- **DC power LED:** Each hot-swap power supply has a dc power LED and an ac power LED. When the dc power LED is lit, it indicates that the power supply is supplying adequate dc power to the system. During typical operation, both the ac and dc power LEDs are lit.
- **OUT OK power LED:** Each hot-swap dc power supply has an IN OK power LED and an OUT OK power LED. When the OUT OK power LED is lit, it indicates that the power supply is supplying adequate dc power to the system. During typical operation, both the IN OK and OUT OK power LEDs are lit.
- **10 G link status LEDs:** These LEDs individually indicate the transmit and receive activity of each 10 Gb SFP+ transceiver.
- **System-error LED:** When this LED is lit, it indicates that a system error has occurred. An LED on the light path diagnostics panel is also lit to help isolate the error.
- **Power-on LED:** When this LED is lit and not flashing, it indicates that the controller is turned on. The states of the power-on LED are as follows:
 - **Off:** Power is not present, or the power supply or the LED itself has failed.
 - **Flashing rapidly (4 times per second):** The controller is turned off and is not ready to be turned on. The power-control button is disabled. This will last approximately 20 to 40 seconds.
 - **Flashing slowly (once per second):** The controller is turned off and is ready to be turned on. You can press the power-control button to turn on the controller.
 - **Lit:** The controller is turned on.
 - **Fading on and off:** The controller is in a reduced-power state. To wake the controller, press the power-control button or use the IMM Web interface. See the *Integrated Management Module User's Guide* for information on logging on to the IMM Web interface.
- **System-locator LED:** Use this LED to visually locate the controller among other servers. You can use the *Integrated Management Module User's Guide* to light this LED remotely.

Power-supply LEDs

Figure 1-9 shows the location of the power-supply LEDs on the rear of the Cisco Flex 7500 Series Wireless Controller. See Table 1-2 for additional information about solving power-supply problems.

Figure 1-9 Location of the Cisco Flex 7500 Series Wireless Controller Power Supply LEDs

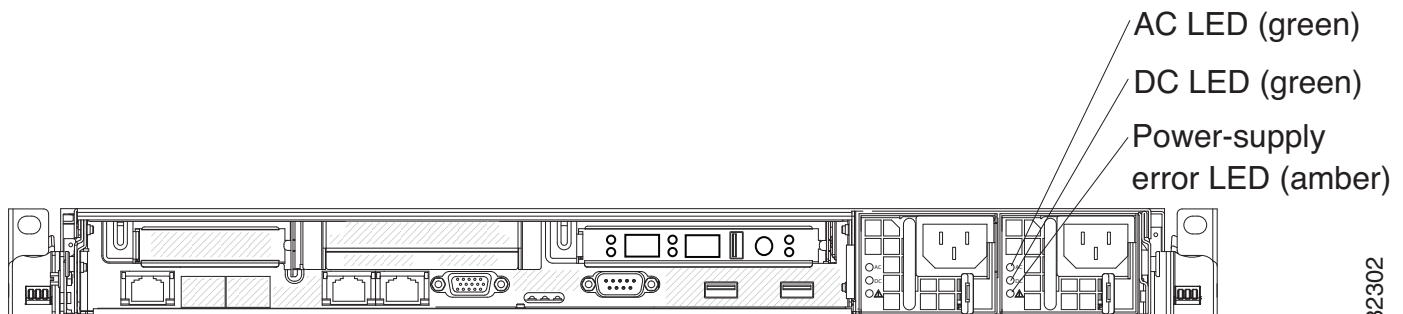

282302

Table 1-2 describes the problems that are indicated by various combinations of the power-supply LEDs on an ac power supply and suggested actions to correct the detected problems.

Table 1-2 Cisco Flex 7500 Series Wireless Controller AC Power Supply Troubleshooting

AC power-supply LEDs			Description	Action	Notes
AC	DC	Error (!)			
On	On	Off	Normal operation		
Off	Off	Off	No AC power to the controller or a problem with the AC power source.	<ol style="list-style-type: none"> 1. Check the AP power to the controller. 2. Make sure that the power cord is connected to a functioning power source. 3. Restart the controller. If the error remains, check the power supply LEDs. 4. Replace the power supply. 	This is a normal condition when no AC power is present.
Off	Off	On	No AC power to the controller or a problem with the AC power source and the power supply had detected an internal problem.	<ol style="list-style-type: none"> 1. Make sure that the power cord is connected to a functioning power source. 2. Replace the power supply. 	This happens only when a second power supply is providing power to the controller.
Off	On	Off	Faulty power supply	Replace the power supply.	
Off	On	On	Faulty power supply	Replace the power supply.	
On	Off	Off	Power supply not fully seated, faulty system board, or faulty power supply	<ol style="list-style-type: none"> 1. Reseat the power supply. 2. If this action does not resolve the problem, replace the power supply. If replacing the power supply does not resolve the issue, contact Cisco TAC for assistance. 	Typically indicates a power supply is not fully seated.
On	Off	On	Faulty power supply	Replace the power supply.	
On	On	On	Power supply is faulty but still operational	Replace the power supply.	

Cisco Flex 7500 Series Wireless Controller Power Features

Specific steps to power-on the Cisco Flex 7500 Series Wireless Controller are provided in [Powering On the Controller](#), page 1-33.

When the controller is connected to an ac power source but is not turned on, the operating system does not run, and all core logic except for the service processor (the Integrated Management Module) is shut down; however, the controller can respond to requests to the service processor, such as a remote request to turn on the controller. The power-on LED flashes to indicate that the controller is connected to power but is not turned on.

Turning on the Cisco Flex 7500 Series Wireless Controller

Approximately 5 seconds after the controller is connected to power, one or more fans might start running to provide cooling while the system is connected to power, and the power-on button LED will blink quickly. Approximately 20 to 40 seconds after the controller is connected to power, the power-control button becomes active (the power-on LED will blink slowly), and one or more fans might start running to provide cooling while the controller is connected to power. You can turn on the controller by pressing the power-control button.

If a power failure occurs while the controller is turned on, the system will restart automatically when power is restored.

Turning off the Cisco Flex 7500 Series Wireless Controller

When you turn off the controller and leave it connected to power, it can respond to requests to the service processor, such as a remote request to turn on the controller. While the controller remains connected to power, one or more fans might continue to run. To remove all power from the controller, you must disconnect it from the power source.



Caution

The power control button on the device and the power switch on the power supply do not turn off the electrical current supplied to the device. The device also might have more than one power cord. To remove all electrical current from the device, ensure that all power cords are disconnected from the power source.

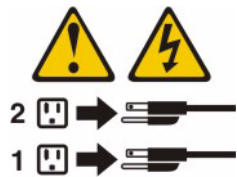

The integrated management module (IMM) can turn off the controller as an automatic response to a critical system failure.

Grounding the Chassis



Caution

All power supplies must be grounded. The receptacles of the AC power cables used to provide power to the chassis must be the grounding type, and the grounding conductors should connect to protective earth ground at the service equipment.

Preventing ESD Damage

Electrostatic discharge (ESD) damage occurs when electronic cards or components are improperly handled and can result in complete or intermittent failures.

Always use an ESD-preventive wrist or ankle strap and ensure that it makes good skin contact. Connect the strap to any unpainted surface on the chassis



Caution

Periodically check the resistance value of the antistatic strap. The measurement should be between 1 and 10 megohms (Mohms).

Replacing a Failed Hot-Swap Hard Disk Drive

To replace a 2.5-inch hot-swap SAS hard disk drive, complete the following steps.

You can order replacement hard disk drives from Cisco. The replacement part PID is AIR-SRVR-146GB-HD=.

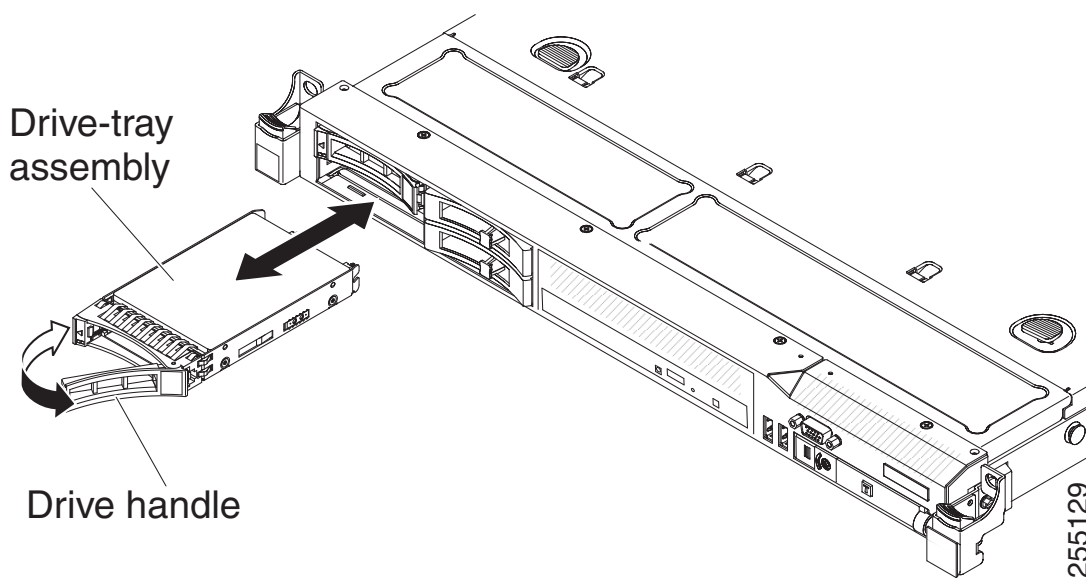

- Step 1** Read the safety information in [General Warnings, Regulatory and Safety, page 1-5](#).
- Step 2** Touch the static-protective package that contains the drive to any unpainted metal surface on the controller; then, remove the drive from the package and place it on a static-protective surface.
- Step 3** Ensure that the drive you are replacing has failed before pulling it out of the drive slot. Press on the tray handle to unlock the drive. Pull on the tray handle to remove the drive.
- Step 4** Install the hard disk drive in the drive bay:
 - a. Make sure that the tray handle is in the open (unlocked) position.
 - b. Align the drive assembly with the guide rails in the bay.
 - c. Gently push the drive assembly into the bay until the drive stops.
 - d. Rotate the tray handle to the closed (locked) position.

- e. Check the hard disk drive status LED to verify that the hard disk drive is operating correctly. If the amber hard disk drive status LED for a drive is lit continuously, that drive is faulty and must be replaced. If the green hard disk drive activity LED is flashing, the drive is being accessed.

Replacing a Hot-Swap AC Power Supply

The following section describes the type of ac power supply that the server supports and other information that you must consider when you replace a failed power supply:

- The Cisco Flex 7500 Series Wireless Controller comes with two 675-watt hot-swap 12-volt output power supplies that connect to power supply bays 1 and 2. The input voltage is 110 V ac or 220 V ac auto-sensing.
- Power supply 1 is the default/primary power supply. If power supply 1 fails, you must replace the power supply immediately.
- You can order replacement power supplies from Cisco. The replacement part PID is AIR-SRVR-PWR=.
- These power supplies are designed for parallel operation. In the event of a power-supply failure, the redundant power supply continues to power the system.



Caution

The power control button on the device and the power switch on the power supply do not turn off the electrical current supplied to the device. The device also might have more than one power cord. To remove all electrical current from the device, ensure that all power cords are disconnected from the power source.

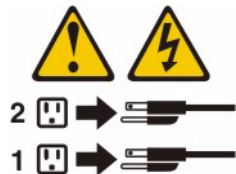

Caution

Never remove the cover on a power supply or any part that has the following label attached. Hazardous voltage, current, and energy levels are present inside any component that has this label attached. There are no serviceable parts inside these components. If you suspect a problem with one of these parts, contact a service technician.



To install a hot-swap power supply, complete the following steps.

-
- Step 1** Read the safety information in [General Warnings, Regulatory and Safety, page 1-3](#).
 - Step 2** Touch the static-protective package that contains the hot-swap power supply to any unpainted metal surface on the controller; then, remove the power supply from the package and place it on a static-protective surface.
 - Step 3** Remove the failed power supply first. Grasp the handle on the rear of the power supply and slide the power supply out from the chassis.

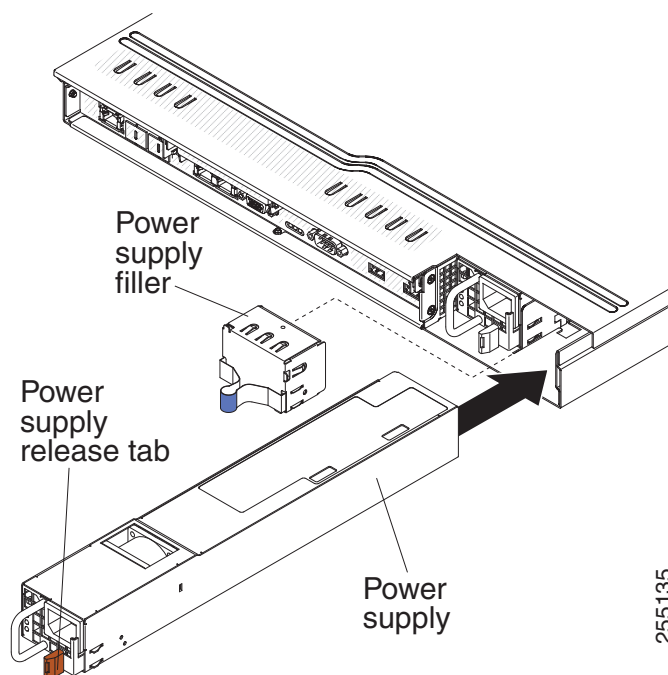

- Step 4** Grasp the handle on the rear of the power supply and slide the power supply forward into the power-supply bay until it clicks. Make sure that the power supply connects firmly into the power-supply connector.
 - Step 5** Route the power cord through the handle so that it does not accidentally become unplugged.
 - Step 6** Connect the power cord for the new power supply to the power-cord connector on the power supply.
 - Step 7** Connect the other end of the power cord to a properly grounded electrical outlet.
 - Step 8** Make sure that the ac power LED and the dc power LED on the ac power supply are lit, indicating that the power supply is operating correctly. The two green LEDs are to the right of the power-cord connector.
-

Connecting the Cables

Figure 1-10 shows the locations of the input and output connectors on the front of the server.

Figure 1-10 Front of Cisco Flex 7500 Series Wireless Controller

Figure 1-11 shows the locations of the input and output connectors on the rear of the server.

Figure 1-11 Rear of Cisco Flex 7500 Series Wireless Controller

Connecting and Using the CLI Console

For initial system configuration, use the command-line interface (CLI) console. The CLI console connects to the controller back-panel DB9 console port. [Figure 1-6 on page 1-25](#) shows the console port on the back panel of the controller. Back panel components are described in [Rear Panel Components, page 1-25](#).

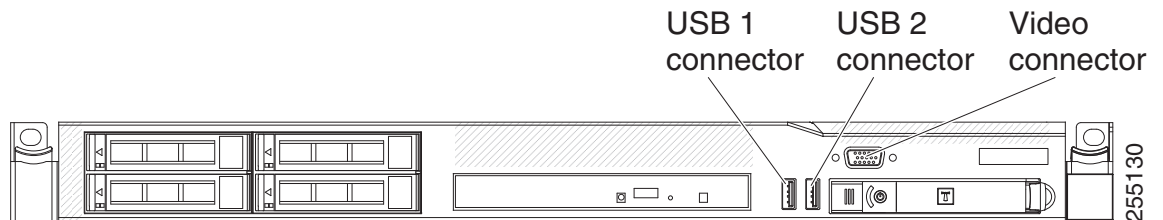
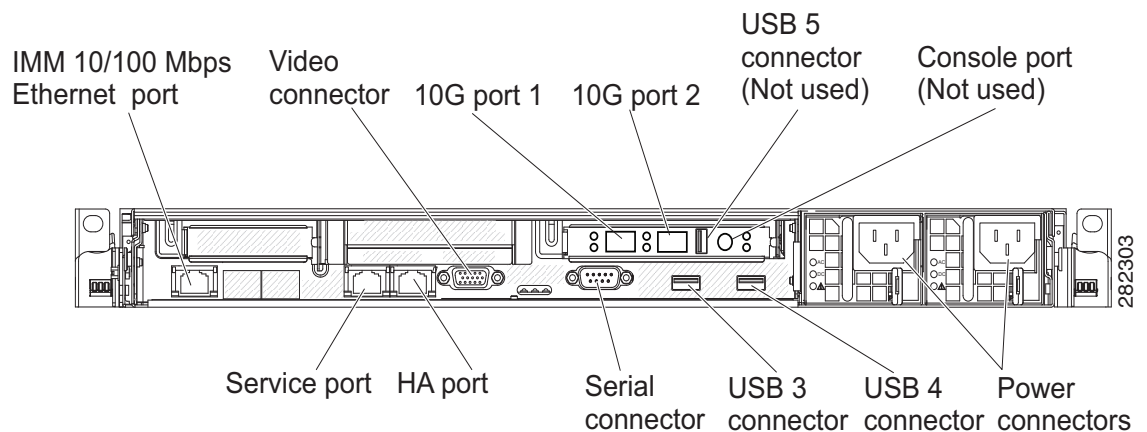
Use these terminal emulator settings for the CLI console session:

- 9600 baud
- 8 data bits
- no flow control
- 1 stop bit
- no parity

Powering On the Controller

When you apply AC power to a controller, the bootup script initializes the operating system and its stored configurations. You are prompted to enter a user ID and password and enter key configuration details.

Follow these steps to power up the controller.

-
- Step 1** Plug an AC power cord into the back of the two power supplies (Figure 1-6 on page 1-25). If only one power supply is connected to a power source, the system will still function correctly but the monitoring components of the controller will detect the absence of the second power supply and will raise an alarm. Connect the other end of the power cord to a properly grounded 100 to 240 VAC 50/60 Hz electrical outlet.
- The end of the power cord that plugs into the controller conforms with the IEC 320 standard.
- Step 2** Use the front-panel Power On/Standby button, located in the operator information panel, to turn the controller on (Figure 1-3 on page 1-20).
- Step 3** At the login prompt, enter the controller operating user ID and password. The default user ID is *root* and the default password is *password*.
- The user ID and password are case sensitive.
- You are now logged into the controller operating system.
- Continue to the “Running the Bootup Script and Power-On Self Test” section on page 1-34.
-

Running the Bootup Script and Power-On Self Test

When you plug the controller into an AC power source, the bootup script initializes the system, verifies the hardware configuration, loads its microcode into memory, verifies its operating system software load, and initializes itself with its stored configurations. Before performing this test, you should connect your terminal emulator application to the controller’s CLI console as described in the “Connecting and Using the CLI Console” section on page 1-33. Follow these steps to run the bootup script and conduct the power-on self test (POST).

-
- Step 1** Plug an AC power cord into the back of the controller and connect the other end to a grounded 100 to 240 VAC, 50/60 Hz electrical outlet. Be sure to connect both power supplies to a power source.
- Step 2** Turn on the power supply.
- Step 3** Observe the bootup on the CLI screen.

The bootup script displays operating system software initialization (code download and POST verification) and basic configuration as shown in the following sample bootup display:

```

LSI MegaRAID SAS-MFI BIOS                               Version 4.19.00 (Build October 19, 2010)
Copyright (c) 2010 LSI Corporation
HA -0 (Bus 1 Dev 0) ServeRAID M1015 SAS/SATA Controller
0JBOD(s) found on the host adapter                      0JBOD(s) handled by BIOS
1 Virtual Drive(s) found on the host adapter.
1 Virtual Drive(s) handled by BIOS
  Cisco Bootloader (Version 7.0.110.30)

      .o88b. d8888888b .d8888. .o88b. .d88b.
d8P Y8 `88' 88' YP d8P Y8 .8P Y8.
8P      88 `8bo. 8P      88 88
8b      88 `Y8b. 8b      88 88
Y8b d8 .88. db 8D Y8b d8 `8b d8'
`Y88P' Y888888P `8888Y' `Y88P' `Y88P'

Booting Primary Image...
Press <ESC> now to access the Boot Menu...

```

Step 4 If desired, press **Esc** to display the Bootloader Boot Options menu.

```
Boot Options
```

```
Please choose an option from below:
```

1. Run primary image
2. Run backup image
3. Manually update images
4. Change active boot image
5. Clear Configuration

```
Please enter your choice:
```



Note Enter **1** to run the current software, enter **2** to run the previous software, or enter **4** to run the current software and set the controller configuration to factory defaults. Do not choose the other options unless directed to do so.

Step 5 The rest of the process takes two to three minutes. Do not reboot the controller until the user login prompt appears.

```
Booting 'Primary image'
```

```

Detecting Hardware . . .3
INIT: version 2.86 booting
Starting the hotplug events dispatcher: udevd.
Synthesizing the initial hotplug events...done.
Waiting for /dev to be fully populated...done.
Activating swap...done.
Remounting root filesystem...done.
Mounting local filesystems: mount none on /var/run type tmpfs (rw)
none on /tmp type tmpfs (rw)
Setting up networking ....
Starting hotplug subsystem:
  pci
  pci      [success]
  usb
  usb      [success]
  isapnp
  isapnp   [success]
  ide
  ide      [success]
  input
  input    [success]
  scsi
  scsi     [success]
done.
Starting portmap daemon...
Octeon Found...
Detecting Hardware ...
Booting Octeon...
Using user supplied board name: nic_xle_10g
All cores in reset, skipping soft reset.
Using bootloader image: /octeon/u-boot-octeon_nic_xle_10g_pciboot.bin
Initialized 2048 MBytes of DRAM
INIT: Entering runlevel: 3

Cryptographic library self-test....passed!
XML config selected
Validating XML configuration
octeon_device_init: found 1 DPs

```

```
Cisco is a trademark of Cisco Systems, Inc.
Software Copyright Cisco Systems, Inc. All rights reserved.
```

```
Cisco AireOS Version 7.0.114.110
```

```
. . .
```

```
Starting Management Services:
```

```
Web Server: ok
CLI: ok
Secure Web: ok
License Agent: ok
```

```
(Cisco Controller)
```

```
Enter User Name (or 'Recover-Config' this one-time only to reset configuration to factory
defaults)
```

```
User: admin
Password: *****
(Cisco Controller)
```

- Step 6** If the controller passes the power-on self test, the bootup script runs the Startup Wizard, which prompts you for basic configuration input.



Note Cisco Flex 7500 Series Wireless Controller version V02 cannot run on AireOS prior to Release 7.0.240.0, 7.2.115.0, or 7.3.101.0.

Using the Startup Wizard

Before you can use the startup wizard, you must obtain the information discussed in the [“Required Tools and Information”](#) section on page 1-6.



Note

The available options appear in brackets after each configuration parameter. The default value appears in all uppercase letters.



Note

Press the hyphen key if you need to return to the previous command line.

To configure the controller for basic operation using the Startup Wizard, follow these steps:

- Step 1** When prompted to terminate the AutoInstall process, enter **yes**. If you do not enter **yes**, the AutoInstall process begins after 30 seconds.

```
Welcome to the Cisco Wizard Configuration Tool
Use the '-' character to backup
```

```
Would you like to terminate autoinstall? [yes]:
AUTO-INSTALL: starting now...
rc = 0
```



Note The AutoInstall feature downloads a configuration file from a TFTP server and then loads the configuration onto the controller automatically.

- Step 2** Enter the system name, which is the name you want to assign to the controller. You can enter up to 31 ASCII characters.

```
System Name [Cisco_d9:3d:66] (31 characters max):
AUTO-INSTALL: no interfaces registered.
```

```
AUTO-INSTALL: process terminated -- no configuration loaded
```

- Step 3** Enter the administrative username and password to be assigned to this controller. You can enter up to 24 ASCII characters for each.

```
Enter Administrative User Name (24 characters max): admin
Enter Administrative Password (3 to 24 characters): *****
Re-enter Administrative Password                : *****
```

- Step 4** If you want the controller's service-port interface to obtain an IP address from a DHCP server, enter **DHCP**. If you do not want to use the service port or if you want to assign a static IP address to the service-port interface, enter **static**.

```
Service Interface IP Address Configuration [static][DHCP]: static
```



Note The *service-port interface* controls communications through the service port. Its IP address must be on a different subnet from the management interface. This configuration enables you to manage the controller directly or through a dedicated management network to ensure service access during network downtime.

The service port works with auto-negotiation and in full duplex mode only. The other device such as switch and access point that communicates with the controller must be set to full duplex and auto-negotiation mode.

You can use the command **show interface detailed service-port** to check all the service port interface parameters on the controller.

- Step 5** If you entered **static** in [Step 4](#), enter the IP address and netmask for the service-port interface on the next two lines.

```
Service Interface IP Address: 172.19.30.18
Service Interface Netmask: 255.255.254.0
```

- Step 6** Enter the IP address, netmask, default router IP address, optional VLAN identifier (a valid VLAN identifier or 0 for an untagged VLAN), and the port number for the management interface.



Note The VLAN identifier should be set to match the switch interface configuration.

```
Management Interface IP Address: 192.168.1.10
Management Interface Netmask: 255.255.0.0
Management Interface Default Router: 192.168.1.1
Management Interface VLAN Identifier (0 = untagged): 192
Management Interface Port Num [1 to 2]: 1
```

- Step 7** Enter the IP address of the default DHCP server that will supply IP addresses to clients, the controller's management interface.

Management Interface DHCP Server IP Address: 192.168.1.1



Note The *management interface* is the default interface for in-band management of the controller and connectivity to enterprise such as AAA servers.

- Step 8** Enter the IP address of the controller's virtual interface, which will be used by all controller Layer 3 security and mobility managers. You should enter a fictitious, unassigned IP address, such as 192.0.2.1.

Virtual Gateway IP Address: 192.0.2.1



Note The *virtual interface* is used to support mobility management, DHCP relay, and embedded Layer 3 security such as guest web authentication and VPN termination. All controllers within a mobility group must be configured with the same virtual interface IP address.

- Step 9** If desired, enter the name of the mobility group/RF group to which you want the controller to belong.

Mobility/RF Group Name: amb



Note Although the name that you enter here is assigned to both the mobility group and the RF group, these groups are not identical. Both groups define clusters of controllers, but they have different purposes. All of the controllers in an RF group are usually also in the same mobility group and vice versa. However, a *mobility group* facilitates scalable, system-wide mobility and controller redundancy while an *RF group* facilitates scalable, system-wide dynamic RF management.

- Step 10** Enter the network name, or *service set identifier (SSID)*. The initial SSID enables basic functionality of the controller and allows access points that have joined the controller to enable their radios.

Network Name (SSID): amb

- Step 11** Enter **yes** to enable DHCP proxy or **no** to disable DHCP proxy.

Configure DHCP Bridging Mode [yes][NO]:yes

- Step 12** Enter **yes** to allow clients to assign their own IP address or **no** to make clients request an IP address from a DHCP server.

Allow Static IP Addresses [YES][no]:

- Step 13** To configure a RADIUS server now, enter **yes** and then enter the IP address, communication port, and secret key of the RADIUS server. Otherwise, enter **no**.

Configure a RADIUS Server now? [YES][no]: no

Warning! The default WLAN security policy requires a RADIUS server.
Please see documentation for more details.

- Step 14** Enter the code for the country in which the controller will be used.

Enter Country Code list (enter 'help' for a list of countries) [US]:



Note Enter **help** to view the list of available country codes.

- Step 15** Enter **yes** to enable or **no** to disable each of the 802.11b, 802.11a, and 802.11g lightweight access point networks.

```
Enable 802.11b Network [YES][no]:
Enable 802.11a Network [YES][no]:
Enable 802.11g Network [YES][no]:
```



Note 802.11n is always enabled.

- Step 16** Enter **yes** to enable or **no** to disable the controller's radio resource management (RRM) auto RF feature.

```
Enable Auto-RF [YES][no]:
```



Note The *auto RF* feature enables the controller to automatically form an RF group with other controllers. The group dynamically elects a leader to optimize RRM parameter settings, such as channel and transmit power assignment, for the group.

- Step 17** If you want the controller to receive its time setting from an external Network Time Protocol (NTP) server when it powers up, enter **yes** to configure an NTP server. Otherwise, enter **no**.

```
Configure a NTP server now? [YES][no]: no
```

- Step 18** If you entered **no** in the previous step and want to manually configure the system time on your controller now, enter **yes**. If you do not want to configure the system time now, enter **no**.

```
Configure the system time now? [YES][no]:
```

- Step 19** If you entered **yes** in the previous step, enter the current date in MM/DD/YY format and the current time in HH:MM:SS format.

```
Enter the date in MM/DD/YY format: 03/28/11
Enter the time in HH:MM:SS format: 14:36:30
```

- Step 20** When prompted to verify that the configuration is correct, enter **yes** or **no**.

```
Configuration correct? If yes, system will save it and reset. [yes][NO]: yes
```

The controller saves your configuration, reboots, and prompts you to log in.

```
Configuration saved!
Resetting system with new configuration...

Configuration saved!
Resetting system with new configuration...
SoftDog: Unexpected close, not stopping watchdog!
INIT: Switching to runlevel: 6
INIT: Sending processes the TERM signal
Stopping portmap daemon...
Sending all processes the TERM signal... done.
```

Logging into the Controller

Follow these steps to log into the controller.

Step 1 Enter a valid username and password to log into the controller CLI.



Note The administrative username and password you created in the Startup Wizard are case sensitive.

Step 2 The CLI displays the root level system prompt:

```
#(system prompt)>
```

The system prompt can be any alphanumeric string up to 31 characters. You can change it by entering the **config prompt** command.



Note The CLI automatically logs you out without saving any changes after 5 minutes of inactivity. You can set the automatic logout from 0 (never log out) to 160 minutes using the **config serial timeout** command.



Note Cisco Aironet lightweight access points do not connect to the Cisco Flex 7500 Series Wireless Controller if the date and time are not set properly. Set the current date and time on the controller before allowing the access points to connect to it.

Verifying Interface Settings and Port Operation

Follow these steps to verify that your interface configurations have been set properly and the controller's ports are operational.

Step 1 Enter **show interface summary**. The controller's current interface configurations appear:

Interface Name	Port	Vlan Id	IP Address	Type	Ap Mgr	Guest
management	1	192	192.168.1.10	Static	Yes	No
service-port	N/A	N/A	172.19.30.18	Static	No	No
virtual	N/A	N/A	192.0.2.1	Static	No	No

Step 2 Enter **show port summary**. The following information appears, showing the status of the controller's distribution system ports, which serve as the data path between the controller and Cisco lightweight access points and to which the controller's management interface is mapped.

Pr	Type	STP Stat	Admin Mode	Physical Mode	Physical Status	Link Status	Link Trap	POE
1	Normal	Forw	Enable	Auto	10000 Full	Up	Enable	N/A
2	Normal	Forw	Enable	Auto	10000 Full	Up	Enable	N/A

A link status of *Up* indicates that the controller's ports are fully operational.

Connecting the Network (Distribution System)

The SFP+ module supported by the Cisco Flex 7500 Series Wireless Controller is the Cisco SFP-10G-SR.

Cisco SFP-10G-SR: The Cisco 10GBASE-SR Module supports a link length of 26m on standard Fiber Distributed Data Interface (FDDI)-grade multimode fiber (MMF). Using 2000 MHz*km MMF(OM3), up to 300m link lengths are possible.

Depending on the distribution system physical port to be assigned, use only standard compliant fiber-optic cables to connect the network equipment to the controller

**Note**

Only connections with patch cords with PC or UPC connectors are supported. Patch cords with APC connectors are not supported. All cables and cable assemblies used must be compliant with the standards specified in the standards section.

Connecting the Controller's Service Port (Optional)

The service port is controlled by the service-port interface and is reserved for out-of-band management of the controller and system recovery and maintenance in the event of a network failure. The service-port interface enables the controller to be managed on an interface different from the one used for your network traffic. Use of the service port is optional.

You can perform out-of-band controller management from a PC running a terminal emulation program or a PC running Cisco WCS, a network management tool that enables you to configure and monitor a network of controllers, or the controller GUI. However, you must first connect the PC to the controller's service port in one of two ways:

- Use an Ethernet cross-over cable to connect the PC directly to the controller's service port.
- For a remote connection (using Telnet or SSH) through a dedicated management network, use a Category 5, Category 5e, Category 6, or Category 7 Ethernet cable to connect the management network to the controller's service port and the appropriate cable to connect the PC to the management network.

Connecting Access Points

After you have configured the controller, use Category-5, Category-5e, Category-6, or Category-7 Ethernet cables to connect Cisco lightweight access points to the network.

As soon as the controller is operational, it starts to scan for access points. When it detects an access point, it records the access-point MAC address in its database. The controller radio resource management (RRM) feature then automatically configures the access point to start sending and allowing clients to associate.

You have prepared the controller for basic operation. Refer to the *Cisco Wireless LAN Controller Configuration Guide, Release 7.0*, for information on configuring the controller to meet the specific needs of your wireless network.

**Note**

The Cisco Flex 7500 Series Wireless Controller only supports Cisco H-REAP access points and Cisco Aironet access points operating in monitor mode. No other Cisco access points are supported by the Cisco Flex 7500 Series Wireless Controller.

Controller Specifications

Chassis Dimensions	Width = 17.3 in (44.0 cm) Depth = 21.20 in (53.9 cm) Height = 1.75 in (4.45 cm)
Weight	20 lbs (9.1 kg) with two power supplies installed
Temperature range	Operating: 50 to 95°F (10 to 35°C) Storage: -40 to 140°F (-40 to 60°C)
Humidity	Operating humidity: 20 - 80%, non-condensing Storage humidity: up to 95%

Obtaining Documentation and Submitting a Service Request

For information on obtaining documentation, submitting a service request, and gathering additional information, see the monthly *What's New in Cisco Product Documentation*, which also lists all new and revised Cisco technical documentation, at:

<http://www.cisco.com/c/en/us/td/docs/general/whatsnew/whatsnew.html>

Subscribe to the *What's New in Cisco Product Documentation* as an RSS feed and set content to be delivered directly to your desktop using a reader application. The RSS feeds are a free service. Cisco currently supports RSS Version 2.0.

Cisco 90-Day Limited Hardware Warranty Terms

There are special terms applicable to your hardware warranty and various that you can use during the warranty period. Your formal Warranty Statement, including the warranties and license agreements applicable to Cisco software, is available on Cisco.com. Follow these steps to access and download the *Cisco Information Packet* and your warranty and license agreements from Cisco.com.

1. Launch your browser, and go to this URL:

<http://www.cisco.com/c/en/us/products/warranty-listing.html>

The Warranties and License Agreements page appears.

2. To read the *Cisco Information Packet*, follow these steps:

- a. Click the **Information Packet Number** field, and make sure that the part number 78-5235-03B0 is highlighted.
- b. Select the language in which you would like to read the document.
- c. Click **Go**.

The Cisco Limited Warranty and Software License page from the Information Packet appears.

- d. Read the document online, or click the **PDF** icon to download and print the document in Adobe Portable Document Format (PDF).



Note You must have Adobe Acrobat Reader to view and print PDF files. You can download the reader from Adobe's website.

3. To read translated and localized warranty information about your product, follow these steps:
 - a. Enter this part number in the Warranty Document Number field:
78-5236-01C0
 - b. Select the language in which you would like to read the document.
 - c. Click **Go**.
The Cisco warranty page appears.
 - d. Review the document online, or click the **PDF** icon to download and print the document in Adobe Portable Document Format (PDF).

Click this link to browse to the Cisco Support and Documentation page:

<http://www.cisco.com/c/en/us/support/index.html>

Duration of Hardware Warranty

Ninety (90) days.

Replacement, Repair, or Refund Policy for Hardware

Cisco or its service center will use commercially reasonable efforts to ship a replacement part within ten (10) working days after receipt of a Return Materials Authorization (RMA) request. Actual delivery times can vary, depending on the customer location.

Cisco reserves the right to refund the purchase price as its exclusive warranty remedy.

To Receive a Return Materials Authorization (RMA) Number

Contact the company from whom you purchased the product. If you purchased the product directly from Cisco, contact your Cisco Sales and Service Representative.

Complete the information below, and keep it for reference:

Company product purchased from	
Company telephone number	
Product model number	
Product serial number	
Maintenance contract number	

